

52.260

ViewMate Ecoline Monitor Arm 260

This version combines strength, practicality and usability in one package. Allowing users to adjust the height of their dual monitor setup with the greatest of ease, due to the 'Quick Adjust' lever. With integrated cable management at the back of the wing as well as on the pole, this product offers a practical and user friendly way to achieve a good and affordable dual monitor set-up.

- Mounts two (wide) screens horizontally up to 24"
- Height adjustable
- VESA: MIS-D 75 x 75/100 x 100mm compatible
- Rotate 360°, tilt 180°, lateral +90°/-90°
- Max. weight capacity of 15kg/monitor
- Post height 400mm
- Post diameter 38mm
- Quick lock/release post bracket
- With integrated desk clamp
- Max. clamp capacity 60mm



 viewmate

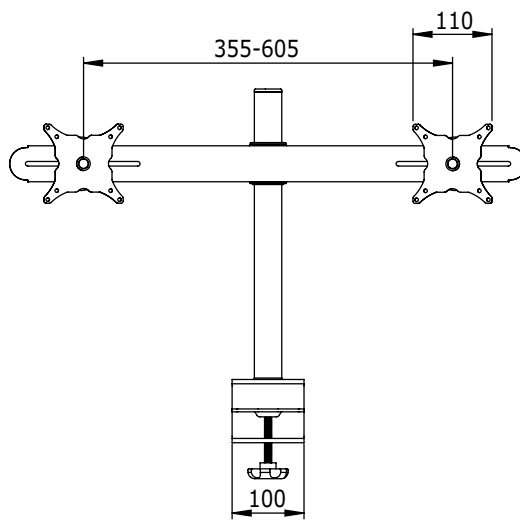
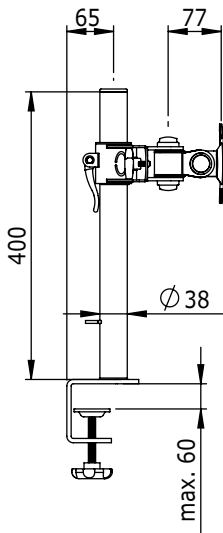
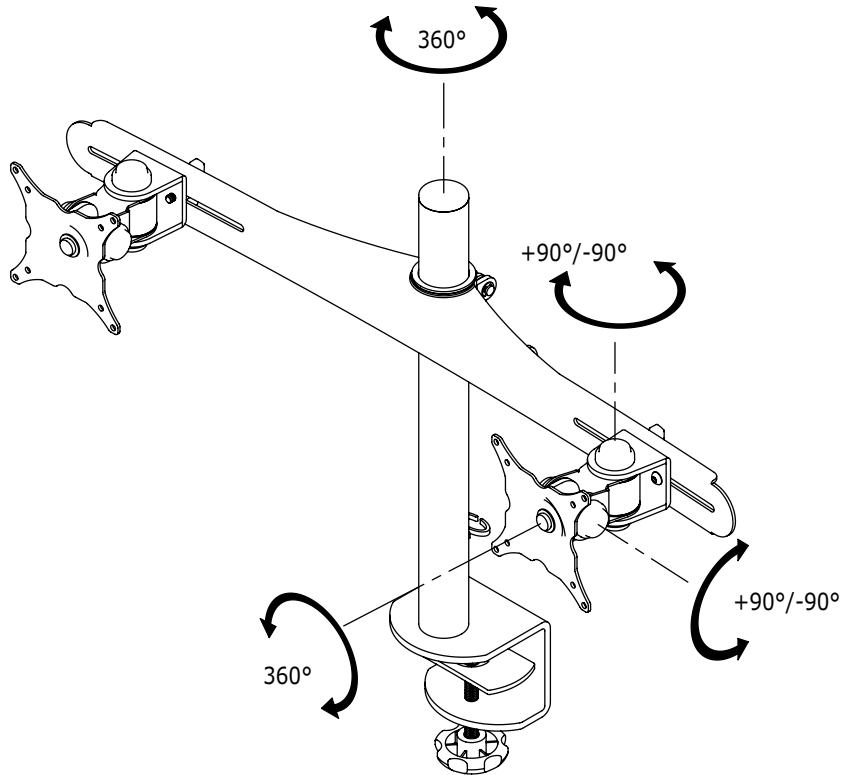

DFX.# 52.260

white

780 x 200 x 140mm

5,4kg

805410522605



24"W/61cm



(2x) 15kg



400mm



+90°/-90°



180°



360°



75/100mm

Dealer