



Create long-lasting outdoor signage with the fastest printer in its class.<sup>1</sup> This 1626 mm HP Designjet is an excellent tool to boost production and profitability: increase your print volume, improve your services, and reduce your costs.



## Move your productivity to the next level

- **Heavy-duty HP printheads and HP supplies for maximum productivity.** Experience high-speed printing with six heavy-duty Piezo printheads that come with 512 nozzles per printhead for a total of 3,072 nozzles. 1000 ml, HP 790 ink cartridges are designed to meet your usage needs.
- **Enable long, unattended print runs for improved productivity with the HP Take-Up Reel.** Busy print and sign shop employees can be more productive by maximizing unattended printing with four winding modes: slack/face-in, slack/face-out, tight/face-in, and tight/face-out.
- **HP Smart printing technology<sup>2</sup> makes HP "low-solvent"<sup>3</sup> printing supplies easy to use and manage.** Interactive system technology in HP ink cartridges, printheads, and your printer optimizes print quality and reliability and monitors ink levels.
- **Dry signs quickly and safely with the easy-to-operate HP Designjet High Speed Dryer.** Add this optional high-speed dryer and accelerate drying time. Control temperature, fan airflow, and the timer from the front panel. Combine the dryer with the automatic Take-Up Reel Kit and enable long, unattended print runs at maximum print speeds.

## Vivid colors with excellent durability

- **Wow your clients with vivid color output that shines brightly.** Create signs, banners, and large graphics with such vivid color, they radiate success. Sophisticated HP low-solvent ink formulations and printhead technology enable a higher concentration of colorants in the inks to produce a wider gamut of rich, saturated color. The result - more vivid color for high impact image quality.
- **HP low-solvent inks - excellent durability without lamination on low-cost, uncoated media.** Designed with the HP 9000s Printer, HP low-solvent ink formulations produce durable prints that resist fading for up to three years without lamination and are scratch, smear, and crack resistant<sup>4</sup>.
- **Premium image quality - HP printing materials designed with HP low-solvent inks.** With HP Premium Scrim Banner, HP Universal Scrim Banner, HP Premium Backlit Film, HP Blue Back Satin Billboard Paper, HP Satin Canvas, and HP Translucent PVC Display Film, get premium image quality and high opacity.

## Better business, more profits

- **Successfully compete against screen print shops for those shorter run lengths.** Yes; it's true! Better business and more profits are a reality with this printer. High print speeds and low printing costs increase the break-even point against screen printers, making it easier to compete, and creating a huge opportunity in the outdoor printing market.
- **Minimize your costs and get lasting output on uncoated media.** Count on excellent quality output on a range of low cost, uncoated materials, such as adhesive vinyls, films, banner stocks, papers, and fabrics.

## Safety and support - at HP, your needs come first

- **Have a clean, safe print environment with an integrated air purifier created for HP Designjets.** This printer-connected system uses a sealed, carbon-activated filter and high-powered fan to filter air at a rate consistent with the print speed and the number of volatile organic compounds released during the printing process.
- **HP guidelines help make HP low-solvent ink printing safe, productive, and easy.** Following HP's installation and use guidelines helps you achieve a reliable and productive low-solvent ink printing solution and helps you address environmental, health, and safety questions about printing with HP low-solvent inks. To learn more, visit [www.hp.com/go/ehs](http://www.hp.com/go/ehs).
- **Designed together for HP quality and reliability.** The HP Designjet printing system - printers, low-solvent inks, ink cartridges, printheads, and printing material - is engineered to work with precision and must meet strict HP quality standards. Reliable operation saves you time and improves your productivity.
- **HP offers the cleaning supplies and replacement ink cartridges needed to maintain your system.** HP training and guidelines help you implement environmentally responsible and safe practices for the purchase, installation, operation, handling, and maintenance of HP low-solvent printing supplies.
- **Experience peace of mind, knowing you're covered with HP's award-winning service and support.** HP's customer service and support backs every product with fast, knowledgeable online e-Support available 24/7 at [www.hp.com/support](http://www.hp.com/support), and easy-to-access phone support provided by HP trained agents. Plus, you can enhance your warranty protection with the purchase of affordable HP Care Pack Services.



1000 ml HP Ink Supplies



Adjustable vacuum system



Easy media loading

<sup>1</sup> Compared to other large-format printers within the same price range. Based on the recognized standard printing mode in the digital print industry-720 dpi with four passes per color-published by manufacturers as of December 2005.

<sup>2</sup> Using genuine HP supplies ensures availability of all HP printing features.

<sup>3</sup> HP "low-solvent" inks are defined according to what is currently known in the industry as low-solvent inks.

<sup>4</sup> Image permanence and application durability under typical exposure in vertical display conditions and varies as environmental conditions change.

# HP Designjet 9000s Printer series

1. Up to 1626 mm wide
2. Six HP 790 ink cartridges, 1000 ml each with "hot-swap", which allows you to change an ink cartridge without interrupting the print job
3. Heavy-duty HP Take-Up Reel with four winding modes
4. Two interactive front panel
5. USB 2.0 Hi-speed connectivity
6. 3 user-controllable integrated heaters
7. Easy media-loading
8. Exhaust attachment for efficient removal of Volatile Organic Compounds (VOC) included in the printer box
9. Printhead height adjustable to 2 different positions
10. Adjustable vacuum system to match media width

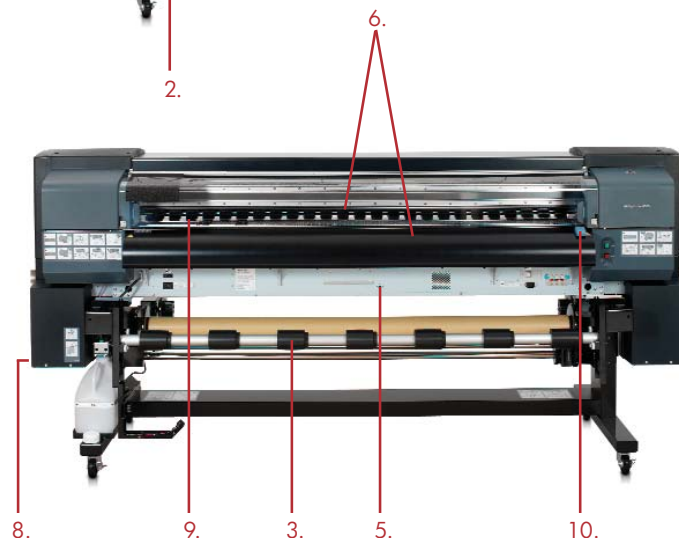
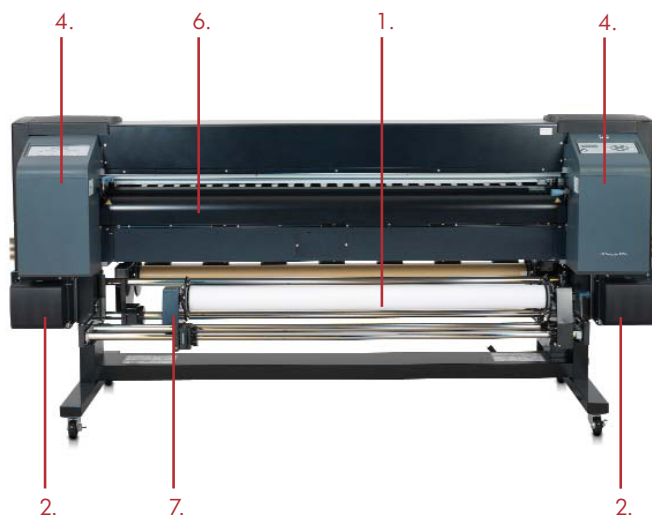

## HP Designjet 9000s Printer series at a glance

### HP Designjet 9000s Printer

#### In the box

HP Designjet 9000s Printer (with stand assembled)  
including Take-Up Reel

#### Optional accessories

- HP Designjet Air Purifier System
- HP Designjet High Speed Dryer
- Onyx® PosterShop® 7.0 for HP Designjet
- Media cover for HP Designjet 9000s series
- HP Designjet APS Filter



Detail on Take-Up Reel with four winding modes

The HP Designjet 9000s Printer series, HP low-solvent ink cartridges, and printing material were all designed, engineered and tested together to ensure uncompromising reliability, image quality, durability, performance and ease of use. The total HP printing solution is composed of the following accessories:

### HP Designjet Air Purifier System

Put your confidence in HP. Add this air purifier system (APS) - specially designed for HP low-solvent inks - to your HP Designjet printer for highly efficient air filtration. The APS includes the tubes that connect to the printer.

Count on HP for a clean, safe\* print environment

- **Highly effective carbon filter removes hazardous substances released from solvent inks.**
- **Return cleaned air to the working area or divert it outside.** This air purification system is equipped with a standard sealing device, and collected pollutants are led automatically through the filter.

Easily operate with front-panel display unit

- **Access air purification system data through a front-panel display unit.**
- **Easily replace the filter through the front door on the system.**

\* When used appropriately, according to the product's guidelines.



### HP Designjet High Speed Dryer

Add this high-speed dryer to your HP Designjet 9000s Printer and accelerate drying time.

Improve productivity - dryer reduces drying time

- **Dry prints as quickly as the automatic take-up reel can roll them up.** With the high-speed dryer and take-up reel, you can complete jobs at a rate of up to 29.9 m<sup>2</sup>/hour. The integrated dryer and take-up reel enable unattended print runs.

Easily operate high-speed dryer

- **Completely dry prints with user-adjustable heater and blower unit.** Use variable controls on top of the dryer unit to set the heater temperature and to adjust the fan airflow.
- **Dryer's off timer allows unattended drying for up to 12 hours**

Count on a dryer that was designed for safety

- **Built for high-volume, commercial print environments**



### Onyx® PosterShop® 7.0 for HP Designjet

Use this Onyx® PosterShop® RIP to print job after job of the best colors your printer can produce. Efficiently manage jobs and handle production with job preflight and printer queue tools.

Print the colors your customers expect

- **Make color changes - to precise spots or entire images - with intuitive color correction tools**
- **Have CMYK colors pop with PosterColor color rendering**

Print and customize jobs quickly and easily

- **Modify jobs and see final layout on your screen before printing with easy-to-use preflight controls technology by Onyx®**
- **Print directly from your creative applications or from Hot Folders that specify job properties**
- **Add cut marks to your print jobs easier than ever with this RIP's contour cutting workflow**

Manage media and calibrate your printer as needed

- **Use the RIP's default media calibration tables, or add and calibrate your own printing materials**



Complete Solution

# HP Designjet 9000s Printer series

## Technical specifications

<b>Print speed</b>	
High quality	8.17 m <sup>2</sup> /h, color image on vinyl media
Normal	16.35 m <sup>2</sup> /h, color image on vinyl media
Draft normal	20.4 m <sup>2</sup> /h, color image on vinyl media
Fast	29.9 m <sup>2</sup> /h, color image on vinyl media
<b>Print resolution maximum</b>	720 x 720 dpi
<b>Print margins</b>	
Normal	(Top x bottom x right x left): 5 x 5 x 5 x 5 mm
Using paper edge guard	(Top x bottom x right x left): 5 x 10 x 5 x 10 mm
<b>Memory</b>	192 MB
<b>Media</b>	
Handling	Roll to roll, 4 position support take-up reel
Types	Paper, vinyl, banner scrim, films, fabrics
Thickness	0.07 - 0.63 mm
Printhead height	2.1 to 2.6 mm
Maximum width	1626 mm
Maximum roll weight	24 kg
<b>Printing</b>	
Technology	Piezo-electric inkjet heads
Technology resolution	720 x 720 dpi
Print cartridge colors	Cyan, magenta, yellow, black, light cyan, light magenta
Ink types	HP low-solvent inks
Ink drop	12 pl
Ink cartridge size	1000 ml per color
Nozzles	512 nozzles per head x 6 colors
Maximum print length	45.7 m (RIP dependent)
Print accuracy	± 0.3% or ± 5 mm whichever is larger
<b>Heater</b>	
Integrated	3 independent heating systems
Heater locations	Front, print and rear areas
Heater settable temperature	15 to 55 °C
<b>Interfaces (Standard)</b>	USB 2.0 Hi-speed
<b>Dimensions (w x d x h)</b>	
Printer	2540 x 861 x 1201 mm
Shipping	2720 x 1020 x 1420 mm
<b>Weight</b>	
Printer	229 kg
Shipping	287 kg
<b>What's in the box</b>	
HP Designjet 9000s Printer	HP Designjet 9000s Printer (with stand assembled), waste ink bottle (2), take-up reel, tension bar for take-up reel, coated paper, paper tube, screwdriver for assembly, cleaning kit, start-up ink cartridges (6 x 500 ml), exhaust attachment kit, power cord for printer, power cord for heater, user guide CD, USB cable, rubber gloves

### Environmental ranges

Recommended operating temperature	15 to 30 °C
Storage temperature	5 to 35 °C
Recommended humidity range	30 to 70% RH

### Acoustic

Sound pressure, active	60 dB (A)
Sound pressure, standby	45 dB (A)

### Power consumption

Printer active	200 watts
Printer with Heater active	1440 watts
Printer standby	40 watts
Heater standby	2 watts

### Power requirements

Printer	Input voltage 100 to 127 VAC (+/-10%), 50/60 Hz +/- 1 Hz, 2 amp; 220-240 VAC (+/-10%), 50/60 Hz +/- 1 Hz, 1 amp
Heater	Input voltage 100 to 127 VAC (+/-10%), 50/60 Hz +/- 1 Hz, 12 amp; 220-240 VAC (+/-10%), 50/60 Hz +/- 1 Hz, 6 amp

### Certification

Safety certification	Compliant with IEC 60950, including EU LVD and EN60950, CSA certified for US and Canada, Mexico NYCE, Argentina IRAM, Singapore PSB, Russia VNIIS, Poland EL TEST
Electromagnetic certification	Compliant with Class A requirements including EU (EMC Directive), USA (FCC rules), Canada (DoC), Australia (ACA), New Zealand (MoCo), Japan (VCCI), Korea (MIC), Taiwan (BSMI)
Environmental certification	WEEE, ROHS

### Warranty

Printer	One year system warranty
Printheads	One year warranty

## Accessories - technical specifications

### HP Designjet Air Purifier System

<b>What's in the box</b>	HP Designjet Air Purifier unit with 2 filter elements inside, APS printer connection set, user's guide, power cord in compliance with regional power
<b>Product weight</b>	95 kg plus tube connections
<b>Package weight</b>	115 kg
<b>Product dimensions</b>	365 x 801 x 797 mm
<b>Package dimensions</b>	570 x 900 x 1140 mm
<b>Power consumption</b>	1600 watts
<b>Fan power</b>	360 m <sup>3</sup> /hr

### HP Designjet High Speed Dryer

<b>What's in the box</b>	Dryer unit, support stay, foot with castor (2), stand (2), M5 x 12L hexagon socket head bolt (16), hexagon bar wrench, user's guide, power cord in compliance with regional power
<b>Product weight</b>	40 kg
<b>Package weight</b>	60 kg
<b>Product dimensions</b>	2416 x 612 x 903 mm
<b>Package dimensions</b>	2530 x 690 x 335 mm
<b>Power consumption</b>	2750 watts

## Minimum PC operating system requirements for the Onyx® PosterShop® 7.0 for HP Designjet

Windows XP Pro with latest SP, Windows 2000 Pro with latest SP, Intel Pentium 3 or higher, Athlon, 2.5 GHz or higher, Dual CPC for multiple RIPs, one 80 GB Hard Drive (preferably two 80 GB Hard Drives for optimal performance), 1 GB RAM per CPU, 1280 x 768 16 bit color display, one USB Port required for security key, DVD-ROM drive

### Ordering information

<b>Product</b>	Q6665A HP Designjet 9000s Printer
<b>Accessories</b>	Q6668E HP Designjet Air Purifier System 220V Q6668F HP Designjet Air Purifier System 110V Q6667A HP Designjet High Speed Dryer Q6669B Onyx® PosterShop® 7.0 for HP Designjet Q6680A Media cover for HP Designjet 9000s series Q6710A HP Designjet Air Purifier System Filter
<b>Service &amp; Support care packs</b>	UD916A/E 3 year Next-Day Onsite - onsite next day support UD917A/E 4 year Next-Day Onsite - onsite next day support UD918A/E 5 year Next-Day Onsite - onsite next day support UD919A/E 3 year 9x5 Same-Day Onsite - onsite support in 4 hours UD920A/E 4 year 9x5 Same-Day Onsite - onsite support in 4 hours UD921A/E 5 year 9x5 Same-Day Onsite - onsite support in 4 hours UD922A/E 3 year 13x5 Same-Day Onsite - onsite support in 4 hours UD923A/E 4 year 13x5 Same-Day Onsite - onsite support in 4 hours UD924A/E 5 year 13x5 Same-Day Onsite - onsite support in 4 hours UD925PA/E 9x5 Next day onsite - 1-Year post warranty UD926PA/E 9x5 Same-day onsite - 1-Year post warranty UD927PA/E 13x5 Same-day onsite - 1-Year post warranty
<b>Ink supplies</b>	
<b>Cartridges</b>	CB271A HP 790 Black Ink Cartridge, 1000 ml CB272A HP 790 Cyan Ink Cartridge, 1000 ml CB273A HP 790 Magenta Ink Cartridge, 1000 ml CB274A HP 790 Yellow Ink Cartridge, 1000 ml CB275A HP 790 Light Cyan Ink Cartridge, 1000 ml CB276A HP Light Magenta Ink Cartridge, 1000 ml
<b>Waste Ink Bottle</b>	CB299A HP 790 Waste Ink Bottle
<b>Maintenance Kits</b>	CB293A HP 790 Wiper Cleaning Kit CB294A HP 790 Cap Cleaning Kit CB296A HP 790 Ink System Cleaning Kit CB297A HP 790 Ink System Storage Kit
<b>Media supplies (available in Europe)</b>	Q8678AE HP Premium Scrim Banner 914 mm x 50 m Q8679AE HP Premium Scrim Banner 1372 mm x 30.5 m Q8680AE HP Universal Scrim Banner 914 mm x 50 m Q8681AE HP Universal Scrim Banner 1372 mm x 30.5 m Q8682AE HP Premium Self-adhesive Vinyl 1372 mm x 45.7 m Q8683AE HP Premium Self-adhesive Vinyl 1524 mm x 45.7 m Q8684AE HP Premium Backlit Film 914 mm x 20.1 m Q8685AE HP Premium Backlit Film 1372 mm x 20.1 m Q8686AE HP Universal Photo-realistic Paper 914 mm x 45.7 m Q8687AE HP Universal Photo-realistic Paper 1372 mm x 45.7 m
<b>Media supplies (available in Europe March 07)</b>	Q8782AE HP Blue Back Satin Billboard Paper 1372 mm x 61 m Q8832AE HP Blue Back Satin Billboard Paper 1626 mm x 61 m Q8838AE HP Satin Canvas 914 mm x 14.9 m Q8783AE HP Satin Canvas 1372 mm x 14.9 m Q8833AE HP Satin Canvas 1524 mm x 14.9 m Q8781AE HP Translucent PVC Display Film 914 mm x 30.5 m Q8830AE HP Translucent PVC Display Film 1372 mm x 30.5 m Q8831AE HP Translucent PVC Display Film 1524 mm x 30.5 m Q8775AE HP Universal Scrim Banner 1626 mm x 30.5 m

More HP media sizes available at [www.hp.com/go/designjet/supplies](http://www.hp.com/go/designjet/supplies)

For more information, visit our website at  
[www.hp.com/go/designjet9000s](http://www.hp.com/go/designjet9000s)

Microsoft and Windows are U.S. registered trademarks of Microsoft Corporation.  
© 2006 Hewlett-Packard Development Company, L.P. The information contained herein is subject to change without notice. The only warranties for HP products and services are set forth in the express warranty statements accompanying such products and services. Nothing herein should be construed as constituting an additional warranty. HP shall not be liable for technical or editorial errors or omissions contained herein.