



Lexmark™

CS943 Printer

User's Guide

October 2022

www.lexmark.com

Machine type:

5080

Model:

435

Contents

- Safety information..... 5**
 - Conventions..... 5
 - Product statements..... 5

- Learn about the printer..... 8**
 - Finding information about the printer.....8
 - Finding the printer serial number..... 9
 - Printer configurations.....10
 - Using the control panel..... 12
 - Understanding the status of the indicator light.....12
 - Selecting paper.....13

- Set up, install, and configure..... 33**
 - Selecting a location for the printer..... 33
 - Attaching cables..... 34
 - Setting up and using the home screen applications..... 35
 - Setting up and using the accessibility features.....39
 - Loading paper and specialty media..... 41
 - Installing and updating software, drivers, and firmware..... 58
 - Installing hardware options..... 61
 - Networking..... 160

- Secure the printer..... 164**
 - Locating the security slot..... 164
 - Erasing printer memory..... 164
 - Erasing printer storage drive..... 165
 - Restoring factory default settings.....165
 - Statement of Volatility..... 165

- Print..... 167**
 - Printing from a computer..... 167
 - Printing from a mobile device..... 167
 - Printing a booklet.....169
 - Printing from a flash drive.....169
 - Supported flash drives and file types..... 170

Configuring confidential jobs..... 171

Printing confidential and other held jobs..... 171

Printing a font sample list..... 172

Printing a directory list..... 172

Placing separator sheets between copies..... 172

Stapling printed sheets..... 172

Punching holes in printed sheets..... 173

Folding printed sheets..... 173

Using offset stacking in printed sheets..... 174

Canceling a print job..... 174

Adjusting toner darkness..... 174

Use printer menus..... 175

Menu map..... 175

Device..... 176

Print..... 186

Paper..... 196

USB Drive..... 198

Network/Ports..... 200

Security..... 213

Cloud Services..... 219

Reports..... 220

Troubleshooting..... 221

Printing the Menu Settings Page..... 221

Maintain the printer..... 222

Checking the status of parts and supplies..... 222

Configuring supply notifications..... 222

Setting up e-mail alerts..... 222

Viewing reports..... 223

Ordering parts and supplies..... 223

Replacing parts and supplies..... 224

Cleaning printer parts..... 304

Saving energy and paper..... 322

Moving the printer to another location..... 323

Shipping the printer..... 323

Troubleshoot a problem..... 324

Print quality problems..... 324

Printer error codes.....325

Printing problems..... 331

The printer is not responding..... 356

Unable to read flash drive..... 357

Enabling the USB port..... 357

Clearing jams..... 358

Network connection problems..... 391

Hardware options problems..... 393

Issues with supplies..... 395

Paper feed problems..... 396

Color quality problems..... 399

Contacting customer support..... 401

Recycle and dispose..... 402

Recycling Lexmark products.....402

Recycling Lexmark packaging.....402

Notices..... 403

Index..... 413

Safety information

Conventions

Note: A *note* identifies information that could help you.

Warning: A *warning* identifies something that could damage the product hardware or software.

CAUTION: A *caution* indicates a potentially hazardous situation that could injure you.

Different types of caution statements include:



CAUTION—POTENTIAL INJURY: Indicates a risk of injury.



CAUTION—SHOCK HAZARD: Indicates a risk of electrical shock.



CAUTION—HOT SURFACE: Indicates a risk of burn if touched.



CAUTION—TIPPING HAZARD: Indicates a crush hazard.



CAUTION—PINCH HAZARD: Indicates a risk of being caught between moving parts.

Product statements



CAUTION—POTENTIAL INJURY: To avoid the risk of fire or electrical shock, connect the power cord to an appropriately rated and properly grounded electrical outlet that is near the product and easily accessible.



CAUTION—POTENTIAL INJURY: To avoid the risk of fire or electrical shock, use only the power cord provided with this product or the manufacturer's authorized replacement.



CAUTION—POTENTIAL INJURY: Do not use this product with extension cords, multioutlet power strips, multioutlet extenders, or UPS devices. The power capacity of these types of accessories can be easily overloaded by a laser printer and may result in a risk of fire, property damage, or poor printer performance.



CAUTION—POTENTIAL INJURY: Only a Lexmark Inline Surge Protector that is properly connected between the printer and the power cord provided with the printer may be used with this product. The use of non-Lexmark surge protection devices may result in a risk of fire, property damage, or poor printer performance.











CAUTION—SHOCK HAZARD: To avoid the risk of electrical shock, do not place or use this product near water or wet locations.



CAUTION—SHOCK HAZARD: To avoid the risk of electrical shock, do not set up this product or make any electrical or cabling connections, such as the power cord, fax feature, or telephone, during a lightning storm.



CAUTION—POTENTIAL INJURY: Do not cut, twist, bind, crush, or place heavy objects on the power cord. Do not subject the power cord to abrasion or stress. Do not pinch the power cord between objects such as furniture and walls. If any of these things happen, a risk of fire or electrical shock results. Inspect the power cord regularly for signs of such problems. Remove the power cord from the electrical outlet before inspecting it.

-  **CAUTION—SHOCK HAZARD:** To avoid the risk of electrical shock, make sure that all external connections (such as Ethernet and telephone system connections) are properly installed in their marked plug-in ports.
-  **CAUTION—SHOCK HAZARD:** To avoid the risk of electrical shock, if you are accessing the controller board or installing optional hardware or memory devices sometime after setting up the printer, then turn the printer off, and unplug the power cord from the electrical outlet before continuing. If you have any other devices attached to the printer, then turn them off as well, and unplug any cables going into the printer.
-  **CAUTION—SHOCK HAZARD:** To avoid the risk of electrical shock when cleaning the exterior of the printer, unplug the power cord from the electrical outlet and disconnect all cables from the printer before proceeding.
-  **CAUTION—POTENTIAL INJURY:** If the printer weight is greater than 20 kg (44 lb), then it may require two or more people to lift it safely.
-  **CAUTION—POTENTIAL INJURY:** When moving the printer, follow these guidelines to avoid personal injury or printer damage:
- Make sure that all doors and trays are closed.
 - Turn off the printer, and then unplug the power cord from the electrical outlet.
 - Disconnect all cords and cables from the printer.
 - If the printer has separate floor-standing optional trays or output options attached to it, then disconnect them before moving the printer.
 - If the printer has a caster base, then carefully roll it to the new location. Use caution when passing over thresholds and breaks in flooring.
 - If the printer does not have a caster base but is configured with optional trays or output options, then remove the output options and lift the printer off the trays. Do not try to lift the printer and any options at the same time.
 - Always use the handholds on the printer to lift it.
 - Any cart used to move the printer must have a surface able to support the full footprint of the printer.
 - Any cart used to move the hardware options must have a surface able to support the dimensions of the options.
 - Keep the printer in an upright position.
 - Avoid severe jarring movements.
 - Make sure that your fingers are not under the printer when you set it down.
 - Make sure that there is adequate clearance around the printer.
-  **CAUTION—TIPPING HAZARD:** Installing one or more options on your printer or MFP may require a caster base, furniture, or other feature to prevent instability causing possible injury. For more information on supported configurations, see www.lexmark.com/multifunctionprinters.
-  **CAUTION—TIPPING HAZARD:** To reduce the risk of equipment instability, load each tray separately. Keep all other trays closed until needed.
-  **CAUTION—HOT SURFACE:** The inside of the printer might be hot. To reduce the risk of injury from a hot component, allow the surface to cool before touching it.
-  **CAUTION—PINCH HAZARD:** To avoid the risk of a pinch injury, use caution in areas marked with this label. Pinch injuries may occur around moving parts, such as gears, doors, trays, and covers.



CAUTION—POTENTIAL INJURY: The lithium battery in this product is not intended to be replaced. There is a danger of explosion if a lithium battery is incorrectly replaced. Do not recharge, disassemble, or incinerate a lithium battery. Discard used lithium batteries according to the manufacturer's instructions and local regulations.

This product is designed, tested, and approved to meet strict global safety standards with the use of specific manufacturer's components. The safety features of some parts may not always be obvious. The manufacturer is not responsible for the use of other replacement parts.

Refer service or repairs, other than those described in the user documentation, to a service representative.

SAVE THESE INSTRUCTIONS.

Learn about the printer

Finding information about the printer

What are you looking for?	Find it here
Initial setup instructions	See the setup documentation that came with the printer.
<ul style="list-style-type: none"> • Printer software • Print or fax driver • Printer firmware • Utility 	Go to www.lexmark.com/downloads , search for your printer model, and then in the Type menu, select the driver, firmware, or utility that you need.
<ul style="list-style-type: none"> • Selecting and storing paper and specialty media • Loading paper • Configuring printer settings • Viewing and printing documents and photos • Configuring the printer on a network • Caring for and maintaining the printer • Troubleshooting and solving problems 	Information Center—Go to https://infoserve.lexmark.com . How-to videos—Go to https://infoserve.lexmark.com/idv/ . Touch Screen Guide—Go to http://support.lexmark.com .
Setting up and configuring the accessibility features of your printer	<i>Lexmark Accessibility Guide</i> —Go to http://support.lexmark.com .
Help information for using the printer software.	Help for Microsoft Windows or Macintosh operating systems—Open a printer software program or application, and then click Help . Click  to view context-sensitive information. Notes: <ul style="list-style-type: none"> • Help is automatically installed with the printer software. • Depending on the operating system, the printer software is either in the printer program folder or on the desktop.

What are you looking for?	Find it here
<ul style="list-style-type: none"> • Documentation • Live chat support • E-mail support • Voice support 	<p>Go to http://support.lexmark.com.</p> <p>Note: Select your country or region, and then select your product to view the appropriate support site.</p> <p>Support contact information for your country or region can be found on the website or on the printed warranty that came with the printer.</p> <p>Have the following information ready when you contact customer support:</p> <ul style="list-style-type: none"> • Place and date of purchase • Machine type and serial number <p>For more information, see “Finding the printer serial number” on page 9.</p>
<ul style="list-style-type: none"> • Safety information • Regulatory information • Warranty information • Environmental information 	<p>Warranty information varies by country or region:</p> <ul style="list-style-type: none"> • In the U.S.—See the Statement of Limited Warranty included with the printer, or go to http://support.lexmark.com. • In other countries and regions—See the printed warranty that came with the printer. <p><i>Product Information Guide</i>—See the documentation that came with the printer or go to http://support.lexmark.com.</p>
Information on Lexmark digital passport	Go to https://csr.lexmark.com/digital-passport.php .

Finding the printer serial number

- 1 Open the front door.

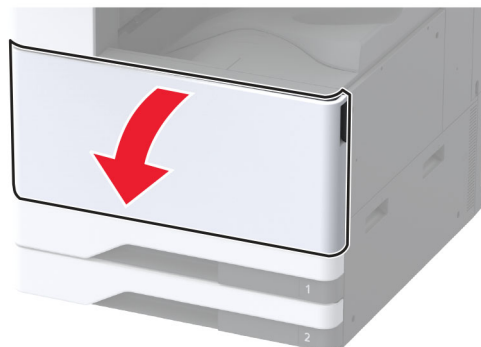

2 Locate the serial number at the left side of the printer.



Printer configurations

Note: Make sure to configure the printer on a flat, sturdy, and stable surface.

Basic model

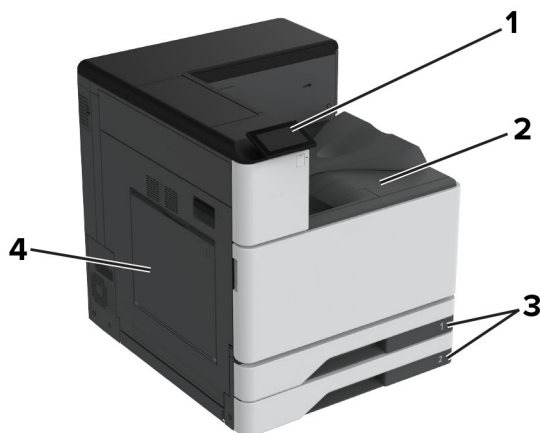

1	Control panel
2	Standard bin
3	Standard 2 x 520-sheet tray
4	Multipurpose feeder

Configured model

CAUTION—TIPPING HAZARD: Installing one or more options on your printer or MFP may require a caster base, furniture, or other feature to prevent instability causing possible injury. For more information on supported configurations, see www.lexmark.com/multifunctionprinters.

CAUTION—TIPPING HAZARD: To reduce the risk of equipment instability, load each tray separately. Keep all other trays closed until needed.

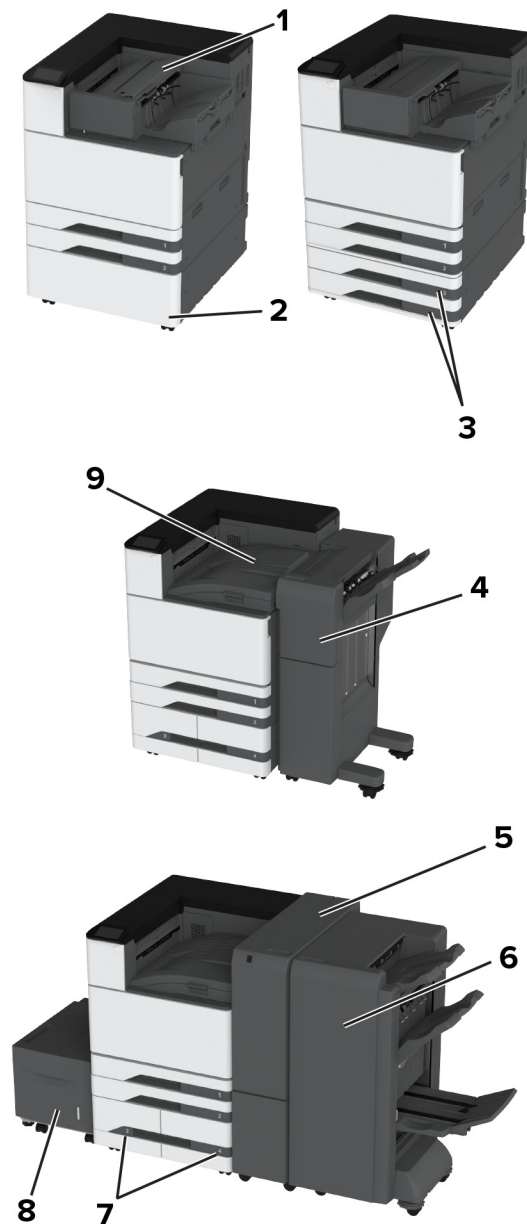

1	Staple finisher Note: Not supported if another finisher is installed.
2	Optional spacer
3	Optional 2 x 520-sheet tray

4	Staple, hole punch finisher Note: Supported only if an optional tray or spacer is installed.
5	Trifold/Z-fold finisher Note: Supported only if an optional tray or spacer is installed.
6	Booklet finisher Note: Supported only if an optional tray or spacer is installed.
7	Optional 2000-sheet tandem tray
8	Optional 2000-sheet tray
9	Paper transport Note: Comes with the booklet finisher or staple, hole punch finisher.

Using the control panel



	Control panel part	Function
1	Power button	<ul style="list-style-type: none"> Turn on or turn off the printer. <p>Note: To turn off the printer, press and hold the power button for five seconds.</p> <ul style="list-style-type: none"> Set the printer to Sleep or Hibernate mode. Wake the printer from Sleep or Hibernate mode.
2	Display	<ul style="list-style-type: none"> View the printer messages and supply status. Set up and operate the printer.
3	Indicator light	Check the status of the printer.

Understanding the status of the indicator light

Indicator light	Printer status
Off	The printer is off.
Solid blue	The printer is ready.
Blinking blue	The printer is printing or processing data.
Blinking red	The printer requires user intervention.
Solid amber	The printer is in Sleep mode.

Indicator light	Printer status
Blinking amber	The printer is in Deep Sleep or Hibernate mode.

Selecting paper

Paper guidelines

Use the appropriate paper to prevent jams and help ensure trouble-free printing.

- Always use new, undamaged paper.
- Before loading paper, know the recommended printable side of the paper. This information is usually indicated on the paper package.
- Do not use paper that has been cut or trimmed by hand.
- Do not mix paper sizes, types, or weights in the same tray; mixing results in jams.
- Do not use coated papers unless they are specifically designed for electrophotographic printing.

For more information, see the *Paper and Specialty Media Guide*.

Paper characteristics

The following paper characteristics affect print quality and reliability. Consider these factors before printing on them.

Weight

Trays can feed paper of varying weights. Paper lighter than 60 g/m² (16 lb) may not be stiff enough to feed properly, and may cause jams. For more information, see the “Supported paper weights” topic.

Curl

Curl is the tendency for paper to curl at its edges. Excessive curl can cause paper feeding problems. Curl can occur after the paper passes through the printer, where it is exposed to high temperatures. Storing paper unwrapped in hot, humid, cold, or dry conditions can contribute to paper curling before printing and can cause feeding problems.

Smoothness

Paper smoothness directly affects print quality. If paper is too rough, toner cannot fuse to it properly. If paper is too smooth, it can cause paper feeding or print quality issues. We recommend the use of paper with 50 Sheffield points.

Moisture content

The amount of moisture in paper affects both print quality and the printer ability to feed the paper correctly. Leave paper in its original wrapper until you use it. Exposure of paper to moisture changes can degrade its performance.

Before printing, store paper in its original wrapper for 24 to 48 hours. The environment in which the paper is stored must be the same as the printer. Extend the time several days if the storage or transportation environment is very different from the printer environment. Thick paper may also require a longer conditioning period.

Grain direction

Grain refers to the alignment of the paper fibers in a sheet of paper. Grain is either *grain long* which runs the length of the paper, or *grain short* which runs the width of the paper. For recommended grain direction, see the “Supported paper weights” topic.

Fiber content

Most high-quality xerographic paper is made from 100 percent chemically treated pulped wood. This content provides the paper with a high degree of stability, resulting in fewer paper feeding problems and better print quality. Paper containing fibers such as cotton can negatively affect paper handling.

Unacceptable paper

The following paper types are not recommended for use with the printer:

- Chemically treated papers that are used to make copies without carbon paper. They are also known as carbonless papers, carbonless copy paper (CCP), or no carbon required (NCR) paper.
- Preprinted papers with chemicals that may contaminate the printer.
- Preprinted papers that can be affected by the temperature in the printer fuser.
- Preprinted papers that require a registration (the precise print location on the page) greater than ± 2.3 mm (± 0.09 in.). For example, optical character recognition (OCR) forms.

Sometimes, registration can be adjusted with a software app to print successfully on these forms.

- Coated papers (erasable bond), synthetic papers, or thermal papers.
- Rough-edged, rough or heavily textured surface papers, or curled papers.
- Recycled papers that fail EN12281:2002 (European).
- Paper weighing less than 60 g/m² (16 lb).
- Multiple-part forms or documents.

Storing paper

Use these paper storage guidelines to help avoid jams and uneven print quality:

- Store paper in its original wrapper in the same environment as the printer for 24 to 48 hours before printing.
- Extend the time several days if the storage or transportation environment is very different from the printer environment. Thick paper may also require a longer conditioning period.
- For best results, store paper where the temperature is 21°C (70°F) and the relative humidity is 40 percent.
- Most label manufacturers recommend printing in a temperature range of 18–24°C (65–75°F) with relative humidity between 40 and 60 percent.
- Store paper in cartons, on a pallet or shelf, rather than on the floor.
- Store individual packages on a flat surface.

- Do not store anything on top of individual paper packages.
- Take paper out of the carton or wrapper only when you are ready to load it in the printer. The carton and wrapper help keep the paper clean, dry, and flat.

Selecting preprinted forms and letterhead

- Use grain long paper.
- Use only forms and letterhead printed using an offset lithographic or engraved printing process.
- Avoid paper with rough or heavily textured surfaces.
- Use inks that are not affected by the resin in toner. Inks that are oxidation-set or oil-based generally meet these requirements; latex inks might not.
- Print samples on preprinted forms and letterheads considered for use before buying large quantities. This action determines whether the ink in the preprinted form or letterhead affects print quality.
- When in doubt, contact your paper supplier.
- When printing on letterhead, load the paper in the proper orientation for your printer. For more information, see the *Paper and Specialty Media Guide*.

Supported paper sizes

Paper sizes supported by the standard tray, MPF, envelope tray, and two-sided printing

Paper size	Standard 2 x 520-sheet tray	Multipurpose feeder	Envelope tray	Two-sided printing
A3¹ 297 x 420 mm (11.69 x 16.54 in.)	✓	✓	X	✓
A4 210 x 297 mm (8.27 x 11.7 in.)	✓	✓ ²	X	✓
A5 148 x 210 mm (5.83 x 8.27 in.)	✓ ¹	✓ ²	X	✓
A6 105 x 148 mm (4.13 x 5.83 in.)	✓ ¹	✓ ¹	X	X

¹ Loads only in short-edge orientation.

² Loads only in long-edge orientation.

³ Supports paper sizes ranging from 99.99 x 147.99 mm (3.93 x 5.83 in.) to 296.93 x 431.8 mm (11.69 x 17 in.).

⁴ Supports paper sizes ranging from 88.9 x 98.38 mm (3.5 x 3.87 in.) to 320.04 x 1320.8 mm (12.6 x 52 in.).

⁵ Supports paper sizes ranging from 128 x 139.7 mm (5 x 5.5 in.) to 320.04 x 482.6 mm (12.6 x 19 in.).

⁶ Supported only in tray 2.

Paper size	Standard 2 x 520-sheet tray	Multipurpose feeder	Envelope tray	Two-sided printing
Arch B 304.8 x 457.2 mm (12 x 18 in.)	√ ⁶	√	X	X
Executive 184.2 x 266.7 mm (7.25 x 10.5 in.)	√	√ ²	X	√
Folio ¹ 215.9 x 330.2 mm (8.5 x 13 in.)	√	√	X	√
Hagaki 100 x 148 mm (3.94 x 5.83 in.)	X	√ ¹	X	X
JIS B4 ¹ 257 x 364 mm (10.12 x 14.33 in.)	√	√	X	√
JIS B5 182 x 257 mm (7.17 x 10.1 in.)	√	√ ²	X	√
Ledger ¹ 279.4 x 4431.8 mm (11 x 17 in.)	√	√	X	√
Legal ¹ 215.9 x 355.6 mm (8.5 x 14 in.)	√	√	X	√
Letter 215.9 x 279.4 mm (8.5 x 11 in.)	√	√ ²	X	√
Oficio (Mexico) ¹ 215.9 x 340.4 mm (8.5 x 13.4 in.)	√	√	X	√

¹ Loads only in short-edge orientation.

² Loads only in long-edge orientation.

³ Supports paper sizes ranging from 99.99 x 147.99 mm (3.93 x 5.83 in.) to 296.93 x 431.8 mm (11.69 x 17 in.).

⁴ Supports paper sizes ranging from 88.9 x 98.38 mm (3.5 x 3.87 in.) to 320.04 x 1320.8 mm (12.6 x 52 in.).

⁵ Supports paper sizes ranging from 128 x 139.7 mm (5 x 5.5 in.) to 320.04 x 482.6 mm (12.6 x 19 in.).

⁶ Supported only in tray 2.

Paper size	Standard 2 x 520-sheet tray	Multipurpose feeder	Envelope tray	Two-sided printing
SRA3 320.04 x 449.58 mm (12.6 x 17.7 in.)	√ ⁶	√	X	X
Statement 139.7 x 215.9 mm (5.5 x 8.5 in.)	√ ¹	√ ²	X	√
Universal	√ ³	√ ⁴	X	√ ⁵
7 3/4 Envelope 98.4 x 190.5 mm (3.875 x 7.5 in.)	X	√ ²	√	X
9 Envelope 98.4 x 225.4 mm (3.875 x 8.9 in.)	X	√ ²	√	X
10 Envelope 104.8 x 241.3 mm (4.12 x 9.5 in.)	X	√ ²	√	X
B5 Envelope 176 x 250 mm (6.93 x 9.84 in.)	X	√ ¹	√	X
C5 Envelope 162 x 229 mm (6.38 x 9.01 in.)	X	√ ²	√	X
DL Envelope 110 x 220 mm (4.33 x 8.66 in.)	X	√ ²	√	X

¹ Loads only in short-edge orientation.

² Loads only in long-edge orientation.

³ Supports paper sizes ranging from 99.99 x 147.99 mm (3.93 x 5.83 in.) to 296.93 x 431.8 mm (11.69 x 17 in.).

⁴ Supports paper sizes ranging from 88.9 x 98.38 mm (3.5 x 3.87 in.) to 320.04 x 1320.8 mm (12.6 x 52 in.).

⁵ Supports paper sizes ranging from 128 x 139.7 mm (5 x 5.5 in.) to 320.04 x 482.6 mm (12.6 x 19 in.).

⁶ Supported only in tray 2.

Paper sizes supported by the optional trays

Paper size	Optional 2 x 520-sheet tray	Optional 2000-sheet tandem tray	Optional 2000-sheet tray
A3¹ 297 x 420 mm (11.69 x 16.54 in.)	✓	X	X
A4 210 x 297 mm (8.27 x 11.7 in.)	✓	✓ ²	✓ ²
A5¹ 148 x 210 mm (5.83 x 8.27 in.)	✓ ₁	X	X
A6 105 x 148 mm (4.13 x 5.83 in.)	✓ ₁	X	X
Arch B 304.8 x 457.2 mm (12 x 18 in.)	✓	X	X
Executive 184.2 x 266.7 mm (7.25 x 10.5 in.)	✓	✓ ²	✓ ²
Folio¹ 215.9 x 330.2 mm (8.5 x 13 in.)	✓	X	X
Hagaki 100 x 148 mm (3.94 x 5.83 in.)	✓ ₁	X	X
JIS B4¹ 257 x 364 mm (10.12 x 14.33 in.)	✓ ₁	X	X
JIS B5 182 x 257 mm (7.17 x 10.1 in.)	✓	✓ ²	✓ ²
Ledger¹ 279.4 x 4431.8 mm (11 x 17 in.)	✓ ₁	X	X

¹ Loads only in short-edge orientation.

² Loads only in long-edge orientation.

³ Supports paper sizes ranging from 99.99 x 147.99 mm (3.93 x 5.83 in.) to 296.93 x 431.8 mm (11.69 x 17 in.).

⁴ Supports paper sizes ranging from 99.99 x 147.99 mm (3.93 x 5.83 in.) to 320.04 x 457.2 mm (12.6 x 18 in.).

Paper size	Optional 2 x 520-sheet tray	Optional 2000-sheet tandem tray	Optional 2000-sheet tray
Legal ¹ 215.9 x 355.6 mm (8.5 x 14 in.)	√ ₁	X	X
Letter 215.9 x 279.4 mm (8.5 x 11 in.)	√	√ ₂	√ ₂
Oficio (Mexico) ¹ 215.9 x 340.4 mm (8.5 x 13.4 in.)	√	X	X
SRA3 320.04 x 449.58 mm (12.6 x 17.7 in.)	√	X	X
Statement ¹ 139.7 x 215.9 mm (5.5 x 8.5 in.)	√ ₁	X	X
Universal	√ ₃	√ ₄	√ ₄
7 3/4 Envelope 98.4 x 190.5 mm (3.875 x 7.5 in.)	X	X	X
9 Envelope 98.4 x 225.4 mm (3.875 x 8.9 in.)	X	X	X
10 Envelope 104.8 x 241.3 mm (4.12 x 9.5 in.)	X	X	X
B5 Envelope 176 x 250 mm (6.93 x 9.84 in.)	X	X	X
C5 Envelope 162 x 229 mm (6.38 x 9.01 in.)	X	X	X
DL Envelope 110 x 220 mm (4.33 x 8.66 in.)	X	X	X

¹ Loads only in short-edge orientation.

² Loads only in long-edge orientation.

³ Supports paper sizes ranging from 99.99 x 147.99 mm (3.93 x 5.83 in.) to 296.93 x 431.8 mm (11.69 x 17 in.).

⁴ Supports paper sizes ranging from 99.99 x 147.99 mm (3.93 x 5.83 in.) to 320.04 x 457.2 mm (12.6 x 18 in.).

Paper sizes supported by the output bins

Paper size	Standard bin		Dual catch bin
	Stack	Offset	Stack
A3¹ 297 x 420 mm (11.69 x 16.54 in.)	✓	✓	✓
A4 210 x 297 mm (8.27 x 11.7 in.)	✓	✓	✓
A5 148 x 210 mm (5.83 x 8.27 in.)	✓	✓	✓
A6¹ 105 x 148 mm (4.13 x 5.83 in.)	✓	✓	✓
Arch B 304.8 x 457.2 mm (12 x 18 in.)	✓	x	✓
Banner Max width: 215.9 mm (8.5 in.) Max length: 1320.8 mm (52 in.)	✓	x	✓
Executive 184.2 x 266.7 mm (7.25 x 10.5 in.)	✓	✓	✓
Folio¹ 215.9 x 330.2 mm (8.5 x 13 in.)	✓	✓	✓
Hagaki¹ 100 x 148 mm (3.94 x 5.83 in.)	✓	✓	✓
JIS B4¹ 257 x 364 mm (10.12 x 14.33 in.)	✓	✓	✓
JIS B5 182 x 257 mm (7.17 x 10.1 in.)	✓	✓	✓

¹ Loads only in short-edge orientation.

² Loads only in long-edge orientation.

³ Supports paper sizes ranging from 88.9 x 98.38 mm (3.5 x 3.87 in.) to 320.04 x 1320.8 mm (12.6 x 52 in.).

⁴ Supports paper sizes ranging from 88.9 x 98.38 mm (3.5 x 3.87 in.) to 296.93 x 431.8 mm (11.69 x 17 in.).

Paper size	Standard bin		Dual catch bin
	Stack	Offset	Stack
Ledger ¹ 279.4 x 4431.8 mm (11 x 17 in.)	✓	✓	✓
Legal ¹ 215.9 x 355.6 mm (8.5 x 14 in.)	✓	✓	✓
Letter 215.9 x 279.4 mm (8.5 x 11 in.)	✓	✓	✓
Oficio (Mexico) ¹ 215.9 x 340.4 mm (8.5 x 13.4 in.)	✓	✓	✓
SRA3 320.04 x 449.58 mm (12.6 x 17.7 in.)	✓	x	✓
Statement 139.7 x 215.9 mm (5.5 x 8.5 in.)	✓	✓	✓
Universal	✓ ₃	✓ ₄	x
7 3/4 Envelope ² 98.4 x 190.5 mm (3.875 x 7.5 in.)	✓	✓	✓
9 Envelope ² 98.4 x 225.4 mm (3.875 x 8.9 in.)	✓	✓	✓
10 Envelope ² 104.8 x 241.3 mm (4.12 x 9.5 in.)	✓	✓	✓
B5 Envelope ² 176 x 250 mm (6.93 x 9.84 in.)	✓	✓	✓

¹ Loads only in short-edge orientation.

² Loads only in long-edge orientation.

³ Supports paper sizes ranging from 88.9 x 98.38 mm (3.5 x 3.87 in.) to 320.04 x 1320.8 mm (12.6 x 52 in.).

⁴ Supports paper sizes ranging from 88.9 x 98.38 mm (3.5 x 3.87 in.) to 296.93 x 431.8 mm (11.69 x 17 in.).

Paper size	Standard bin		Dual catch bin
	Stack	Offset	Stack
C5 Envelope ² 162 x 229 mm (6.38 x 9.01 in.)	✓	✓	✓
DL Envelope ² 110 x 220 mm (4.33 x 8.66 in.)	✓	✓	✓

¹ Loads only in short-edge orientation.
² Loads only in long-edge orientation.
³ Supports paper sizes ranging from 88.9 x 98.38 mm (3.5 x 3.87 in.) to 320.04 x 1320.8 mm (12.6 x 52 in.).
⁴ Supports paper sizes ranging from 88.9 x 98.38 mm (3.5 x 3.87 in.) to 296.93 x 431.8 mm (11.69 x 17 in.).

Paper sizes supported by the staple finisher and the staple, hole punch finisher

Paper size	Staple finisher			Staple, hole punch finisher			
	Stack	Offset	Staple	Stack	Offset	Staple	Hole punch
A3 ¹ 297 x 420 mm (11.69 x 16.54 in.)	✓	✓	✓	✓	✓	✓	✓
A4 210 x 297 mm (8.27 x 11.7 in.)	✓	✓	✓	✓	✓	✓	✓
A5 148 x 210 mm (5.83 x 8.27 in.)	✓	✓ ²	X	✓	✓ ²	✓ ²	✓ ⁶
A6 105 x 148 mm (4.13 x 5.83 in.)	✓	X	X	✓	X	X	X

¹ Loads only in short-edge orientation.
² Loads only in long-edge orientation.
³ Supports paper sizes ranging from 88.9 x 98.38 mm (3.5 x 3.87 in.) to 296.93 x 431.8 mm (11.69 x 17 in.).
⁴ Supports paper sizes ranging from 190 x 139.7 mm (7.48 x 5.5 in.) to 296.93 x 431.8 mm (11.69 x 17 in.).
⁵ Supports paper sizes ranging from 202.9 x 182.03 mm (7.99 x 7.17 in.) to 296.93 x 431.8 mm (11.69 x 17 in.).
⁶ Supports only up to two-hole punching.
⁷ Supports only up to two-hole punching when loaded in short-edge orientation.
⁸ Supports paper sizes ranging from 88.9 x 98.38 mm (3.5 x 3.87 in.) to 320.04 x 1320.8 mm (12.6 x 52 in.).
⁹ Supports paper sizes ranging from 209.97 x 148 mm (8.27 x 5.83 in.) to 296.93 x 431.8 mm (11.69 x 17 in.).

Paper size	Staple finisher			Staple, hole punch finisher			
	Stack	Offset	Staple	Stack	Offset	Staple	Hole punch
Arch B 304.8 x 457.2 mm (12 x 18 in.)	✓	X	X	✓	X	X	X
Banner Max width: 215.9 mm (8.5 in.) Max length: 1320.8 mm (52 in.)	✓ ¹	X	X	✓ ¹	X	X	X
Executive 184.2 x 266.7 mm (7.25 x 10.5 in.)	✓ ²	✓ ²	✓ ²	✓	✓ ²	✓ ²	✓ ²
Folio ¹ 215.9 x 330.2 mm (8.5 x 13 in.)	✓	✓	✓	✓	✓	✓	✓
Hagaki 100 x 148 mm (3.94 x 5.83 in.)	✓	X	X	✓	X	X	X
JIS B4 ¹ 257 x 364 mm (10.12 x 14.33 in.)	✓	✓	✓	✓	✓	✓	✓
JIS B5 182 x 257 mm (7.17 x 10.1 in.)	✓	✓ ²	✓ ²	✓	✓ ²	✓ ²	✓ ⁷
Ledger ¹ 279.4 x 4431.8 mm (11 x 17 in.)	✓	✓	✓	✓	✓	✓	✓
Legal ¹ 215.9 x 355.6 mm (8.5 x 14 in.)	✓	✓	✓	✓	✓	✓	✓

¹ Loads only in short-edge orientation.

² Loads only in long-edge orientation.

³ Supports paper sizes ranging from 88.9 x 98.38 mm (3.5 x 3.87 in.) to 296.93 x 431.8 mm (11.69 x 17 in.).

⁴ Supports paper sizes ranging from 190 x 139.7 mm (7.48 x 5.5 in.) to 296.93 x 431.8 mm (11.69 x 17 in.).

⁵ Supports paper sizes ranging from 202.9 x 182.03 mm (7.99 x 7.17 in.) to 296.93 x 431.8 mm (11.69 x 17 in.).

⁶ Supports only up to two-hole punching.

⁷ Supports only up to two-hole punching when loaded in short-edge orientation.

⁸ Supports paper sizes ranging from 88.9 x 98.38 mm (3.5 x 3.87 in.) to 320.04 x 1320.8 mm (12.6 x 52 in.).

⁹ Supports paper sizes ranging from 209.97 x 148 mm (8.27 x 5.83 in.) to 296.93 x 431.8 mm (11.69 x 17 in.).

Paper size	Staple finisher			Staple, hole punch finisher			
	Stack	Offset	Staple	Stack	Offset	Staple	Hole punch
Letter 215.9 x 279.4 mm (8.5 x 11 in.)	✓	✓	✓	✓	✓	✓	✓
Oficio (Mexico)¹ 215.9 x 340.4 mm (8.5 x 13.4 in.)	✓	✓	✓	✓	✓	✓	✓
SRA3 320.04 x 449.58 mm (12.6 x 17.7 in.)	✓	X	X	✓	X	X	X
Statement 139.7 x 215.9 mm (5.5 x 8.5 in.)	✓	✓ ²	X	X	X	X	X
Universal	✓ ³	✓ ⁴	✓ ⁵	✓ ⁸	✓ ⁹	✓ ⁹	X
7 3/4 Envelope 98.4 x 190.5 mm (3.875 x 7.5 in.)	✓	X	X	X	X	X	X
9 Envelope 98.4 x 225.4 mm (3.875 x 8.9 in.)	✓	X	X	X	X	X	X
10 Envelope 104.8 x 241.3 mm (4.12 x 9.5 in.)	✓	X	X	X	X	X	X
B5 Envelope 176 x 250 mm (6.93 x 9.84 in.)	✓ ²	X	X	X	X	X	X
C5 Envelope 162 x 229 mm (6.38 x 9.01 in.)	✓ ¹	X	X	X	X	X	X

¹ Loads only in short-edge orientation.

² Loads only in long-edge orientation.

³ Supports paper sizes ranging from 88.9 x 98.38 mm (3.5 x 3.87 in.) to 296.93 x 431.8 mm (11.69 x 17 in.).

⁴ Supports paper sizes ranging from 190 x 139.7 mm (7.48 x 5.5 in.) to 296.93 x 431.8 mm (11.69 x 17 in.).

⁵ Supports paper sizes ranging from 202.9 x 182.03 mm (7.99 x 7.17 in.) to 296.93 x 431.8 mm (11.69 x 17 in.).

⁶ Supports only up to two-hole punching.

⁷ Supports only up to two-hole punching when loaded in short-edge orientation.

⁸ Supports paper sizes ranging from 88.9 x 98.38 mm (3.5 x 3.87 in.) to 320.04 x 1320.8 mm (12.6 x 52 in.).

⁹ Supports paper sizes ranging from 209.97 x 148 mm (8.27 x 5.83 in.) to 296.93 x 431.8 mm (11.69 x 17 in.).

Paper size	Staple finisher			Staple, hole punch finisher			
	Stack	Offset	Staple	Stack	Offset	Staple	Hole punch
DL Envelope 110 x 220 mm (4.33 x 8.66 in.)	✓	X	X	X	X	X	X
<p>¹ Loads only in short-edge orientation.</p> <p>² Loads only in long-edge orientation.</p> <p>³ Supports paper sizes ranging from 88.9 x 98.38 mm (3.5 x 3.87 in.) to 296.93 x 431.8 mm (11.69 x 17 in.).</p> <p>⁴ Supports paper sizes ranging from 190 x 139.7 mm (7.48 x 5.5 in.) to 296.93 x 431.8 mm (11.69 x 17 in.).</p> <p>⁵ Supports paper sizes ranging from 202.9 x 182.03 mm (7.99 x 7.17 in.) to 296.93 x 431.8 mm (11.69 x 17 in.).</p> <p>⁶ Supports only up to two-hole punching.</p> <p>⁷ Supports only up to two-hole punching when loaded in short-edge orientation.</p> <p>⁸ Supports paper sizes ranging from 88.9 x 98.38 mm (3.5 x 3.87 in.) to 320.04 x 1320.8 mm (12.6 x 52 in.).</p> <p>⁹ Supports paper sizes ranging from 209.97 x 148 mm (8.27 x 5.83 in.) to 296.93 x 431.8 mm (11.69 x 17 in.).</p>							

Paper sizes supported by the trifold/Z-fold finisher and the booklet finisher

Paper size	Trifold/Z-fold finisher		Booklet finisher				
	Trifold	Z-fold	Stack	Offset	Staple	Hole punch	Fold
A3 297 x 420 mm (11.69 x 16.54 in.)	X	X	✓ ¹	✓ ¹	X	✓ ¹	X
A4 210 x 297 mm (8.27 x 11.7 in.)	X	✓	✓	✓	X	✓	X
A5 148 x 210 mm (5.83 x 8.27 in.)	X	X	✓	X	X	✓ ³	X
A6 105 x 148 mm (4.13 x 5.83 in.)	X	X	✓ ¹	X	X	X	X
Arch B 304.8 x 457.2 mm (12 x 18 in.)	X	X	✓	X	X	X	X
<p>¹ Loads only in short-edge orientation.</p> <p>² Loads only in long-edge orientation.</p> <p>³ Supports only up to two-hole punching when loaded in long-edge orientation.</p> <p>⁴ Supports paper sizes ranging from 202.9 x 181.86 mm (7.99 x 7.16 in.) to 320.04 x 482.94 mm (12.6 x 19.01 in.).</p> <p>⁵ Supports paper sizes ranging from 202.9 x 181.86 mm (7.99 x 7.16 in.) to 296.93 x 431.8 mm (17 x 11.69 in.).</p>							

Paper size	Trifold/Z-fold finisher		Booklet finisher				
	Trifold	Z-fold	Stack	Offset	Staple	Hole punch	Fold
Banner Max width: 215.9 mm (8.5 in.) Max length: 1320.8 mm (52 in.)	X	X	√ ₁	X	X	X	X
Executive 184.2 x 266.7 mm (7.25 x 10.5 in.)	X	X	√	√ ₂	√ ₂	√ ₂	X
Folio 215.9 x 330.2 mm (8.5 x 13 in.)	X	X	√ ₁	√ ₁	X	√ ₁	X
Hagaki 100 x 148 mm (3.94 x 5.83 in.)	X	X	√ ₁	X	X	X	X
JIS B4 ¹ 257 x 364 mm (10.12 x 14.33 in.)	X	√	√ ₁	√ ₁	X	√ ₁	X
JIS B5 182 x 257 mm (7.17 x 10.1 in.)	X	X	√	√ ₂	X	√ ₂	X
Ledger ¹ 279.4 x 4431.8 mm (11 x 17 in.)	X	√	√ ₁	√ ₁	X	√ ₁	X
Legal ¹ 215.9 x 355.6 mm (8.5 x 14 in.)	X	X	√ ₁	√ ₁	X	√ ₁	X
Letter 215.9 x 279.4 mm (8.5 x 11 in.)	X	√ ₁	√	√	X	√	X
Oficio (Mexico) ¹ 215.9 x 340.4 mm (8.5 x 13.4 in.)	X	X	√ ₁	√ ₁	X	√ ₁	X

¹ Loads only in short-edge orientation.

² Loads only in long-edge orientation.

³ Supports only up to two-hole punching when loaded in long-edge orientation.

⁴ Supports paper sizes ranging from 202.9 x 181.86 mm (7.99 x 7.16 in.) to 320.04 x 482.94 mm (12.6 x 19.01 in.).

⁵ Supports paper sizes ranging from 202.9 x 181.86 mm (7.99 x 7.16 in.) to 296.93 x 431.8 mm (17 x 11.69 in.).

Paper size	Trifold/Z-fold finisher		Booklet finisher				
	Trifold	Z-fold	Stack	Offset	Staple	Hole punch	Fold
SRA3 320.04 x 449.58 mm (12.6 x 17.7 in.)	X	X	✓	X	X	X	X
Statement 139.7 x 215.9 mm (5.5 x 8.5 in.)	X	X	✓	X	X	X	X
Universal	X	X	✓ ⁴	✓ ⁵	✓ ⁵	X	X
7 3/4 Envelope 98.4 x 190.5 mm (3.875 x 7.5 in.)	X	X	X	X	X	X	X
9 Envelope 98.4 x 225.4 mm (3.875 x 8.9 in.)	X	X	X	X	X	X	X
10 Envelope 104.8 x 241.3 mm (4.12 x 9.5 in.)	X	X	X	X	X	X	X
B5 Envelope 176 x 250 mm (6.93 x 9.84 in.)	X	X	✓ ¹	X	X	X	X
C5 Envelope 162 x 229 mm (6.38 x 9.01 in.)	X	X	✓ ¹	X	X	X	X
DL Envelope 110 x 220 mm (4.33 x 8.66 in.)	X	X	X	X	X	X	X

¹ Loads only in short-edge orientation.

² Loads only in long-edge orientation.

³ Supports only up to two-hole punching when loaded in long-edge orientation.

⁴ Supports paper sizes ranging from 202.9 x 181.86 mm (7.99 x 7.16 in.) to 320.04 x 482.94 mm (12.6 x 19.01 in.).

⁵ Supports paper sizes ranging from 202.9 x 181.86 mm (7.99 x 7.16 in.) to 296.93 x 431.8 mm (17 x 11.69 in.).

Supported paper types

Paper types supported by the standard tray, MPF, envelope tray, and two-sided printing

Paper type	Standard 2 x 520-sheet tray	Multipurpose feeder	Envelope tray	Two-sided printing
Bond	✓	✓	X	✓
Card Stock	✓	✓	X	✓
Colored Paper	✓	✓	X	✓
Custom Type	✓	✓	X	✓
Envelope	X	✓	✓	X
Glossy	✓	✓	X	✓
Heavy Glossy	✓	✓	X	✓
Heavy Paper	✓	✓	X	✓
Labels	✓	✓	X	X
Letterhead	✓	✓	X	✓
Light Paper	✓	✓	X	✓
Plain Paper	✓	✓	X	✓
Preprinted	✓	✓	X	✓
Recycled	✓	✓	X	✓
Rough Envelope	X	✓	✓	X
Rough Cotton	✓	✓	X	✓
Transparencies	X	X	X	X
Vinyl Labels	X	X	X	X

Paper types supported by the optional trays

Paper type	Optional 2 x 520-sheet tray	Optional 2000-sheet tandem tray	Optional 2000-sheet tray
Bond	✓	✓	✓
Card Stock	✓	✓	✓
Colored Paper	✓	✓	✓
Custom Type	✓	✓	✓
Envelope	X	X	X

Paper type	Optional 2 x 520-sheet tray	Optional 2000-sheet tandem tray	Optional 2000-sheet tray
Glossy	✓	✓	✓
Heavy Glossy	✓	✓	✓
Heavy Paper	✓	✓	✓
Labels	✓	✓	✓
Letterhead	✓	✓	✓
Light Paper	✓	✓	✓
Plain Paper	✓	✓	✓
Preprinted	✓	✓	✓
Recycled	✓	✓	✓
Rough Envelope	X	X	X
Rough Cotton	✓	✓	✓
Transparencies	X	X	X
Vinyl Labels	X	X	X

Paper types supported by the output bins

Paper type	Standard bin		Dual catch bin
	Stack	Offset	Stack
Bond	✓	✓	✓
Card Stock	✓	✓	✓
Colored Paper	✓	✓	✓
Custom Type	✓	✓	✓
Envelope	✓	✓	✓
Glossy	✓	✓	✓
Heavy Glossy	✓	✓	✓
Heavy Paper	✓	✓	✓
Labels	✓	✓	✓
Letterhead	✓	✓	✓
Light Paper	✓	✓	✓
Plain Paper	✓	✓	✓

Paper type	Standard bin		Dual catch bin
	Stack	Offset	Stack
Preprinted	✓	✓	✓
Recycled	✓	✓	✓
Rough Envelope	✓	✓	✓
Rough Cotton	✓	✓	✓
Transparencies	X	X	X
Vinyl Labels	X	X	X

Paper types supported by the staple finisher and the staple, hole punch finisher

Paper type	Staple finisher			Staple, hole punch finisher			
	Stack	Offset	Staple	Stack	Offset	Staple	Hole punch
Bond	✓	✓	✓	✓	✓	✓	✓
Card Stock	✓	✓	X	✓	✓	X	✓
Colored Paper	✓	✓	✓	✓	✓	✓	✓
Custom Type	✓	✓	✓	✓	✓	✓	✓
Envelope	✓	X	X	X	X	X	X
Glossy	✓	✓	✓	✓	✓	✓	✓
Heavy Glossy	✓	✓	X	✓	✓	X	✓
Heavy Paper	✓	✓	X	✓	✓	X	✓
Labels	✓	✓	X	X	X	X	X
Letterhead	✓	✓	✓	✓	✓	✓	✓
Light Paper	✓	✓	✓	✓	✓	✓	✓
Plain Paper	✓	✓	✓	✓	✓	✓	✓
Preprinted	✓	✓	✓	✓	✓	✓	✓
Recycled	✓	✓	✓	✓	✓	✓	✓
Rough Envelope	✓	X	X	X	X	X	X
Rough Cotton	✓	✓	X	✓	✓	X	✓
Transparencies	X	X	X	X	X	X	X
Vinyl Labels	X	X	X	X	X	X	X

Paper types supported by the trifold/Z-fold finisher and the booklet finisher

Paper type	Trifold/Z-fold finisher		Booklet finisher				
	Trifold	Z-fold	Stack	Offset	Staple	Hole punch	Fold
Bond	✓	X	✓	✓	✓	✓	X
Card Stock	X	X	✓	✓	X	✓	X
Colored Paper	✓	✓	✓	✓	✓	✓	✓
Custom Type	✓	✓	✓	✓	✓	✓	✓
Envelope	X	X	X	X	X	X	X
Glossy	✓	X	✓	✓	✓	✓	✓
Heavy Glossy	X	X	✓	✓	X	✓	X
Heavy Paper	X	X	✓	✓	X	✓	X
Labels	X	X	X	X	X	X	X
Letterhead	X	X	✓	✓	✓	✓	✓
Light Paper	✓	✓	✓	✓	✓	✓	✓
Plain Paper	✓	✓	✓	✓	✓	✓	✓
Preprinted	✓	✓	✓	✓	X	✓	X
Recycled	✓	✓	✓	✓	✓	✓	✓
Rough Envelope	X	X	X	X	X	X	X
Rough Cotton	X	X	✓	✓	X	✓	X
Transparencies	X	X	X	X	X	X	X
Vinyl Labels	X	X	X	X	X	X	X

Notes:

- Labels, envelopes, and card stock always print at reduced speed.
- Card stock is supported in two-sided printing only up to 163 g/m² (90-lb bond). Anything heavier is supported only in one-sided printing.
- Vinyl labels are supported for occasional use only and must be tested for acceptability. Some vinyl labels may feed more reliably from the multipurpose feeder.

Supported paper weights

Standard or optional 2 x 520-sheet tray, and optional 2000-sheet tandem tray	Multipurpose feeder	Envelope tray	Optional 2000-sheet tray
60–256 g/m ² (12–68-lb bond)	60–216 g/m ² (12–57-lb bond)	75–90 g/m ² (20–24-lb bond)	60–216 g/m ² (12–57-lb bond)

Notes:

- For 60–176 g/m² (16–47-lb bond) paper, grain long fibers are recommended.
- Paper less than 75 g/m² (20-lb bond) must be printed with Paper Type set to Light Paper. Failure to do so may cause excessive curl which can lead to feeding errors, especially in more humid environments.
- Two-sided printing supports paper weight from 60–162 g/m² (16–43-lb bond) paper.
- 100% cotton content maximum weight is 90 g/m² (24-lb bond).

Set up, install, and configure

Selecting a location for the printer

- Leave enough room to open trays, covers, and doors and to install hardware options.
- Set up the printer near an electrical outlet.

⚠ CAUTION—POTENTIAL INJURY: To avoid the risk of fire or electrical shock, connect the power cord to an appropriately rated and properly grounded electrical outlet that is near the product and easily accessible.

⚡ CAUTION—SHOCK HAZARD: To avoid the risk of electrical shock, do not place or use this product near water or wet locations.

- Make sure that airflow in the room meets the latest revision of the ASHRAE 62 standard or the CEN Technical Committee 156 standard.
- Provide a flat, sturdy, and stable surface.
- Keep the printer:
 - Clean, dry, and free of dust.
 - Away from stray staples and paper clips.
 - Away from the direct airflow of air conditioners, heaters, or ventilators.
 - Free from direct sunlight and humidity extremes.
- Observe the recommended temperatures and avoid fluctuations:

Ambient temperature	10 to 32.2°C (50 to 90°F)
Storage temperature	15.6 to 32.2°C (60 to 90°F)

- Allow the following recommended amount of space around the printer for proper ventilation:

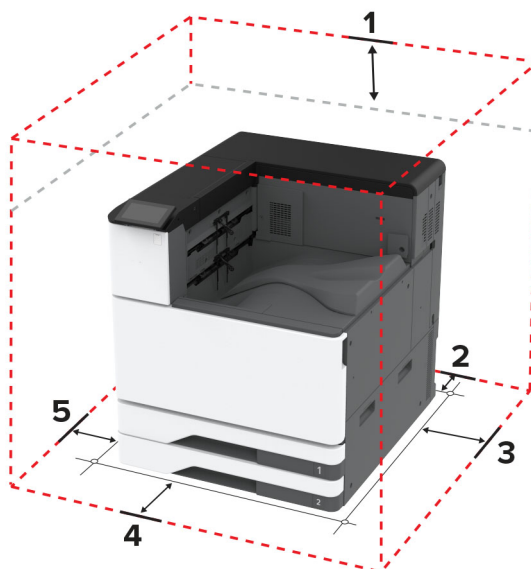

1	Top	150 mm (5.9 in.)
2	Rear	120 mm (4.8 in.)

3	Right side	400 mm (15.7 in.)
4	Front	444.5 mm (17.5 in.)
5	Left side	120 mm (4.8 in.)

Attaching cables

⚠ CAUTION—SHOCK HAZARD: To avoid the risk of electrical shock, do not set up this product or make any electrical or cabling connections, such as the power cord, fax feature, or telephone, during a lightning storm.

⚠ CAUTION—POTENTIAL INJURY: To avoid the risk of fire or electrical shock, connect the power cord to an appropriately rated and properly grounded electrical outlet that is near the product and easily accessible.

⚠ CAUTION—POTENTIAL INJURY: To avoid the risk of fire or electrical shock, use only the power cord provided with this product or the manufacturer's authorized replacement.

Warning—Potential Damage: To avoid loss of data or printer malfunction, do not touch the USB cable, any wireless network adapter, or the printer in the areas shown while actively printing.

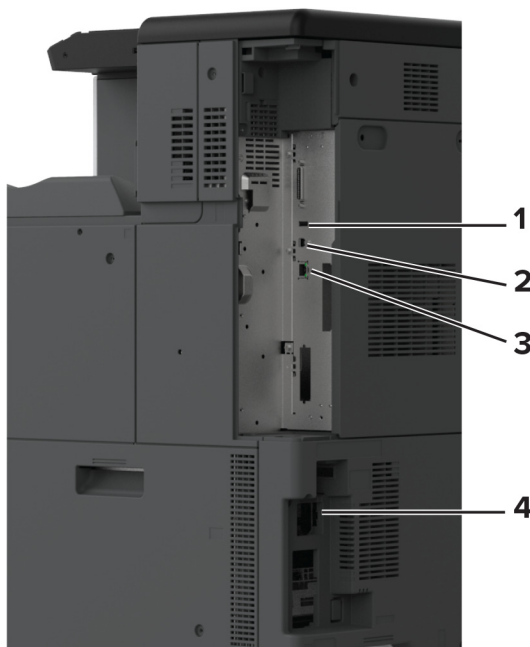

	Printer port	Function
1	USB port	Attach a keyboard or any compatible option.
2	USB printer port	Connect the printer to a computer.
3	Ethernet port	Connect the printer to a network.
4	Power cord socket	Connect the printer to a properly grounded electrical outlet.

Setting up and using the home screen applications

Using the home screen

Note: Your home screen may vary depending on your home screen customization settings, administrative setup, and active embedded solutions.



	Icon	Function
1	Stop or Cancel button	Stop the current printer task.
2	Status/Supplies	<ul style="list-style-type: none"> Show a warning or error message whenever the printer requires intervention to continue processing. View more information on the printer warning or message and how to clear it. <p>Note: You can also access this setting by touching the top section of the home screen.</p>
3	Job Queue	Show all the current print jobs. Note: You can also access this setting by touching the top section of the home screen.
4	Change Language	Change the language on the display.
5	Settings	Access the printer menus.
6	USB Drive	Print photos and documents from a flash drive.
7	Held Jobs	Show the print jobs that are held in the printer memory.
8	Address Book	Manage a contact list that other applications on the printer can access.
9	On-screen keypad	Enter numbers or symbols in an input field.

Customizing the home screen

- 1 Open a web browser, and then type the printer IP address in the address field.

Notes:

- View the printer IP address on the printer home screen. The IP address appears as four sets of numbers separated by periods, such as 123.123.123.123.

- If you are using a proxy server, then temporarily disable it to load the web page correctly.

2 Click **Settings > Device > Home Screen Customization**.

3 Do one or more of the following:

- To add an icon to the home screen, click **+**, select the app name, and then click **Add**.
- To remove a home screen icon, select the app name, and then click **Remove**.
- To customize an app name, select the app name, click **Edit**, and then assign a name.
- To restore the name of an app, select the app name, click **Edit**, and then select **Restore app label**.
- To add a space between apps, click **+**, select **BLANK SPACE**, and then click **Add**.
- To arrange the apps, drag the app names in the order that you want.
- To restore the default home screen, click **Restore home screen**.

4 Apply the changes.

Supported applications

- Display Customization
- Customer Support
- Device Quotas

Using Display Customization

Before using the application, make sure to do the following:

- From the Embedded Web Server, click **Apps > Display Customization > Configure**.
- Enable and configure the screen saver, slideshow, and wallpaper settings.

Managing screen saver and slide show images

1 From the Screen Saver and Slideshow Images section, add, edit, or delete an image.

Notes:

- You can add up to 10 images.
- When enabled, the status icons appear on the screen saver only when there are errors, warnings, or cloud-based notifications.

2 Apply the changes.

Changing the wallpaper image

1 From the home screen, touch **Change Wallpaper**.

2 Select an image to use.

3 Apply the changes.

Running a slide show from a flash drive

1 Insert a flash drive into the USB port.

2 From the home screen, touch **Slideshow**.

Images appear in alphabetical order.

Note: You can remove the flash drive after the slide show starts, but the images are not stored in the printer. If the slide show stops, then insert the flash drive again to view the images.

Using Customer Support

Notes:

- This application is supported only in some printer models. For more information, see [“Supported applications” on page 36](#).
- For information on how to configure the application settings, see the *Customer Support Administrator’s Guide*.

1 From the home screen, touch **Customer Support**.

2 Print or e-mail the information.

Setting up Device Quotas

Notes:

- This application is supported only in some printer models. For more information, see [“Supported applications” on page 36](#).
- For information on how to configure the application settings, see the *Device Quotas Administrator’s Guide*.

1 Open a web browser, and then type the printer IP address in the address field.

Notes:

- View the printer IP address on the printer home screen. The IP address appears as four sets of numbers separated by periods, such as 123.123.123.123.
- If you are using a proxy server, then temporarily disable it to load the web page correctly.

2 Click **Apps > Device Quotas > Configure**.

3 In the User Accounts section, add or edit a user, and then set the user quota.

4 Apply the changes.

Managing bookmarks

Creating bookmarks

Use bookmarks to print frequently accessed documents that are stored in servers or on the web.

1 Open a web browser, and then type the printer IP address in the address field.

Notes:

- View the printer IP address on the printer home screen. The IP address appears as four sets of numbers separated by periods, such as 123.123.123.123.
- If you are using a proxy server, then temporarily disable it to load the web page correctly.

2 Click **Bookmarks > Add Bookmark**, and then type a bookmark name.

- 3 Select an Address protocol type, and then do one of the following:
 - For HTTP and HTTPS, type the URL that you want to bookmark.
 - For HTTPS, make sure to use the host name instead of the IP address. For example, type **myWebsite.com/sample.pdf** instead of typing **123.123.123.123/sample.pdf**. Make sure that the host name also matches the Common Name (CN) value in the server certificate. For more information on obtaining the CN value in the server certificate, see the help information for your web browser.
 - For FTP, type the FTP address. For example, **myServer/myDirectory**. Enter the FTP port number. Port 21 is the default port for sending commands.
 - For SMB, type the network folder address. For example, **myServer/myShare/myFile.pdf**. Type the network domain name.
 - If necessary, select the Authentication type for FTP and SMB.

To limit access to the bookmark, enter a PIN.

Note: The application supports the following file types: PDF, JPEG, and TIFF. Other file types such as DOCX and XLSX are supported in some printer models.

- 4 Click **Save**.

Creating folders

- 1 Open a web browser, and then type the printer IP address in the address field.

Notes:

- View the printer IP address on the printer home screen. The IP address appears as four sets of numbers separated by periods, such as 123.123.123.123.
- If you are using a proxy server, then temporarily disable it to load the web page correctly.





- 2 Click **Bookmarks > Add Folder**, and then type a folder name.

Note: To limit access to the folder, enter a PIN.

- 3 Click **Save**.

Note: You can create folders or bookmarks inside a folder. To create a bookmark, see [“Creating bookmarks” on page 37](#).

Managing contacts

- 1 From the home screen, touch **Address Book**.
- 2 Do one or more of the following:
 - To add a contact, touch  on top of the screen, and then touch **Create Contact**. If necessary, specify a login method to allow application access.
 - To delete a contact, touch  on top of the screen, touch **Delete Contacts**, and then select the contact.
 - To edit contact information, touch the contact name.
 - To create a group, touch  on top of the screen, and then touch **Create Group**. If necessary, specify a login method to allow application access.
 - To delete a group, touch  on top of the screen, touch **Delete Groups**, and then select the group.
 - To edit a contact group, touch **GROUPS >** select a group name **>**  **>** select the action you want to make.
- 3 Apply the changes.

Setting up and using the accessibility features

Activating Voice Guidance

From the home screen

- 1 In one motion and using one finger, slowly swipe left then up on the display until you hear a voice message.
- 2 Using two fingers, touch **OK**.

Note: If the gesture does not work, then apply more pressure.

From the keyboard

- 1 Press and hold the **5** key until you hear a voice message.
- 2 Press **Tab** to navigate the focus cursor to the OK button, and then press **Enter**.

Notes:

- When Voice Guidance is activated, always use two fingers to select any item on the display.
- Voice Guidance has limited language support.

Deactivating Voice Guidance

- 1 In one motion and using one finger, slowly swipe left then up on the display until you hear a voice message.
- 2 Using two fingers, do either of the following:
 - Touch **Voice Guidance**, then touch **OK**.
 - Touch **Cancel**.

Note: If the gesture does not work, then apply more pressure.

You can also deactivate Voice Guidance by doing either of the following:

- Using two fingers, double tap the home screen.
- Press the power button to put the printer in Sleep or Hibernate mode.

Navigating the screen using gestures

Notes:

- Most of the gestures are applicable only when Voice Guidance is activated.
- Enable Magnification to use the zoom and pan gestures.
- Use a physical keyboard to type characters and adjust certain settings.

Gesture	Function
Swipe left then up using one finger	Launch Accessibility mode. Use the same gesture to exit Accessibility mode. Note: This gesture is also applicable when the printer is in normal mode.
Double-tap using one finger	Select an option or item on the screen.

Gesture	Function
Double-tap the home icon using two fingers	Deactivate the Accessibility mode.
Triple-tap using one finger	Zoom in or zoom out text and images.
Swipe right or swipe down using one finger	Move to the next item on the screen.
Swipe left or swipe up using one finger	Move to the previous item on the screen.
Swipe up then down using one finger	Move to the first item on the screen.
Pan	Access parts of the zoomed image that are beyond the limit of the screen. Note: Use two fingers to drag a zoomed image.
Swipe up then right using one finger	Increase the volume. Note: This gesture is also applicable when the printer is in normal mode.
Swipe down then right using one finger	Decrease the volume. Note: This gesture is also applicable when the printer is in normal mode.
Swipe up then left using one finger	Exit an application and return to the home screen.
Swipe down then left using one finger	Go back to the previous setting.

Using the on-screen keyboard

When the on-screen keyboard appears, do one or more of the following:

- Touch a key to announce and type the character in the field.
- Drag a finger across different characters to announce and type the character in the field.
- Touch a text box using two fingers to announce the characters in the field.
- Touch **Backspace** to delete characters.

Enabling Magnification mode

1 In one motion and using one finger, slowly swipe left then up on the display until you hear a voice message.

Note: For printer models without built-in speakers, use headphones to hear the message.

2 Using two fingers, do the following:

- a Touch **Magnification mode**.
- b Touch **OK**.

Note: If the gesture does not work, then apply more pressure.

For more information on navigating a magnified screen, see [“Navigating the screen using gestures” on page 39](#).

Adjusting the Voice Guidance speech rate

- 1 From the home screen, touch **Settings** > **Device** > **Accessibility** > **Speech Rate**.
- 2 Select the speech rate.

Adjusting the default headphone volume

- 1 From the home screen, touch **Settings** > **Device** > **Accessibility**.
- 2 Adjust the headphone volume.

Note: The volume resets to the default value after the user exits Accessibility mode or when the printer wakes from Sleep or Hibernate mode.

Adjusting the default internal speaker volume

- 1 From the home screen, touch .
- 2 Adjust the volume.

Notes:

- If Quiet Mode is enabled, then audible alerts are turned off. This setting also slows the printer performance.
- The volume resets to the default value after the user exits Accessibility mode or when the printer wakes from Sleep or Hibernate mode.

Enabling spoken passwords or personal identification numbers

- 1 From the home screen, touch **Settings** > **Device** > **Accessibility** > **Speak Passwords/PINs**.
- 2 Enable the setting.

Loading paper and specialty media

Setting the size and type of the specialty media

The trays automatically detect the size of plain paper. For specialty media like labels, card stock, or envelopes, do the following:

- 1 From the home screen, touch **Settings** > **Paper** > **Tray Configuration** > **Paper Size/Type** > select a paper source.
- 2 Set the size and type of the specialty media.

Configuring Universal paper settings

- 1 From the home screen, touch **Settings** > **Paper** > **Media Configuration** > **Universal Setup**.
- 2 Configure the settings.

Enabling the Multiple Universal Sizes setting

- 1 From the home screen, touch **Settings** > **Device** > **Maintenance** > **Configuration Menu** > **Tray Configuration**.
- 2 Enable the Multiple Universal Sizes setting.

Loading the 520-sheet tray

CAUTION—TIPPING HAZARD: To reduce the risk of equipment instability, load each tray separately. Keep all other trays closed until needed.

- 1 Pull out the tray.

Note: To avoid jams, do not pull out trays while the printer is busy.

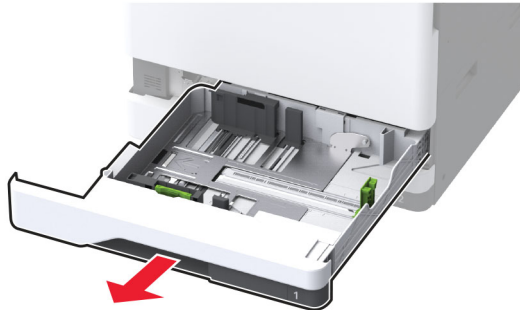

- 2 Adjust the guides to match the size of the paper that you are loading.

Note: Use the indicators on the bottom of the tray to position the guides.

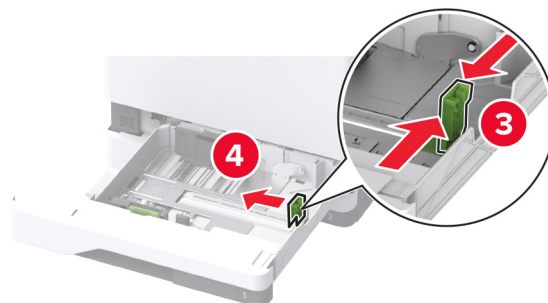
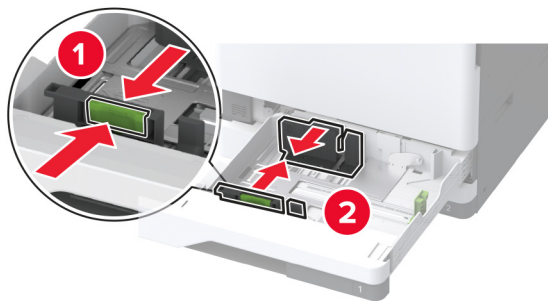

- 3** Flex, fan, and align the paper edges before loading.

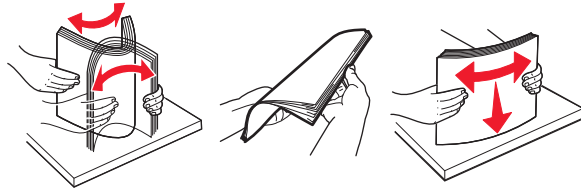

- 4** Load the paper stack with the printable side faceup.

When loading letterhead or prepunched paper, do either of the following:

For one-sided, long-edge printing

- Load letterhead faceup with the header toward the back of the tray.

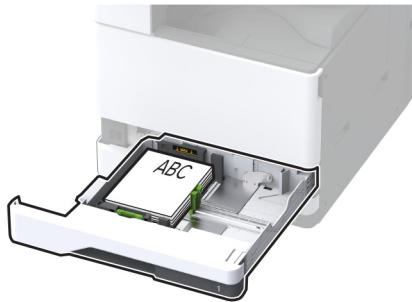

- Load prepunched paper faceup with the holes against the left side of the tray.



For one-sided, short-edge printing

- Load letterhead faceup with the header toward the left side of the tray.

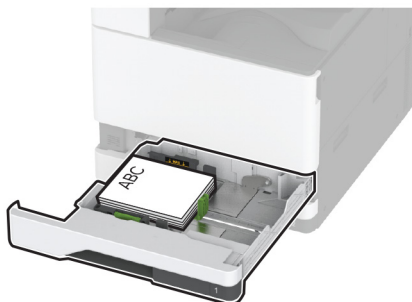

- Load prepunched paper faceup with the holes against the front of the tray.

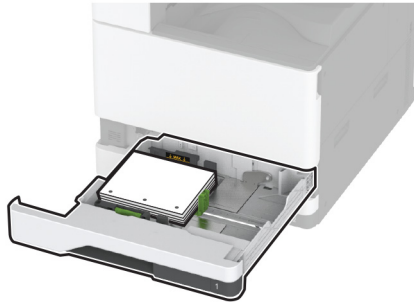

For two-sided, long-edge printing

- Load letterhead facedown with the header toward the back of the tray.



- Load prepunched paper facedown with the holes against the right side of the tray.



For two-sided, short-edge printing

- Load letterhead facedown with the header toward the left side of the tray.

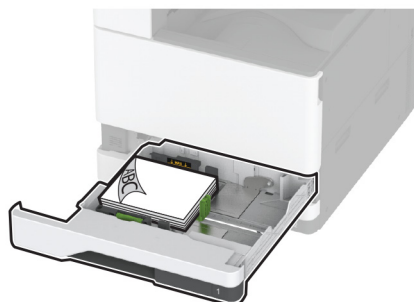

- Load prepunched paper facedown with the holes against the back of the tray.

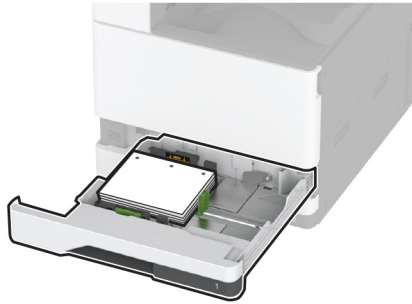
**Notes:**

- Do not slide paper into the tray.
- Make sure that the side guides fit snugly against the paper.
- Make sure that the stack height is below the maximum paper fill indicator. Overfilling may cause paper jams.

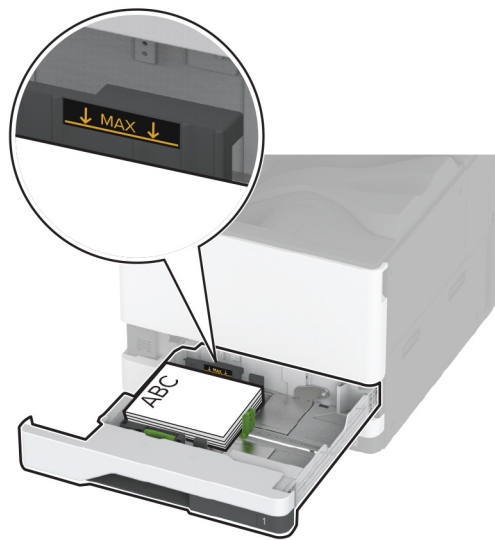
**5** Insert the tray.

If necessary, set the paper size and type to match the paper loaded in the tray.

Note: When a finisher is installed, the images are rotated to 180° when printed.

Loading the 2000-sheet tandem tray

 **CAUTION—TIPPING HAZARD:** To reduce the risk of equipment instability, load each tray separately. Keep all other trays closed until needed.

1 Pull out the tray.

Note: To avoid jams, do not pull out trays while the printer is busy.



2 Adjust the guides to match the size of the paper that you are loading.

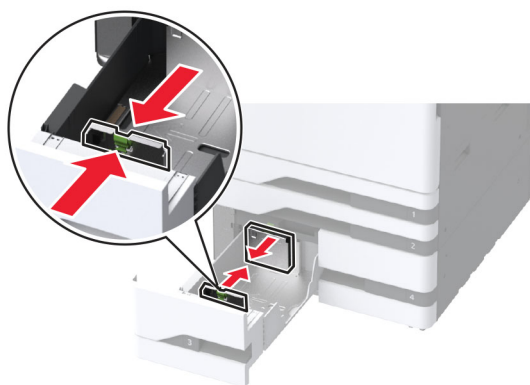

3 Flex, fan, and align the paper edges before loading.

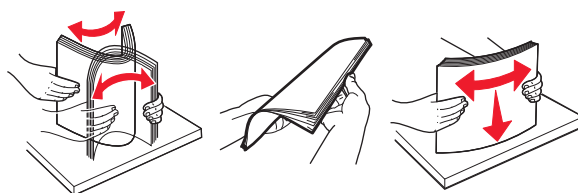

4 Load the paper stack with the printable side faceup.

When loading letterhead or prepunched paper, do either of the following:

For one-sided printing

- Load letterhead faceup with the header toward the back of the tray.



- Load prepunched paper faceup with the holes against the left side of the tray.



For two-sided printing

- Load letterhead facedown with the header toward the back of the tray.



- Load prepunched paper facedown with the holes against the right side of the tray.

**Notes:**

- Do not slide paper into the tray.
- Make sure that the stack height is below the maximum paper fill indicator. Overfilling may cause paper jams.



5 Insert the tray.

If necessary, set the paper size and type to match the paper loaded in the tray.

Note: When a finisher is installed, the images are rotated to 180° when printed.

Loading the 2000-sheet tray

CAUTION—TIPPING HAZARD: To reduce the risk of equipment instability, load each tray separately. Keep all other trays closed until needed.

1 Pull out the tray, and then open the tray side door.

Note: To avoid jams, do not pull out trays while the printer is busy.

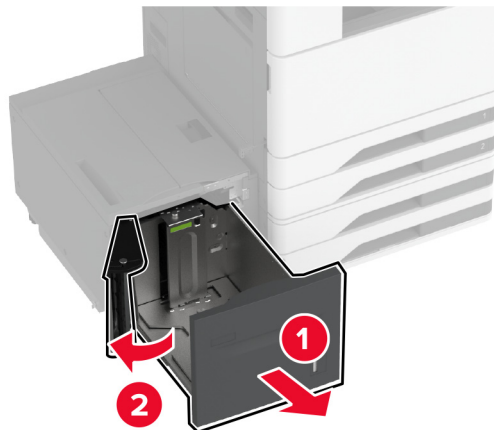

2 Adjust the guide at the back of the tray. Do the same at the front of the tray.

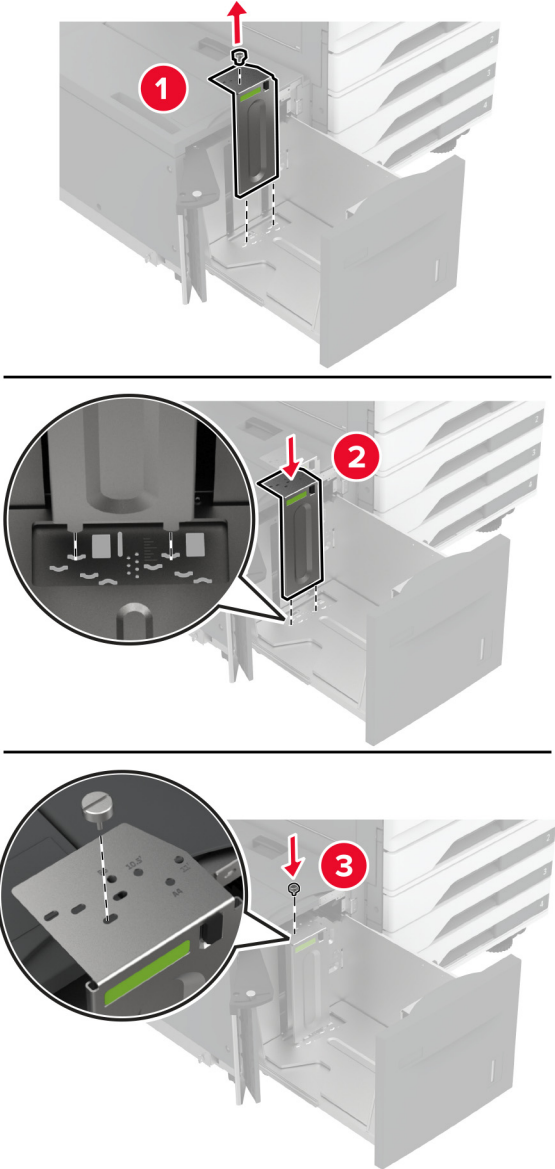

- 3** Adjust the lever on the tray side door.

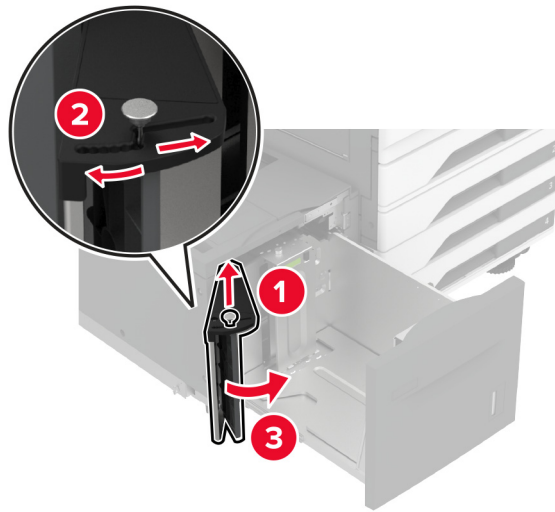

- 4** Flex, fan, and align the paper edges before loading.

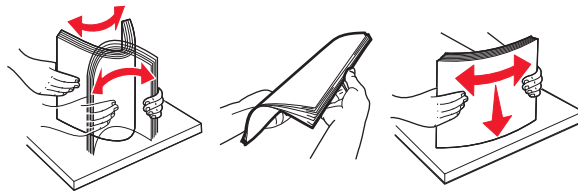

- 5** Load the paper stack with the printable side faceup.

When loading letterhead or prepunched paper, do either of the following:

For one-sided printing

- Load letterhead facedown with the header toward the back of the tray.

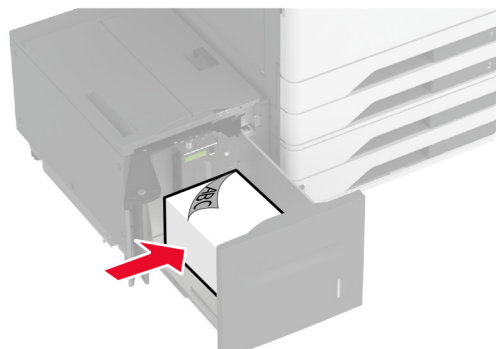

- Load prepunched paper facedown with the holes against the left side of the tray.

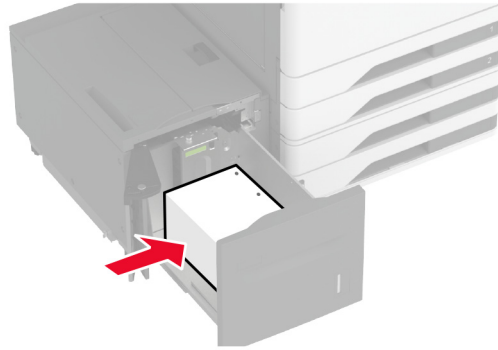

For two-sided printing

- Load letterhead faceup with the header toward the back of the tray.

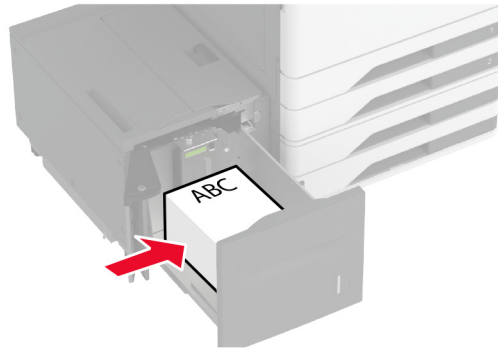

- Load prepunched paper faceup with the holes against the left side of the tray.

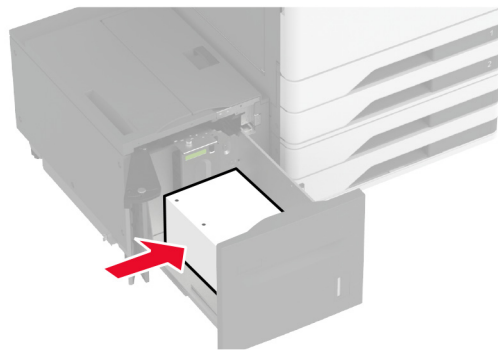

Note: Make sure that the stack height is below the maximum paper fill indicator. Overfilling may cause paper jams.

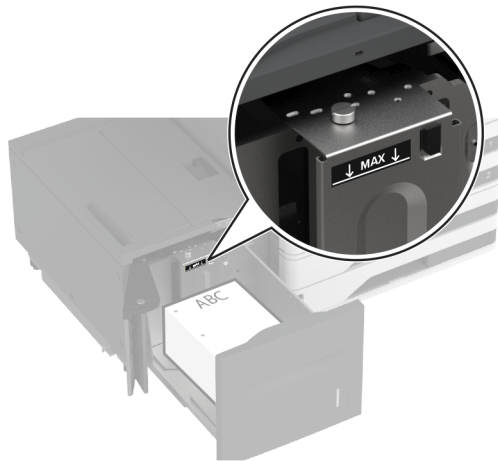

6 Close the tray side door, and then insert the tray.

If necessary, set the paper size and type to match the paper loaded in the tray.

Note: When a finisher is installed, the images are rotated to 180° when printed.

Loading the envelope tray



CAUTION—TIPPING HAZARD: To reduce the risk of equipment instability, load each tray separately. Keep all other trays closed until needed.

1 Pull out the envelope tray.

Note: To avoid jams, do not pull out trays while the printer is busy.

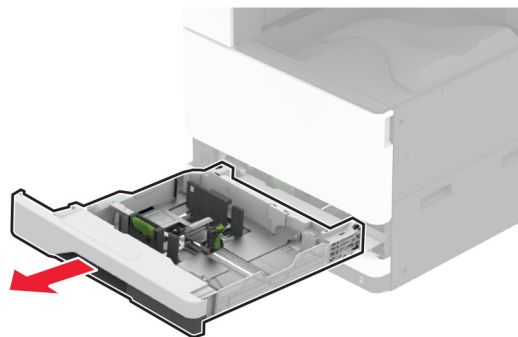

2 Flex, fan, and align the envelope edges before loading.

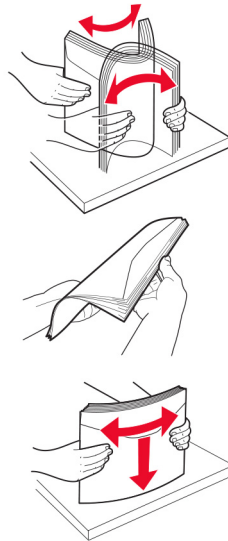

3 Adjust the guides to match the size of the envelope that you are loading.

Note: Use the indicators on the bottom of the tray to position the guides.

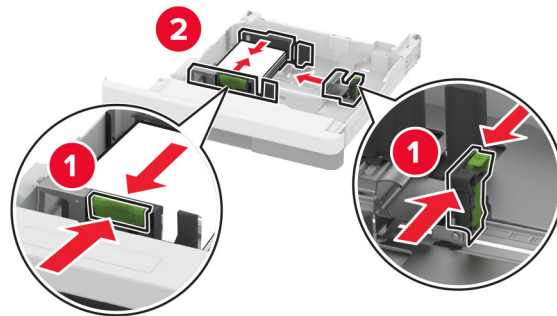

4 Load the envelopes with the flap side down and against the left side of the tray.

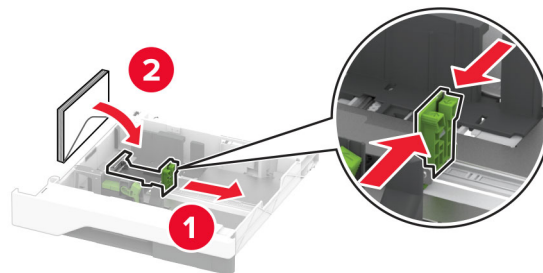

Notes:

- Make sure that the side guides fit snugly against the envelopes.
- Make sure that the stack height is below the maximum fill indicator. Overfilling may cause jams.

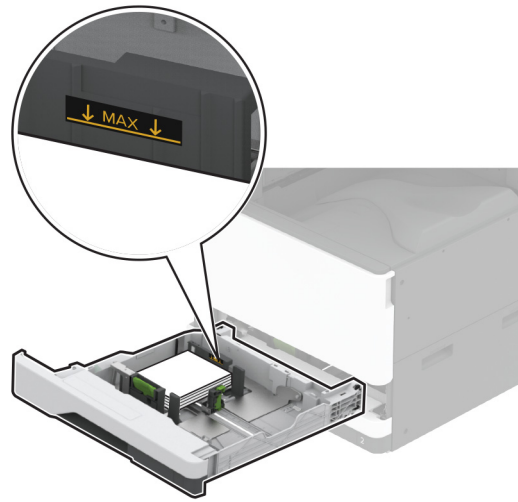

5 Insert the tray.

If necessary, set the paper size and paper type to match the envelope loaded in the tray.

Loading the multipurpose feeder

1 Open the multipurpose feeder.

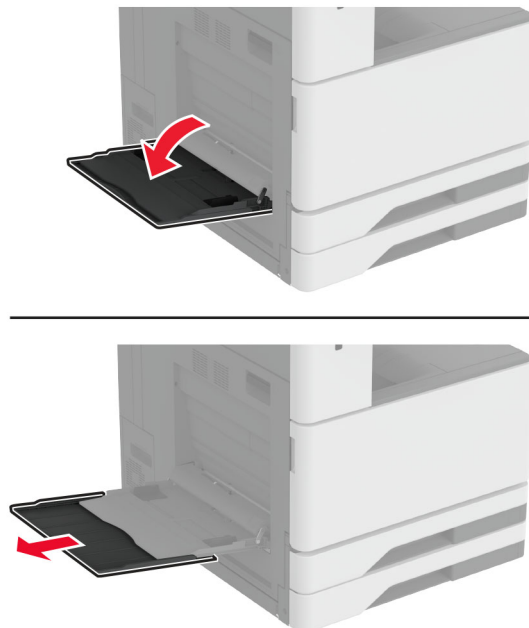

- 2 Adjust the side guides to match the size of the paper that you are loading.

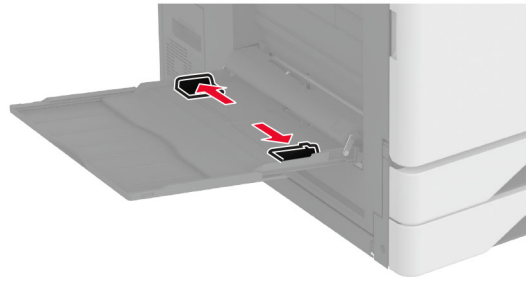

- 3 Flex, fan, and align the paper edges before loading.

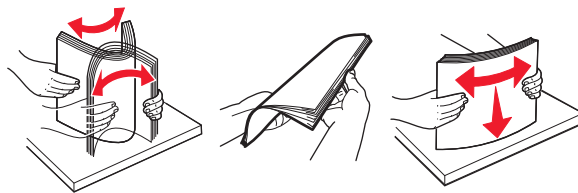

- 4 Load the paper.

Note: Make sure that the side guides fit snugly against the paper.

For long-edge feed:

- For one-sided printing, load letterhead facedown with the header toward the rear of the printer. Load prepunched paper facedown with the holes to the right side of the paper.

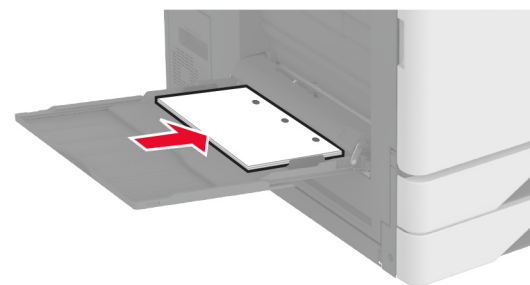
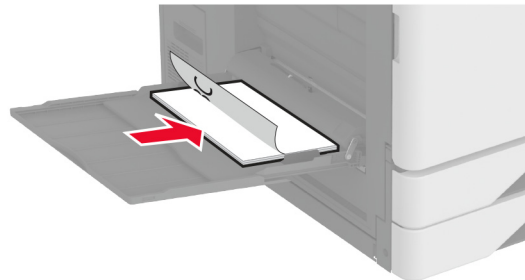

- For two-sided printing, load letterhead faceup with the header toward the rear of the printer. Load prepunched paper faceup with the holes to the left side of the paper.

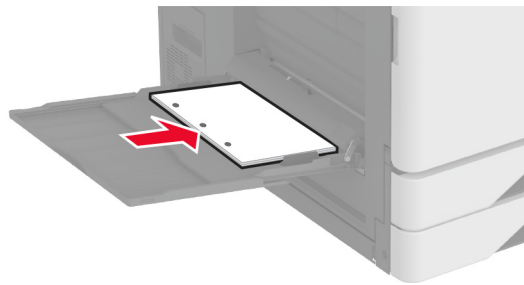
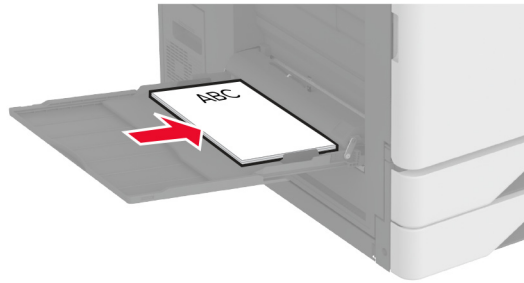
**For short-edge feed:**

- For one-sided printing, load letterhead facedown with the header to the left side of the paper. Load prepunched paper facedown with the holes toward the front of the printer.

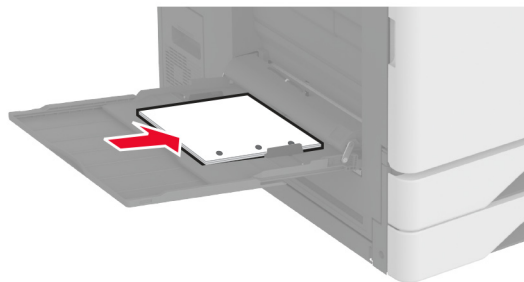
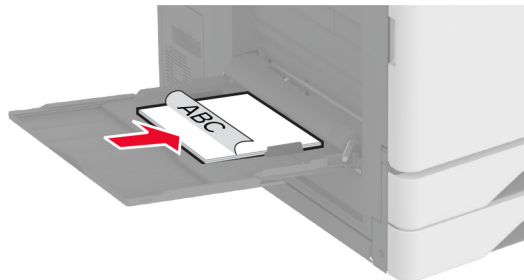

- For two-sided printing, load letterhead faceup with the header to the left side of the paper. Load prepunched paper faceup with the holes toward the back of the printer.

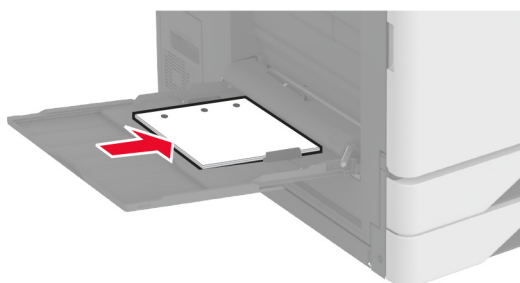
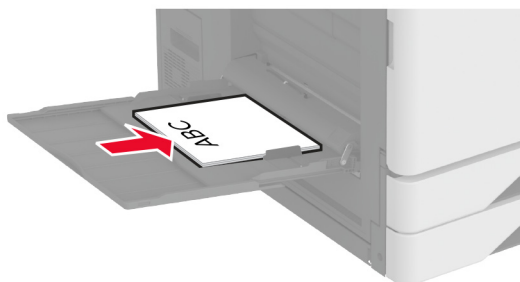

Note: When a finisher is installed, the printer rotates the images to 180°.

Linking trays

- 1 From the home screen, touch **Settings** > **Paper** > **Tray Configuration** > select a paper source.
- 2 Set the same paper size and paper type for the trays that you are linking.
- 3 From the home screen, touch **Settings** > **Device** > **Maintenance** > **Configuration Menu** > **Tray Configuration** > **Tray Linking**.
- 4 Touch **Automatic**.

To unlink trays, make sure that no trays have the same paper size and paper type settings.

Warning—Potential Damage: The temperature of the fuser varies according to the specified paper type. To avoid printing issues, match the paper type setting in the printer with the paper loaded in the tray.

Installing and updating software, drivers, and firmware

Installing the printer software

Notes:

- The print driver is included in the software installer package.

- For Macintosh computers with macOS version 10.7 or later, you do not need to install the driver to print on an AirPrint-certified printer. If you want custom printing features, then download the print driver.
- 1 Obtain a copy of the software installer package.
 - From the software CD that came with your printer.
 - Go to www.lexmark.com/downloads.
 - 2 Run the installer, and then follow the instructions on the computer screen.

Adding printers to a computer

Before you begin, do one of the following:

- Connect the printer and the computer to the same network. For more information on connecting the printer to a network, see [“Connecting the printer to a Wi-Fi network” on page 160](#).
- Connect the computer to the printer. For more information, see [“Connecting a computer to the printer” on page 162](#).
- Connect the printer to the computer using a USB cable. For more information, see [“Attaching cables” on page 34](#).

Note: The USB cable is sold separately.

For Windows users

- 1 From a computer, install the print driver.

Note: For more information, see [“Installing the printer software” on page 58](#).
- 2 Open **Printers & scanners**, and then click **Add a printer or scanner**.
- 3 Depending on your printer connection, do one of the following:
 - Select a printer from the list, and then click **Add device**.
 - Click **Show Wi-Fi Direct printers**, select a printer, and then click **Add device**.
 - Click **The printer that I want isn't listed**, and then from the Add Printer window, do the following:
 - a Select **Add a printer using a TCP/IP address or hostname**, and then click **Next**.
 - b In the “Hostname or IP address” field, type the printer IP address, and then click **Next**.

Notes:

- View the printer IP address on the printer home screen. The IP address appears as four sets of numbers separated by periods, such as 123.123.123.123.
 - If you are using a proxy server, then temporarily disable it to load the web page correctly.
- c Select a print driver, and then click **Next**.
 - d Select **Use the print driver that is currently installed (recommended)**, and then click **Next**.
 - e Type a printer name, and then click **Next**.
 - f Select a printer sharing option, and then click **Next**.
 - g Click **Finish**.

For Macintosh users

- 1 From a computer, open **Printers & Scanners**.
- 2 Click **+**, and then select a printer.

3 From the Use menu, select a print driver.

Notes:

- To use the Macintosh print driver, select either **AirPrint** or **Secure AirPrint**.
- If you want custom printing features, then select the Lexmark print driver. To install the driver, see [“Installing the printer software” on page 58](#).

4 Add the printer.

Updating firmware

To enhance printer performance and fix issues, update the printer firmware regularly.

For more information on updating the firmware, contact your Lexmark representative.

To get the latest firmware, go to www.lexmark.com/downloads, and then search for your printer model.

1 Open a web browser, and then type the printer IP address in the address field.

Notes:

- View the printer IP address on the printer home screen. The IP address appears as four sets of numbers separated by periods, such as 123.123.123.123.
- If you are using a proxy server, then temporarily disable it to load the web page correctly.

2 Click **Settings > Device > Update Firmware**.

3 Do either of the following:

- Click **Check for updates > I agree, start update**.
- Upload the flash file.
 - a Browse to the flash file.

Note: Make sure that you have extracted the firmware zip file.

b Click **Upload > Start**.

Exporting or importing a configuration file

You can export the configuration settings of your printer into a text file, and then import the file to apply the settings to other printers.

1 Open a web browser, and then type the printer IP address in the address field.

Notes:

- View the printer IP address on the printer home screen. The IP address appears as four sets of numbers separated by periods, such as 123.123.123.123.
- If you are using a proxy server, then temporarily disable it to load the web page correctly.

2 From the Embedded Web Server, click **Export Configuration** or **Import Configuration**.

3 Follow the instructions on the screen.

4 If the printer supports applications, then do the following:

- a Click **Apps > select the application > Configure**.
- b Click **Export** or **Import**.

Adding available options in the print driver

For Windows users

- 1 Open the printers folder.
- 2 Select the printer you want to update, and then do either of the following:
 - For Windows 7 or later, select **Printer properties**.
 - For earlier versions, select **Properties**.
- 3 Navigate to the Configuration tab, and then select **Update Now - Ask Printer**.
- 4 Apply the changes.

For Macintosh users

- 1 From System Preferences in the Apple menu, navigate to your printer, and then select **Options & Supplies**.
- 2 Navigate to the list of hardware options, and then add any installed options.
- 3 Apply the changes.

Installing hardware options

Installing the envelope tray

- 1 Remove tray 1.

Note: Do not throw away the standard tray.

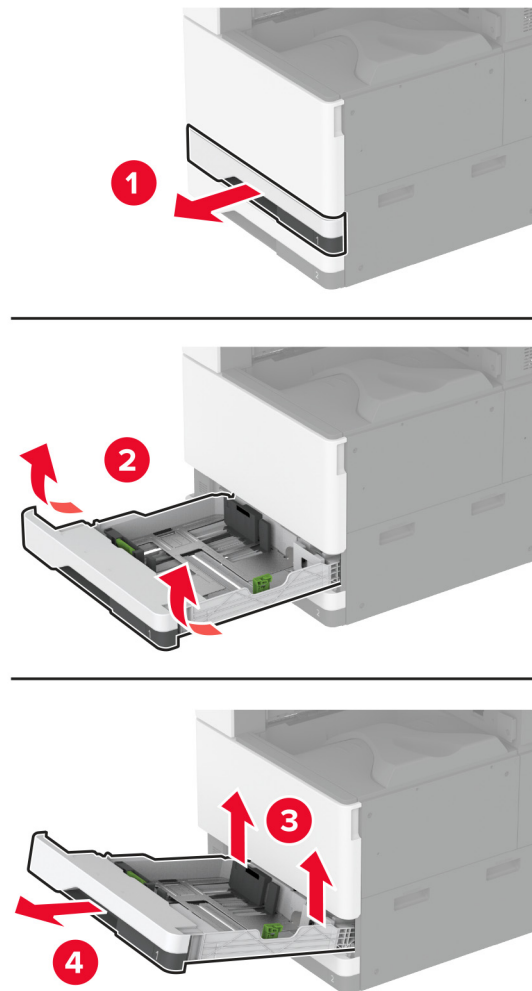

- 2 Unpack the envelope tray, and then remove all the packing material.
- 3 Insert the envelope tray.

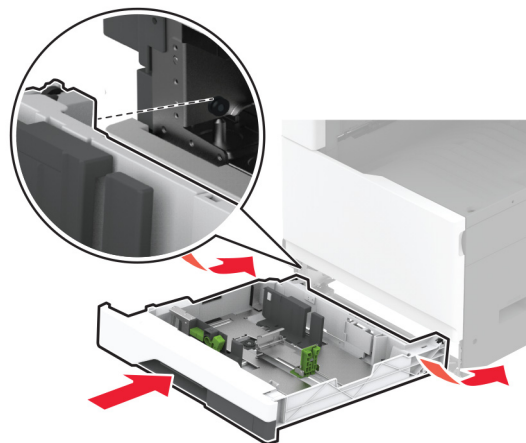

To make the envelope tray available for print jobs, from the home screen, touch **Settings > Device > Maintenance > Configuration Menu > Tray Configuration > Envelope Tray Setup > On.**

Installing the optional spacer

⚠ CAUTION—SHOCK HAZARD: To avoid the risk of electrical shock, if you are accessing the controller board or installing optional hardware or memory devices sometime after setting up the printer, then turn the printer off, and unplug the power cord from the electrical outlet before continuing. If you have any other devices attached to the printer, then turn them off as well, and unplug any cables going into the printer.

- 1 Turn off the printer.

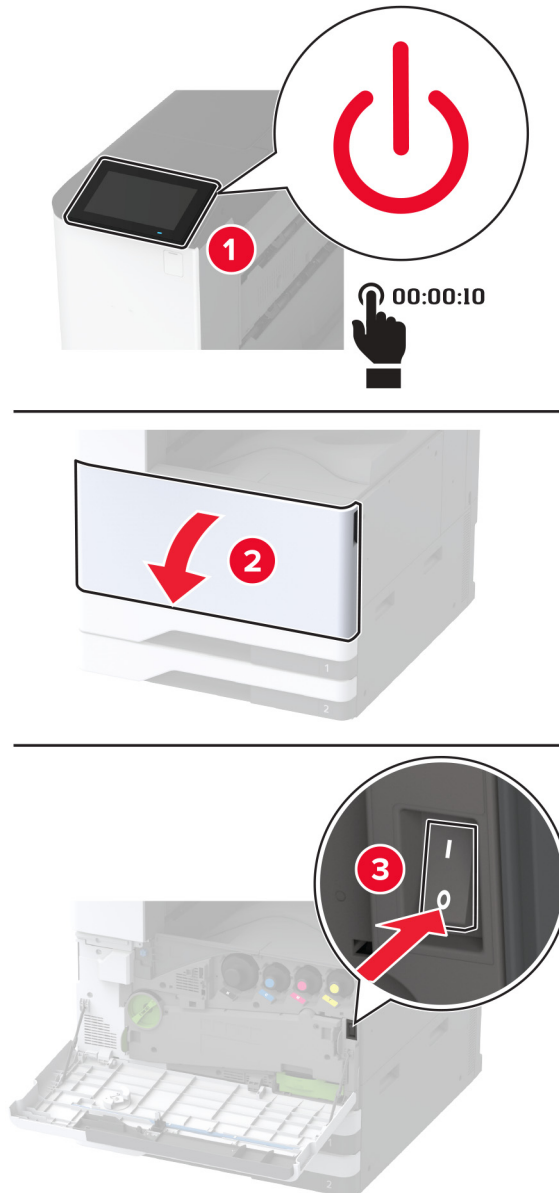

- 2 Unplug the power cord from the electrical outlet, and then from the printer.

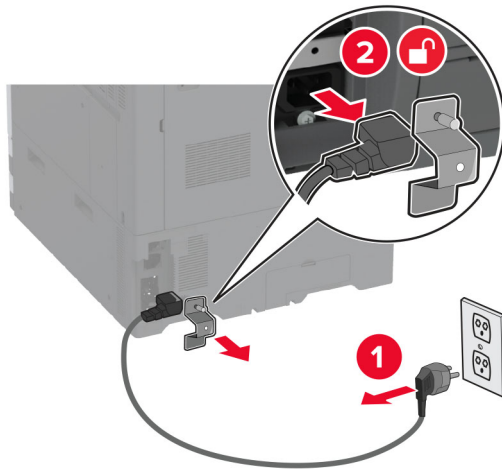

- 3 Unpack the optional spacer, and then remove all the packing material.
- 4 Lock the casters to keep the spacer from moving.

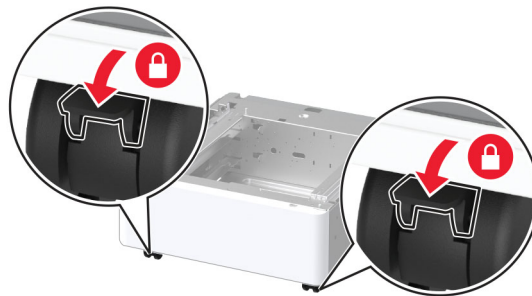

- 5 Remove the option installation cover under the left side of the printer.

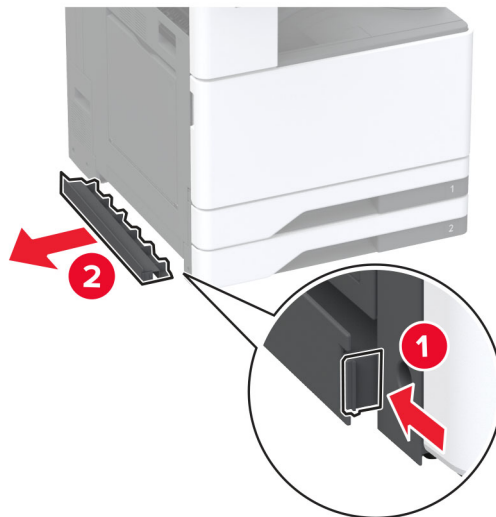

- 6 Pull out the lifting handle on the left side of the printer.

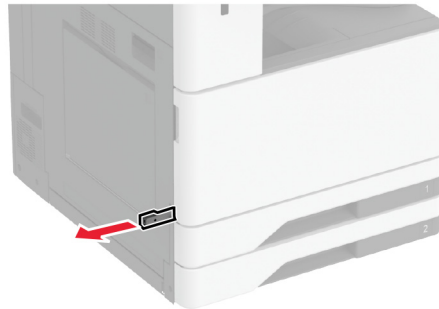

- 7 Align the printer with the spacer, and then lower the printer into place.

⚠ CAUTION—POTENTIAL INJURY: If the printer weight is greater than 20 kg (44 lb), then it may require two or more people to lift it safely.



8 Remove tray 2.

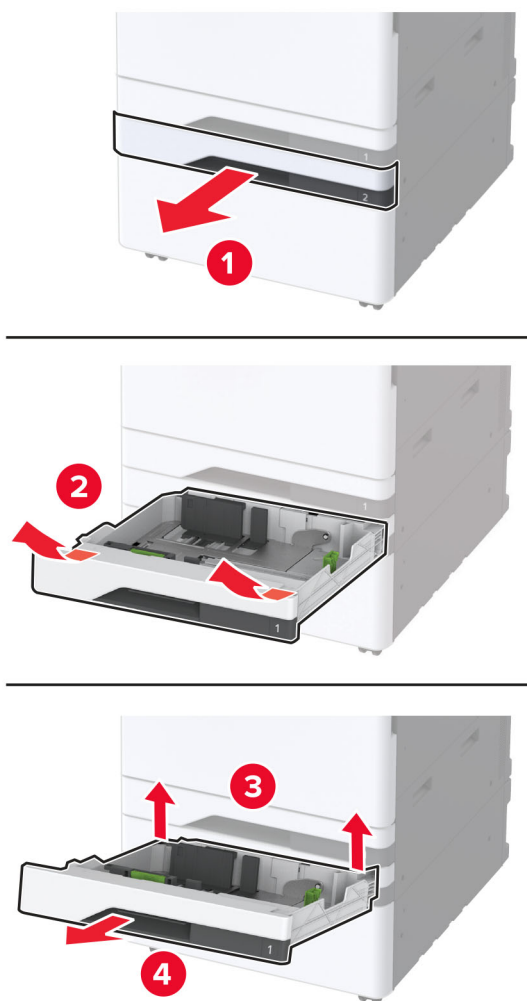

9 Secure the spacer to the printer with screws.

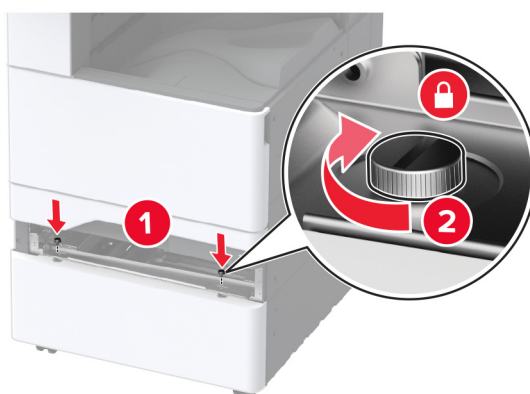

10 Insert tray 2.

11 Remove the connector cover from the rear of the printer.

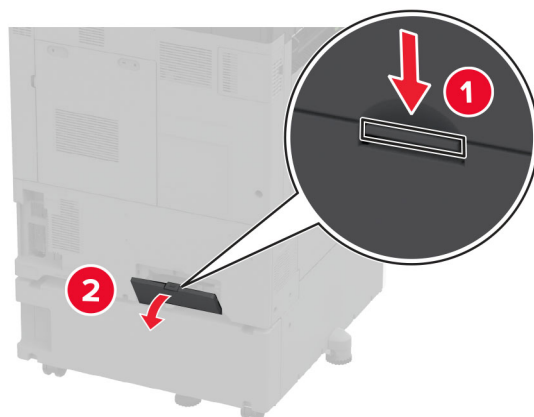

12 Secure the locking bracket to the printer, and then attach the cover.

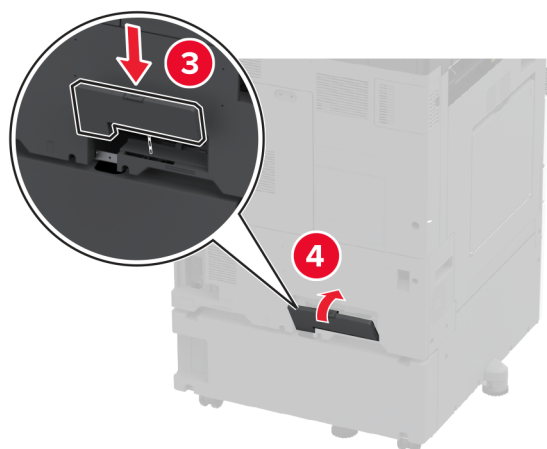
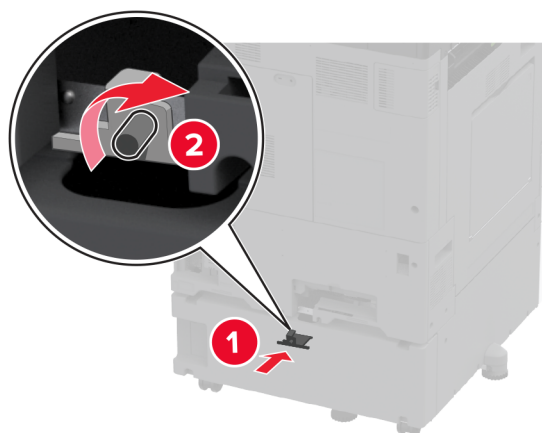

- 13** Adjust the levelers to make sure that all sides of the printer have the same height.

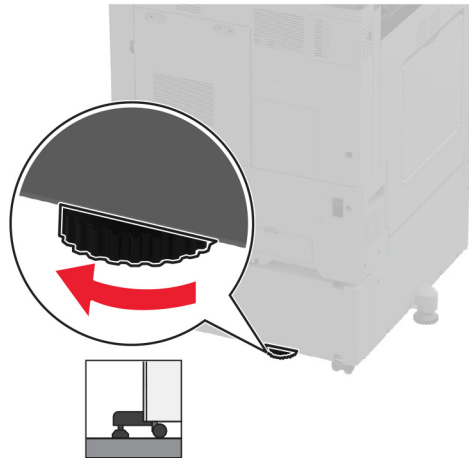
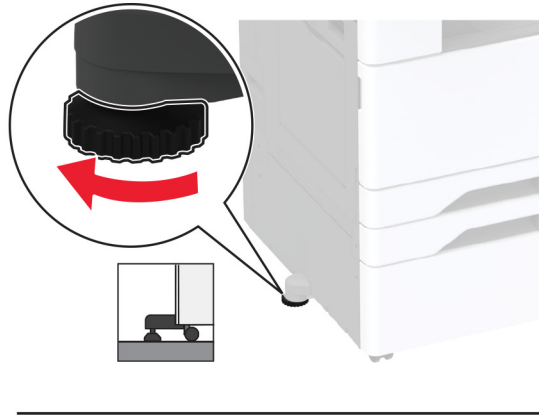

- 14** Connect the power cord to the printer, and then to the electrical outlet.

⚠ CAUTION—POTENTIAL INJURY: To avoid the risk of fire or electrical shock, connect the power cord to an appropriately rated and properly grounded electrical outlet that is near the product and easily accessible.

- 15** Turn on the printer.

Installing the optional 2 x 520-sheet tray

⚠ CAUTION—SHOCK HAZARD: To avoid the risk of electrical shock, if you are accessing the controller board or installing optional hardware or memory devices sometime after setting up the printer, then turn the printer off, and unplug the power cord from the electrical outlet before continuing. If you have any other devices attached to the printer, then turn them off as well, and unplug any cables going into the printer.

- 1 Turn off the printer.

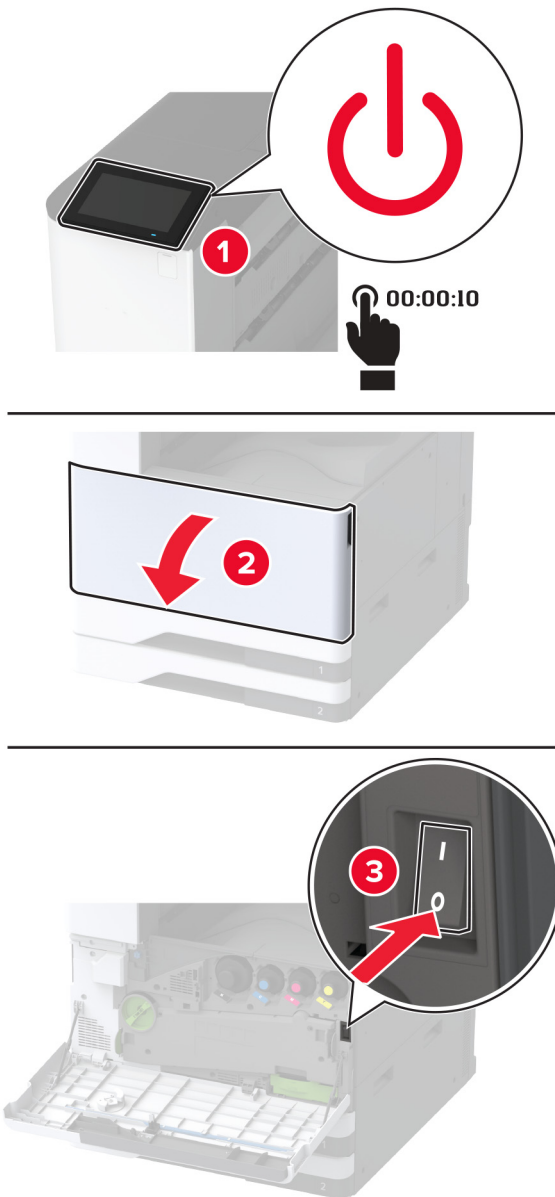

- 2 Unplug the power cord from the electrical outlet, and then from the printer.

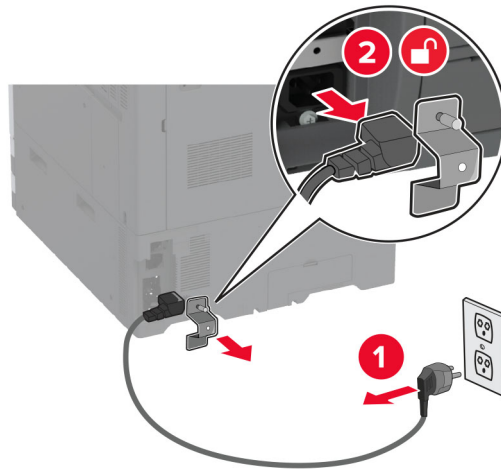

- 3 Unpack the optional tray, and then remove all the packing material.
- 4 Store the sheet that came with the optional tray into the compartment in tray 1.

Note: The sheet has critical information that the service technician needs when repairing or replacing the optional tray.

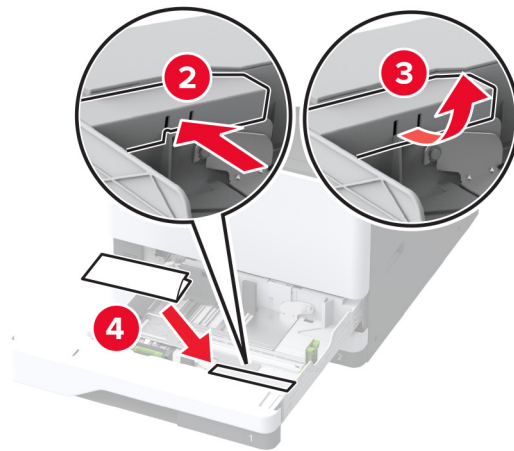
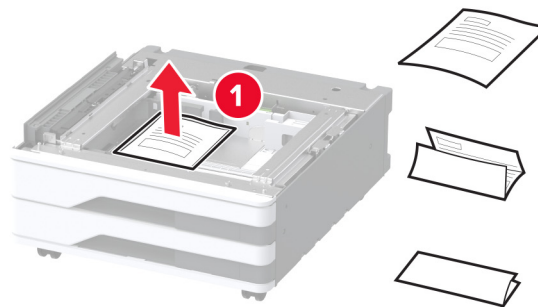

- 5** Lock the casters to keep the optional tray from moving.

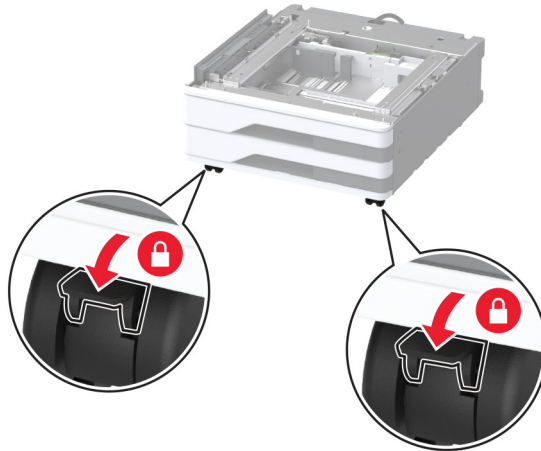

- 6** Remove the option installation cover under the left side of the printer.

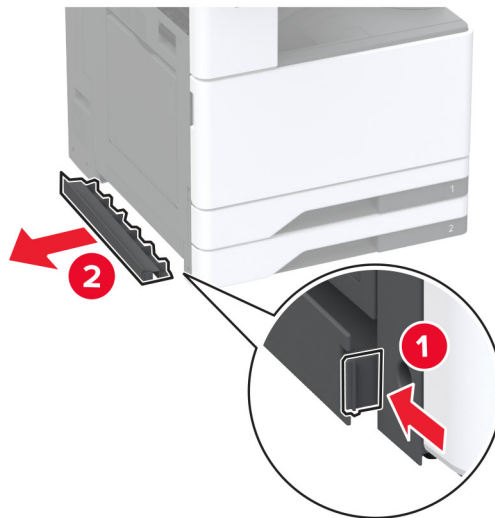

- 7** Pull out the lifting handle on the left side of the printer.

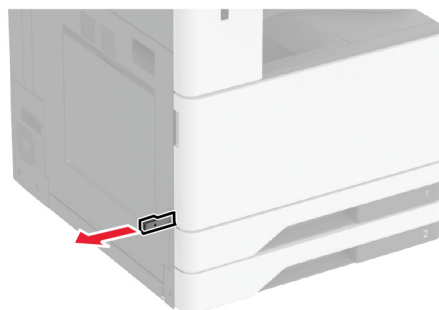

- 8** Align the printer with the optional tray, and then lower the printer into place.

⚠ CAUTION—POTENTIAL INJURY: If the printer weight is greater than 20 kg (44 lb), then it may require two or more people to lift it safely.



9 Remove tray 2.

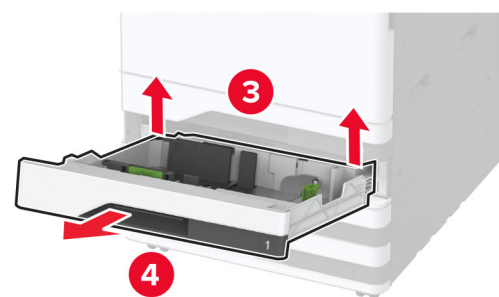
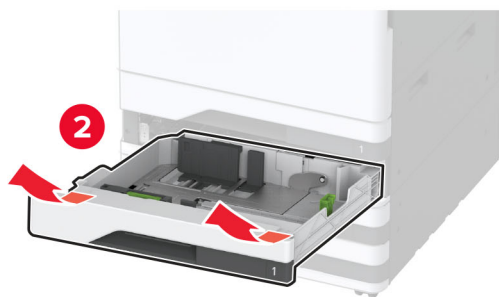

10 Secure the optional tray to the printer with screws.

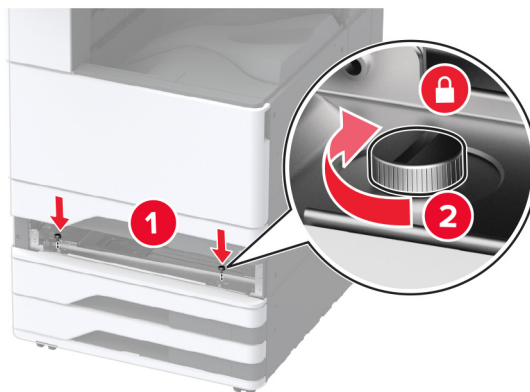

11 Insert tray 2.

12 Remove the connector cover from the rear of the printer.

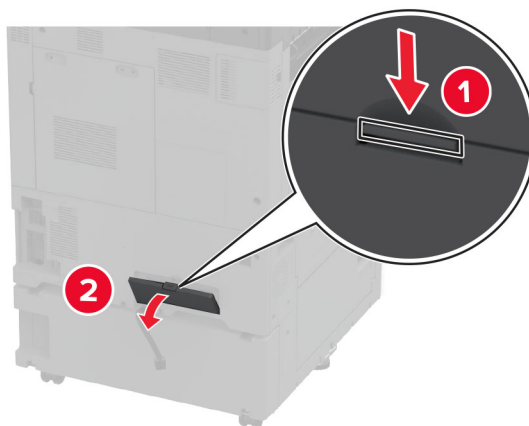

13 Connect the tray connector to the printer, and then attach the cover.

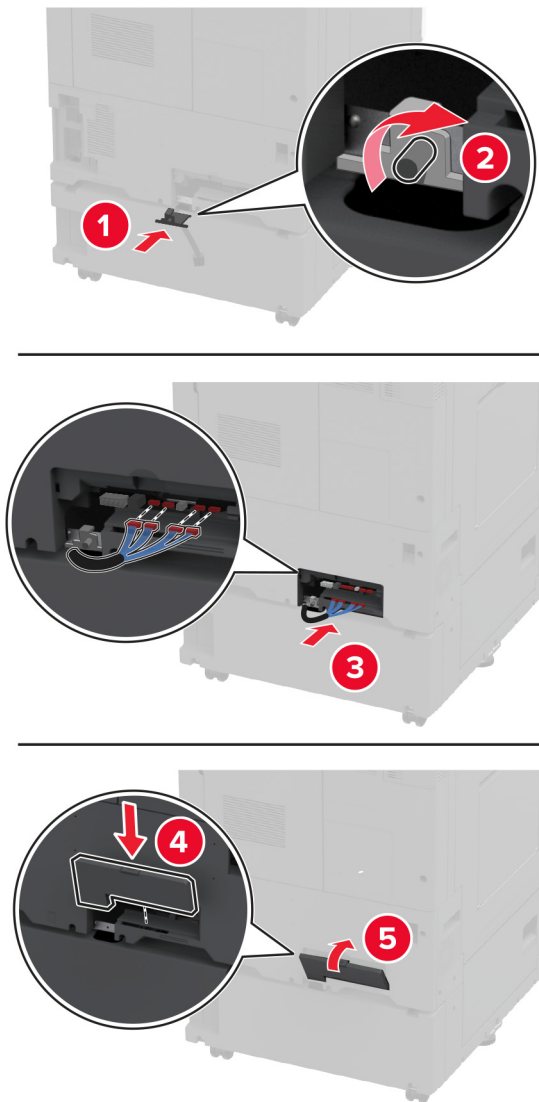

14 Adjust the levelers to make sure that all sides of the printers have the same height.



15 Connect the power cord to the printer, and then to the electrical outlet.



CAUTION—POTENTIAL INJURY: To avoid the risk of fire or electrical shock, connect the power cord to an appropriately rated and properly grounded electrical outlet that is near the product and easily accessible.

16 Turn on the printer.

Add the tray in the print driver to make it available for print jobs. For more information, see [“Adding available options in the print driver” on page 61](#).

Installing the optional 2000-sheet tandem tray

⚠ CAUTION—SHOCK HAZARD: To avoid the risk of electrical shock, if you are accessing the controller board or installing optional hardware or memory devices sometime after setting up the printer, then turn the printer off, and unplug the power cord from the electrical outlet before continuing. If you have any other devices attached to the printer, then turn them off as well, and unplug any cables going into the printer.

- 1 Turn off the printer.

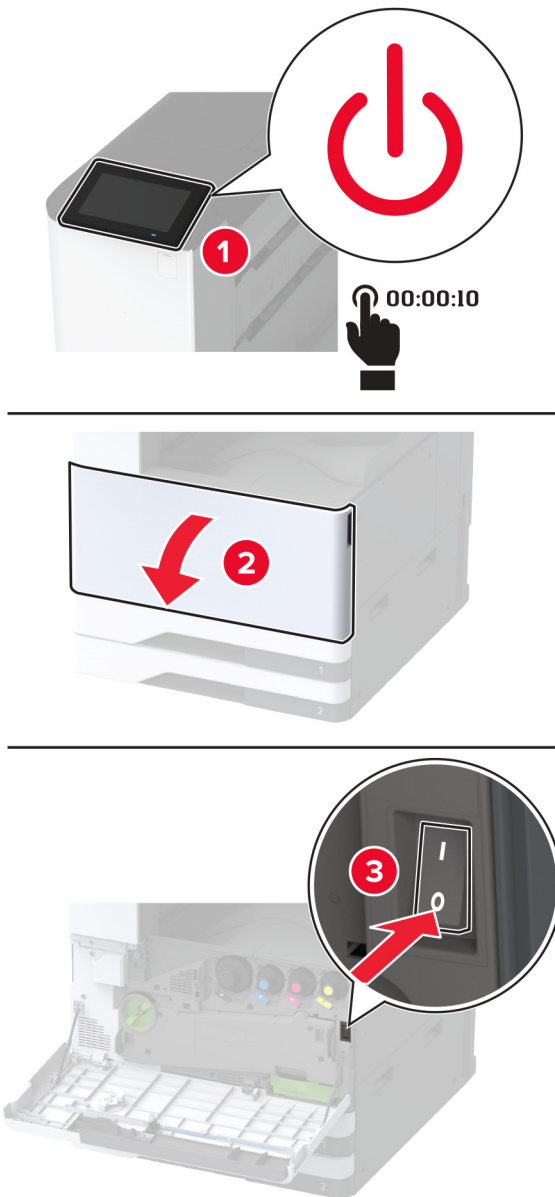

- 2 Unplug the power cord from the electrical outlet, and then from the printer.

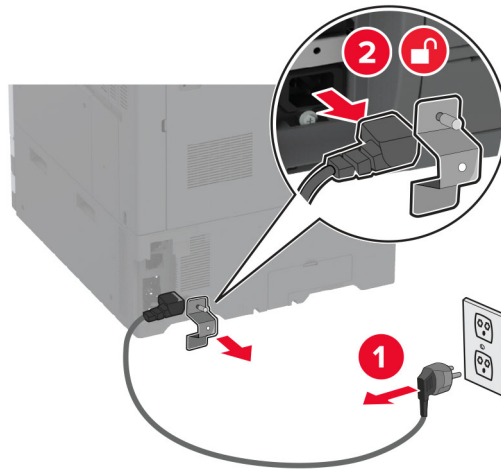

- 3 Unpack the optional tray, and then remove all the packing material.
- 4 Store the sheet that came with the optional tray into the compartment in tray 1.

Note: The sheet has critical information that the service technician needs when repairing or replacing the optional tray.

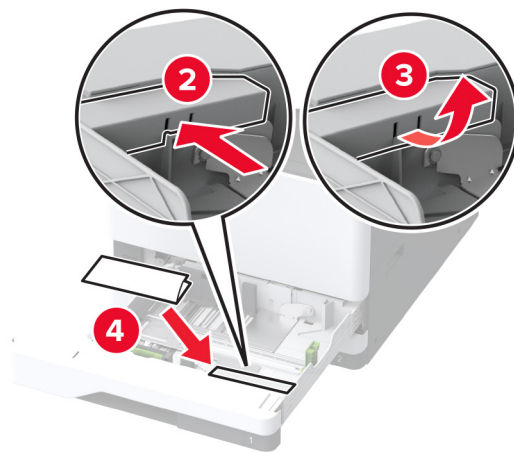
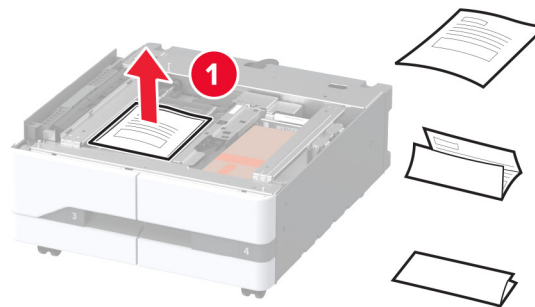

5 Lock the casters to keep the optional tray from moving.

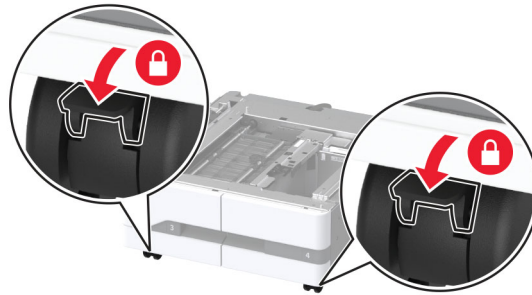

6 Open door B.

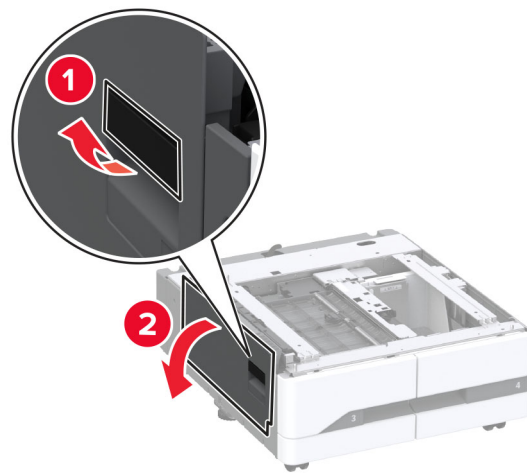

7 Remove the option installation cover under the left side of the printer.

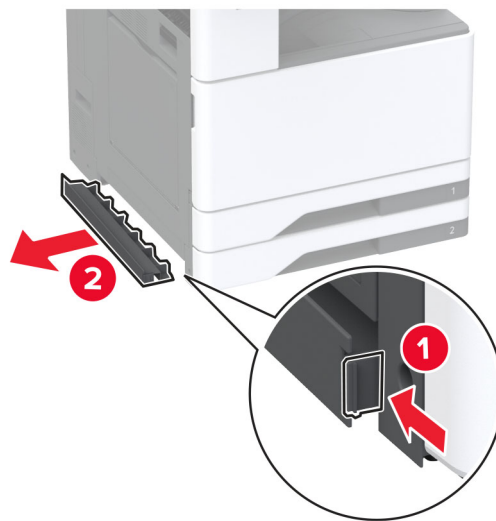

- 8 Pull out the lifting handle on the left side of the printer.

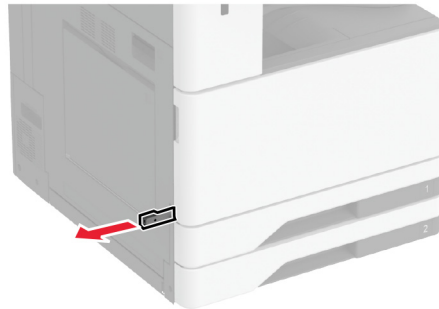

- 9 Align the printer with the optional tray, and then lower the printer into place.

⚠ CAUTION—POTENTIAL INJURY: If the printer weight is greater than 20 kg (44 lb), then it may require two or more people to lift it safely.



- 10 Close door B.

11 Remove tray 2.

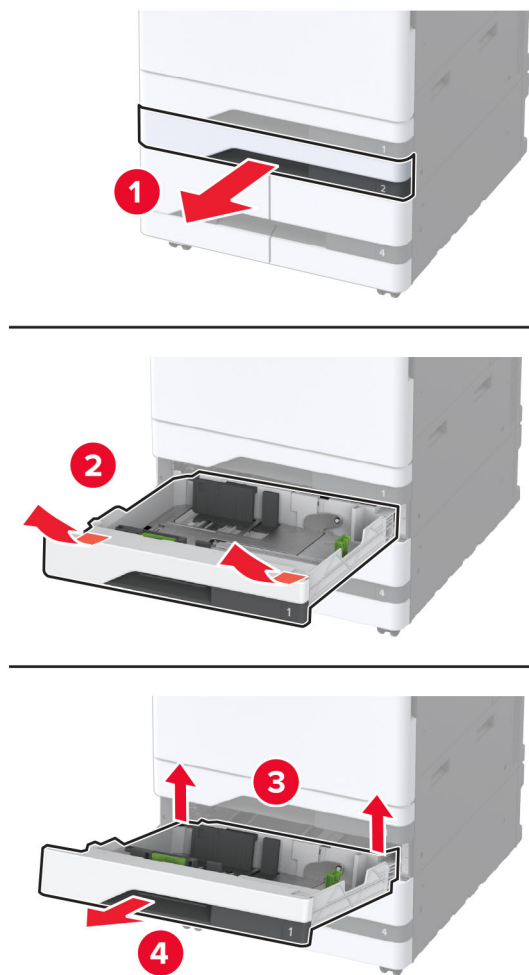

12 Secure the optional tray to the printer with screws.

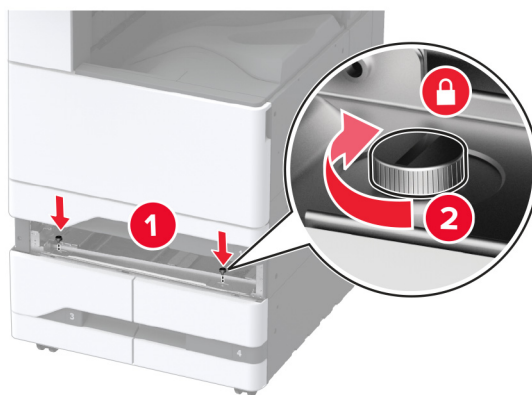

13 Insert tray 2.

14 Remove the connector cover from the rear of the printer.

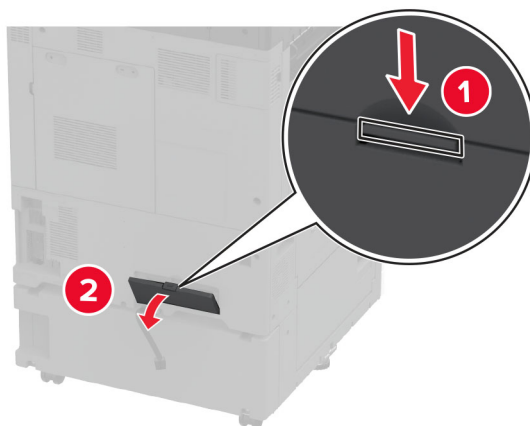

15 Connect the tray connector to the printer, and then attach the cover.

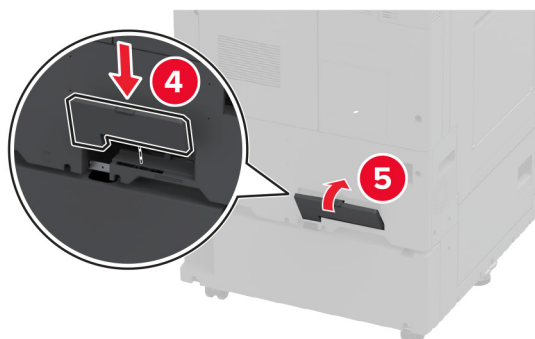
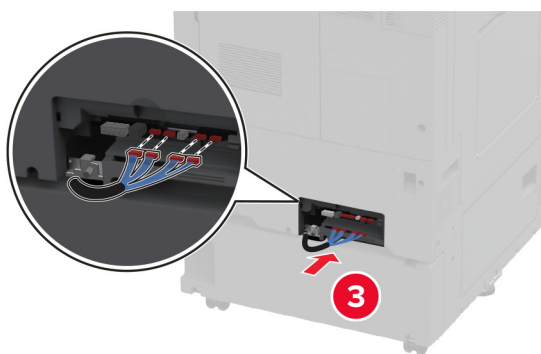
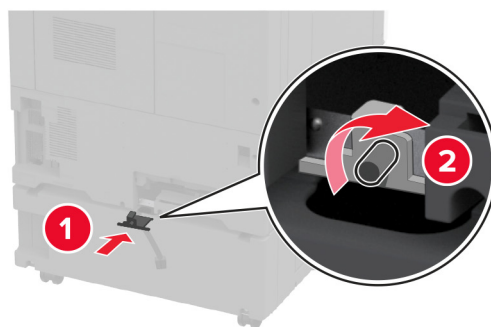

- 16** Adjust the levelers to make sure that all sides of the printers have the same height.

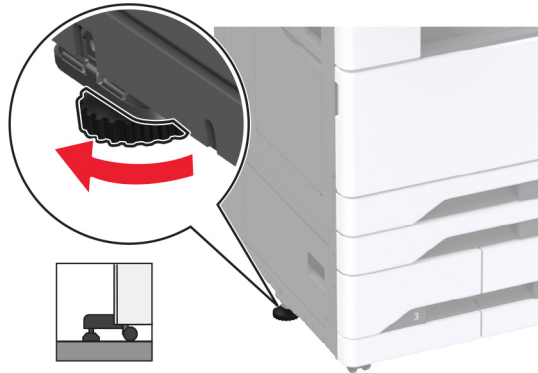

- 17** Connect the power cord to the printer, and then to the electrical outlet.

⚠ CAUTION—POTENTIAL INJURY: To avoid the risk of fire or electrical shock, connect the power cord to an appropriately rated and properly grounded electrical outlet that is near the product and easily accessible.

- 18** Turn on the printer.

Add the tray in the print driver to make it available for print jobs. For more information, see [“Adding available options in the print driver” on page 61](#).

Installing the optional 2000-sheet tray

⚠ CAUTION—SHOCK HAZARD: To avoid the risk of electrical shock, if you are accessing the controller board or installing optional hardware or memory devices sometime after setting up the printer, then turn the printer off, and unplug the power cord from the electrical outlet before continuing. If you have any other devices attached to the printer, then turn them off as well, and unplug any cables going into the printer.

- 1 Turn off the printer.

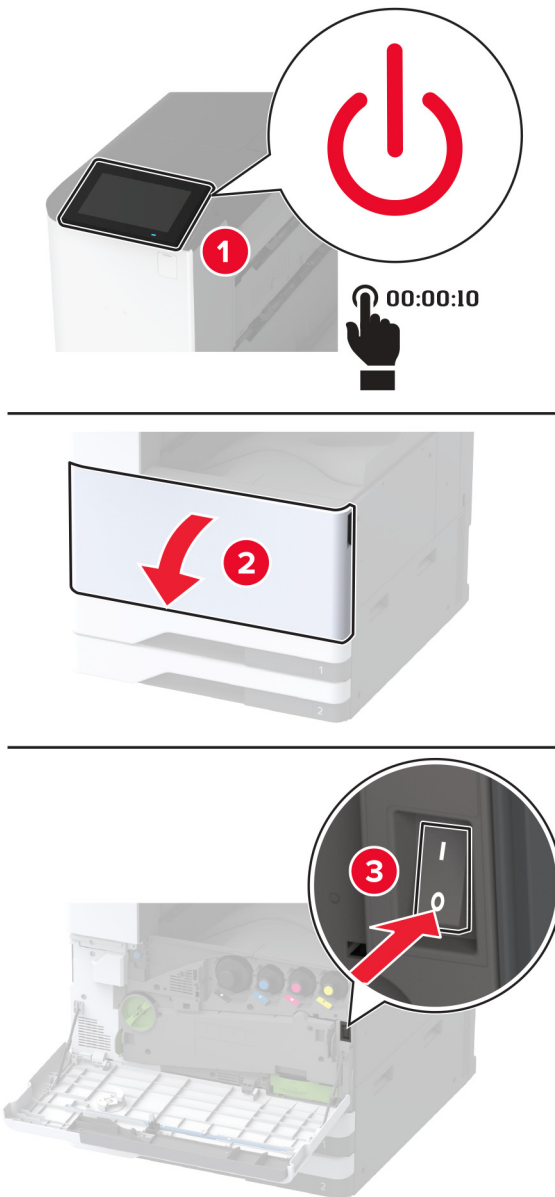

- 2 Unplug the power cord from the electrical outlet, and then from the printer.

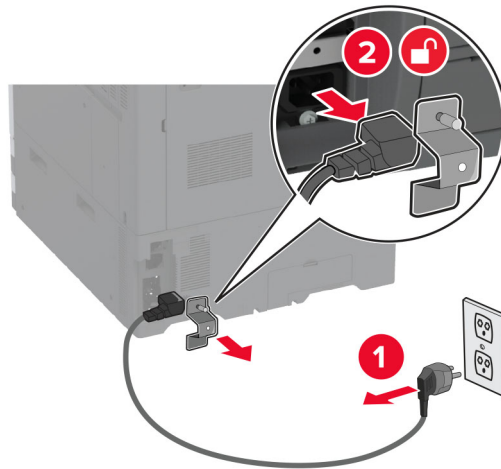

- 3 Unpack the optional tray, and then remove all the packing material.
- 4 Remove the leveling screw from the left side of the printer.

Note: Do not throw away the screw.

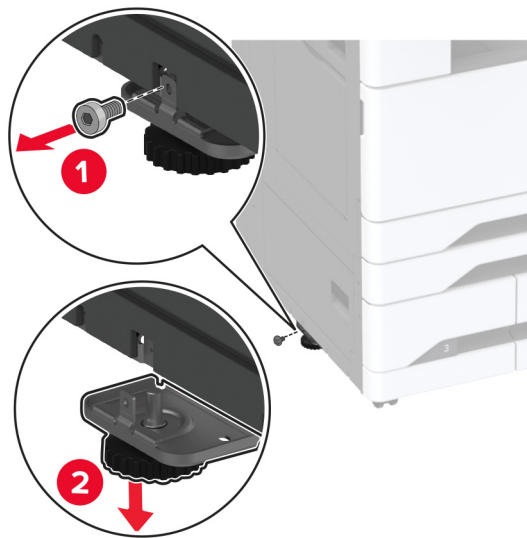

- 5 Attach the docking bracket to the printer.

Note: Use the docking bracket that came with the optional tray.

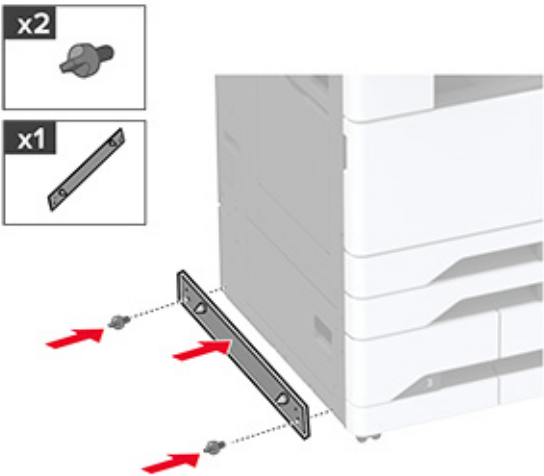

6 Install the optional tray.

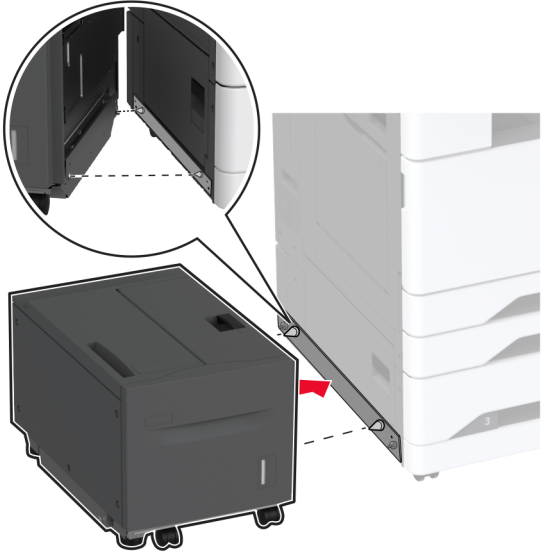

7 Connect the tray connector to the printer.

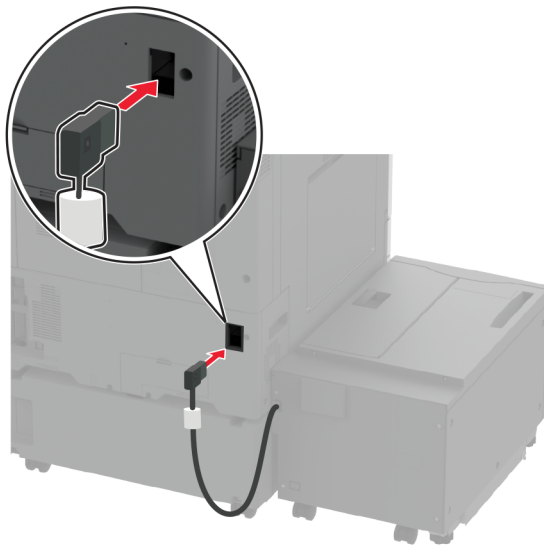

- 8 Adjust the leveling screws to make sure that the tray has the same height with the printer.

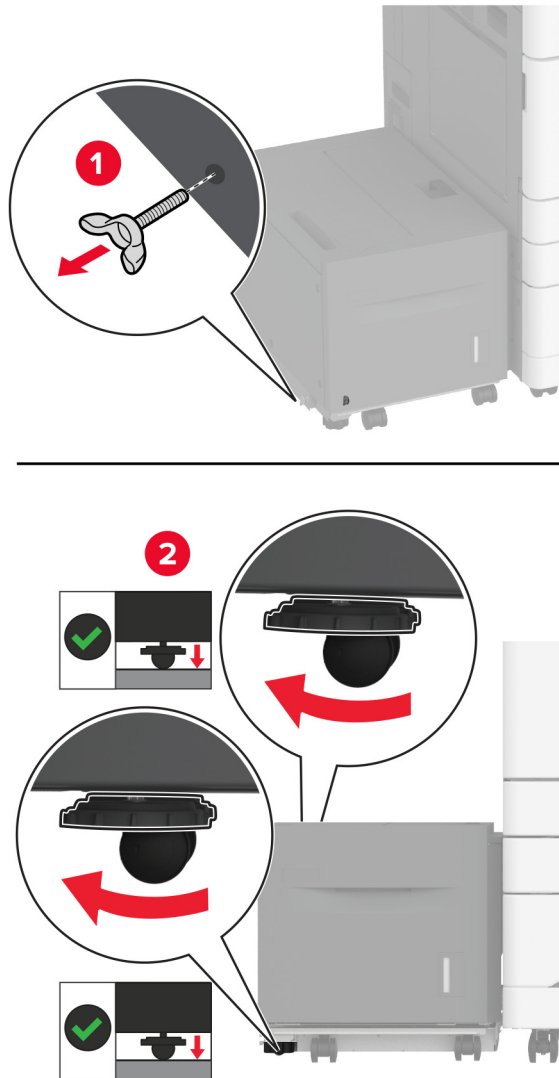

- 9 Connect the power cord to the printer, and then to the electrical outlet.

⚠ CAUTION—POTENTIAL INJURY: To avoid the risk of fire or electrical shock, connect the power cord to an appropriately rated and properly grounded electrical outlet that is near the product and easily accessible.

- 10 Turn on the printer.

Add the tray in the print driver to make it available for print jobs. For more information, see [“Adding available options in the print driver” on page 61](#).

Installing the banner tray

- 1 Turn off the printer.

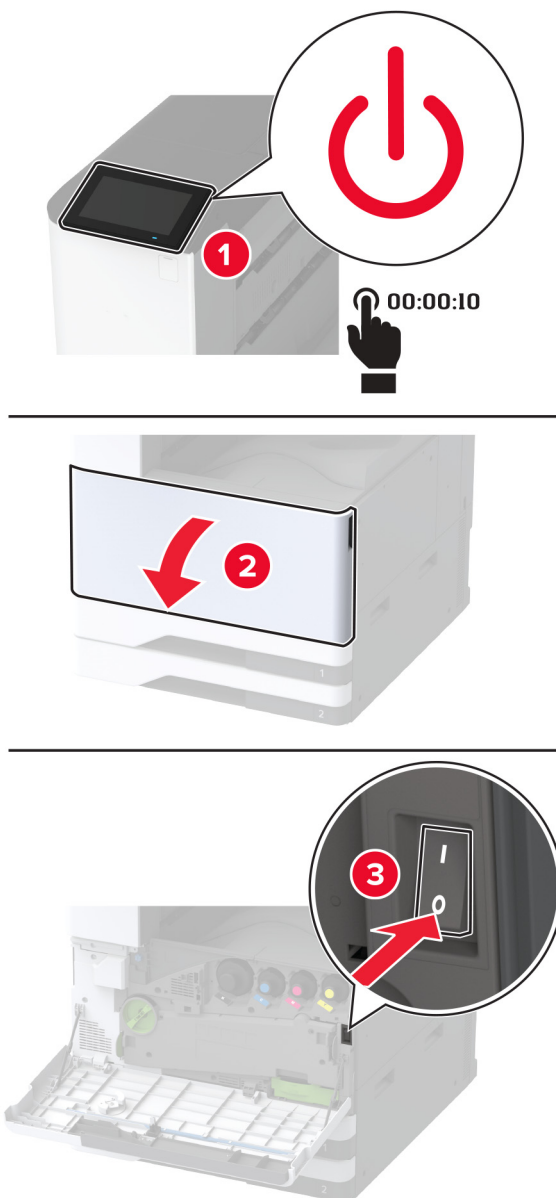

- 2** Unplug the power cord from the electrical outlet, and then from the printer.

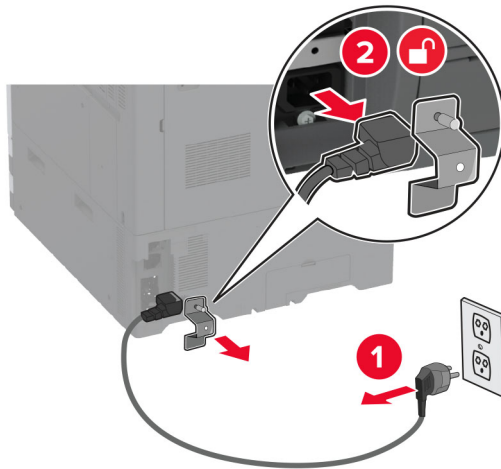

- 3** Open the multipurpose feeder, and then extend the side guides.

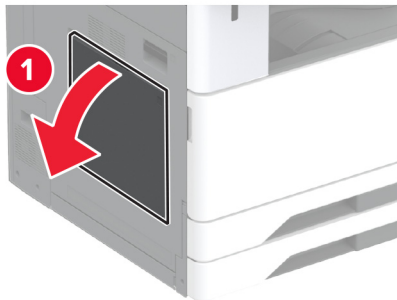

- 4** Unpack the banner tray, and then remove all the packing material.

5 Attach the banner tray to the multipurpose feeder.

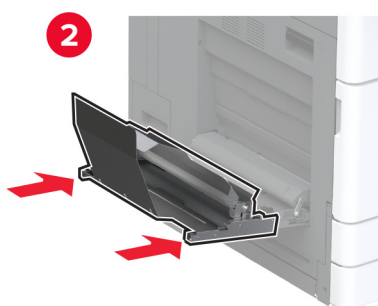
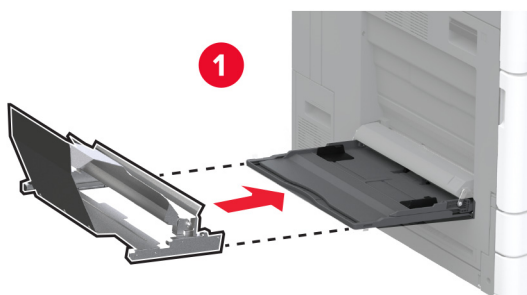

6 Push the banner roll catch toward the printer.

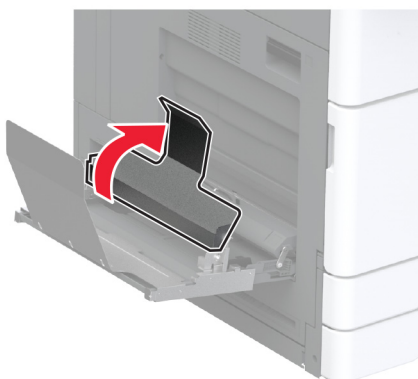

7 Load banner paper into the tray, with the leading edge going under the banner roll catch.

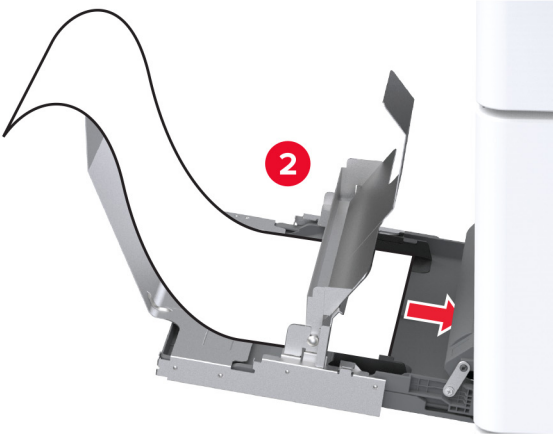
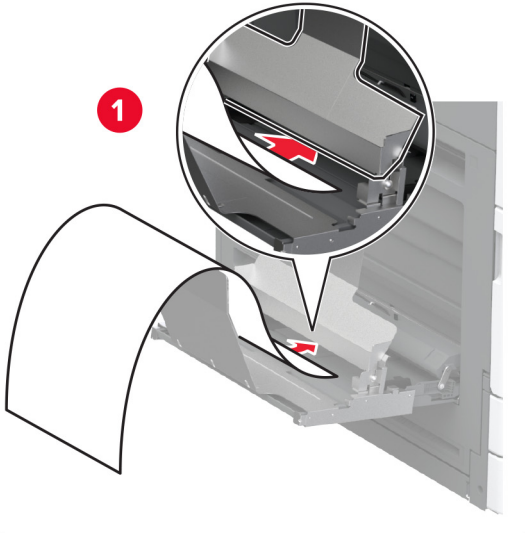

- 8 Place the trailing edge of the banner paper on the banner roll catch, and then adjust the side guides.

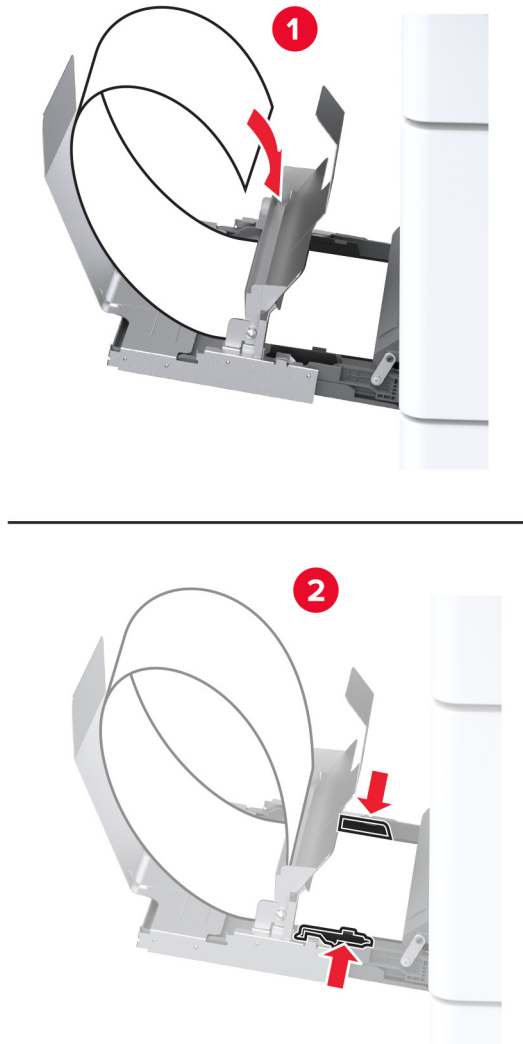

- 9 Connect the power cord to the printer, and then to the electrical outlet.

⚠ CAUTION—POTENTIAL INJURY: To avoid the risk of fire or electrical shock, connect the power cord to an appropriately rated and properly grounded electrical outlet that is near the product and easily accessible.

- 10 Turn on the printer.

Installing the dual catch bin

- 1 Unpack the dual catch bin.
- 2 Attach the dual catch bin to the printer.

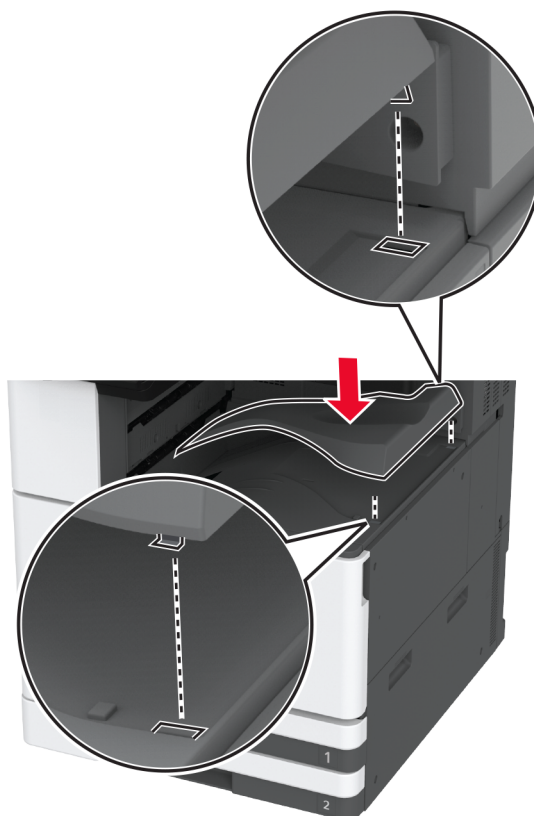

Installing the staple finisher

⚠ CAUTION—SHOCK HAZARD: To avoid the risk of electrical shock, if you are accessing the controller board or installing optional hardware or memory devices sometime after setting up the printer, then turn the printer off, and unplug the power cord from the electrical outlet before continuing. If you have any other devices attached to the printer, then turn them off as well, and unplug any cables going into the printer.

- 1 Turn off the printer.

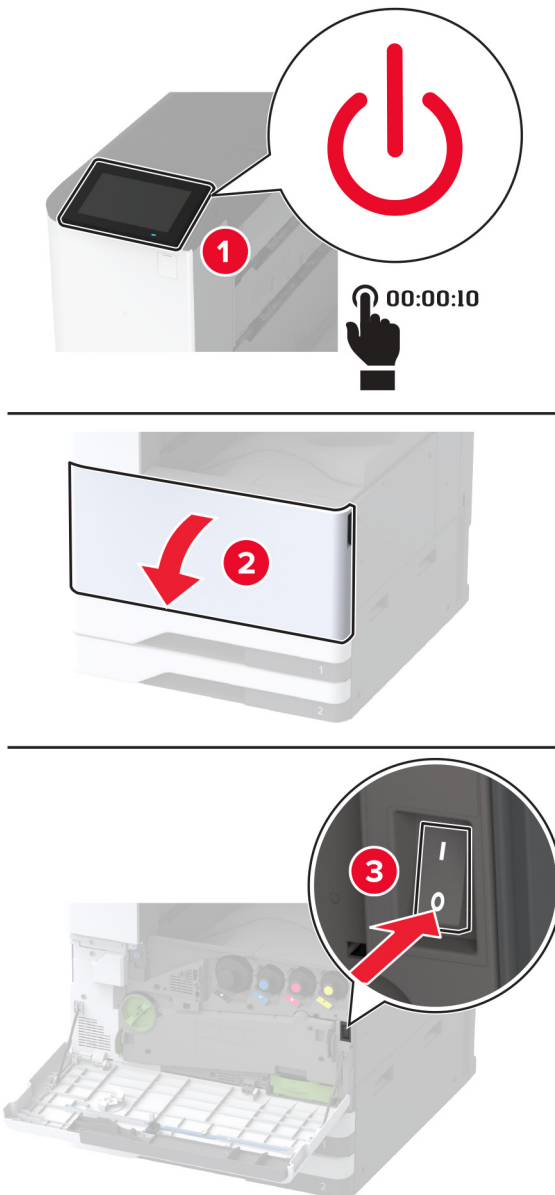

- 2 Unplug the power cord from the electrical outlet, and then from the printer.

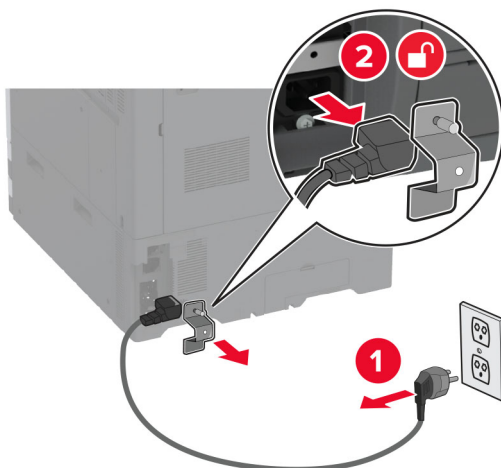

- 3 Remove the standard bin.

Note: Do not throw away the bin.

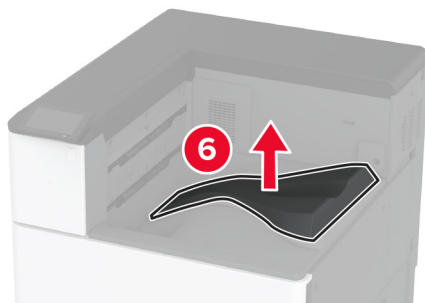
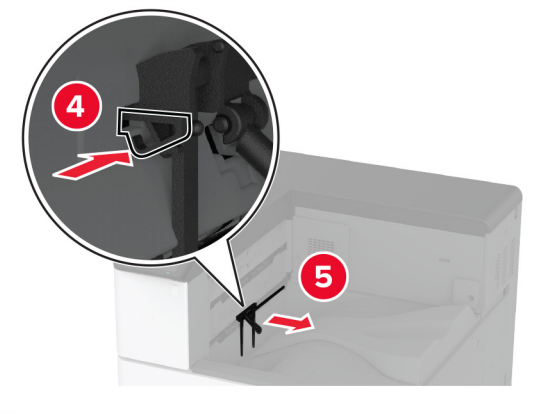
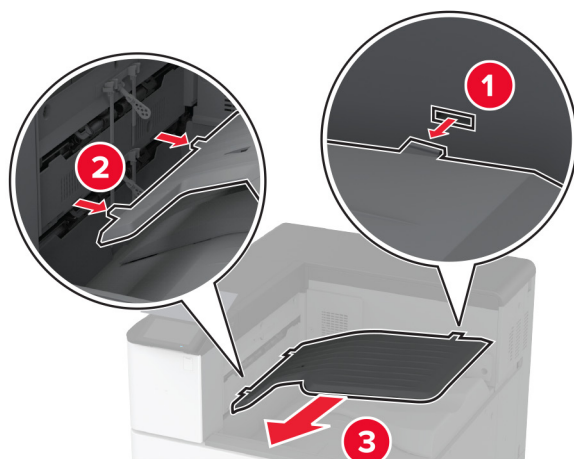

4 Open the front door, and then remove the blue knob.

Note: Do not throw away the knob.

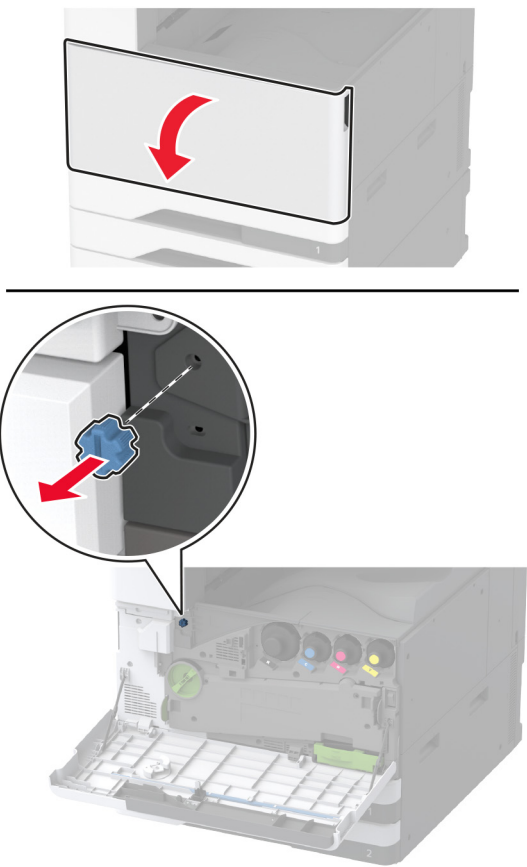

- 5** Remove the standard bin side cover.
Note: Do not throw away the cover.

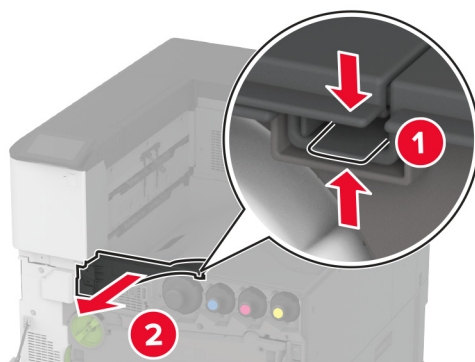

- 6** Unpack the staple finisher, and then remove all the packing material.

- 7** Insert the finisher.

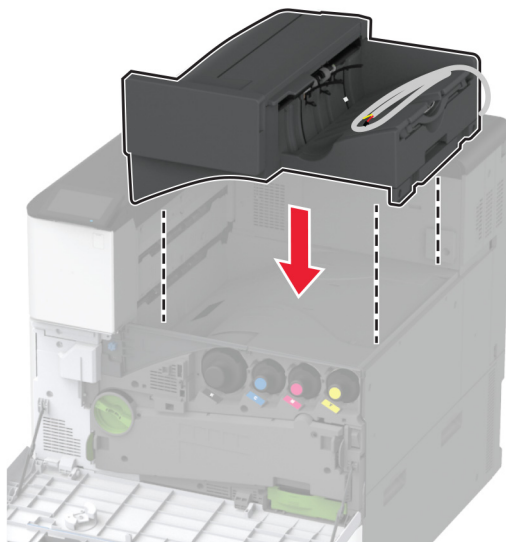

- 8** Close the front door.

- 9** Secure the finisher to the printer.

Note: Use the screws that came with the finisher.

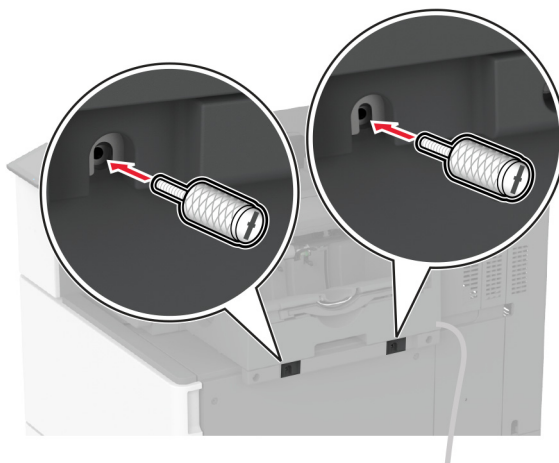

- 10** Secure the finisher cable to the printer.

Note: Use the clamps that came with the finisher.

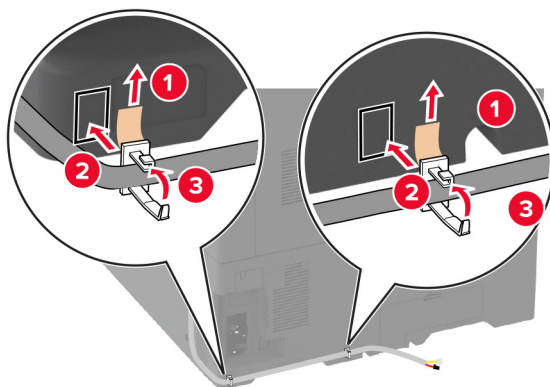
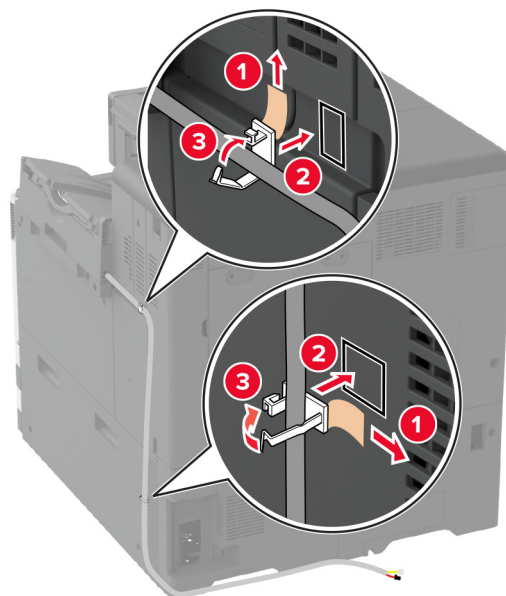

11 Connect the finisher cable to the printer.

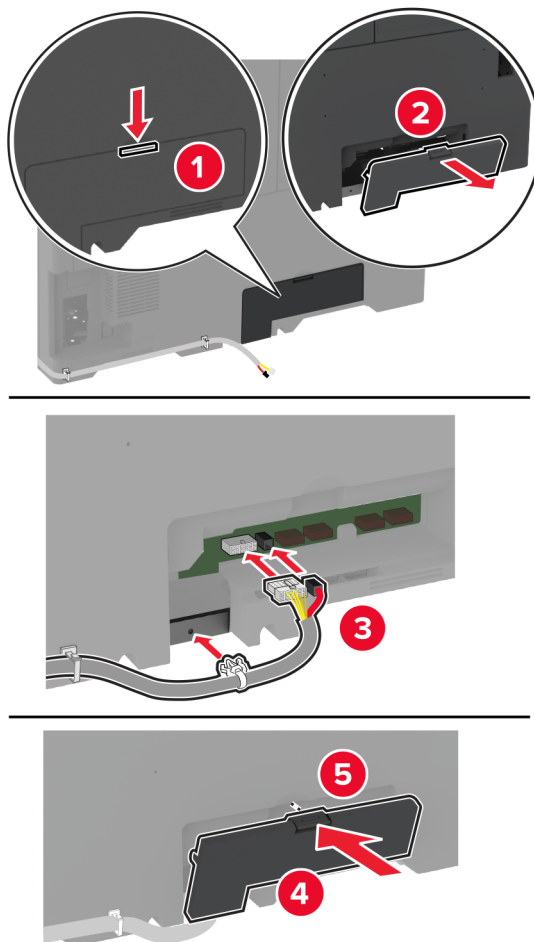

12 Connect the power cord to the printer, and then to the electrical outlet.

⚠ CAUTION—POTENTIAL INJURY: To avoid the risk of fire or electrical shock, connect the power cord to an appropriately rated and properly grounded electrical outlet that is near the product and easily accessible.

13 Turn on the printer.

Add the finisher in the print driver to make it available for print jobs. For more information, see [“Adding available options in the print driver” on page 61](#).

Installing the staple, hole punch finisher

⚠ CAUTION—SHOCK HAZARD: To avoid the risk of electrical shock, if you are accessing the controller board or installing optional hardware or memory devices sometime after setting up the printer, then turn the printer off, and unplug the power cord from the electrical outlet before continuing. If you have any other devices attached to the printer, then turn them off as well, and unplug any cables going into the printer.

- 1 Turn off the printer.

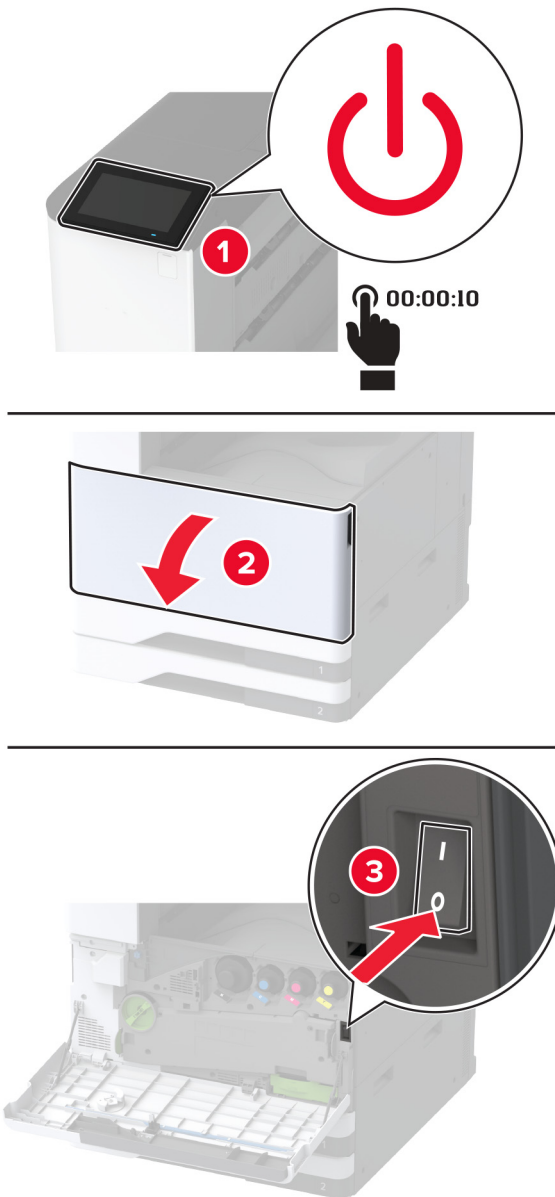

- 2** Unplug the power cord from the electrical outlet, and then from the printer.

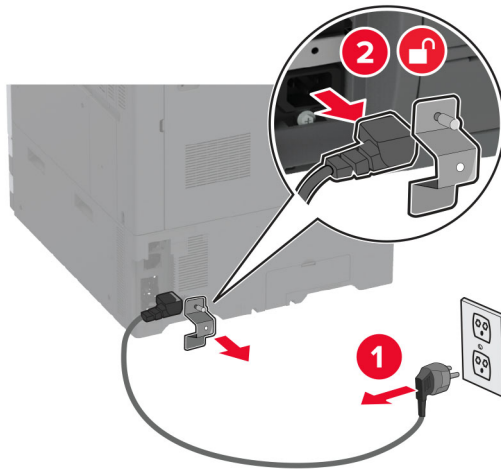

- 3** Unpack the staple, hole punch finisher, and then remove all the packing material.
- 4** Insert the staple cartridge holder into the finisher.

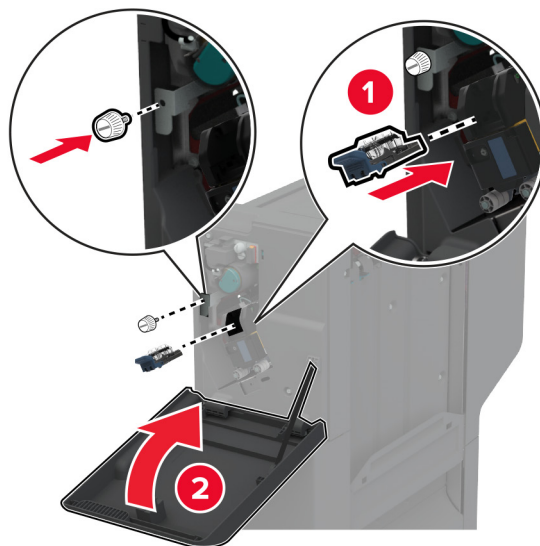
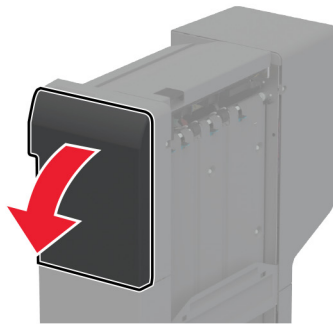

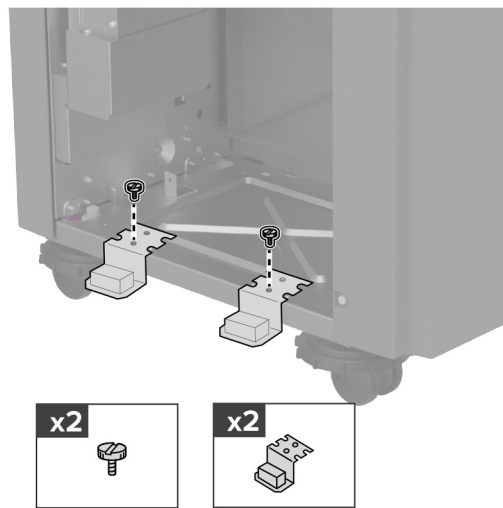
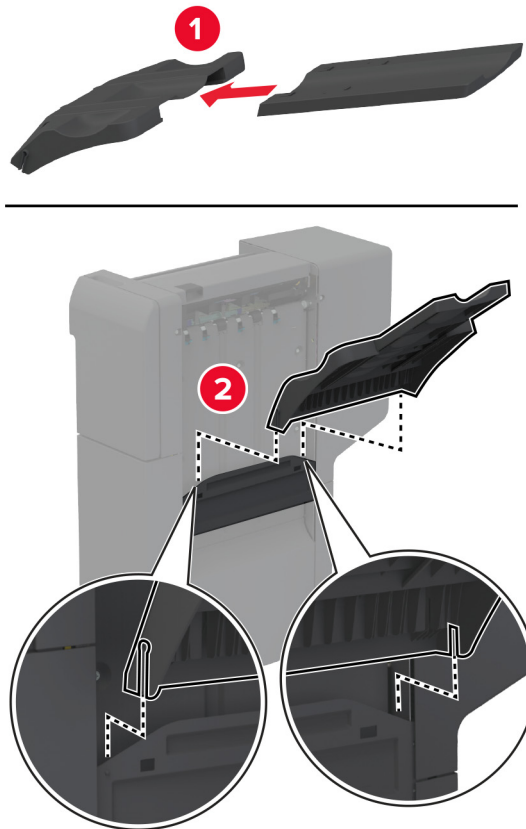
5 Attach the brackets to the finisher.**6** Insert the bin into the finisher.**7** Remove the standard bin.

Note: Do not throw away the standard bin.

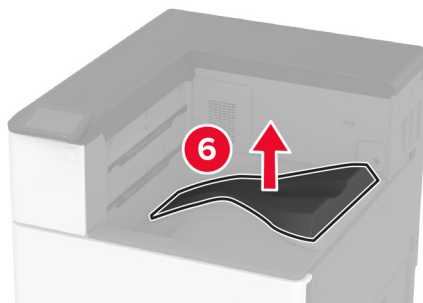
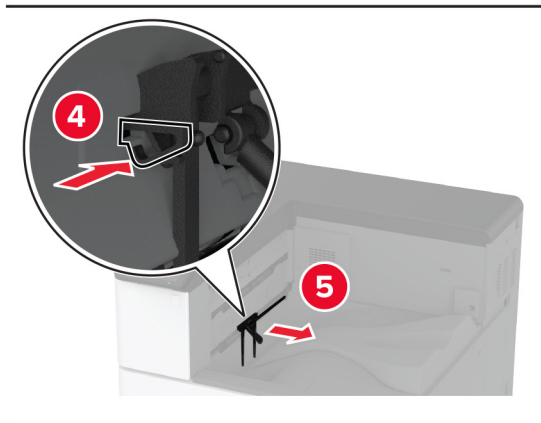
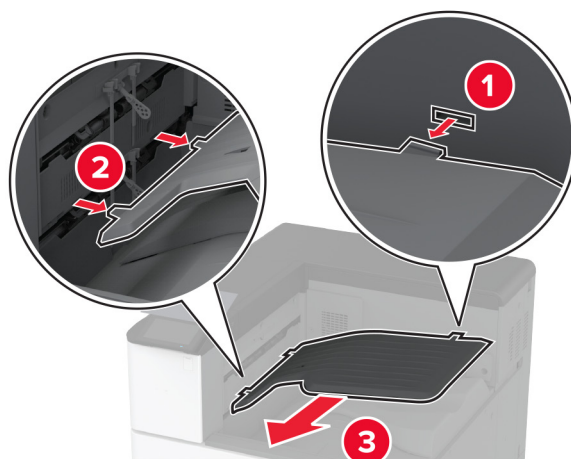

8 Open the front door, and then remove the blue knob.

Note: Do not throw away the blue knob.

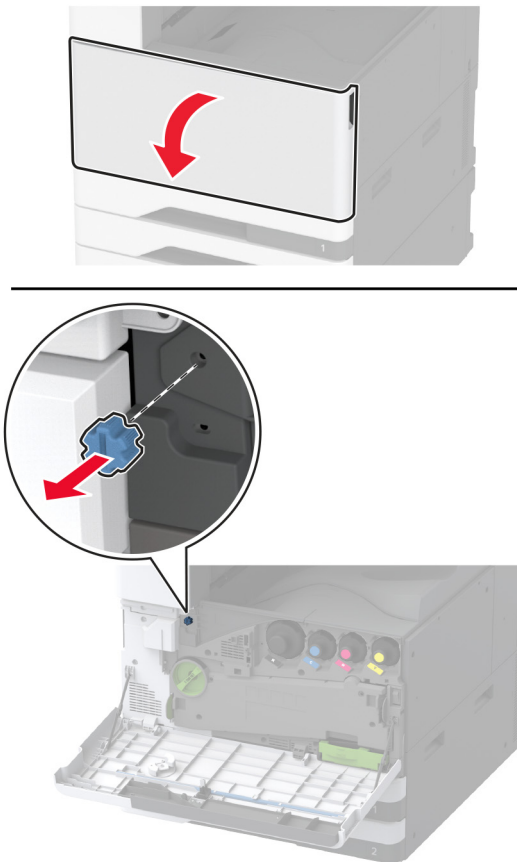

9 Remove the standard bin side cover.

Note: Do not throw away the standard bin side cover.

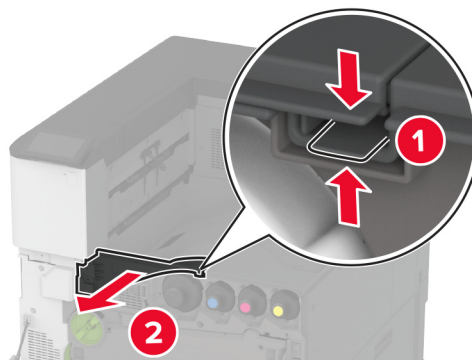

10 Close the front door.

11 Insert the paper transport, and then use the screws to secure it.

Note: Use the screws that came with the finisher.

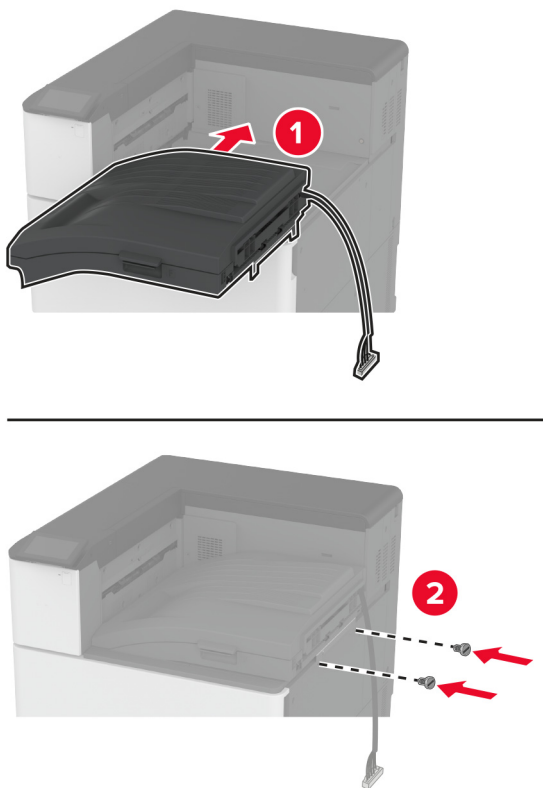

12 Attach the finisher to the printer.

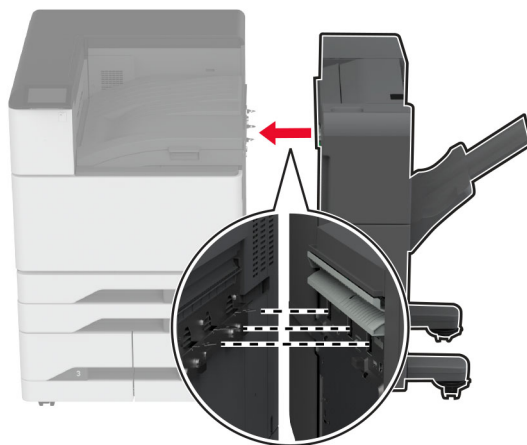

13 Adjust the leveling screws to make sure that all sides of the finisher have the same height as the printer.

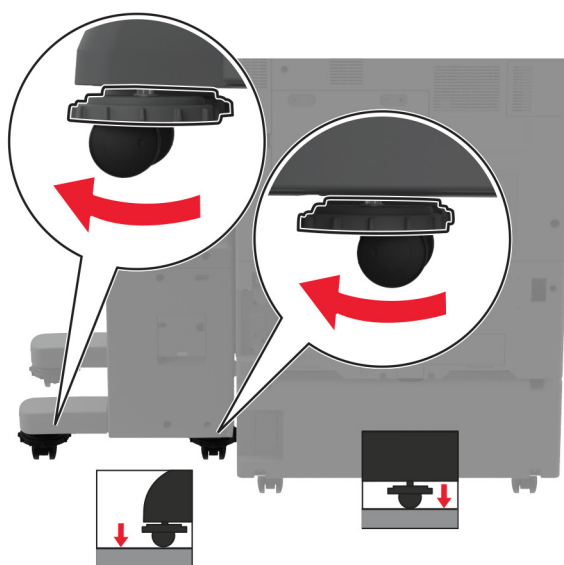
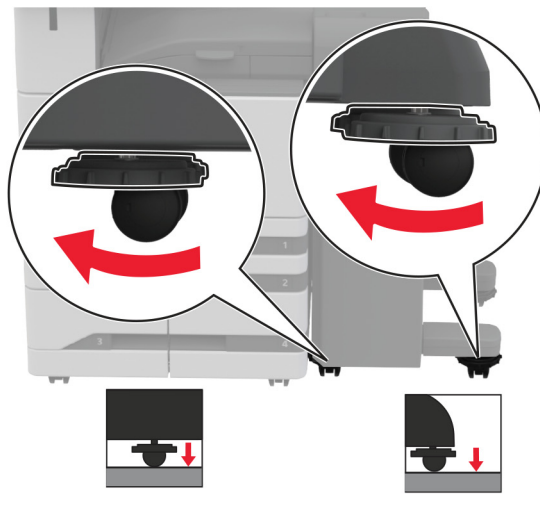

14 Open the finisher door, and then install the screw to the left part of the finisher.

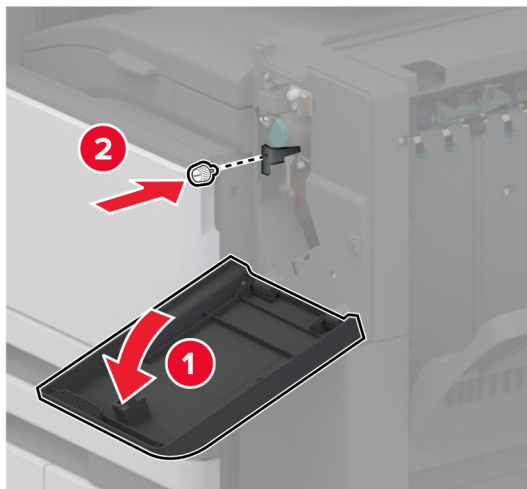

15 Close the finisher door.

16 Connect the paper transport cable to the rear of the finisher.

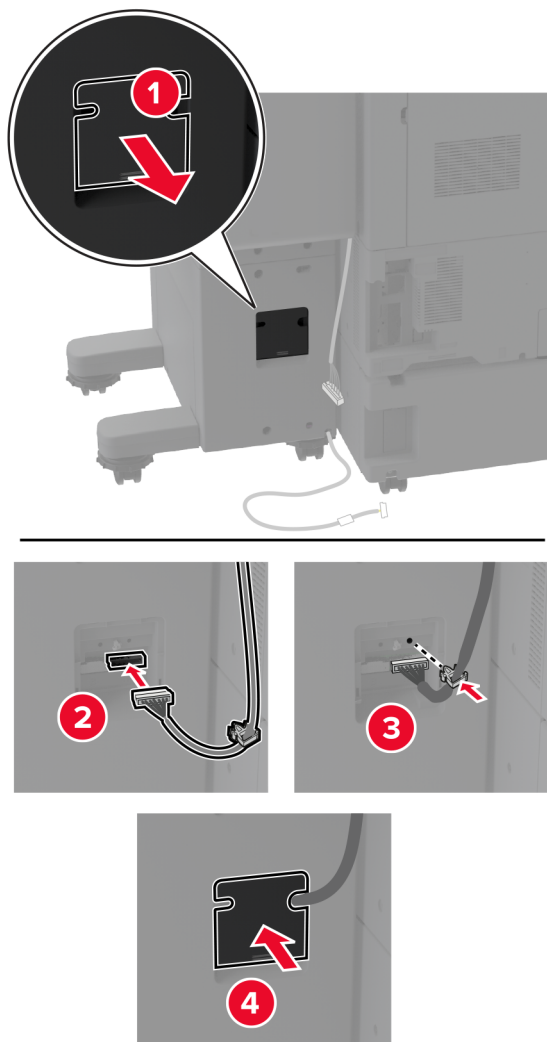

- 17** Connect the finisher cable to the rear of the printer.

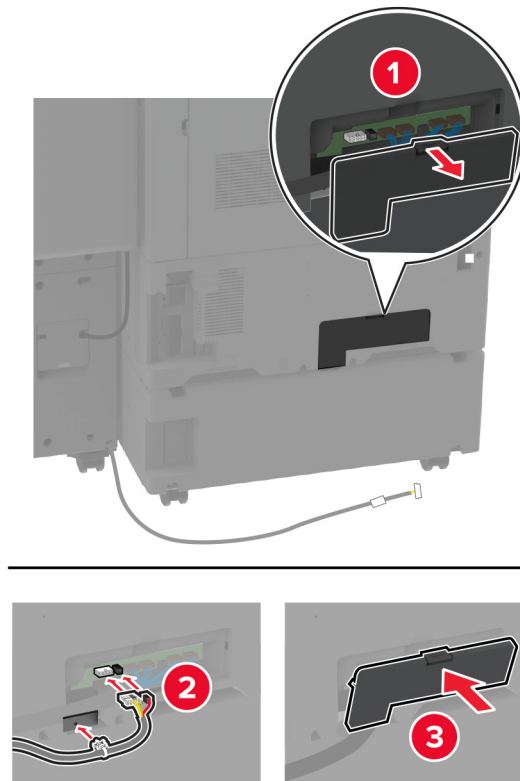

- 18** Secure the cable along the rear of the printer.

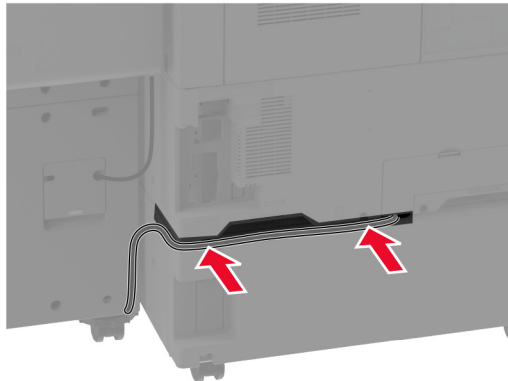

- 19** Connect the power cord to the printer, and then to the electrical outlet.

⚠ CAUTION—POTENTIAL INJURY: To avoid the risk of fire or electrical shock, connect the power cord to an appropriately rated and properly grounded electrical outlet that is near the product and easily accessible.

- 20** Turn on the printer.

To make the finisher available for print jobs, from the home screen, touch **Settings > Device > Maintenance > Configuration Menu > Finisher Configuration > Hole Punch Configuration** > select a configuration.

Installing the booklet finisher

CAUTION—SHOCK HAZARD: To avoid the risk of electrical shock, if you are accessing the controller board or installing optional hardware or memory devices sometime after setting up the printer, then turn the printer off, and unplug the power cord from the electrical outlet before continuing. If you have any other devices attached to the printer, then turn them off as well, and unplug any cables going into the printer.

- 1 Turn off the printer.

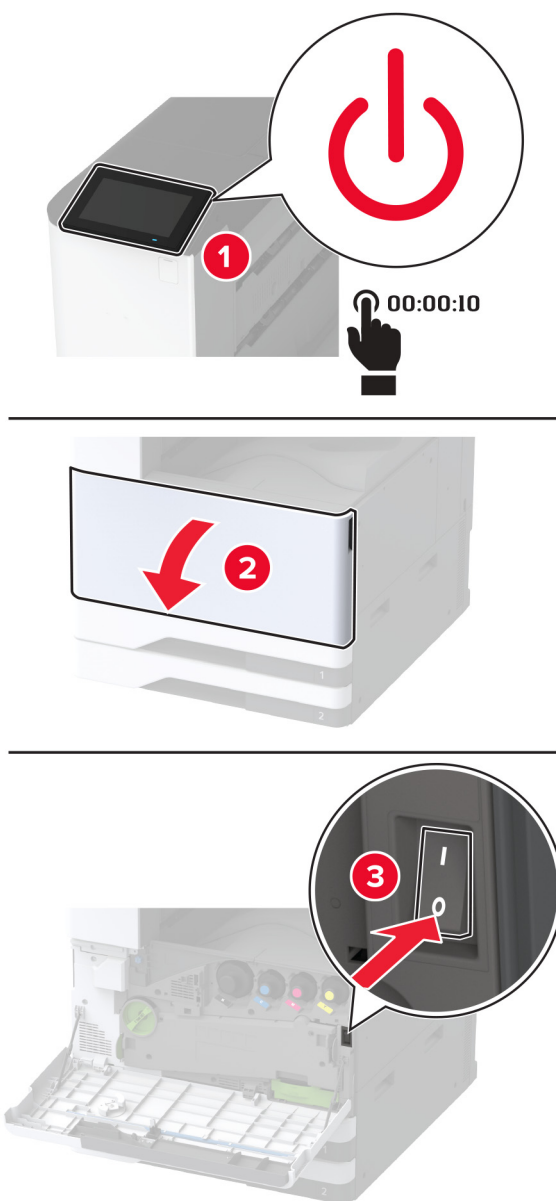

- 2 Unplug the power cord from the electrical outlet, and then from the printer.

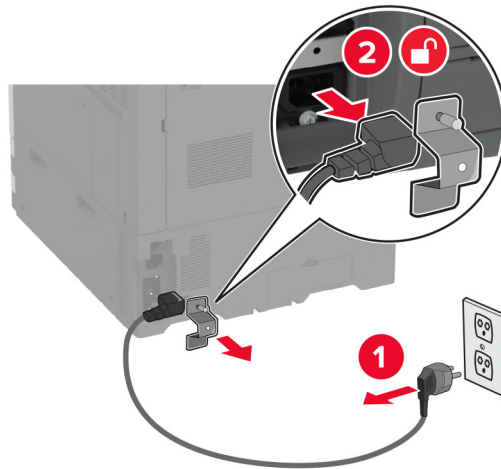

- 3 Unpack the booklet finisher, and then remove all the packing material.
- 4 Open the booklet finisher door.

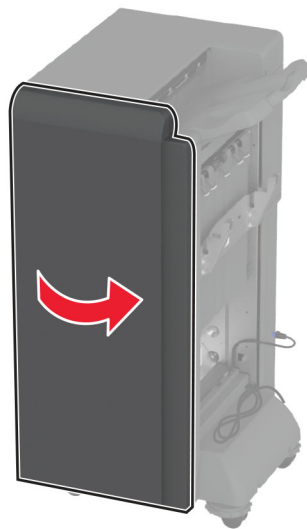

5 Remove the packing material inside the booklet finisher.

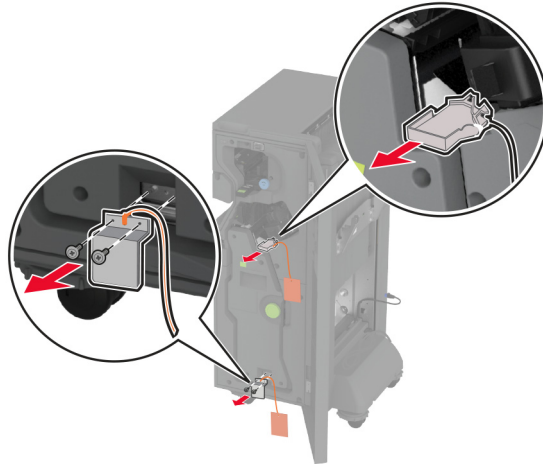

6 Insert the staple cartridge holder.



7 Insert the hole punch box.

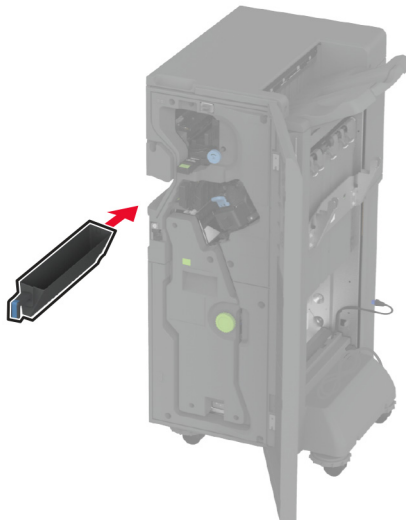

8 Close the booklet finisher door.

9 Insert the bins.

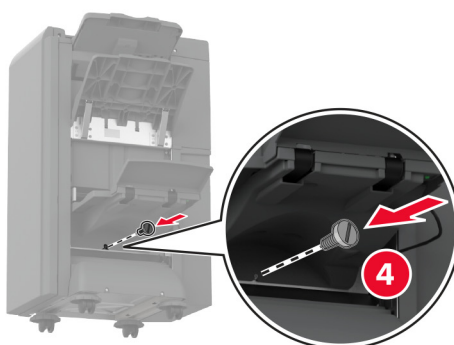
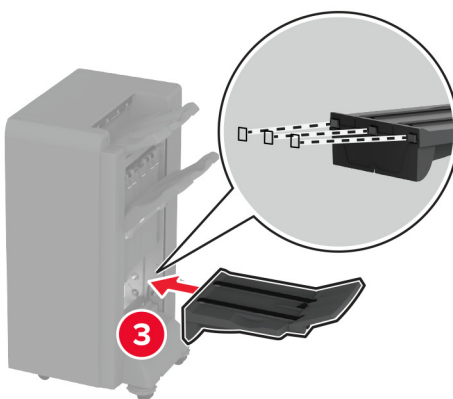
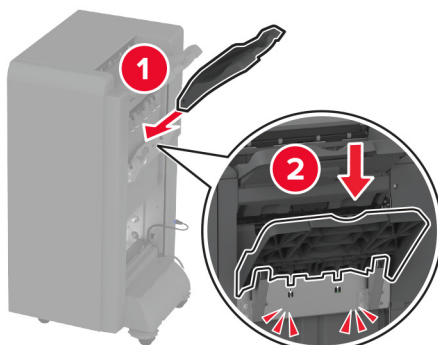

10 Insert the booklet finisher cable.

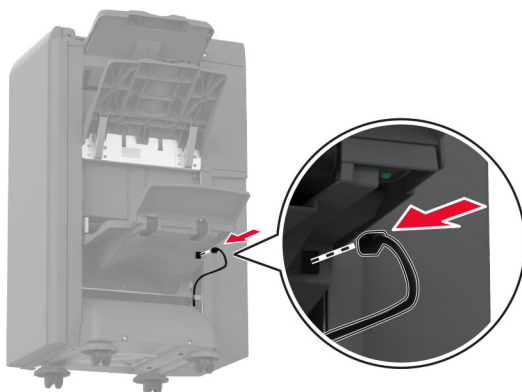

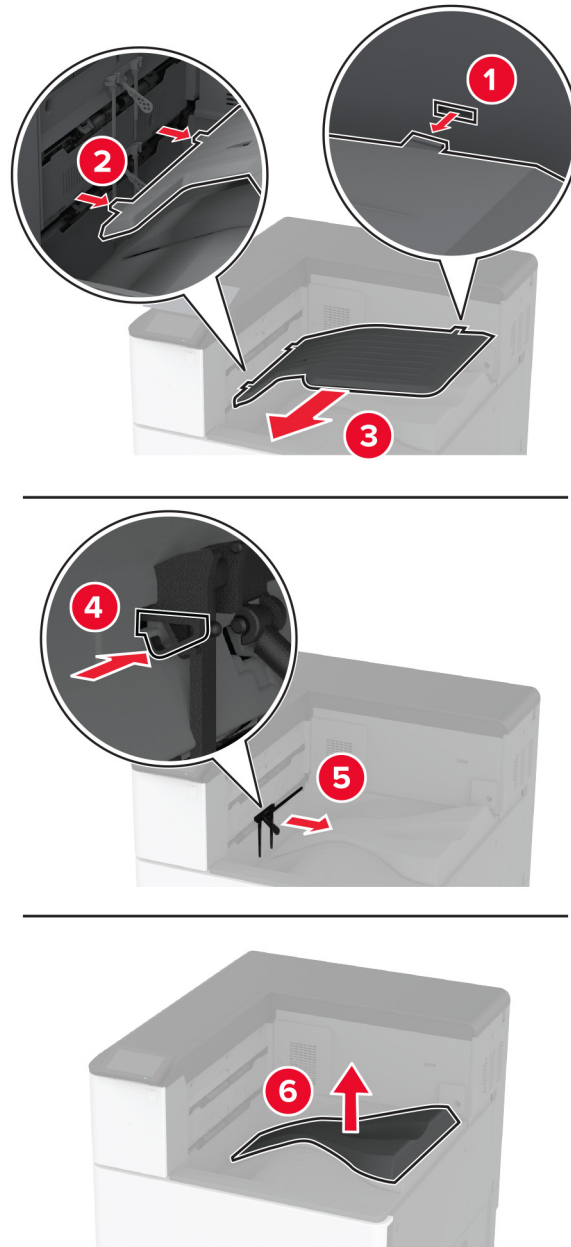
11 Remove the standard bin.

Note: Do not throw away the standard bin.

12 Open the front door, and then remove the blue knob.

Note: Do not throw away the knob.

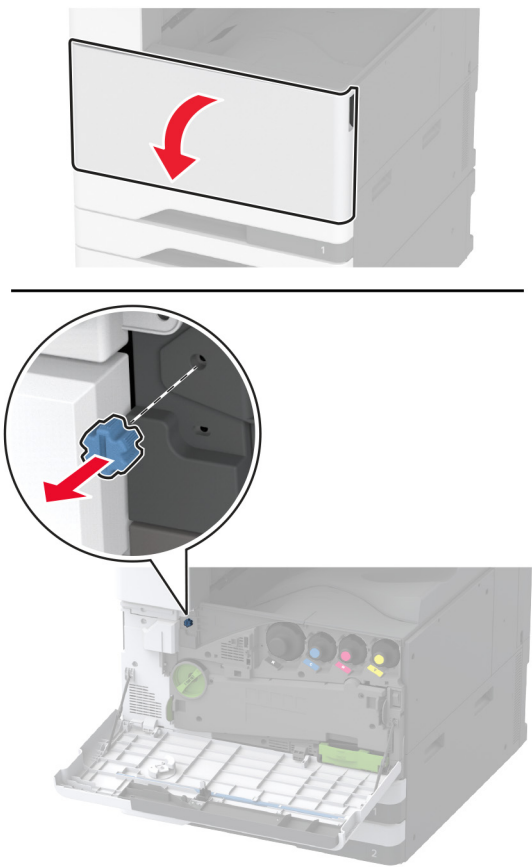

13 Remove the standard bin side cover.

Note: Do not throw away the bin side cover.

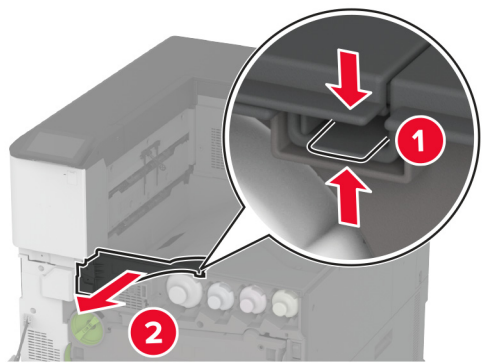

14 Close the front door.

- 15** Attach the installation bracket for the finisher.

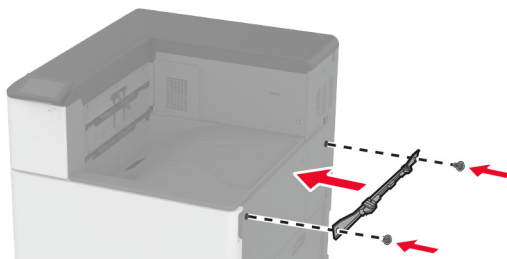

- 16** Insert the paper transport, and then use the screws to secure it.

Note: Use the screws that came with the finisher.

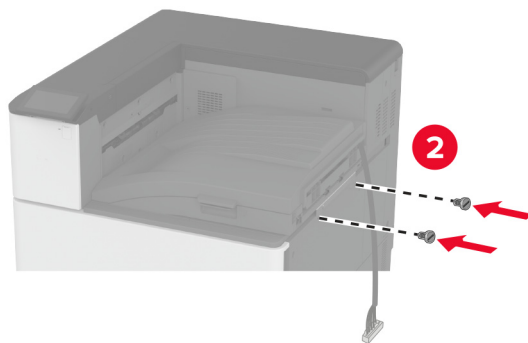
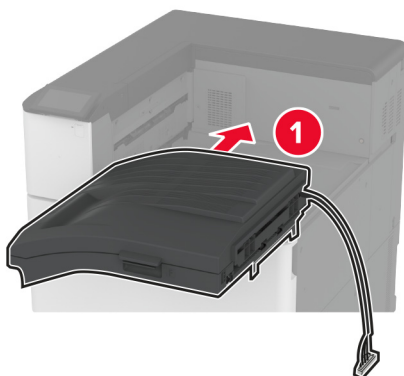

17 Remove the rear ports cover.

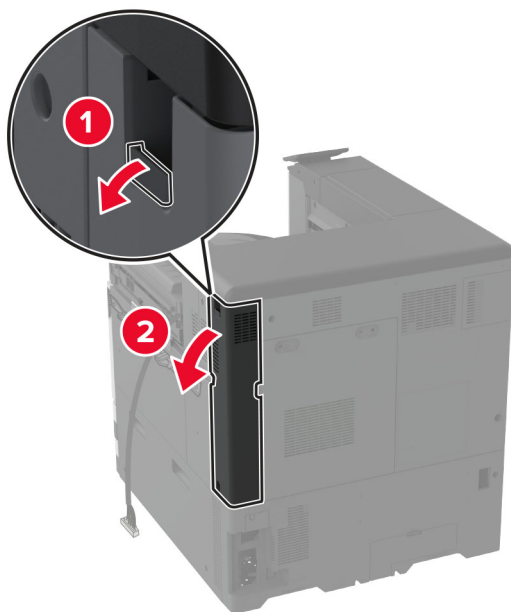

18 Secure the cable.

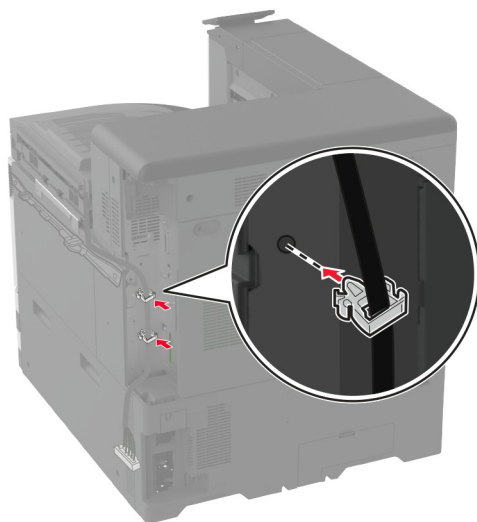

19 Attach the rear ports cover.

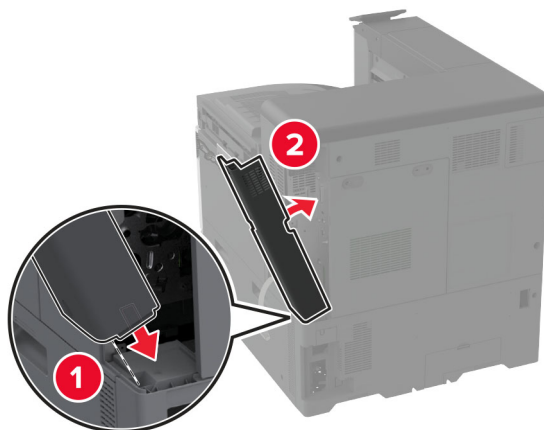

20 Attach the brackets at the bottom of the finisher.

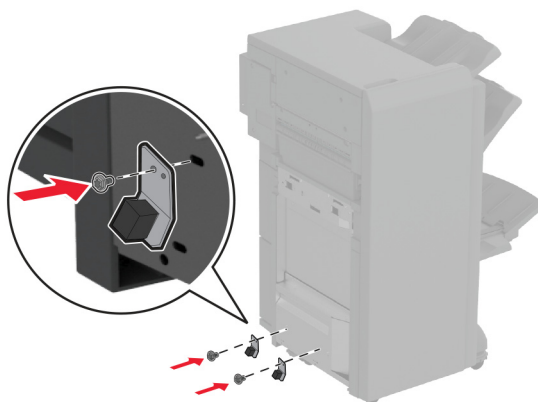

21 Open the booklet finisher door.

22 Using a flat-head screwdriver, remove the screw, and then close the finisher door.

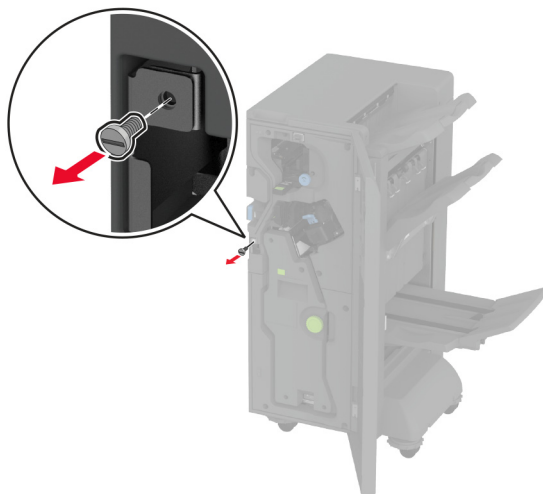

23 Attach the finisher to the printer.

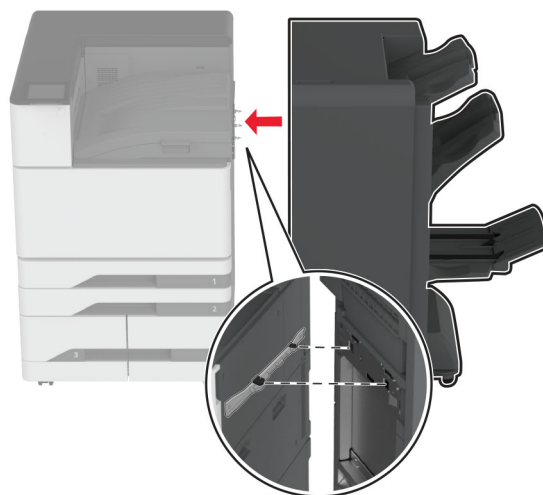

24 Open the finisher door, use the screw to secure the finisher to the printer, and then close the door.

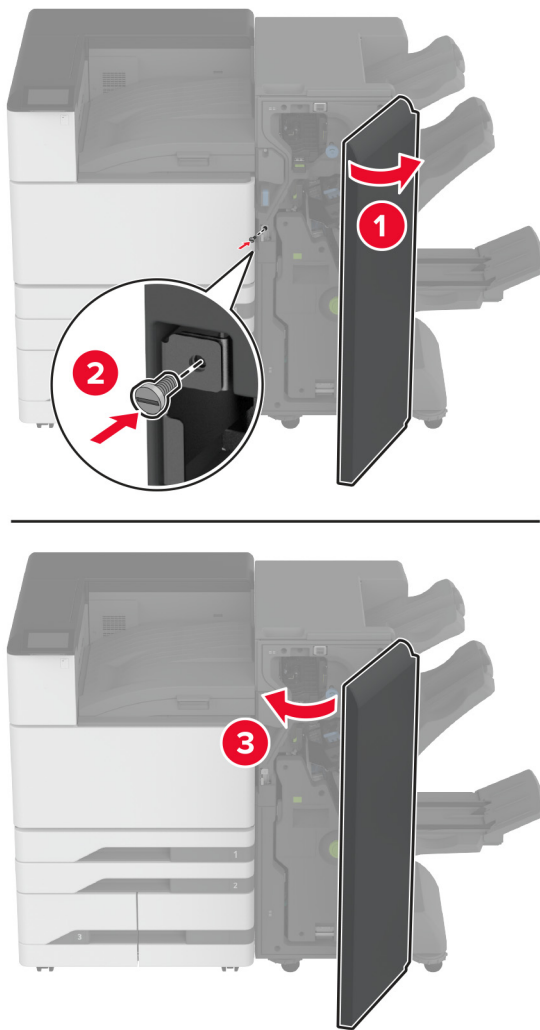

- 25** Rotate the side wheels of the finisher clockwise to make sure that all sides of the finisher have the same height.

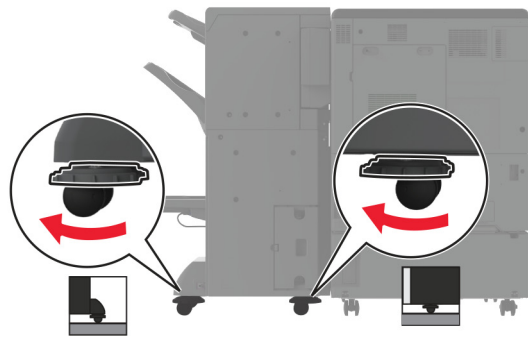
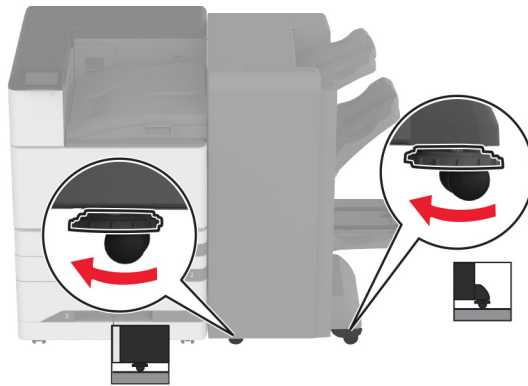

26 Connect the cables to the printer ports and finisher ports.

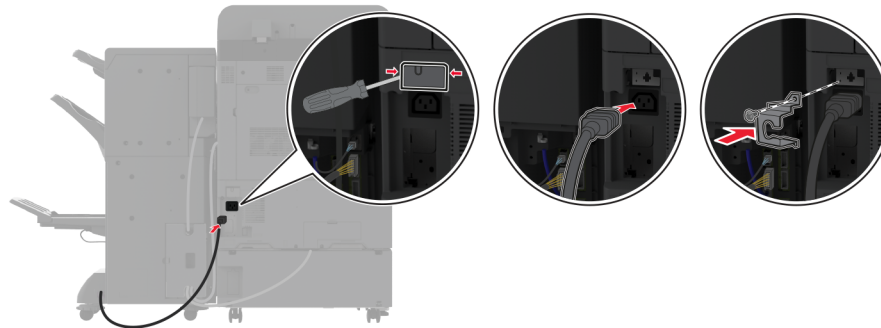
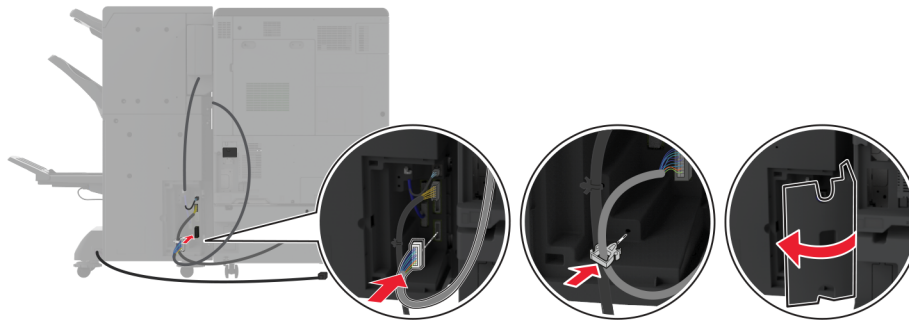
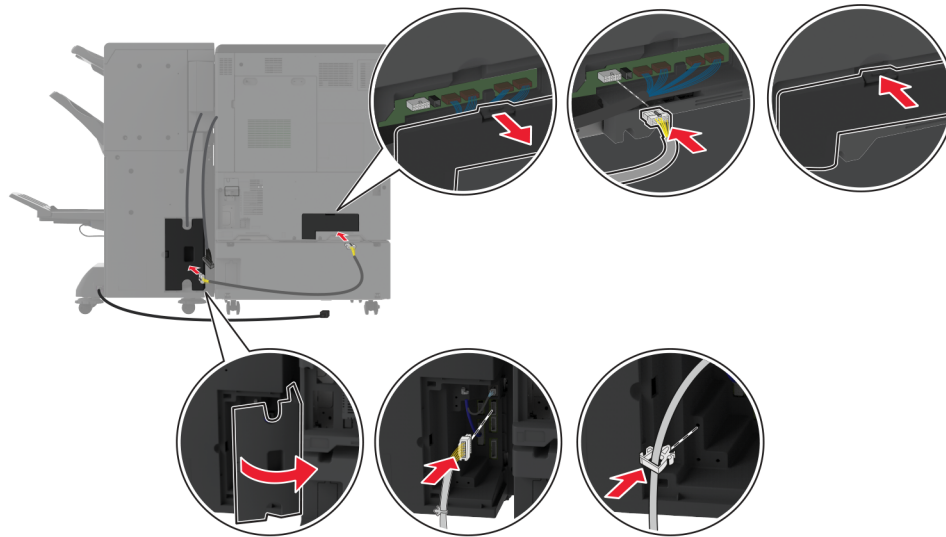

27 Connect the power cord to the printer, and then to the electrical outlet.

⚠ CAUTION—POTENTIAL INJURY: To avoid the risk of fire or electrical shock, connect the power cord to an appropriately rated and properly grounded electrical outlet that is near the product and easily accessible.

28 Turn on the printer.

Add the finisher in the print driver to make it available for print jobs. For more information, see [“Adding available options in the print driver” on page 61](#).

Installing the trifold/Z-fold finisher

⚠ CAUTION—SHOCK HAZARD: To avoid the risk of electrical shock, if you are accessing the controller board or installing optional hardware or memory devices sometime after setting up the printer, then turn the printer off, and unplug the power cord from the electrical outlet before continuing. If you have any other devices attached to the printer, then turn them off as well, and unplug any cables going into the printer.

Note: To install the trifold/Z-fold finisher, you must first install a booklet finisher.

- 1 Turn off the printer.

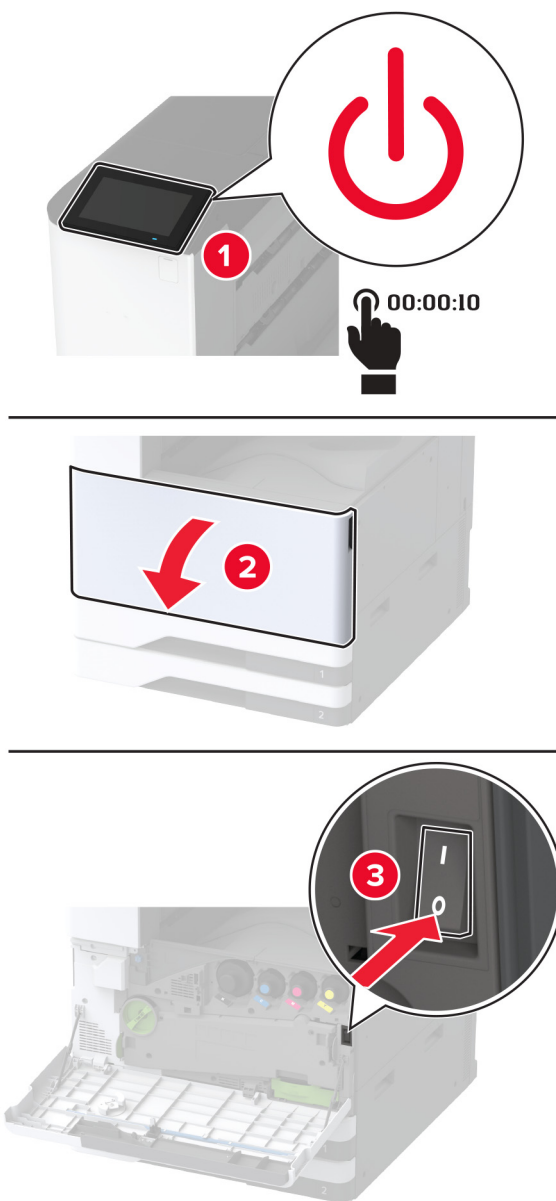

- 2 Unplug the power cord from the electrical outlet, and then from the printer.

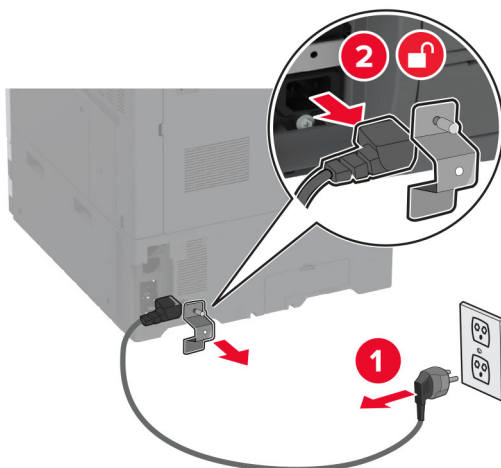

3 Unplug the booklet finisher cables from the printer.

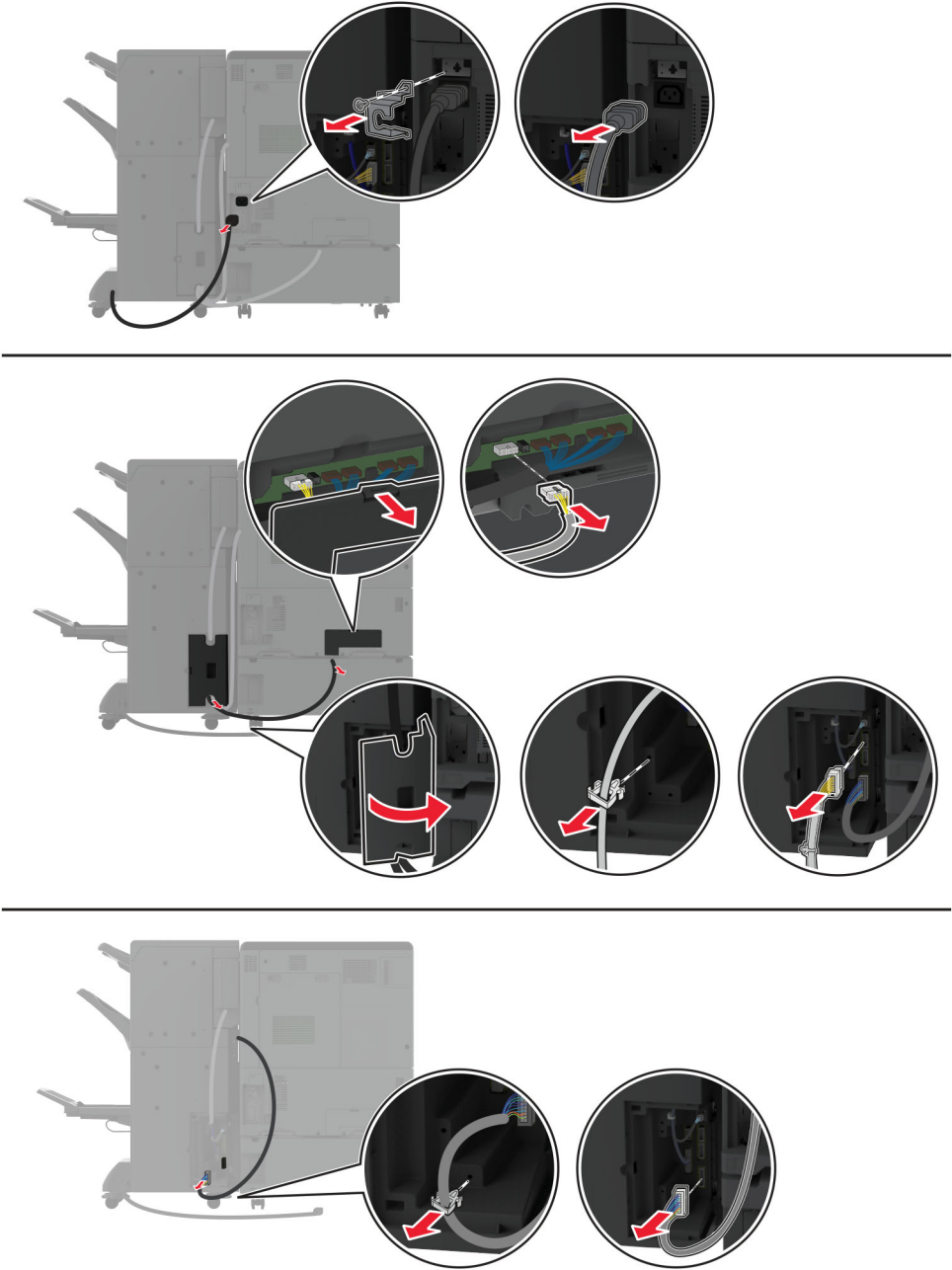

- 4** Open the booklet finisher door, use a flat-head screwdriver to remove the screw and metal bracket, and then close the door.

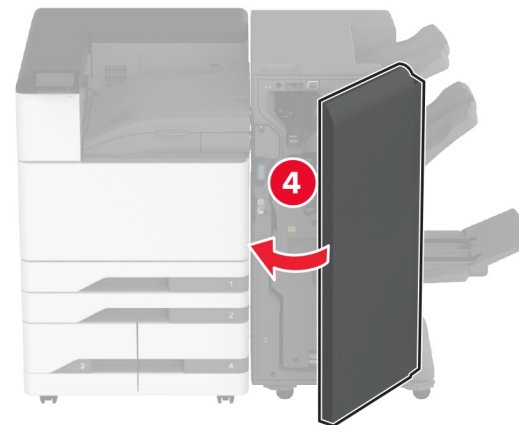
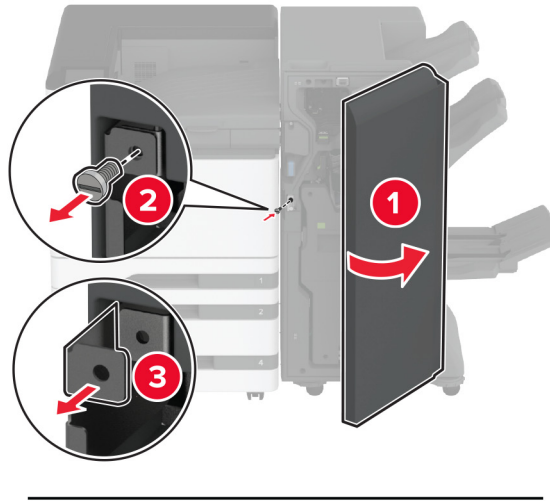

- 5** Remove the booklet finisher.

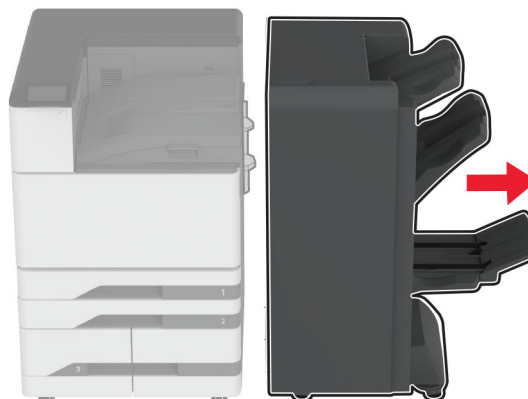

- 6** Unpack the trifold/Z-fold finisher, and then remove all the packing material.
- 7** Open the finisher door.

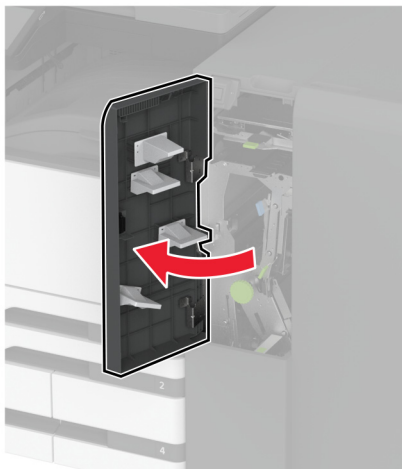

8 Remove the trifold bin, attach the screws to the bin, and then insert the bin.

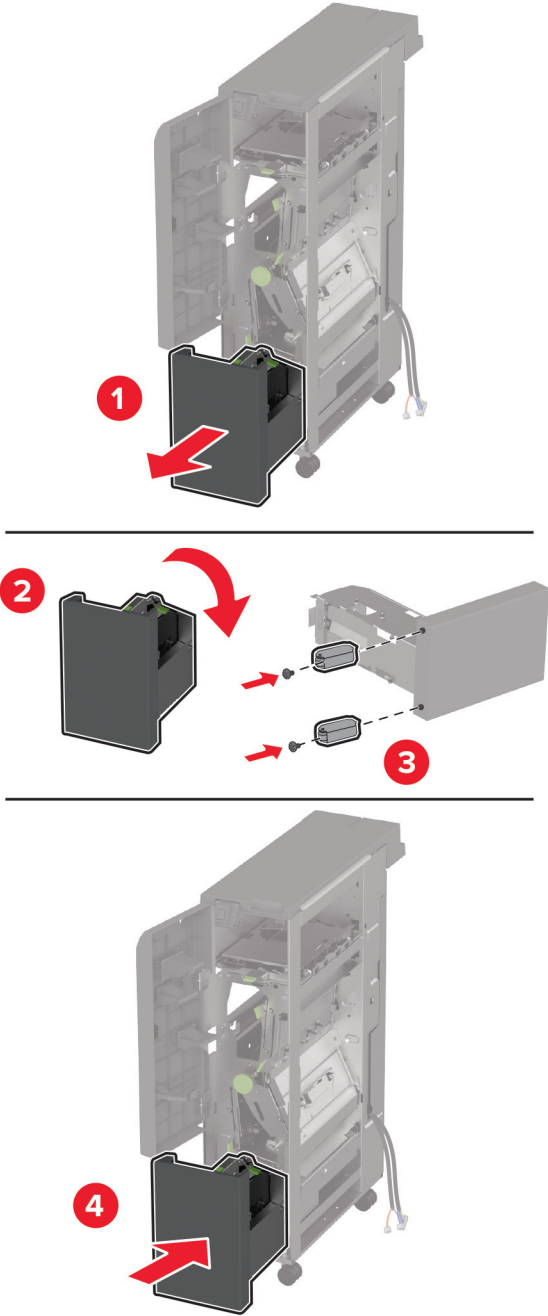

- 9 Using a flat-head screwdriver, attach the installation bracket for the trifold/Z-fold finisher, remove the screw, and then close the finisher door.

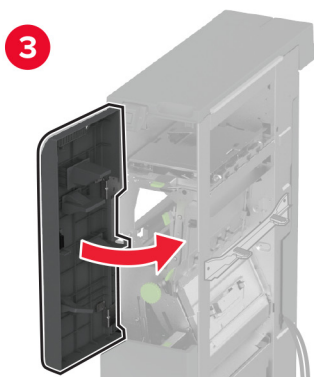
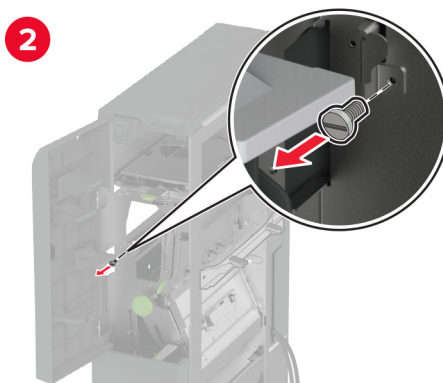
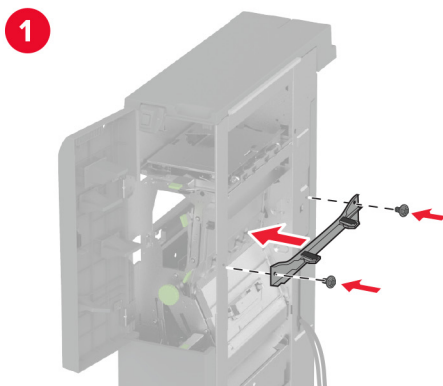

- 10** Attach the trifold/Z-fold finisher to the printer.

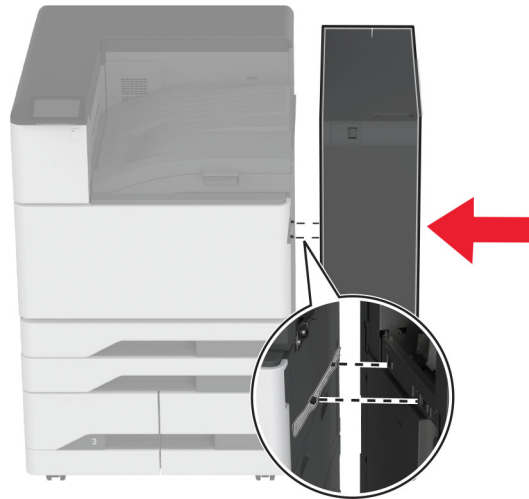

- 11** Open the trifold/Z-fold finisher door, use the screw to secure the finisher to the printer, and then close the finisher door.

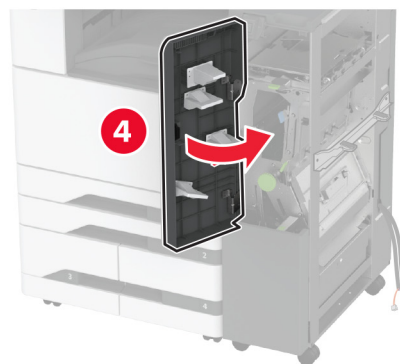
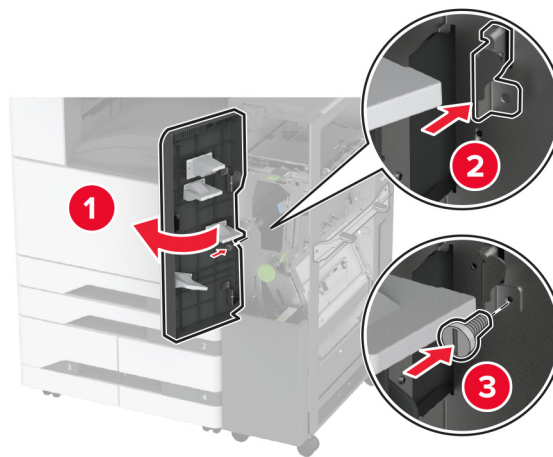

- 12 Remove the wrench, and then adjust the leveling screws to make sure that the front of the finisher has the same height as the printer.

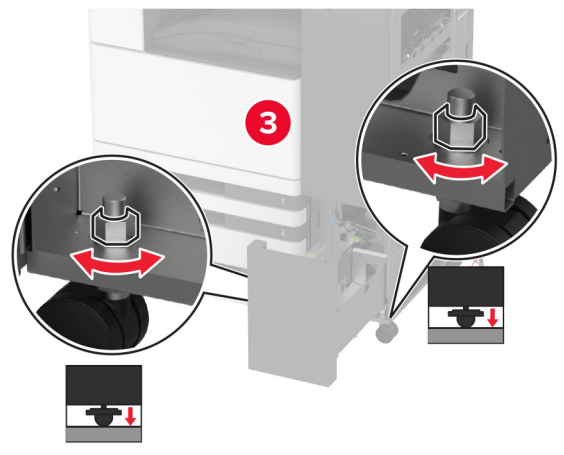
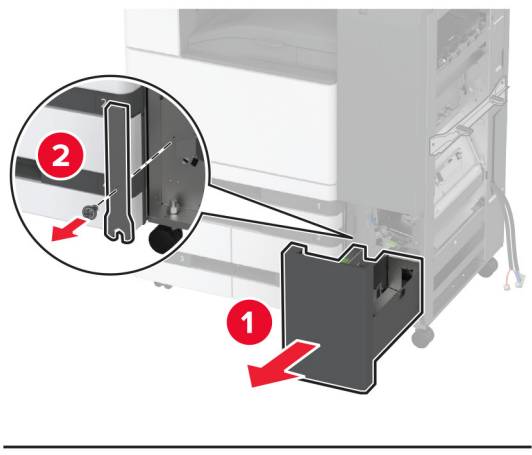

13 Adjust the leveling screws to make sure that the rear of the finisher has the same height as the printer.

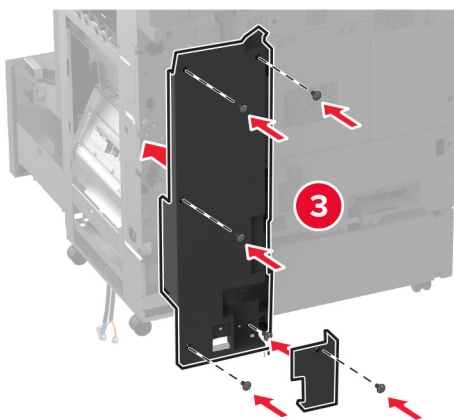
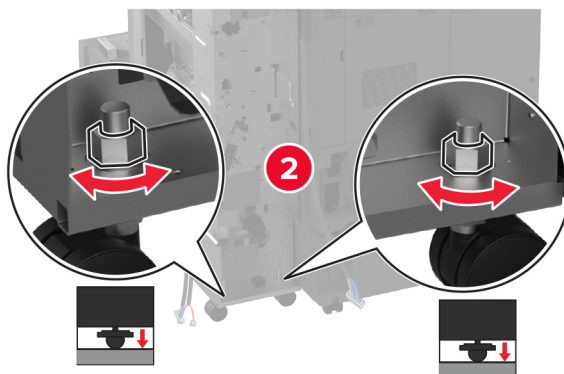
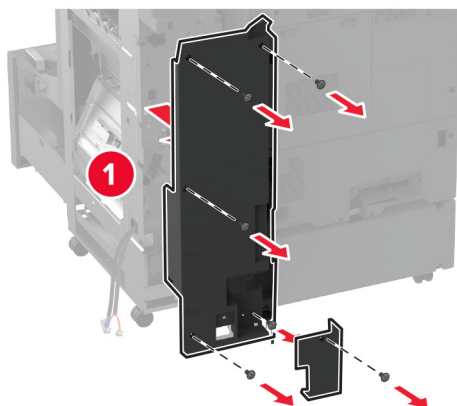

14 Attach the wrench to the trifold/Z-fold finisher.

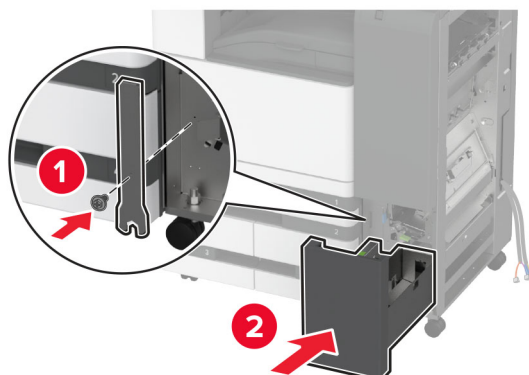

15 Attach the booklet finisher to the trifold/Z-fold finisher.

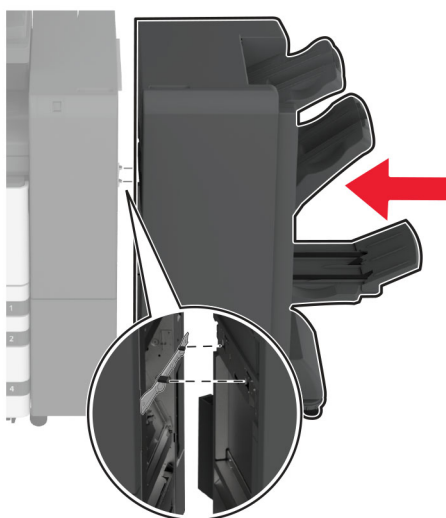

- 16** Open the booklet finisher door, use the screw to secure the booklet finisher to the trifold/Z-fold finisher, and then close the booklet finisher door.

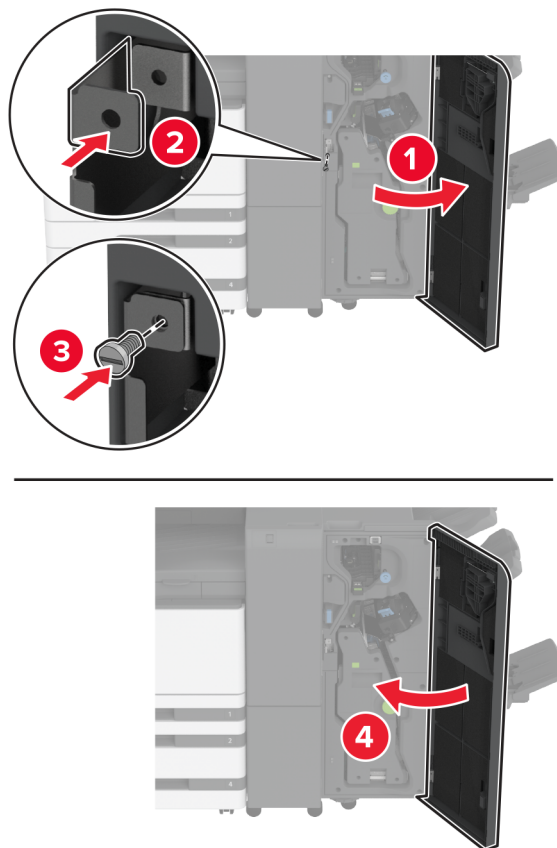

17 Adjust the leveling screws to make sure that all sides of the finisher have the same height.

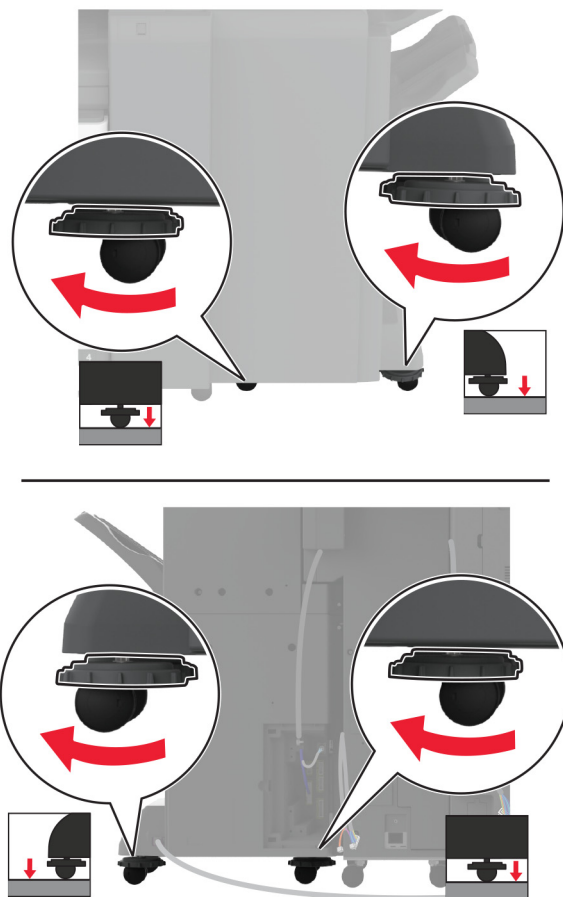

18 Connect the cables to the printer ports and finisher ports.

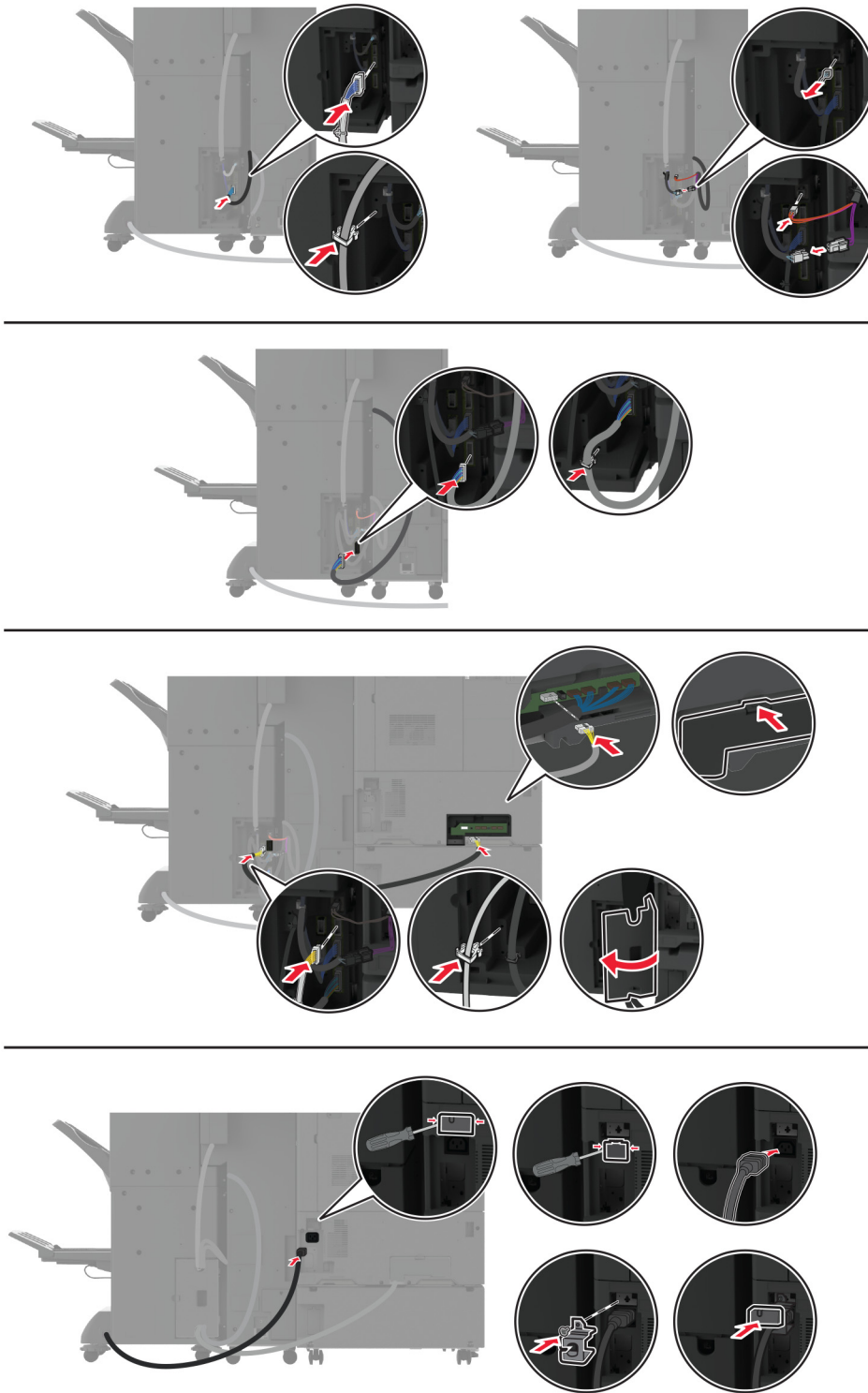

19 Connect the printer and finisher power cords to the printer and the finisher, and then to the electrical outlet.

⚠ CAUTION—POTENTIAL INJURY: To avoid the risk of fire or electrical shock, connect the power cord to an appropriately rated and properly grounded electrical outlet that is near the product and easily accessible.

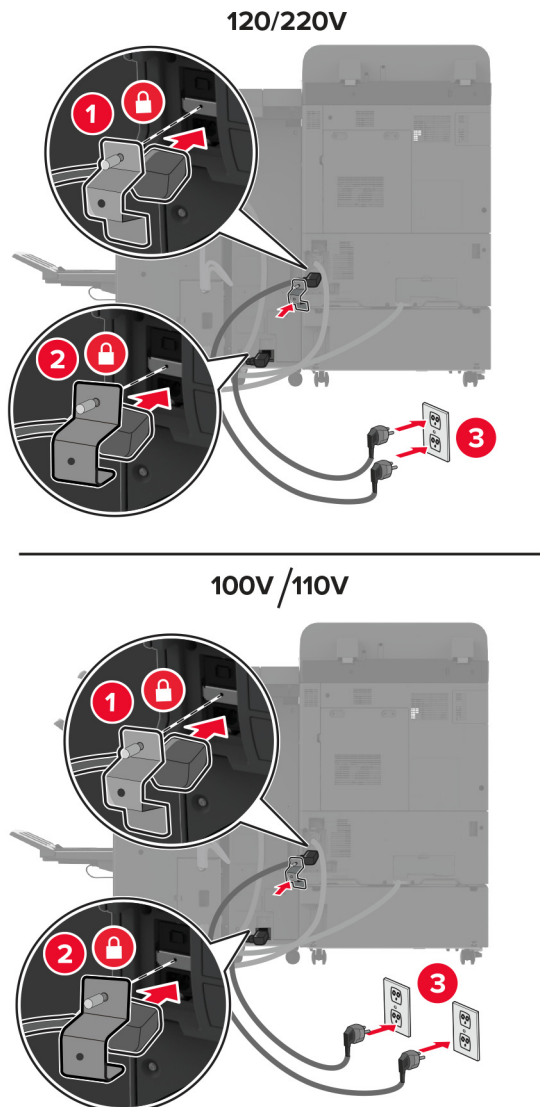

Note: If the outlet is 120 or 220 volts, then you may connect both power cords to the same outlet. If the outlet is 100 or 110 volts, then you must connect the power cords to separate outlets.

20 Turn on the printer.

Add the finisher in the print driver to make it available for print jobs. For more information, see [“Adding available options in the print driver” on page 61](#).

Installing a printer hard disk

⚠ CAUTION—SHOCK HAZARD: To avoid the risk of electrical shock, if you are accessing the controller board or installing optional hardware or memory devices sometime after setting up the printer, then turn the printer off, and unplug the power cord from the electrical outlet before continuing. If you have any other devices attached to the printer, then turn them off as well, and unplug any cables going into the printer.

- 1 Turn off the printer.

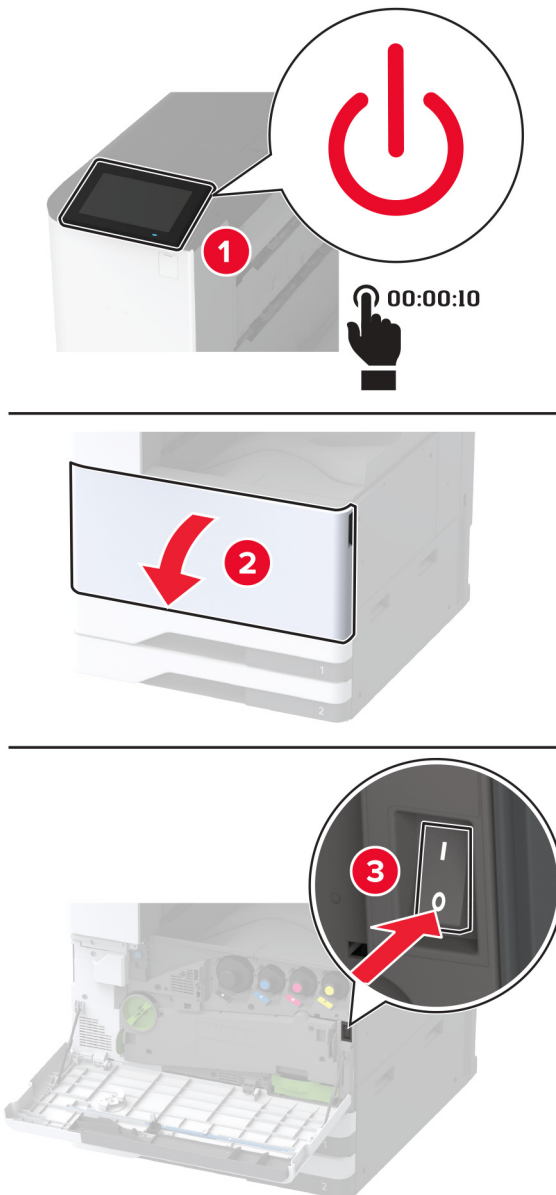

- 2 Remove the rear ports cover.

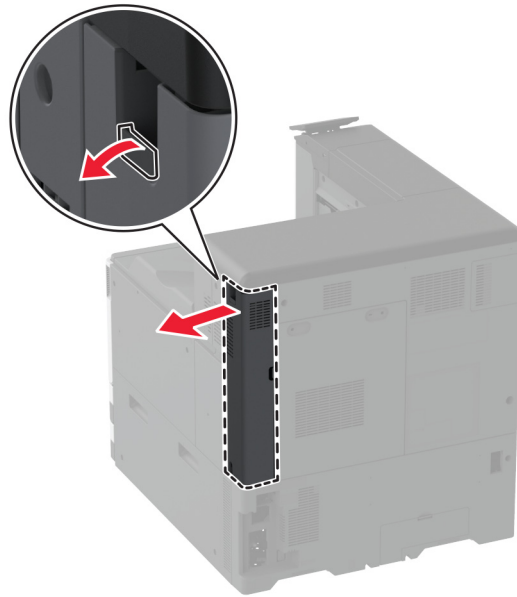

- 3 Unplug the power cord from the electrical outlet, and then from the printer.

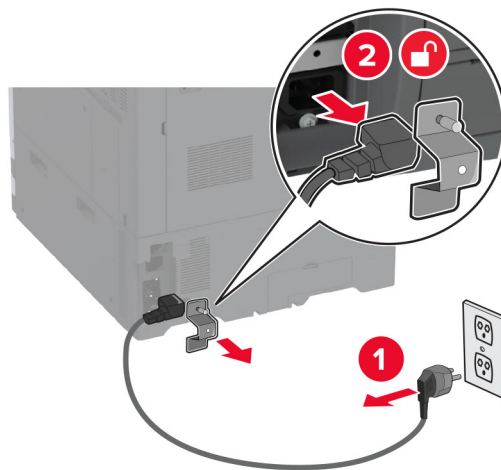

- 4 Using a flat-head screwdriver, remove the controller board access cover.

Warning—Potential Damage: Controller board electronic components are easily damaged by static electricity. Touch a metal surface on the printer before touching any controller board electronic components or connectors.

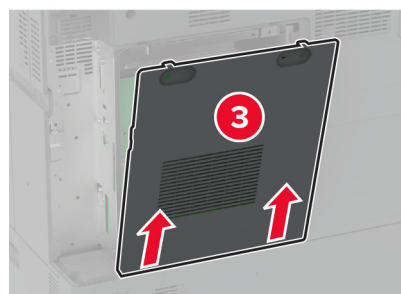
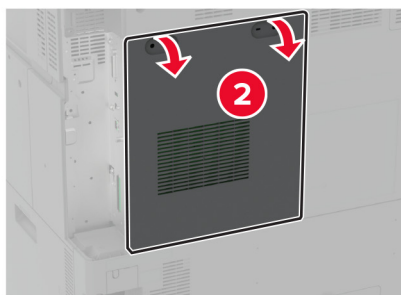
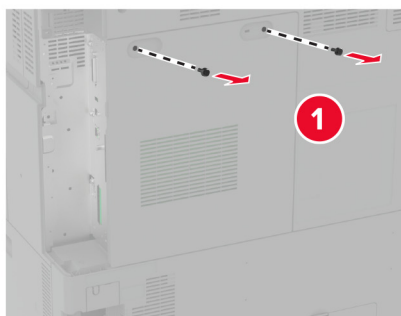

5 Unpack the hard disk.

Warning—Potential Damage: Do not touch or press the center of the hard disk.

6 Attach the hard disk to the controller board.

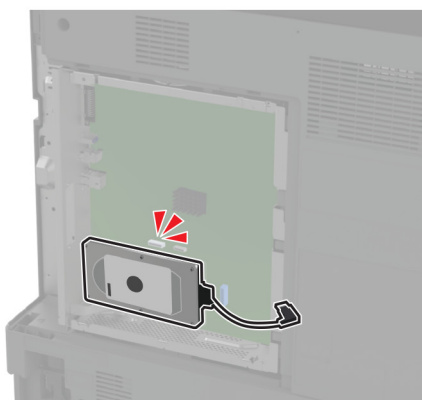
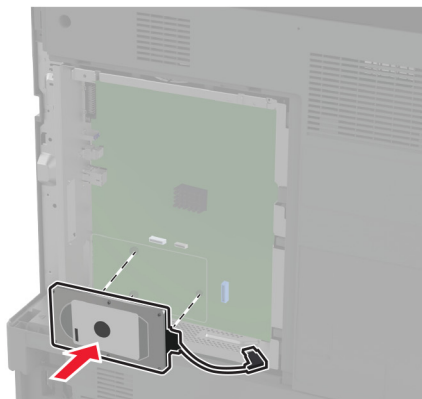

7 Attach the hard disk connector cable to the controller board.

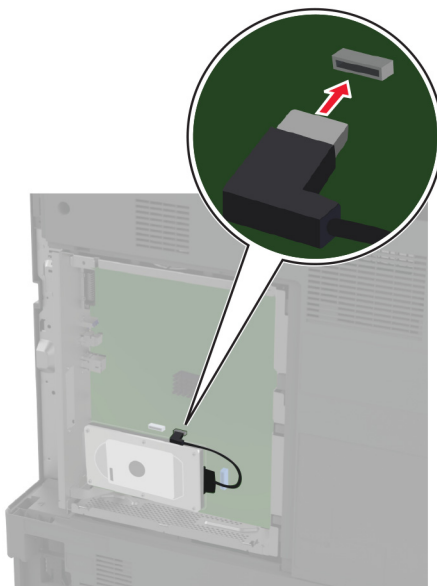

8 Attach the controller board access cover.

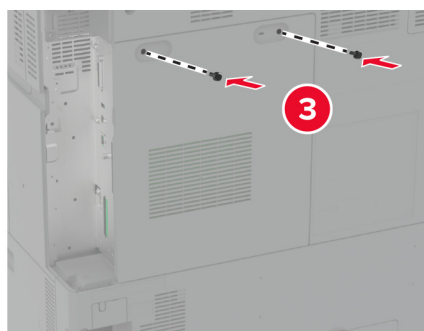
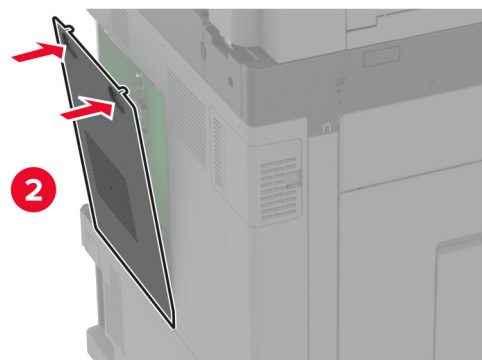
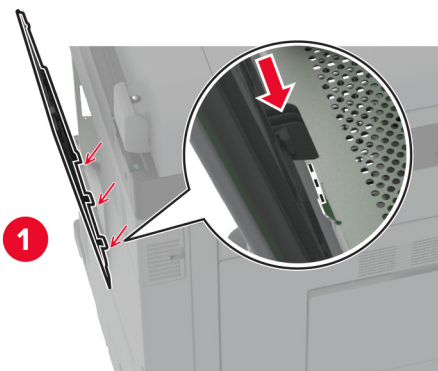

- 9 Attach the rear ports cover.

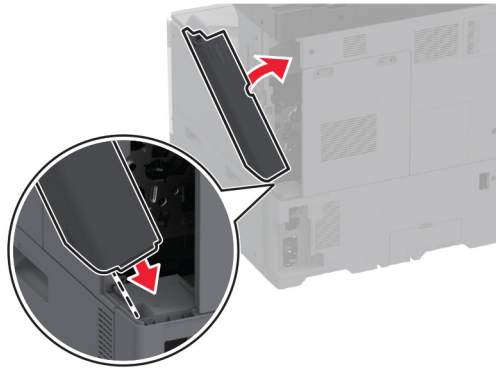

- 10 Connect the power cord to the electrical outlet, and then turn on the printer.

CAUTION—POTENTIAL INJURY: To avoid the risk of fire or electrical shock, connect the power cord to an appropriately rated and properly grounded electrical outlet that is near the product and easily accessible.

Installing the intelligent storage drive

CAUTION—SHOCK HAZARD: To avoid the risk of electrical shock, if you are accessing the controller board or installing optional hardware or memory devices sometime after setting up the printer, then turn the printer off, and unplug the power cord from the electrical outlet before continuing. If you have any other devices attached to the printer, then turn them off as well, and unplug any cables going into the printer.

- 1 Turn off the printer, and then unplug the power cord from the electrical outlet.
- 2 Using a flat-head screwdriver, remove the controller board access cover.

Warning—Potential Damage: Controller board electronic components are easily damaged by static electricity. Touch a metal surface on the printer before touching any controller board components or connectors.

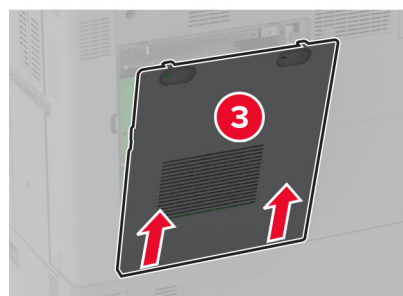
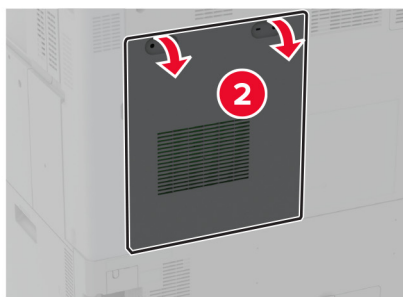
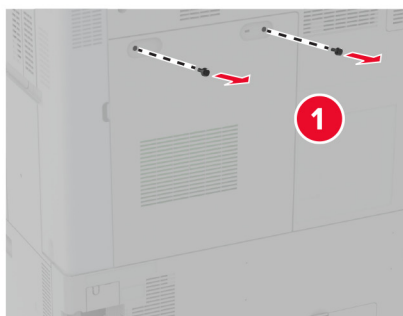

3 Unpack the intelligent storage drive (ISD).

Warning—Potential Damage: Avoid touching the connection points along the edge of the card.

4 Locate the ISD connector.

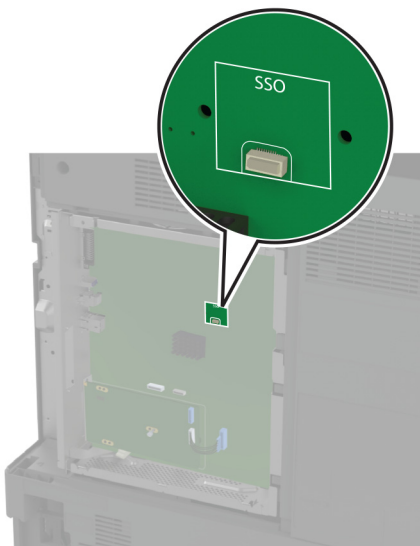

5 Insert the card to the ISD connector.

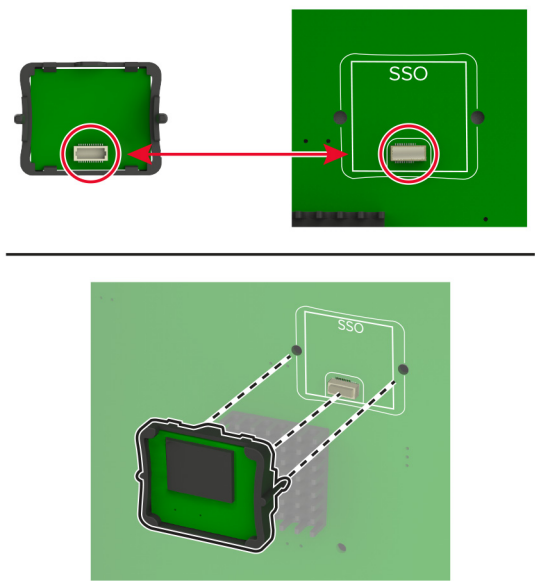

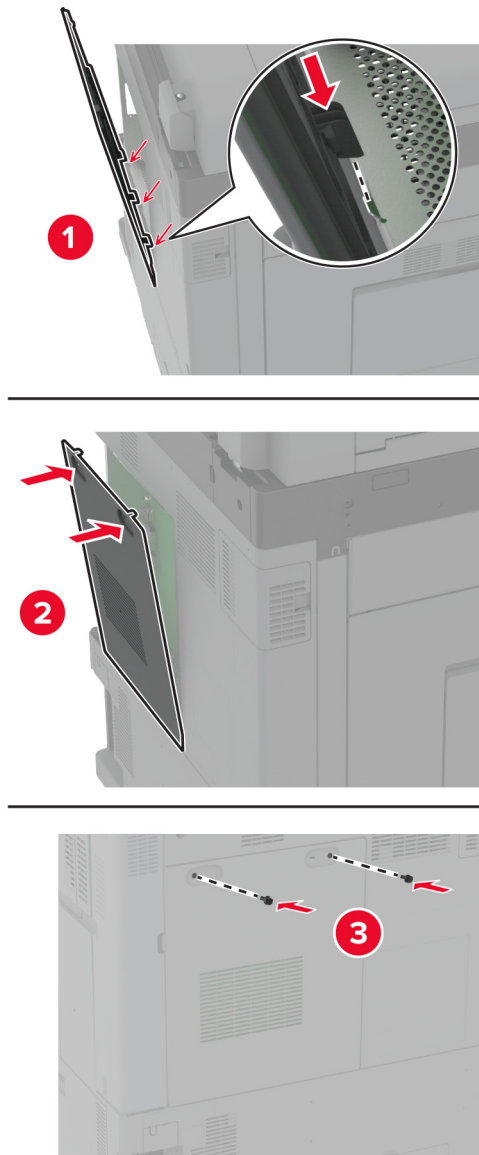
6 Attach the controller board access cover.**7** Connect the power cord to the electrical outlet, and then turn on the printer.

⚠ CAUTION—POTENTIAL INJURY: To avoid the risk of fire or electrical shock, connect the power cord to an appropriately rated and properly grounded electrical outlet that is near the product and easily accessible.

Installing wireless modules

Installing MarkNet N8372 Wireless Print Server

- 1 Turn off the printer.
- 2 Apply isopropyl alcohol to a damp, soft, lint-free cloth, and then wipe the surface around the USB port.
- 3 Install the wireless module.

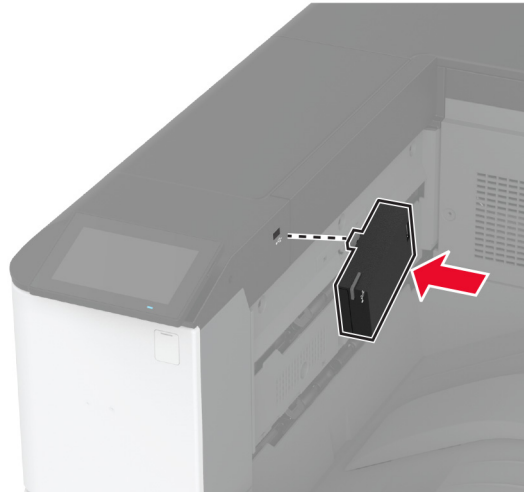

Notes:

- Apply firm pressure to make sure that the tape sticks to the surface of the printer.
 - Make sure that the printer surface is dry and free of condensed moisture.
 - The module is best bonded to the printer after 72 hours.
- 4 Check for a gap between the module and the printer, then attach the spacer module if necessary.

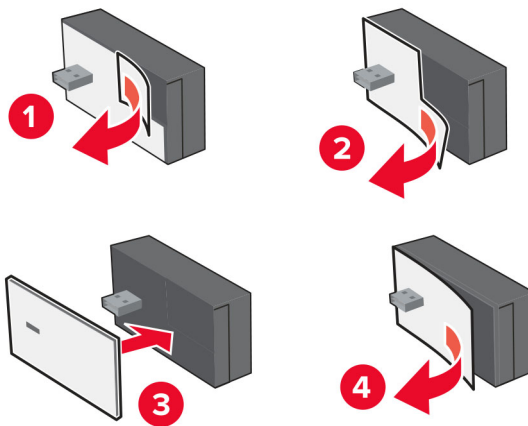

5 Attach the NFC card.

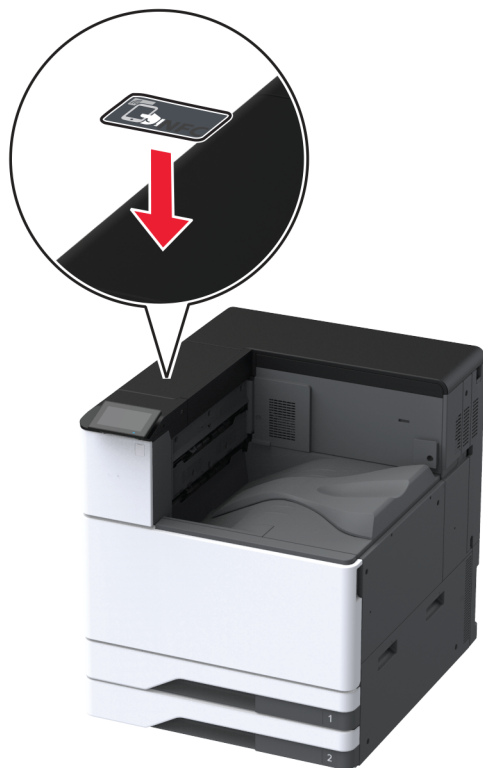

6 Turn on the printer.

Installing an internal solutions port

⚠ CAUTION—SHOCK HAZARD: To avoid the risk of electrical shock, if you are accessing the controller board or installing optional hardware or memory devices sometime after setting up the printer, then turn the printer off, and unplug the power cord from the electrical outlet before continuing. If you have any other devices attached to the printer, then turn them off as well, and unplug any cables going into the printer.

- 1 Turn off the printer, and then unplug the power cord from the electrical outlet.
- 2 Remove the rear ports cover.

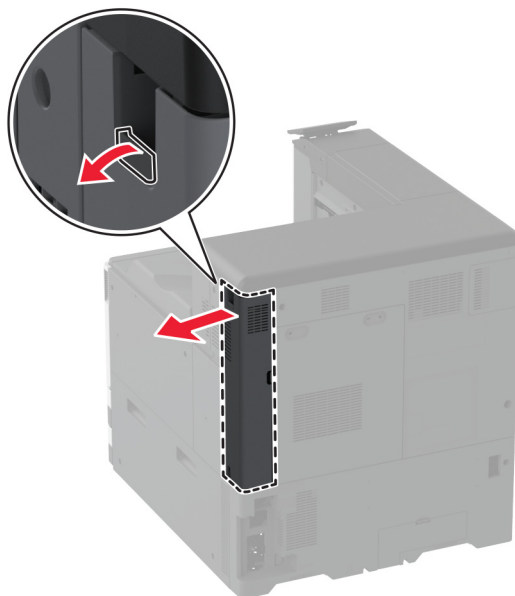

- 3 Using a flat-head screwdriver, remove the controller board access cover.

Warning—Potential Damage: Controller board electronic components are easily damaged by static electricity. Touch a metal surface on the printer before touching any controller board electronic components or connectors.

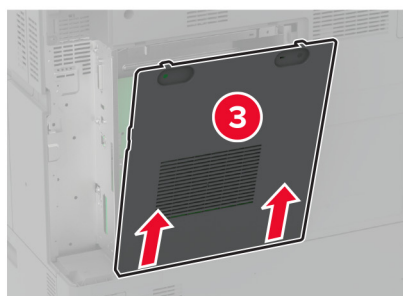
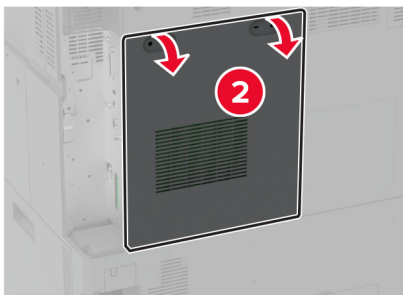
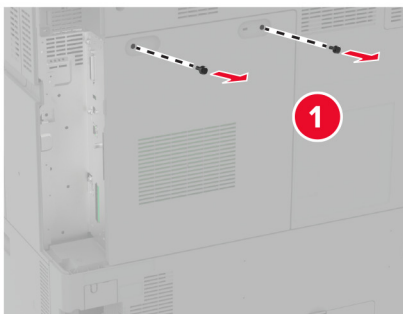

4 Remove the internal solutions port (ISP) cover.

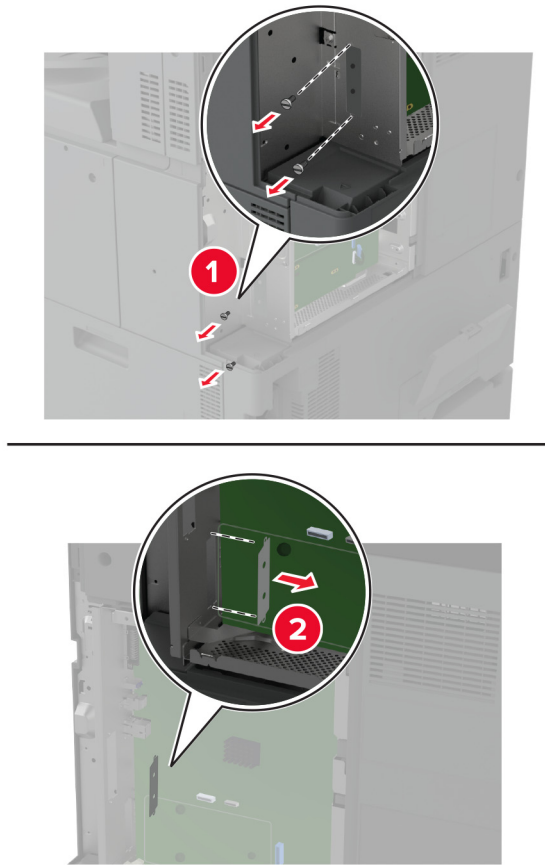

5 Unpack the ISP kit.

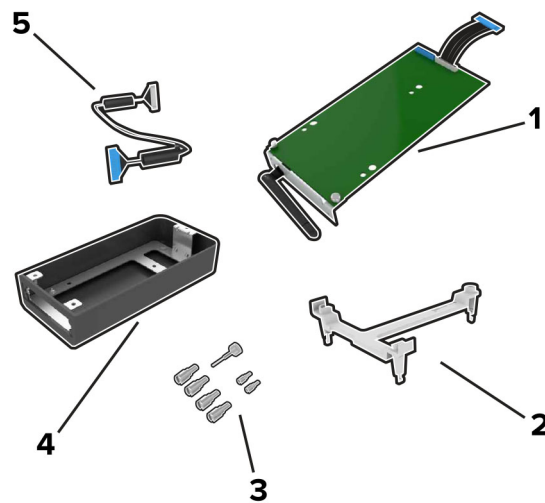

1	ISP
2	Mounting bracket

3	Thumbscrews
4	Housing Note: Not applicable for this printer model.
5	ISP extended cable

6 Attach the mounting bracket to the controller board.

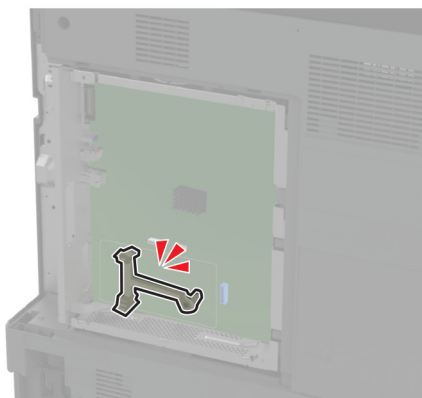
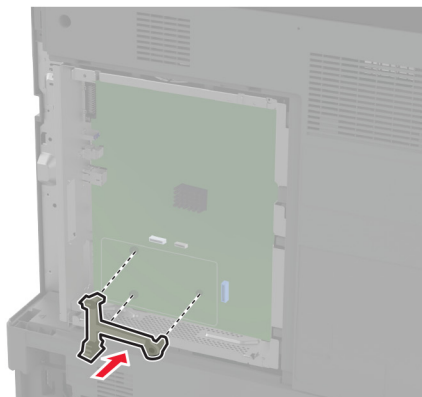

7 Attach the ISP to the mounting bracket.

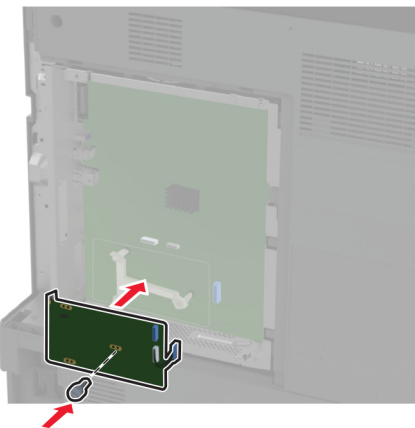

8 Connect the ISP extended cable to the ISP connector on the controller board.

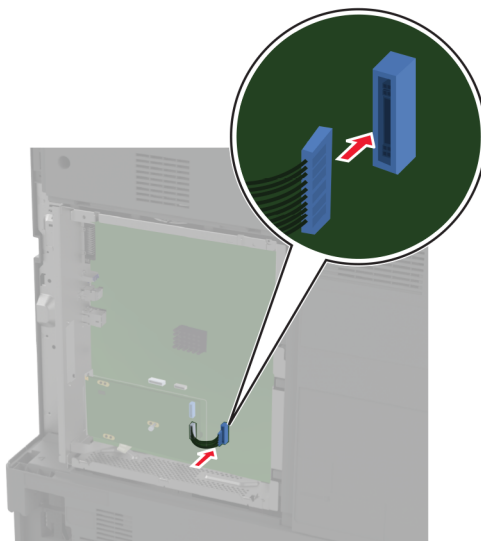

9 Secure the ISP to the printer.

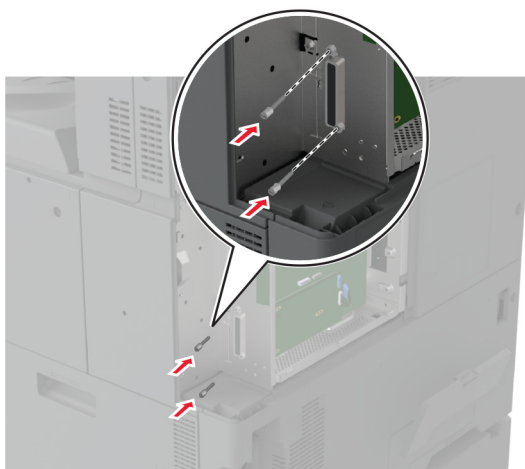

10 Attach the controller board access cover.

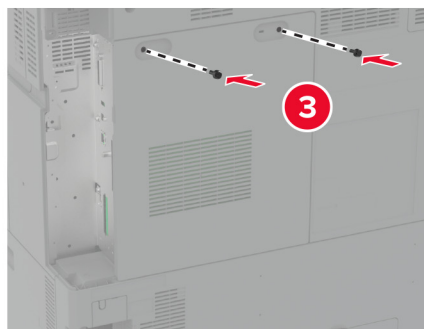
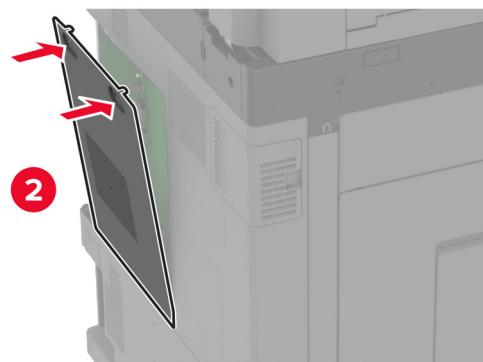
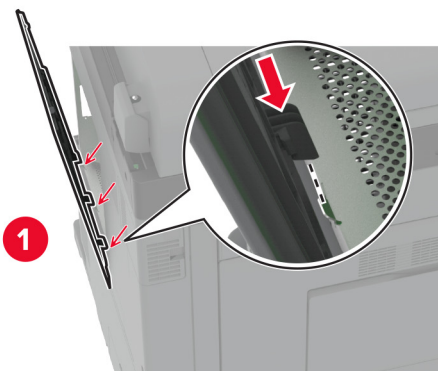

11 Attach the rear ports cover.

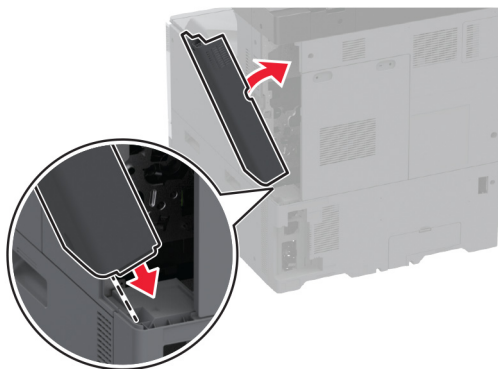

12 Connect the power cord to the electrical outlet, and then turn on the printer.

⚠ CAUTION—POTENTIAL INJURY: To avoid the risk of fire or electrical shock, connect the power cord to an appropriately rated and properly grounded electrical outlet that is near the product and easily accessible.

Changing the printer port settings after installing an internal solutions port

Notes:

- If the printer has a static IP address, then do not change the configuration.
- If the computers are configured to use the network name instead of an IP address, then do not change the configuration.
- If you are adding a wireless internal solutions port (ISP) to a printer previously configured for an Ethernet connection, then disconnect the printer from the Ethernet network.

For Windows users

- 1** Open the printers folder.
- 2** From the shortcut menu of the printer with the new ISP, open the printer properties.
- 3** Configure the port from the list.
- 4** Update the IP address.
- 5** Apply the changes.

For Macintosh users

- 1** From System Preferences in the Apple menu, navigate to the list of printers, and then select + > **IP**.
- 2** Type the IP address in the address field.
- 3** Apply the changes.

Networking

Connecting the printer to a Wi-Fi network

Make sure that Active Adapter is set to Auto. From the home screen, touch **Settings > Network/Ports > Network Overview > Active Adapter**.

Using the control panel

- 1 From the home screen, touch **Settings > Network/Ports > Wireless > Setup On Printer Panel > Choose Network**.
- 2 Select a Wi-Fi network, and then type the network password.

Note: For Wi-Fi-network-ready printer models, a prompt for Wi-Fi network setup appears during initial setup.

Using Lexmark Mobile Assistant

- 1 Depending on your mobile device, download the Lexmark Mobile Assistant application from either the Google Play™ store or App Store online store.
- 2 From the printer home screen, touch **Settings > Network/Ports > Wireless > Setup Using Mobile App > Printer ID**.
- 3 From your mobile device, launch the application, and then accept the Terms of Use.
Note: If necessary, grant permissions.
- 4 Tap **Connect to Printer > Go to Wi-Fi Settings**.
- 5 Connect your mobile device to the printer wireless network.
- 6 Return to the application, and then tap **Setup Wi-Fi Connection**
- 7 Select a Wi-Fi network, and then type the network password.
- 8 Tap **Done**.

Connecting the printer to a wireless network using Wi-Fi Protected Setup (WPS)

Before you begin, make sure that:

- The access point (wireless router) is WPS-certified or WPS-compatible. For more information, see the documentation that came with your access point.
- A wireless network adapter is installed in your printer. For more information, see the instructions that came with the adapter.
- Active Adapter is set to Auto. From the home screen, touch **Settings > Network/Ports > Network Overview > Active Adapter**.

Using the Push Button method

- 1 From the home screen, touch **Settings > Network/Ports > Wireless > Wi-Fi Protected Setup > Start Push Button Method**.
- 2 Follow the instructions on the display.

Using the personal identification number (PIN) method

- 1 From the home screen, touch **Settings > Network/Ports > Wireless > Wi-Fi Protected Setup > Start PIN Method**.
- 2 Copy the eight-digit WPS PIN.
- 3 Open a web browser, and then type the IP address of your access point in the address field.

Notes:

- To know the IP address, see the documentation that came with your access point.
 - If you are using a proxy server, then temporarily disable it to load the web page correctly.
- 4 Access the WPS settings. For more information, see the documentation that came with your access point.
 - 5 Enter the eight-digit PIN, and then save the changes.

Configuring Wi-Fi Direct

Wi-Fi Direct® is a Wi-Fi-based peer-to-peer technology that allows wireless devices to connect directly to a Wi-Fi Direct-enabled printer without using an access point (wireless router).

- 1 From the home screen, touch **Settings > Network/Ports > Wi-Fi Direct**.
- 2 Configure the settings.
 - **Enable Wi-Fi Direct**—Enables the printer to broadcast its own Wi-Fi Direct network.
 - **Wi-Fi Direct Name**—Assigns a name for the Wi-Fi Direct network.
 - **Wi-Fi Direct Password**—Assigns the password for negotiating the wireless security when using the peer-to-peer connection.
 - **Show Password on Setup Page**—Shows the password on the Network Setup Page.
 - **Auto-Accept Push Button Requests**—Lets the printer accept connection requests automatically.

Note: Accepting push-button requests automatically is not secured.

Notes:

- By default, the Wi-Fi Direct network password is not visible on the printer display. To show the password, enable the password peek icon. From the home screen, touch **Settings > Security > Miscellaneous > Enable Password/PIN Reveal**.
- To know the password of the Wi-Fi Direct network without showing it on the printer display, from the home screen touch **Settings > Reports > Network > Network Setup Page**.

Connecting a mobile device to the printer

Before connecting your mobile device, make sure that Wi-Fi Direct has been configured. For more information, see [“Configuring Wi-Fi Direct” on page 161](#).

Connecting using Wi-Fi Direct

Note: These instructions apply only to Android mobile devices.

- 1 From the mobile device, go to the settings menu.
- 2 Enable **Wi-Fi**, and then tap **Wi-Fi Direct**.
- 3 Select the printer Wi-Fi Direct name.
- 4 Confirm the connection on the printer control panel.

Connecting using Wi-Fi

- 1 From the mobile device, go to the settings menu.
- 2 Tap **Wi-Fi**, and then select the printer Wi-Fi Direct name.

Note: The string DIRECT-xy (where x and y are two random characters) is added before the Wi-Fi Direct name.

- 3 Enter the Wi-Fi Direct password.

Connecting a computer to the printer

Before connecting your computer, make sure that Wi-Fi Direct has been configured. For more information, see [“Configuring Wi-Fi Direct” on page 161](#).

For Windows users

- 1 Open **Printers & scanners**, and then click **Add a printer or scanner**.
- 2 Click **Show Wi-Fi Direct printers**, and then select the printer Wi-Fi Direct name.
- 3 From the printer display, take note of the eight-digit PIN of the printer.
- 4 Enter the PIN on the computer.

Note: If the print driver is not already installed, then Windows downloads the appropriate driver.

For Macintosh users

- 1 Click the wireless icon, and then select the printer Wi-Fi Direct name.

Note: The string DIRECT-xy (where x and y are two random characters) is added before the Wi-Fi Direct name.

- 2 Type the Wi-Fi Direct password.

Note: Switch your computer back to its previous network after disconnecting from the Wi-Fi Direct network.

Deactivating the Wi-Fi network

- 1 From the home screen, touch **Settings > Network/Ports > Network Overview > Active Adapter > Standard Network**.
- 2 Follow the instructions on the display.

Checking the printer connectivity

- 1 From the home screen, touch **Settings > Reports > Network > Network Setup Page**.
- 2 Check the first section of the network setup page, and confirm that the status is connected.
If the status is not connected, then the LAN drop may be inactive, or the network cable may be malfunctioning. Contact your administrator for assistance.

Setting up serial printing (Windows only)

- 1 Set the parameters in the printer.
 - a From the control panel, navigate to the menu for the port settings.
 - b Locate the menu for the serial port settings, and then adjust the settings, if necessary.
 - c Apply the changes.
- 2 From your computer, open the printers folder, and then select your printer.
- 3 Open the printer properties, and then select the COM port from the list.
- 4 Set the COM port parameters in Device Manager.

Notes:

- Serial printing reduces printing speed.
- Make sure that the serial cable is connected to the serial port on your printer.

Secure the printer

Locating the security slot

The printer is equipped with a security lock feature. Attach a security lock compatible with most laptop computers in the location shown to secure the printer in place.

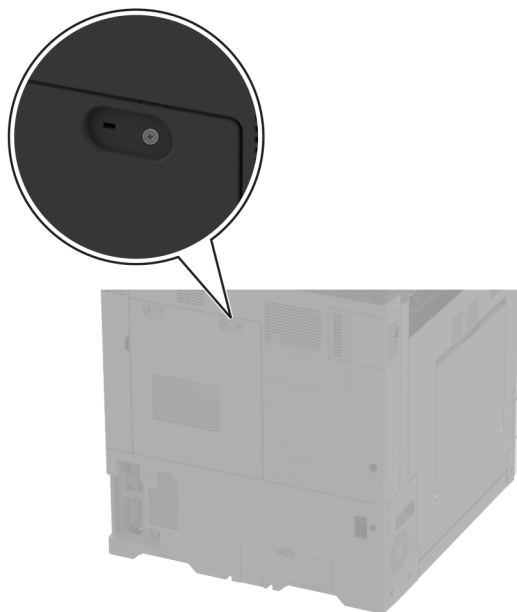

Erasing printer memory

To erase volatile memory or buffered data in your printer, turn off the printer.

To erase nonvolatile memory, device and network settings, security settings, and embedded solutions, do the following:

- 1 From the home screen, touch **Settings > Device > Maintenance > Out of Service Erase**.
- 2 Touch the **Sanitize all information on nonvolatile memory** check box, and then touch **ERASE**.
- 3 Touch **Start initial setup wizard** or **Leave printer offline**, and then touch **Next**.
- 4 Start the operation.

Note: This process also destroys the encryption key that is used to protect user data. Destroying the encryption key makes the data irrecoverable.

Erasing printer storage drive

- 1 From the home screen, touch **Settings** > **Device** > **Maintenance** > **Out of Service Erase**.
- 2 Depending on the storage drive that is installed on your printer, do either of the following:
 - For hard disk, touch the **Sanitize all information on hard disk** check box, touch **ERASE**, and then select a method to erase data.

Note: The process to sanitize the hard disk can take from several minutes to more than an hour, making the printer unavailable for other tasks.
 - For intelligent storage drive (ISD), touch **Erase Intelligent Storage Drive**, and then touch **ERASE** to erase all user data.
- 3 Start the operation.

Restoring factory default settings

- 1 From the home screen, touch **Settings** > **Device** > **Restore Factory Defaults**.
- 2 Touch **Restore Settings** > select the settings that you want to restore > **RESTORE**.
- 3 Start the operation.

Statement of Volatility

Type of memory	Description
Volatile memory	The printer uses standard random access memory (RAM) to buffer temporarily user data during simple print and copy jobs.
Nonvolatile memory	The printer may use two forms of non-volatile memory: EEPROM and NAND (flash memory). Both types store the operating system, printer settings, and network information. They also store scanner and bookmark settings and embedded solutions.
Hard disk storage drive	Some printers may have a hard disk drive installed. The printer hard disk is designed for printer-specific functionality. The hard disk lets the printer retain buffered user data from complex print jobs, form data, and font data.
Intelligent storage drive (ISD)	Some printers may have an ISD installed. ISD uses non-volatile flash memory to store user data from complex print jobs, form data, and font data.

Erase the content of any installed printer memory in the following circumstances:

- The printer is decommissioned.
- The printer hard disk or ISD is replaced.
- The printer is moved to a different department or location.
- The printer is serviced by someone from outside your organization.

- The printer is removed from your premises for service.
- The printer is sold to another organization.

Note: To dispose a storage drive, follow the policies and procedures of your organization.

Print

Printing from a computer

Note: For labels, card stock, and envelopes, set the paper size and type in the printer before printing the document.

- 1 From the document that you are trying to print, open the Print dialog.
- 2 If necessary, adjust the settings.
- 3 Print the document.

Printing from a mobile device

Printing from a mobile device using Lexmark Mobile Print

Lexmark™ Mobile Print allows you to send documents and images directly to a supported Lexmark printer.

- 1 Open the document, and then send or share the document to Lexmark Mobile Print.

Note: Some third-party applications may not support the send or share feature. For more information, see the documentation that came with the application.

- 2 Select a printer.
- 3 Print the document.

Printing from a mobile device using Lexmark Print

Lexmark Print is a mobile printing solution for mobile devices running on Android™ version 6.0 or later. It lets you send documents and images to network-connected printers and print management servers.

Notes:

- Make sure that you download the Lexmark Print application from the Google Play store and enable it in the mobile device.
- Make sure that the printer and the mobile device are connected to the same network.

- 1 From your mobile device, select a document from the file manager.
- 2 Send or share the document to Lexmark Print.



Note: Some third-party applications may not support the send or share feature. For more information, see the documentation that came with the application.

- 3 Select a printer, and then adjust the settings, if necessary.
- 4 Print the document.

Printing from a mobile device using Mopria Print Service

Mopria® Print Service is a mobile printing solution for mobile devices running on Android version 5.0 or later. It allows you to print directly to any Mopria-certified printer.

Note: Make sure that you download the Mopria Print Service application from the Google Play store and enable it in the mobile device.

- 1 From your Android mobile device, launch a compatible application or select a document from your file manager.
- 2 Tap  > **Print**.
- 3 Select a printer, and then adjust the settings, if necessary.
- 4 Tap .

Printing from a mobile device using AirPrint

The AirPrint software feature is a mobile printing solution that allows you to print directly from Apple devices to an AirPrint-certified printer.

Notes:



- Make sure that the Apple device and the printer are connected to the same network. If the network has multiple wireless hubs, then make sure that both devices are connected to the same subnet.
- This application is supported only in some Apple devices.

- 1 From your mobile device, select a document from your file manager or launch a compatible application.
- 2 Tap  > **Print**.
- 3 Select a printer, and then adjust the settings, if necessary.
- 4 Print the document.

Printing from a mobile device using Wi-Fi Direct®

Wi-Fi Direct® is a printing service that lets you print to any Wi-Fi Direct-ready printer.

Note: Make sure that the mobile device is connected to the printer wireless network. For more information, see [“Connecting a mobile device to the printer” on page 162](#).

- 1 From your mobile device, launch a compatible application or select a document from your file manager.
- 2 Depending on your mobile device, do one of the following:
 - Tap  > **Print**.
 - Tap  > **Print**.
 - Tap **...** > **Print**.
- 3 Select a printer, and then adjust the settings, if necessary.
- 4 Print the document.

Printing a booklet

Note: Booklet printing is supported on any paper size that is supported by two-sided printing.

For Windows users

- 1 With a document open, click **File > Print**.
- 2 Select a printer, and then click **Properties, Preferences, Options, or Setup**.
- 3 Click **Layout**, and then in the Page Layouts section, select **Booklet**.

Note: If necessary, configure the booklet settings.

- 4 Click **OK** or **Print**.

For Macintosh users

- 1 With a document open, choose **File > Print**.
- 2 Select a printer, and then in the Presets menu, choose **Advanced Layout > Booklet**.
- 3 Click **Print**.

Printing from a flash drive

- 1 Insert the flash drive.

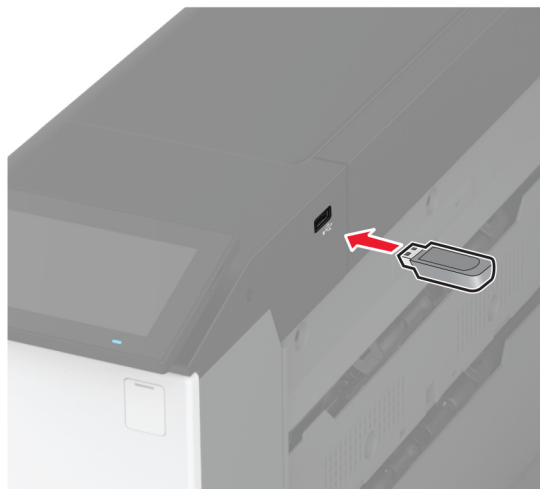

Notes:

- If you insert the flash drive when an error message appears, then the printer ignores the flash drive.
- If you insert the flash drive while the printer is processing other print jobs, then **Busy** appears on the display.

- 2 From the display, touch the document that you want to print.

If necessary, configure the print settings.

- 3 Print the document.

To print another document, touch **USB Drive**.

Warning—Potential Damage: To avoid loss of data or printer malfunction, do not touch the flash drive or the printer in the area shown while actively printing, reading, or writing from the memory device.



Supported flash drives and file types

Flash drives

- Lexar JumpDrive S70 (16GB and 32GB)
- SanDisk Cruzer Micro (16GB and 32GB)
- PNY Attaché (16GB and 32GB)

Notes:

- The printer supports high-speed flash drives with full-speed standard.
- Flash drives must support the File Allocation Table (FAT) system.

File types

Documents	Images
<ul style="list-style-type: none"> • PDF (version 1.7 or earlier) • Microsoft file formats (DOC, DOCX, XLS, XLSX, PPT, PPTX) 	<ul style="list-style-type: none"> • JPEG or JPG • TIFF or TIF • GIF • BMP • PNG • PCX • DCX

Configuring confidential jobs

- 1 From the home screen, touch **Settings** > **Security** > **Confidential Print Setup**.
- 2 Configure the settings.

Setting	Description
Max Invalid PIN	Set the limit for entering an invalid PIN. Note: When the limit is reached, the print jobs for that user name are deleted.
Confidential Job Expiration	Set an individual expiration time for each held job before it is automatically deleted from the printer memory, hard disk, or intelligent storage drive. Note: A held job is either Confidential, Repeat, Reserve, or Verify.
Repeat Job Expiration	Set the expiration time for print jobs that you want to repeat.
Verify Job Expiration	Set the expiration time for printing a copy of a job for you to check its quality before printing the remaining copies.
Reserve Job Expiration	Set the expiration time for jobs that you want to store in the printer for printing later.
Require All Jobs to be Held	Set the printer to hold all print jobs.
Keep duplicate documents	Set the printer to keep all documents with the same file name.

Printing confidential and other held jobs

For Windows users

- 1 With a document open, click **File** > **Print**.
- 2 Select a printer, and then click **Properties, Preferences, Options, or Setup**.
- 3 Click **Print and Hold**.
- 4 Select **Use Print and Hold**, and then assign a user name.
- 5 Select the print job type (Confidential, Repeat, Reserve, or Verify).
If you select **Confidential**, then secure the print job with a personal identification number (PIN).
- 6 Click **OK** or **Print**.
- 7 From the printer home screen, release the print job.
 - For confidential print jobs, touch **Held jobs** > select your user name > **Confidential** > enter the PIN > select the print job > configure the settings > **Print**.
 - For other print jobs, touch **Held jobs** > select your user name > select the print job > configure the settings > **Print**.

For Macintosh users

Using AirPrint

- 1 With a document open, choose **File > Print**.
- 2 Select a printer, and then from the drop-down menu following the Orientation menu, choose **PIN Printing**.
- 3 Enable **Print with PIN**, and then enter a four-digit PIN.
- 4 Click **Print**.
- 5 From the printer home screen, release the print job. Touch **Held jobs** > select your computer name > **Confidential** > enter the PIN > select the print job > **Print**.

Using the print driver

- 1 With a document open, choose **File > Print**.
- 2 Select a printer, and then from the drop-down menu following the Orientation menu, choose **Print and Hold**.
- 3 Choose **Confidential Print**, and then enter a four-digit PIN.
- 4 Click **Print**.
- 5 From the printer home screen, release the print job. Touch **Held jobs** > select your computer name > **Confidential** > select the print job > enter the PIN > **Print**.

Printing a font sample list

- 1 From the home screen, touch **Settings > Reports > Print > Print Fonts**.
- 2 Touch **PCL Fonts** or **PS Fonts**.

Printing a directory list

From the home screen, touch **Settings > Reports > Print > Print Directory**.

Placing separator sheets between copies

- 1 From the home screen, touch **Settings > Print > Layout > Separator Sheets > Between Copies**.
- 2 Print the document.

Stapling printed sheets

For Windows users

- 1 With a document open, click **File > Print**.
- 2 Select a printer, and then click **Properties, Preferences, Options, or Setup**.
- 3 Click **Paper/Finisher**.
If necessary, configure the Paper settings.

- 4 In the Finishing menu, select the staple setting.
- 5 Click **OK** or **Print**.

For Macintosh users

- 1 With a document open, choose **File > Print**.
- 2 Select a printer, and then from the drop-down menu following the Orientation menu, choose **Finishing**.
- 3 Click **Staple**, and then select a setting.
- 4 Click **Print**.

Punching holes in printed sheets

Note: Before you begin, make sure that the hole punch setting is configured. From the home screen, touch **Settings > Device > Maintenance > Configuration Menu > Finisher Configuration > Hole Punch Configuration >** select a configuration.

For Windows users

- 1 With a document open, click **File > Print**.
- 2 Select a printer, and then click **Properties, Preferences, Options, or Setup**.
- 3 Click **Paper/Finisher**.
If necessary, configure the Paper settings.
- 4 In the Finishing menu, select the hole punch setting.
- 5 Click **OK** or **Print**.

For Macintosh users

- 1 With a document open, choose **File > Print**.
- 2 Select a printer, and then from the drop-down menu following the Orientation menu, choose **Finishing**.
- 3 Click **Punch**, and then select a setting.
- 4 Click **Print**.

Folding printed sheets

For Windows users

- 1 With a document open, click **File > Print**.
- 2 Select a printer, and then click **Properties, Preferences, Options, or Setup**.
- 3 Click **Paper/Finisher**.
If necessary, configure the Paper settings.

- 4 In the Finishing menu, select the fold setting.
- 5 Click **OK** or **Print**.

For Macintosh users

- 1 With a document open, choose **File > Print**.
- 2 Select a printer, and then from the drop-down menu following the Orientation menu, choose **Finishing**.
- 3 Click **Fold**, and then select a setting.
- 4 Click **Print**.

Using offset stacking in printed sheets

For Windows users

- 1 With a document open, click **File > Print**.
- 2 Select a printer, and then click **Properties, Preferences, Options, or Setup**.
- 3 Click **Paper/Finisher**.
If necessary, configure the Paper settings.
- 4 In the Finishing menu, select the Offset setting.
- 5 Click **OK** or **Print**.

For Macintosh users

- 1 With a document open, choose **File > Print**.
- 2 Select a printer, and then from the drop-down menu following the Orientation menu, choose **Finishing**.
- 3 Click **Offset**, and then select a setting.
- 4 Click **Print**.

Canceling a print job

- 1 From the home screen, touch .
- 2 Select the job to cancel.

Note: You can also cancel a job by touching **Job Queue**.

Adjusting toner darkness

- 1 From the home screen, touch **Settings > Print > Quality**.
- 2 In the Toner Darkness menu, adjust the settings.

Use printer menus

Menu map

Device	<ul style="list-style-type: none"> • Preferences • Eco-Mode • Remote Operator Panel • Notifications • Power Management • Anonymous Data Collection 	<ul style="list-style-type: none"> • Accessibility • Restore Factory Defaults • Maintenance • Home Screen Customization • About this Printer
Print	<ul style="list-style-type: none"> • Layout • Finishing • Setup • Quality • Job Accounting 	<ul style="list-style-type: none"> • PDF • PostScript • PCL • Image
Paper	<ul style="list-style-type: none"> • Tray Configuration 	<ul style="list-style-type: none"> • Media Configuration
USB Drive	Flash Drive Print	
Network/Ports	<ul style="list-style-type: none"> • Network Overview • Wireless • Wi-Fi Direct • AirPrint • Mobile Services Management • Ethernet • TCP/IP • SNMP 	<ul style="list-style-type: none"> • IPSec • 802.1x • LPD Configuration • HTTP/FTP Settings • ThinPrint • USB • Restrict external network access
Security	<ul style="list-style-type: none"> • Login Methods • Schedule USB Devices • Security Audit Log • Login Restrictions • Confidential Print Setup 	<ul style="list-style-type: none"> • Disk Encryption • Erase Temporary Data Files • Solutions LDAP Settings • Miscellaneous
Cloud Services	Cloud Services Enrollment	
Reports	<ul style="list-style-type: none"> • Menu Settings Page • Device 	<ul style="list-style-type: none"> • Print • Network
Troubleshooting	Print Quality Test Pages	

Device

Preferences

Menu item	Description
Display Language [List of languages]	Set the language of the text that appears on the display.
Country/Region [List of countries or regions]	Identify the country or region where the printer is configured to operate.
Run initial setup Off* On	Run the setup wizard.
Keyboard Keyboard Type [List of languages]	Select a language as a keyboard type. Note: All the Keyboard Type values may not appear or may require special hardware to appear.
Displayed information Display Text 1 (IP Address*) Display Text 2 (Date/Time*) Custom Text 1 Custom Text 2	Specify the information to appear on the home screen.
Date and Time Configure Current Date and Time Manually Set Date and Time Date Format (MM-DD-YYYY*) Time Format (12 hour A.M./P.M.*) Time Zone UTC (GMT) Offset DST Start DST End DST Offset Network Time Protocol Enable NTP (On*) NTP Server Enable Authentication (None*) Key ID Password	Configure the printer date and time and network time protocol. Notes: <ul style="list-style-type: none"> • UTC (GMT) Offset, DST Start, DST End, and DST Offset appear only when Time Zone is set to (UTC+user) Custom. • Key ID and Password appear only when Enable Authentication is set to MD5 key.
Paper Sizes US* Metric	Specify the unit of measurement for paper sizes. Note: The country or region selected in the initial setup wizard determines the initial paper size setting.
Screen Brightness 20–100% (100*)	Adjust the brightness of the display.
Note: An asterisk (*) next to a value indicates the factory default setting.	

Menu item	Description
Flash Drive Access Disabled Enabled*	Enable access to the flash drive.
Device Sounds Mute All Sounds (Off*) Button Feedback (On*) Volume (5*) ADF Loaded Beep (On*) Alarm Control (Single*) Cartridge Alarm (Single*) Speaker Mode (On until Connected*) Ringer Volume (On*)	Configure the sound settings of the printer.
Screen Timeout 5–300 (60*)	Set the idle time in seconds before the display shows the home screen, or before the printer logs out a user account automatically.
Note: An asterisk (*) next to a value indicates the factory default setting.	

Eco-Mode

Menu item	Description
Print Sides (1-Sided*) Pages per Side (Off*) Toner Darkness (4*) Color Saver (Off*)	Configure the print settings of the printer.
Note: An asterisk (*) next to a value indicates the factory default setting.	

Remote Operator Panel

Menu item	Description
External VNC Connection Don't Allow* Allow	Connect an external Virtual Network Computing (VNC) client to the remote control panel.
Authentication Type None* Standard Authentication	Set the authentication type when accessing the VNC client server.
VNC Password	Specify the password to connect to the VNC client server. Note: This menu item appears only if Authentication Type is set to Standard Authentication.
Note: An asterisk (*) next to a value indicates the factory default setting.	

Notifications

Menu item	Description
Alarm Control Off Single* Continuous	Set the number of times that the alarm sounds when the printer requires user intervention.
Supplies Show Supply Estimates Show estimates* Do not show estimates	Show the estimated status of the supplies.
E-mail Alerts Setup E-mail Setup Primary SMTP Gateway Primary SMTP Gateway Port (25*) Secondary SMTP Gateway Secondary SMTP Gateway Port (25*) SMTP Timeout (30 seconds*) Reply Address Always use SMTP default Reply Address (Off*) Use SSL/TLS (Disabled*) Require Trusted Certificate (On*) SMTP Server Authentication (No authentication required*) Device-Initiated E-mail (None*) User-Initiated E-mail (None*) Use Active Directory Device Credentials (Off*) Device Userid Device Password Kerberos 5 REALM NTLM Domain Disable "SMTP server not set up" error(On*)	Configure the e-mail settings of the printer.
Error Prevention Jam Assist Off On*	Set the printer to check for jammed paper automatically.
Error Prevention Auto Continue Off On* (5 seconds)	Let the printer continue processing or printing a job automatically after clearing certain attendance conditions.
Note: An asterisk (*) next to a value indicates the factory default setting.	

Menu item	Description
Error Prevention Auto Reboot Auto Reboot (Reboot always*)	Set the printer to restart when an error occurs.
Error Prevention Auto Reboot Max Auto Reboots (20*)	Set the number of automatic reboots that the printer can perform.
Error Prevention Auto Reboot Auto Reboot Window (720*)	Set the number of seconds before the printer performs an automatic reboot.
Error Prevention Auto Reboot Auto Reboot Counter	Show a read-only information of the reboot counter.
Error Prevention Auto Reboot Reset Auto Reboot Counter	Reset the counter for auto reboot.
Error Prevention Display Short Paper Error On Auto-clear*	Set the printer to show a message when a short paper error occurs. Note: Short paper refers to the size of the paper loaded.
Error Prevention Page Protect Off* On	Set the printer to process the entire page into the memory before printing it.
Jam Content Recovery Jam Recovery Off On Auto*	Set the printer to reprint jammed pages.

Note: An asterisk (*) next to a value indicates the factory default setting.

Power Management

Menu item	Description
Sleep Mode Profile Print from Sleep Mode Stay awake after printing Enter Sleep Mode after printing*	Set the printer to stay awake or enter Sleep mode after printing.

Note: An asterisk (*) next to a value indicates the factory default setting.

Menu item	Description
Sleep Mode Profile Touch to Wake from Deep Sleep Off* On`	Wake the printer from Deep Sleep mode by touching the printer display.
Timeouts Sleep Mode 1–114 minutes (15*)	Set the idle time before the printer begins operating in Sleep mode.
Timeouts Hibernate Timeout Disabled 1 hour 2 hours 3 hours 6 hours 1 day 2 days 3 days* 1 week 2 weeks 1 month	Set the time before the printer turns off.
Timeouts Hibernate Timeout on Connection Hibernate Do Not Hibernate*	Set Hibernate Timeout to turn off the printer while an active Ethernet connection exists.
Schedule Power Modes Schedules Add New Schedule	Schedule the printer when to enter Sleep or Hibernate mode.
Note: An asterisk (*) next to a value indicates the factory default setting.	

Anonymous Data Collection

Menu item	Description
Anonymous Data Collection Device Usage and Performance Information None*	Send printer usage and performance information to Lexmark. Note: Anonymous Data Send Time appears only when you set Anonymous Data Collection to Device Usage and Performance.
Anonymous Data Send Time Start Time Stop Time	
Note: An asterisk (*) next to a value indicates the factory default setting.	

Accessibility

Menu item	Description
Duplicate Key Strike Interval 0–5 (0*)	Set the interval in seconds during which the printer ignores duplicate key presses on an attached keyboard.
Key Repeat Initial Delay 0.25–5 (1*)	Set the initial length of delay in seconds before a repeating key starts repeating. Note: This menu item appears only when a keyboard is attached to the printer.
Key Repeat Rate 0.5–30 (30*)	Set the number of presses per second for a repeating key. Note: This menu item appears only when a keyboard is attached to the printer.
Prolong Screen Timeout Off* On	Let the user remain in the same location and reset the Screen Timeout timer when it expires instead of returning to the home screen.
Headphone Volume 1–10 (5*)	Adjust the headphone volume. Note: This menu item appears only when a headphone is attached to the printer.
Enable Voice Guidance When Headphone Is Attached Off* On	Enable Voice Guidance when a headphone is attached to the printer.
Speak Passwords/PINs Off* On	Set the printer to read out loud passwords or personal identification numbers. Note: This menu item appears only when a headphone or a speaker is attached to the printer.
Speech Rate Very Slow Slow Normal* Fast Faster Very Fast Rapid Very Rapid Fastest	Set the Voice Guidance speech rate. Note: This menu item appears only when a headphone or a speaker is attached to the printer.
Note: An asterisk (*) next to a value indicates the factory default setting.	

Restore Factory Defaults

Menu item	Description
Restore Settings Restore all settings Restore printer settings Restore network settings Restore app settings	Restore the printer factory default settings.

Maintenance

Configuration Menu

Menu item	Description
USB Configuration USB PnP 1* 2	Change the USB driver mode of the printer to improve its compatibility with a personal computer.
USB Configuration USB Speed Full Auto*	Set the USB port to run at full speed and disable its high-speed capabilities.
Tray Configuration Size Sensing Tray [x] Sensing Off On* Oficio/Folio Sensing Folio* Oficio (Mexico) Statement/A5 Sensing Sense Statement* Sense A5 Executive/B5 Sensing Sense Exec* Sense B5	Set the tray to sense automatically the paper size loaded into it.
Tray Configuration Tray Linking Automatic* Off	Set the printer to link the trays that have the same paper type and paper size settings.

Note: An asterisk (*) next to a value indicates the factory default setting.

Menu item	Description
Tray Configuration Show Tray Insert Message Off Only for unknown sizes* Always	Display a message that lets the user change the paper size and paper type settings after inserting the tray.
Tray Configuration Paper Prompts Auto* Multipurpose Feeder Manual Paper	Set the paper source that the user fills when a prompt to load paper appears. Note: For Multipurpose Feeder to appear, in the Paper menu, set Configure MP to Cassette.
Tray Configuration Envelope Prompts Auto* Multipurpose Feeder Manual Envelope	Set the paper source that the user fills when a prompt to load envelope appears. Note: For Multipurpose Feeder to appear, in the Paper menu, set Configure MP to Cassette.
Tray Configuration Action for Prompts Prompt user* Continue Use current	Set the printer to resolve paper- or envelope-related change prompts.
Tray Configuration Envelope Tray Setup Off* On	Allow the envelope tray to be available for print jobs.
Tray Configuration Multiple Universal Sizes Off* On	Allow the support of multiple Universal paper sizes in trays.
Reports Menu Settings Page Event Log Event Log Summary	Print reports about printer menu settings, status, and event logs.
Supply Usage And Counters Clear Supply Usage History	Reset the supply usage history to the factory default level.
Supply Usage And Counters Large Media Adjustments Off* On	Allow adjustments when printing for large or thick media.
Supply Usage And Counters Tiered Coverage Ranges	Adjust the amount of color coverage for each printing range.
Note: An asterisk (*) next to a value indicates the factory default setting.	

Menu item	Description
Printer Emulations PPDS Emulation Off* On	Set the printer to recognize and use the PPDS data stream.
Printer Emulations PS Emulation Off On*	Set the printer to recognize and use the PS data stream.
Printer Emulations Enable Prescribe Off* On	Enable Prescribe emulation.
Printer Emulations Emulator Security Page Timeout (60 minutes*) Reset Emulator After Job (Off*) Disable Printer Message Access (On*)	Configure the security settings of the printer during emulation mode.
Print Configuration Black Only Mode Off* On	Set the printer to print always color content in grayscale .
Print Configuration Color Trapping Off 1 2* 3 4 5	Enhance the printed output to compensate for misregistration in the printer.
Print Configuration Font Sharpening 0–150 (24*)	Set a text point-size value below which the high-frequency screens are used when printing font data. For example, if the value is 24, then all fonts sized 24 points or less use the high-frequency screens.
Device Operations Quiet Mode Off* On	Change the amount of noise that the printer produces. Note: Enabling this setting slows down the overall performance of the printer.
Device Operations Panel Menus Off On*	Enable access to the printer menus from the control panel.
Note: An asterisk (*) next to a value indicates the factory default setting.	

Menu item	Description
Device Operations Safe Mode Off* On	Set the printer to operate in a special mode, in which it attempts to continue offering as much functionality as possible, despite known issues. For example, when set to On, and the duplex motor is nonfunctional, the printer performs one-sided printing of the documents even if the job is two-sided printing.
Device Operations Clear Custom Status	Erase user-defined strings for the Default or Alternate custom messages.
Device Operations Clear all remotely-installed messages	Erase messages that were remotely installed.
Device Operations Automatically Display Error Screens Off On*	Show existing error messages on the display after the printer remains inactive on the home screen for a length of time.
App Configuration LES Applications Off On*	Enable Lexmark Embedded Solutions (LES) applications.
Finisher Configuration Exit Tray 2 Setting Off* On	Enable the use of the second output bin.
Note: An asterisk (*) next to a value indicates the factory default setting.	

Out of Service Erase

Menu item	Description
Out of Service Erase Memory Last Sanitized Hard Disk Last Sanitized ISD last erased	Show a read-only information on when the printer memory or storage drive was last erased. Note: Hard Disk Last Sanitized and ISD last erased appear only when a storage drive is installed.
Out of Service Erase Sanitize all information on nonvolatile memory Erase all printer and network settings Erase all apps and app settings Erase all shortcuts and shortcut settings Sanitize all information on hard disk Erase downloads (Erase all macros, fonts, PFOs, etc.) Erase buffered jobs Erase Held jobs Erase Intelligent Storage Drive	Clear all information on nonvolatile memory and on the storage drive. Note: Sanitize all information on hard disk and Erase Intelligent Storage Drive appear only when a storage drive is installed.

Home Screen Customization

Note: This menu appears only in the Embedded Web Server.

Menu	Description
Status/Supplies Job Queue Settings Change Language Address Book Bookmarks Held Jobs USB Drive App Profiles Lock Device	Specify which icons to show on the home screen.

About this Printer

Menu item	Description
Asset Tag	Specify the identity of the printer. The maximum length is 32 characters.
Printer's Location	Specify the printer location. The maximum length is 63 characters.
Contact	Specify the contact information for the printer. The maximum length is 63 characters.
Firmware Version	Show the firmware version installed on the printer.
Engine	Show the engine number of the printer.
Serial Number	Show the serial number of the printer.
Export Configuration File to USB	Export the configuration file to a flash drive.
Export Compressed Logs to USB	Export the compressed log files to a flash drive.
Send Logs	Send printer log information to Lexmark.

Print

Layout

Menu item	Description
Sides 1-Sided* 2-Sided	Specify whether to print on one side or both sides of the paper.
Note: An asterisk (*) next to a value indicates the factory default setting.	

Menu item	Description
Flip Style Long Edge* Short Edge	Determine which side of the paper is bound when performing two-sided printing.
Blank Pages Print Do Not Print*	Print blank pages that are included in a print job.
Collate Off (1,1,1,2,2,2) On (1,2,1,2,1,2)*	Keep the pages of a print job stacked in sequence, particularly when printing multiple copies of the job.
Separator Sheets None* Between Copies Between Jobs Between Pages	Insert blank separator sheets when printing.
Separator Sheet Source Tray [x] (1*) Multipurpose Feeder	Specify the paper source for the separator sheet.
Pages per Side Off* 2 pages per side 3 pages per side 4 pages per side 6 pages per side 9 pages per side 12 pages per side 16 pages per side	Print multiple page images on one side of a sheet of paper.
Pages per Side Ordering Horizontal* Reverse Horizontal Vertical Reverse Vertical	Specify the positioning of multiple page images when using the Pages per Side menu.
Pages per Side Orientation Auto* Landscape Portrait	Specify the orientation of multiple page images when using the Pages per Side menu.
Pages per Side Border None* Solid	Print a border around each page image when using the Pages per Side menu.
Copies 1–9999 (1*)	Specify the number of copies for each print job.
Note: An asterisk (*) next to a value indicates the factory default setting.	

Menu item	Description
Print Area Normal* Fit to page Whole Page	Set the printable area on a sheet of paper.
Note: An asterisk (*) next to a value indicates the factory default setting.	

Finishing

Menu item	Description
Staple Job Off* 1 staple, top left corner 2 staples, left 1 staple, top right corner 2 staples, top 1 staple, bottom left corner 2 staples, bottom 1 staple, bottom right corner 2 staples, right	Specify the staple position for all print jobs. Note: This menu item appears only when a staple finisher is installed.
Staple Test Start	Determine whether the staple finisher is functioning properly. Note: This menu item appears only when a staple finisher is installed.
Hole Punch Off* On	Punch holes along the edge of the printed output. Note: This menu item appears only when a staple, hole punch finisher is installed.
Hole Punch Mode 2 holes 3 holes 4 holes	Set the hole punch mode for the printed output. Notes: <ul style="list-style-type: none"> 3 holes is the U.S. factory default setting. 4 holes is the international factory default setting. This menu item appears only when a staple, hole punch finisher is installed.
Offset Pages None* Between Copies Between Jobs	Offset the output of each print job or each copy of a print job. Notes: <ul style="list-style-type: none"> Between Copies offsets each copy of a print job if Collate is set to On [1,2,1,2,1,2]. If Collate is set to Off [1,1,2,2,2,2], then each set of printed pages is offset, such as all pages designated as 1 and all pages designated as 2. Between Jobs sets the same offset position for the entire print job regardless of the number of copies printed.
Note: An asterisk (*) next to a value indicates the factory default setting.	

Setup

Menu item	Description
Printer Language PCL Emulation PS Emulation*	Set the printer language. Note: Setting a printer language default does not prevent a software program from sending print jobs that use another printer language.
Job Waiting Off* On	Preserve print jobs requiring supplies so that jobs not requiring the missing supplies can print. Note: This menu item appears only when a printer hard disk is installed.
Job Hold Timeout 0–255 (30*)	Set the time in seconds that the printer waits for user intervention before it holds jobs that require unavailable resources. Note: This menu item appears only when a hard disk is installed.
Printer Usage Max Speed Max Yield*	Determine how the developer units operate during printing. Notes: <ul style="list-style-type: none"> • When set to Max Yield, the developer units slow down or stop while printing groups of black-only pages. • When set to Max Speed, the developer units always run while printing, whether color or black pages are being printed.
Download Target RAM* Disk	Specify where to save all permanent resources that have been downloaded to the printer. Note: This menu item appears only when a printer hard disk is installed.
Resource Save Off* On	Determine what the printer does with downloaded resources when it receives a job that requires more than the available memory. Notes: <ul style="list-style-type: none"> • When set to Off, the printer retains downloaded resources only until memory is needed. Resources associated with the inactive printer language are deleted. • When set to On, the printer preserves all the permanent downloaded resources across all language switches. When necessary, the printer shows memory full messages instead of deleting permanent resources.
Print All Order Alphabetical* Newest First Oldest First	Specify the order when you choose to print all held and confidential jobs.

Note: An asterisk (*) next to a value indicates the factory default setting.

Quality

Menu item	Description
Print Mode Black and White Color*	Set how the printer generates color content.
Print Resolution 2400 Image Q* 1200 dpi	Set the resolution for the printed output.
Toner Darkness 1 to 5 (4*)	Determine the lightness or darkness of text images.
Halftone Normal* Detail	Enhance the printed output to have smoother lines with sharper edges.
Color Saver Off* On	Reduce the amount of toner used to print graphics and images. Note: When set to On, this setting overrides the value of the Toner Darkness setting.
RGB Brightness -6 to 6 (0*)	Adjust the brightness of every RGB and gray object on the page. Note: This setting does not affect files where CMYK color specifications are used.
RGB Contrast -6 to 6 (0*)	Adjust the contrast of every RGB and gray object on a page. Note: This setting does not affect files where CMYK color specifications are used.
RGB Saturation 0 to 5 (0*)	Preserve the black and white values while adjusting the color values of every object on the page. Note: This setting does not affect files where CMYK color specifications are used.
Note: An asterisk (*) next to a value indicates the factory default setting.	

Advanced Imaging

Menu item	Description
Color Balance Cyan (0*) Magenta (0*) Yellow (0*) Black (0*)	Adjust the amount of toner that is used for each color.
Color Balance Reset Defaults	Reset all color settings to their default values.
Note: An asterisk (*) next to a value indicates the factory default setting.	

Menu item	Description
Color Correction Off Auto* Manual	Modify the color settings used to print documents. Notes: <ul style="list-style-type: none"> • Off sets the printer to receive the color correction from the software. • Auto sets the printer to apply different color profiles to each object on the printed page. • Manual allows the customization of the RGB or CMYK color conversions applied to each object on the printed page.
Color Samples Print Color Samples	Print sample pages for each of the RGB and CMYK color conversion tables used in the printer.
Color Adjust	Calibrate the printer to adjust color variations in the printed output.
Spot Color Replacement Set Custom CMYK	Assign specific CMYK values to twenty named spot colors.
Note: An asterisk (*) next to a value indicates the factory default setting.	

Job Accounting

Menu item	Description
Job Accounting Off* On	Set the printer to create a log of the print jobs that it receives. Note: This menu item appears only when a flash memory, a hard disk, or an intelligent storage drive (ISD) is installed.
Accounting Log Frequency Daily Weekly Monthly*	Specify how often the printer creates a log file.
Log Action at End of Frequency None* E-mail Current Log E-mail & Delete Current Log Post Current Log Post & Delete Current Log	Specify how the printer responds when the frequency threshold expires. Note: The value defined in Accounting Log Frequency determines when this action is triggered.
Note: An asterisk (*) next to a value indicates the factory default setting.	

Menu item	Description
Log Action at Near Full None* E-mail Current Log E-mail & Delete Current Log E-mail & Delete Oldest Log Post Current Log Post & Delete Current Log Post & Delete Oldest Log Delete Current Log Delete Oldest Log Delete All But Current Delete All Logs	Specify how the printer responds when the hard disk or ISD is nearly full.
Log Action at Full None* E-mail & Delete Current Log E-mail & Delete Oldest Log Post & Delete Current Log Post & Delete Oldest Log Delete Current Log Delete Oldest Log Delete All But Current Delete All Logs	Specify how the printer responds when hard disk or ISD usage reaches the maximum limit (100MB).
URL to Post Log	Specify where the printer posts job accounting logs.
E-mail Address to Send Logs	Specify the e-mail address to which the printer sends job accounting logs.
Log File Prefix	Specify the prefix for the log files. Note: The current host name defined in the TCP/IP menu is used as the default log file prefix.
Note: An asterisk (*) next to a value indicates the factory default setting.	

PDF

Menu item	Description
Scale To Fit Off* On	Scale the page content to fit the selected paper size.
Annotations Print Do Not Print*	Specify whether to print annotations in the PDF.
Print PDF Error Off On*	Enable the printing of PDF error.
Note: An asterisk (*) next to a value indicates the factory default setting.	

PostScript

Menu item	Description
Print PS Error Off* On	Print a page that describes the PostScript® error. Note: When an error occurs, processing of the job stops, the printer prints an error message, and the rest of the print job is flushed.
Minimum Line Width 1–30 (2*)	Set the minimum stroke width. Note: Jobs printed in 1200 dpi use the value directly.
Lock PS Startup Mode Off On*	Disable the SysStart file.
Image Smoothing Off* On	Enhance the contrast and sharpness of low-resolution images. Note: This setting has no effect on images with a resolution of 300 dpi or higher.
Font Priority Resident* Flash/Disk	Establish the font search order. Notes: <ul style="list-style-type: none"> • Resident sets the printer to search its memory for the requested font before searching the hard disk or intelligent storage drive (ISD). • Flash/Disk sets the printer to search the hard disk or ISD for the requested font before searching the printer memory. • This menu item appears only when a hard disk or an ISD is installed.
Wait Timeout Off On* (40 seconds)	Enable the printer to wait for more data before canceling a print job.
Note: An asterisk (*) next to a value indicates the factory default setting.	

PCL

Menu item	Description
Font Source Resident* Disk Download Flash Font Card All	Select the source which contains the default font selection. Notes: <ul style="list-style-type: none"> • Disk and Flash appear only when a non-defective, non-protected hard disk or intelligent storage drive (ISD) that contains fonts is installed. • Download appears only if downloaded fonts exist in the printer memory. • Font Card appears only when an ISD is installed.
Font Name [List of available fonts] (Courier*)	Select a font from the specified font source.
Note: An asterisk (*) next to a value indicates the factory default setting.	

Menu item	Description
Symbol Set [List of available symbol set] (10U PC-8*)	Specify the symbol set for each font name. Note: A symbol set is a set of alphabetic and numeric characters, punctuation, and special symbols. Symbol sets support the different languages or specific programs such as math symbols for scientific text.
Pitch 0.08–100.00 (10.00*)	Specify the pitch for fixed or monospaced fonts. Note: Pitch refers to the number of fixed-space characters in a horizontal inch of type.
Orientation Portrait* Landscape Reverse Portrait Reverse Landscape	Specify the orientation of text and graphics on the page.
Lines per Page 1–255	Specify the number of lines of text for each page printed through the PCL® data stream. Notes: <ul style="list-style-type: none"> • This menu item activates vertical escapement that causes the selected number of requested lines to print between the default margins of the page. • 60 is the U.S. factory default setting. 64 is the international factory default setting.
PCL5 Minimum Line Width 1–30 (2*)	Set the initial minimum stroke width.
PCLXL Minimum Line Width 1–30 (2*)	
A4 Width 198 mm* 203 mm	Set the width of the logical page on A4-size paper. Note: Logical page is the space on the physical page where data is printed.
Auto CR after LF On Off*	Set the printer to perform a carriage return after a line feed control command. Note: Carriage return is a mechanism that commands the printer to move the position of the cursor to the first position on the same line.
Auto LF after CR On Off*	Set the printer to perform a line feed after a carriage return control command.
Tray Renumber Assign Tray [x] Assign Manual Paper Assign Manual Envelope	Configure the printer to work with a different print driver or custom application that uses a different set of source assignments to request a given paper source.
Tray Renumber View Factory Defaults	Show the factory default value assigned for each paper source.
Note: An asterisk (*) next to a value indicates the factory default setting.	

Menu item	Description
Tray Renumber Restore Defaults	Restore the tray renumber values to their factory defaults.
Print Timeout Off On* (90 seconds)	Set the printer to end a print job after it has been idle for the specified amount of time.
Note: An asterisk (*) next to a value indicates the factory default setting.	

Image

Menu item	Description
Auto Fit On Off*	Select the best available paper size and orientation setting for an image. Note: When set to On, this menu item overrides the scaling and orientation settings for the image.
Invert Off* On	Invert bitonal monochrome images. Note: This menu item does not apply to GIF or JPEG image formats.
Scaling Anchor Top Left Best Fit* Anchor Center Fit Height/Width Fit Height Fit Width	Adjust the image to fit the printable area. Note: When Auto Fit is set to On, Scaling is automatically set to Best Fit.
Orientation Portrait* Landscape Reverse Portrait Reverse Landscape	Specify the orientation of text and graphics on the page.
Note: An asterisk (*) next to a value indicates the factory default setting.	

Paper

Tray Configuration

Menu item	Description
Default Source Tray [x] (1*) Multipurpose Feeder Manual Paper Manual Envelope	Set the paper source for all print jobs.
Paper Size/Type Tray [x] Multi-Purpose Feeder Manual Paper Manual Envelope	Specify the paper size or paper type loaded in each paper source.
Substitute Size Off Statement/A5 Letter/A4 11 x 17/A3 All Listed*	Set the printer to substitute a specified paper size if the requested size is not loaded in any paper source. Notes: <ul style="list-style-type: none"> • Off prompts the user to load the required paper size. • All Listed allows all available substitutions.
Configure MP Cassette* Manual First	Determine the behavior of the multipurpose feeder. Notes: <ul style="list-style-type: none"> • Cassette configures the multipurpose feeder as the automatic paper source. • Manual sets the multipurpose feeder only for manual-feed print jobs. • First configures the multipurpose feeder as the primary paper source.
Note: An asterisk (*) next to a value indicates the factory default setting.	

Media Configuration

Universal Setup

Menu item	Description
Units of Measure Inches Millimeters	Specify the unit of measurement for the universal paper. Note: Inches is the U.S. factory default setting. Millimeters is the international factory default setting.
Portrait Width 3.5–52 inches (8.5*) 89–1321 mm (216*)	Set the portrait width of the universal paper.
Note: An asterisk (*) next to a value indicates the factory default setting.	

Menu item	Description
Portrait Height 3.5–52 inches (14*) 89–1321 mm (356*)	Set the portrait height of the universal paper.
Feed Direction Short Edge* Long Edge	Set the printer to pick paper from the short edge or long edge direction. Note: Long Edge appears only when the longest edge is shorter than the maximum width supported.
Multiple Universal Sizes Tray [x] Multipurpose Feeder	Assign a unique dimension for multiple universal sizes that are loaded in each paper source. Note: This setting appears only when enabled in the Device menu. From the home screen, touch Settings > Device > Maintenance > Configuration Menu > Tray Configuration > Multiple Universal Sizes .
Note: An asterisk (*) next to a value indicates the factory default setting.	

Media Types

Menu item	Description
Plain Card Stock Transparency Recycled Glossy Heavy Glossy Labels Bond Envelope Rough Envelope Letterhead Preprinted Colored Paper Light Heavy Rough/Cotton Custom Type [X]	Specify the texture, weight, and orientation of the paper.

USB Drive

Flash Drive Print

Menu item	Description
Number of Copies 1–9999 (1*)	Set the number of copies.
Paper Source Tray [x] (1*) Multipurpose Feeder Manual Paper Manual Envelope	Set the paper source for the print job.
Collate (1,1,1) (2,2,2) (1,2,3) (1,2,3)*	Keep the pages of a print job stacked in sequence, particularly when printing multiple copies of the job.
Sides 1-Sided* 2-Sided	Specify whether to print on one side or both sides of the paper.
Staple Off* 1 staple, top left corner 2 staples, left 1 staple, top right corner 2 staples, top 1 staple, bottom left corner 2 staples, bottom 1 staple, bottom right corner 2 staples, right 4 staples	Specify the staple position for all print jobs. Note: This menu item appears only when a staple finisher is installed.
Hole Punch Off* 2 holes 3 holes 4 holes	Set the punch mode for all print jobs. Note: This menu item appears only when a staple, hole punch finisher is installed.
Offset Pages None* Between Copies Between Jobs	Offset the output of each print job or each copy of a print job. Notes: <ul style="list-style-type: none"> Between Copies offsets each copy of a print job if Collate is set to On [1,2,1,2,1,2]. If Collate is set to Off [1,1,1,2,2,2], then each set of printed pages is offset, such as all pages designated as 1 and all pages designated as 2. Between Jobs sets the same offset position for the entire print job regardless of the number of copies printed.
Note: An asterisk (*) next to a value indicates the factory default setting.	

Menu item	Description
Flip Style Long Edge* Short Edge	Determine which side of the paper is bound when performing two-sided printing.
Pages per Side Off* 2 pages per side 3 pages per side 4 pages per side 6 pages per side 9 pages per side 12 pages per side 16 pages per side	Print multiple page images on one side of a sheet of paper.
Pages per Side Ordering Horizontal* Reverse Horizontal Reverse Vertical Vertical	Specify the positioning of multiple page images when using Pages per Side menu.
Pages per Side Orientation Auto* Landscape Portrait	Specify the orientation of multiple page images when using Pages per Side menu.
Pages per Side Border None* Solid	Print a border around each page image when using Pages per Side menu.
Separator Sheets Off* Between Copies Between Jobs Between Pages	Insert blank separator sheets when printing.
Separator Sheet Source Tray [x] (1*) Multipurpose Feeder	Specify the paper source for the separator sheet.
Blank Pages Do Not Print* Print	Print blank pages in a print job.
Note: An asterisk (*) next to a value indicates the factory default setting.	

Network/Ports

Network Overview

Menu item	Description
Active Adapter Auto* Standard Network Wireless	Specify the type of the network connection. Note: Wireless is available only in printers connected to a wireless network.
Network Status	Show the connectivity status of the printer network.
Display Network Status on Printer Off On*	Show the network status on the display.
Speed, Duplex	Show the speed of the currently active network card.
IPv4	Show the IPv4 address.
All IPv6 Addresses	Show all IPv6 addresses.
Reset Print Server	Reset all active network connections to the printer. Note: This setting removes all network configuration settings.
Network Job Timeout Off On* (90 seconds)	Set the time before the printer cancels a network print job.
Banner Page Off* On	Print a banner page.
Enable Network Connections Off On*	Enable the printer to connect to a network.
Enable LLDP Off* On	Enable Link Layer Discovery Protocol (LLDP) in the printer.
Note: An asterisk (*) next to a value indicates the factory default setting.	

Wireless

Note: This menu is available only in printers connected to a Wi-Fi network or printers that have a wireless network adapter.

Menu item	Description
Setup Using Mobile App	Configure the Wi-Fi connection using Lexmark Mobile Assistant.

Menu item	Description
Setup On Printer Panel Choose Network Add Wi-Fi Network Network Name Network Mode Infrastructure Wireless Security Mode Disabled* WEP WPA2/WPA - Personal WPA2 - Personal	Configure the Wi-Fi connection using the control panel.
Wi-Fi Protected Setup WPS Auto Detect Off On* Start Push Button Method Start PIN Method	Establish a Wi-Fi network and enable network security. Notes: <ul style="list-style-type: none"> • WPS Auto Detect appears only when the Wireless Security Mode is set to WEP. • Start Push-Button Method connects the printer to a Wi-Fi network when buttons on both the printer and the access point (wireless router) are pressed within a given time. • Start PIN Method connects the printer to a Wi-Fi network when a PIN on the printer is entered into the wireless settings of the access point.
Network Mode BSS Type Infrastructure*	Specify the network mode.
Compatibility 802.11b/g/n (2.4GHz)* 802.11a/b/g/n/ac (2.4GHz/5GHz) 802.11a/n/ac (5GHz)	Specify the standard for the Wi-Fi network. Note: 802.11a/b/g/n/ac (2.4GHz/5GHz) and 802.11a/n/ac (5GHz) only appear when a Wi-Fi option is installed.
Wireless Security Mode Disabled* WEP WPA2/WPA-Personal WPA2-Personal 802.1x - RADIUS	Set the security mode for connecting the printer to Wi-Fi devices.
WEP Authentication Mode Auto* Open Shared	Set the type of Wireless Encryption Protocol (WEP) for the printer. Note: This menu item appears only when the Wireless Security Mode is set to WEP.
Set WEP Key	Specify a WEP password for secure Wi-Fi connection.
WPA2/WPA Personal AES	Enable Wi-Fi security through Wi-Fi Protected Access (WPA). Note: This menu item appears only when the Wireless Security Mode is set to WPA2/WPA-Personal.

Menu item	Description
Set Pre-Shared Key	Set the password for secure Wi-Fi connection.
WPA2-Personal AES	Enable Wi-Fi security through WPA2. Note: This menu item appears only when the Wireless Security Mode is set to WPA2-Personal.
802.1x Encryption Mode WPA+ WPA2*	Enable Wi-Fi security through 802.1x standard. Note: This menu item appears only when the Wireless Security Mode is set to 802.1x - RADIUS.
IPv4 Enable DHCP On* Off Set Static IP Address IP Address Netmask Gateway	Enable and configure IPv4 settings in the printer.
IPv6 Enable IPv6 On* Off Enable DHCPv6 On Off* Stateless Address Autoconfiguration On* Off DNS Server Address Manually Assigned IPv6 Address Manually Assigned IPv6 Router Address Prefix All IPv6 Addresses All IPv6 Router Addresses	Enable and configure IPv6 settings in the printer.
Network Address UAA LAA	View the network addresses.
PCL SmartSwitch Off On*	Set the printer to switch automatically to PCL emulation when a print job requires it, regardless of the default printer language. Note: If PCL SmartSwitch is off, then the printer does not examine incoming data and uses the default printer language specified in the Setup menu.

Menu item	Description
PS SmartSwitch Off On*	Set the printer to switch automatically to PS emulation when a print job requires it, regardless of the default printer language. Note: If PS SmartSwitch is off, then the printer does not examine incoming data and uses the default printer language specified in the Setup menu.
Job Buffering On Off*	Temporarily store print jobs in the hard disk or intelligent storage drive (ISD) before printing. Note: This menu item appears only when a hard disk or an ISD is installed.
Mac Binary PS Auto* On Off	Set the printer to process Macintosh binary PostScript print jobs. Notes: <ul style="list-style-type: none"> • On processes raw binary PostScript print jobs. • Off filters print jobs using the standard protocol.

Wi-Fi Direct

Menu item	Description
Enable Wi-Fi Direct On Off*	Set the printer to connect directly to Wi-Fi devices.
Wi-Fi Direct Name	Specify the name of the Wi-Fi Direct network.
Wi-Fi Direct Password	Set the password to authenticate and validate users on a Wi-Fi connection.
Show Password on Setup Page Off On*	Show the Wi-Fi Direct Password on the Network Setup Page.
Preferred Channel Number 1–11 Auto*	Set the preferred channel of the Wi-Fi network.
Group Owner IP Address	Specify the IP address of the group owner.
Auto-Accept Push Button Requests Off* On	Accept requests to connect to the network automatically. Note: Accepting clients automatically is not secured.
Note: An asterisk (*) next to a value indicates the factory default setting.	

AirPrint

Note: This menu appears only in the Embedded Web Server.

Menu item	Description
All AirPrint Functions	Show the AirPrint status of the printer.
Enable AirPrint On* Off	Enable the AirPrint function. Note: This menu item appears only if Internet Printing Protocol (IPP) or mDNS is disabled.
Bonjour Name	Identify printer designation and location.
Organization Name	
Organizational Unit	
Printer Location	
Printer's Latitude	
Printer's Longitude	
Printer's Altitude	
More Options	
Note: An asterisk (*) next to a value indicates the factory default setting.	

Mobile Services Management

Note: This menu appears only in the Embedded Web Server.

Menu item	Description
Enable IPP Print On* Off	Allow printing from mobile devices using Internet Printing Protocol (IPP).
Enable IPP Fax On* Off	Allow sending faxes using Internet Printing Protocol (IPP).
Enable IPP Over USB On* Off	Allow print or scan jobs using USB connection.
Enable Scan On* Off	Allow scanning using eSCL protocol.
Enable Mopria Discovery On* Off	Allow the printer to be detected by Mopria-enabled devices.
Note: An asterisk (*) next to a value indicates the factory default setting.	

Ethernet

Menu item	Description
Network Speed	Show the speed of the active network adapter.
IPv4 Enable DHCP (On*) Set Static IP Address	Configure the IPv4 settings.
IPv6 Enable IPv6 (On*) Enable DHCPv6 (Off*) Stateless Address Autoconfiguration (On*) DNS Server Address Manually Assigned IPv6 Address Manually Assigned IPv6 Router Address Prefix (64*) All IPv6 Addresses All IPv6 Router Addresses	Configure the IPv6 settings.
Network Address UAA LAA	Specify the network address.
PCL SmartSwitch Off On*	Set the printer to switch automatically to PCL emulation when a print job requires it, regardless of the default printer language. Note: When this setting is disabled, the printer does not examine incoming data and uses the default printer language specified in the Setup menu.
PS SmartSwitch Off On*	Set the printer to switch automatically to PostScript emulation when a print job requires it, regardless of the default printer language. Note: When this setting is disabled, the printer does not examine incoming data and uses the default printer language specified in the Setup menu.
Job Buffering Off* On	Temporarily store jobs on the hard disk before printing. Note: This menu item appears only when a hard disk is installed.
Mac Binary PS Auto* On Off	Set the printer to process Macintosh binary PostScript print jobs. Notes: <ul style="list-style-type: none"> • Auto processes print jobs from computers using either Windows or Macintosh operating systems. • Off filters PostScript print jobs using the standard protocol.
Energy Efficient Ethernet On Off Auto*	Reduce power consumption when the printer does not receive data from the Ethernet network.
Note: An asterisk (*) next to a value indicates the factory default setting.	

TCP/IP

Note: This menu appears only in network printers or printers attached to print servers.

Menu item	Description
Set Hostname	Set the current TCP/IP host name.
Domain Name	Set the domain name.
Allow DHCP/BOOTP to update NTP server On* Off	Allow the DHCP and BOOTP clients to update the NTP settings of the printer.
Zero Configuration Name	Specify a service name for the zero configuration network.
Enable Auto IP Off On*	Assign an IP address automatically.
DNS Server Address	Specify the current Domain Name System (DNS) server address.
Backup DNS Server Address	Specify the backup DNS server addresses.
Backup DNS Server Address 2	
Backup DNS Server Address 3	
Domain Search Order	Specify a list of domain names to locate the printer and its resources that reside in different domains on the network.
Enable DDNS Off* On	Update the Dynamic DNS settings.
DDNS TTL	Specify the current DDNS settings.
Default TTL	
DDNS Refresh Time	
Enable mDNS Off On*	Update the multicast DNS settings.
WINS Server Address	Specify a server address for Windows Internet Name Service (WINS).
Enable BOOTP Off* On	Allow the BOOTP to assign a printer IP address.
Restricted Server List	Specify the IP addresses that are allowed to communicate with the printer over TCP/IP. Notes: <ul style="list-style-type: none"> • Use a comma to separate each IP address. • You can add up to 50 IP addresses.
Note: An asterisk (*) next to a value indicates the factory default setting.	

Menu item	Description
Restricted Server List Options Block All Ports* Block Printing Only Block Printing and HTTP Only	Specify the access option for IP addresses that are not in the list.
MTU 256–1500 Ethernet (1500*)	Specify a maximum transmission unit (MTU) parameter for the TCP connections.
Raw Print Port 1–65535 (9100*)	Specify a raw port number for printers connected on a network.
Outbound Traffic Maximum Speed Off* On	Set the maximum transfer rate of the printer. Note: When enabled, the option for this setting is 100–1000000 Kilobits/second.
TLS Support Enable TLSv1.0 (Off) Enable TLSv1.1 (Off*) Enable TLSv1.2 (On*)	Enable the Transport Layer Security protocol.
SSL Cipher List TLSv1.3 SSL Cipher List	Specify the cipher algorithms to use for the SSL or the TLS connections.
Note: An asterisk (*) next to a value indicates the factory default setting.	

SNMP

Note: This menu appears only in network printers or printers that are attached to print servers.

Menu item	Description
SNMP Versions 1 and 2c Enabled Off On* Allow SNMP Set Off On* Enable PPM MIB Off On* SNMP Community	Configure Simple Network Management Protocol (SNMP) versions 1 and 2c to install print drivers and applications.
Note: An asterisk (*) next to a value indicates the factory default setting.	

Menu item	Description
SNMP Version 3 Enabled Off On* Context Name Set Read/Write Credentials User Name Authentication Password Privacy Password Set Read-only Credentials User Name Authentication Password Privacy Password Authentication Hash MD5 SHA1* Minimum Authentication Level No Authentication, No Privacy Authentication, No Privacy Authentication, Privacy* Privacy Algorithm DES AES-128*	Configure SNMP version 3 to install and update the printer security.
Note: An asterisk (*) next to a value indicates the factory default setting.	

IPSec

Note: This menu appears only in network printers or printers that are attached to print servers.

Menu item	Description
Enable IPSec Off* On	Enable Internet Protocol Security (IPSec).
Base Configuration Default* Compatibility Secure	Set the IPSec base configuration. Note: This menu item appears only when Enable IPSec is set to On.
DH (Diffie-Hellman) Group Proposal modp2048 (14)* modp3072 (15) modp4096 (16) modp6144 (17)	Set the IPSec base configuration. Note: This menu item appears only when Base Configuration is set to Compatibility.
Note: An asterisk (*) next to a value indicates the factory default setting.	

Menu item	Description
Proposed Encryption Method 3DES AES*	Set the encryption method. Note: This menu item appears only when Base Configuration is set to Compatibility.
Proposed Authentication Method SHA1 SHA256* SHA512	Set the authentication method. Note: This menu item appears only when Base Configuration is set to Compatibility.
IKE SA Lifetime (Hours) 1 2 4 8 24*	Specify the IKE SA expiry period. Note: This menu item appears only when Base Configuration is set to Secure.
IPSec SA Lifetime (Hours) 1 2 4 8* 24	Specify the IPSec SA expiry period. Note: This menu item appears only when Base Configuration is set to Secure.
IPSec Device Certificate	Specify an IPSec certificate. Note: This menu item appears only when Enable IPSec is set to On.
Pre-Shared Key Authenticated Connections Host [x]	Configure the authenticated connections of the printer. Note: These menu items appear only when Enable IPSec is set to On.
Certificate Authenticated Connections Host [x] Address[/subnet]	
Note: An asterisk (*) next to a value indicates the factory default setting.	

802.1x

Note: This menu appears only in network printers or printers that are attached to print servers.

Menu item	Description
Active Off* On	Let the printer join networks that require authentication before allowing access.
Note: An asterisk (*) next to a value indicates the factory default setting.	

Menu item	Description
802.1x Authentication Device Login Name Device Login Password Validate Serve Certificate (On*) Enable Event Logging (Off*) 802.1x Device Certificate	Configure the settings for authenticating the 802.1x connection.
Allowable Authentication Mechanisms EAP - MD5 (On*) EAP - MSCHAPv2 (On*) LEAP (On*) PEAP (On*) EAP - TLS (On*) EAP - TTLS (On*) TTLS Authentication Method (MSCHAPv2*)	Configure the allowed authentication mechanisms for the 802.1x connection.
Note: An asterisk (*) next to a value indicates the factory default setting.	

LPD Configuration

Note: This menu appears only in network printers or printers that are attached to print servers.

Menu item	Description
LPD Timeout 0–65535 seconds (90*)	Set the time-out value to stop the Line Printer Daemon (LPD) server from waiting indefinitely for hung or invalid print jobs.
LPD Banner Page Off* On	Print a banner page for all LPD print jobs. Note: A banner page is the first page of a print job used as a separator of print jobs and to identify the originator of the print job request.
LPD Trailer Page Off* On	Print a trailer page for all LPD print jobs. Note: A trailer page is the last page of a print job.
LPD Carriage Return Conversion Off* On	Enable carriage return conversion. Note: Carriage return is a mechanism that commands the printer to move the position of the cursor to the first position on the same line.
Note: An asterisk (*) next to a value indicates the factory default setting.	

HTTP/FTP Settings

Menu item	Description
Proxy HTTP Proxy IP Address HTTP Default IP Port FTP Proxy IP Address FTP Default IP Port Authentication User Name Password Local Domains	Configure the HTTP and FTP server settings.
Other Settings Enable HTTP Server (On*)	Access the Embedded Web Server to monitor and manage the printer.
Other Settings Enable HTTPS (On*)	Enable Hypertext Transfer Protocol Secure (HTTPS) to encrypt data transferring to and from the print server.
Other Settings Force HTTPS Connections (Off*)	Force the printer to use HTTPS connections.
Other Settings Enable FTP/TFTP (On*)	Send files using FTP/TFTP.
Other Settings HTTPS Device Certificate (default*)	View the HTTP device certificate used on the printer.
Other Settings Timeout for HTTP/FTP Requests (30*)	Specify the amount of time before the server connection stops.
Other Settings Retries for HTTP/FTP Requests (3*)	Set the number of retries to connect to the HTTP/FTP server.
Note: An asterisk (*) next to a value indicates the factory default setting.	

ThinPrint

Menu item	Description
Enable ThinPrint Off* On	Print using ThinPrint.
Port Number 4000–4999 (4000*)	Set the port number for the ThinPrint server.
Bandwidth (bits/sec) 100–1000000 (0*)	Set the speed to transmit data in a ThinPrint environment.
Packet Size (kbytes) 0–64000 (0*)	Set the packet size for data transmission.
Note: An asterisk (*) next to a value indicates the factory default setting.	

USB

Menu item	Description
PCL SmartSwitch Off On*	Set the printer to switch to PCL emulation when a print job received through a USB port requires it, regardless of the default printer language. Note: When this setting is disabled, the printer does not examine incoming data and uses the default printer language specified in the Setup menu.
PS SmartSwitch Off On*	Set the printer to switch to PostScript emulation when a print job received through a USB port requires it, regardless of the default printer language. Note: When this setting is disabled, the printer does not examine incoming data and uses the default printer language specified in the Setup menu.
Job Buffering Off* On	Temporarily store print jobs in the hard disk or intelligent storage drive (ISD) before printing. Note: This menu item appears only when a hard disk or an ISD is installed.
Mac Binary PS Auto* On Off	Set the printer to process Macintosh binary PostScript print jobs. Notes: <ul style="list-style-type: none"> • Auto processes print jobs from computers using either Windows or Macintosh operating systems. • Off filters PostScript print jobs using the standard protocol.
Enable USB Port Off On*	Enable the front USB drive port.
Note: An asterisk (*) next to a value indicates the factory default setting.	

Restrict external network access

Menu item	Description
Restrict external network access Off* On	Restrict access to network sites.
External network address	Specify the network addresses with restricted access.
E-mail address for notification	Specify an e-mail address to send a notification of logged events.
Ping frequency 1–300 (10*)	Specify the network query interval in seconds.
Subject	Specify the subject and message of the notification e-mail.
Message	
Note: An asterisk (*) next to a value indicates the factory default setting.	

Security

Login Methods

Manage Permissions

Menu item	Description
Function Access Modify Address Book Manage Shortcuts Create Profiles Manage Bookmarks Flash Drive Print Flash Drive Color Printing Held Jobs Access Use Profiles Cancel Jobs at the Device Change Language Internet Printing Protocol (IPP) B/W Print Color Print	Control access to the printer functions.
Administrative Menus Security Menu Network/Ports Menu Paper Menu Reports Menu Function Configuration Menus Supplies Menu Option Card Menu SE Menu Device Menu	Control access to the printer menus.
Device Management Remote Management Firmware Updates Apps Configuration Operator Panel Lock Embedded Web Server Access Import / Export All Settings Out of Service Erase Cloud Services Enrollment	Control access to the printer management options.

Menu item	Description
Apps New Apps Slideshow Change Wallpaper Screen Saver	Control access to the printer applications.

Local Accounts

Menu item	Description
Manage Groups/Permissions	Show a list of all saved groups in the printer.
Add User User Name/Password User Name Password PIN	Create local accounts and specify their access to the printer functions, administrative menus, printer management options, and applications.

Schedule USB Devices

Menu item	Description
Schedules Add New Schedule	Schedule access to the front USB port.

Security Audit Log

Menu item	Description
Enable Audit Off* On	Record the events in the secure audit log and remote syslog.
Enable Remote Syslog Off* On	Send audit logs to a remote server.
Remote Syslog Server	Specify the remote syslog server.
Remote Syslog Port 1–65535 (514*)	Specify the remote syslog port.
Remote Syslog Method Normal UDP* Stunnel	Specify a syslog method to transmit logged events to a remote server.
Note: An asterisk (*) next to a value indicates the factory default setting.	

Menu item	Description
Remote Syslog Facility 0 - Kernel Messages 1 - User-Level Messages 2 - Mail System 3 - System Daemons 4 - Security/Authorization Messages* 5 - Messages Generated Internally by Syslogs 6 - Line Printer Subsystem 7 - Network News Subsystem 8 - UUCP Subsystem 9 - Clock Daemon 10 - Security/Authorization Messages 11 - FTP Daemon 12 - NTP Subsystem 13 - Log Audit 14 - Log Alert 15 - Clock Daemon 16 - Local Use 0 (local0) 17 - Local Use 1 (local1) 18 - Local Use 2 (local2) 19 - Local Use 3 (local3) 20 - Local Use 4 (local4) 21 - Local Use 5 (local5) 22 - Local Use 6 (local6) 23 - Local Use 7 (local7)	Specify a facility code that the printer uses when sending log events to a remote server.
Severity of Events to Log 0 - Emergency 1 - Alert 2 - Critical 3 - Error 4 - Warning* 5 - Notice 6 - Informational 7 - Debug	Specify the priority level cutoff for logging messages and events.
Remote Syslog Non-Logged Events Off* On	Send all events, regardless of severity level, to the remote server.
Admin's E-mail Address	Send e-mail notification of logged events to the administrator.
Note: An asterisk (*) next to a value indicates the factory default setting.	

Menu item	Description
E-mail Log Cleared Alert Off* On	Send e-mail notification to the administrator when a log entry is deleted.
E-mail Log Wrapped Alert Off* On	Send e-mail notification to the administrator when the log becomes full and begins to overwrite the oldest entries.
Log Full Behavior Wrap Over Oldest Entries* E-mail Log Then Delete All Entries	Resolve log storage issues when the log fills its allotted memory.
E-mail % Full Alert Off* On	Send e-mail notification to the administrator when the log fills its allotted memory.
% Full Alert Level 1–99 (90*)	
E-mail Log Exported Alert Off* On	Send e-mail notification to the administrator when a log is exported.
E-mail Log Settings Changed Alert Off* On	Send e-mail notification to the administrator when Enable Audit is set.
Log Line Endings LF (\n)* CR (\r) CRLF (\r\n)	Specify how the log file terminates the end of each line.
Digitally Sign Exports Off* On	Add a digital signature to each exported log file.
Clear Log	Delete all audit logs.
Export Log Syslog (RFC 5424) Syslog (RFC 3164) CSV	Export a security log to a flash drive.
Note: An asterisk (*) next to a value indicates the factory default setting.	

Login Restrictions

Menu item	Description
Login failures 1–10 (3*)	Specify the number of failed login attempts before the user gets locked out.
Failure time frame 1–60 minutes (5*)	Specify the time frame between failed login attempts before the user gets locked out.
Lockout time 1–60 minutes (5*)	Specify the lockout duration.
Web Login Timeout 1–120 minutes (10*)	Specify the delay for a remote login before the user is logged off automatically.
Note: An asterisk (*) next to a value indicates the factory default setting.	

Confidential Print Setup

Menu item	Description
Max Invalid PIN 2–10	Set the limit for entering an invalid PIN. Note: When the limit is reached, the print jobs for that user name are deleted.
Confidential Job Expiration Off* 1 Hour 4 Hours 24 Hours 1 Week	Set an individual expiration time for each held job before it is automatically deleted from the hard disk or intelligent storage drive. Note: A held job is either Confidential, Repeat, Reserve, or Verify.
Repeat Job Expiration Off* 1 Hour 4 Hours 24 Hours 1 Week	Set the expiration time for a print job that you want to repeat.
Verify Job Expiration Off* 1 Hour 4 Hours 24 Hours 1 Week	Set the expiration time for printing a copy of a job for you to check its quality before printing the remaining copies.
Reserve Job Expiration Off* 1 Hour 4 Hours 24 Hours 1 Week	Set the expiration time for jobs that you want to store in the printer for printing later.
Note: An asterisk (*) next to a value indicates the factory default setting.	

Menu item	Description
Require All Jobs to be Held Off* On	Set the printer to hold all print jobs.
Keep duplicate documents Off* On	Set the printer to keep all documents with the same file name.
Note: An asterisk (*) next to a value indicates the factory default setting.	

Disk Encryption

Note: This menu appears only when a hard disk or an intelligent storage drive is installed.

Menu item	Description
Hard Disk	Show the encryption status of the hard disk.
Intelligent Storage Drive	Show the encryption status of the intelligent storage drive (ISD). Note: The ISD is automatically disabled when a hard disk is installed.

Erase Temporary Data Files

Menu item	Description
Stored in onboard memory Off* On	Delete all files stored on the printer memory.
Stored on hard disk 1 Pass Erase* 3 Pass Erase 7 Pass Erase	Delete all files stored on the printer hard disk. Note: This menu item appears only when a printer hard disk is installed.
Note: An asterisk (*) next to a value indicates the factory default setting.	

Solutions LDAP Settings

Menu item	Description
Follow LDAP Referrals Off* On	Search the different servers in the domain for the logged-in user account.
LDAP Certificate Verification Yes No*	Enable verification of LDAP certificates.

Miscellaneous

Menu item	Description
Protected Features Show* Hide	Show all the features that Function Access Control (FAC) protects regardless of the security permission that the user has. Note: Hide displays only FAC-protected features that the user has access.
Print Permission Off* On	Let the user log in before printing.
Default Print Permission Login User Name/Password* User Name	Set the default login for Print Permission.
Security Reset Jumper Enable "Guest" access* No Effect	Specify user access to the printer. Notes: <ul style="list-style-type: none"> • Enable "Guest" access provides anyone access to all aspects of the printer. • No Effect may make access to the printer impossible when the required security information is unavailable.
Use Intelligent Storage Drive for User Data Off On*	Enable intelligent storage drive to store user data. Note: This menu item is disabled when a hard disk is installed.
Minimum Password Length 0–32 (0*)	Specify the password length.
Enable Password/PIN Reveal Off* On	Show the password or personal identification number.
Note: An asterisk (*) next to a value indicates the factory default setting.	

Cloud Services

Cloud Services Enrollment

Menu item	Description
View More Information	View additional information on the usage of Lexmark Cloud Services.
Enable communication with Lexmark Cloud Services Off* On	Enable the printer to communicate with Lexmark Cloud Services.
Note: An asterisk (*) next to a value indicates the factory default setting.	

Menu item	Description
View Current Status	View the connection status between the printer and Lexmark Cloud Services.
Note: An asterisk (*) next to a value indicates the factory default setting.	

Reports

Menu Settings Page

Menu item	Description
Menu Settings Page	Print a report that contains the printer menus.

Device

Menu item	Description
Device Information	Print a report that contains information about the printer.
Device Statistics	Print a report about printer usage and supply status.
Profiles List	Print a list of profiles that are stored in the printer.
Asset Report	Print a diagnostic tool for print problems. Note: To avoid clipping the content, print the report on letter- or A4-size paper.

Print

Menu item	Description
Print Fonts PCL Fonts PS Fonts	Print samples and information about the fonts that are available in each printer language.
Print Demo Demo Page	Print a page that shows the printer capabilities and supported solutions.
Print Directory	Print the resources that are stored in the flash drive, hard disk, or intelligent storage drive (ISD). Note: This menu item appears only when a flash drive, a hard disk, or an ISD is installed.

Network

Menu item	Description
Network Setup Page	Print a page that shows the configured network and wireless settings on the printer. Note: This menu item appears only in network printers or printers connected to print servers.
Wi-Fi Direct Connected Clients	Print a page that shows the list of devices that are connected to the printer using Wi-Fi Direct. Note: This menu item appears only when Enable Wi-Fi Direct is set to On.

Troubleshooting

Menu item	Description
Print Quality Test Pages	Print sample pages to identify and correct print quality defects.

Printing the Menu Settings Page

From the home screen, touch **Settings > Reports > Menu Settings Page**.

Maintain the printer

Warning—Potential Damage: Failure to maintain optimum printer performance, or to replace parts and supplies, may cause damage to your printer.

Checking the status of parts and supplies

- 1 From the home screen, touch **Status/Supplies**.
- 2 Select the parts or supplies that you want to check.

Note: You can also access this setting by touching the top section of the home screen.

Configuring supply notifications

- 1 Open a web browser, and then type the printer IP address in the address field.

Notes:

- View the printer IP address on the printer home screen. The IP address appears as four sets of numbers separated by periods, such as 123.123.123.123.
- If you are using a proxy server, then temporarily disable it to load the web page correctly.

- 2 Click **Settings > Device > Notifications**.
- 3 From the Supplies menu, click **Custom Supply Notifications**.
- 4 Select a notification for each supply item.
- 5 Apply the changes.

Setting up e-mail alerts

Configure the printer to send e-mail alerts when supplies are low, when paper must be changed or added, or when there is a paper jam.

- 1 Open a web browser, and then type the printer IP address in the address field.

Notes:

- View the printer IP address on the printer home screen. The IP address appears as four sets of numbers separated by periods, such as 123.123.123.123.
- If you are using a proxy server, then temporarily disable it to load the web page correctly.

- 2 Click **Settings > Device > Notifications > E-mail Alert Setup**, and then configure the settings.

Note: For more information on SMTP settings, contact your e-mail provider.

- 3 Apply the changes.
- 4 Click **Setup E-mail Lists and Alerts**, and then configure the settings.
- 5 Apply the changes.

Viewing reports

- 1 From the home screen, touch **Settings > Reports**.
- 2 Select the report that you want to view.

Ordering parts and supplies

To order supplies in the U.S., contact Lexmark at 1-800-539-6275 for information about Lexmark authorized supplies dealers in your area. In other countries or regions, go to www.lexmark.com or contact the place where you purchased the printer.

Note: All life estimates for printer supplies assume printing on letter- or A4-size plain paper.

Warning—Potential Damage: Failure to maintain optimum printer performance, or to replace parts and supplies, may cause damage to your printer.

Using genuine Lexmark parts and supplies

Your Lexmark printer is designed to function best with genuine Lexmark parts and supplies. Use of third-party supplies or parts may affect the performance, reliability, or life of the printer and its imaging components. It can also affect warranty coverage. Damage caused by the use of third-party parts and supplies is not covered by the warranty. All life indicators are designed to function with Lexmark parts and supplies, and may deliver unpredictable results if third-party parts and supplies are used. Imaging component usage beyond the intended life may damage your Lexmark printer or its associated components.

Warning—Potential Damage: Supplies and parts without Return Program agreement terms may be reset and remanufactured. However, the manufacturer's warranty does not cover any damage caused by non-genuine supplies or parts. Resetting counters on the supply or part without proper remanufacturing can cause damage to your printer. After resetting the supply or part counter, your printer may display an error indicating the presence of the reset item.

Ordering a toner cartridge

Notes:

- The estimated cartridge yield is based on the ISO/IEC 19798 standard.
- Extremely low print coverage for extended periods of time may negatively affect actual yield.

Lexmark CS943 toner cartridges

Item	Worldwide
Cyan	73D0HC0
Magenta	73D0HM0
Yellow	73D0HY0
Black	73D0HK0

Ordering a photoconductor unit

Item	Worldwide
Photoconductor unit	73D0P00
Photoconductor unit 3-Pack	73D0Q00

Ordering the waste toner bottle

Item	Part number
Waste toner bottle	73D0W00

Replacing parts and supplies

Replacing a toner cartridge

- 1 Open the front door.

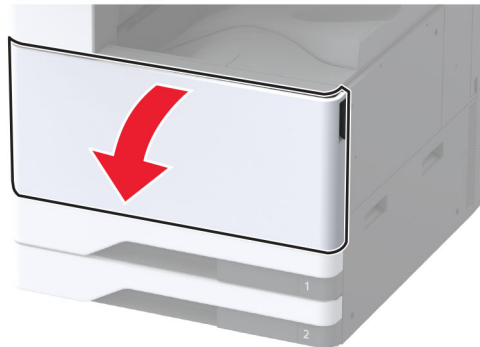

- 2 Remove the used toner cartridge.

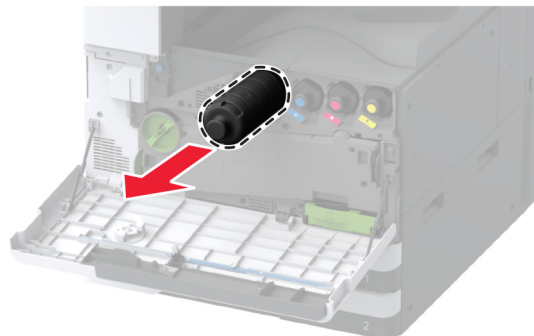

- 3 Unpack the new toner cartridge.

4 Shake the toner cartridge to redistribute the toner.



5 Insert the new toner cartridge.



6 Remove the waste toner transfer unit.

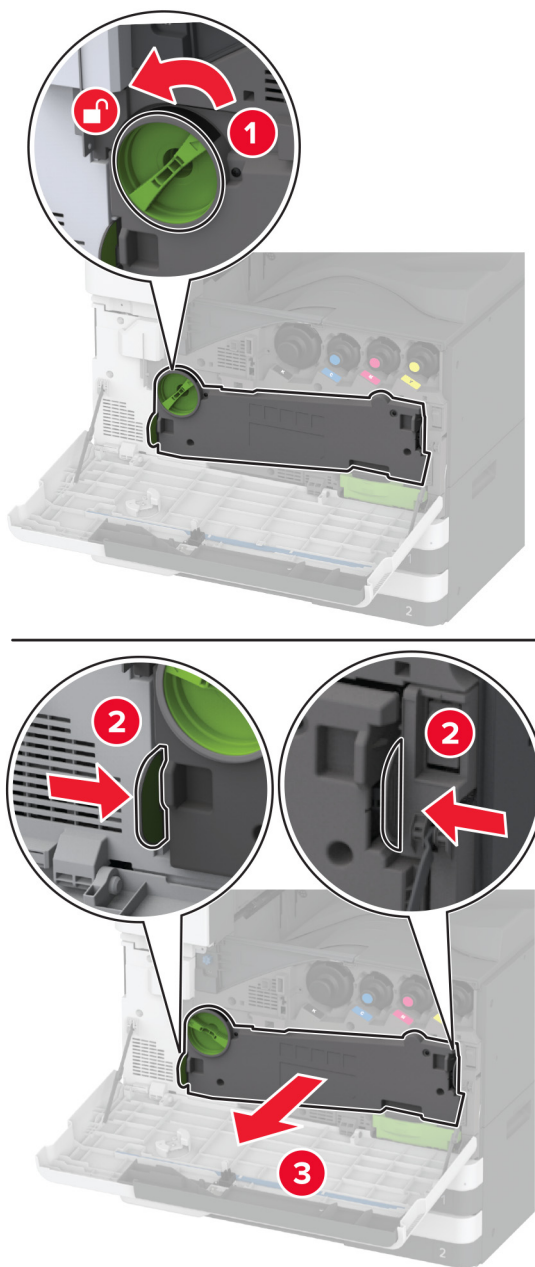

Note: To avoid spilling the toner, place the unit in an upright position.

7 Remove the printhead wiper, and then clean the printhead lenses.

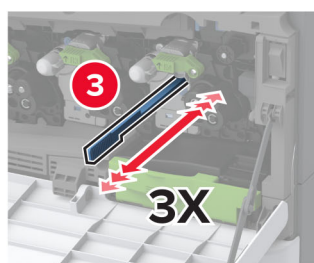
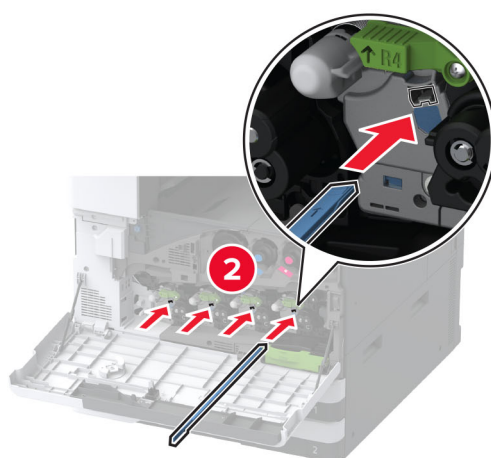
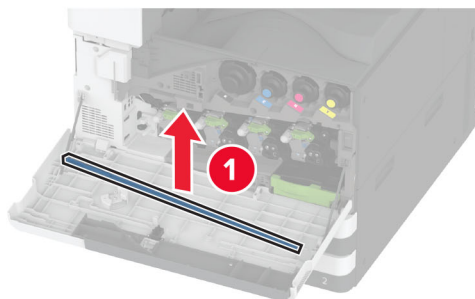

8 Put the printhead wiper back into place.

9 Insert the waste toner transfer unit until it *clicks* into place, and then lock it.

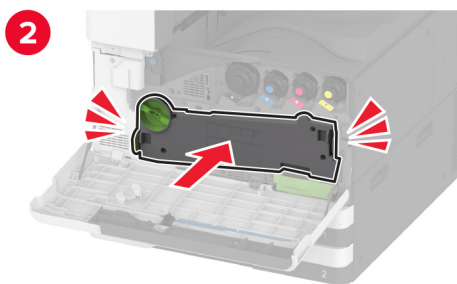
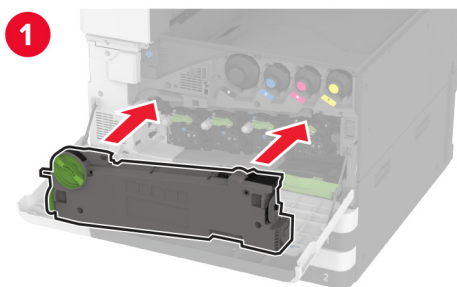

10 Close the door.

Replacing a photoconductor unit

- 1 Open the front door.

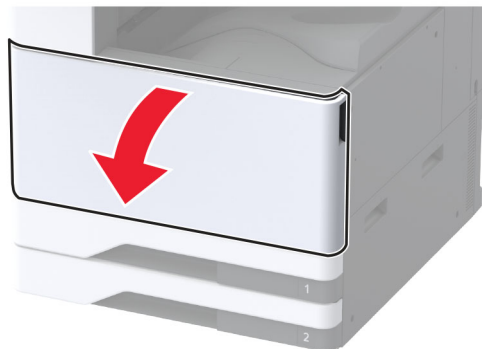

2 Remove the waste toner transfer unit.

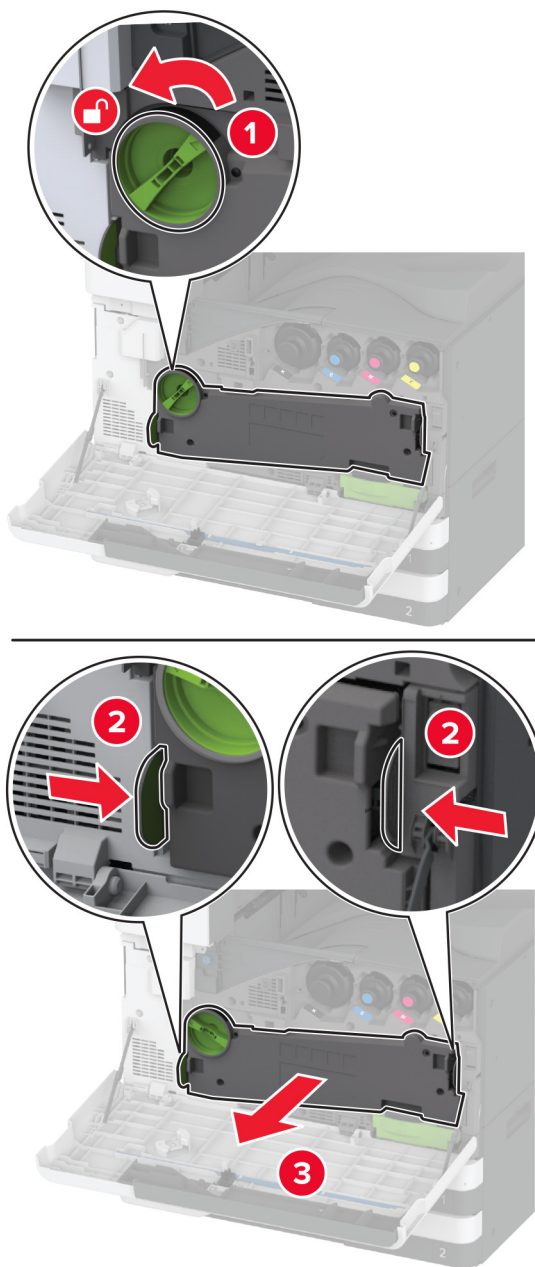

Note: To avoid spilling the toner, place the unit in an upright position.

3 Unlock the used photoconductor unit.

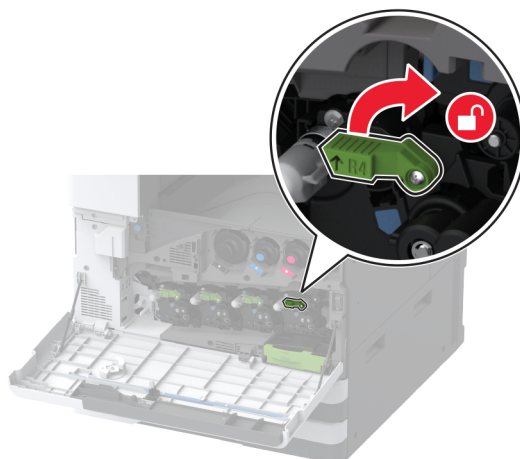

4 Remove the used photoconductor unit.

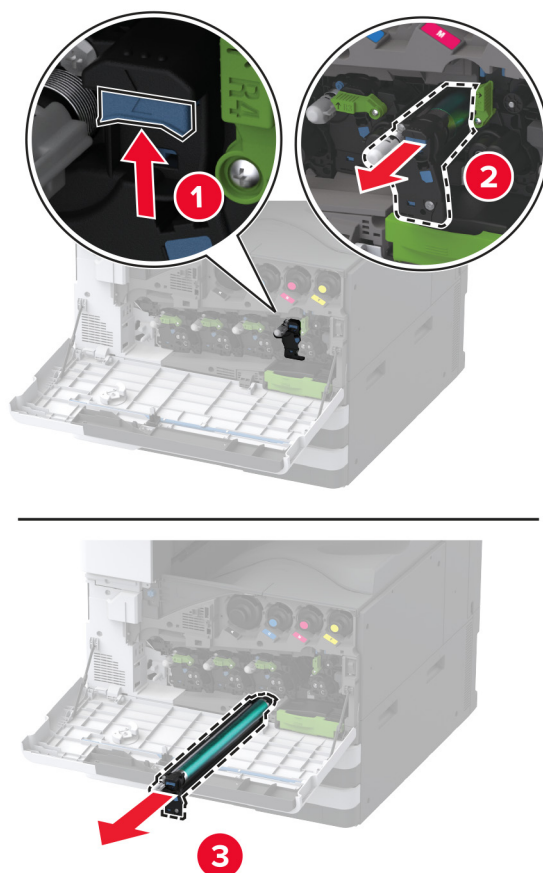

- 5 Unpack the new photoconductor unit.

Warning—Potential Damage: Do not expose the photoconductor unit to direct light for more than one minute. Extended exposure to light may cause print quality problems.

Warning—Potential Damage: Do not touch the photoconductor drum. Doing so may affect the quality of future print jobs.

- 6 Insert the new photoconductor unit until it *clicks* into place.

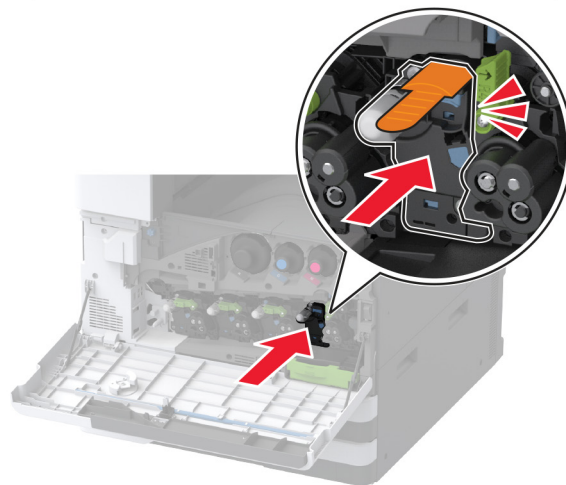
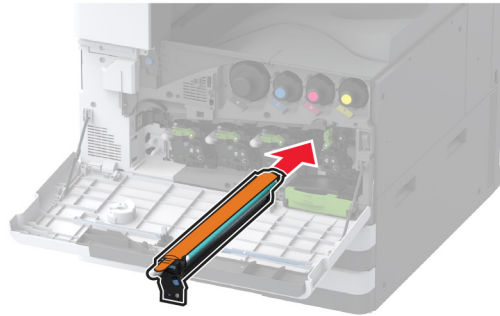

7 Remove the packing material, and then lock the new photoconductor unit.



8 Remove the printhead wiper, and then clean the printhead lenses.

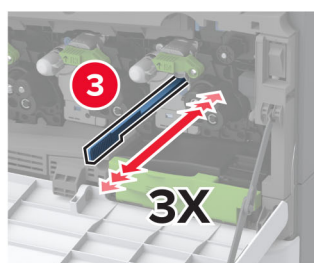
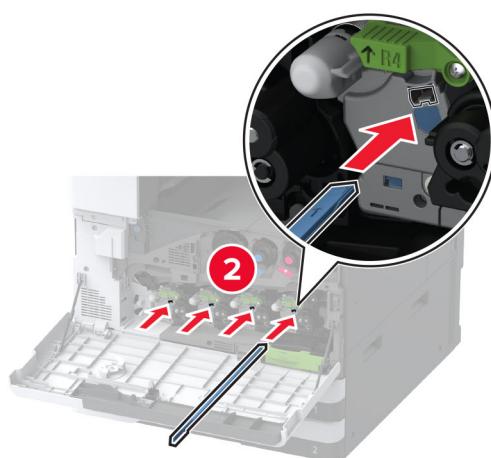
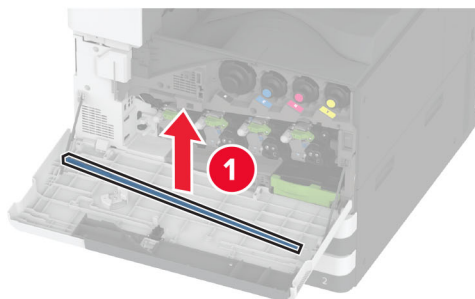

9 Put the printhead wiper back into place.

10 Insert the waste toner transfer unit until it *clicks* into place, and then lock it.

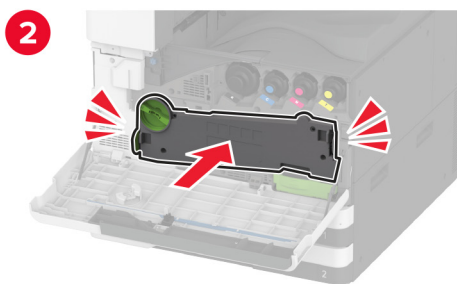
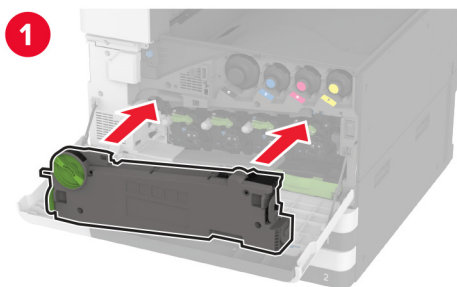

11 Close the door.

Replacing the 520-sheet tray insert

- 1 Remove the used tray insert.

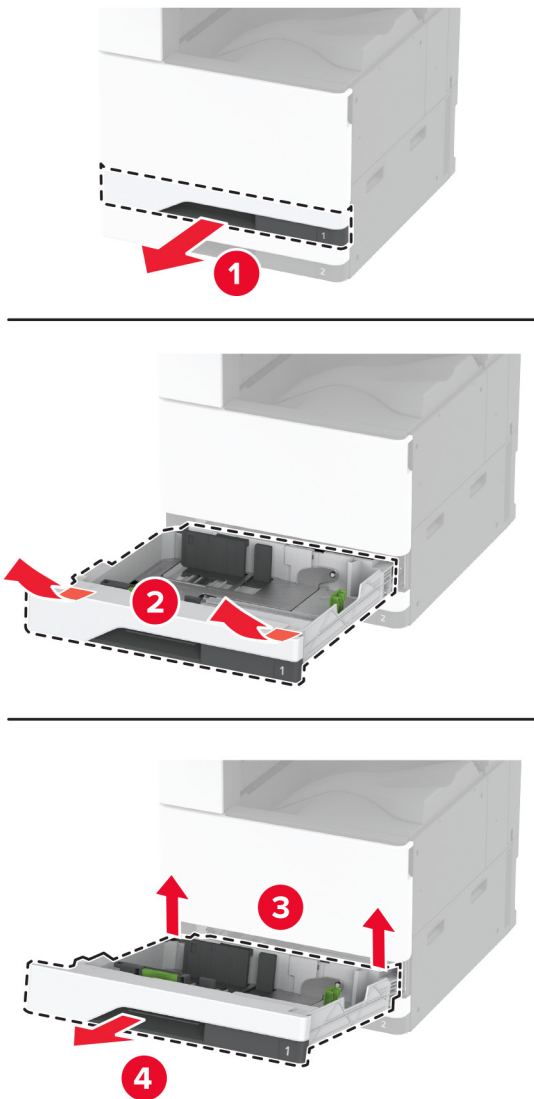

- 2 Unpack the new tray insert, and then remove all the packing material.

3 Insert the new tray insert.

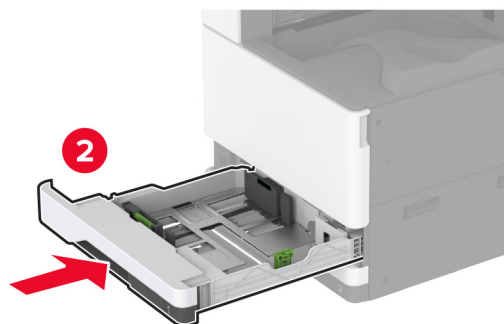
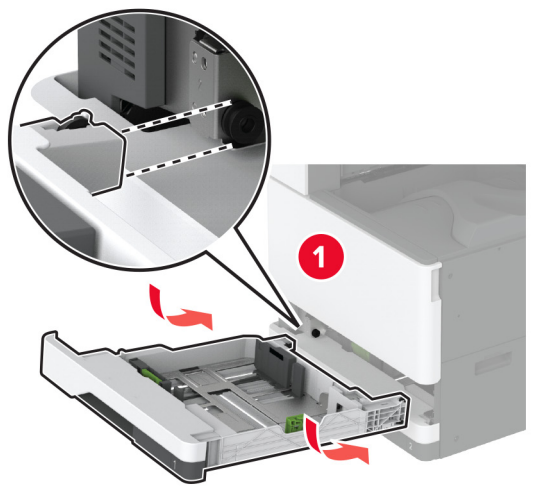

Replacing the fuser

- 1 Turn off the printer.

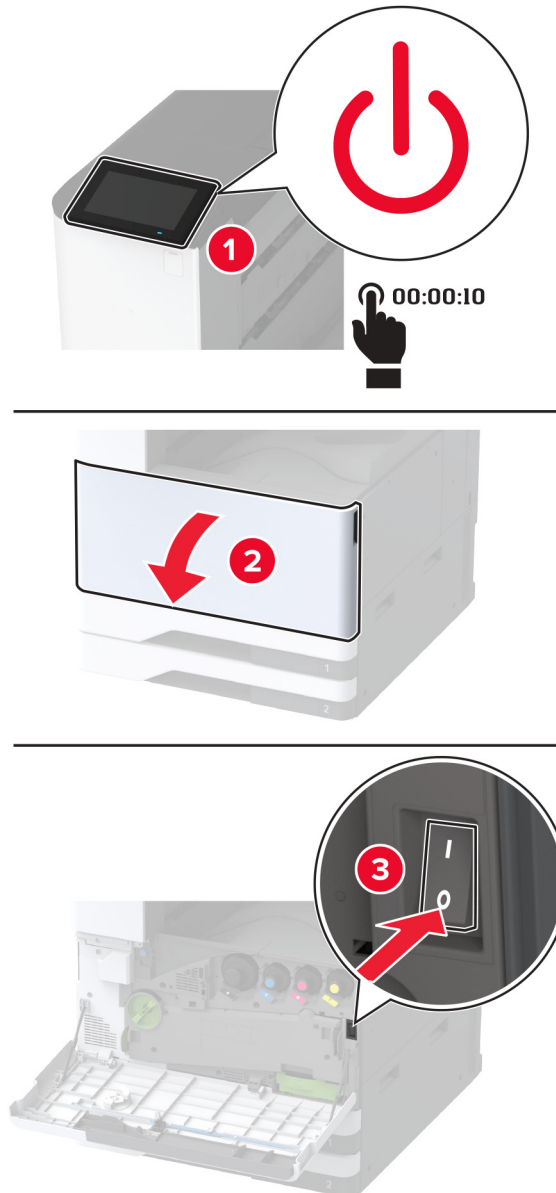

- 2 Open door A.

 **CAUTION—HOT SURFACE:** The inside of the printer might be hot. To reduce the risk of injury from a hot component, allow the surface to cool before touching it.

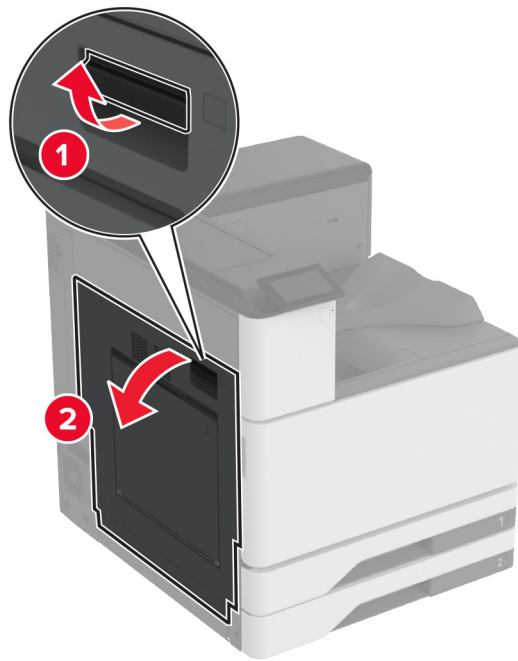

3 Unlock the fuser.

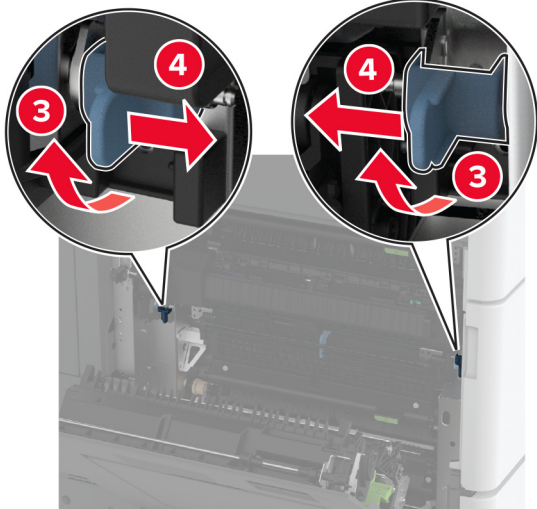
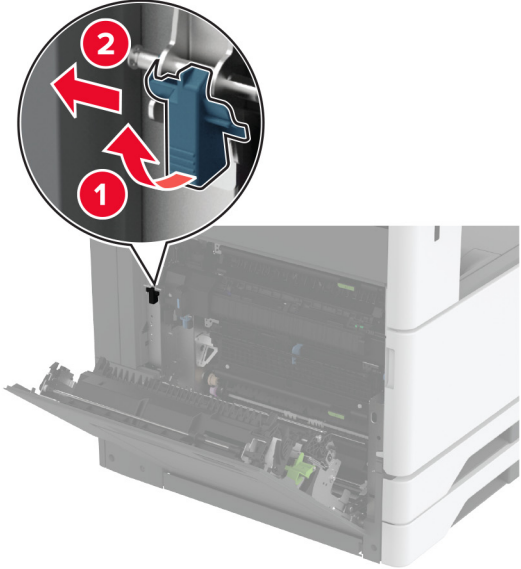

4 Remove the used fuser.

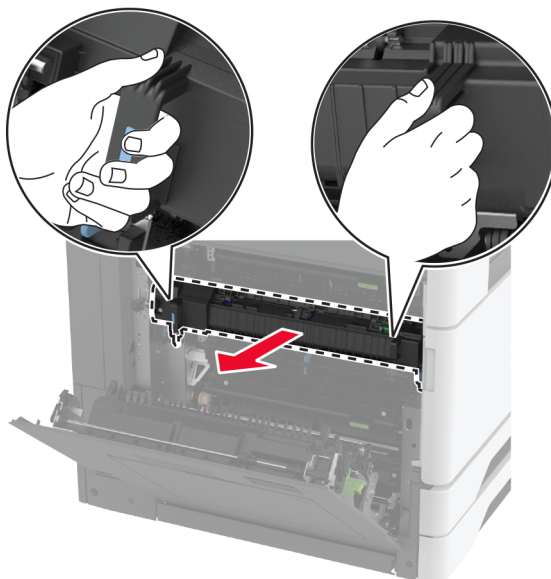

5 Unpack the new fuser.

6 Insert the new fuser until it *clicks* into place, and then lock it.

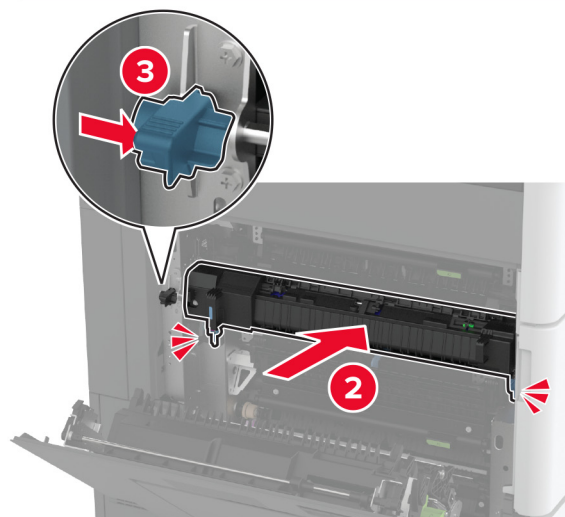
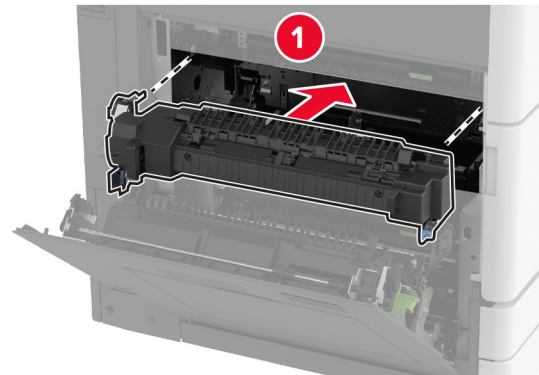

7 Close door A.

8 Turn on the printer.

Replacing the printhead wiper

1 Open the front door.

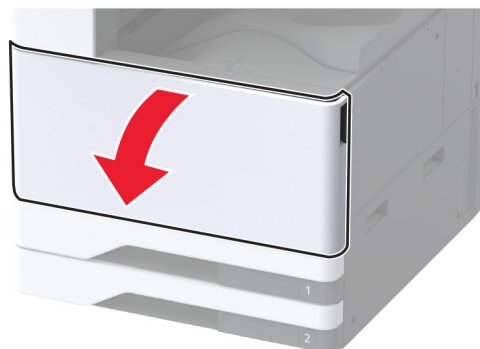

2 Remove the used printhead wiper.

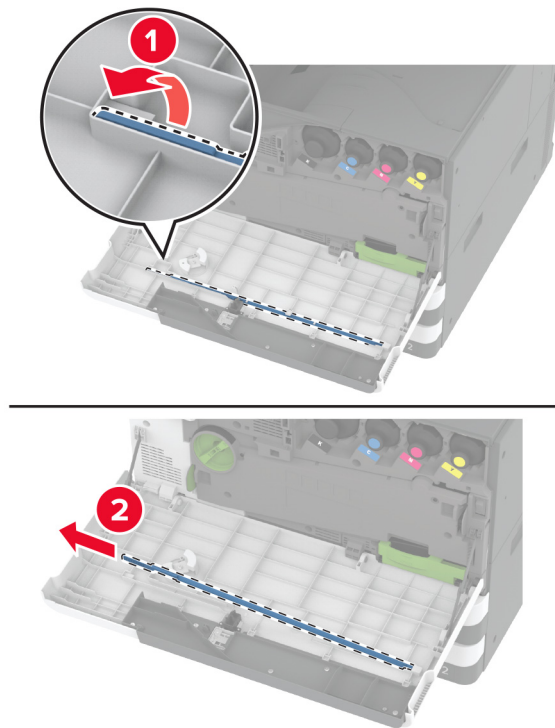

3 Unpack the new printhead wiper.

4 Insert the new printhead wiper.

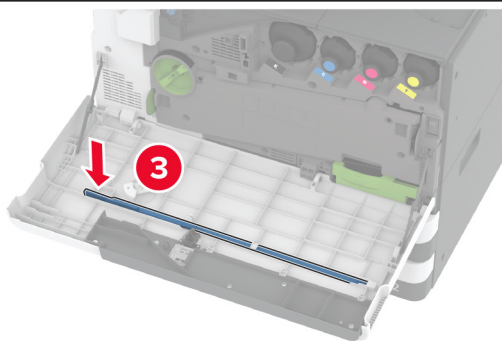
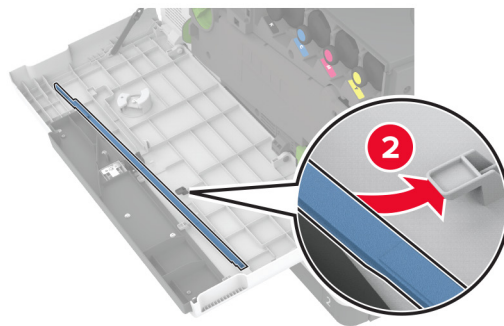
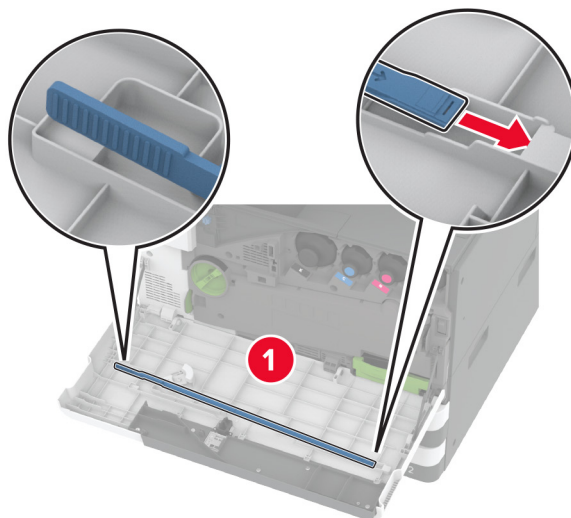

5 Close the front door.

Replacing the transfer module cleaner

- 1 Open the front door.

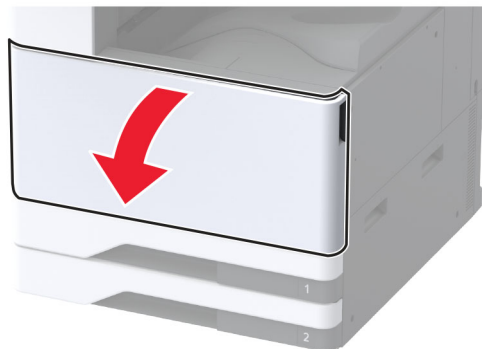

2 Remove the waste toner transfer unit.

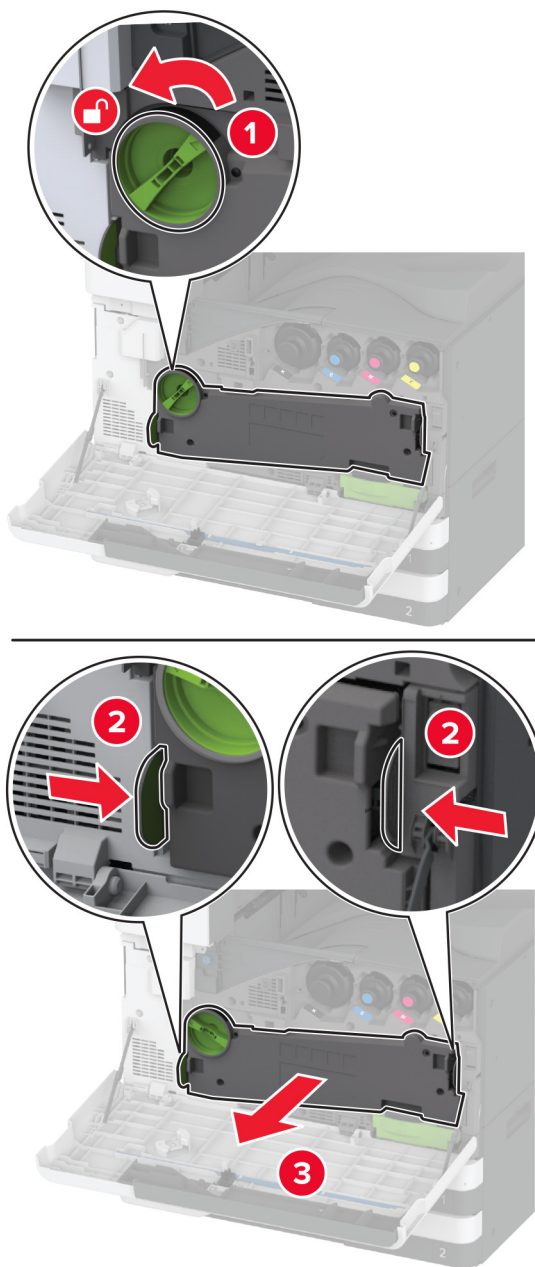

Note: To avoid spilling the toner, place the unit in an upright position.

3 Remove the used transfer module cleaner.

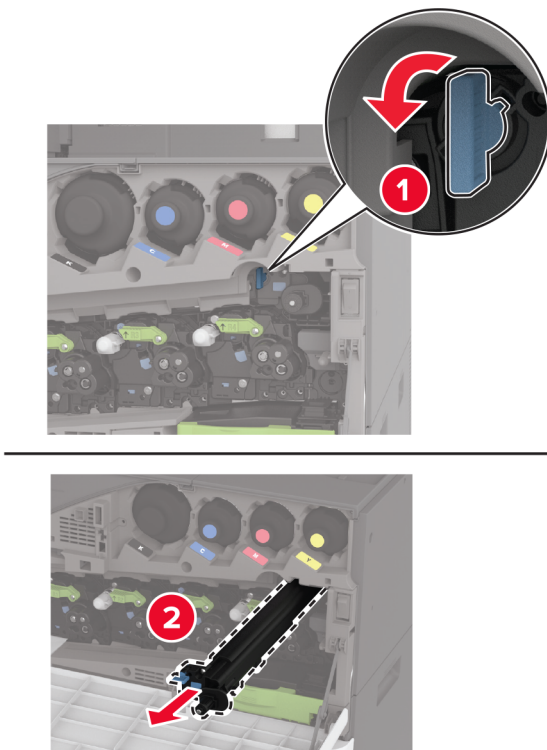

4 Unpack the new transfer module cleaner.

5 Insert the new transfer module cleaner.

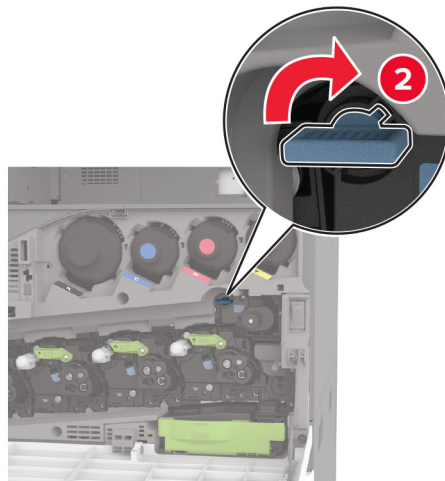
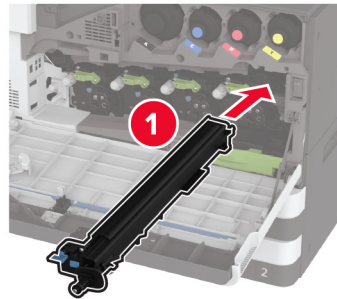

6 Insert the waste toner transfer unit until it *clicks* into place, and then lock it.

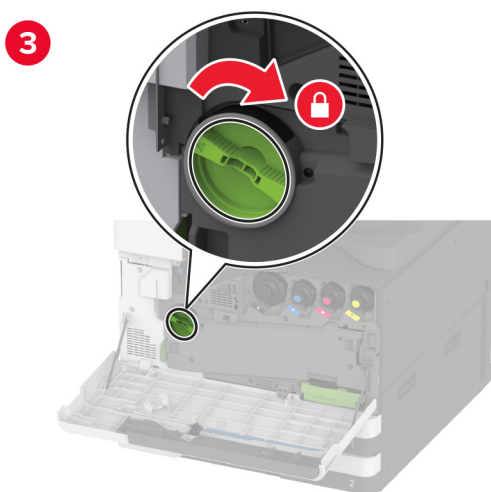
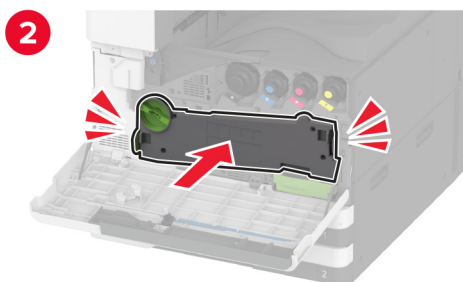
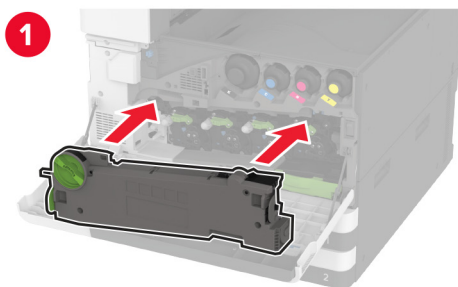

7 Close the front door.

Replacing the tray roller kit

- 1 Turn off the printer.

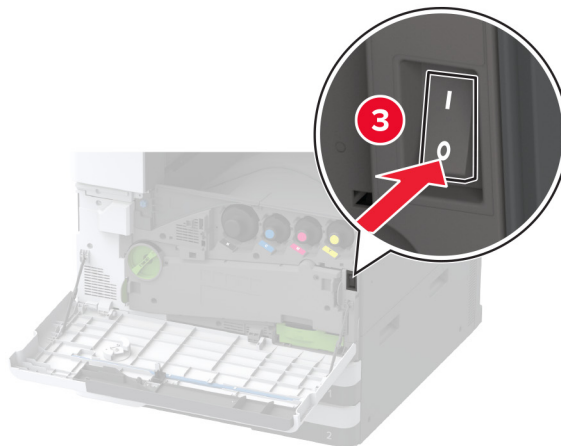
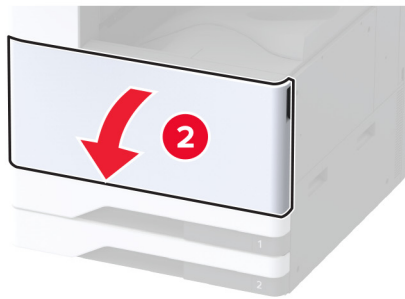
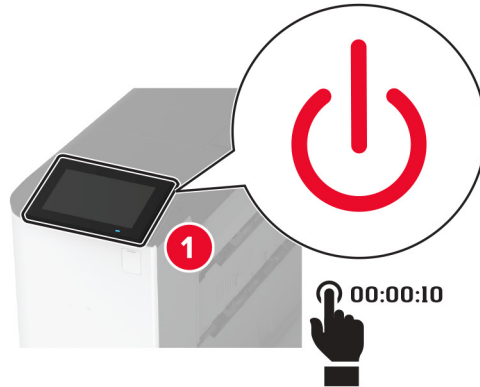

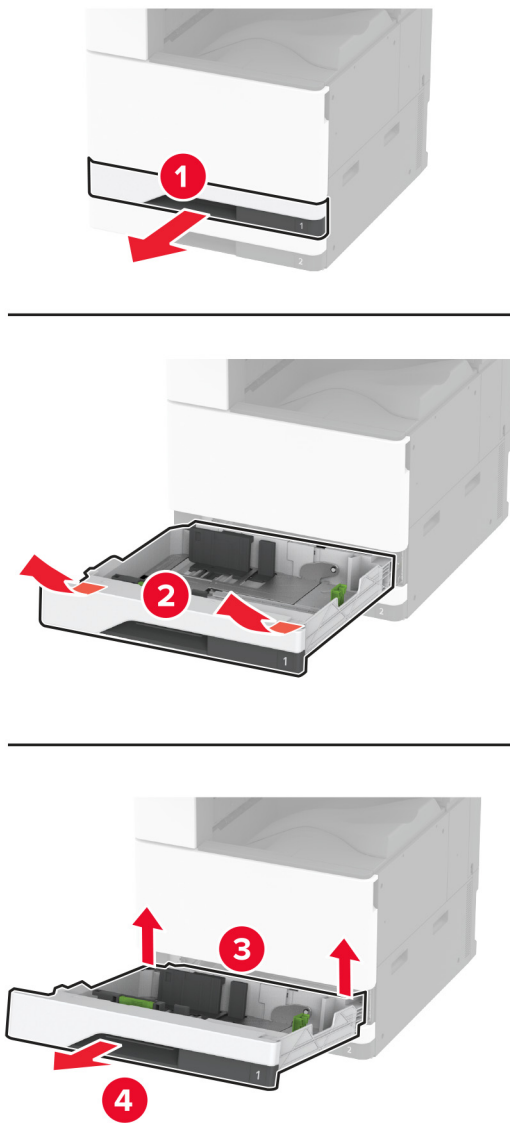
2 Remove the standard tray.**3** Remove the used tray roller kit.

Warning—Potential Damage: To prevent damage from electrostatic discharge, touch any exposed metal frame of the printer before accessing or touching interior areas of the printer.

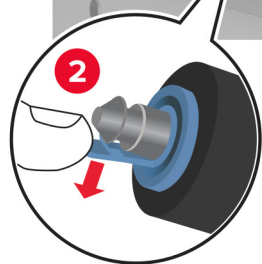
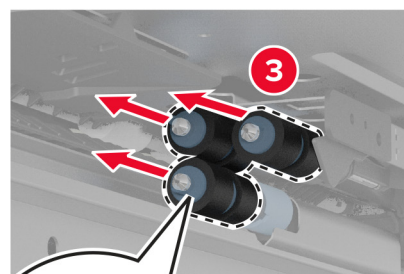
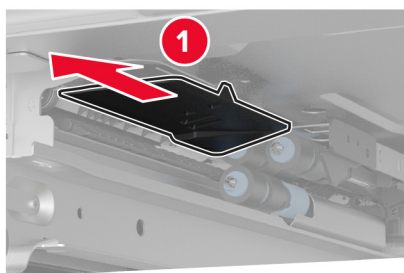
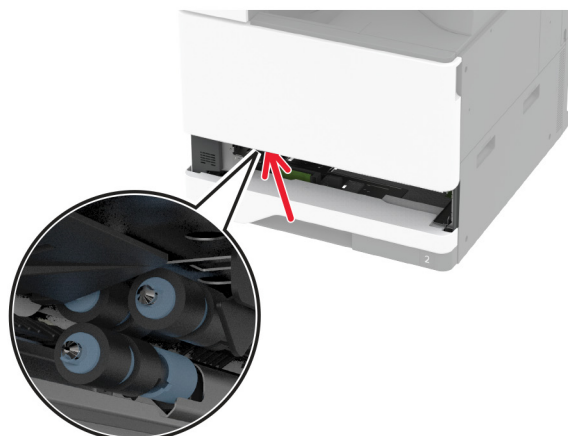

4 Unpack the new tray roller kit.

- 5** Insert the new tray roller kit until it *clicks* into place.

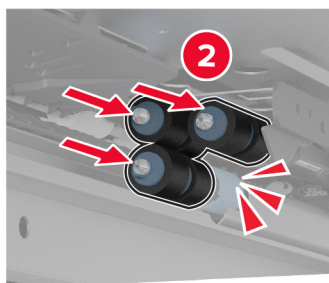
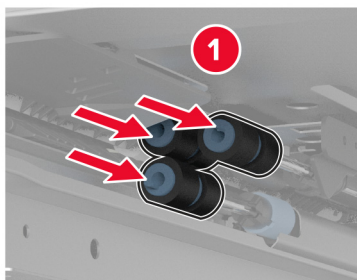

- 6** Insert the tray.

- 7** Turn on the printer.

Replacing the 2000-sheet tray roller kit

- 1 Turn off the printer.

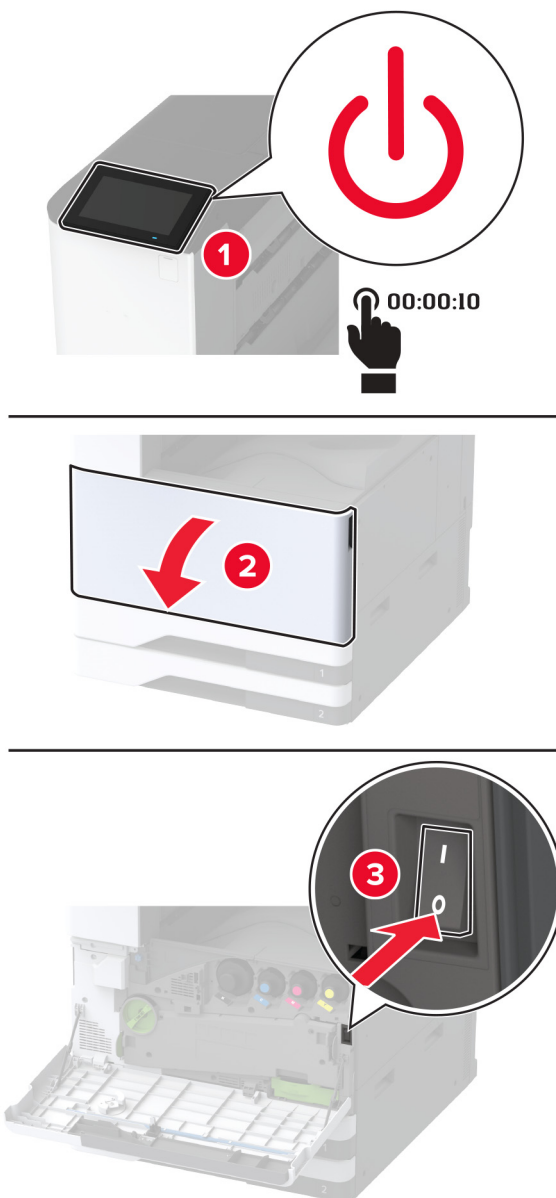

2 Slide the tray to the left.

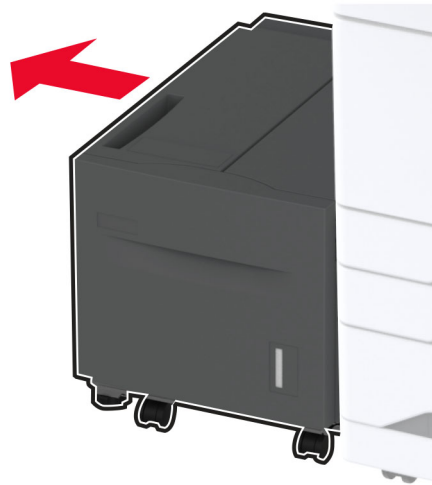

3 Open door J, and then open the roller kit cover.

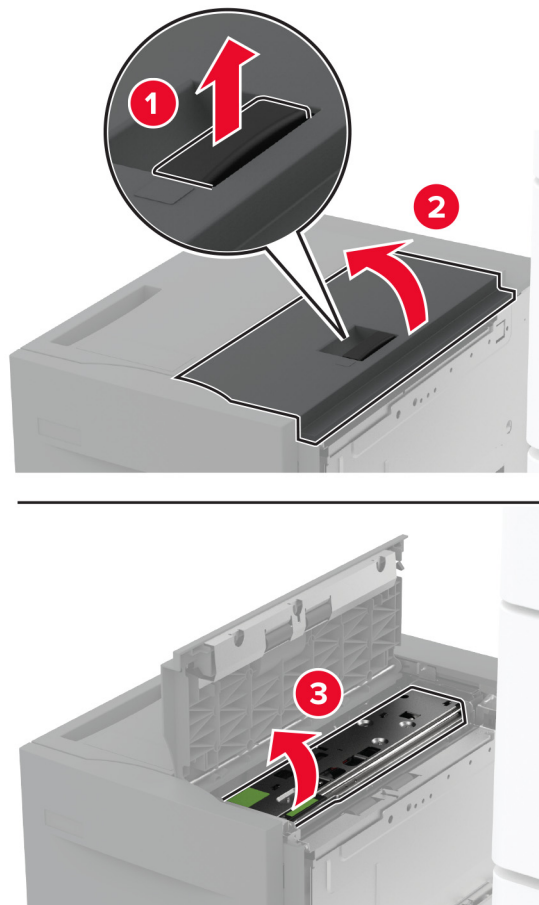

4 Locate and remove the used roller kit.

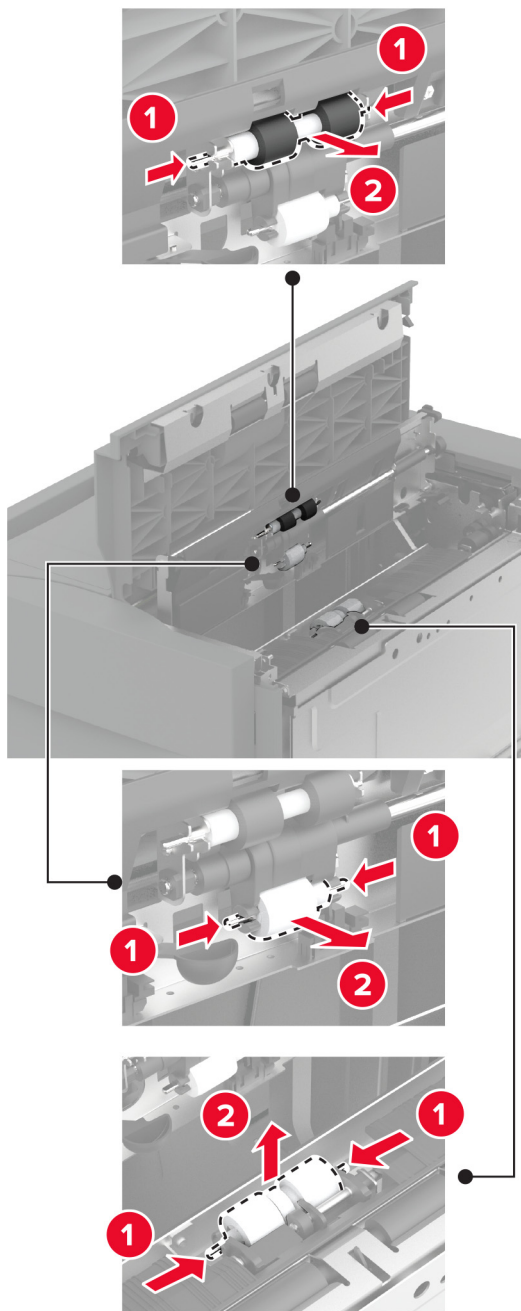

5 Unpack the new roller kit.

6 Insert the new roller kit.

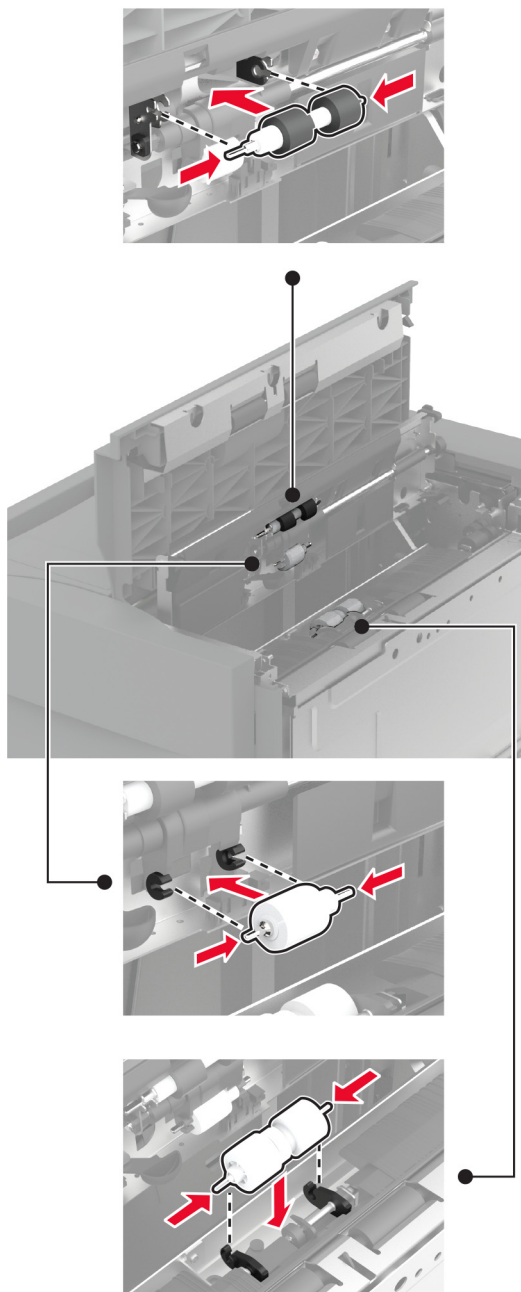

7 Close the roller kit cover, and then close door J.

8 Slide the tray back into place.

9 Turn on the printer.

Replacing the 2000-sheet tandem tray roller kit

In handle C

- 1 Turn off the printer.

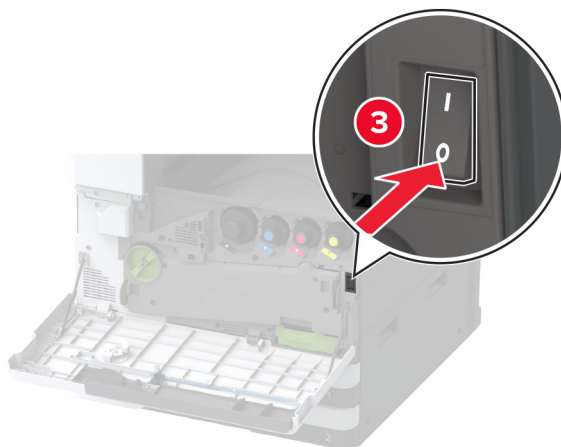
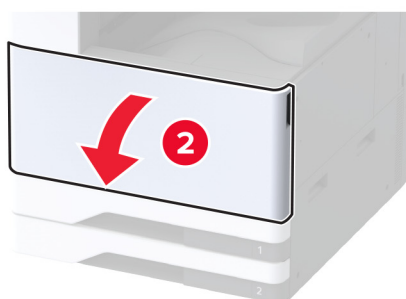
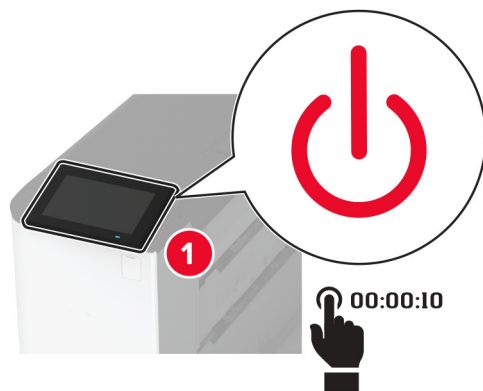

2 Pull out tray 4, and then pull out tray 3.

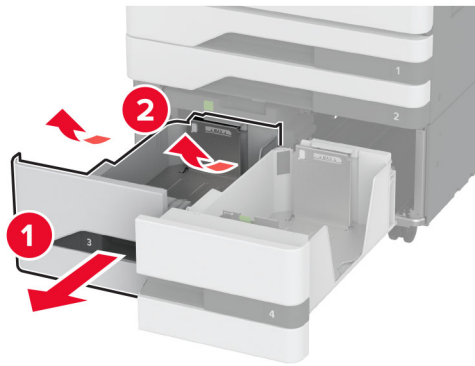
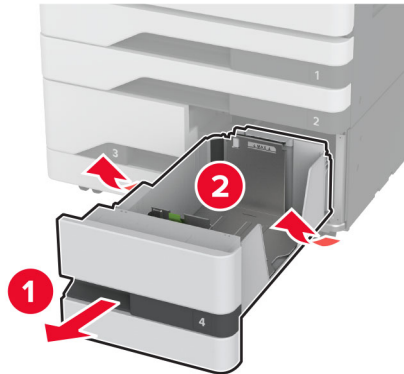

3 Pull out handle C, and then open the inner cover.

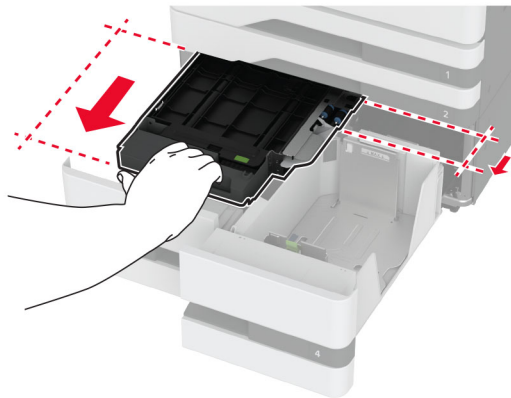

- 4 Open the roller kit cover.

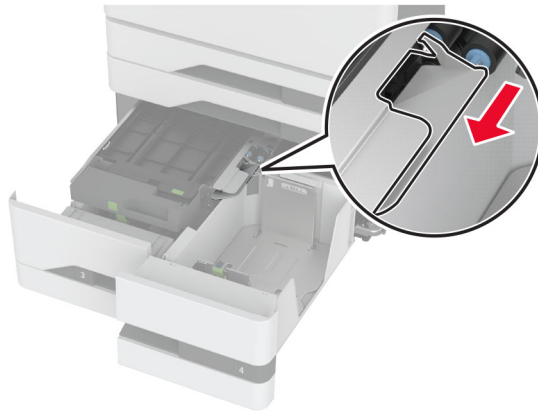

- 5 Remove the used tray roller kit.

Warning—Potential Damage: To prevent damage from electrostatic discharge, touch any exposed metal frame of the printer before accessing or touching interior areas of the printer.

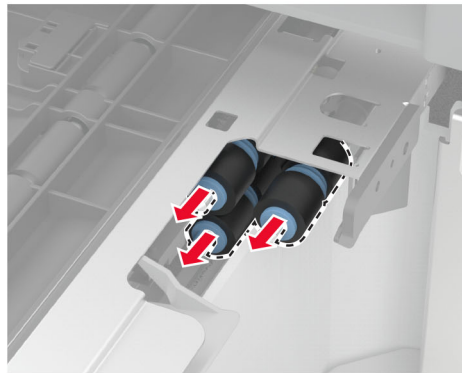
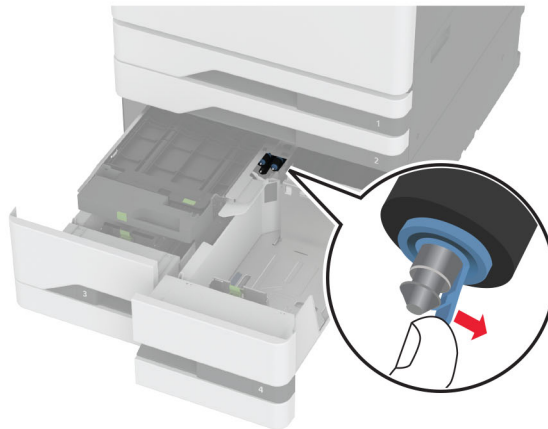

- 6 Unpack the new tray roller kit.

7 Insert the new tray roller kit until it *clicks* into place.

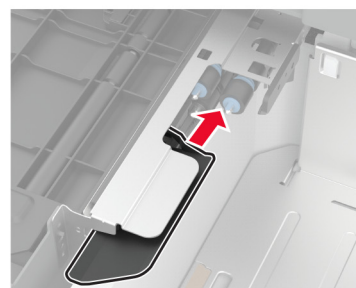
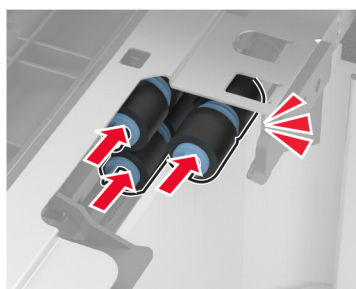
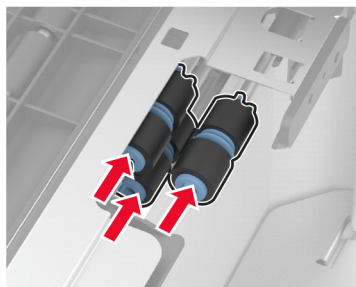

8 Close the roller kit cover.

9 Close the inner cover, and then insert handle C.

10 Insert trays 3 and 4.

11 Turn on the printer.

In tray 3

- 1 Turn off the printer.

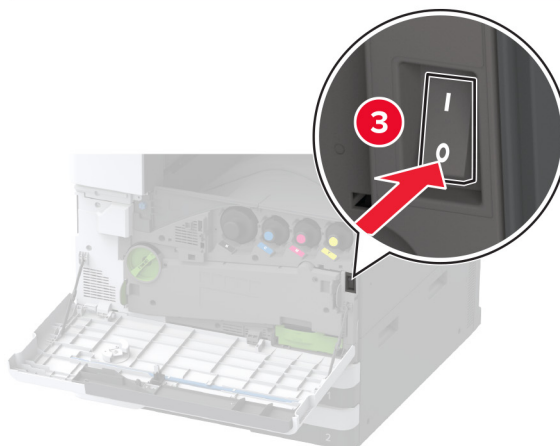
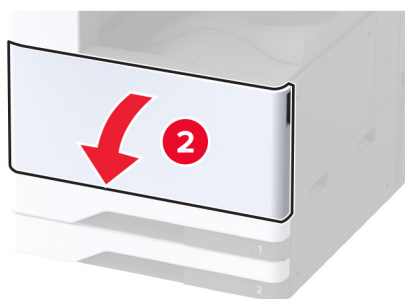
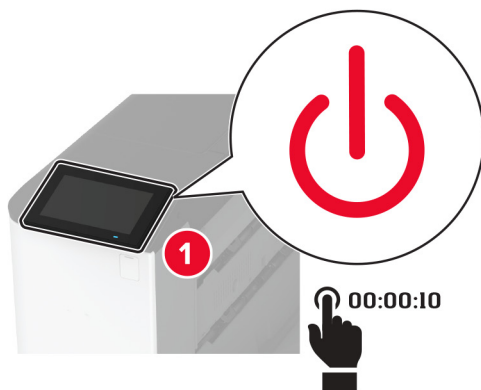

2 Remove tray 1, and then remove tray 2.

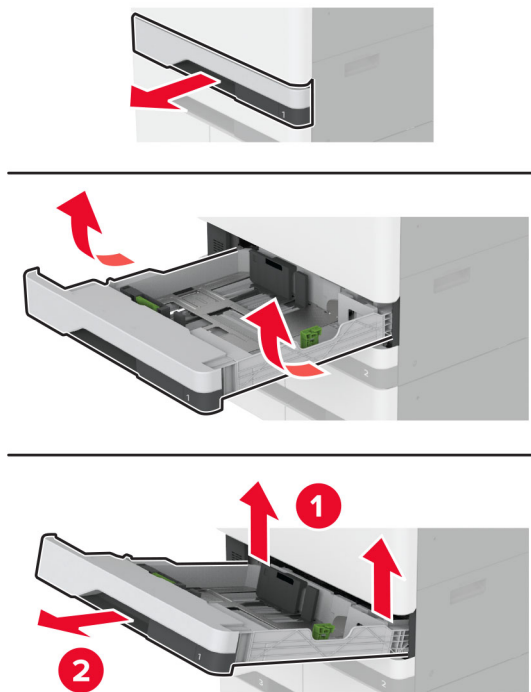

3 Pull out trays 3 and 4.

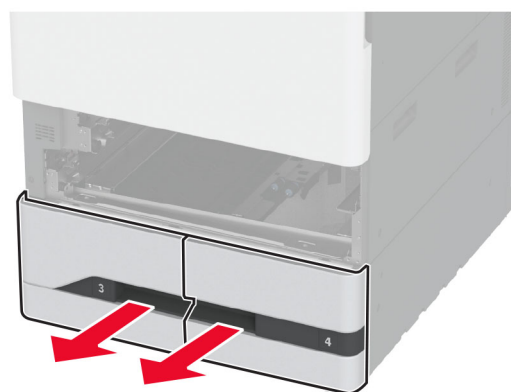

- 4 Pull out handle C.

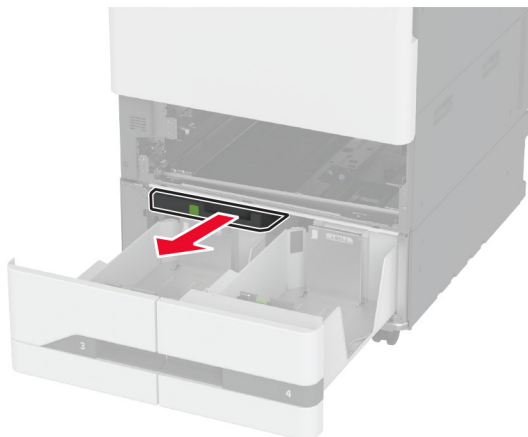

- 5 Remove the used tray roller kit.

Warning—Potential Damage: To prevent damage from electrostatic discharge, touch any exposed metal frame of the printer before accessing or touching interior areas of the printer.

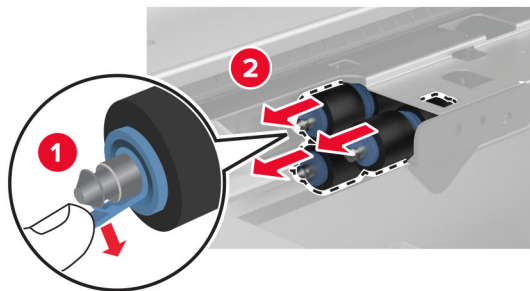
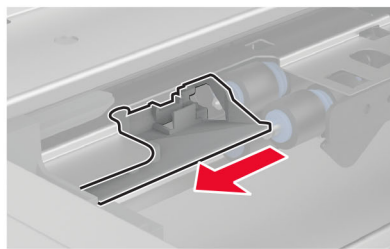
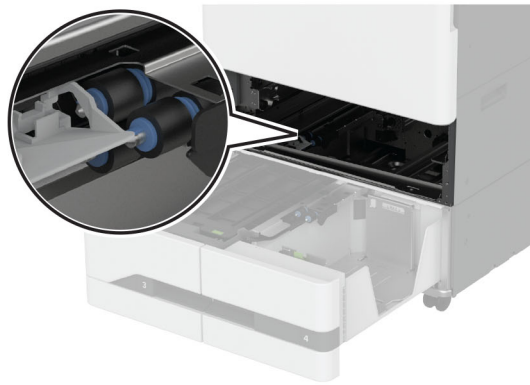

6 Insert the new tray roller kit until it *clicks* into place.

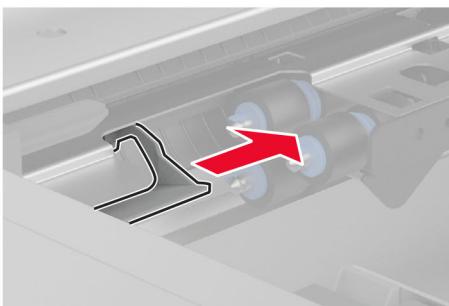
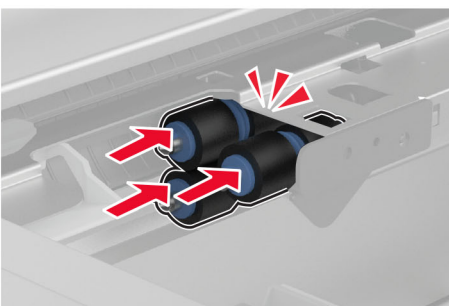
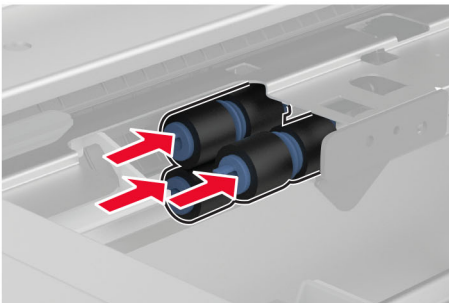

7 Insert handle C.

8 Insert trays 3 and 4.

9 Insert trays 1 and 2.

10 Turn on the printer.

Replacing the second transfer roller

- 1 Turn off the printer.

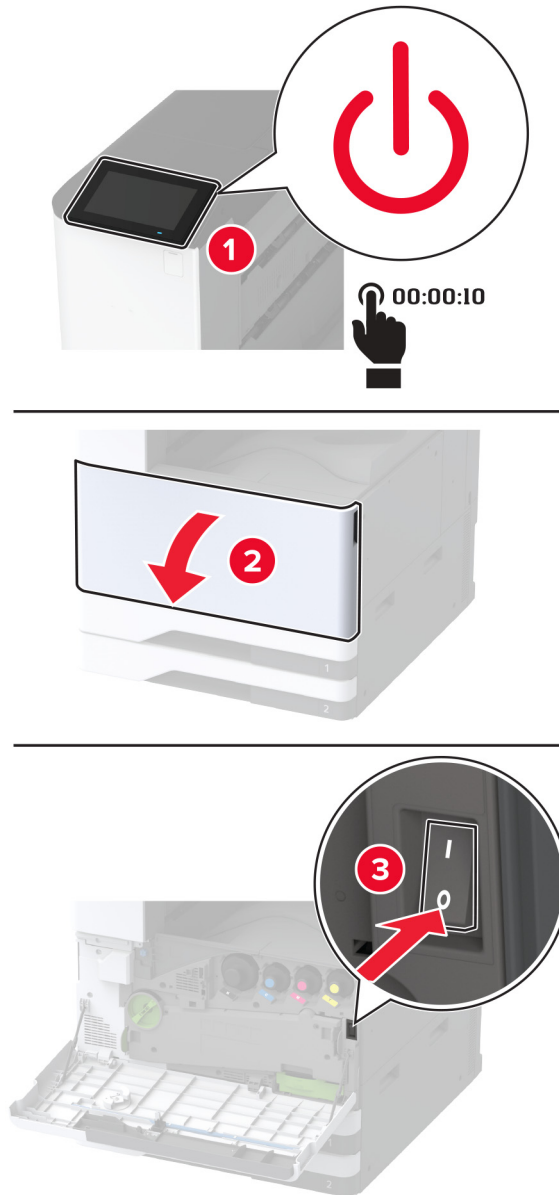

- 2 Open door A.

 **CAUTION—HOT SURFACE:** The inside of the printer might be hot. To reduce the risk of injury from a hot component, allow the surface to cool before touching it.

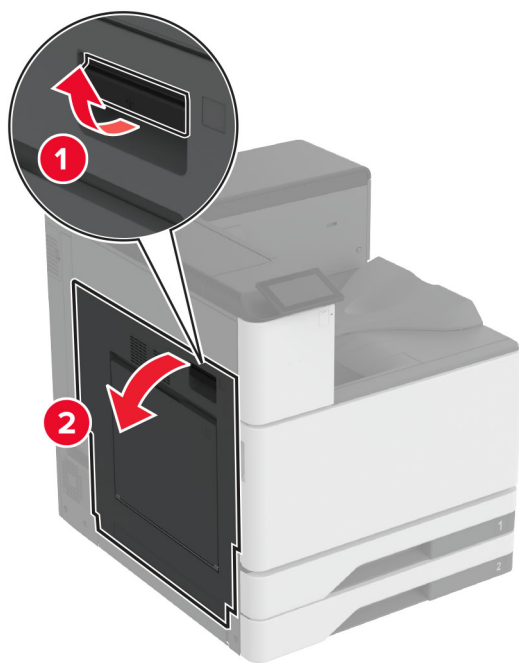

3 Remove the used second transfer roller.

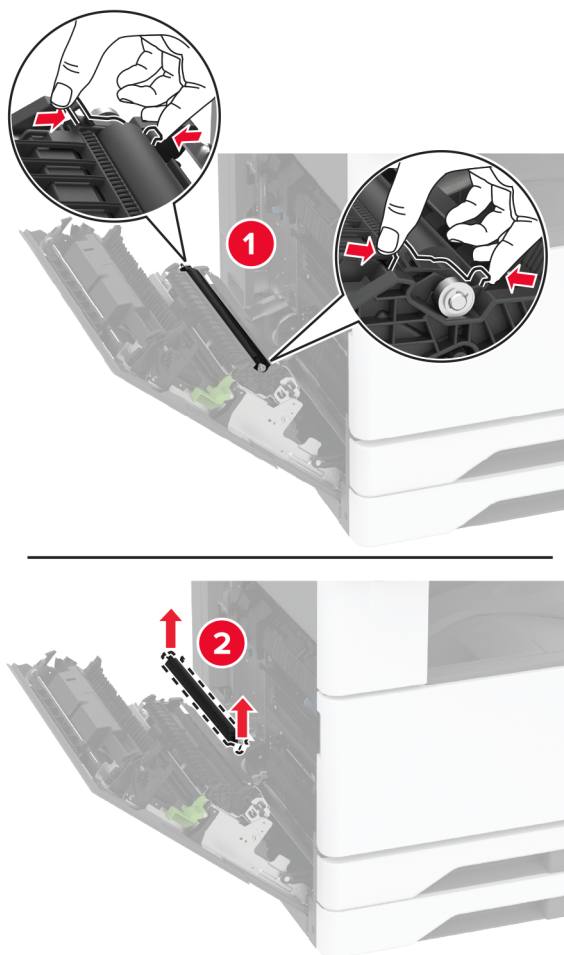

- 4 Unpack the new second transfer roller.
- 5 Insert the new second transfer roller.

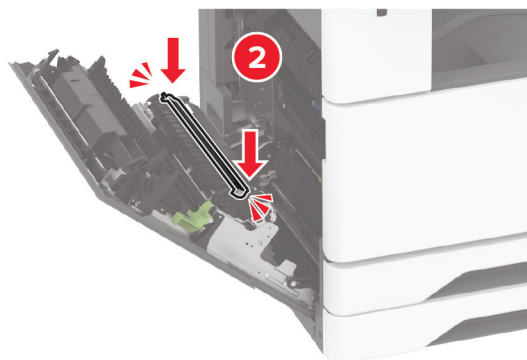
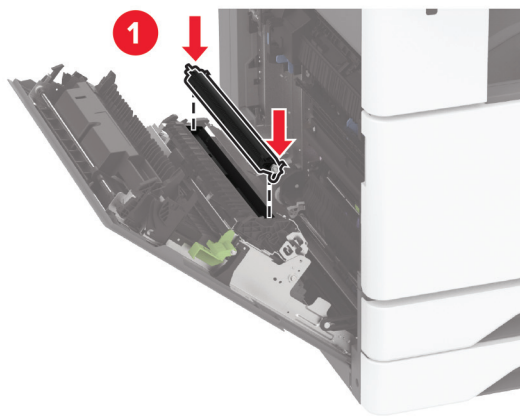

- 6 Close the door.
- 7 Turn on the printer.

Replacing the lower rear connector cover

- 1 Remove the used lower rear connector cover.

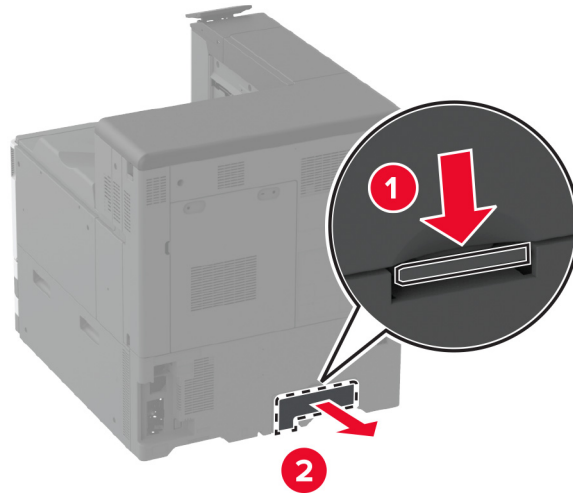

- 2 Unpack the new lower rear connector cover.
- 3 Insert the new lower rear connector cover until it *clicks* into place.

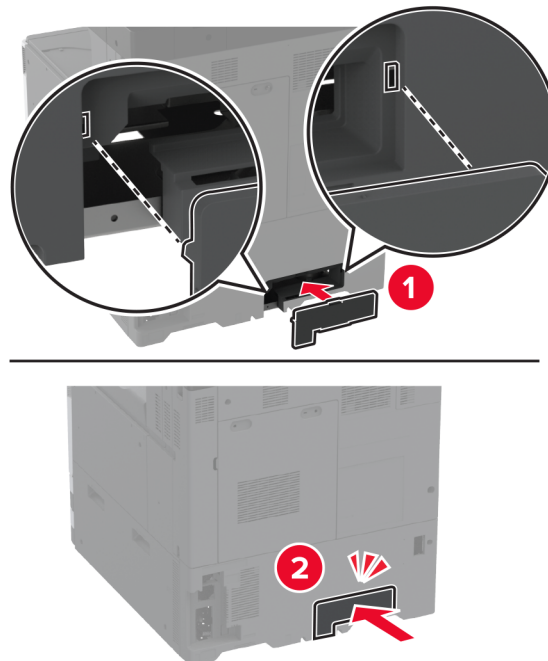

Replacing the waste toner bottle

- 1 Open the front door.

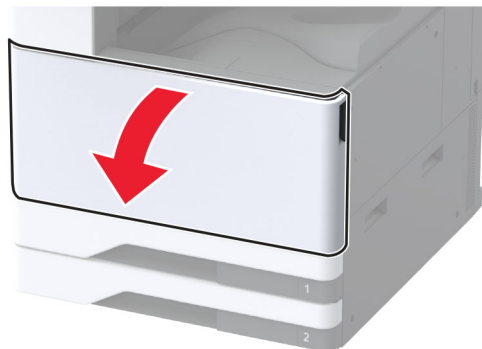

2 Remove the waste toner transfer unit.

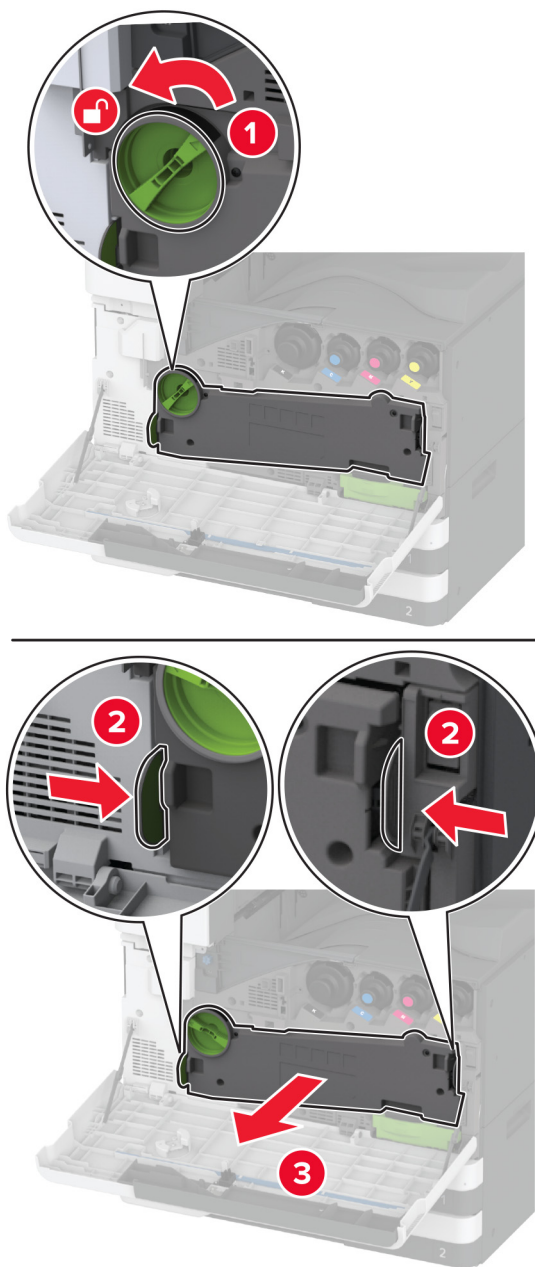

Note: To avoid spilling the toner, place the unit in an upright position.

3 Remove the printhead wiper, and then clean the printhead lenses.

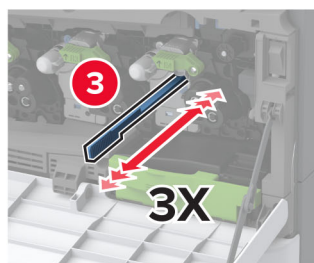
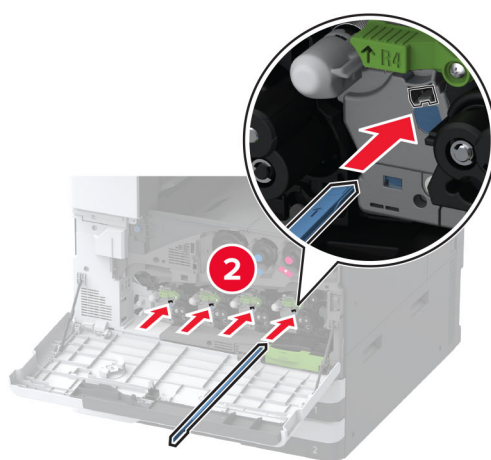
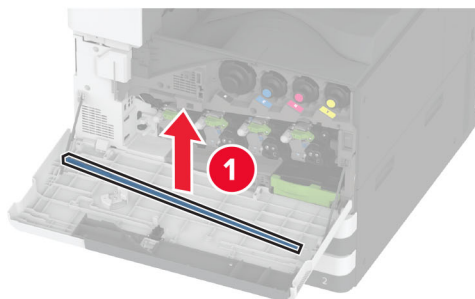

4 Put the printhead wiper back into place.

5 Insert the waste toner transfer unit until it *clicks* into place, and then lock it.

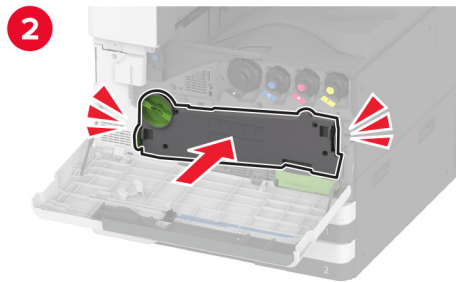
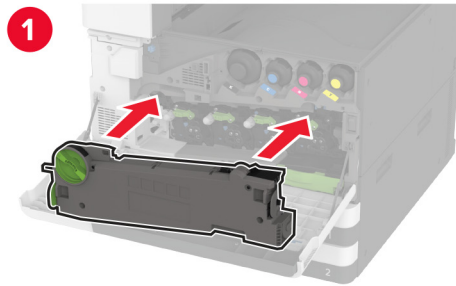

6 Remove the used waste toner bottle.

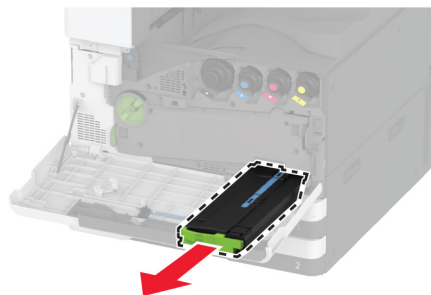

7 Unpack the new waste toner bottle.

8 Insert the new waste toner bottle until it *clicks* into place, and then close the door.

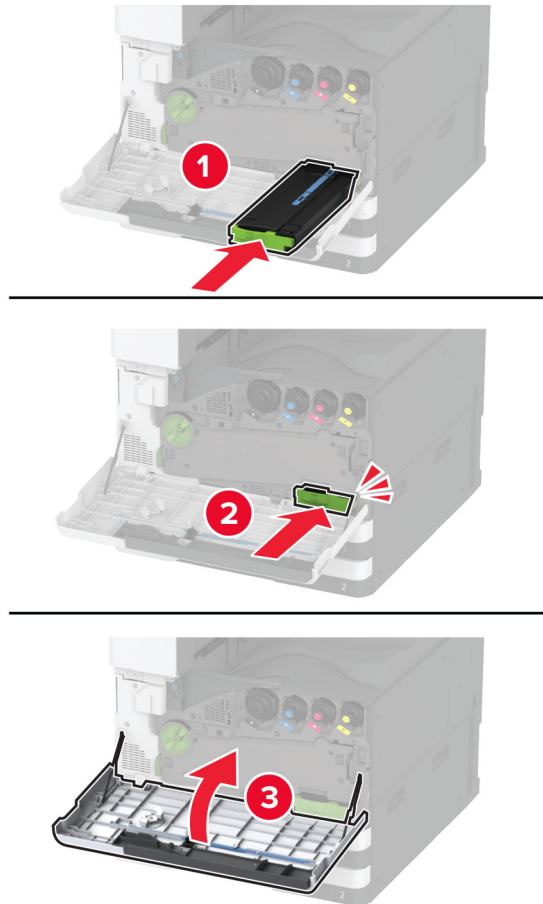

Replacing the waste toner transfer unit

1 Open the front door.

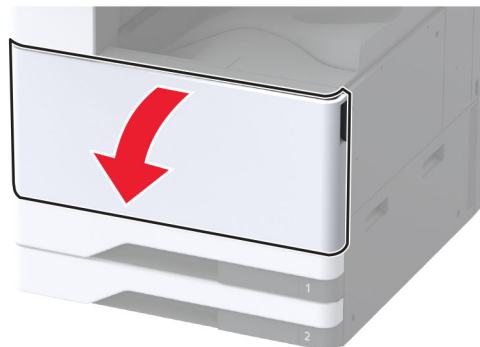

2 Remove the used waste toner transfer unit.

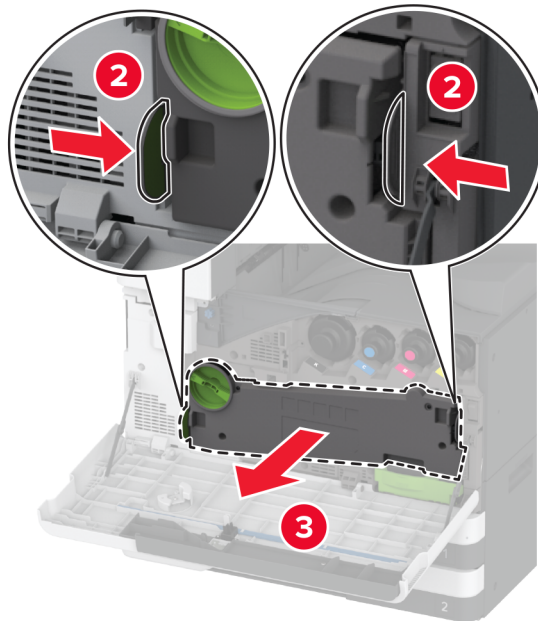
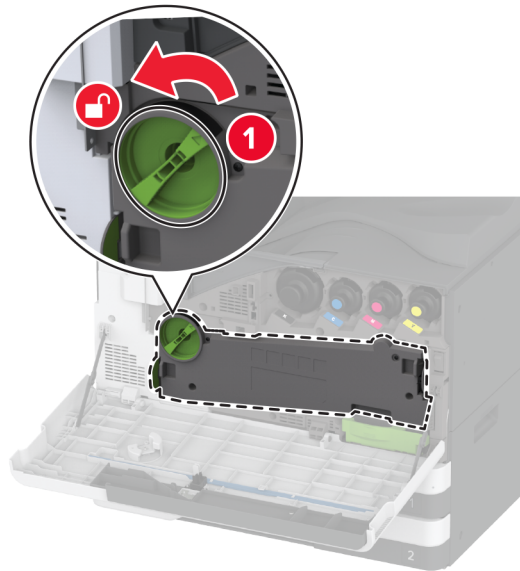

Note: To avoid spilling the toner, place the unit in an upright position.

3 Unpack the new waste toner transfer unit.

4 Insert the new waste toner transfer unit until it *clicks* into place, and then lock it.

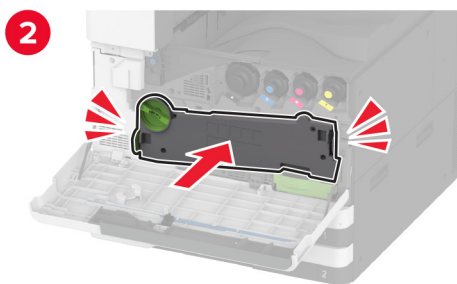
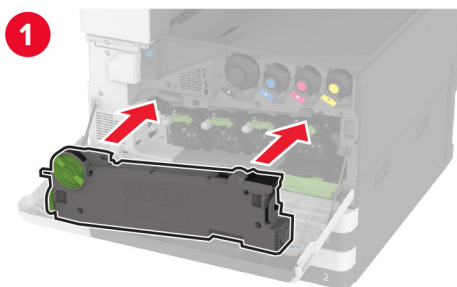

5 Close the front door.

Replacing the small cover in the tray insert

- 1 Pull out the tray.
- 2 Remove the used small cover.

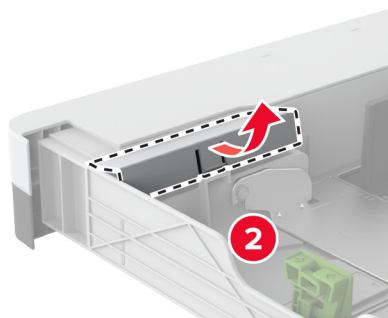
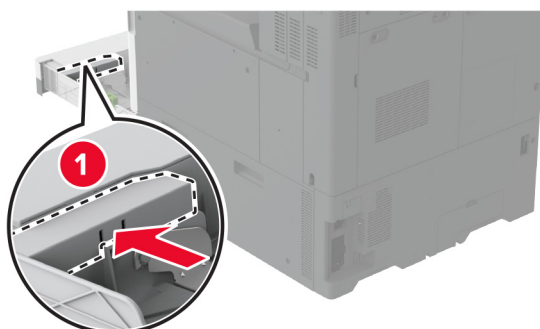

- 3 Unpack the new small cover.

4 Insert the new small cover.

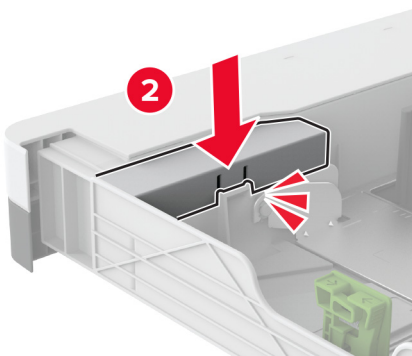
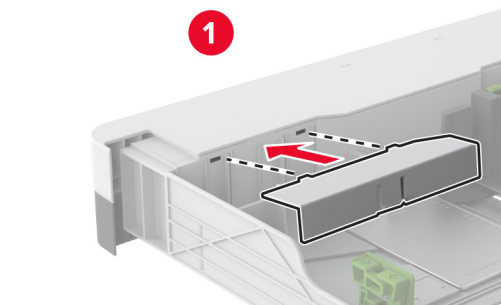

5 Insert the tray.

Replacing the B4 paper guide in the tray insert

- 1 Pull out the tray.
- 2 Remove the used B4 paper guide.

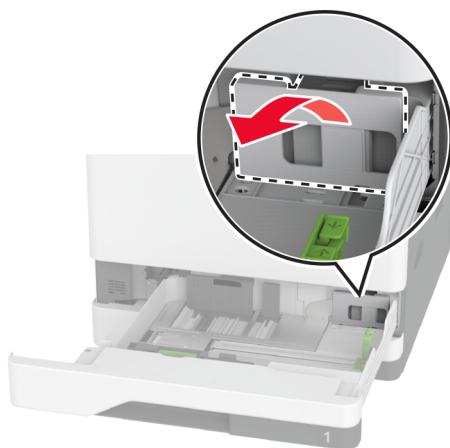
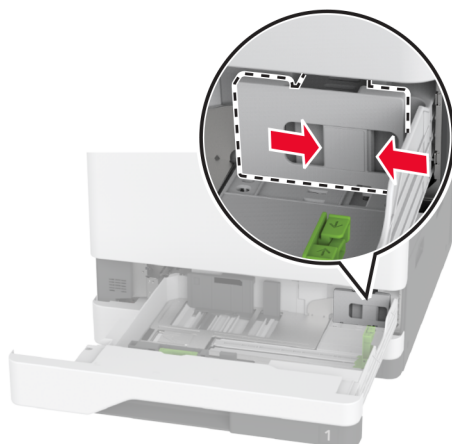

- 3 Unpack the new B4 paper guide.

- 4 Insert the new B4 paper guide.

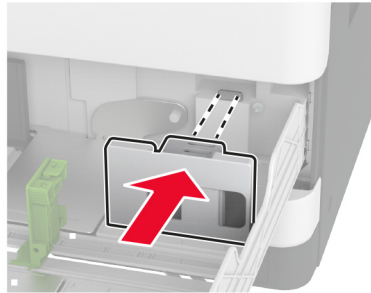

- 5 Insert the tray.

Replacing the hole punch box in the booklet finisher

- 1 Open the booklet finisher door.

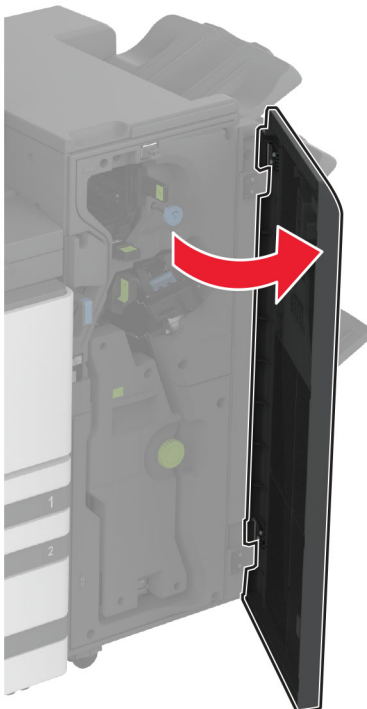

2 Remove the used hole punch box.

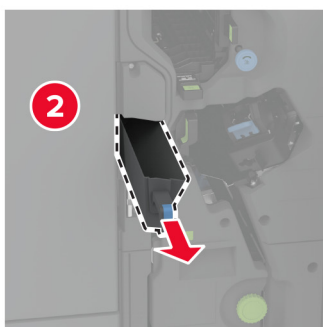
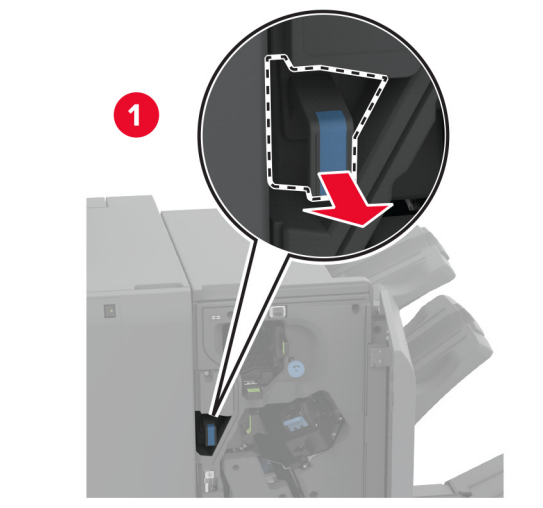

3 Unpack the new hole punch box.

4 Insert the new hole punch box.



5 Close the booklet finisher door.

Replacing the trifold/Z-fold finisher bin

- 1 Turn off the printer.

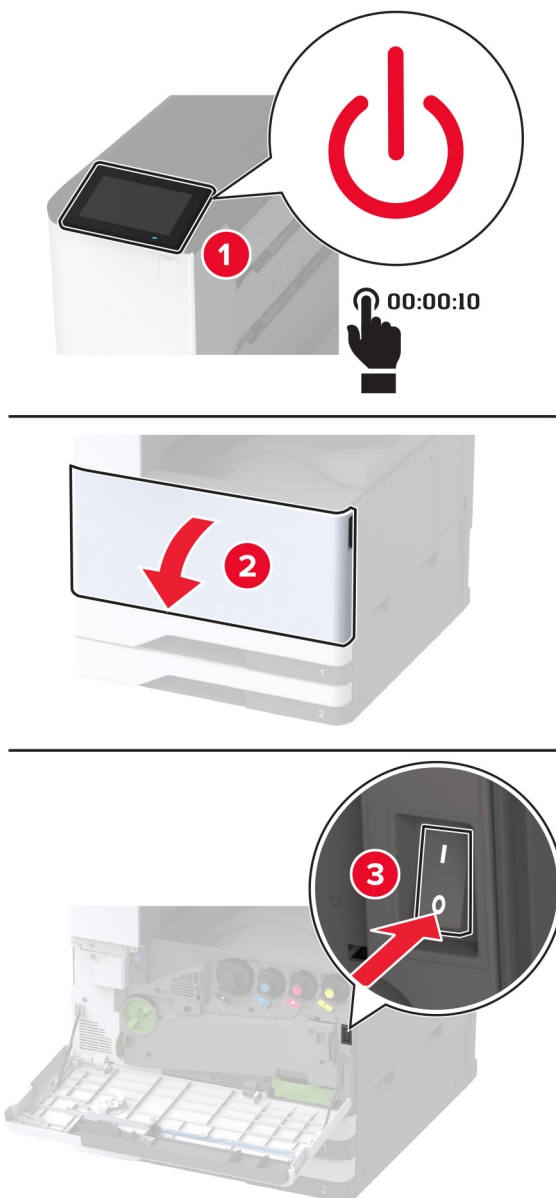

2 Open the trifold/Z-fold finisher door.

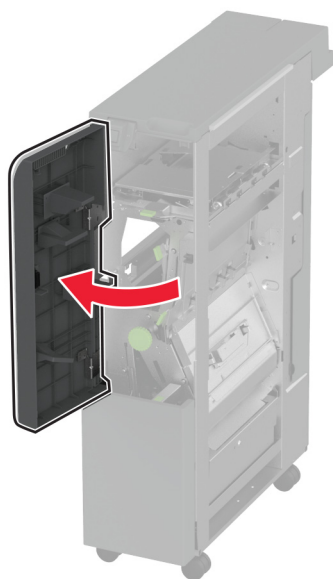

3 Remove the used finisher bin.

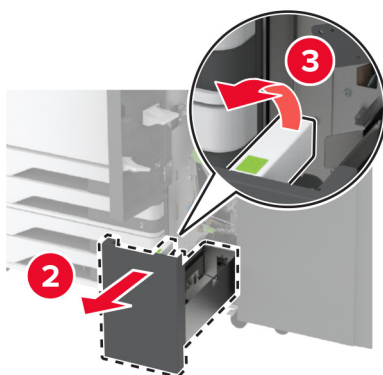
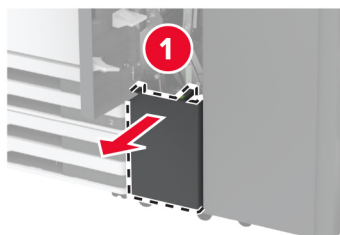

4 Unpack the new finisher bin.

- 5 Insert the new finisher bin.

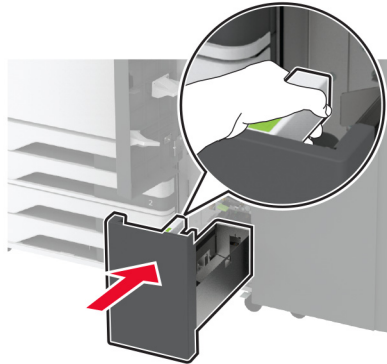

- 6 Close the finisher door.

- 7 Turn on the printer.

Replacing the paper bail

- 1 Pinch the left side of the paper bail to unlock it.

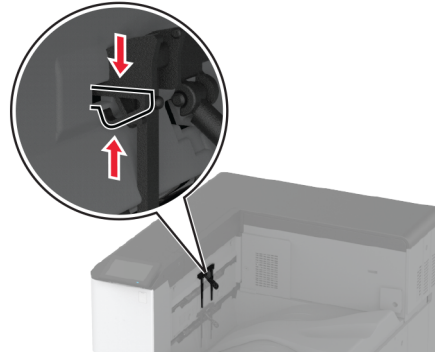

- 2 Remove the used paper bail.

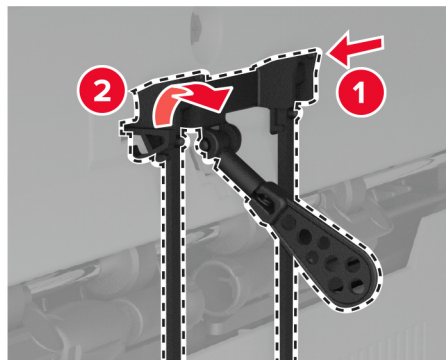

- 3 Unpack the new paper bail.

4 Insert the new paper bail until it *clicks* into place.

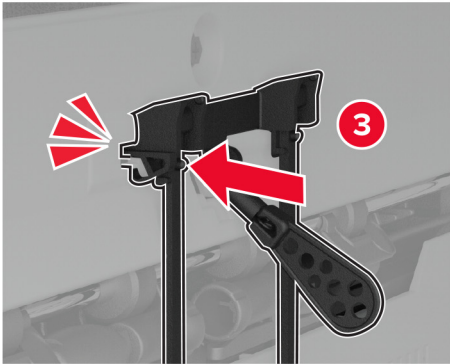
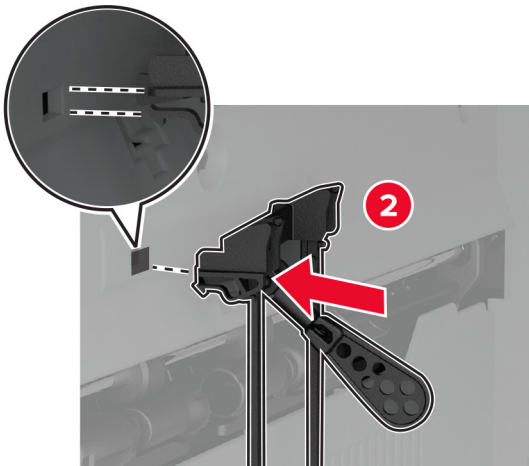
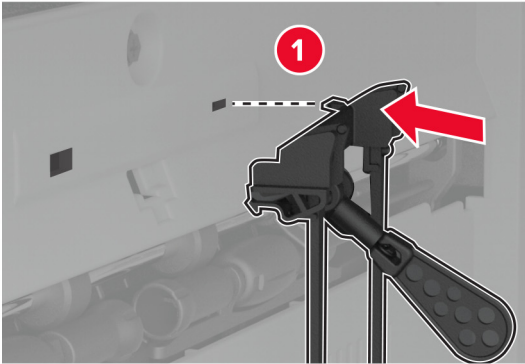

Replacing the dual catch bin

- 1 Remove the used dual catch bin.

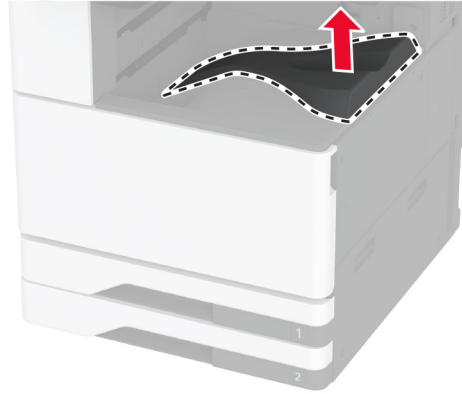

- 2 Unpack the new dual catch bin.
- 3 Attach the new dual catch bin until it *clicks* into place.

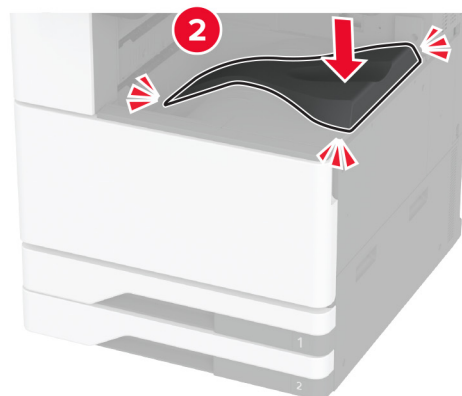
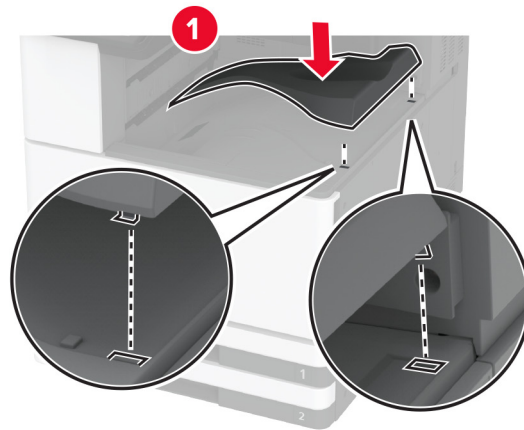

Replacing the controller board access cover

- 1 Remove the rear ports cover.

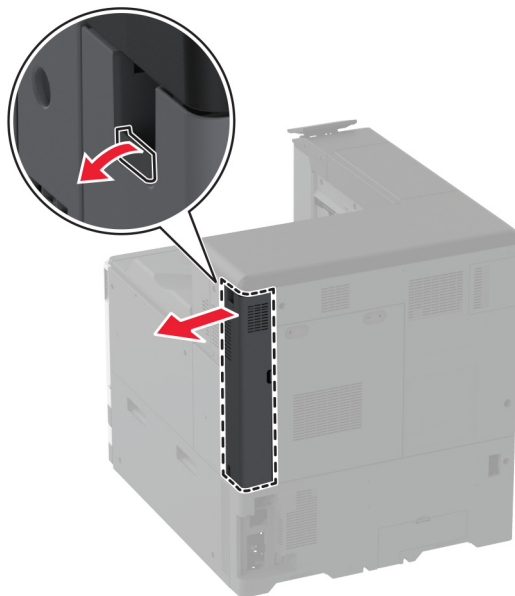

2 Using a flat-head screwdriver, remove the used controller board access cover.

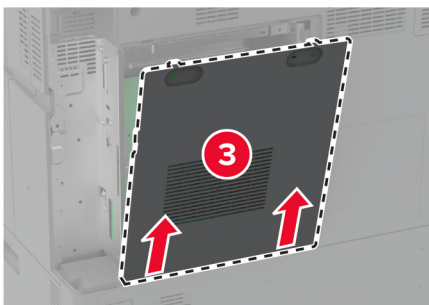
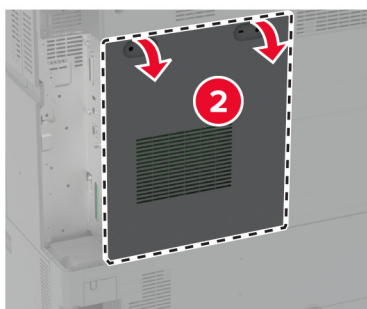
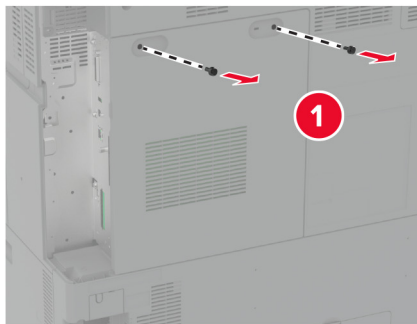

3 Unpack the new controller board access cover.

4 Attach the new controller board access cover.

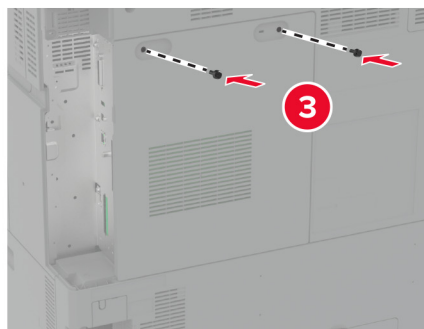
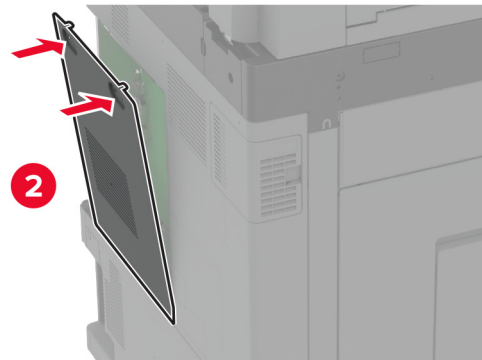
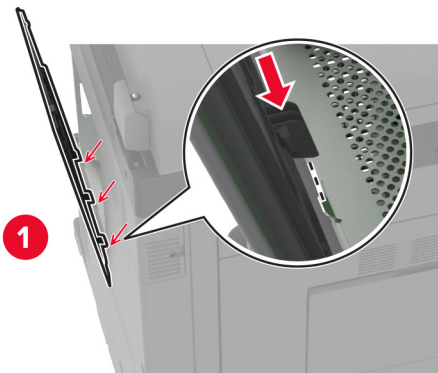

- 5 Attach the rear ports cover.

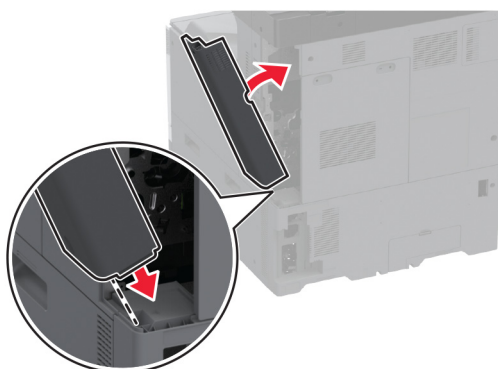

Replacing the rear ports cover

- 1 Remove the used rear ports cover.

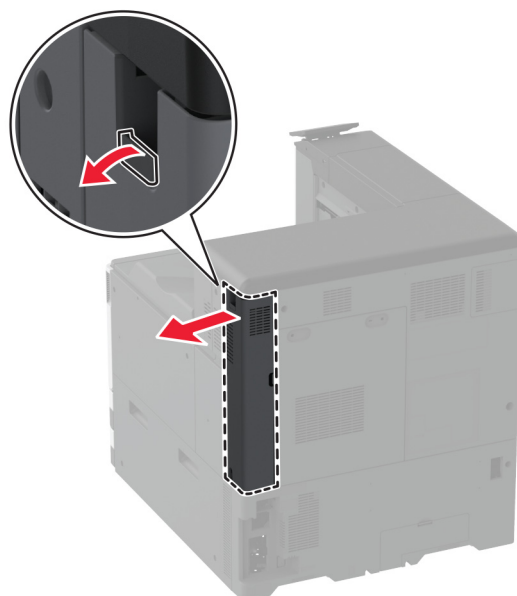

- 2 Unpack the new rear ports cover.

3 Attach the new rear ports cover.

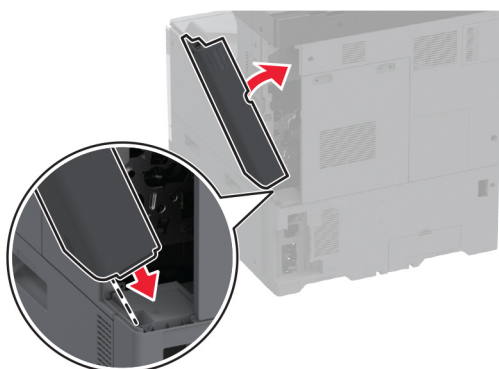

Replacing the R9 rear cover

1 Remove the used R9 rear cover.

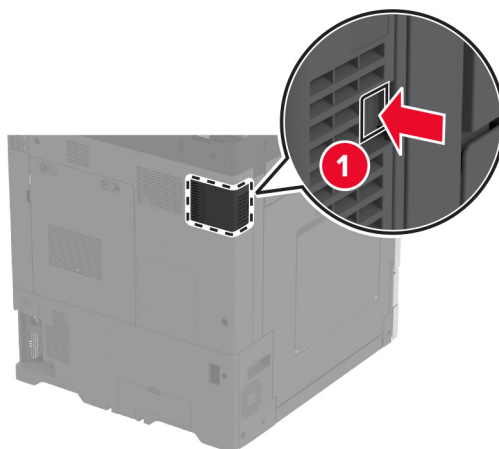

2 Unpack the new R9 rear cover.

- 3 Attach the new R9 rear cover until it *clicks* into place.

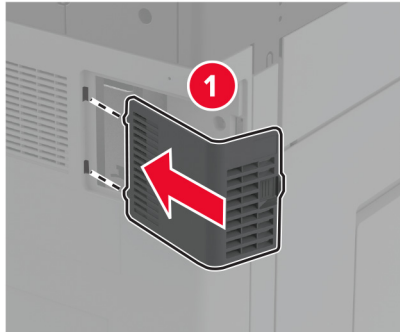

Replacing the staple cartridge unit

Replacing the staple cartridge in the staple finisher

- 1 Open the finisher door.

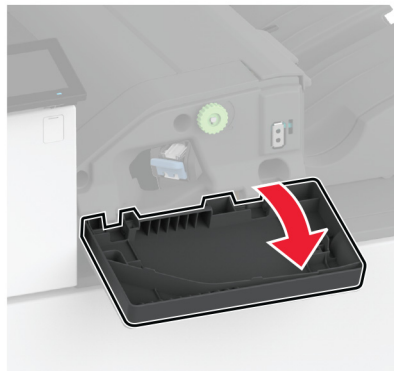

2 Remove the staple cartridge holder.

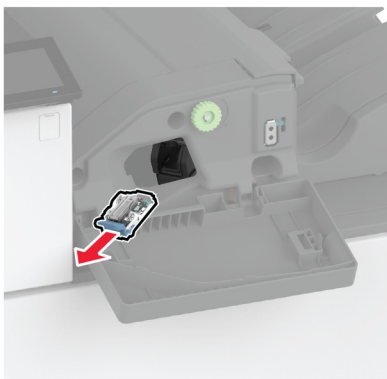

3 Remove the empty staple cartridge.

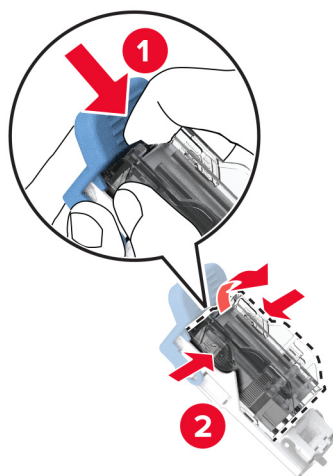

4 Unpack the new staple cartridge.

5 Insert the new staple cartridge into the holder until it *clicks* into place..

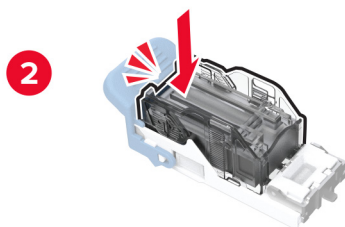
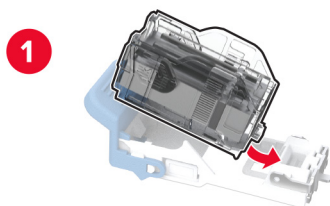

6 Insert the staple cartridge holder until it *clicks* into place.



7 Close the door.

Replacing the staple cartridge in the staple, hole punch finisher

- 1 Open the finisher door.



- 2 Remove the staple cartridge holder.

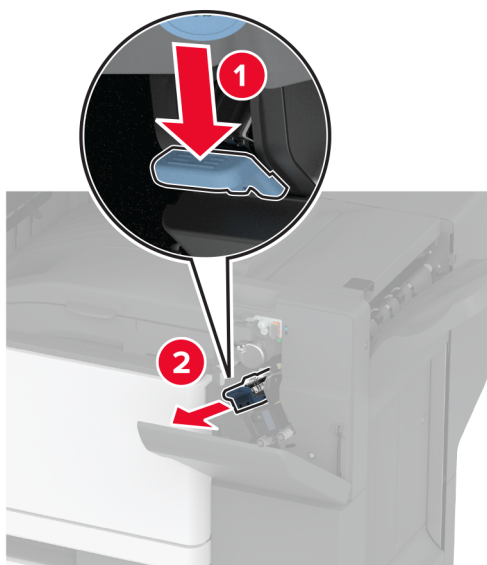

3 Remove the empty staple cartridge.

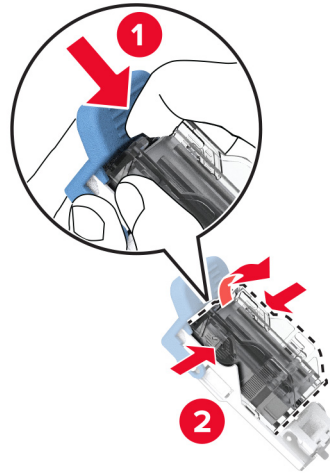

4 Unpack the new staple cartridge.

5 Insert the new staple cartridge until it *clicks* into place.

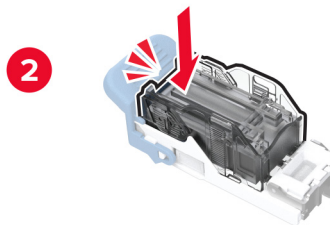
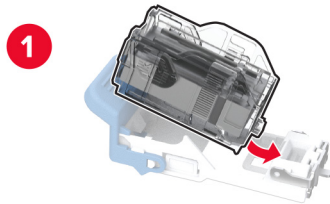

6 Insert the staple cartridge holder.



7 Close the door.

Replacing the standard staple cartridge holder

1 Open the finisher door.

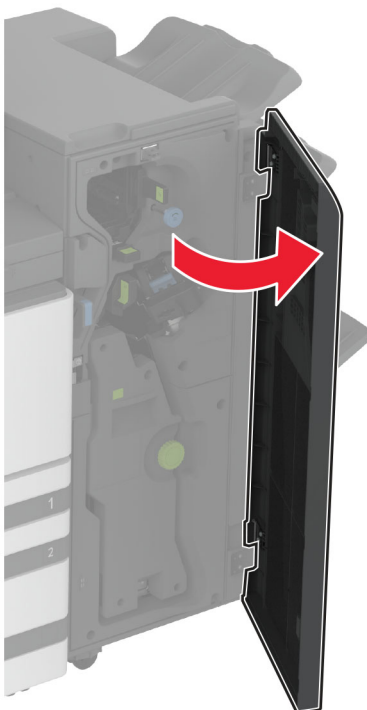

2 Remove the used staple cartridge holder.

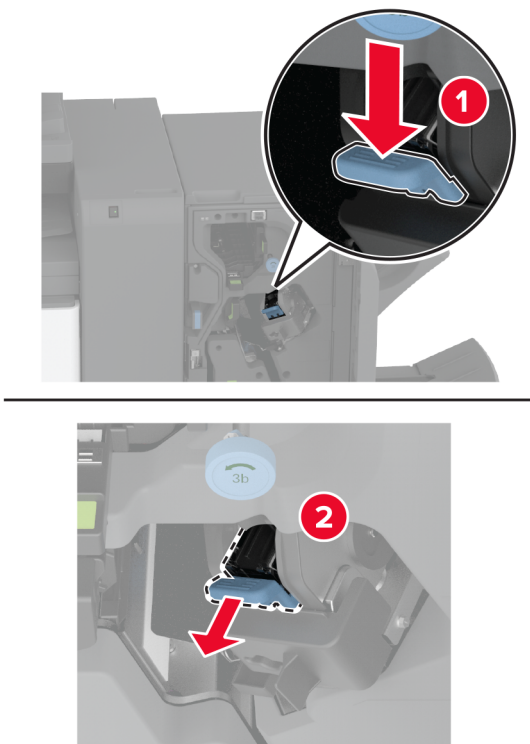

3 Remove the staple cartridge.

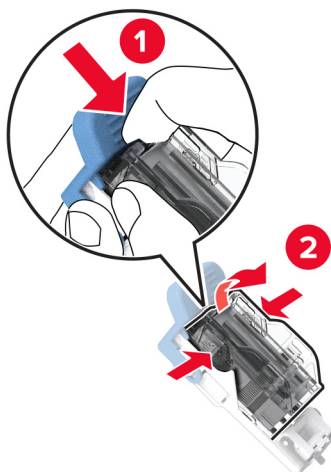

4 Unpack the new staple cartridge holder.

5 Insert the staple cartridge into the new staple cartridge holder until it *clicks* into place.

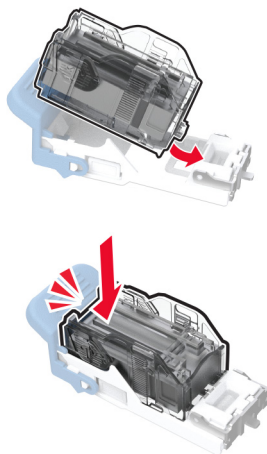

6 Insert the new staple cartridge holder until it *clicks* into place.



7 Close the finisher door.

Replacing the staple cartridge holder in the booklet finisher

- 1 Open the finisher door, and then pull out the booklet maker.

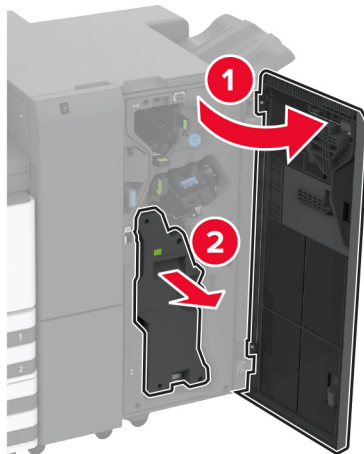

- 2 Remove the used staple cartridge holder.

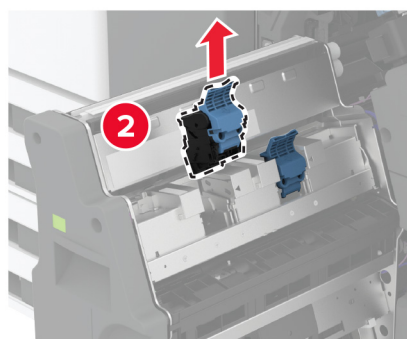
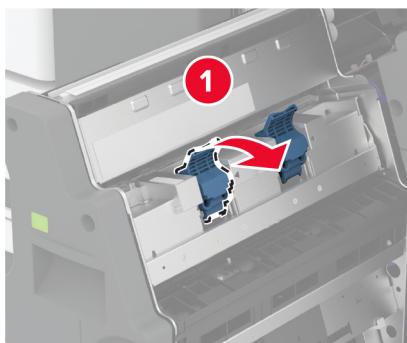

3 Remove the staple cartridge.

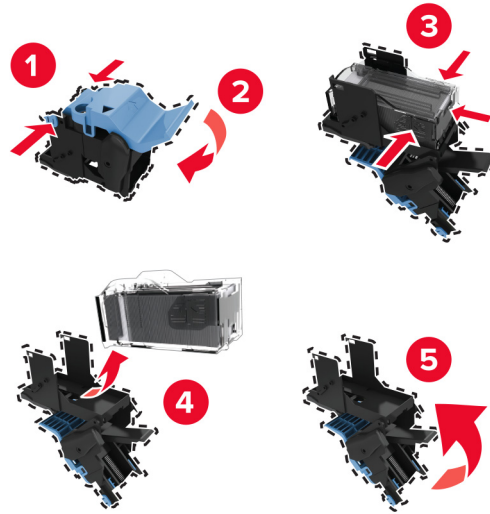

4 Unpack the new staple cartridge holder.

5 Insert the staple cartridge into the new staple cartridge holder.



- 6 Insert the new staple cartridge holder.

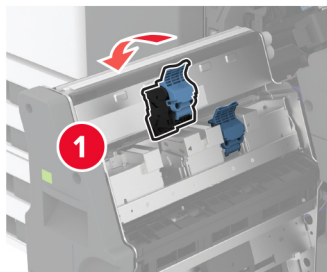

- 7 Insert the booklet maker, and then close the finisher door.

Resetting the supply usage counters

- 1 From the home screen, touch **Settings > Device > Maintenance > Configuration Menu > Supply Usage And Counters**.
- 2 Select the counter that you want to reset.

Warning—Potential Damage: Supplies and parts without Return Program agreement terms may be reset and remanufactured. However, the manufacturer's warranty does not cover any damage caused by non-genuine supplies or parts. Resetting counters on the supply or part without proper remanufacturing can cause damage to your printer. After resetting the supply or part counter, your printer may display an error indicating the presence of the reset item.

Cleaning printer parts

Cleaning the printer

 **CAUTION—SHOCK HAZARD:** To avoid the risk of electrical shock when cleaning the exterior of the printer, unplug the power cord from the electrical outlet and disconnect all cables from the printer before proceeding.

Notes:

- Perform this task after every few months.
- Damage to the printer caused by improper handling is not covered by the printer warranty.

- 1 Turn off the printer, and then unplug the power cord from the electrical outlet.
- 2 Remove paper from the standard bin and multipurpose feeder.
- 3 Remove any dust, lint, and pieces of paper around the printer using a soft brush or vacuum.
- 4 Wipe the outside of the printer with a damp, soft, lint-free cloth.

Notes:

- Do not use household cleaners or detergents, as they may damage the finish of the printer.
- Make sure that all areas of the printer are dry after cleaning.

- 5 Connect the power cord to the electrical outlet, and then turn on the printer.

 **CAUTION—POTENTIAL INJURY:** To avoid the risk of fire or electrical shock, connect the power cord to an appropriately rated and properly grounded electrical outlet that is near the product and easily accessible.

Cleaning the touch screen

 **CAUTION—SHOCK HAZARD:** To avoid the risk of electric shock when cleaning the exterior of the printer, unplug the power cord from the electrical outlet and disconnect all cables from the printer before proceeding.

- 1 Turn off the printer, and then unplug the power cord from the electrical outlet.
- 2 Using a damp, soft, lint-free cloth, wipe the touch screen.

Notes:

- Do not use household cleaners or detergents, as they may damage the touch screen.
- Make sure that the touch screen is dry after cleaning.

- 3 Connect the power cord to the electrical outlet, and then turn on the printer.

 **CAUTION—POTENTIAL INJURY:** To avoid the risk of fire or electrical shock, connect the power cord to an appropriately rated and properly grounded electrical outlet that is near the product and easily accessible.

Cleaning the tray roller kit

- 1 Turn off the printer.

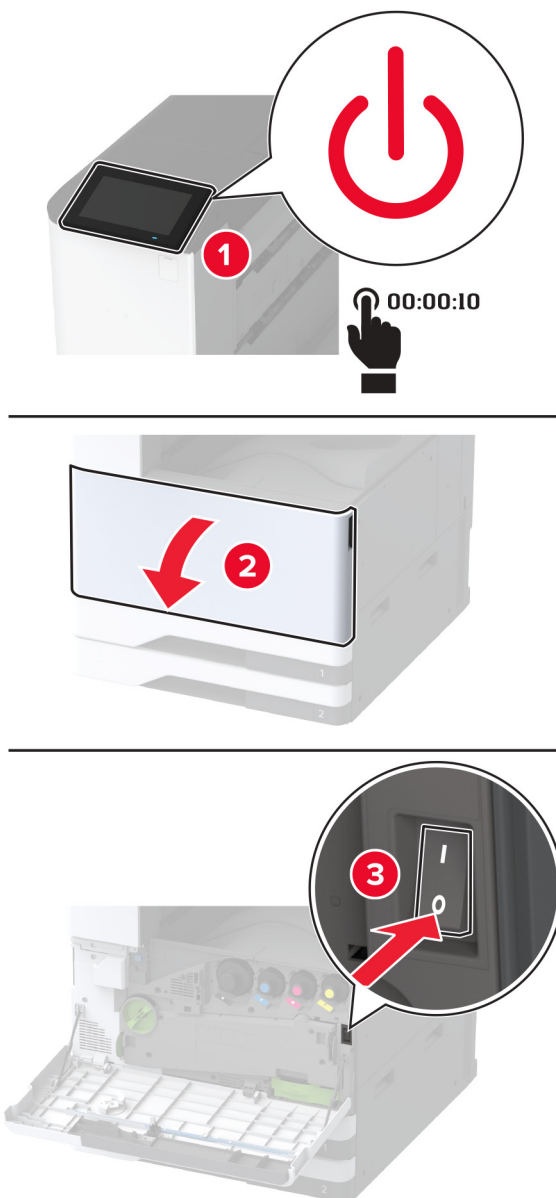

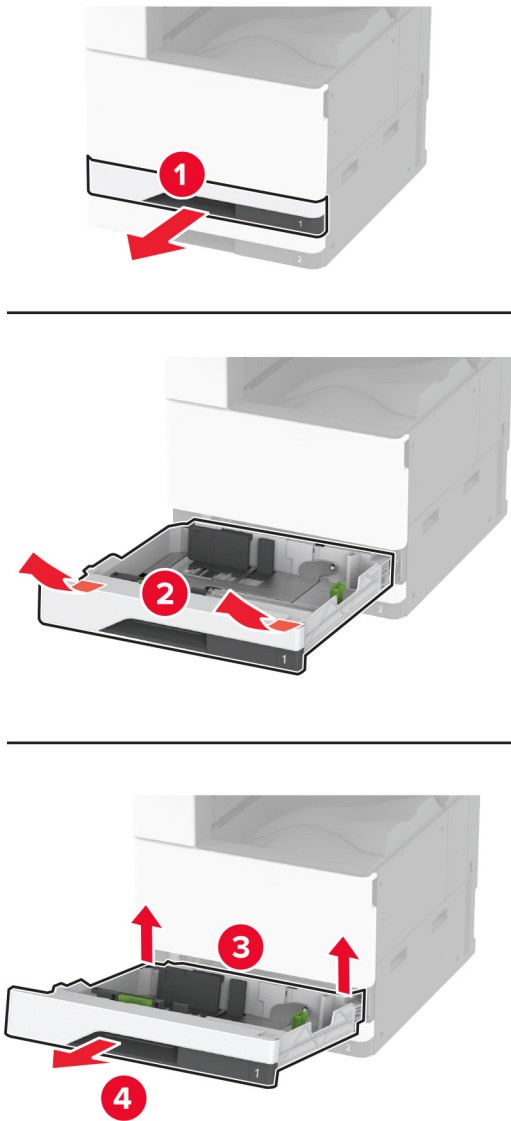
2 Remove the standard tray.**3** Remove the tray roller kit.

Warning—Potential Damage: To prevent damage from electrostatic discharge, touch any exposed metal frame of the printer before accessing or touching interior areas of the printer.

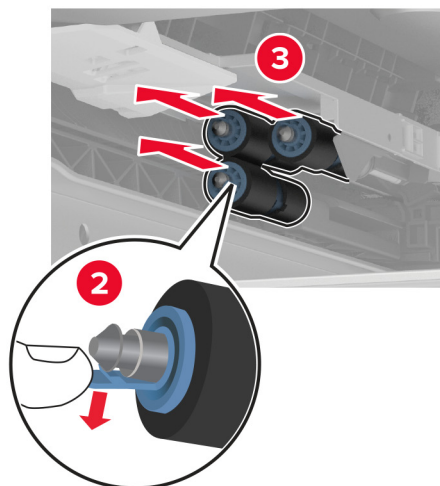
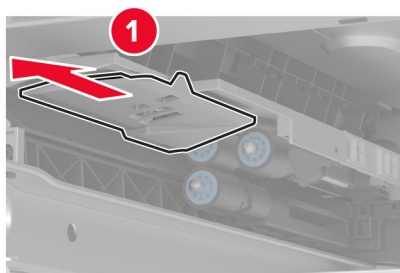
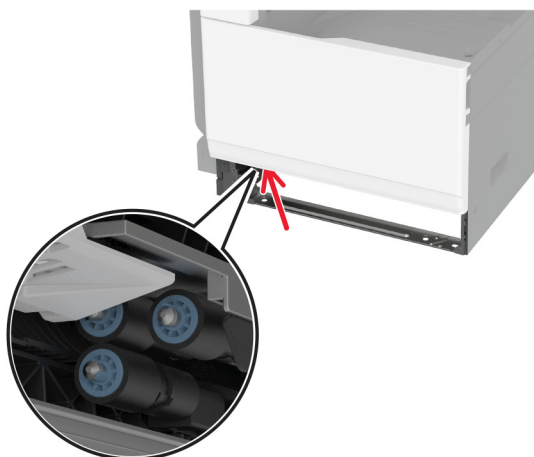

4 Apply water to a soft, lint-free cloth, and then wipe the feed rollers.

5 Insert the roller kit until it *clicks* into place.

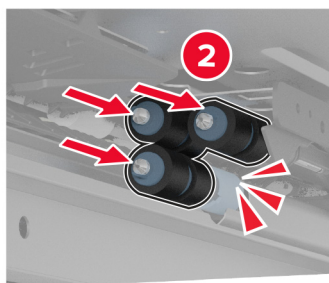
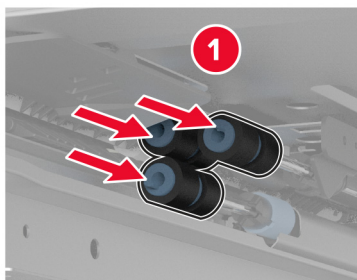

6 Insert the tray.

7 Turn on the printer.

Cleaning the 2000-sheet tray roller kit

- 1 Turn off the printer.

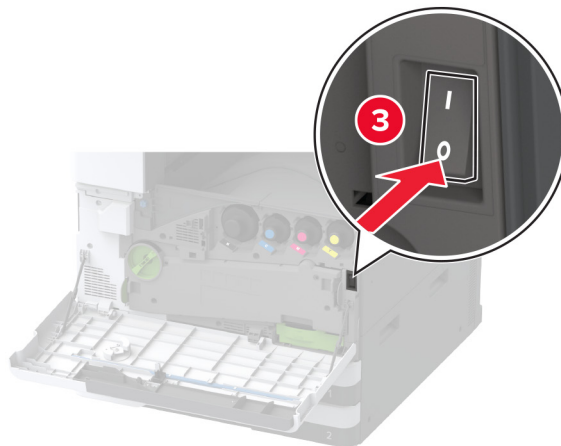
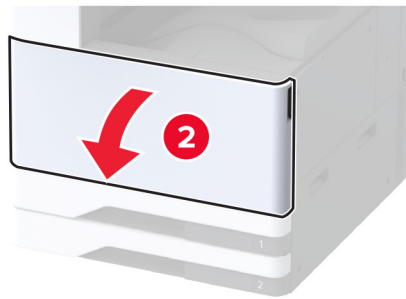
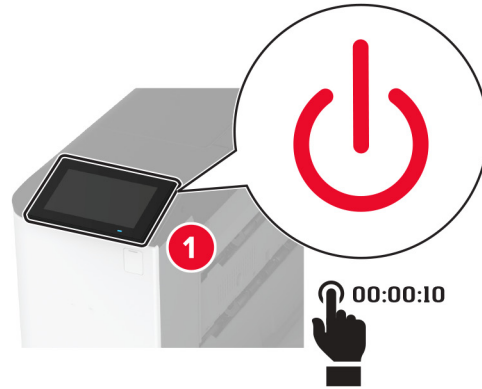

2 Slide the tray to the left.

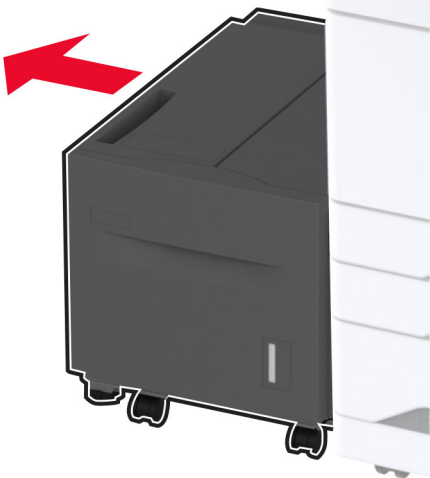

3 Open door J, and then open the roller kit cover.

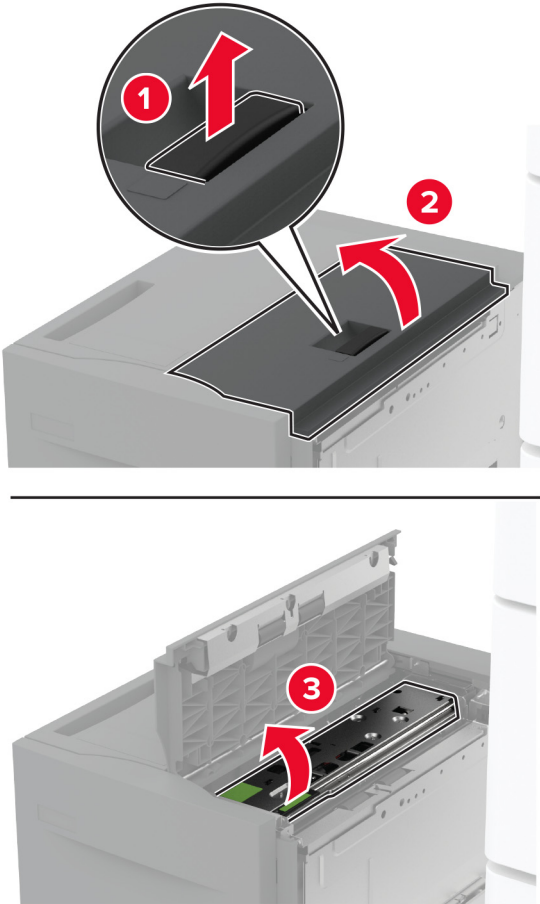

4 Locate, and then remove the tray roller kit.

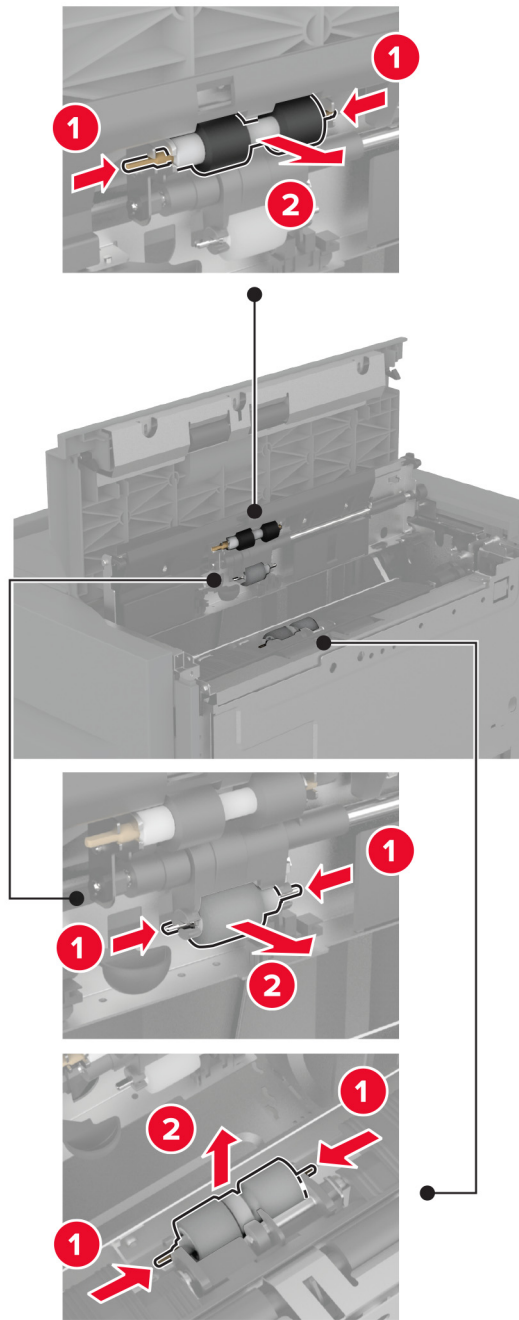

5 Apply water to a soft, lint-free cloth, and then wipe the roller kit.

6 Insert the roller kit.

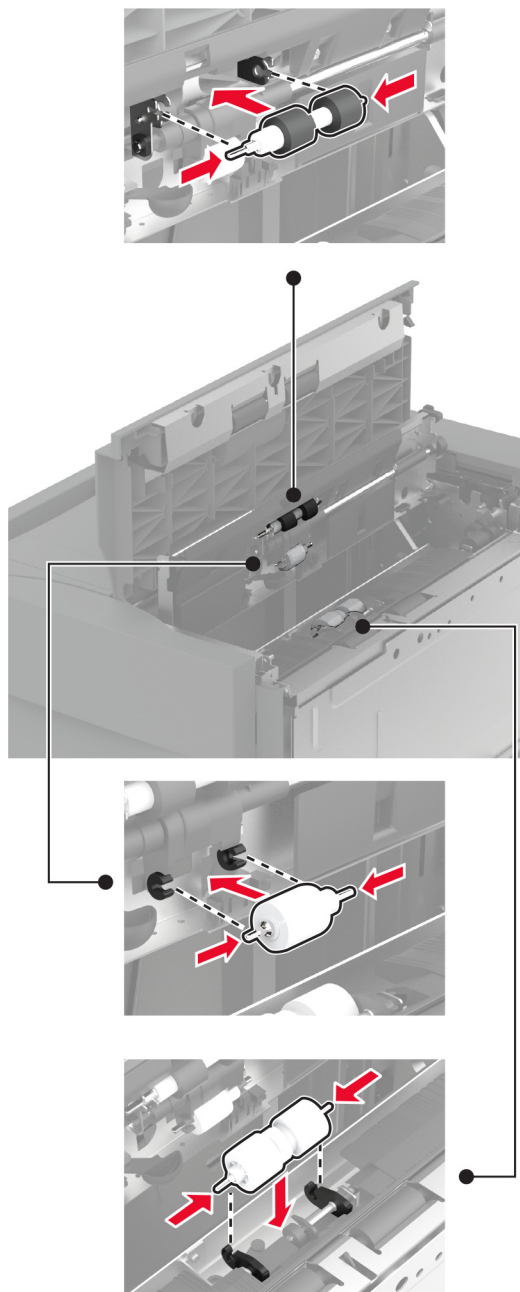

7 Close the roller kit cover, and then close door J.

8 Slide the tray back into place.

9 Turn on the printer.

Cleaning the 2000-sheet tandem tray roller kit

In handle C

- 1 Turn off the printer.

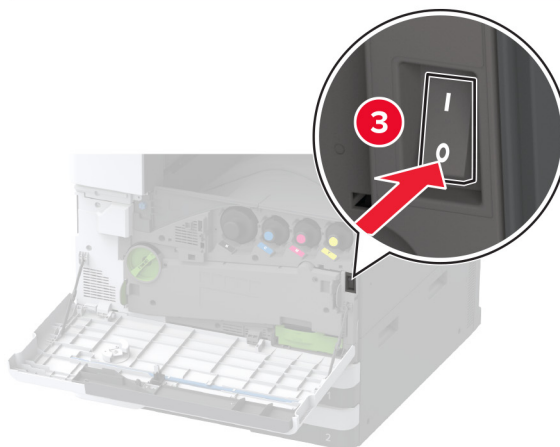
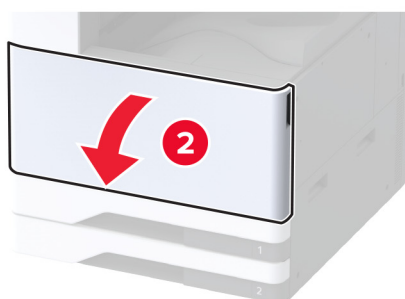
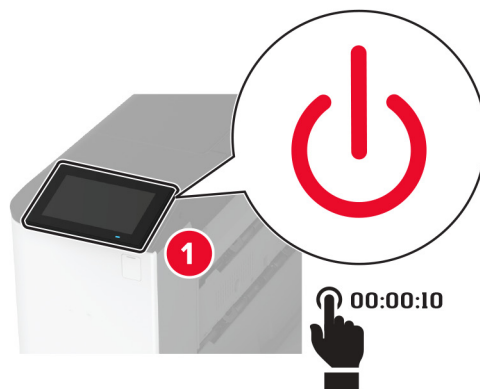

2 Pull out tray 4, and then pull out tray 3.

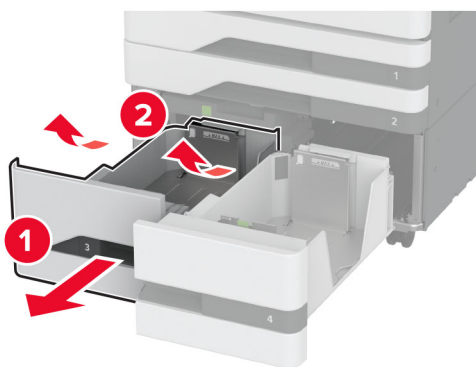
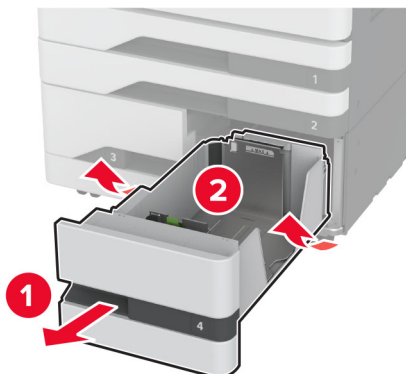

3 Pull out handle C, and then open the inner cover.

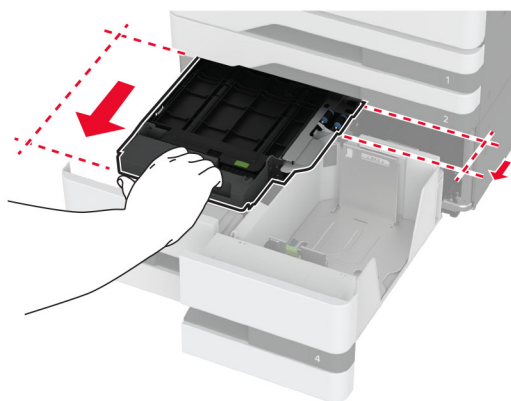

- 4 Open the roller kit cover.



- 5 Remove the tray roller kit.

Warning—Potential Damage: To prevent damage from electrostatic discharge, touch any exposed metal frame of the printer before accessing or touching interior areas of the printer.

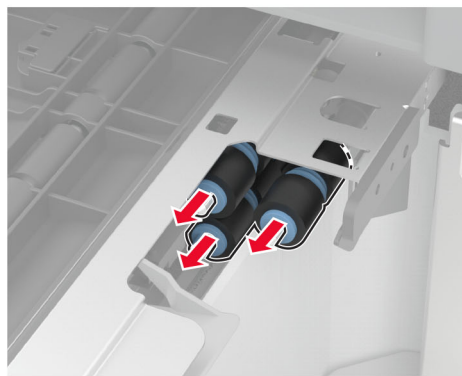
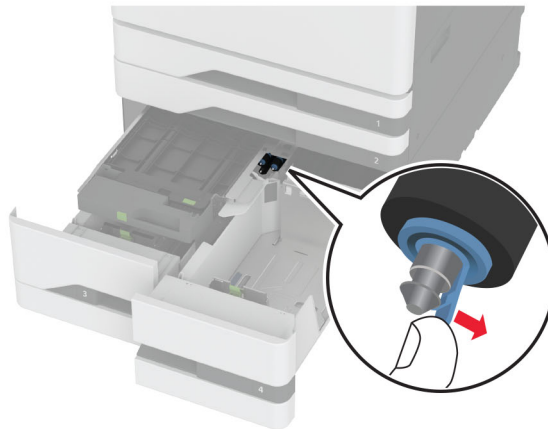

- 6 Apply water to a soft, lint-free cloth, and then wipe the pick rollers.
- 7 Insert the roller kit until it *clicks* into place.
- 8 Close the roller kit cover.

9 Close the inner cover, and then insert handle C.

10 Insert trays 3 and 4.

11 Turn on the printer.

In tray 3

1 Turn off the printer.

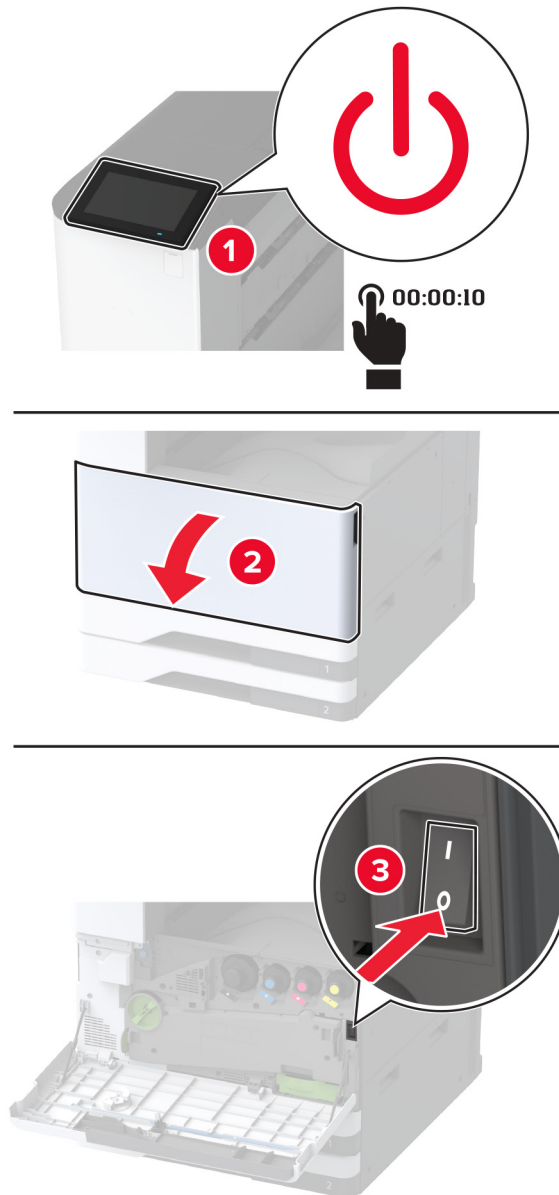

2 Remove tray 1, and then remove tray 2.

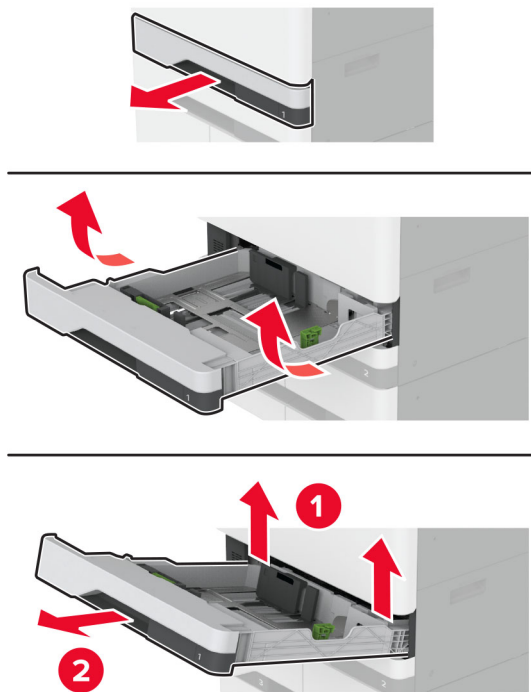

3 Pull out trays 3 and 4.

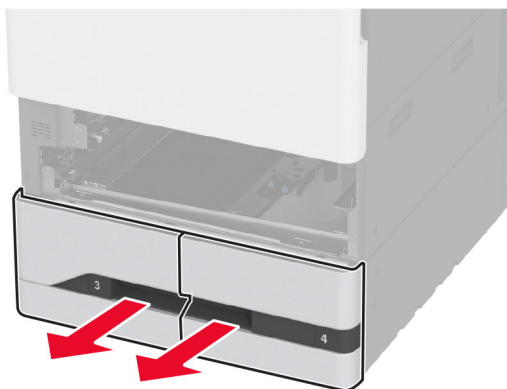

- 4 Pull out handle C.

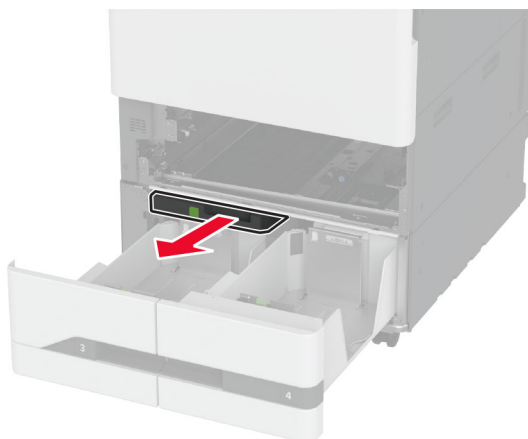

- 5 Remove the tray roller kit.

Warning—Potential Damage: To prevent damage from electrostatic discharge, touch any exposed metal frame of the printer before accessing or touching interior areas of the printer.

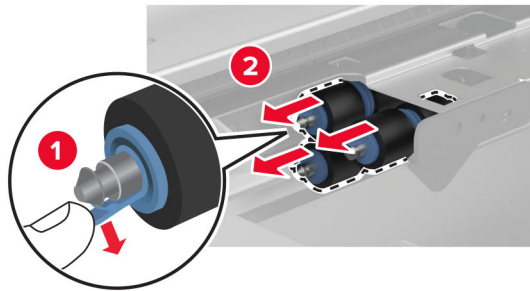
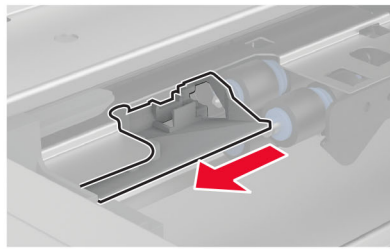
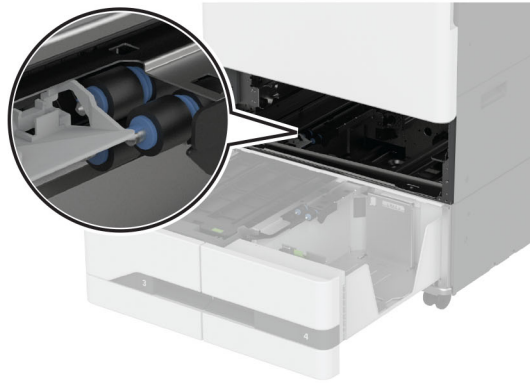

- 6** Apply water to a soft, lint-free cloth, and then wipe the pick rollers.
- 7** Insert the roller kit until it *clicks* into place.
- 8** Insert handle C.
- 9** Insert trays 3 and 4.
- 10** Insert trays 1 and 2.
- 11** Turn on the printer.

Emptying the hole punch box

- 1 Lift paper transport cover F.

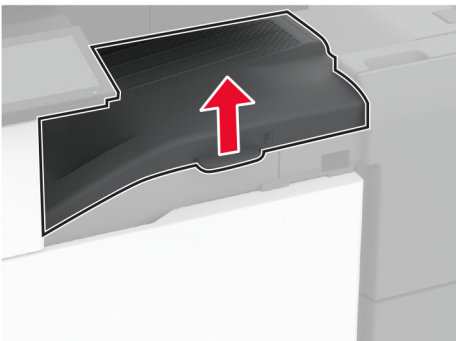

- 2 Remove, and then empty the hole punch box.

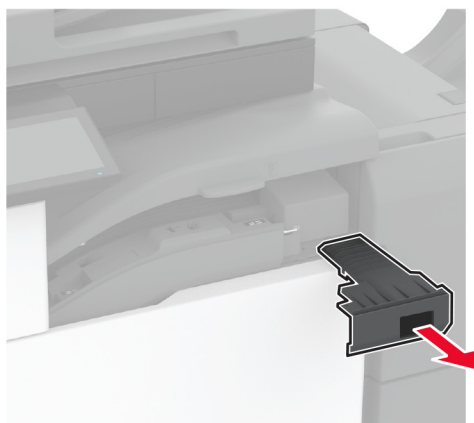

- 3 Insert the hole punch box.



- 4 Close paper transport cover F.
- 5 Open the booklet finisher door.

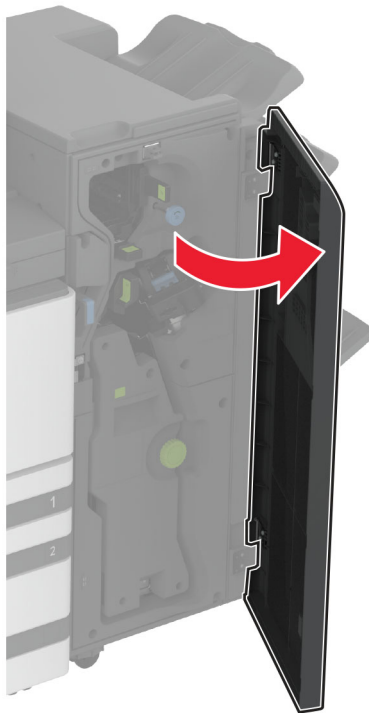

- 6 Remove, and then empty the hole punch box.

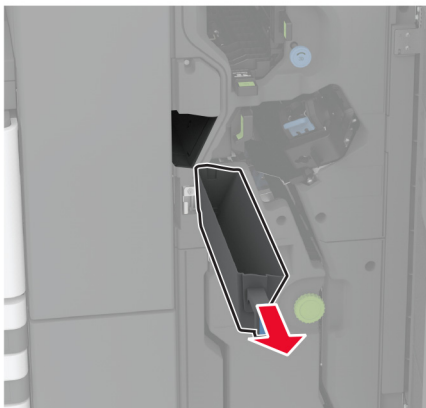

- 7 Insert the hole punch box.

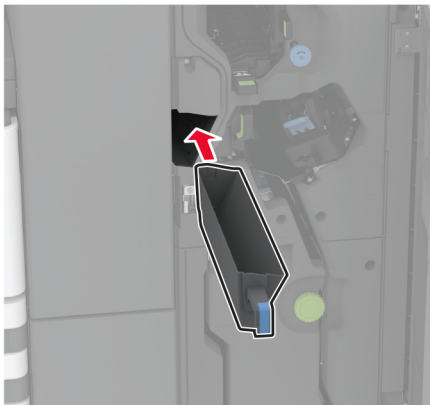

- 8 Close the finisher door.

Saving energy and paper

Configuring the power save mode settings

Sleep mode

- 1 From the home screen, touch **Settings** > **Device** > **Power Management** > **Timeouts** > **Sleep Mode**.
- 2 Specify the amount of time that the printer stays idle before it enters Sleep Mode.

Hibernate mode

- 1 From the home screen, touch **Settings** > **Device** > **Power Management** > **Timeouts** > **Hibernate Timeout**.
- 2 Select the amount of time that the printer stays idle before it enters Hibernate mode.

Notes:

- For Hibernate Timeout to work, set Hibernate Timeout on Connection to Hibernate.
- The Embedded Web Server is disabled when the printer is in Hibernate mode.

Adjusting the brightness of the display

- 1 From the home screen, touch **Settings** > **Device** > **Preferences**.
- 2 In the Screen Brightness menu, adjust the setting.

Conserving supplies

- Print on both sides of the paper.

Note: Two-sided printing is the default setting in the print driver.

- Print multiple pages on a single sheet of paper.
- Use the preview feature to see how the document looks like before printing it.
- Print one copy of the document to check its content and format for accuracy.

Moving the printer to another location

 **CAUTION—POTENTIAL INJURY:** If the printer weight is greater than 20 kg (44 lb), then it may require two or more people to lift it safely.

 **CAUTION—POTENTIAL INJURY:** To avoid the risk of fire or electrical shock, use only the power cord provided with this product or the manufacturer's authorized replacement.

 **CAUTION—POTENTIAL INJURY:** When moving the printer, follow these guidelines to avoid personal injury or printer damage:

- Make sure that all doors and trays are closed.
- Turn off the printer, and then unplug the power cord from the electrical outlet.
- Disconnect all cords and cables from the printer.
- If the printer has separate floor-standing optional trays or output options attached to it, then disconnect them before moving the printer.
- If the printer has a caster base, then carefully roll it to the new location. Use caution when passing over thresholds and breaks in flooring.
- If the printer does not have a caster base but is configured with optional trays or output options, then remove the output options and lift the printer off the trays. Do not try to lift the printer and any options at the same time.
- Always use the handholds on the printer to lift it.
- Any cart used to move the printer must have a surface able to support the full footprint of the printer.
- Any cart used to move the hardware options must have a surface able to support the dimensions of the options.
- Keep the printer in an upright position.
- Avoid severe jarring movements.
- Make sure that your fingers are not under the printer when you set it down.
- Make sure that there is adequate clearance around the printer.

Note: Damage to the printer caused by improper moving is not covered by the printer warranty.

Shipping the printer

For shipping instructions, go to <http://support.lexmark.com> or contact customer support.

Troubleshoot a problem

Print quality problems

Find the image that resembles the print quality problem you are having, and then click the link below it to read problem-solving steps.

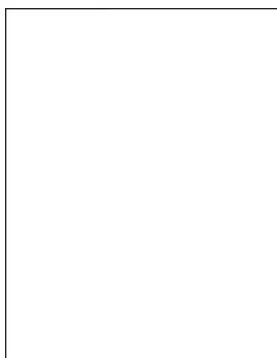

[“Blank or white pages” on page 331](#)

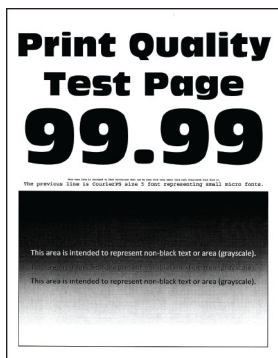

[“Dark print” on page 332](#)



[“Ghost images” on page 333](#)

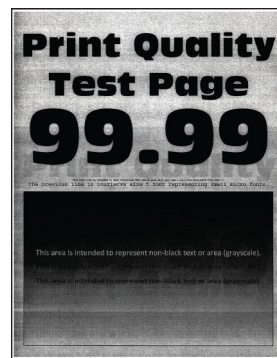

[“Gray or colored background” on page 334](#)



[“Incorrect margins” on page 335](#)

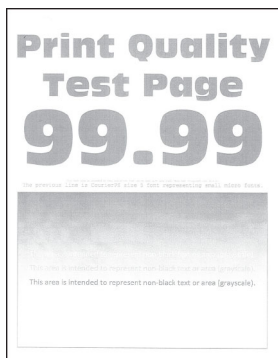

[“Light print” on page 336](#)

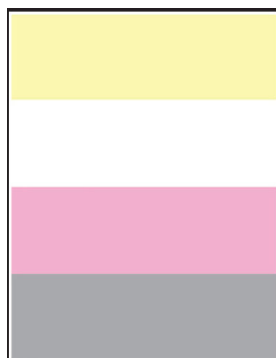

[“Missing colors” on page 338](#)

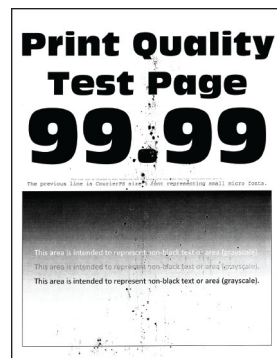

[“Mottled print and dots” on page 339](#)



[“Paper curl” on page 340](#)



[“Print crooked or skewed” on page 341](#)

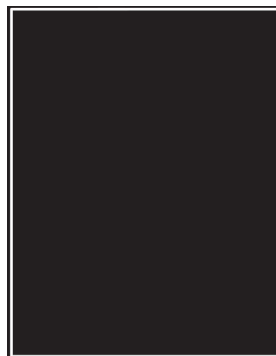

[“Solid color or black images” on page 342](#)

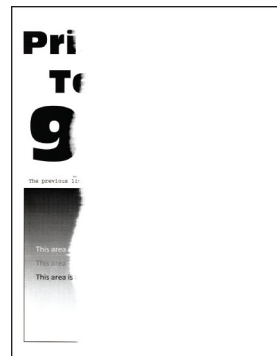

[“Text or images cut off” on page 343](#)

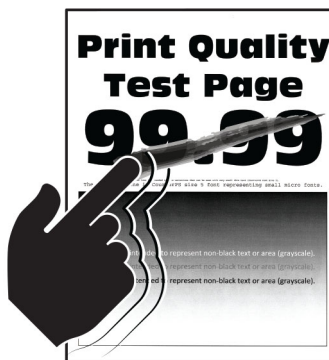

[“Toner easily rubs off” on page 344](#)

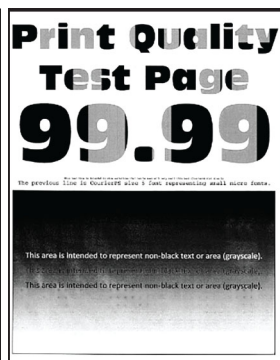

[“Uneven print density” on page 344](#)

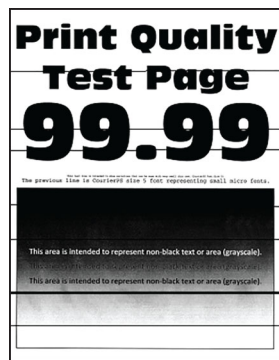

[“Horizontal dark lines” on page 345](#)



[“Vertical dark lines” on page 346](#)

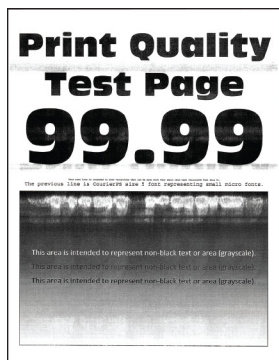

[“Horizontal white lines” on page 347](#)

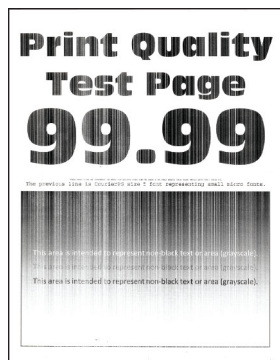

[“Vertical white lines” on page 349](#)



[“Repeating defects” on page 350](#)

Printer error codes

Error codes	Error message	Solution
2.01	Supply needed.	Touch Cancel Job and order the needed supply. For more information, see “Ordering parts and supplies” on page 223.
3.01	The standard output bin is full.	Remove paper from the bin, and then touch Continue.
3.21, 3.22, 3.23, 3.24	Remove paper behind tray [x].	<ol style="list-style-type: none"> 1 Remove the indicated tray. 2 Remove any jammed paper in the area. 3 Insert the tray.
7.13, 7.23, 7.33, 7.43, 7.53	Insert tray [x].	Try either of the following: <ul style="list-style-type: none"> • Insert the indicated tray. • Cancel the current print job.
8.01	Close the front door.	Keep the front door closed unless performing maintenance.
8.02, 8.03, 8.04, 8.05	Close door [x].	Keep the indicated door closed unless performing maintenance.

Error codes	Error message	Solution
8.06	Attach tray 5.	Slide the tray to the left, and then slide it back into place.
8.07	Close paper transport cover F.	Keep the paper transport cover F closed unless performing maintenance.
8.08	Close the staple finisher front door.	Keep the finisher front door closed unless performing maintenance.
8.09	Close staple, hole punch finisher top cover.	Keep the finisher top cover closed unless performing maintenance.
9.00	Printer had to restart. Last job may be incomplete.	Touch Continue to clear the message and continue printing.
11.11, 11.21, 11.31, 11.41, 11.51	Load [source] with [type] [size].	Load the indicated tray with paper. For more information, see “Loading paper and specialty media” on page 41.
11.12, 11.22, 11.32, 11.42, 11.52	Load [source] with [type] [size] [orientation].	
11.81, 11.91	Load multipurpose feeder with [type] [size].	Load the multipurpose feeder with paper. For more information, see “Loading the multipurpose feeder” on page 55.
11.82, 11.92	Load multipurpose feeder with [type] [size] [orientation].	
12.11, 12.21, 12.31, 12.41, 12.51	Change [source] to [type] [size].	Pull out the indicated tray, remove paper, and then load the correct paper type and size. For more information, see “Loading paper and specialty media” on page 41.
12.12, 12.22, 12.32, 12.42, 12.52	Change [source] to [type] [size] [orientation].	
12.91	Change multipurpose feeder to [type] [size].	Remove paper, and then load the correct paper type and size. For more information, see “Loading the multipurpose feeder” on page 55.
12.92	Change multipurpose feeder to [type] [size] [orientation].	
31.00	Insert hole punch box.	<ol style="list-style-type: none"> 1 Open the paper transport cover F. 2 Remove the hole punch box. 3 Insert the hole punch box.
31.35	Reinstall missing or unresponsive waste toner bottle.	<ol style="list-style-type: none"> 1 Open the front door. 2 Remove the waste toner bottle. <p>Note: To avoid spilling the toner, place the bottle in an upright position.</p> <ol style="list-style-type: none"> 3 Insert the waste toner bottle. 4 Close the front door.
31.40, 31.41, 31.42, 31.43	Reinstall missing or unresponsive [color] cartridge.	<ol style="list-style-type: none"> 1 Open the front door. 2 Remove the cartridge. 3 Insert the cartridge. 4 Close the front door.

Error codes	Error message	Solution
31.60, 31.61, 31.62, 31.63	Reinstall missing or unresponsive [color] photoconductor.	<ol style="list-style-type: none"> 1 Open the front door. 2 Unlock, and then remove the waste toner transfer unit. Note: To avoid spilling the toner, place the unit in an upright position. 3 Unlock, and then remove the photoconductor unit. 4 Insert the photoconductor unit, and then lock it in place. 5 Insert the waste toner transfer unit, and then lock it in place. 6 Close the front door.
32.40, 31.41, 31.42, 31.43	Replace unsupported [color] cartridge.	See “Replacing a toner cartridge” on page 224.
32.60, 32.61, 32.62, 32.63	Replace unsupported [color] photoconductor.	See “Replacing a photoconductor unit” on page 229.
34.00	Paper too short.	Set the paper size setting to match the paper loaded in the tray. From the home screen, touch Settings > Paper > Tray > Configuration > Paper Size/Type.
34.10, 34.20, 34.30, 34.40, 34.50	Check [source], adjust guides and orientation.	Pull out the indicated tray, and then make sure that the paper is loaded correctly. For more information, see “Loading paper and specialty media” on page 41.
34.90	Check multipurpose feeder, adjust guides and orientation.	Make sure that the paper is loaded correctly. For more information, see “Loading the multipurpose feeder” on page 55.
37.10	Insufficient memory to collate job.	Try either of the following: <ul style="list-style-type: none"> • Touch Continue to print the part of the job that is stored and to begin collating the rest of the print job. • Cancel the current print job.
37.30	Insufficient memory, some held jobs were deleted.	Touch Continue to clear the message and continue printing.
38.10	Memory full.	Try one or more of the following: <ul style="list-style-type: none"> • Touch Continue to clear the message and continue printing. • Cancel the current print job. • Install more printer memory. • Reduce the number of pages in the print job.

Error codes	Error message	Solution
39.10	Complex page, some data may not have printed.	Try one or more of the following: <ul style="list-style-type: none"> • Touch Continue to clear the message and continue printing. • Cancel the current print job. • Install more printer memory. • Reduce the complexity and size of the print job before sending it to print again. • Reduce the number of pages in the print job. • Reduce the number and size of any downloaded fonts. • Delete any unnecessary fonts or macros from the print job. • Reduce the number of graphics in the print job.
51	Defective flash detected.	Try one or more of the following: <ul style="list-style-type: none"> • Replace the flash memory. • Touch Continue to clear the message and continue printing. • Cancel the current print job.
52	Not enough free space in flash memory for resources.	Try one or more of the following: <ul style="list-style-type: none"> • Touch Continue to clear the message and continue printing. • Delete fonts, macros, and other data stored in the flash memory. • Install a storage drive. For more information, see “Installing a printer hard disk” on page 140 or “Installing the intelligent storage drive” on page 146. <p>Note: Downloaded fonts and macros that are not previously stored in the flash memory are deleted.</p>
55.1	Error reading USB drive. Remove USB	Remove the flash drive to continue.
55.2	Error reading USB hub. Remove hub.	Remove the USB hub to continue.
55.3	Unplug and change mode.	
61	Remove defective disk.	Replace the defective storage drive.

Error codes	Error message	Solution
62	Disk full.	Try one or more of the following: <ul style="list-style-type: none"> • Touch Continue to clear the message and continue printing. • Delete fonts, macros, and other data stored in the hard disk. • Install a hard disk. For more information, see “Installing a printer hard disk” on page 140. • Install an intelligent storage drive. For more information, see “Installing the intelligent storage drive” on page 146.
63	Format the disk.	Formatting now wipes all information from the storage drive. To format the storage drive, do the following: <ol style="list-style-type: none"> 1 From the home screen, touch Settings > Device > Maintenance > Out of Service Erase. 2 Touch Sanitize all information on hard disk, and then touch ERASE.
71.40	Printer's time is incorrect.	Configure the printer time. From the home screen, touch Settings > Device > Preferences > Date and Time > Configure.
80.21	Maintenance Kit near end of life	Touch Continue to clear the message.
80.31	Replace maintenance kit.	See “Replacing the tray roller kit” on page 250.
82.22	Waste toner bottle nearly full.	Touch Continue to clear the message.
82.42	Replace waste toner bottle.	See “Replacing the waste toner bottle” on page 271.
83.20	Staples low or missing.	Try either of the following:
83.30	Staples empty or misfed.	<ul style="list-style-type: none"> • Remove, and then insert the staple cartridge. • Replace the staple cartridge. For more information, see “Replacing the staple cartridge unit” on page 293.
84.01	[Color] photoconductor unit nearly low.	Touch Continue to clear the message.
84.11	[Color] photoconductor unit low.	
84.21	[Color] photoconductor unit very low.	

Error codes	Error message	Solution
84.31	Replace [color] photoconductor unit, recommended life exceeded.	See “Replacing a photoconductor unit” on page 229.
87.20	Hole punch box nearly full.	Touch Continue to clear the message.
87.30	Empty the hole punch box.	<ol style="list-style-type: none"> 1 Open the paper transport cover F. 2 Remove the hole punch box, and then empty it. 3 Insert the hole punch box. 4 Close the cover.
88.00[x]	[Color] cartridge nearly low.	Touch Continue to clear the message.
88.10[x]	[Color] cartridge low.	
88.20[x]	[Color] cartridge very low.	
88.30[x], 88.40[x]	Replace [color] cartridge.	See “Replacing a toner cartridge” on page 224.
200.03, 240.06	Paper jam [jam header].	See “Paper jam in the multipurpose feeder” on page 366.
200.16[x], 241.16a	Paper jam [jam header].	See “Paper jam in the standard tray” on page 361.
200.26[x], 200.36[x], 200.46[x], 200.56a, 202.95[x], 242.26, 242.33, 242.43, 243.33, 243.36, 243.43, 244.43, 244.46	Paper jam [jam header].	See “Paper jam in the optional trays” on page 362.
200.56a, 245.53[x], 245.56	Paper jam [jam header].	See “Paper jam in the 2000-sheet tray” on page 366.
200.95, 201.96, 202.93, 202.94, 221.93, 232.93, 240.25, 240.35, 240.55	Paper jam [jam header].	See “Paper jam in door A” on page 367.
400.13, 400.13b, 420.13b, 420.15b, 420.54c, 450.23b, 450.91b, 451.33b, 454.23b, 454.25b, 457.25b	Paper jam [jam header].	See “Paper jam in the staple, hole punch finisher” on page 373.
420.11a, 420.13a, 420.15a, 420.15b, 420.54a, 420.54b, 425.13a	Paper jam [jam header].	See “Paper jam in the staple finisher” on page 371.
420.15b, 450.33, 450.91a, 451.33a, 451.33b, 451.35, 454.33, 454.35, 454.36, 454.37, 457.35a, 457.35b, 490.33, 491.33, 491.35, 550.23, 551.23, 552.23, 553.23, 553.25, 555.23, 556.23	Paper jam [jam header].	See “Paper jam in the trifold/Z-fold finisher” on page 375.

Error codes	Error message	Solution
457.35b	Paper jam [jam header].	Try either of the following: <ul style="list-style-type: none"> • If you installed the staple finisher, see “Paper jam in the staple finisher” on page 371. • If you installed the staple, hole punch finisher, see “Paper jam in the staple, hole punch finisher” on page 373.

Printing problems

Print quality is poor

Blank or white pages

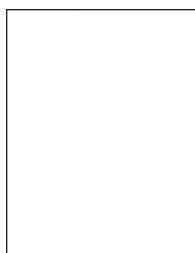

Note: Before solving the problem, print the Print Quality Test Pages. From the home screen, touch **Settings** > **Troubleshooting** > **Print Quality Test Pages**.

Action	Yes	No
<p>Step 1</p> <p>a Check if the printer is using a genuine and supported Lexmark toner cartridge.</p> <p>Note: If the cartridge is not supported, then install a supported one.</p> <p>b Print the document.</p> <p>Is the printer printing blank or white pages?</p>	Go to step 2.	The problem is solved.

Action	Yes	No
<p>Step 2</p> <p>a Remove the photoconductor units.</p> <p>Warning—Potential Damage: Do not expose the photoconductor units to direct light. Extended exposure to light may cause print quality problems.</p> <p>Warning—Potential Damage: Do not touch the photoconductor drums. Doing so may affect the quality of future print jobs.</p> <p>b Insert the photoconductor units.</p> <p>c Print the document.</p> <p>Is the printer printing blank or white pages?</p>	<p>Contact customer support.</p>	<p>The problem is solved.</p>

Dark print



Note: Before solving the problem, print the quality sample pages to determine the missing color. From the home screen, touch **Settings > Troubleshooting > Print Quality Test Pages**.

Action	Yes	No
<p>Step 1</p> <p>a Perform Color Adjust.</p> <p>From the home screen, touch Settings > Print > Quality > Advanced Imaging > Color Adjust.</p> <p>b Print the document.</p> <p>Is the print too dark?</p>	<p>Go to step 2.</p>	<p>The problem is solved.</p>
<p>Step 2</p> <p>a Depending on your operating system, reduce the toner darkness from the Printing Preferences or Print dialog.</p> <p>Note: You can also change the settings on the printer control panel. From the home screen, touch Settings > Print > Quality > Toner Darkness.</p> <p>b Print the document.</p> <p>Is the print too dark?</p>	<p>Go to step 3.</p>	<p>The problem is solved.</p>

Action	Yes	No
<p>Step 3</p> <p>a Depending on your operating system, specify the paper type from the Printing Preferences or Print dialog.</p> <p>Notes:</p> <ul style="list-style-type: none"> • Make sure that the settings match the paper loaded in the tray. • You can also change the settings on the printer control panel. From the home screen, touch Settings > Paper > Tray Configuration > Paper Size/Type. <p>b Print the document.</p> <p>Is the print too dark?</p>	Go to step 4.	Go to step 6.
<p>Step 4</p> <p>Make sure that the paper has no texture or rough finishes.</p> <p>Are you printing on textured or rough paper?</p>	Go to step 5.	Go to step 6.
<p>Step 5</p> <p>a Replace textured or rough paper with plain paper.</p> <p>b Print the document.</p> <p>Is the print too dark?</p>	Go to step 6.	The problem is solved.
<p>Step 6</p> <p>a Load paper from a fresh package.</p> <p>Note: Paper absorbs moisture due to high humidity. Store paper in its original wrapper until you are ready to use it.</p> <p>b Print the document.</p> <p>Is the print too dark?</p>	Contact customer support .	The problem is solved.

Ghost images

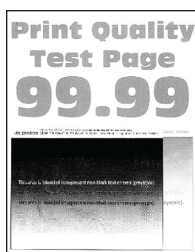

Note: Before solving the problem, print the Print Quality Test Pages. From the home screen, touch **Settings > Troubleshooting > Print Quality Test Pages**.

Action	Yes	No
<p>Step 1</p> <p>a Load the tray with the correct paper type and weight.</p> <p>b Print the document.</p> <p>Do ghost images appear on prints?</p>	Go to step 2.	The problem is solved.
<p>Step 2</p> <p>a Depending on your operating system, specify the paper type from the Printing Preferences or Print dialog.</p> <p>Notes:</p> <ul style="list-style-type: none"> • Make sure that the setting matches the paper loaded in the tray. • You can also change the setting on the printer control panel. From the home screen, touch Settings > Paper > Tray Configuration > Paper Size/Type. <p>b Print the document.</p> <p>Do ghost images appear on prints?</p>	Go to step 3.	The problem is solved.
<p>Step 3</p> <p>a Perform Color Adjust.</p> <p>From the home screen, touch Settings > Print > Quality > Advanced Imaging > Color Adjust.</p> <p>b Print the document.</p> <p>Do ghost images appear on prints?</p>	Contact customer support .	The problem is solved.

Gray or colored background



Note: Before solving the problem, print the Print Quality Test Pages. From the home screen, touch **Settings > Troubleshooting > Print Quality Test Pages**.

Action	Yes	No
<p>Step 1</p> <p>a Depending on your operating system, increase toner darkness from the Printing Preferences or Print dialog.</p> <p>Note: You can also change the setting on the printer control panel. From the home screen, touch Settings > Print > Quality > Toner Darkness.</p> <p>b Print the document.</p> <p>Does gray or colored background appear on prints?</p>	Go to step 2.	The problem is solved.
<p>Step 2</p> <p>a Perform Color Adjust.</p> <p>From the home screen, touch Settings > Print > Quality > Advanced Imaging > Color Adjust.</p> <p>b Print the document.</p> <p>Does gray or colored background appear on prints?</p>	Go to step 3.	The problem is solved.
<p>Step 3</p> <p>a Remove the photoconductor units.</p> <p>Warning—Potential Damage: Do not expose the photoconductor units to direct light. Extended exposure to light may cause print quality problems.</p> <p>Warning—Potential Damage: Do not touch the photoconductor drums. Doing so may affect the quality of future print jobs.</p> <p>b Insert the photoconductor units.</p> <p>c Print the document.</p> <p>Does gray or colored background appear on prints?</p>	Contact customer support .	The problem is solved.

Incorrect margins



Action	Yes	No
<p>Step 1</p> <p>a Adjust the paper guides in the tray to the correct position for the paper loaded.</p> <p>b Print the document.</p> <p>Are the margins correct?</p>	The problem is solved.	Go to step 2.
<p>Step 2</p> <p>a Depending on your operating system, specify the paper size from the Printing Preferences or Print dialog.</p> <p>Notes:</p> <ul style="list-style-type: none"> • Make sure that the setting matches the paper loaded. • You can also change the setting on the printer control panel. From the home screen, touch Settings > Paper > Tray Configuration > Paper Size/Type. <p>Note:</p> <p>b Print the document.</p> <p>Are the margins correct?</p>	The problem is solved.	Contact customer support .

Light print

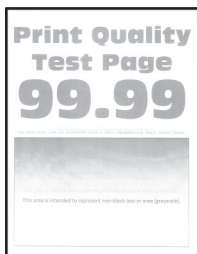

Note: Before solving the problem, print the Print Quality Test Pages. From the home screen, touch **Settings > Troubleshooting > Print Quality Test Pages**.

Action	Yes	No
<p>Step 1</p> <p>a Perform Color Adjust. From the home screen, touch Settings > Print > Quality > Advanced Imaging > Color Adjust.</p> <p>b Print the document.</p> <p>Is the print light?</p>	Go to step 2.	The problem is solved.

Action	Yes	No
<p>Step 2</p> <p>a Depending on your operating system, increase toner darkness from the Printing Preferences or Print dialog.</p> <p>Note: You can also change the setting on the printer control panel. From the home screen, touch Settings > Print > Quality > Toner Darkness.</p> <p>b Print the document.</p> <p>Is the print light?</p>	Go to step 3.	The problem is solved.
<p>Step 3</p> <p>a Turn off Color Saver.</p> <p>From the home screen, touch Settings > Print > Quality > Color Saver.</p> <p>b Print the document.</p> <p>Is the print light?</p>	Go to step 4.	The problem is solved.
<p>Step 4</p> <p>a Depending on your operating system, specify the paper type from the Printing Preferences or Print dialog.</p> <p>Notes:</p> <ul style="list-style-type: none"> • Make sure that the setting matches the paper loaded. • You can also change the setting on the printer control panel. From the home screen, touch Settings > Paper > Tray Configuration > Paper Size/Type. <p>b Print the document.</p> <p>Is the print light?</p>	Go to step 5.	The problem is solved.
<p>Step 5</p> <p>Check if paper has texture or rough finishes.</p> <p>Are you printing on textured or rough paper?</p>	Go to step 6.	Go to step 7.
<p>Step 6</p> <p>a Replace textured or rough paper with plain paper.</p> <p>b Print the document.</p> <p>Is the print light?</p>	Go to step 7.	The problem is solved.
<p>Step 7</p> <p>a Load paper from a fresh package.</p> <p>Note: Paper absorbs moisture due to high humidity. Store paper in its original wrapper until you are ready to use it.</p> <p>b Print the document.</p> <p>Is the print light?</p>	Go to step 8.	The problem is solved.

Action	Yes	No
<p>Step 8</p> <p>a Remove, and then insert the waste toner bottle.</p> <p>b Perform Color Adjust. From the home screen, touch Settings > Print > Quality > Advanced Imaging > Color Adjust.</p> <p>Is the print light?</p>	Go to step 9.	The problem is solved.
<p>Step 9</p> <p>a Remove the photoconductor units. Warning—Potential Damage: Do not expose the photoconductor units to direct light. Extended exposure to light may cause print quality problems. Warning—Potential Damage: Do not touch the photoconductor drums. Doing so may affect the quality of future print jobs.</p> <p>b Insert the photoconductor units.</p> <p>c Print the document.</p> <p>Is the print too light?</p>	Contact customer support .	The problem is solved.

Missing colors

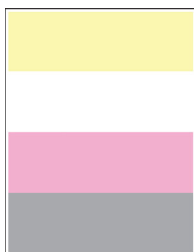

Note: Before solving the problem, print the Print Quality Test Pages. From the home screen, touch **Settings > Troubleshooting > Print Quality Test Pages.**

Action	Yes	No
<p>a Remove the photoconductor unit of the missing color.</p> <p>Warning—Potential Damage: Do not expose the photoconductor unit to direct light. Extended exposure to light may cause print quality problems.</p> <p>Warning—Potential Damage: Do not touch the photoconductor drum. Doing so may affect the quality of future print jobs.</p> <p>b Insert the photoconductor unit.</p> <p>c Remove the toner cartridge of the missing color.</p> <p>d Insert the toner cartridge of the missing color.</p> <p>e Print the document.</p> <p>Are some colors missing on print?</p>	<p>Contact customer support.</p>	<p>The problem is solved.</p>

Mottled print and dots



Note: Before solving the problem, print the Print Quality Test Pages. From the home screen, touch **Settings** > **Troubleshooting** > **Print Quality Test Pages**.

Action	Yes	No
<p>Step 1</p> <p>Check the printer for leaked toner contamination.</p> <p>Is the printer free of leaked toner?</p>	<p>Go to step 2.</p>	<p>Contact customer support.</p>
<p>Step 2</p> <p>a From the home screen, touch Settings > Paper > Tray Configuration > Paper Size/Type.</p> <p>b Check if the paper size and paper type settings match the paper loaded.</p> <p>Note: Make sure that the paper does not have texture or rough finishes.</p> <p>Do the settings match?</p>	<p>Go to step 4.</p>	<p>Go to step 3.</p>

Action	Yes	No
<p>Step 3</p> <p>a Depending on your operating system, specify the paper size and paper type from the Printing Preferences or Print dialog.</p> <p>Notes:</p> <ul style="list-style-type: none"> • Make sure that the settings match the paper loaded in the tray. • You can also change the settings on the printer control panel. From the home screen, touch Settings > Paper > Tray Configuration > Paper Size/Type. <p>b Print the document.</p> <p>Is the print mottled?</p>	Go to step 4.	The problem is solved.
<p>Step 4</p> <p>a Load paper from a fresh package.</p> <p>Note: Paper absorbs moisture due to high humidity. Store paper in its original wrapper until you are ready to use it.</p> <p>b Print the document.</p> <p>Is the print mottled?</p>	Go to step 5.	The problem is solved.
<p>Step 5</p> <p>a Remove the photoconductor units.</p> <p>Warning—Potential Damage: Do not expose the photoconductor units to direct light. Extended exposure to light may cause print quality problems.</p> <p>Warning—Potential Damage: Do not touch the photoconductor drums. Doing so may affect the quality of future print jobs.</p> <p>b Insert the photoconductor units.</p> <p>c Print the document.</p> <p>Is the print mottled?</p>	Contact customer support .	The problem is solved.

Paper curl



Action	Yes	No
<p>Step 1</p> <p>a Adjust the guides in the tray to the correct position for the paper loaded.</p> <p>b Print the document.</p> <p>Is the paper curled?</p>	Go to step 2.	The problem is solved.
<p>Step 2</p> <p>a Depending on your operating system, specify the paper type from the Printing Preferences or Print dialog.</p> <p>Notes:</p> <ul style="list-style-type: none"> • Make sure that the setting matches the paper loaded. • You can also change the setting on the printer control panel. From the home screen, touch Settings > Paper > Tray Configuration > Paper Size/Type. <p>b Print the document.</p> <p>Is the paper curled?</p>	Go to step 3.	The problem is solved.
<p>Step 3</p> <p>Print on the other side of the paper.</p> <p>a Remove paper, flip it over, and then reload paper.</p> <p>b Print the document.</p> <p>Is the paper curled?</p>	Go to step 4.	The problem is solved.
<p>Step 4</p> <p>a Load paper from a fresh package.</p> <p>Note: Paper absorbs moisture due to high humidity. Store paper in its original wrapper until you are ready to use it.</p> <p>b Print the document.</p> <p>Is the paper curled?</p>	Contact customer support .	The problem is solved.

Print crooked or skewed



Note: Before solving the problem, print the Print Quality Test Pages. From the home screen, touch **Settings** > **Troubleshooting** > **Print Quality Test Pages**.

Action	Yes	No
<p>Step 1</p> <p>a Pull out the tray.</p> <p>b Remove the paper, and then load paper from a fresh package.</p> <p>Note: Paper absorbs moisture due to high humidity. Store paper in its original wrapper until you are ready to use it.</p> <p>c Adjust the paper guides in the tray to the correct position for the paper loaded.</p> <p>d Insert the tray.</p> <p>e Print the document.</p> <p>Is the print crooked or skewed?</p>	Go to step 2.	The problem is solved.
<p>Step 2</p> <p>a Make sure that you are printing on a supported paper.</p> <p>b Print the document.</p> <p>Is the print crooked or skewed?</p>	Contact customer support .	The problem is solved.

Solid color or black images

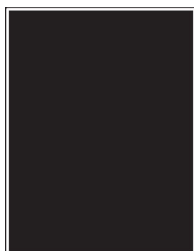

Note: Before solving the problem, print the Print Quality Test Pages. From the home screen, touch **Settings** > **Troubleshooting** > **Print Quality Test Pages**.

Action	Yes	No
<p>a Remove the photoconductor units.</p> <p>Warning—Potential Damage: Do not expose the photoconductor units to direct light. Extended exposure to light may cause print quality problems.</p> <p>Warning—Potential Damage: Do not touch the photoconductor drums. Doing so may affect the quality of future print jobs.</p> <p>b Insert the photoconductor units.</p> <p>c Print the document.</p> <p>Is the printer printing solid color or black images?</p>	Contact customer support .	The problem is solved.

Text or images cut off



Note: Before solving the problem, print the Print Quality Test Pages. From the home screen, touch **Settings** > **Troubleshooting** > **Print Quality Test Pages**.

Action	Yes	No
<p>Step 1</p> <p>a Adjust the paper guides in the tray to the correct position for the paper loaded.</p> <p>b Print the document.</p> <p>Is the text or image clipped?</p>	Go to step 2.	The problem is solved.
<p>Step 2</p> <p>a Depending on your operating system, specify the paper size from the Printing Preferences or Print dialog.</p> <p>Notes:</p> <ul style="list-style-type: none"> • Make sure that the setting matches the paper loaded in the tray. • You can also change the setting on the printer control panel. From the home screen, touch Settings > Paper > Tray Configuration > Paper Size/Type. <p>b Print the document.</p> <p>Is the text or image clipped?</p>	Go to step 3.	The problem is solved.
<p>Step 3</p> <p>a Remove the photoconductor units.</p> <p>Warning—Potential Damage: Do not expose the photoconductor units to direct light. Extended exposure to light may cause print quality problems.</p> <p>Warning—Potential Damage: Do not touch the photoconductor drums. Doing so may affect the quality of future print jobs.</p> <p>b Insert the photoconductor units.</p> <p>c Print the document.</p> <p>Is the text or image clipped?</p>	Contact customer support .	The problem is solved.

Toner easily rubs off



Note: Before solving the problem, print the Print Quality Test Pages. From the home screen, touch **Settings** > **Troubleshooting** > **Print Quality Test Pages**.

Action	Yes	No
<p>1 Depending on your operating system, specify the paper type from the Printing Preferences or Print dialog.</p> <p>Notes:</p> <ul style="list-style-type: none"> • Make sure that the setting matches the paper loaded. • You can also change the setting on the printer control panel. From the home screen, touch Settings > Paper > Tray Configuration > Paper Size/Type. <p>2 Print the document.</p> <p>Does the toner rub off?</p>	<p>Contact customer support.</p>	<p>The problem is solved.</p>

Uneven print density



Note: Before solving the problem, print the Print Quality Test Pages. From the home screen, touch **Settings** > **Troubleshooting** > **Print Quality Test Pages**.

Action	Yes	No
<p>Replace the photoconductor units, and then print the document.</p> <p>Is the print density uneven?</p>	<p>Contact customer support.</p>	<p>The problem is solved.</p>

Horizontal dark lines



Notes:

- Before solving the problem, print the Print Quality Test Pages. From the home screen, touch **Settings > Troubleshooting > Print Quality Test Pages**.
- If horizontal dark lines keep appearing on the prints, then see the “Repeating defects” topic.

Action	Yes	No
<p>Step 1</p> <p>a Depending on your operating system, specify the paper type from the Printing Preferences or Print dialog box.</p> <p>Notes:</p> <ul style="list-style-type: none"> • Make sure that the setting matches the paper loaded. • You can also change the setting on the printer control panel. From the home screen, touch Settings > Paper > Tray Configuration > Paper Size/Type. <p>b Print the document.</p> <p>Do horizontal dark lines appear on prints?</p>	Go to step 2.	The problem is solved.
<p>Step 2</p> <p>a Load paper from a fresh package.</p> <p>Note: Paper absorbs moisture due to high humidity. Store paper in its original wrapper until you use it.</p> <p>b Print the document.</p> <p>Do horizontal dark lines appear on prints?</p>	Go to step 3.	The problem is solved.
<p>Step 3</p> <p>a Remove the printhead wiper, and then clean the printhead lenses.</p> <p>b Print the document.</p> <p>Do horizontal dark lines appear on prints?</p>	Go to step 4.	The problem is solved.

Action	Yes	No
<p>Step 4</p> <p>a Remove the photoconductor units.</p> <p>Warning—Potential Damage: Do not expose the photoconductor units to direct light. Extended exposure to light may cause print quality problems.</p> <p>Warning—Potential Damage: Do not touch the photoconductor drums. Doing so may affect the quality of future print jobs.</p> <p>b Insert the photoconductor units.</p> <p>c Print the document.</p> <p>Do horizontal dark lines appear on prints?</p>	<p>Contact customer support.</p>	<p>The problem is solved.</p>

Vertical dark lines



Note: Before solving the problem, print the Print Quality Test Pages. From the home screen, touch **Settings > Troubleshooting > Print Quality Test Pages**.

Action	Yes	No
<p>Step 1</p> <p>a Depending on your operating system, specify the paper type from the Printing Preferences or Print dialog box.</p> <p>Notes:</p> <ul style="list-style-type: none"> • Make sure that the setting matches the paper loaded in the tray. • You can also change the setting on the printer control panel. From the home screen, touch Settings > Paper > Tray Configuration > Paper Size/Type. <p>b Print the document.</p> <p>Do vertical dark lines appear on prints?</p>	<p>Go to step 2.</p>	<p>The problem is solved.</p>

Action	Yes	No
<p>Step 2</p> <p>a Load paper from a fresh package.</p> <p>Note: Paper absorbs moisture due to high humidity. Store paper in its original wrapper until you use it.</p> <p>b Print the document.</p> <p>Do vertical dark lines appear on prints?</p>	Go to step 3.	The problem is solved.
<p>Step 3</p> <p>a Remove the printhead wiper, and then clean the printhead lenses.</p> <p>b Print the document.</p> <p>Do horizontal dark lines appear on prints?</p>	Go to step 4.	The problem is solved.
<p>Step 4</p> <p>a Remove the photoconductor units.</p> <p>Warning—Potential Damage: Do not expose the photoconductor units to direct light. Extended exposure to light may cause print quality problems.</p> <p>Warning—Potential Damage: Do not touch the photoconductor drums. Doing so may affect the quality of future print jobs.</p> <p>b Insert the photoconductor units.</p> <p>c Print the document.</p> <p>Do vertical dark lines appear on prints?</p>	Contact customer support .	The problem is solved.

Horizontal white lines

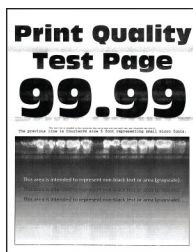

Notes:

- Before solving the problem, print the Print Quality Test Pages. From the home screen, touch **Settings > Troubleshooting > Print Quality Test Pages**.
- If horizontal white lines keep appearing on the prints, then see the “Repeating defects” topic.

Action	Yes	No
<p>Step 1</p> <p>a Depending on your operating system, specify the paper type from the Printing Preferences or Print dialog.</p> <p>Notes:</p> <ul style="list-style-type: none"> • Make sure that the setting matches the paper loaded in the tray. • You can also change the setting on the printer control panel. From the home screen, touch Settings > Paper > Tray Configuration > Paper Size/Type. <p>b Print the document.</p> <p>Do horizontal white lines appear on prints?</p>	Go to step 2.	The problem is solved.
<p>Step 2</p> <p>a Load the specified paper source with the recommended paper type.</p> <p>b Print the document.</p> <p>Do horizontal white lines appear on prints?</p>	Go to step 3.	The problem is solved.
<p>Step 3</p> <p>a Remove the printhead wiper, and then clean the printhead lenses.</p> <p>b Print the document.</p> <p>Do horizontal dark lines appear on prints?</p>	Go to step 4.	The problem is solved.
<p>Step 4</p> <p>a Remove the photoconductor units.</p> <p>Warning—Potential Damage: Do not expose the photoconductor units to direct light. Extended exposure to light may cause print quality problems.</p> <p>Warning—Potential Damage: Do not touch the photoconductor drums. Doing so may affect the quality of future print jobs.</p> <p>b Insert the photoconductor units.</p> <p>c Print the document.</p> <p>Do horizontal white lines appear on prints?</p>	Contact customer support .	The problem is solved.

Vertical white lines



Note: Before solving the problem, print the Print Quality Test Pages. From the home screen, touch **Settings** > **Troubleshooting** > **Print Quality Test Pages**.

Action	Yes	No
<p>Step 1</p> <p>a Depending on your operating system, specify the paper type from the Printing Preferences or Print dialog box.</p> <p>Notes:</p> <ul style="list-style-type: none"> • Make sure that the setting matches the paper loaded in the tray. • You can also change the setting on the printer control panel. From the home screen, touch Settings > Paper > Tray Configuration > Paper Size/Type. <p>b Print the document.</p> <p>Do vertical white lines appear on prints?</p>	Go to step 2.	The problem is solved.
<p>Step 2</p> <p>Check if you are using the recommended paper type.</p> <p>a Load the specified paper source with the recommended paper type.</p> <p>b Print the document.</p> <p>Do vertical white lines appear on prints?</p>	Go to step 3.	The problem is solved.
<p>Step 3</p> <p>a Remove the printhead wiper, and then clean the printhead lenses.</p> <p>b Print the document.</p> <p>Do horizontal dark lines appear on prints?</p>	Go to step 4.	The problem is solved.

Action	Yes	No
<p>Step 4</p> <p>a Remove the photoconductor units.</p> <p>Warning—Potential Damage: Do not expose the photoconductor units to direct light. Extended exposure to light may cause print quality problems.</p> <p>Warning—Potential Damage: Do not touch the photoconductor drums. Doing so may affect the quality of future print jobs.</p> <p>b Insert the photoconductor units.</p> <p>c Print the document.</p> <p>Do vertical white lines appear on prints?</p>	<p>Contact customer support.</p>	<p>The problem is solved.</p>

Repeating defects



Note: Before solving the problem, print the Print Quality Test Pages. From the home screen, touch **Settings > Troubleshooting > Print Quality Test Pages**.

Action	Yes	No
<p>Step 1</p> <p>a Using the Maintenance Defect Ruler page, measure the distance between the repeating defects on the affected color page.</p> <p>b Replace the supply item that matches the measurement on the affected color page.</p> <p>Photoconductor unit</p> <ul style="list-style-type: none"> • 94.6 mm (3.72 in.) • 37.7 mm (1.48 in.) <p>Developer unit</p> <ul style="list-style-type: none"> • 32.7 mm (1.29 in.) <p>c Print the Print Quality Test Pages.</p> <p>Do the defects still appear?</p>	<p>Take note of the distance, and then contact customer support or your service representative.</p>	<p>The problem is solved.</p>

Action	Yes	No
<p>Step 2</p> <p>a Using the Maintenance Defect Ruler page, measure the distance between the repeating defects on the affected color page.</p> <p>b Replace the supply item that matches the measurement on the affected color page.</p> <p>Second transfer roller 64.4 mm (2.54 in.)</p> <p>Fuser</p> <ul style="list-style-type: none"> • 96 mm (3.78 in.) • 88 mm (3.46 in.) <p>Transfer belt</p> <ul style="list-style-type: none"> • 37.7 mm (1.48 in.) • 31.4 mm (1.24 in.) • 70.7 mm (2.78 in.) • 46.9 mm (1.85 in.) <p>c Print the Print Quality Test Pages.</p> <p>Do the defects still appear?</p>	<p>Take note of the distance, and then contact customer support or your service representative.</p>	<p>The problem is solved.</p>

Print jobs do not print

Action	Yes	No
<p>Step 1</p> <p>a From the document you are trying to print, open the Print dialog, and then check if you have selected the correct printer.</p> <p>b Print the document.</p> <p>Is the document printed?</p>	<p>The problem is solved.</p>	<p>Go to step 2.</p>
<p>Step 2</p> <p>a Check if the printer is on.</p> <p>b Resolve any error messages that appear on the display.</p> <p>c Print the document.</p> <p>Is the document printed?</p>	<p>The problem is solved.</p>	<p>Go to step 3.</p>
<p>Step 3</p> <p>a Check if the ports are working and if the cables are securely connected to the computer and the printer. For more information, see the setup documentation that came with the printer.</p> <p>b Print the document.</p> <p>Is the document printed?</p>	<p>The problem is solved.</p>	<p>Go to step 4.</p>

Action	Yes	No
<p>Step 4</p> <p>a Turn off the printer, wait for about 10 seconds, and then turn on the printer.</p> <p>b Print the document.</p> <p>Is the document printed?</p>	The problem is solved.	Go to step 5.
<p>Step 5</p> <p>a Remove, and then reinstall the print driver.</p> <p>b Print the document.</p> <p>Is the document printed?</p>	The problem is solved.	Contact customer support .

Confidential and other held documents do not print

Action	Yes	No
<p>Step 1</p> <p>a From the control panel, check if the documents appear in the Held Jobs list.</p> <p>Note: If the documents are not listed, then print the documents using the Print and Hold options.</p> <p>b Print the documents.</p> <p>Are the documents printed?</p>	The problem is solved.	Go to step 2.
<p>Step 2</p> <p>The print job may contain a formatting error or invalid data.</p> <ul style="list-style-type: none"> • Delete the print job, and then send it again. • For PDF files, generate a new file, and then print the documents. <p>Are the documents printed?</p>	The problem is solved.	Go to step 3.

Action	Yes	No
<p>Step 3</p> <p>If you are printing from the Internet, then the printer may be reading the multiple job titles as duplicates.</p> <p>For Windows users</p> <ul style="list-style-type: none"> a Open the Printing Preferences dialog. b From the Print and Hold tab, click Use Print and Hold, and then click Keep duplicate documents. c Enter a PIN, and then save the changes. d Send the print job. <p>For Macintosh users</p> <ul style="list-style-type: none"> a Save and name each job differently. b Send the job individually. <p>Are the documents printed?</p>	<p>The problem is solved.</p>	<p>Go to step 4.</p>
<p>Step 4</p> <ul style="list-style-type: none"> a Delete some held jobs to free up printer memory. b Print the documents. <p>Are the documents printed?</p>	<p>The problem is solved.</p>	<p>Go to step 5.</p>
<p>Step 5</p> <ul style="list-style-type: none"> a Add printer memory. b Print the documents. <p>Are the documents printed?</p>	<p>The problem is solved.</p>	<p>Contact customer support.</p>

Job prints from the wrong tray or on the wrong paper

Action	Yes	No
<p>Step 1</p> <ul style="list-style-type: none"> a Check if you are printing on the correct paper. b Print the document. <p>Is the document printed on the correct paper?</p>	<p>Go to step 2.</p>	<p>Load the correct paper size and paper type.</p>

Action	Yes	No
<p>Step 2</p> <p>a Depending on your operating system, specify the paper size and paper type from the Printing Preferences or Print dialog.</p> <p>Note: You can also change the settings on the printer control panel. From the home screen, touch Settings > Paper > Tray Configuration > Paper Size/Type.</p> <p>b Make sure that the settings match the paper loaded.</p> <p>c Print the document.</p> <p>Is the document printed on the correct paper?</p>	<p>The problem is solved.</p>	<p>Go to step 3.</p>
<p>Step 3</p> <p>a Check if the trays are linked.</p> <p>For more information, see “Linking trays” on page 58.</p> <p>b Print the document.</p> <p>Is the document printed from the correct tray?</p>	<p>The problem is solved.</p>	<p>Contact customer support.</p>

Slow printing

Action	Yes	No
<p>Step 1</p> <p>Make sure that the printer cable is securely connected to the printer and to the computer, print server, option, or other network device.</p> <p>Is the printer printing slow?</p>	<p>Go to step 2.</p>	<p>The problem is solved.</p>
<p>Step 2</p> <p>a Make sure that the printer is not in Quiet Mode.</p> <p>From the home screen, touch Settings > Device > Maintenance > Config Menu > Device Operations > Quiet Mode.</p> <p>b Print the document.</p> <p>Is the printer printing slow?</p>	<p>Go to step 3.</p>	<p>The problem is solved.</p>
<p>Step 3</p> <p>a Depending on your operating system, specify the print resolution from the Printing Preferences or Print dialog.</p> <p>b Set the resolution to 2400 Image Q.</p> <p>c Print the document.</p> <p>Is the printer printing slow?</p>	<p>Go to step 4.</p>	<p>The problem is solved.</p>

Action	Yes	No
<p>Step 4</p> <p>a Depending on your operating system, specify the paper type from the Printing Preferences or Print dialog.</p> <p>Notes:</p> <ul style="list-style-type: none"> • Make sure that the setting matches the paper loaded. • You can also change the setting on the printer control panel. From the home screen, touch Settings > Paper > Tray Configuration > Paper Size/Type. • Heavier paper prints more slowly. • Paper narrower than letter, A4, and legal may print more slowly. <p>b Print the document.</p> <p>Is the printer printing slow?</p>	<p>Go to step 5.</p>	<p>The problem is solved.</p>
<p>Step 5</p> <p>a Make sure that the printer settings for texture and weight match the paper being loaded.</p> <p>From the home screen, touch Settings > Paper > Media Configuration > Media Types.</p> <p>Note: Rough paper texture and heavy paper weight may print more slowly.</p> <p>b Print the document.</p> <p>Is the printer printing slow?</p>	<p>Go to step 6.</p>	<p>The problem is solved.</p>
<p>Step 6</p> <p>Remove held jobs.</p> <p>Is the printer printing slow?</p>	<p>Go to step 7.</p>	<p>The problem is solved.</p>
<p>Step 7</p> <p>a Make sure that the printer is not overheating.</p> <p>Notes:</p> <ul style="list-style-type: none"> • Allow the printer to cool down after a long print job. • Observe the recommended ambient temperature for the printer. For more information, see “Selecting a location for the printer” on page 33. <p>b Print the document.</p> <p>Is the printer printing slow?</p>	<p>Contact customer support.</p>	<p>The problem is solved.</p>

The printer is not responding

Action	Yes	No
<p>Step 1 Check if the power cord is connected to the electrical outlet.</p> <p> CAUTION—POTENTIAL INJURY: To avoid the risk of fire or electrical shock, connect the power cord to an appropriately rated and properly grounded electrical outlet that is near the product and easily accessible.</p> <p>Is the printer responding?</p>	The problem is solved.	Go to step 2.
<p>Step 2 Check if the electrical outlet is turned off by a switch or breaker.</p> <p>Is the electrical outlet turned off by a switch or breaker?</p>	Turn on the switch or reset the breaker.	Go to step 3.
<p>Step 3 Check if the printer is on.</p> <p>Is the printer on?</p>	Go to step 4.	Turn on the printer.
<p>Step 4 Check if the printer is in Sleep or Hibernate mode.</p> <p>Is the printer in Sleep or Hibernate mode?</p>	Press the power button to wake the printer.	Go to step 5.
<p>Step 5 Check if the cables connecting the printer and the computer are inserted to the correct ports.</p> <p>Are the cables inserted to the correct ports?</p>	Go to step 6.	Insert the cables to the correct ports.
<p>Step 6 Turn off the printer, install the hardware options, and then turn on the printer. For more information, see the documentation that came with the option.</p> <p>Is the printer responding?</p>	The problem is solved.	Go to step 7.
<p>Step 7 Install the correct print driver.</p> <p>Is the printer responding?</p>	The problem is solved.	Go to step 8.
<p>Step 8 Turn off the printer, wait for about 10 seconds, and then turn on the printer.</p> <p>Is the printer responding?</p>	The problem is solved.	Contact customer support .

Unable to read flash drive

Action	Yes	No
<p>Step 1 Check if the printer is not busy processing another print, copy, scan, or fax job.</p> <p>Is the printer ready?</p>	Go to step 3.	Go to step 2.
<p>Step 2</p> <ul style="list-style-type: none"> • Wait for the printer to finish processing the other job. • Remove, and then insert the flash drive. <p>Does the printer recognize the flash drive?</p>	The problem is solved.	Go to step 3.
<p>Step 3 Check if the flash drive is inserted into the front USB port.</p> <p>Note: The flash drive does not work when it is inserted into the rear USB port.</p> <p>Is the flash drive inserted into the correct port?</p>	Go to step 5.	Go to step 4.
<p>Step 4 Insert the flash drive into the correct port.</p> <p>Does the printer recognize the flash drive?</p>	The problem is solved.	Go to step 5.
<p>Step 5 Check if the flash drive is supported. For more information, see “Supported flash drives and file types” on page 170.</p> <p>Is the flash drive supported?</p>	Go to step 7.	Go to step 6.
<p>Step 6 Insert a supported flash drive.</p> <p>Does the printer recognize the flash drive?</p>	The problem is solved.	Go to step 7.
<p>Step 7 Remove, and then insert the flash drive.</p> <p>Does the printer recognize the flash drive?</p>	The problem is solved.	Contact customer support .

Enabling the USB port

From the home screen, touch **Settings > Network/Ports > USB > Enable USB Port**.

Clearing jams

Avoiding jams

Load paper properly

- Make sure that the paper lies flat in the tray.

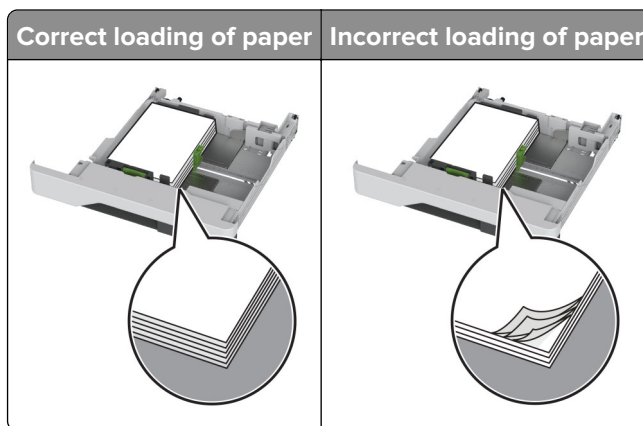

- Do not load or remove a tray while the printer is printing.
- Do not load too much paper. Make sure that the stack height is below the maximum paper fill indicator.
- Do not slide paper into the tray. Load paper as shown in the illustration.

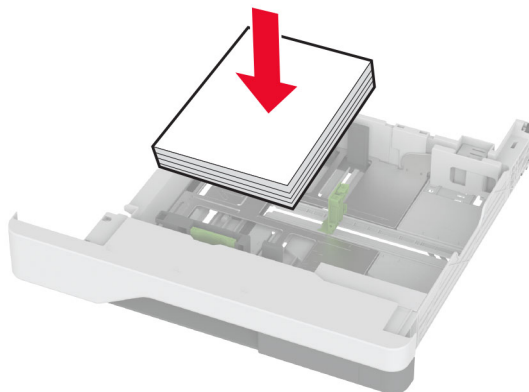

- Make sure that the paper guides are positioned correctly and are not pressing tightly against the paper or envelopes.
- Push the tray firmly into the printer after loading paper.

Use recommended paper

- Use only recommended paper or specialty media.
- Do not load paper that is wrinkled, creased, damp, bent, or curled.

- Flex, fan, and align the paper edges before loading.

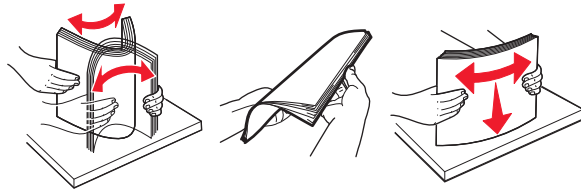

- Do not use paper that has been cut or trimmed by hand.
- Do not mix paper sizes, weights, or types in the same tray.
- Make sure that the paper size and type are set correctly on the computer or printer control panel.
- Store paper according to manufacturer recommendations.

Identifying jam locations

Notes:

- When Jam Assist is set to On, the printer flushes blank pages or pages with partial prints after a jammed page has been cleared. Check your printed output for blank pages.
- When Jam Recovery is set to On or Auto, the printer reprints jammed pages.



	Jam locations
1	Multipurpose feeder
2	Door A
3	Standard bin
4	Standard trays
5	Staple finisher
6	Paper transport
7	Staple, hole punch finisher
8	Trifold/Z-fold finisher
9	Booklet finisher

	Jam locations
10	Optional trays
11	2000-sheet tray

Paper jam in the standard tray

1 Open door A.

 **CAUTION—HOT SURFACE:** The inside of the printer might be hot. To reduce the risk of injury from a hot component, allow the surface to cool before touching it.

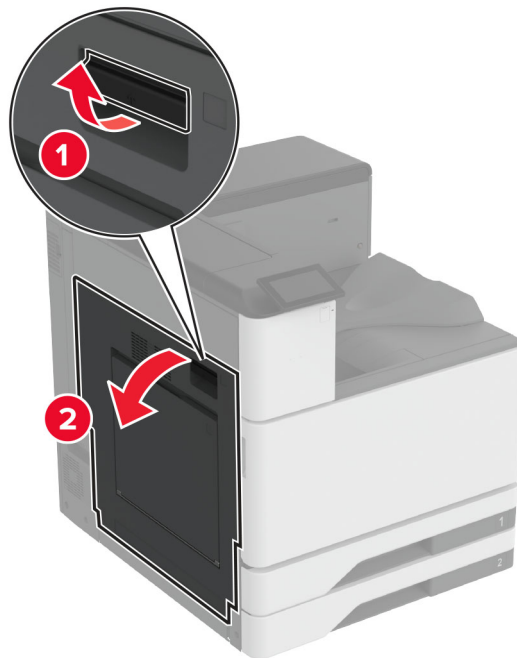

2 Remove the jammed paper.

Note: Make sure that all paper fragments are removed.

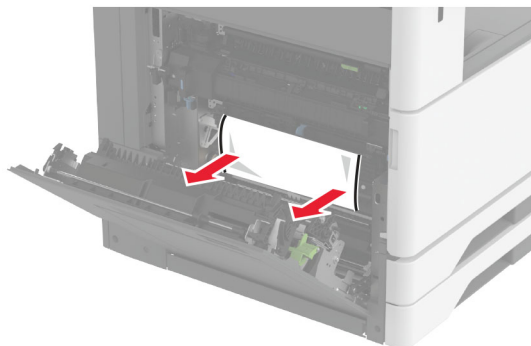

- 3 Pull out the standard tray.

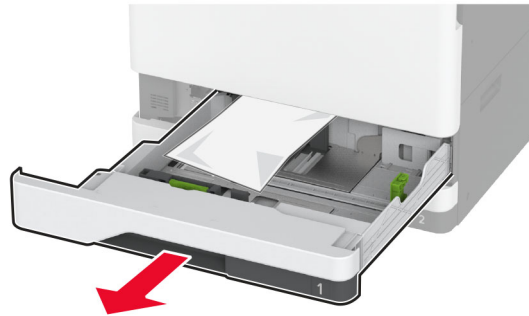

- 4 Remove the jammed paper.

Note: Make sure that all paper fragments are removed.

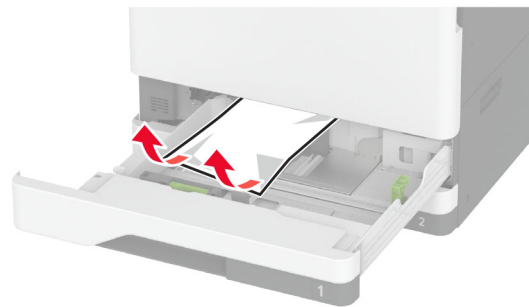

- 5 Insert the tray, and then close door A.

Paper jam in the optional trays

- 1 Open door B.

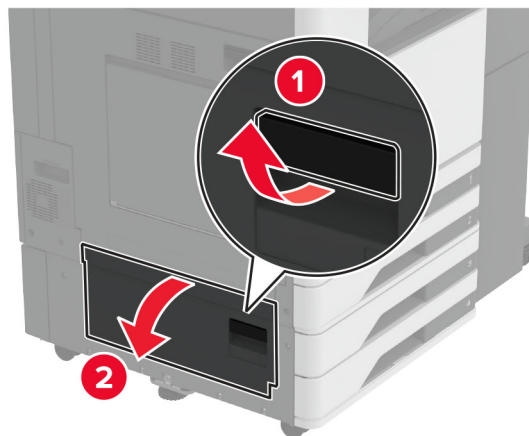

- 2 Remove the jammed paper.

Note: Make sure that all paper fragments are removed.

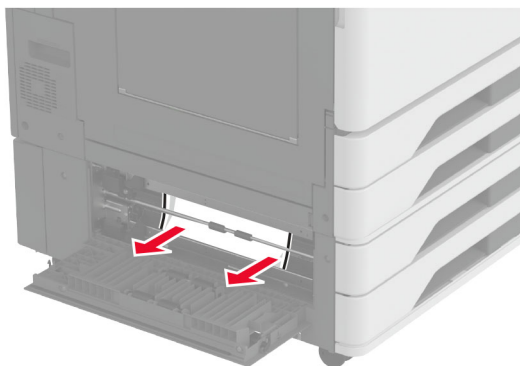

3 Close the door.

4 Pull out the optional 520-sheet tray or 2000-sheet tandem tray.



5 Remove the jammed paper.

Note: Make sure that all paper fragments are removed.

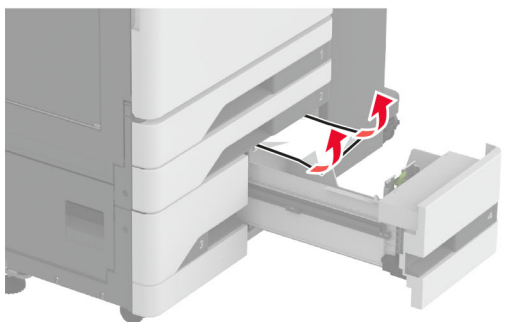
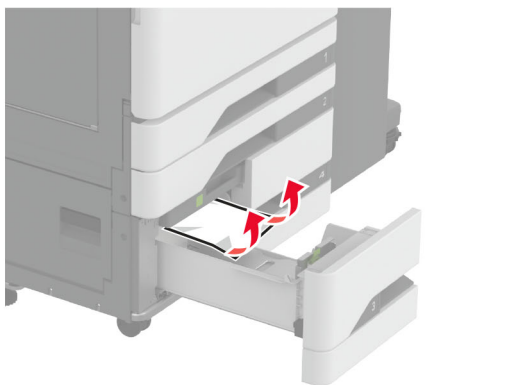
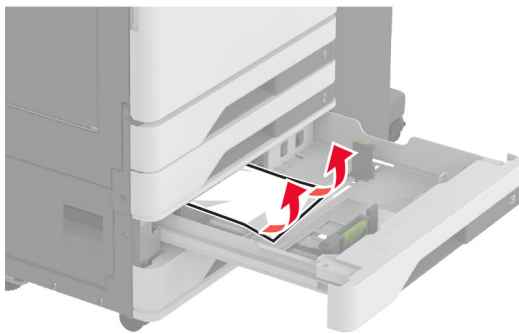

6 In tandem trays, pull out handle C, and then open the inner cover.

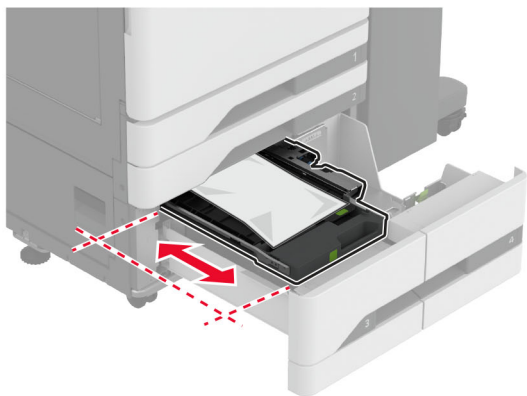
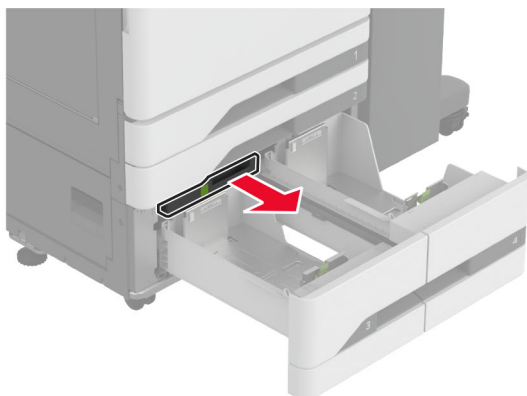

7 Remove the jammed paper.

Note: Make sure that all paper fragments are removed.

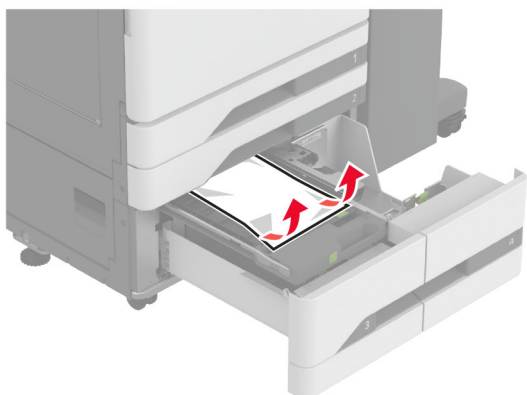

8 Close the cover, and then insert handle C.

9 Insert the tray.

Paper jam in the multipurpose feeder

Remove the jammed paper.

Note: Make sure that all paper fragments are removed.

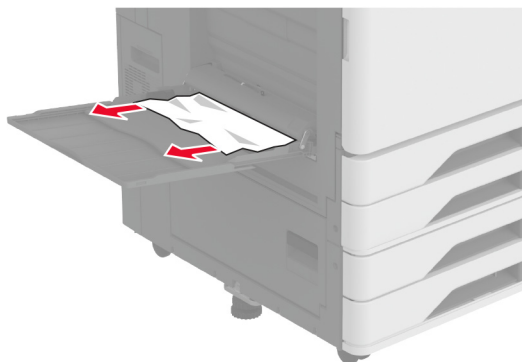

Paper jam in the 2000-sheet tray

1 Slide the tray to the left.

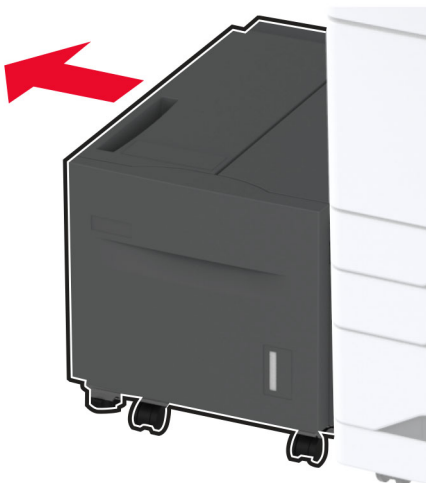

2 Open door J, and then remove the jammed paper.

Note: Make sure that all paper fragments are removed.

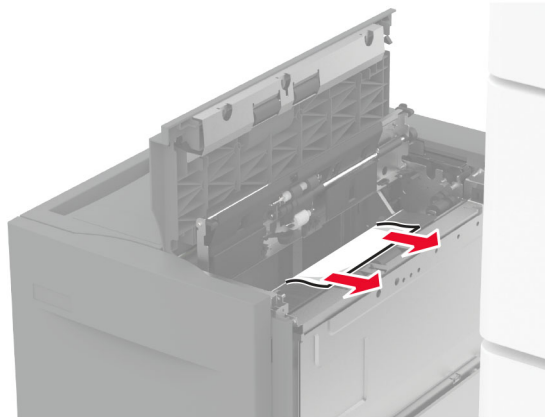

- 3 Close the door, and then slide the tray back into place.
- 4 Pull out the tray insert, and then remove the jammed paper.
Note: Make sure that all paper fragments are removed.

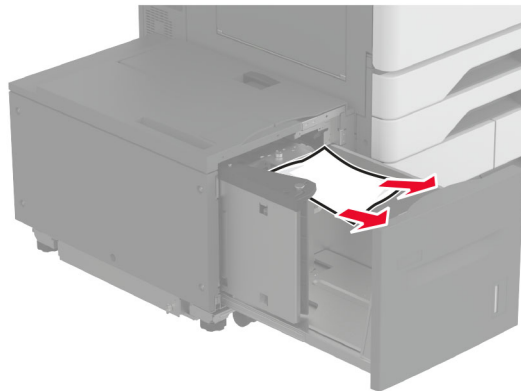

- 5 Push the tray insert back into place.

Paper jam in door A

- 1 Open door A.

 **CAUTION—HOT SURFACE:** The inside of the printer might be hot. To reduce the risk of injury from a hot component, allow the surface to cool before touching it.

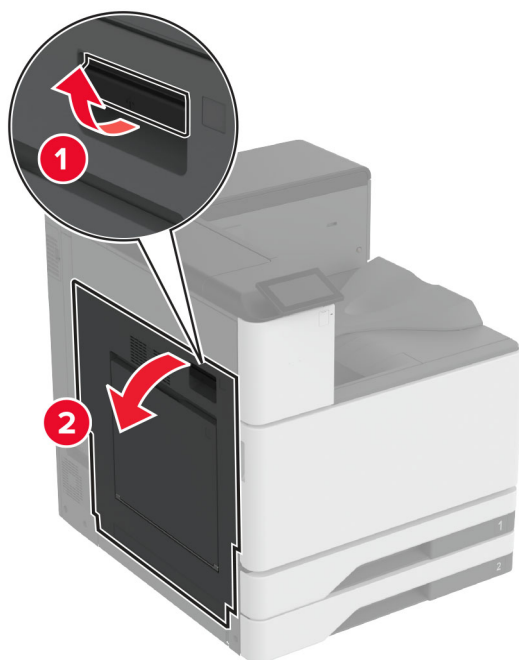

2 Remove the jammed paper.

Note: Make sure that all paper fragments are removed.

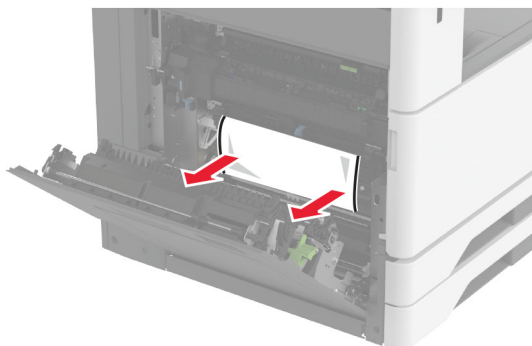

3 Open door A2, and then remove the jammed paper.

Note: Make sure that all paper fragments are removed.

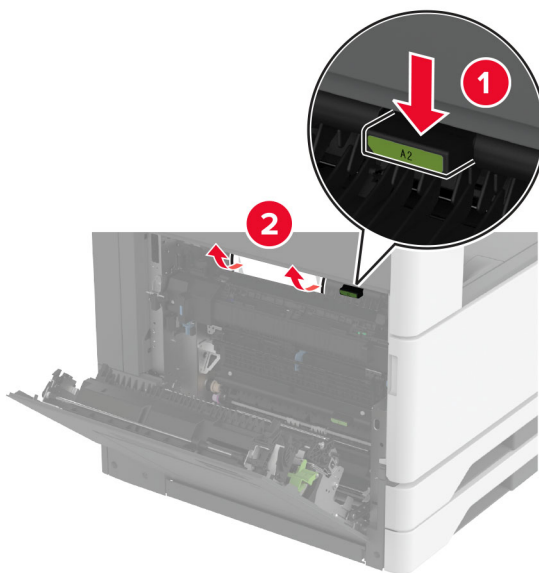

4 Lift door A3.

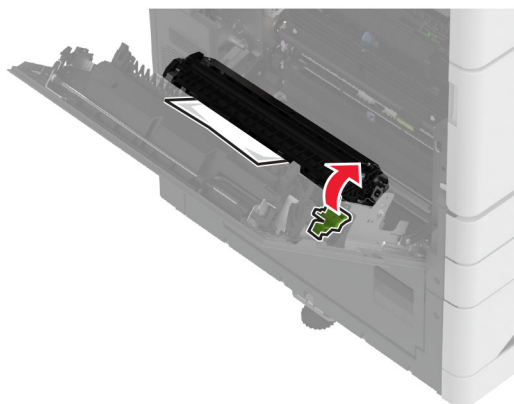

5 Remove the jammed paper.

Note: Make sure that all paper fragments are removed.

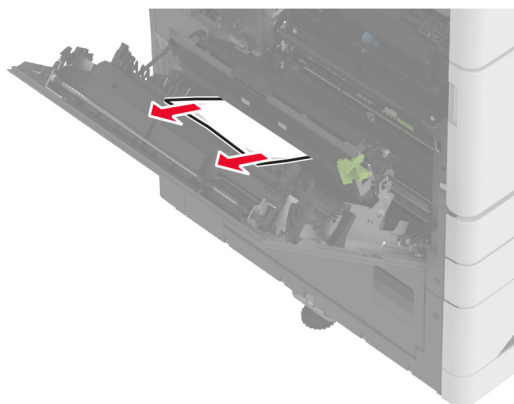

6 Close door A2, and then close door A.

Paper jam in the standard bin

- 1 Open door A.

 **CAUTION—HOT SURFACE:** The inside of the printer might be hot. To reduce the risk of injury from a hot component, allow the surface to cool before touching it.

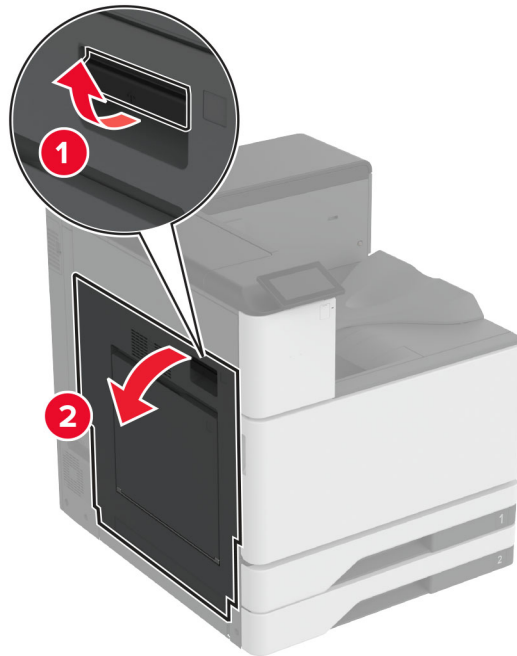

- 2 Open door A2, and then remove the jammed paper.

Note: Make sure that all paper fragments are removed.

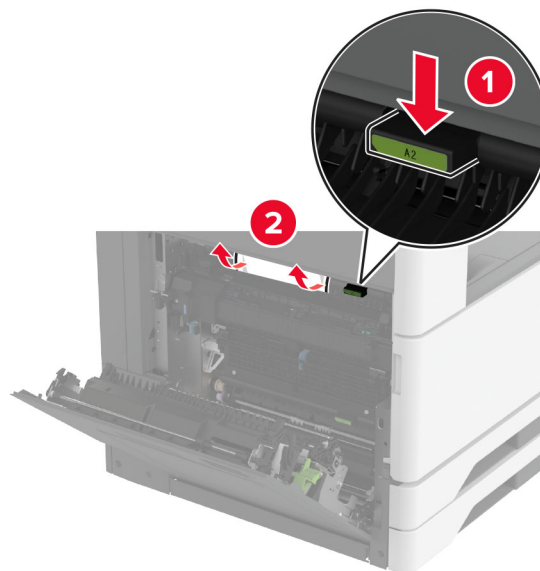

- 3 Close door A2, and then close door A.
- 4 Remove the jammed paper from the standard bin.

Note: Make sure that all paper fragments are removed.

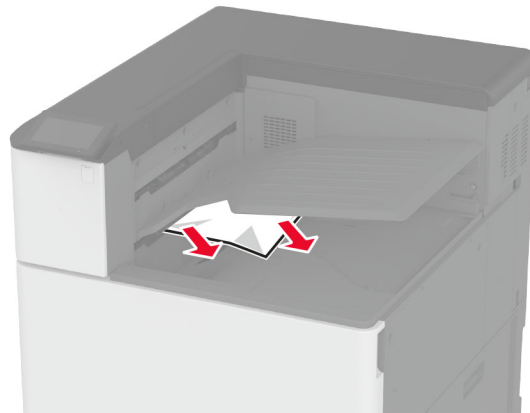

Paper jam in the staple finisher

1 Open door A.

 **CAUTION—HOT SURFACE:** The inside of the printer might be hot. To reduce the risk of injury from a hot component, allow the surface to cool before touching it.

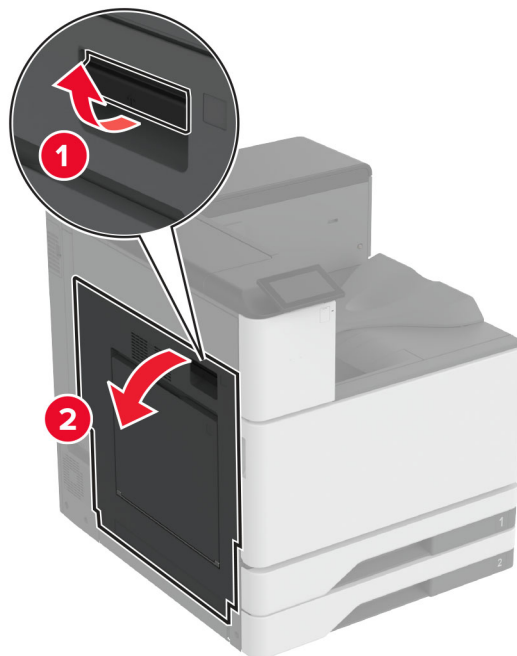

2 Open door A2, and then remove the jammed paper.

Note: Make sure that all paper fragments are removed.

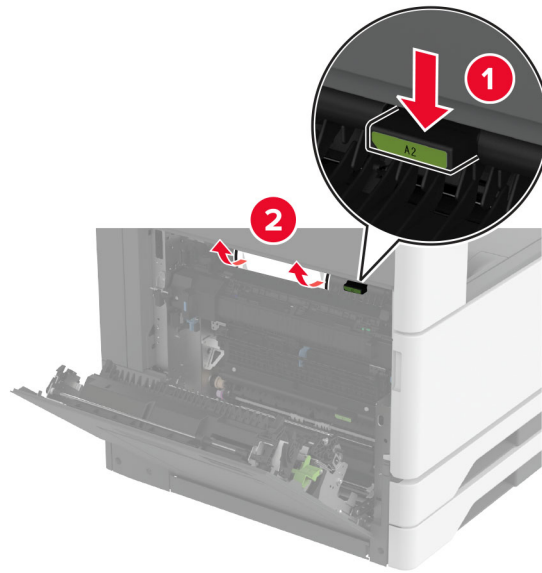

- 3 Close door A2, and then close door A.
- 4 Open the finisher top cover, and then remove the jammed paper.
Note: Make sure that all paper fragments are removed.

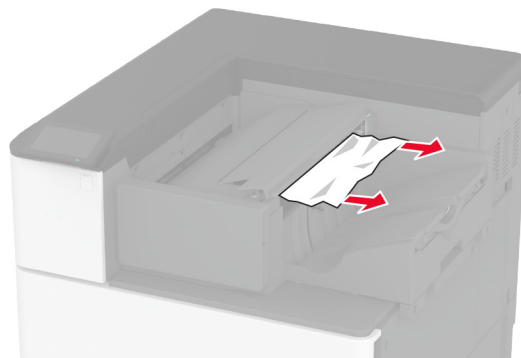
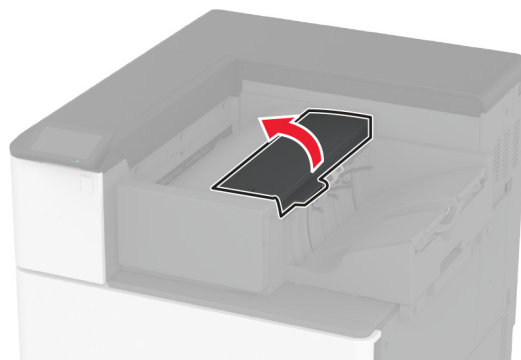

- 5 Close the cover.
- 6 Open the finisher front cover, turn the finisher knob, and then remove the jammed paper.
Note: Make sure that all paper fragments are removed.

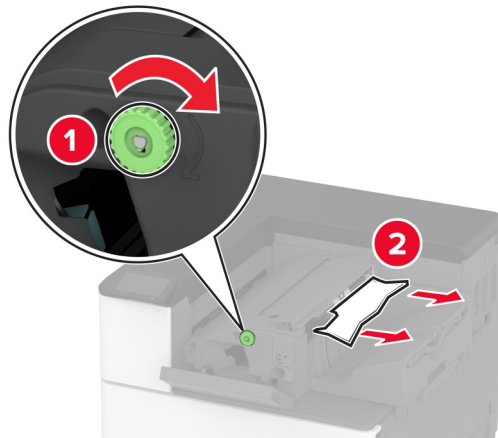

7 Close the cover.

Paper jam in the staple, hole punch finisher

1 Open door A.

 **CAUTION—HOT SURFACE:** The inside of the printer might be hot. To reduce the risk of injury from a hot component, allow the surface to cool before touching it.

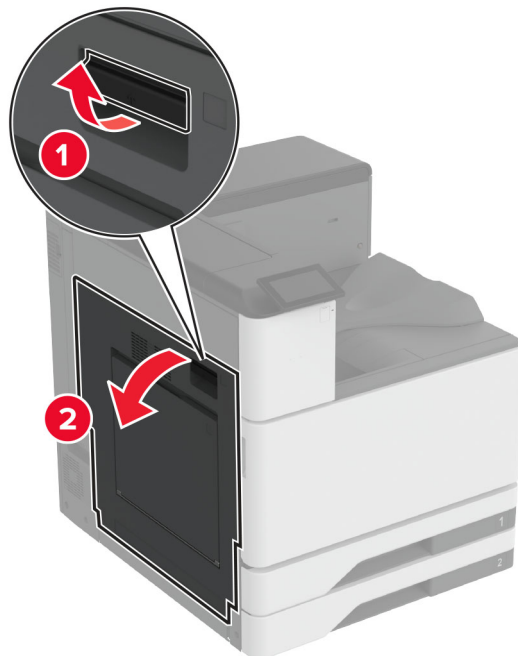

2 Open door A1, and then remove the jammed paper.

Note: Make sure that all paper fragments are removed.

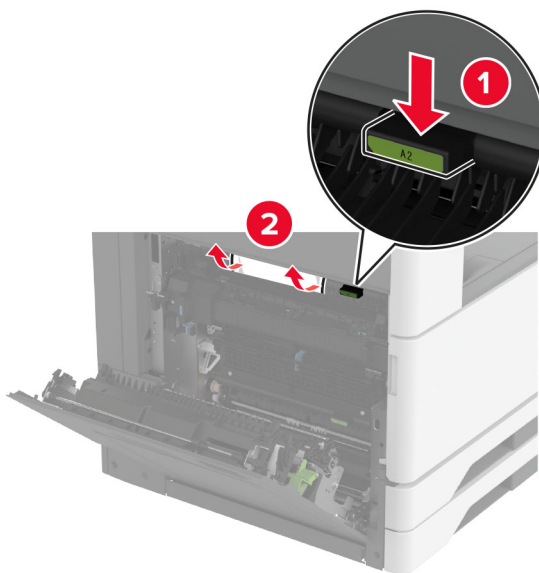

- 3 Close door A1, and then close door A.
- 4 Lift the paper transport cover F, and then remove the jammed paper.
Note: Make sure that all paper fragments are removed.

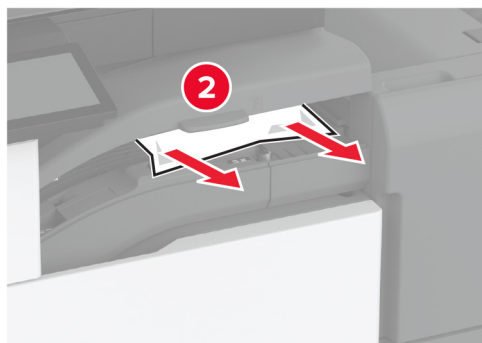
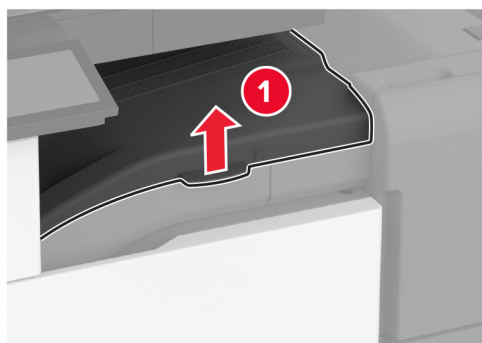

- 5 Close the cover.

- 6 Pull the lever on the staple, hole punch finisher and then lift the cover.

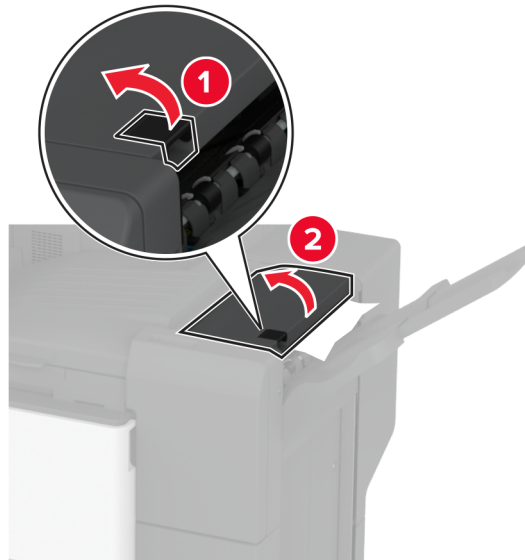

- 7 Remove the jammed paper.

Note: Make sure that all paper fragments are removed.

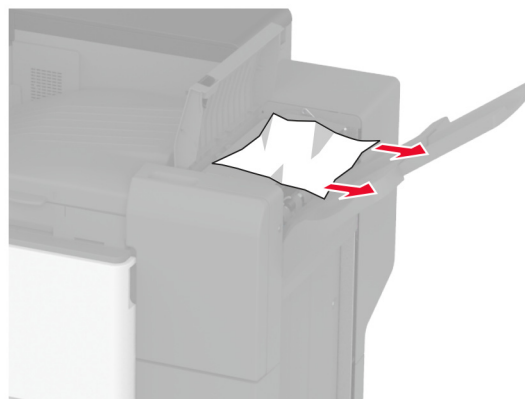

- 8 Close the cover.

Paper jam in the trifold/Z-fold finisher

- 1 Open door A.



CAUTION—HOT SURFACE: The inside of the printer might be hot. To reduce the risk of injury from a hot component, allow the surface to cool before touching it.

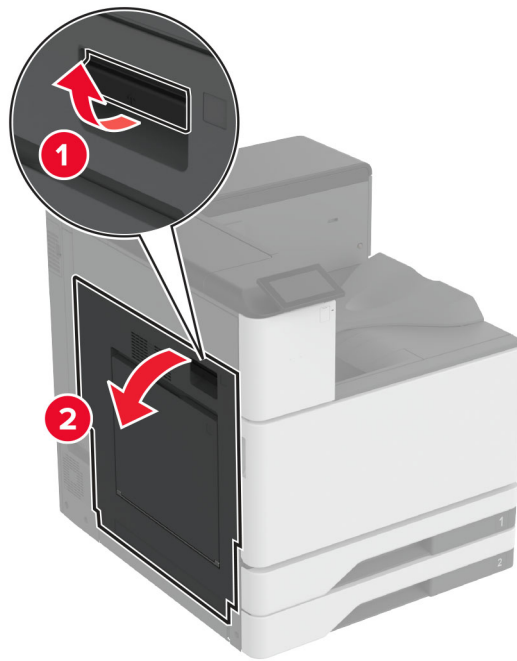

2 Open door A1, and then remove the jammed paper.

Note: Make sure that all paper fragments are removed.

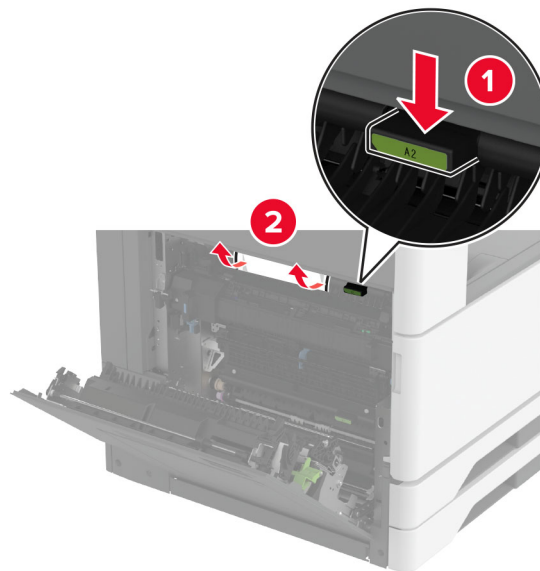

3 Close door A1, and then close door A.

4 Lift the paper transport cover F, and then remove the jammed paper.

Note: Make sure that all paper fragments are removed.

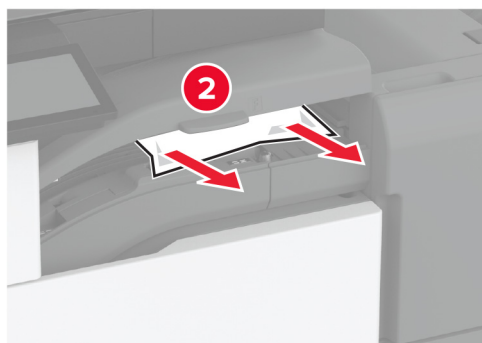

5 Close the cover.

6 Open the trifold/Z-fold finisher door.

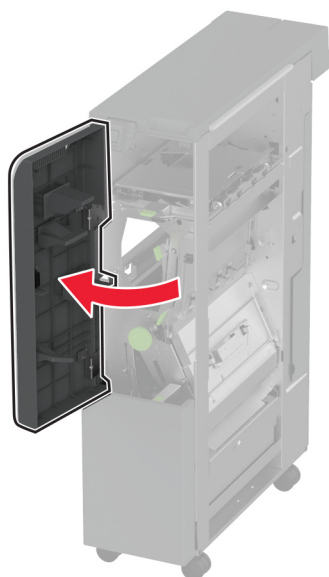

7 Remove the jammed paper from any of the following locations.

Note: Make sure that all paper fragments are removed.

- Handle 2A

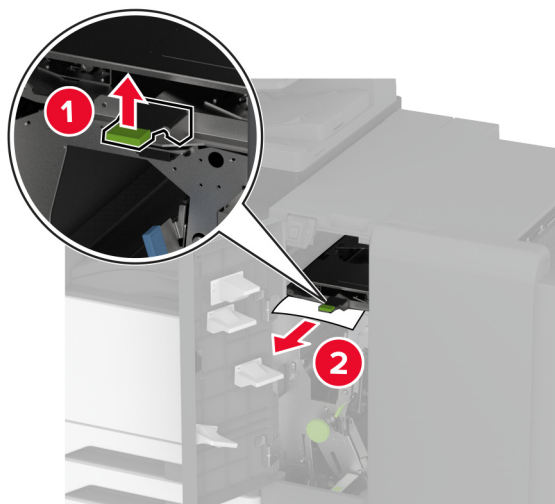

Note: Make sure to return the handle to its original position.

- Handle 2B

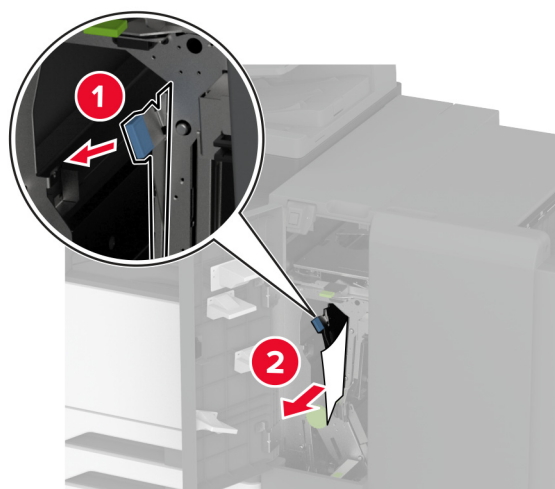

Note: Make sure to return the handle to its original position.

8 Pull out the finisher bin.

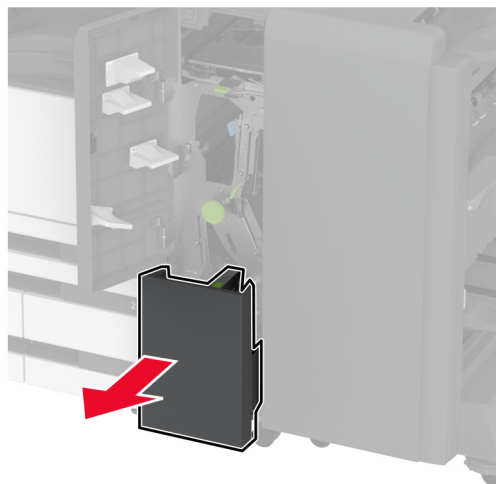

9 Remove the jammed paper from any of the following locations.

Note: Make sure that all paper fragments are removed.

- Handle 2E

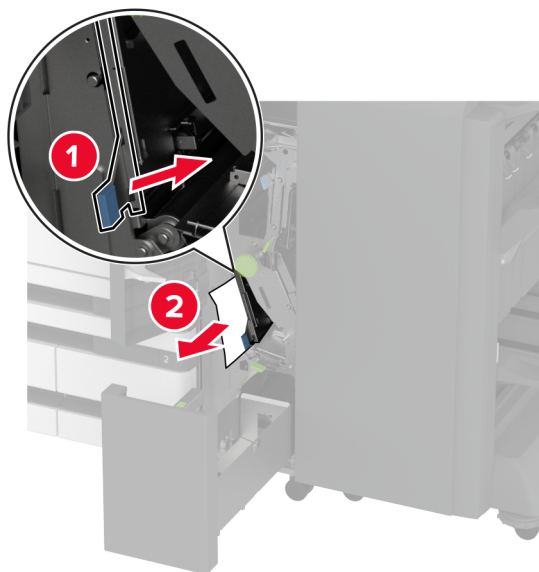

Note: Make sure to return the handle to its original position.

- Knob 2C

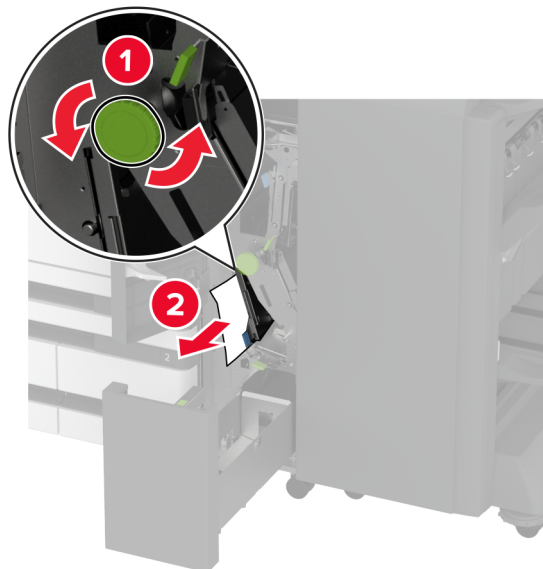

- Handle 2F

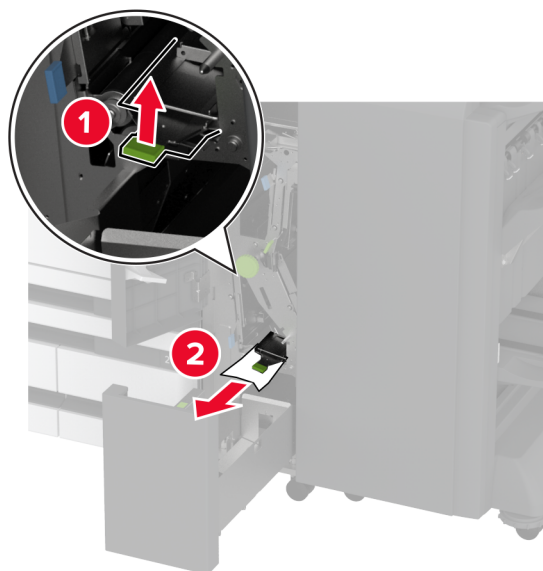

Note: Make sure to return the handle to its original position.

- Handle 2G

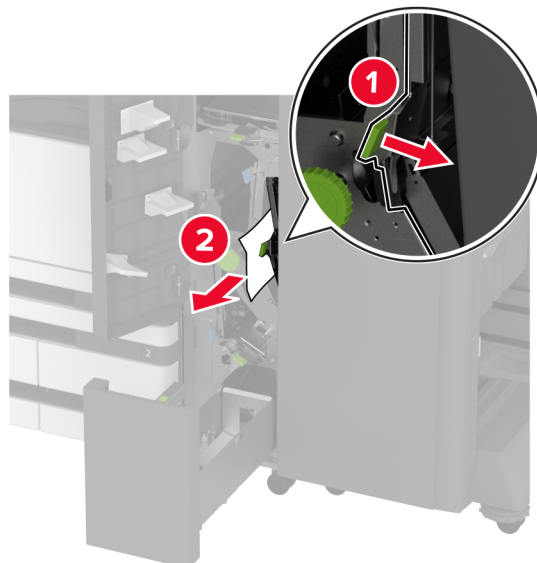

Note: Make sure to return the handle to its original position.

10 Push the finisher bin back into place, and then close the trifold/Z-fold finisher door.

11 Open the booklet finisher door.

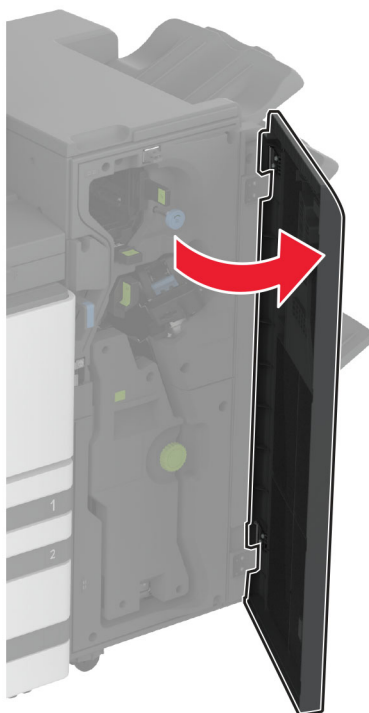

12 Remove the jammed paper from any of the following locations.

Note: Make sure that all paper fragments are removed.

- Handle 3A

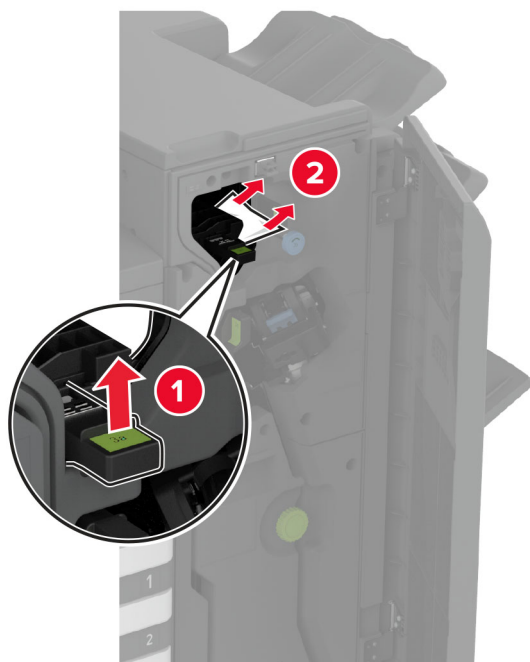

Note: Make sure to return the handle to its original position.

- Knob 3B

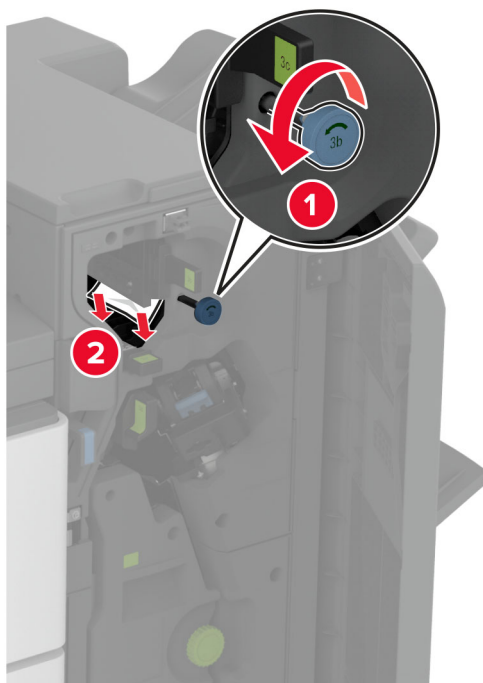

- Handle 3C

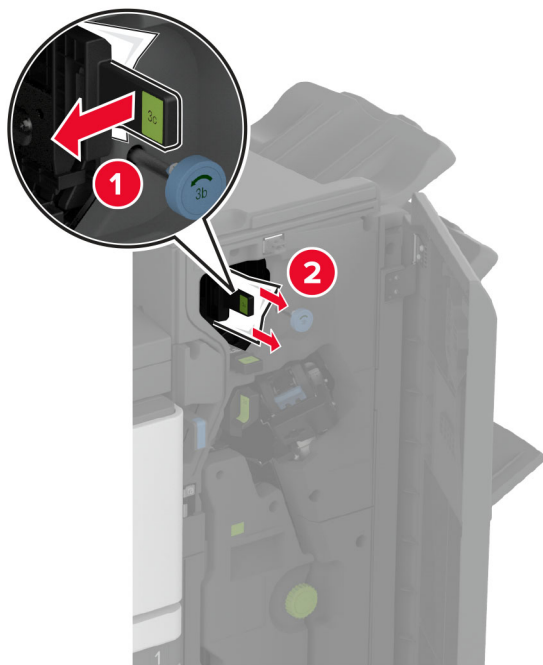

Note: Make sure to return the handle to its original position.

- Handle 3D

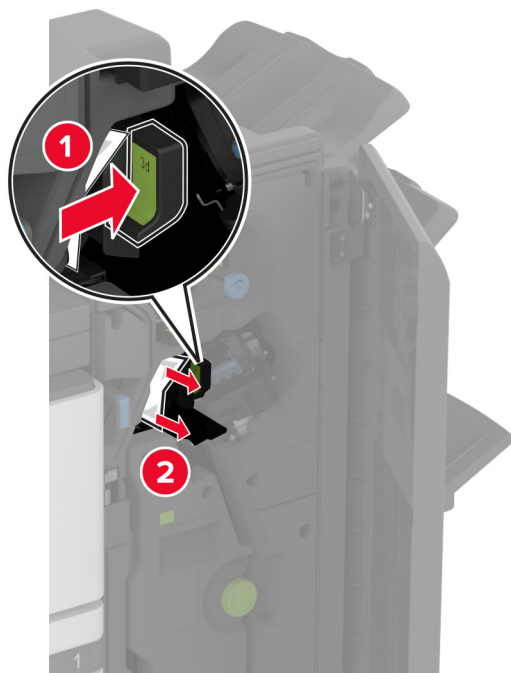

Note: Make sure to return the handle to its original position.

- 13** Pull out the booklet maker.

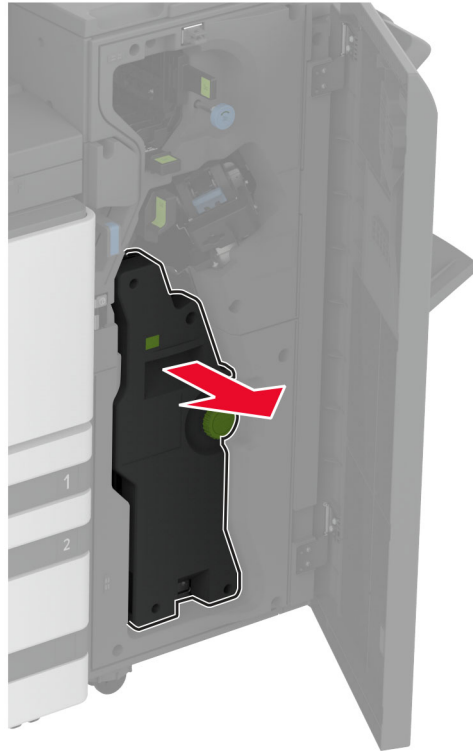

- 14** Turn knob 4A, and then remove the jammed paper.

Note: Make sure that all paper fragments are removed.

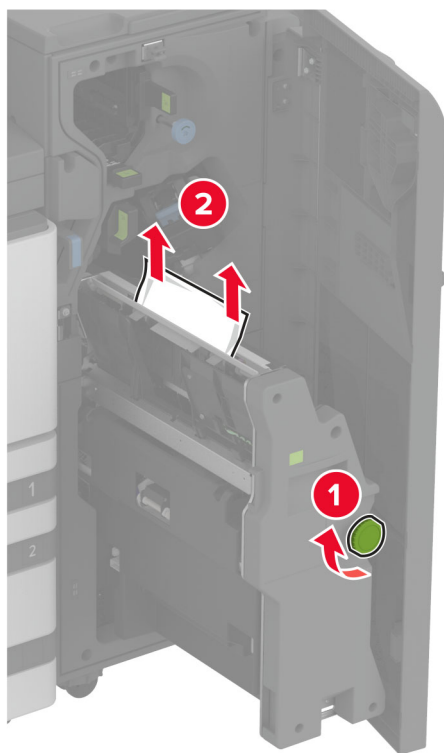

15 Push the booklet maker back into place, and then close the finisher door.

Paper jam in the booklet finisher

1 Open door A.

 **CAUTION—HOT SURFACE:** The inside of the printer might be hot. To reduce the risk of injury from a hot component, allow the surface to cool before touching it.

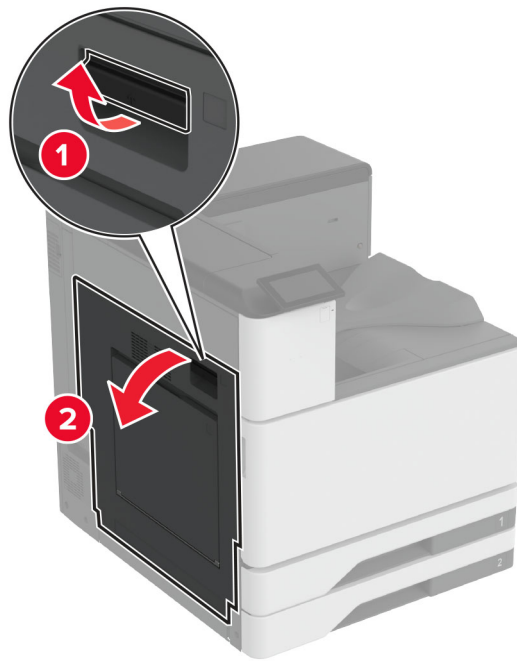

2 Open door A1, and then remove the jammed paper.

Note: Make sure that all paper fragments are removed.

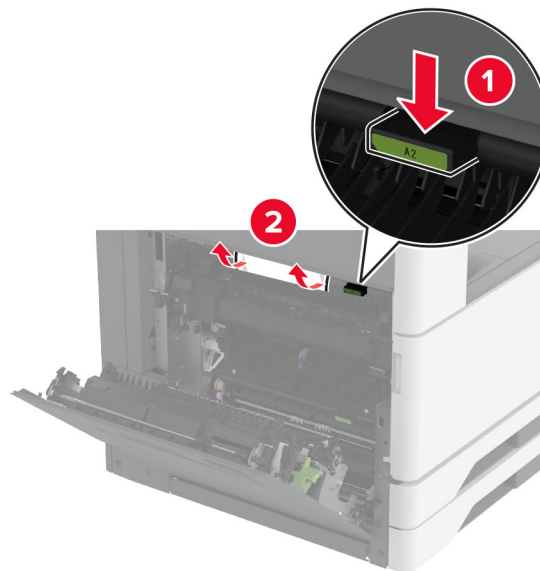

3 Close door A1, and then close door A.

4 Lift the paper transport cover, and then remove the jammed paper.

Note: Make sure that all paper fragments are removed.

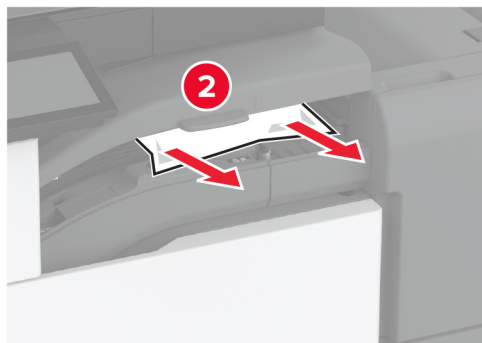
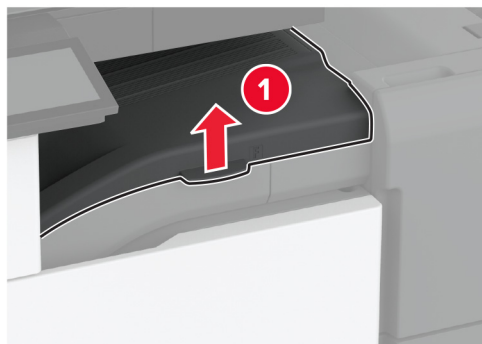

5 Close the cover.

6 Open the booklet finisher door.

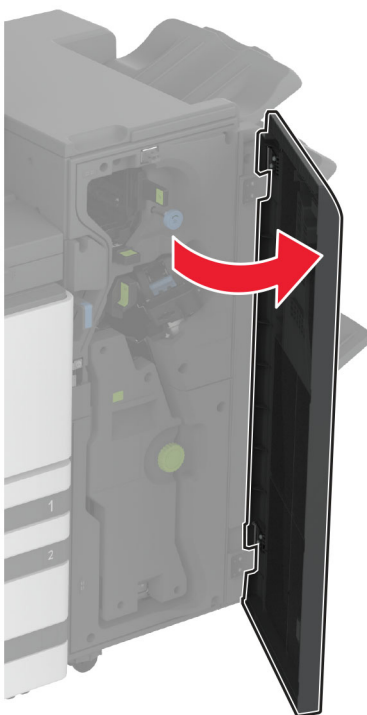

7 Remove the jammed paper from any of the following locations.

- Handle 3A

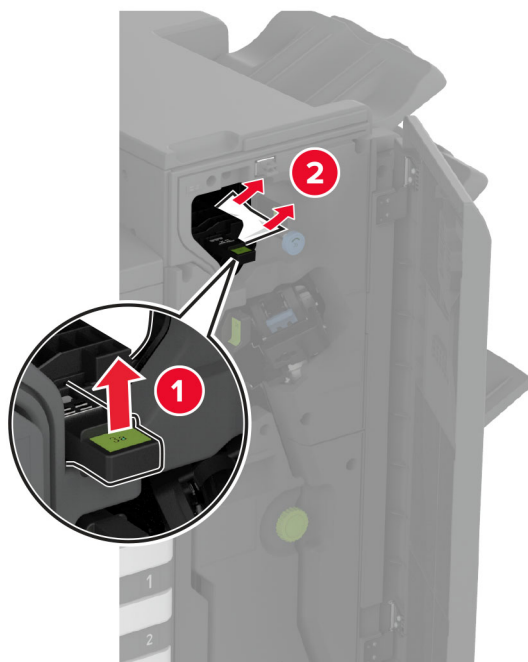

Note: Make sure to return the handle to its original position.

- Knob 3B

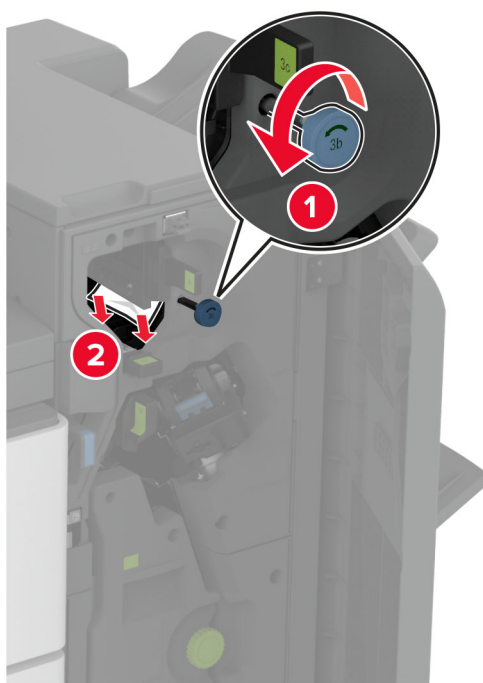

Note: Make sure to return the handle to its original position.

- Handle 3C

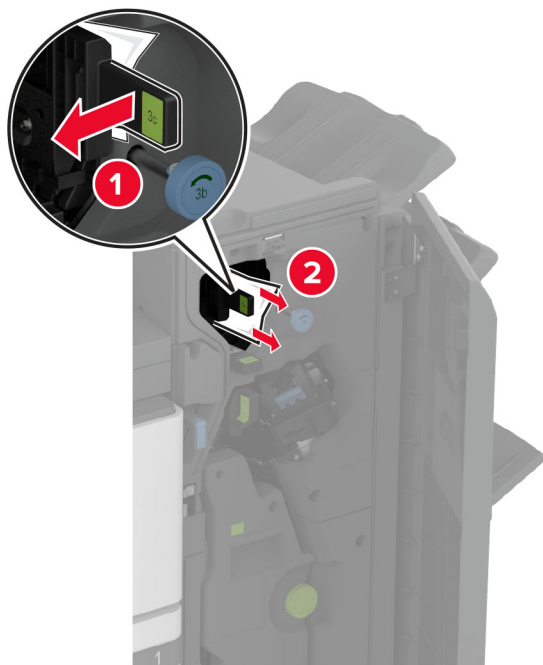

Note: Make sure to return the handle to its original position.

- Handle 3D

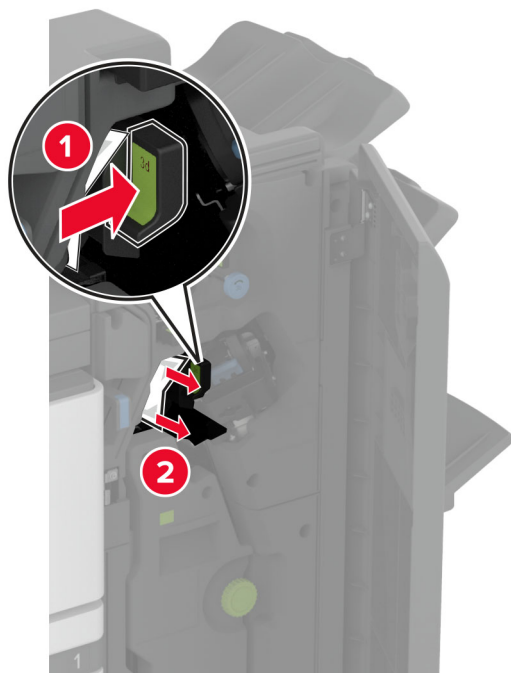

Note: Make sure to return the handle to its original position.

8 Pull out the booklet maker.



9 Turn knob 4A, and then remove the jammed paper.

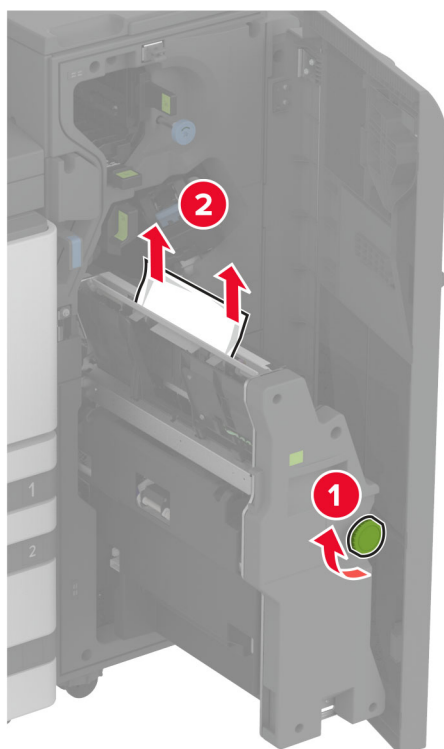

10 Push the booklet maker back into place, and then close the finisher door.

Network connection problems

Cannot open Embedded Web Server

Action	Yes	No
<p>Step 1</p> <p>a Check if the printer is on.</p> <p>b Access the printer Embedded Web Server (EWS).</p> <p>Can you open the EWS?</p>	The problem is solved.	Go to step 2.
<p>Step 2</p> <p>a Make sure that the printer IP address is correct.</p> <p>Notes:</p> <ul style="list-style-type: none"> • View the IP address on the home screen. • An IP address appears as four sets of numbers separated by periods, such as 123.123.123.123. <p>b Access the EWS.</p> <p>Can you open the EWS?</p>	The problem is solved.	Go to step 3.
<p>Step 3</p> <p>a Make sure that you installed a supported browser:</p> <ul style="list-style-type: none"> • Internet Explorer version 11 or later • Microsoft Edge • Safari version 6 or later • Google Chrome™ version 32 or later • Mozilla Firefox version 24 or later <p>b Access the EWS.</p> <p>Can you open the EWS?</p>	The problem is solved.	Go to step 4.
<p>Step 4</p> <p>a Check if the network connection is working.</p> <p>Note: If the connection is not working, then contact your administrator.</p> <p>b Access the EWS.</p> <p>Can you open the EWS?</p>	The problem is solved.	Go to step 5.
<p>Step 5</p> <p>a Make sure that the cable connections to the printer and print server are secure. For more information, see the documentation that came with the print server.</p> <p>b Access the EWS.</p> <p>Can you open the EWS?</p>	The problem is solved.	Go to step 6.

Action	Yes	No
<p>Step 6</p> <p>a Check if the web proxy servers are disabled.</p> <p>Note: If the servers are disabled, then contact your administrator.</p> <p>b Access the EWS.</p> <p>Can you open the EWS?</p>	<p>The problem is solved.</p>	<p>Contact customer support.</p>

Cannot connect the printer to the Wi-Fi network

Action	Yes	No
<p>Step 1</p> <p>Make sure that Active Adapter is set to Auto.</p> <p>From the home screen, touch Settings > Network/Ports > Network Overview > Active Adapter > Auto.</p> <p>Can the printer connect to the Wi-Fi network?</p>	<p>The problem is solved.</p>	<p>Go to step 2.</p>
<p>Step 2</p> <p>Check if the correct Wi-Fi network is selected.</p> <p>Note: Some routers may share the default SSID.</p> <p>Are you connecting to the correct Wi-Fi network?</p>	<p>Go to step 4.</p>	<p>Go to step 3.</p>
<p>Step 3</p> <p>Connect to the correct Wi-Fi network. For more information, see “Connecting the printer to a Wi-Fi network” on page 160.</p> <p>Can the printer connect to the Wi-Fi network?</p>	<p>The problem is solved.</p>	<p>Go to step 4.</p>
<p>Step 4</p> <p>Check the wireless security mode.</p> <p>From the home screen, touch Settings > Network/Ports > Wireless > Wireless Security Mode.</p> <p>Is the correct wireless security mode selected?</p>	<p>Go to step 6.</p>	<p>Go to step 5.</p>
<p>Step 5</p> <p>Select the correct wireless security mode.</p> <p>Can the printer connect to the Wi-Fi network?</p>	<p>The problem is solved.</p>	<p>Go to step 6.</p>
<p>Step 6</p> <p>Make sure that you entered the correct network password.</p> <p>Note: Take note of the spaces, numbers, and capitalization in the password.</p> <p>Can the printer connect to the Wi-Fi network?</p>	<p>The problem is solved.</p>	<p>Contact customer support.</p>

Hardware options problems

Cannot detect internal option

Action	Yes	No
<p>Step 1 Turn off the printer, wait for about 10 seconds, and then turn on the printer.</p> <p>Does the internal option operate correctly?</p>	The problem is solved.	Go to step 2.
<p>Step 2 Print the Menu Settings Page, and then check if the internal option appears in the Installed Features list.</p> <p>Is the internal option listed in the menu settings page?</p>	Go to step 4.	Go to step 3.
<p>Step 3 Check if the internal option is installed properly into the controller board.</p> <ul style="list-style-type: none"> a Turn off the printer, and then unplug the power cord from the electrical outlet. b Make sure that the internal option is installed in the appropriate connector in the controller board. c Connect the power cord to the electrical outlet, and then turn on the printer. <p> CAUTION—POTENTIAL INJURY: To avoid the risk of fire or electrical shock, connect the power cord to an appropriately rated and properly grounded electrical outlet that is near the product and easily accessible.</p> <p>Does the internal option operate correctly?</p>	The problem is solved.	Go to step 4.
<p>Step 4</p> <ul style="list-style-type: none"> a Check if the internal option is available in the print driver. Note: If necessary, manually add the internal option in the print driver to make it available for print jobs. For more information, see “Adding available options in the print driver” on page 61. b Resend the print job. <p>Does the internal option operate correctly?</p>	The problem is solved.	Contact customer support .

Internal solutions port does not operate correctly

Action	Yes	No
<p>Step 1 Print a menu settings page, and then check if the internal solutions port (ISP) appears in the Installed Features list.</p> <p>Is the ISP listed in the Installed Features list?</p>	Go to step 3.	Go to step 2.
<p>Step 2 Remove, and then install the ISP. For more information, see “Installing an internal solutions port” on page 152.</p> <p>Note: Use a supported ISP.</p> <p>Does the ISP operate correctly?</p>	The problem is solved.	Go to step 3.
<p>Step 3 Check the cable and the ISP connection.</p> <ul style="list-style-type: none"> a Use the correct cable, and then make sure that it is securely connected to the ISP. b Check if the ISP solution interface cable is securely connected into the receptacle of the controller board. <p>Does the ISP operate correctly?</p>	The problem is solved.	Contact customer support .

Parallel or serial interface card does not operate correctly

Action	Yes	No
<p>Step 1 Print a menu settings page, and then check if the parallel or serial interface card appears in the Installed Features list.</p> <p>Is the parallel or serial interface card listed in the Installed Features list?</p>	Go to step 3.	Go to step 2.
<p>Step 2 Remove, and then install the parallel or serial interface card. For more information, see “Installing an internal solutions port” on page 152.</p> <p>Does the parallel or serial interface card operate correctly?</p>	The problem is solved.	Go to step 3.
<p>Step 3 Check the connection between the cable and the parallel or serial interface card.</p> <p>Does the parallel or serial interface card operate correctly?</p>	The problem is solved.	Contact customer support .

Defective flash detected

Try one or more of the following:

- Replace the defective intelligent storage drive.
- From the home screen, touch **Continue** to ignore the message and continue printing.
- Cancel the current print job.

Not enough free space in flash memory for resources

Try one or more of the following:

- Touch **Continue** to clear the message and continue printing.
- Delete fonts, macros, and other data stored in the flash memory.
- Install a hard disk.

Note: Downloaded fonts and macros that are not previously stored in the flash memory are deleted.

Issues with supplies

Missing or unresponsive toner cartridge

Action	Yes	No
<p>Step 1</p> <p>a Open the front door.</p> <p>b Remove, and then insert the toner cartridge.</p> <p>Is the toner cartridge missing or unresponsive?</p>	Go to step 2.	The problem is solved.
<p>Step 2</p> <p>Check if the printer is using a genuine and supported Lexmark toner cartridge.</p> <p>Note: If the toner cartridge is not supported, then install a supported one.</p> <p>Is the toner cartridge missing or unresponsive?</p>	Contact customer support .	The problem is solved.

Non-Lexmark supply

The printer has detected a non-Lexmark supply or part installed in the printer.

Your Lexmark printer is designed to function best with genuine Lexmark supplies and parts. Use of third-party supplies or parts may affect the performance, reliability, or life of the printer and its imaging components.

All life indicators are designed to function with Lexmark supplies and parts and may deliver unpredictable results if third-party supplies or parts are used. Imaging component usage beyond the intended life may damage your Lexmark printer or associated components.

Warning—Potential Damage: Use of third-party supplies or parts can affect warranty coverage. Damage caused by the use of third-party supplies or parts may not be covered by the warranty.

To accept any and all of these risks and to proceed with the use of non-genuine supplies or parts in your printer, touch and hold the error message on the display using two fingers for 15 seconds. When a confirmation dialog box appears, touch **Continue**.

If you do not want to accept these risks, then remove the third-party supply or part from your printer and install a genuine Lexmark supply or part. For more information, see [“Using genuine Lexmark parts and supplies” on page 223](#).

If the printer does not print after clearing the error message, then reset the supply usage counter.

- 1 From the home screen, touch **Settings > Device > Maintenance > Configuration Menu > Supply Usage And Counters**.
- 2 Select the part or supply that you want to reset, and then touch **Start**.
- 3 Read the warning message, and then touch **Continue**.
- 4 Using two fingers, touch the display for 15 seconds to clear the message.

Note: If you are unable to reset the supply usage counters, then return the supply item to the place of purchase.

Paper feed problems

Envelope seals when printing

Action	Yes	No
<p>Step 1</p> <p>a Use an envelope that has been stored in a dry environment. Note: Printing on envelopes with high moisture content can seal the flaps.</p> <p>b Send the print job.</p> <p>Does the envelope seal when printing?</p>	Go to step 2.	The problem is solved.
<p>Step 2</p> <p>a Make sure that paper type is set to Envelope. From the home screen, touch Settings > Paper > Tray Configuration > Paper Size/Type.</p> <p>b Send the print job.</p> <p>Does the envelope seal when printing?</p>	Contact customer support .	The problem is solved.

Collated printing does not work

Action	Yes	No
<p>Step 1</p> <p>a From the home screen, touch Settings > Print > Layout > Collate.</p> <p>b Touch On [1,2,1,2,1,2].</p> <p>c Print the document.</p> <p>Is the document collated correctly?</p>	The problem is solved.	Go to step 2.
<p>Step 2</p> <p>a From the document that you are trying to print, open the Print dialog box, and then select Collate.</p> <p>b Print the document.</p> <p>Is the document collated correctly?</p>	The problem is solved.	Go to step 3.
<p>Step 3</p> <p>a Reduce the number of pages to print.</p> <p>b Print the document.</p> <p>Are the pages collated correctly?</p>	The problem is solved.	Contact customer support .

Tray linking does not work

Action	Yes	No
<p>Step 1</p> <p>a Check if the trays contain the same paper size and paper type.</p> <p>b Check if the paper guides are positioned correctly.</p> <p>c Print the document.</p> <p>Do the trays link correctly?</p>	The problem is solved.	Go to step 2.
<p>Step 2</p> <p>a From the home screen, touch Settings > Paper > Tray Configuration > Paper Size/Type.</p> <p>b Set the paper size and paper type to match the paper loaded in the linked trays.</p> <p>c Print the document.</p> <p>Do the trays link correctly?</p>	The problem is solved.	Go to step 3.
<p>Step 3</p> <p>a Make sure that Tray Linking is set to Automatic. For more information, see “Linking trays” on page 58.</p> <p>b Print the document.</p> <p>Do the trays link correctly?</p>	The problem is solved.	Contact customer support .

Paper frequently jams

Action	Yes	No
<p>Step 1</p> <p>a Remove the tray.</p> <p>b Check if paper is loaded correctly.</p> <p>Notes:</p> <ul style="list-style-type: none"> • Make sure that the paper guides are positioned correctly. • Make sure that the stack height is below the maximum paper fill indicator. • Make sure to print on recommended paper size and type. <p>c Insert the tray.</p> <p>d Print the document.</p> <p>Do paper jams occur frequently?</p>	Go to step 2.	The problem is solved.
<p>Step 2</p> <p>a From the home screen, touch Settings > Paper > Tray Configuration > Paper Size/Type.</p> <p>b Set the correct paper size and type.</p> <p>c Print the document.</p> <p>Do paper jams occur frequently?</p>	Go to step 3.	The problem is solved.
<p>Step 3</p> <p>a Load paper from a fresh package.</p> <p>Note: Paper absorbs moisture due to high humidity. Store paper in its original wrapper until you are ready to use it.</p> <p>b Print the document.</p> <p>Do paper jams occur frequently?</p>	Contact customer support .	The problem is solved.

Jammed pages are not reprinted

Action	Yes	No
<p>a From the home screen, touch Settings > Device > Notifications > Jam Content Recovery.</p> <p>b In the Jam Recovery menu, touch On or Auto.</p> <p>c Print the document.</p> <p>Are the jammed pages reprinted?</p>	The problem is solved.	Contact customer support .

Color quality problems

Modifying the colors in printed output

- 1 From the home screen, touch **Settings > Print > Quality > Advanced Imaging > Color Correction**.
- 2 In the Color Correction menu, touch **Manual > Color Correction Content**.
- 3 Choose the appropriate color conversion setting.

Object type	Color conversion tables
RGB Image RGB Text RGB Graphics	<ul style="list-style-type: none"> • Vivid—Produces brighter, more saturated colors and may be applied to all incoming color formats. • sRGB Display—Produces an output that approximates the colors shown on a computer monitor. Black toner usage is optimized for printing photographs. • Display-True Black—Produces an output that approximates the colors shown on a computer monitor. This setting uses only black toner to create all levels of neutral gray. • sRGB Vivid—Provides an increased color saturation for the sRGB Display color correction. Black toner usage is optimized for printing business graphics. • Off
CMYK Image CMYK Text CMYK Graphics	<ul style="list-style-type: none"> • US CMYK—Applies color correction to approximate the Specifications for Web Offset Publishing (SWOP) color output. • Euro CMYK—Applies color correction to approximate Euroscale color output. • Vivid CMYK—Increases the color saturation of the US CMYK color correction setting. • Off

FAQ about color printing

What is RGB color?

RGB color is a method of describing colors by indicating the amount of red, green, or blue used to produce a certain color. Red, green, and blue light can be added in various amounts to produce a large range of colors observed in nature. Computer screens, scanners, and digital cameras use this method to display colors.

What is CMYK color?

CMYK color is a method of describing colors by indicating the amount of cyan, magenta, yellow, and black used to reproduce a particular color. Cyan, magenta, yellow, and black inks or toners can be printed in various amounts to produce a large range of colors observed in nature. Printing presses, inkjet printers, and color laser printers create colors in this manner.

How is color specified in a document to be printed?

Software programs are used to specify and modify the document color using RGB or CMYK color combinations. For more information, see the software program Help topics.

How does the printer know what color to print?

When printing a document, information describing the type and color of each object is sent to the printer and is passed through color conversion tables. Color is translated into the appropriate amounts of cyan, magenta, yellow, and black toner used to produce the color you want. The object information determines the application of color conversion tables. For example, it is possible to apply one type of color conversion table to text while applying a different color conversion table to photographic images.

What is manual color correction?

When manual color correction is enabled, the printer employs user-selected color conversion tables to process objects. Manual color correction settings are specific to the type of object being printed (text, graphics, or images). It is also specific to how the color of the object is specified in the software program (RGB or CMYK combinations). To apply a different color conversion table manually, see [“Modifying the colors in printed output” on page 399](#).

If the software program does not specify colors with RGB or CMYK combinations, then manual color correction is not useful. It is also not effective if the software program or the computer operating system controls the adjustment of colors. In most situations, setting the Color Correction to Auto generates preferred colors for the documents.

How can I match a particular color (such as a corporate logo)?

From the printer Quality menu, nine types of Color Samples sets are available. These sets are also available from the Color Samples page of the Embedded Web Server. Selecting any sample set generates multiple-page prints consisting of hundreds of colored boxes. Each box contains a CMYK or RGB combination, depending on the table selected. The observed color of each box is obtained by passing the CMYK or RGB combination labeled on the box through the selected color conversion table.

By examining Color Samples sets, you can identify the box with color closest to the color being matched. The color combination labeled on the box can then be used for modifying the color of the object in a software program. For more information, see the software program Help topics. Manual color correction may be necessary to use the selected color conversion table for the particular object.

Selecting which Color Samples set to use for a particular color-matching problem depends on:

- The Color Correction setting being used (Auto, Off, or Manual)
- The type of object being printed (text, graphics, or images)
- How the color of the object is specified in the software program (RGB or CMYK combinations)

If the software program does not specify colors with RGB or CMYK combinations, then the Color Samples pages are not useful. Additionally, some software programs adjust the RGB or CMYK combinations specified in the program through color management. In these situations, the printed color may not be an exact match of the Color Samples pages.

The print appears tinted

Action	Yes	No
<p>Step 1 Perform Color Adjust.</p> <p>a From the home screen, touch Settings > Print > Quality > Advanced Imaging > Color Adjust.</p> <p>b Print the document.</p> <p>Does the print appear tinted?</p>	Go to step 2.	The problem is solved.

Action	Yes	No
<p>Step 2</p> <p>Perform Color Balance.</p> <p>a From the home screen, touch Settings > Print > Quality > Advanced Imaging > Color Balance.</p> <p>b Adjust the settings.</p> <p>c Print the document.</p> <p>Does the print appear tinted?</p>	<p>Contact customer support.</p>	<p>The problem is solved.</p>

Contacting customer support

Before contacting customer support, make sure to have the following information:

- Printer problem
- Error message
- Printer model type and serial number

Go to <http://support.lexmark.com> to receive e-mail or chat support, or browse through the library of manuals, support documentation, drivers, and other downloads.

Technical support via telephone is also available. In the U.S. or Canada, call 1-800-539-6275. For other countries or regions, go to <http://support.lexmark.com>.

Recycle and dispose

Recycling Lexmark products

To return Lexmark products for recycling:

- 1 Go to www.lexmark.com/recycle.
- 2 Select the product you want to recycle.

Note: Printer supplies and hardware not listed in the Lexmark Collection and Recycling Program may be recycled through your local recycling center.

Recycling Lexmark packaging

Lexmark continually strives to minimize packaging. Less packaging helps to ensure that Lexmark printers are transported in the most efficient and environmentally sensitive manner and that there is less packaging to dispose of. These efficiencies result in fewer greenhouse emissions, energy savings, and natural resource savings. Lexmark also offers recycling of packaging components in some countries or regions. For more information, go to www.lexmark.com/recycle, and then choose your country or region. Information on available packaging recycling programs is included with the information on product recycling.

Lexmark cartons are 100% recyclable where corrugated recycling facilities exist. Facilities may not exist in your area.

The foam used in Lexmark packaging is recyclable where foam recycling facilities exist. Facilities may not exist in your area.

When you return a cartridge to Lexmark, you can reuse the box that the cartridge came in. Lexmark recycles the box.

Notices

Product information

Product name:

Lexmark CS943de printer

Machine type:

5080

Model:

435

Edition notice

October 2022

The following paragraph does not apply to any country where such provisions are inconsistent with local law: LEXMARK INTERNATIONAL, INC., PROVIDES THIS PUBLICATION "AS IS" WITHOUT WARRANTY OF ANY KIND, EITHER EXPRESS OR IMPLIED, INCLUDING, BUT NOT LIMITED TO, THE IMPLIED WARRANTIES OF MERCHANTABILITY OR FITNESS FOR A PARTICULAR PURPOSE. Some states do not allow disclaimer of express or implied warranties in certain transactions; therefore, this statement may not apply to you.

This publication could include technical inaccuracies or typographical errors. Changes are periodically made to the information herein; these changes will be incorporated in later editions. Improvements or changes in the products or the programs described may be made at any time.

References in this publication to products, programs, or services do not imply that the manufacturer intends to make these available in all countries in which it operates. Any reference to a product, program, or service is not intended to state or imply that only that product, program, or service may be used. Any functionally equivalent product, program, or service that does not infringe any existing intellectual property right may be used instead. Evaluation and verification of operation in conjunction with other products, programs, or services, except those expressly designated by the manufacturer, are the user's responsibility.

For Lexmark technical support, go to <http://support.lexmark.com>.

For information on Lexmark's privacy policy governing the use of this product, go to www.lexmark.com/privacy.

For information on supplies and downloads, go to www.lexmark.com.

© 2022 Lexmark International, Inc.

All rights reserved.

GOVERNMENT END USERS

The Software Program and any related documentation are "Commercial Items," as that term is defined in 48 C.F.R. 2.101, "Computer Software" and "Commercial Computer Software Documentation," as such terms are used in 48 C.F.R. 12.212 or 48 C.F.R. 227.7202, as applicable. Consistent with 48 C.F.R. 12.212 or 48 C.F.R. 227.7202-1 through 227.7207-4, as applicable, the Commercial Computer Software and Commercial Software

Documentation are licensed to the U.S. Government end users (a) only as Commercial Items and (b) with only those rights as are granted to all other end users pursuant to the terms and conditions herein.

Trademarks

Lexmark and the Lexmark logo are trademarks or registered trademarks of Lexmark International, Inc. in the United States and/or other countries.

Android, Google Play, and Google Chrome are trademarks of Google LLC.

Macintosh, macOS, Safari, and AirPrint are trademarks of Apple Inc., registered in the U.S. and other countries. App Store is a service mark of Apple Inc., registered in the U.S. and other countries. Use of the Works with Apple badge means that an accessory has been designed to work specifically with the technology identified in the badge and has been certified by the developer to meet Apple performance standards.

Microsoft, Internet Explorer, Microsoft Edge, and Windows are trademarks of the Microsoft group of companies.

The Mopria® word mark is a registered and/or unregistered trademark of Mopria Alliance, Inc. in the United States and other countries. Unauthorized use is strictly prohibited.

PCL® is a registered trademark of the Hewlett-Packard Company. PCL is Hewlett-Packard Company’s designation of a set of printer commands (language) and functions included in its printer products. This printer is intended to be compatible with the PCL language. This means the printer recognizes PCL commands used in various application programs, and that the printer emulates the functions corresponding to the commands.

PostScript is a registered trademark of Adobe Systems Incorporated in the United States and/or other countries.

Wi-Fi® and Wi-Fi Direct® are registered trademarks of Wi-Fi Alliance®.

All other trademarks are the property of their respective owners.

Licensing notices

All licensing notices associated with this product can be viewed from the CD:\NOTICES directory of the installation software CD.

Noise emission levels

The following measurements were made in accordance with ISO 7779 and reported in conformance with ISO 9296.

Note: Some modes may not apply to your product.

1-meter average sound pressure, dBA	
Printing	One-sided: 50 Two-sided: 52
Ready	15

Values are subject to change. See www.lexmark.com for current values.

Waste from Electrical and Electronic Equipment (WEEE) directive

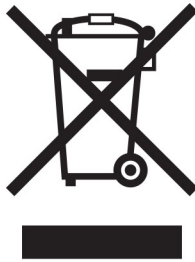

The WEEE logo signifies specific recycling programs and procedures for electronic products in countries of the European Union. We encourage the recycling of our products.

If you have further questions about recycling options, visit the Lexmark Web site at www.lexmark.com for your local sales office phone number.

India E-Waste notice

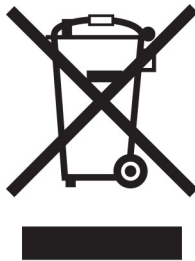

This product including components, consumables, parts and spares complies with the “India E-Waste Rules” and prohibits use of lead, mercury, hexavalent chromium, polybrominated biphenyls or polybrominated diphenyl ethers in concentrations exceeding 0.1% by weight and 0.01% by weight for cadmium, except for the exemption set in the Rule.

Lithium-ion rechargeable battery

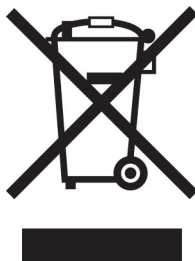

This product may contain a coin-cell, lithium-ion rechargeable battery, which should only be removed by a trained technician. Crossed-out wheeled bin means the product should not be discarded as unsorted waste but must be sent to separate collection facilities for recovery and recycling. In the event the battery is removed, do not dispose of the battery in your household waste. There may be separate collection systems for batteries in your local community, such as a battery-recycling drop-off location. The separate collection of waste batteries

assures appropriate treatment of waste including reuse and recycling and prevents any potential negative effects on human health and environment. Please responsibly dispose of the batteries.

Product disposal

Do not dispose of the printer or supplies in the same manner as normal household waste. Consult your local authorities for disposal and recycling options.

Returning Lexmark cartridges for reuse or recycling

The Lexmark Cartridge Collection Program allows you to return used cartridges for free to Lexmark for reuse or recycling. One hundred percent of the empty cartridges returned to Lexmark are either reused or demanufactured for recycling. The boxes used to return the cartridges are also recycled.

To return Lexmark cartridges for reuse or recycling, do the following:

- 1 Go to www.lexmark.com/recycle.
- 2 Select the product that you want to recycle.

Static sensitivity notice



This symbol identifies static-sensitive parts. Do not touch the areas near these symbols without first touching a metal surface in an area away from the symbol.

To prevent damage from electrostatic discharge when performing maintenance tasks such as clearing paper jams or replacing supplies, touch any exposed metal frame of the printer before accessing or touching interior areas of the printer even if the symbol is not present.

ENERGY STAR

Any Lexmark product bearing the ENERGY STAR® emblem on the product or on a start-up screen is certified to comply with Environmental Protection Agency (EPA) ENERGY STAR requirements as of the date of manufacture.



Temperature information

Operating temperature and relative humidity	10 to 32.2°C (50 to 90°F) and 15 to 80% RH 15.6 to 32.2°C (60 to 90°F) and 8 to 80% RH Maximum wet-bulb temperature ² : 22.8°C (73°F) Non-condensing environment
Printer / cartridge / imaging unit long-term storage ¹	15.6 to 32.2°C (60 to 90°F) and 8 to 80% RH Maximum wet-bulb temperature ² : 22.8°C (73°F)
Printer / cartridge / imaging unit short-term shipping	-40 to 40°C (-40 to 104°F)
<p>¹ Supplies shelf life is approximately 2 years. This is based on storage in a standard office environment at 22°C (72°F) and 45% humidity.</p> <p>² Wet-bulb temperature is determined by the air temperature and the relative humidity.</p>	

Power consumption

Product power consumption

The following table documents the power consumption characteristics of the product.

Note: Some modes may not apply to your product.

Mode	Description	Power consumption (Watts)
Printing	The product is generating hard-copy output from electronic inputs.	One-sided: 767 Two-sided: 700
Copy	The product is generating hard-copy output from hard-copy original documents.	N/A
Scan	The product is scanning hard-copy documents.	N/A
Ready	The product is waiting for a print job.	76
Sleep Mode	The product is in a high-level energy-saving mode.	1.3
Hibernate	The product is in a low-level energy-saving mode.	0.1
Off	The product is plugged into an electrical outlet, but the power switch is turned off.	0.1

The power consumption levels listed in the previous table represent time-averaged measurements. Instantaneous power draws may be substantially higher than the average.

Values are subject to change. See www.lexmark.com for current values.

Sleep Mode

This product is designed with an energy-saving mode called *Sleep Mode*. The Sleep Mode saves energy by lowering power consumption during extended periods of inactivity. The Sleep Mode is automatically engaged after this product is not used for a specified period of time, called the *Sleep Mode Timeout*.

Factory default Sleep Mode Timeout for this product (in minutes):	15
---	----

By using the configuration menus, the Sleep Mode Timeout can be modified between 1 minute and 120 minutes, or between 1 minute and 114 minutes, depending on the printer model. If the printer speed is less than or equal to 30 pages per minute, then you can set the timeout only up to 60 minutes or 54 minutes, depending on the printer model. Setting the Sleep Mode Timeout to a low value reduces energy consumption, but may increase the response time of the product. Setting the Sleep Mode Timeout to a high value maintains a fast response, but uses more energy.

Some models support a *Deep Sleep Mode*, which further reduces power consumption after longer periods of inactivity.

Hibernate Mode

This product is designed with an ultra-low power operating mode called *Hibernate mode*. When operating in Hibernate Mode, all other systems and devices are powered down safely.

The Hibernate mode can be entered in any of the following methods:

- Using the Hibernate Timeout
- Using the Schedule Power modes

Factory default Hibernate Timeout for this product in all countries or regions	3 days
--	--------

The amount of time the printer waits after a job is printed before it enters Hibernate mode can be modified between one hour and one month.

Notes on EPEAT-registered imaging equipment products:

- Standby power level occurs in Hibernate or Off mode.
- The product shall automatically power down to a standby power level of ≤ 1 W. The auto standby function (Hibernate or Off) shall be enabled at product shipment.

Off mode

If this product has an off mode which still consumes a small amount of power, then to completely stop product power consumption, disconnect the power supply cord from the electrical outlet.

Total energy usage

It is sometimes helpful to estimate the total product energy usage. Since power consumption claims are provided in power units of Watts, the power consumption should be multiplied by the time the product spends in each mode in order to calculate energy usage. The total product energy usage is the sum of each mode's energy usage.

Applicability of Regulation (EU) 2019/2015 and (EU) 2019/2020

Per Commission Regulation (EU) 2019/2015 and (EU) 2019/2020, the light source contained within this product or its component is intended to be used for Image Capture or Image Projection only, and is not intended for use in other applications.

Federal Communications Commission (FCC) compliance information statement

This product has been tested and found to comply with the limits for a Class A digital device, pursuant to Part 15 of the FCC Rules. Operation is subject to the following two conditions: (1) this device may not cause harmful interference, and (2) this device must accept any interference received, including interference that may cause undesired operation.

The FCC Class A limits are designed to provide reasonable protection against harmful interference when the equipment is operated in a commercial environment. This equipment generates, uses, and can radiate radio frequency energy and, if not installed and used in accordance with the instruction manual, may cause harmful interference to radio communications. Operation of this equipment in a residential area is likely to cause harmful interference, in which case the user will be required to correct the interference at his own expense.

The manufacturer is not responsible for any radio or television interference caused by using other than recommended cables or by unauthorized changes or modifications to this equipment. Unauthorized changes or modifications could void the user's authority to operate this equipment.

Note: To assure compliance with FCC regulations on electromagnetic interference for a Class A computing device, use a properly shielded and grounded cable such as Lexmark part number 1021231 for parallel attach or 1021294 for USB attach. Use of a substitute cable not properly shielded and grounded may result in a violation of FCC regulations.

Any questions regarding this compliance information statement should be directed to:

Director of Lexmark Technology & Services
Lexmark International, Inc.
740 West New Circle Road
Lexington, KY 40550
Telephone: (859) 232-2000
E-mail: regulatory@lexmark.com

Innovation, Science and Economic Development Canada compliance statement

This Class A digital apparatus meets all requirements of the Canadian Interference-Causing Equipment Standard ICES-003.

Avis de conformité aux normes de l'Innovation, Sciences et Développement économique Canada

Cet appareil numérique de classe A est conforme aux exigences de la norme canadienne relative aux équipements pouvant causer des interférences NMB-003.

Notice to users of Class A products in Brazil

Este produto não é apropriado para uso em ambientes domésticos, pois poderá causar interferências eletromagnéticas que obrigam o usuário a tomar medidas necessárias para minimizar estas interferências.

European Community (EC) directives conformity

This product is in conformity with the protection requirements of EC Council directives 2014/30/EU, 2014/35/EU, and 2011/65/EU as amended by (EU) 2015/863 on the approximation and harmonization of the laws of the Member States relating to electromagnetic compatibility, safety of electrical equipment designed for use within certain voltage limits, and on the restrictions of use of certain hazardous substances in electrical and electronic equipment.

The manufacturer of this product is: Lexmark International, Inc., 740 West New Circle Road, Lexington, KY, 40550 USA. The EEA/EU authorized representative is: Lexmark International Technology Hungária Kft., 8 Lechner Ödön fasor, Millennium Tower III, 1095 Budapest HUNGARY. The EEA/EU Importer is: Lexmark International Technology S.à.r.l. 20, Route de Pré-Bois, ICC Building, Bloc A, CH-1215 Genève, Switzerland. A declaration of conformity to the requirements of the Directives is available upon request from the Authorized Representative or may be obtained at www.lexmark.com/en_us/about/regulatory-compliance/european-union-declaration-of-conformity.html.

This product satisfies the Class A limits of EN 55032 and safety requirements of EN 62368-1.

United Kingdom (UK) conformity

This product is in conformity with the protection requirements of the Electromagnetic Compatibility Regulations 2016, the Electrical Equipment (Safety) Regulations 2016, and the Restriction of the Use of Certain Hazardous Substances in Electrical and Electronic Equipment Regulations 2012.

The manufacturer of this product is: Lexmark International, Inc., 740 West New Circle Road, Lexington, KY, 40550 USA. The UK Importer is: Lexmark International Ltd, Highfield House, Foundation Park - 8 Roxborough Way, Maidenhead Berkshire - SL6 3UD, United Kingdom. A declaration of conformity is available upon request from the UK Importer or may be obtained at www.lexmark.com/en_us/about/regulatory-compliance/uk-declaration-of-conformity.html.

This product satisfies the Class A limits of BS EN 55032 and safety requirements of BS EN 62368-1.

Radio interference notice

Warning

This is a product that complies with the emission requirements of EN 55032 Class A limits and immunity requirements of EN 55035. This product is not intended to be used in residential/domestic environments.

This is a Class A product. In a domestic environment, this product may cause radio interference, in which case the user may be required to take adequate measures.

STATEMENT OF LIMITED WARRANTY FOR LEXMARK LASER PRINTERS, LEXMARK LED PRINTERS, AND LEXMARK MULTIFUNCTION LASER PRINTERS

Lexmark International, Inc., Lexington, KY

This limited warranty applies to the United States and Canada. For customers outside the U.S., refer to the country-specific warranty information that came with your product.

This limited warranty applies to this product only if it was originally purchased for your use, and not for resale, from Lexmark or a Lexmark Remarketer, referred to in this statement as “Remarketer.”

Limited warranty

Lexmark warrants that this product:

- Is manufactured from new parts, or new and serviceable used parts, which perform like new parts
- Is, during normal use, free from defects in material and workmanship

If this product does not function as warranted during the warranty period, contact a Remarketer or Lexmark for repair or replacement (at Lexmark's option).

If this product is a feature or option, this statement applies only when that feature or option is used with the product for which it was intended. To obtain warranty service, you may be required to present the feature or option with the product.

If you transfer this product to another user, warranty service under the terms of this statement is available to that user for the remainder of the warranty period. You should transfer proof of original purchase and this statement to that user.

Limited warranty service

The warranty period starts on the date of original purchase as shown on the purchase receipt and ends 12 months later provided that the warranty period for any supplies and for any maintenance items included with the printer shall end earlier if it, or its original contents, are substantially used up, depleted, or consumed. Fuser Units, Transfer/Transport Units, Paper Feed items, if any, and any other items for which a Maintenance Kit is available are substantially consumed when the printer displays a “Life Warning” or “Scheduled Maintenance” message for such item.

To obtain warranty service you may be required to present proof of original purchase. You may be required to deliver your product to the Remarketer or Lexmark, or ship it prepaid and suitably packaged to a Lexmark designated location. You are responsible for loss of, or damage to, a product in transit to the Remarketer or the Lexmark designated location.

When warranty service involves the exchange of a product or part, the item replaced becomes the property of the Remarketer or Lexmark. The replacement may be a new or repaired item.

The replacement item assumes the remaining warranty period of the original product.

Replacement is not available to you if the product you present for exchange is defaced, altered, in need of a repair not included in warranty service, damaged beyond repair, or if the product is not free of all legal obligations, restrictions, liens, and encumbrances.

As part of your warranty service and/or replacement, Lexmark may update the firmware in your printer to the latest version. Firmware updates may modify printer settings and cause counterfeit and/or unauthorized products, supplies, parts, materials (such as toners and inks), software, or interfaces to stop working. Authorized use of genuine Lexmark products will not be impacted.

Before you present this product for warranty service, remove all print cartridges, programs, data, and removable storage media (unless directed otherwise by Lexmark).

For further explanation of your warranty alternatives and the nearest Lexmark authorized servicer in your area contact Lexmark on the World Wide Web.

Remote technical support is provided for this product throughout its warranty period. For products no longer covered by a Lexmark warranty, technical support may not be available or only be available for a fee.

Extent of limited warranty

Lexmark does not warrant uninterrupted or error-free operation of any product or the durability or longevity of prints produced by any product.

Warranty service does not include repair of failures caused by:

- Modification or unauthorized attachments
- Accidents, misuse, abuse or use inconsistent with Lexmark user's guides, manuals, instructions or guidance
- Unsuitable physical or operating environment
- Maintenance by anyone other than Lexmark or a Lexmark authorized servicer
- Operation of a product beyond the limit of its duty cycle
- Use of printing media outside of Lexmark specifications
- Refurbishment, repair, refilling or remanufacture by a third party of products, supplies or parts
- Products, supplies, parts, materials (such as toners and inks), software, or interfaces not furnished by Lexmark

TO THE EXTENT PERMITTED BY APPLICABLE LAW, NEITHER LEXMARK NOR ITS THIRD PARTY SUPPLIERS OR REMARKETERS MAKE ANY OTHER WARRANTY OR CONDITION OF ANY KIND, WHETHER EXPRESS OR IMPLIED, WITH RESPECT TO THIS PRODUCT, AND SPECIFICALLY DISCLAIM THE IMPLIED WARRANTIES OR CONDITIONS OF MERCHANTABILITY, FITNESS FOR A PARTICULAR PURPOSE, AND SATISFACTORY QUALITY. ANY WARRANTIES THAT MAY NOT BE DISCLAIMED UNDER APPLICABLE LAW ARE LIMITED IN DURATION TO THE WARRANTY PERIOD. NO WARRANTIES, EXPRESS OR IMPLIED, WILL APPLY AFTER THIS PERIOD. ALL INFORMATION, SPECIFICATIONS, PRICES, AND SERVICES ARE SUBJECT TO CHANGE AT ANY TIME WITHOUT NOTICE.

Limitation of liability

Your sole remedy under this limited warranty is set forth in this document. For any claim concerning performance or nonperformance of Lexmark or a Remarketer for this product under this limited warranty, you may recover actual damages up to the limit set forth in the following paragraph.

Lexmark's liability for actual damages from any cause whatsoever will be limited to the amount you paid for the product that caused the damages. This limitation of liability will not apply to claims by you for bodily injury or damage to real property or tangible personal property for which Lexmark is legally liable. **IN NO EVENT WILL LEXMARK BE LIABLE FOR ANY LOST PROFITS, LOST SAVINGS, INCIDENTAL DAMAGE, OR OTHER ECONOMIC OR CONSEQUENTIAL DAMAGES.** This is true even if you advise Lexmark or a Remarketer of the possibility of such damages. Lexmark is not liable for any claim by you based on a third party claim.

This limitation of remedies also applies to claims against any Suppliers and Remarketers of Lexmark. Lexmark's and its Suppliers' and Remarketers' limitations of remedies are not cumulative. Such Suppliers and Remarketers are intended beneficiaries of this limitation.

Additional rights

Some states do not allow limitations on how long an implied warranty lasts, or do not allow the exclusion or limitation of incidental or consequential damages, so the limitations or exclusions contained above may not apply to you.

This limited warranty gives you specific legal rights. You may also have other rights that vary from state to state.

Index

Numerics

- 2 x 520-sheet tray
 - installing 69
- 2000-sheet tandem tray
 - loading 45
- 2000-sheet tandem tray
 - installing 76
- 2000-sheet tandem tray roller kit
 - cleaning 313
 - replacing 258
- 2000-sheet tray
 - installing 83
- 2000-sheet tray feed rollers
 - cleaning 309
- 2000-sheet tray roller kit
 - replacing 254
- 2520-sheet tandem tray
 - loading 49
- 520-sheet tray
 - loading 42
- 520-sheet tray insert
 - replacing 236

A

- activating Voice Guidance 39
- adding apps to home screen 35
- adding contact groups 38
- adding contacts 38
- adding hardware options
 - print driver 61
- adding internal options
 - print driver 61
- adding printers to a computer 59
- Address Book
 - using 38
- adjusting brightness
 - of display 322
- adjusting default volume
 - headphone 41
 - speaker 41
- adjusting speech rate
 - Voice Guidance 41
- adjusting toner darkness 174
- AirPrint
 - using 168
- attaching cables 34
- avoiding paper jams 358

B

- B4 paper guide
 - replacing 280
- banner tray
 - installing 88
- black images 342
- blank pages 331
- booklet
 - printing 169
- booklet finisher
 - using 169
- bookmarks
 - creating 37
 - creating folders for 38

C

- canceling a print job 174
- cannot connect printer to Wi-Fi 392
- cannot open Embedded Web Server 391
- changing the printer port settings after installing ISP 159
- changing the wallpaper 36
- checking the status of parts and supplies 222
- cleaning
 - exterior of the printer 304
 - interior of the printer 304
- cleaning parts
 - 2000-sheet tandem tray roller kit 313
- cleaning pick rollers 313
- cleaning the 2000-sheet tray feed rollers 309
- cleaning the printer 304
- cleaning the touch screen 304
- cleaning the tray roller kit 305
- clearing jam
 - in door A 367
 - in door B 362
 - in optional trays 362
 - in staple finisher 371
 - in staple, hole punch finisher 373
 - in the 2000-sheet tandem tray 362
 - in the 2000-sheet tray 366
 - in the 520-sheet tray 362
 - in the booklet finisher 385
 - in the standard bin 370
 - in the standard tray 361
- clearing jams
 - in multipurpose feeder 366
 - in the trifold/Z-fold finisher 375
- collated printing does not work 397
- color correction 399
- color quality, troubleshooting
 - print appears tinted 400
- colored background on print 334
- computer
 - connecting to the printer 162
- confidential documents do not print 352
- confidential print jobs
 - configuring 171
 - printing 171
- configuring supply notifications 222
- configuring Wi-Fi Direct 161
- connecting a computer to the printer 162
- connecting mobile device to printer 162
- connecting the printer to a wireless network 160
- connecting to a wireless network using PIN method 160
- using Push Button method 160
- conserving supplies 323
- contacting customer support 401
- control panel
 - using 12
- controller board access cover
 - replacing 288
- creating bookmarks 37
- creating folders
 - for bookmarks 38
- crooked print 341
- Customer Support
 - using 37
- customer support
 - contacting 401
- customizing the display 36

D

- dark print 332
- deactivating the Wi-Fi network 163
- deactivating Voice Guidance 39
- default headphone volume
 - adjusting 41
- default speaker volume
 - adjusting 41
- defective intelligent storage drive 395
- deleting contact groups 38
- deleting contacts 38
- Device Quotas
 - setting up 37
- directory list
 - printing 172
- display brightness
 - adjusting 322
- Display Customization
 - using 36
- displaying apps on home screen 35
- documents, printing
 - from a computer 167
 - from a mobile device 167
- dots on printed page 339
- dual catch bin
 - installing 93
 - replacing 287

E

- editing contacts 38
- emission notices 404
- emptying the hole punch box 320
- enabling Magnification mode 40
- enabling personal identification numbers 41
- enabling spoken passwords 41
- enabling the USB port 357
- enabling Wi-Fi Direct 162
- envelope seals when printing 396
- envelope tray
 - installing 61
 - loading 53
- environmental settings 322
- erasing
 - printer memory 164
 - printer memory 165

- erasing printer storage drive 165
- error codes 325
- error messages 325
- Ethernet cable 34
- Ethernet port 34
- exporting a configuration file
 - using the Embedded Web Server 60
- e-mail alerts
 - setting up 222

F

- factory default settings
 - restoring 165
- FAQ about color printing 399
- file types
 - supported 170
- finding printer information 8
- finding the printer serial number 9
- firmware, updating 60
- flash drive
 - printing from 169
- flash drives
 - supported 170
- folding printed sheets 173
- font sample list
 - printing 172
- fuser
 - replacing 238

G

- genuine Lexmark parts and supplies 223
- genuine parts and supplies 223
- ghost images 333
- gray background on print 334

H

- hard disk
 - erasing 165
- hard disk storage drive 165
- hardware options
 - 2 x 520-sheet tray 69
 - 2000-sheet tandem tray 76
 - 2000-sheet tray 83
 - banner tray 88
 - booklet finisher 111
 - envelope tray 61
 - spacer 63
 - staple finisher 94

- hardware options, adding
 - print driver 61
- held documents do not print 352
- held jobs
 - printing 171
 - setting expiration time 171
- Hibernate mode
 - configuring 322
- hole punch box
 - emptying 320
 - replacing 281
- home screen
 - customizing 35
 - using 35
- home screen icons
 - displaying 35
- horizontal dark lines 345
- horizontal white lines 347
- humidity around the printer 407

I

- icons on the home screen
 - showing 35
- identifying jam locations 359
- images cut off on print 343
- importing a configuration file
 - using the Embedded Web Server 60
- incorrect margins 335
- indicator light
 - understanding the status 12
- installing
 - booklet finisher 111
 - staple finisher 101
- installing 2 x 520-sheet tray 69
- installing 2000-sheet tandem tray 76
- installing 2000-sheet tray 83
- installing internal options
 - intelligent storage drive 146
- installing optional spacer 63
- installing options
 - internal solutions port 152
 - printer hard disk 140
- installing the banner tray 88
- installing the booklet finisher 111
- installing the dual catch bin 93
- installing the envelope tray 61
- installing the print driver 58
- installing the printer software 58
- installing the staple finisher 94

- installing the staple, hole punch finisher 101
- installing trifold/Z-fold finisher 125
- installing wireless print server 150
- intelligent storage drive 165
 - erasing 165
 - installing 146
- internal option is not detected 393
- internal options, adding print driver 61
- internal solutions port
 - installing 152
 - troubleshooting 394

J

- jammed pages are not reprinted 398
- jams, paper
 - avoiding 358
- job prints from the wrong tray 353
- job prints on the wrong paper 353

L

- letterhead
 - selecting 15
- Lexmark Mobile Print
 - using 167
- Lexmark Print
 - using 167
- light print 336
- linking trays 58
- loading 2000-sheet tandem tray 45
- loading 2520-sheet tandem tray 49
- loading 520-sheet tray 42
- loading envelope tray 53
- loading letterhead 55
- loading multipurpose feeder 55
- loading prepunched paper 55
- loading trays 42, 45
- locating jam areas 359
- locating the security slot 164
- lower rear connector cover
 - replacing 270

M

- Magnification mode
 - enabling 40
- managing screen saver 36
- manual color correction 399
- MarkNet N8372 Wireless Print Server 150
- menu
 - 802.1x 209
 - About this Printer 186
 - Accessibility 181
 - AirPrint 203
 - Anonymous Data
 - Collection 180
 - Cloud Services Enrollment 219
 - Confidential Print Setup 217
 - Configuration Menu 182
 - Device 220
 - Disk Encryption 218
 - Eco-Mode 177
 - Erase Temporary Data Files 218
 - Ethernet 205
 - Finishing 188
 - Flash Drive Print 198
 - Home Screen
 - Customization 186
 - HTTP/FTP Settings 211
 - Image 195
 - IPSec 208
 - Job Accounting 191
 - Layout 186
 - Local Accounts 214
 - Login Restrictions 217
 - LPD Configuration 210
 - Manage Permissions 213
 - Media Types 197
 - Menu Settings Page 220
 - Miscellaneous 219
 - Mobile Services
 - Management 204
 - Network 221
 - Network Overview 200
 - Notifications 178
 - Out of Service Erase 185
 - PCL 193
 - PDF 192
 - PostScript 193
 - Power Management 179
 - Preferences 176
 - Print 220
 - Quality 190

- Remote Operator Panel 177
- Restore Factory Defaults 182
- Restrict external network
 - access 212
- Schedule USB Devices 214
- Security Audit Log 214
- Setup 189
- SNMP 207
- Solutions LDAP Settings 218
- TCP/IP 206
- ThinPrint 211
- Tray Configuration 196
- Troubleshooting 221
- Universal Setup 196
- USB 212
 - Wireless 200
 - Wi-Fi Direct 203
- Menu Settings Page
 - printing 221
- missing colors 338
- missing or unresponsive toner cartridge 395
- mobile device
 - connecting to printer 162
 - printing from 167, 168
- modifying color output 399
- Mopria Print Service 168
- mottled print and dots 339
- moving the printer 33, 323
- Multiple Universal Sizes
 - enabling 42
- multipurpose feeder
 - loading 55

N

- navigating the screen
 - using gestures 39
- navigating the screen using gestures 39
- network setup page
 - printing 163
- noise emission levels 404
- nonvolatile memory
 - erasing 164
- Non-Lexmark supply 395
- non-volatile memory 165
- Not enough free space in flash memory for resources 395
- notices 404, 406, 407, 408

O

- offset stacking in printed sheets 174
- on-screen keyboard
 - using 40
- optional spacer
 - installing 63
- ordering supplies
 - photoconductor unit 224
 - toner cartridge 223
 - waste toner bottle 224

P

- paper
 - letterhead 15
 - preprinted forms 15
 - selecting 13
 - unacceptable 14
 - Universal size setting 41
- paper bail
 - replacing 285
- paper characteristics 13
- paper frequently jams 398
- paper guidelines 13
- paper jam
 - in door A 367
 - in multipurpose feeder 366
 - in staple finisher 371
 - in staple, hole punch finisher 373
 - in the 2000-sheet tray 366
 - in the booklet finisher 385
 - in the standard tray 361
 - in the trifold/Z-fold finisher 375
- paper jam in door B 362
- paper jam in optional trays 362
- paper jam in the 2000-sheet tandem tray 362
- paper jam in the 520-sheet tray 362
- paper jam in the standard bin 370
- paper jams
 - avoiding 358
 - location 359
- paper size
 - setting 41
- paper sizes
 - supported 15
- paper type
 - setting 41
- paper types
 - supported 28
- paper weights
 - supported 32
- parallel interface card
 - troubleshooting 394
- parts status
 - checking 222
- personal identification number method 160
- personal identification numbers
 - enabling 41
- photoconductor unit
 - ordering 224
 - replacing 229
- placing separator sheets 172
- power cord socket 34
- power save modes
 - configuring 322
- preprinted forms
 - selecting 15
- print appears tinted 400
- print driver
 - hardware options, adding 61
 - installing 58
- print job
 - canceling 174
- print jobs not printed 351
- Print Quality Test Pages 221
- print quality troubleshooting
 - black pages 331
 - crooked print 341
 - dark print 332
 - ghost images appear on prints 333
 - gray or colored background 334
 - horizontal dark lines 345
 - horizontal white lines 347
 - light print 336
 - missing colors 338
 - mottled print and dots 339
 - paper curl 340
 - repeating print defects 350
 - skewed print 341
 - solid color or black images 342
 - text or images cut off 343
 - toner easily rubs off 344
 - uneven print density 344
 - vertical dark lines appear on prints 346
 - vertical white lines 349
- white pages 331
- print troubleshooting
 - collated printing does not work 397
 - confidential and other held documents do not print 352
 - envelope seals when printing 396
 - incorrect margins 335
 - job prints from the wrong tray 353
 - job prints on the wrong paper 353
 - paper frequently jams 398
 - print jobs do not print 351
 - slow printing 354
 - tray linking does not work 397
 - unable to read flash drive 357
- printed sheets
 - offset stacking 174
 - punching holes 173
 - stapling 172
- printed sheets, folding 173
- printer
 - minimum clearances 33
 - selecting a location for 33
 - shipping 323
- printer configurations 10
- printer error codes 325
- printer error messages 325
- printer hard disk
 - installing 140
- printer information
 - finding 8
- printer is not responding 356
- printer memory
 - erasing 164
- printer menus 175, 221
- printer messages
 - Defective flash detected 395
 - Non-Lexmark supply 395
 - Not enough free space in flash memory for resources 395
- printer options troubleshooting
 - cannot detect internal option 393
 - internal solutions port 394
 - parallel interface card 394
 - serial interface card 394
- printer port settings
 - changing 159
- printer ports 34

- printer settings
 - restoring factory default 165
- printer software
 - installing 58
- printer status 12
- printhead wiper
 - replacing 242
- printing
 - confidential print jobs 171
 - directory list 172
 - font sample list 172
 - from a computer 167
 - from a flash drive 169
 - from a mobile device 168
 - held jobs 171
 - Menu Settings Page 221
 - network setup page 163
 - using Mopria Print Service 168
 - using Wi-Fi Direct 168
- printing a booklet 169
- printing a directory list 172
- printing a font sample list 172
- printing a network setup page 163
- printing from a computer 167
- punching holes in printed sheets 173
- Push Button method 160

R

- R9 rear cover
 - replacing 292
- rear ports cover
 - replacing 291
- recycling
 - Lexmark packaging 402
 - Lexmark products 402
- removing paper jam
 - in door A 367
 - in door B 362
 - in optional trays 362
 - in staple finisher 371
 - in staple, hole punch finisher 373
 - in the 2000-sheet tandem tray 362
 - in the 2000-sheet tray 366
 - in the 520-sheet tray 362
 - in the booklet finisher 385
 - in the standard bin 370
 - in the standard tray 361
 - in the trifold/Z-fold finisher 375

- removing paper jam, clearing
 - in multipurpose feeder 366
- repeat print jobs 171
- repeating print defects 350
- replacing parts
 - 2000-sheet tandem tray roller kit 258
 - 2000-sheet tray roller kit 254
 - 520-sheet tray insert 236
 - B4 paper guide 280
 - controller board access cover 288
 - dual catch bin 287
 - fuser 238
 - lower rear connector cover 270
 - paper bail 285
 - printhead wiper 242
 - R9 rear cover 292
 - rear ports cover 291
 - second transfer roller 267
 - small cover 278
 - staple cartridge holder 298, 301
 - transfer module cleaner 245
 - tray roller kit 250
 - trifold/Z-fold finisher bin 283
 - waste toner transfer unit 275
- replacing pick rollers 258
- replacing supplies
 - hole punch box 281
 - photoconductor unit 229
 - staple cartridge 293, 296
 - toner cartridge 224
 - waste toner bottle 271
- replacing the waste toner bottle 271
- reports
 - printer status 223
 - printer usage 223
- resetting
 - supply usage counters 395
- resetting supply usage counters 303
- resetting the supply usage counters 395
- running a slideshow 36

S

- safety information 5, 6, 7
- second transfer roller
 - replacing 267
- securing printer data 165

- security slot
 - locating 164
- selecting location
 - for the printer 33
- separator sheets
 - placing 172
- serial interface card
 - troubleshooting 394
- serial number, printer
 - finding 9
- serial printing
 - setting up 163
- setting paper size
 - Multiple Universal Sizes 42
- setting the paper size 41
- setting the paper type 41
- setting the Universal paper size 41
- setting up Device Quotas 37
- setting up e-mail alerts 222
- setting up serial printing 163
- shipping the printer 323
- skewed print 341
- Sleep mode
 - configuring 322
- slow printing 354
- small cover
 - replacing 278
- solid color 342
- spoken passwords
 - enabling 41
- staple cartridge
 - replacing 293, 296
- staple cartridge holder
 - replacing 298, 301
- staple finisher
 - installing 94
- stapling printed sheets 172
- statement of volatility 165
- storage drive
 - erasing 165
- storing paper 14
- storing print jobs 171
- supplies
 - conserving 323
 - status
 - checking 222
 - troubleshooting
 - missing or unresponsive toner cartridge 395
 - notifications
 - configuring 222

- supply usage counters
 - resetting 303, 395
- supported applications 36
- supported file types 170
- supported flash drives 170
- supported paper sizes 15
- supported paper types 28
- supported paper weights 32

T

- temperature around the printer 407
- text cut off on print 343
- toner cartridge
 - ordering 223
 - replacing 224
- toner darkness
 - adjusting 174
- toner easily rubs off 344
- touch screen
 - cleaning 304
- transfer module cleaner
 - replacing 245
- tray roller kit
 - cleaning 305
 - replacing 250
- trays
 - linking 58
 - unlinking 58
- trifold/Z-fold finisher
 - installing 125
- trifold/Z-fold finisher bin
 - replacing 283
- troubleshooting
 - cannot connect printer to Wi-Fi 392
 - cannot open Embedded Web Server 391
 - FAQ about color printing 399
 - printer is not responding 356
- troubleshooting, color quality
 - print appears tinted 400
- troubleshooting, print
 - collated printing does not work 397
 - confidential and other held documents do not print 352
 - envelope seals when printing 396
 - incorrect margins 335
 - jammed pages are not reprinted 398

- job prints from the wrong tray 353
- job prints on the wrong paper 353
- paper frequently jams 398
- print jobs do not print 351
- slow printing 354
- tray linking does not work 397

troubleshooting, print quality

- blank pages 331
- crooked print 341
- dark print 332
- ghost images appear on prints 333
- gray or colored background 334
- horizontal dark lines 345
- horizontal white lines 347
- light print 336
- missing colors 338
- mottled print and dots 339
- paper curl 340
- repeating print defects 350
- skewed print 341
- solid color or black images 342
- text or images cut off 343
- toner easily rubs off 344
- uneven print density 344
- vertical dark lines appear on prints 346
- vertical white lines 349
- white pages 331

troubleshooting, printer options

- cannot detect internal option 393
- internal solutions port 394

troubleshooting, supplies

- missing or unresponsive toner cartridge 395

U

- unable to read flash drive
 - troubleshooting, print 357
- uneven print density 344
- Universal paper size
 - setting 41
- unlinking trays 58
- updating firmware 60
- USB cable 34
- USB port 34
 - enabling 357
- using Customer Support 37

- using Display Customization 36
- using genuine Lexmark parts and supplies 223
- using the control panel 12
- using the home screen 35

V

- verify print jobs 171
- vertical dark lines appear on prints 346
- vertical white lines 349
- viewing reports 223
- Voice Guidance
 - activating 39
 - deactivating 39
 - speech rate 41
- Voice Guidance speech rate
 - adjusting 41
- volatile memory 165
 - erasing 164

W

- waste toner bottle
 - ordering 224
 - replacing 271
- waste toner transfer unit
 - replacing 275
- white pages 331
- wireless network
 - connecting the printer to 160
 - Wi-Fi Protected Setup 160
- wireless networking 160
- wireless print server
 - installing 150
- Wi-Fi Direct
 - configuring 161
 - enabling 162
 - printing from a mobile device 168
- Wi-Fi network
 - deactivating 163
- Wi-Fi Protected Setup
 - wireless network 160