

Technical Datasheet

AFBR-5971ALZ-C

Avago Broadcom® Compatible 2x5 SFF 155Mbps Transceiver

+3.3V, LC, Single-Mode, 1310nm, 20km, Industrial Temperature

FEATURES

- 2x5 Pin Package, Single-Mode Transceiver
- RoHS Compliant, Lead Free
- FP Laser Diode Transmitter
- 3.3V power supply
- Up to 20km on 9/125µm SMF
- LC duplex optical interface
- (LV)PECL/CML Differential Inputs /Outputs and (LV)PECL or (LV)TTL signal detect
- Class 1 Laser International Safety Standard IEC 825 Compliant
- Industrial Operating Temperature Range: -40°C to 85°C

APPLICATIONS

- ATM 155Mbps
- SONET/SDH
- 100Mbps Ethernet Equipment
- Other Optic Link

DESCRIPTION

ATGBICS AFCT-5971ALZ-C transceiver is a high performance, cost effective transceiver modules are the perfect solution for low -speed communication networks. It supports data rates up to 200Mbps. The module is fully compliant with the 2X5 standard package defined by the Small Form Factor Multi-Sourcing Agreement (MSA). It provides the system designer with products to implement a range of SONET/OC-3, SDH/STM-1 for Telecommunication.

Technical Datasheet

Absolute Maximum Ratings

Parameter	Symbol	Min	Max	Units	Note
Storage Temperature	TST	-40	+85	°C	-
Relative Humidity	RH	5	95	%	-
Supply Voltage	VCC	0	+3.6	V	-

Recommended Operating Environment and Electrical Characteristics

Parameter	Symbol	Min	Typ	Max	Units	Note
Supply Voltage	VCC	+3.1	+3.3	+3.5	V	-
Supply Current	Icc	-	-	260	mA	-
Operating Case Temperature	TOP	0	-	+70	°C	1
		-40	-	+85		2
Data Rate	B	10	155	200	Mbps	-
Soldering temperature	-	-	-	260	°C	3
Soldering duration	-	-	-	10	Sec	3

Notes:

1. Standard level
2. Industrial level
3. Not recommended wave soldering

Technical Datasheet

Optical Parameters

Transceiver Optical Characteristics (Ambient Operating Temperature $T_a = +25 \pm 5^\circ\text{C}$, $V_{CC} = 3.3 \pm 0.2\text{V}$)

Parameter	Symbol	Min	Typ	Max	Units	Notes
Transmitter	-	-	-	-	-	-
Data rate	B	10	155	200	Mbps	-
Output Center Wavelength	λ_C	1260	1310	1360	nm	-
Output Spectral width (RMS)	λ	-	-	4.0	nm	-
Average Optical Output Power	P_o	-14	-	-5	dBm	1,2
Extinction Ratio	ER	10	-	-	dB	-
Optic Output Eye: Compliant ITU-T G.957	-	-	-	-	-	1,2
Receiver	-	-	-	-	-	-
Receiver Sensity	S	-	-	-32	dB	1,2
Maximum Input Power	P _{MAX}	-3	-	-	dBm	1,2
Operation Center Wavelength	λ_c	1200	-	1600	nm	-
Signal Detect	Deassert	PD	-45	-	dBm	1,2
Signal Detect	Assert	PA	-	-32	dBm	1,2
Signal Detect--Hysteresis	PHYS	0.5	-	-	dB	-

Notes:

1. The optical power is launched into 9/125 μm SMF.
2. With a PRBS 223-1 test pattern@ 155Mbps.

Technical Datasheet

Electrical Parameters

Transceiver Electrical Characteristics (Ambient Operating Temperature $T_a = +25 \pm 5^\circ\text{C}$, $V_{CC} = 3.3 \pm 0.2\text{V}$)

Parameter	Symbol	Min	Typ	Max	Units	Notes
Supply Voltage	VCC	+3.1	+3.3	+3.5	V	-
Supply Current	ICC	-	-	260	mA	-
Transmitter						
Differential Input Voltage	V _{in}	400	-	2000	mVP-P	-
Input Differential Impedance	Z _{in}	90	100	110	Ω	-
Data Input Voltage - Low	V _{IL}	VCC 1.81	-	VCC 1.48	V	-
Data Input Voltage - High	V _{IH}	VCC 1.17	-	VCC 0.88	V	-
Receiver						
Differential Output Voltage	V _{OUT}	400	-	2000	mVP-P	-
Data Output Voltage – Low	V _{OL}	VCC 1.83	-	VCC 1.56	V	-
Data Output Voltage – High	V _{OH}	VCC 1.09	-	VCC 0.88	V	-
SD Output Voltage-Low	V _{OL}	VCC 2.0	-	VCC 1.56	V	1
SD Output Voltage-High	V _{OH}	VCC 1.1	-	VCC 0.75	V	1
SD Output Voltage-Low	V _{OL}	0	-	0.8	V	2
SD Output Voltage-High	V _{OH}	2	-	VCC	V	2

Notes:

1. (LV)PECL signal detect;
2. (LV)TTL signal detect;

Technical Datasheet

Pin Definitions

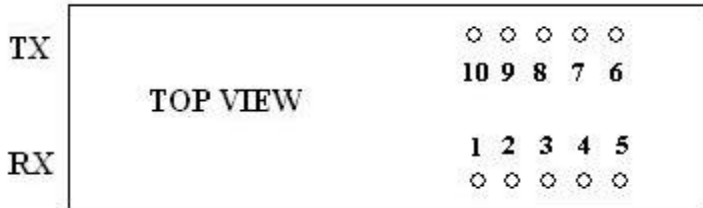

Pin Function Definitions

Pin #	Pin Name	Description	Notes
1	VEER	Receiver Ground	-
2	VCCR	Receiver Power Supply	-
3	SD	Signal Detect. (LV)PECL or (LV)TTL output	1
4	RD-	Inv. Received Data Out	-
5	RD+	Received Data Out	-
6	VCCT	Transmitter Power Supply	-
7	VEET	Transmitter Ground	-
8	TDIS	Transmitter Disable	2
9	TD+	Transmit Data In	-
10	TD-	Inv. Transmit Data In	-

Notes:

1. (LV)PECL-Normal optical input levels to the receiver result in logic “1” output, pull-down 130Ω or 270Ω resistor; (LV)TTL-Normal optical input levels to the receiver result in logic “0” output, pull-up 10kΩ resistor.
2. This is an input that is used to shut down the transmitter optical output. Transmitter on in logic “0”.

Technical Datasheet

Recommended Circuit

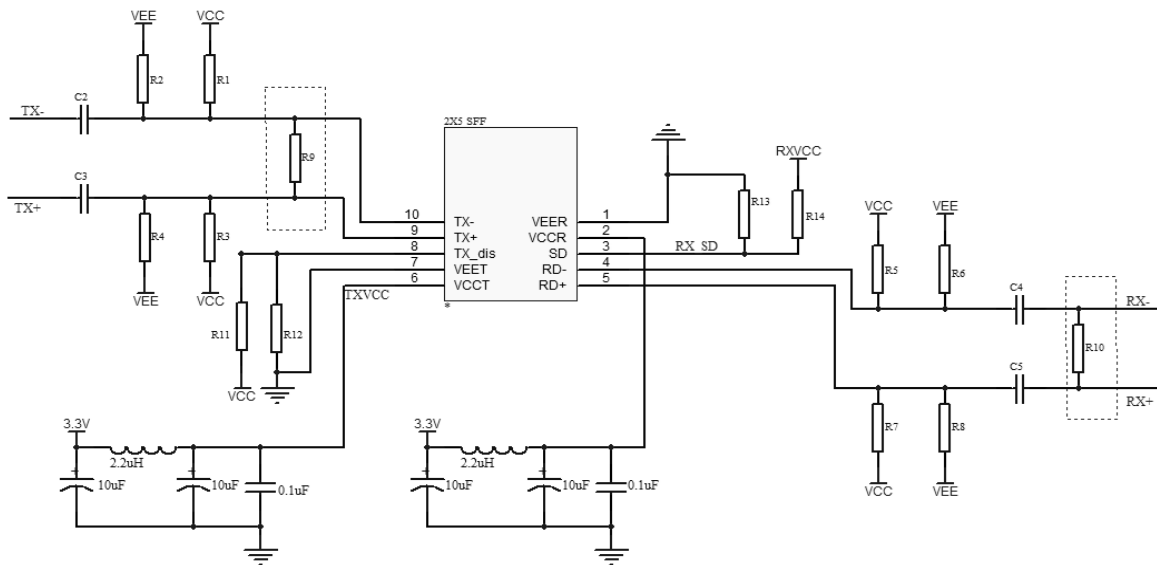

$R1=R3=R5=R7=130\Omega$, $R2=R4=R6=R8=82\Omega$, $C2=C3=C4=C5=104p$, $R5=R10=100\Omega=NC$,
 $R11=R12=10K$,

$SD=LVPECL$: $R14=10K=NC$, $R13=130\Omega$, $SD=LVTTTL$: $R14=10K$, $R12=130\Omega=NC$.

Technical Datasheet

Mechanical Dimensions (units: mm)

