

S3048-ON Installation Guide

January 2019

Notes, Cautions, and Warnings

 **NOTE:** A NOTE indicates important information that helps you make better use of your computer.

 **CAUTION:** A CAUTION indicates either potential damage to hardware or loss of data and tells you how to avoid the problem.

 **WARNING:** A WARNING indicates a potential for property damage, personal injury, or death.

© 2014 - 2019 Dell Inc. or its subsidiaries. All rights reserved. Dell, EMC, and other trademarks are trademarks of Dell Inc. or its subsidiaries. Other trademarks may be trademarks of their respective owners.

Contents

1 About this guide	5
Related documents.....	5
2 The S3048–ON switch	6
Introduction.....	6
Features.....	7
Physical dimensions.....	7
Switch status.....	7
LED display.....	7
LED behavior.....	8
Prerequisites.....	9
Switch configurations.....	10
3 Site preparations	11
Site selection.....	11
Cabinet placement.....	11
Rack mounting.....	12
Switch ground.....	12
Fans and airflow.....	12
Fan combinations.....	12
Power.....	12
Storing components.....	12
4 NEBS compliance	14
Important information.....	14
5 Install the S3048–ON	15
Unpack	15
Unpacking steps.....	15
Rack or cabinet hardware installation.....	16
Rack mount safety considerations.....	16
ReadyRails system installation.....	16
Switch installation.....	20
1U front-rack installation.....	20
Ground cable.....	22
Optics installation.....	22
Optics removal.....	22
Switch power-up.....	22
Power up sequence.....	23
6 Power supplies	24
Components.....	24

AC power supply installation.....	25
AC power supply replacement.....	26
7 Fans.....	27
Components.....	27
Fan module installation.....	28
Fan module replacement.....	28
After installing the switch.....	28
8 Management ports.....	29
RS-232 console port access.....	29
USB-B console port access.....	30
USB storage mount.....	30
Before you install an OS.....	31
Example of the Grub Bootloader.....	31
Example of ONIE.....	31
ONIE service discovery.....	32
9 Specifications.....	33
Chassis physical design.....	33
IEEE Standards.....	34
Agency compliance.....	34
USA Federal Communications Commission Statement.....	34
European Union EMC Directive Conformance Statement.....	35
Japan VCCI Compliance for Class A Equipment.....	35
Korean Certification of Compliance.....	36
Safety Standards and Compliance Agency Certifications.....	37
Electromagnetic compatibility	37
Emissions.....	37
Immunity.....	37
Product recycling and disposal.....	37
Waste Electrical and Electronic Equipment (WEEE) Directive for Recovery, Recycle and Reuse of IT and Telecommunications Products.....	38
10 Dell EMC support.....	39

About this guide

This guide provides site preparation recommendations, step-by-step procedures for rack mounting and desk mounting, inserting optional modules, and connecting to a power source.

⚠ **CAUTION:** To avoid electrostatic discharge (ESD) damage, wear grounding wrist straps when handling this equipment.

⚠ **WARNING:** Only trained and qualified personnel can install this equipment. Read this guide before you install and power up this equipment. This equipment contains two power cords. Disconnect both power cords before servicing.

⚠ **WARNING:** This equipment contains optical transceivers, which comply with the limits of Class 1 laser radiation.



Figure 1. Class 1 laser product tag

⚠ **WARNING:** When no cable is connected, visible and invisible laser radiation may be emitted from the aperture of the optical transceiver ports. Avoid exposure to laser radiation. Do not stare into open apertures.

Related documents

For more information about the S3048–ON switch, see the following documentation:

- *Dell Networking S3048–Open Networking (ON) Getting Started Guide*
- *Dell Networking S3048–Open Networking (ON) Release Notes*
- *Dell Open Networking Troubleshooting Guide*

ⓘ **NOTE:** For the most recent documentation, see the Dell EMC support: www.dell.com/support.

The S3048-ON switch

The following sections describe the Dell EMC S3048-ON switch.

Topics:

- [Introduction](#)
- [Features](#)
- [Physical dimensions](#)
- [Switch status](#)
- [LED display](#)
- [Prerequisites](#)
- [Switch configurations](#)

Introduction

The S3048-ON is a low-cost top-of-rack (ToR) switch for 1 Gbps links to servers and 10 Gbps uplinks to the 40 Gbps switching fabric in the core.

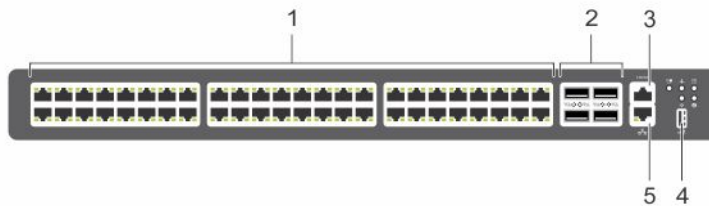

Figure 2. S3048-ON I/O-side view

- 1 Forty-eight 10/100/1000Base-T RJ-45 ports
- 2 Four SFP+ ports
- 3 Serial console port
- 4 USB 2.0 port
- 5 Management port



Figure 3. S3048-ON PSU-side view

- 1 Three fan modules
- 2 Two power supply units

Features

The S3048-ON offers the following features.

- Forty-eight 10/100/1000Base-T RJ-45 ports
- Four SFP+ 10G ports
- One serial console port
- One universal serial bus 2.0 (USB Type-A) port for additional file storage
- One management port
- Rangeley Central processing unit (CPU) system with 2GB DDR III RAM.
- Temperature monitoring
- Software-readable thermal monitor
- Real time clock (RTC) support
- Hot-plug redundant power supply
- Power management monitoring
- Removable fans
- Standard 1U chassis

Physical dimensions

The S3048-ON has the following physical dimensions:

- 434 x 320 x 44 mm (W x D x H)
- 17.09 x 12.60 x 1.73 inches (W x D x H)

Switch status

You can view S3048-ON status information using the LEDs.

LED display

The S3048-ON includes LED displays on the I/O side of the switch. This section describes open networking installation environment (ONIE) LED behaviors. Some LED behaviors may change after you install your software.

LED behavior

The following S3048-ON switch LED behavior is seen during ONIE operations:

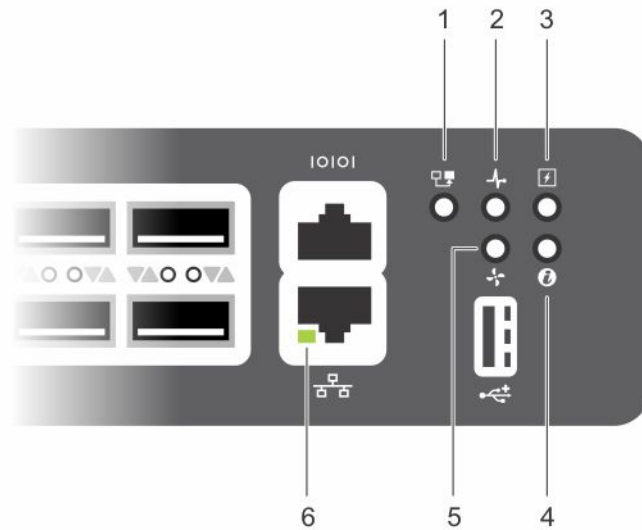

Figure 4. S3048-ON LEDs

- 1 System Status LED
- 2 Master LED
- 3 Power LED
- 4 Locator LED
- 5 Fan LED
- 6 Management Port LEDs

Table 1. S3048-ON LED behavior

LED	Description
System Status/Health LED	<ul style="list-style-type: none"> • Solid green—Normal operation • Blinking green—Booting • Solid yellow—Critical system error • Blinking yellow—Non-critical system error, fan failure, or power supply failure
Power LED	<ul style="list-style-type: none"> • Off—No power • Solid Green—Normal • Solid yellow—POST is in process • Blinking yellow—Power supply failed
Master LED	<ul style="list-style-type: none"> • Off—Switch is in Stacking Slave mode • Solid green—System is in Stacking Master or Standalone mode
FAN LED	<ul style="list-style-type: none"> • Solid green—Fan powered and running at the expected RPM

LED	Description
LOCATOR LED	<ul style="list-style-type: none"> • Solid yellow—Fan failed including incompatible airflow direction when you insert the PSU or fan trays with differing airflows • Off—Locator function is disabled • Blinking blue—Locator function is enabled

Table 2. Management Ethernet port LEDs

LED	Description
Link LED	<ul style="list-style-type: none"> • Off—No link • Solid green—Link on 1 Gbps speed • Solid yellow—Link on 10/100 Mbps speeds

Table 3. SFP+ Port LEDs

LED	Description
Link LED	<ul style="list-style-type: none"> • Off—No link • Solid green—Link on 10 Gbps speed • Flashing green, ~1 s—Link on less than 10 G speed
Activity LED	<ul style="list-style-type: none"> • Off—No link • Flashing green, ~30 ms—10 Gbps activity • Flashing green, ~1 s—Specific port locate

Prerequisites

The following is a list of components required for successful installation of the S3048-ON:

NOTE: Detailed installation instructions for the S3048-ON are provided in [Site Preparations](#) and [Install the S3048-ON](#).

- S3048-ON chassis or multiple chassis, if stacking
- AC country/regional-specific cables to connect the AC power source to each of the chassis' AC power supplies
- Mounting brackets for rack installation, included
- Screws for rack installation
- #1 and #2 Phillips screw drivers, not included
- Torx screwdriver, not included
- Ground cable screws, included
- Copper/fiber cables

Other optional components are:

- Ground cable
- Extra power supply unit
- Extra fan module
- Extra mounting brackets if installing in a four-post rack or cabinet

Switch configurations

You can order the S3048-ON switch in several different configurations.

You can order the following supported hardware components:

- S3048-ON AC Normal Airflow: Forty-eight 10/100/1000Base-T RJ-45 ports with four SFP+ 10 G ports, one AC power supply, and three fan subsystems—airflow from the I/O side to the power supply side
- S3048-ON AC Reverse Airflow: Forty-eight 10/100/1000Base-T RJ-45 ports with four SFP+ 10 G ports, one AC power supply, and three fan subsystems—airflow from the power supply side to the I/O side
- Fan with airflow from the I/O side to the PSU side
- Fan with airflow from the PSU side to the I/O side
- AC Power supply with airflow from the I/O side to the PSU side
- AC Power supply with airflow from the PSU side to the I/O side

Site preparations

The S3048–ON is suitable for installation as part of a common bond network (CBN).

You can install the switch in:

- Network telecommunication facilities
- Data centers
- Other locations where the National Electric Code (NEC) applies

For more information about S3048–ON specifications, see [Specifications](#).

ⓘ | NOTE: Install the S3048–ON switch into a rack or cabinet before installing any optional components.

Topics:

- [Site selection](#)
- [Cabinet placement](#)
- [Rack mounting](#)
- [Switch ground](#)
- [Fans and airflow](#)
- [Power](#)
- [Storing components](#)

Site selection

Install Dell EMC equipment in restricted access areas.

A restricted access area is one in which service personnel can only gain access using a special tool, lock, key or other means of security. Also, access is controlled by the authority responsible for the location.

Ensure that the area where you install your S3048–ON switch meets the following safety requirements:

- Near an adequate power source. Connect the switch to the appropriate branch circuit protection as defined by your local electrical codes.
- Environmental temperature range is from 32° to 113°F (from 0° to 45°C).
- The switch operating ambient temperature range is from 10° to 35°C (from 50° to 95°F).
- Operating humidity is from 5 to 85 percent noncondensing.
- Storage humidity is from 5 to 95 percent noncondensing.
- In a dry, clean, well-ventilated and temperature-controlled room, away from heat sources such as hot air vents or direct sunlight.
- Away from sources of severe electromagnetic noise.
- Positioned in a rack or cabinet, or on a desktop with adequate space in the front, rear, and sides for proper ventilation and access.

Cabinet placement

Install the S3048–ON only in indoor cabinets designed for use in a controlled environment.

Do not install the S3048–ON in outside cabinets. For cabinet placement requirements, see [Site Selection](#).

The cabinet must meet minimum size requirements. Airflow must be in accordance with the Electronic Industries Alliance (EIA) standard. Ensure that there is a minimum of 5 inches (12.7 cm) between the intake and exhaust vents and the cabinet wall.

Rack mounting

When you prepare your equipment rack, ensure that the rack is grounded.

Ground the equipment rack to the same ground point the power service in your area uses. The ground path must be permanent.

Switch ground

Dell EMC recommends you ground your switch. Use the S3048-ON in a common bond network (CBN).

Connect the grounding cables as described in [Install the S3048-ON](#).

Fans and airflow

The S3048-ON fans support two airflow options—normal and reverse.

Fan combinations

Installation of the fans is done as part of the factory install based on stock keeping units (SKU) type. The S3048-ON has SKUs that support the following configurations:

- AC PSU with fan airflow from the I/O to the PSU
- AC PSU with fan airflow from the PSU to the I/O

Be sure to order the fans suitable to support your site's ventilation. Use a single type of airflow fan in your switch. *Do not mix reverse and normal airflows in a single S3048-ON chassis.*

For proper ventilation, position the S3048-ON in an equipment rack or cabinet with a minimum of 5 inches (12.7 cm) of clearance around the exhaust vents. When you install two S3048-ON switch near each other, to permit proper airflow, position the two chassis at least 5 inches (12.7 cm) apart. The fan speed increases when the internal temperature reaches 161.6°F (72°C) and decreases to normal speed when the temperature falls to 136.4°F (58°C). The S3048-ON never intentionally turns off the fans.

Power

To connect the chassis to the applicable power source, use the appropriate power cord with the S3048-ON. An AC power cord is included with the switch.

When installing AC switches, follow the requirements of the National Electrical Code, ANSI/NFPA 70 where applicable.

The switch is powered-up as soon as the power cord is connected between the switch and the power source.

⚠ CAUTION: Always disconnect the power cable before you service the power supply slots.

⚠ CAUTION: Use the power supply cord as the main disconnect device on the AC switch. Ensure that the socket-outlet is located/installed near the equipment and is easily accessible.

Storing components

If you do not install your S3048-ON and components immediately, properly store the switch and all optional components by following these guidelines:

- Storage location temperature must remain constant. The storage range is from -40° to 158°F (-40°C to 70°C).

- Store on a dry surface or floor, away from direct sunlight, heat, and air conditioning ducts.
- Store in a dust-free environment.

① NOTE: ESD damage can occur when components are mishandled. Always wear an ESD-preventive wrist or heel ground strap when handling the S3048-ON and its accessories. After you remove the original packaging, place the S3048-ON and its components on an anti-static surface.

NEBS compliance

For your switch to be network equipment building system (NEBS) compliant, you must follow the instructions detailed in this section. To be NEBS compliant, orient your switch in the rack so that the air inlet is from the front aisle and the air exhaust is to the rear aisle.

Important information

⚠ WARNING: The form-factor pluggable plus (SFP+), 1000BASE-T, console, Ethernet management, and universal serial bus (USB) ports are suitable for connection to intrabuilding or unexposed wiring or cabling only. You **MUST NOT** metalically connect the ports to interfaces that connect to the out side plant (OSP) or its wiring. Use these interfaces as intrabuilding interfaces only (Type 2 or Type 4 ports as described in GR-1089-CORE, Issue 6) and they require isolation from the exposed OSP cabling. Adding primary protectors is not sufficient protection to connect these interfaces metalically to OSP wiring.

⚠ WARNING: If you install and connect the S3048-ON to a commercial AC power source, you must connect the switch to an external special protection device (SPD).

To be NEBs compliant, you must follow these regulations:

- Locate your switch in a restricted-access area were only trained personnel are allowed access.
- Install and connect your switch to the common bonding network (CBN).
- You can also install and connect your switch to the central office.
- Connect the battery returns of your switch as DC-I.
- Ground your switch using a copper ground conductor.
- Clean and coat all bare grounding connection points on your switch with an antioxidant solution before making connections.
- Bring all unplated surfaces on your switch to a bright finish and treat them with an antioxidant solution before making connections.
- Remove any nonconductive surfaces on your switch from the threads and connection points to ensure electrical continuity.
- Use the two-hole, Listed, compression-type lug with an AWG 14 gauge wire that uses 4-in/lb to secure your switch to the frame.

ⓘ NOTE: The S3048-ON can operate at -40.5 VDC to -60 VDC at a maximum current level of 24A.

ⓘ NOTE: The S3048-ON is Earthquake Z4-compliant when you attach the ReadyRails to the frame using threaded hardware.

Install the S3048–ON

To install the S3048–ON switch, complete the installation procedures in the order presented in this chapter.

Always handle the S3048–ON and its components with care. Avoid dropping the switch or its field replaceable units (FRUs).

This chapter describes the installation procedures as follows:

- 1 [Unpack](#)
- 2 [Rack or cabinet hardware installation](#)
- 3 [Switch installation](#)
- 4 [Optics installation](#)
- 5 [Power up the switch](#)

NOTE: ESD damage can occur if components are mishandled. Always wear an ESD-preventive wrist or heel ground strap when handling the S3048–ON and its components. As with all electrical devices of this type, take all the necessary safety precautions to prevent injury when installing this switch.

Topics:

- [Unpack](#)
- [Rack or cabinet hardware installation](#)
- [Switch installation](#)
- [Ground cable](#)
- [Optics installation](#)
- [Switch power-up](#)

Unpack

NOTE: Before unpacking the switch, inspect the container and immediately report any evidence of damage.

When unpacking the S3048-ON switch, make sure that the following items are included:

- One S3048-ON switch
- One RJ-45 to DB-9 female cable
- Two sets of rail kits, no tools required
- One PSU, a second PSU is sold separately
- Three fan units
- One AC country/region-specific power cord
- *Dell Networking S3048–Open Networking (ON) Getting Started Guide*
- *Safety and Regulatory Information*
- *Warranty and Support Information*

Unpacking steps

- 1 Place the container on a clean, flat surface and cut all straps securing the container.

- 2 Open the container or remove the container top.
- 3 Carefully remove the switch from the container and place it on a secure and clean surface.
- 4 Remove all packing material.
- 5 Inspect the product and accessories for damage.

Rack or cabinet hardware installation

You may either place the switch on a rack shelf or mount the switch directly into a 19" wide, EIA-310- E-compliant rack—four-post, two-post, or threaded methods. The Dell EMC ReadyRails™ system is provided for 1U front-rack and two-post installations.

The ReadyRails system includes two separately packaged rail assemblies and two rails that are shipped attached to the sides of the switch.

⚠ WARNING: This is a condensed reference. Read the safety instructions in your Safety, Environmental, and Regulatory information booklet before you begin.

📘 NOTE: The illustrations in this document are not intended to represent a specific switch.

📘 NOTE: Do not use the mounted ReadyRails as a shelf or a workplace.

Rack mount safety considerations

- Rack loading—Overloading or uneven loading of racks may result in shelf or rack failure, causing damage to the equipment and possible personal injury. Stabilize racks in a permanent location before loading begins. Mount the components beginning at the bottom of the rack, then work to the top. Do not exceed your rack's load rating.
- Power considerations—Connect only to the power source specified on the unit. When multiple electrical components are installed in a rack, ensure that the total component power ratings do not exceed the circuit capabilities. Overloaded power sources and extension cords present fire and shock hazards.
- Elevated ambient temperature—If installed in a closed rack assembly, the operating temperature of the rack environment may be greater than the room ambient temperature. Use care not to exceed the 45°C maximum ambient temperature of the switch.
- Reduced air flow—Install the equipment in the rack so that the amount of airflow required for safe operation of the equipment is not compromised.
- Reliable earthing—Maintain reliable earthing of rack-mounted equipment. Pay particular attention to the supply connections other than the direct connections to the branch circuit, for example: use of power strips.
- Do not mount the equipment with the rear panel facing in the downward position.

ReadyRails system installation

The ReadyRails rack mounting system is provided to easily configure your rack for installation of your S3048-ON switch.

You can install the ReadyRails system using the 1U tool-less method or one of three 1U tooled methods—two-post flush mount, two-post center mount, or four-post threaded.

- 1 With the ReadyRails flange ears facing outward, place one rail between the left and right vertical posts.
Align and seat the rear flange rail pegs in the rear vertical post flange. In the following illustration, item 1 and its extractions show how the pegs appear in both the square and non-threaded round holes.

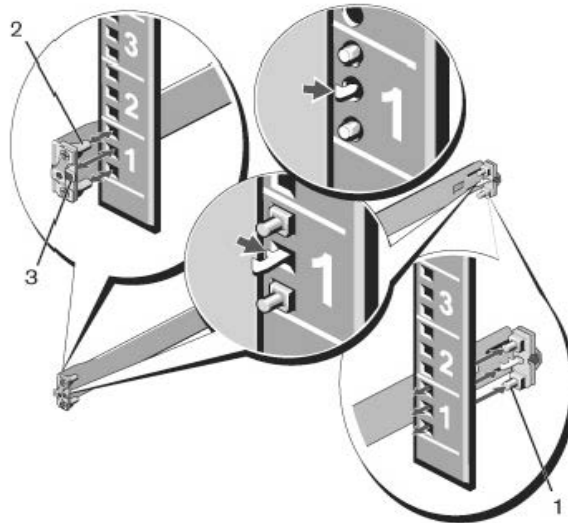

Figure 5. 1U tool-less configuration

- 2 Align and seat the front flange pegs in the holes on the front side of the vertical post, item 2.
- 3 Repeat this procedure for the second rail.
- 4 To remove each rail, pull on the latch release button on each flange ear and unseat each rail, item 3.

Two-post flush-mount installation

- 1 For this configuration, remove the castings from the front side of each ReadyRails assembly, item 1.
To remove the two screws from each front flange ear on the switch side of the rail and remove each casting, use a Torx screwdriver. Retain the castings for future rack requirements. It is not necessary to remove the rear flange castings.

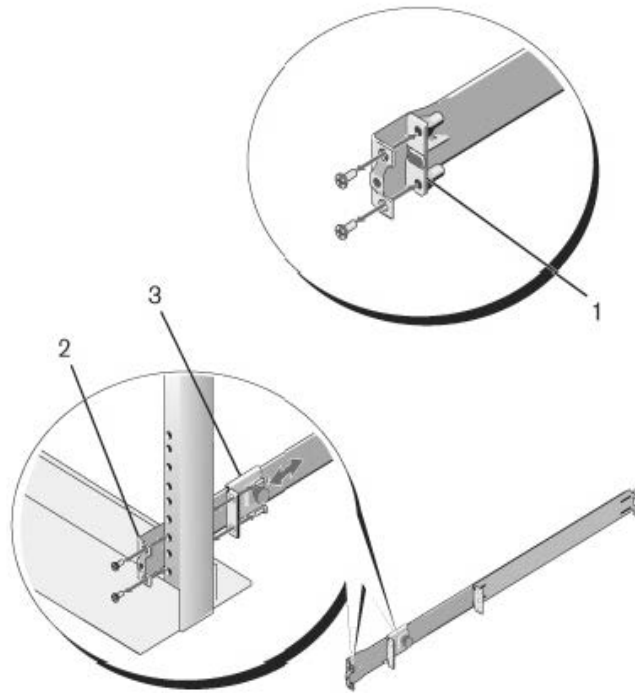

Figure 6. Two-post flush-mount configuration

- 2 Attach one rail to the front post flange with two user-supplied screws, item 2.
- 3 Slide the plunger bracket forward against the vertical post and secure the plunger bracket to the post flange with two user-supplied screws, item 3.
- 4 Repeat this procedure for the second rail.

Two-post center-mount installation

- 1 Slide the plunger bracket rearward until it clicks into place and secure the bracket to the front post flange with two user-supplied screws, item 1.

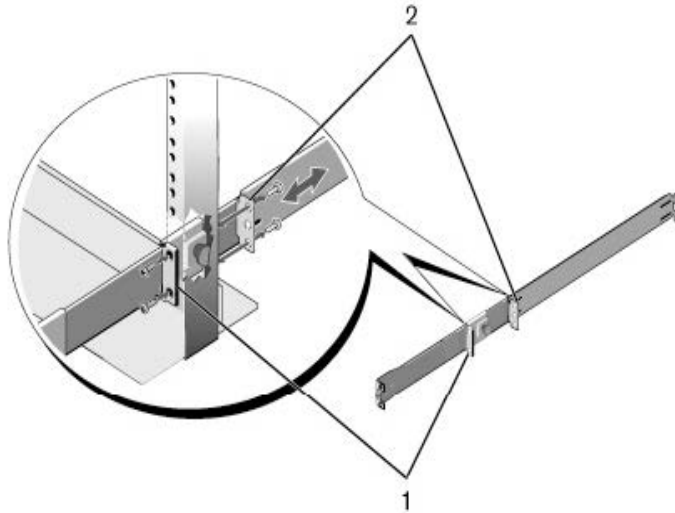

Figure 7. Two-post center-mount configuration

- 2 Slide the back bracket towards the post. Secure it to the post flange with two user-supplied screws, to item 2.
- 3 Repeat this procedure for the second rail.

Four-post threaded installation

- 1 For this configuration, remove the flange ear castings from each end of the ReadyRails assemblies.
To remove the two screws from each flange ear and remove each casting, use a Torx driver, item 1. Retain the castings for future rack requirements.

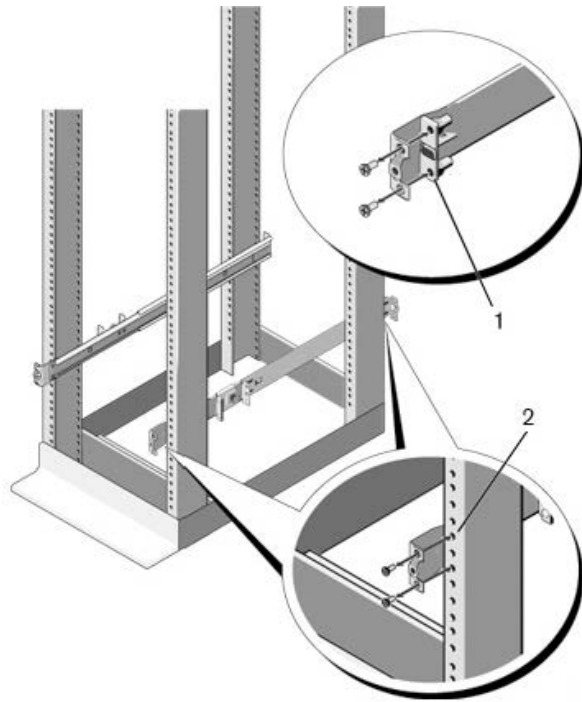

Figure 8. Four-post threaded configuration

- 2 For each rail, attach the front and rear flanges to the post flanges with two user-supplied screws at each end, item 2.

Switch installation

You can mount the switch in the 1U front-rack or 1U flush or center two-post configurations. The following is an example of a front-rack configuration:

For the 1U flush or center two-post configurations, slide the switch into the rails in the same manner as the four-post configurations.

1U front-rack installation

Configure the rails that are attached to the switch.

- 1 Attach the inner chassis members switch rails to the S3048-ON switch. Item 3 shows the detail for the front standoff with the locking tab.

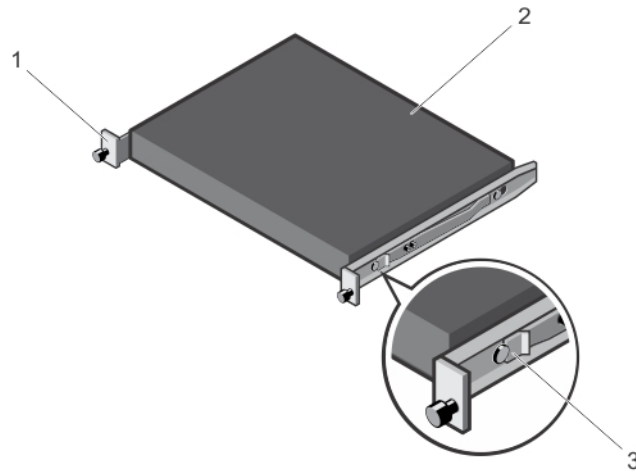

Figure 9. Switch rails attachment

- 2 After you have installed both switch rails, line them up on the previously mounted Ready-Rails and slide the switch in until it is flush with front of rack.
About three inches before you fully insert your switch, the rail locking feature engages to keep the switch from inadvertently sliding out of the rack and falling.

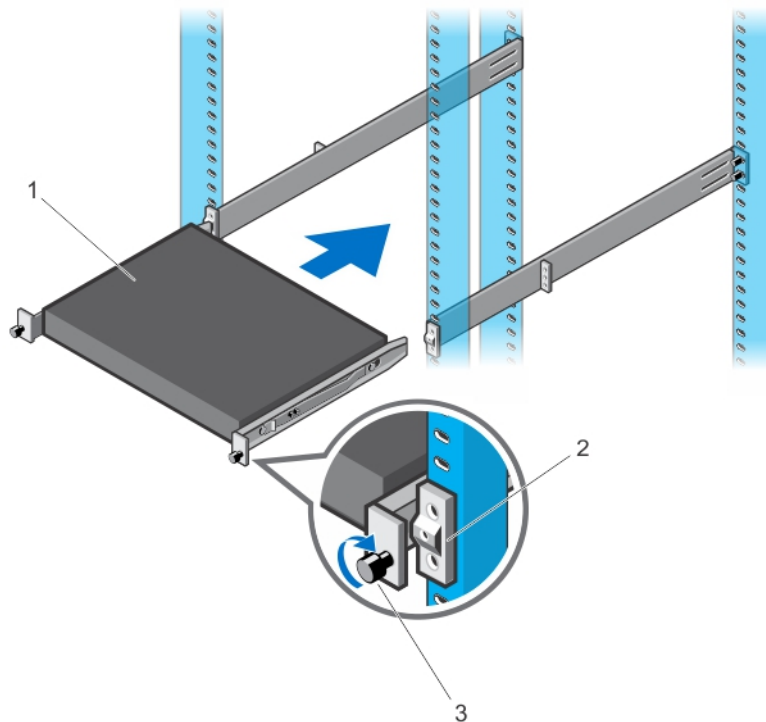

Figure 10. Front rack installation

① **NOTE:** Do not the use the mounted ReadyRails as a shelf or a workplace.

Ground cable

Dell EMC recommends you ground your switch. To attach the ground cable to the chassis, use a single M4x0.7 screw. The cable itself is not included with the S3048-ON switch.

To properly ground the chassis, Dell EMC recommends using a 6 AWG one-hole lug, #10 hole size, 63" spacing, not included in shipping. The one-hole lug must be a UL recognized, crimp-type lug.

⚠ CAUTION: Grounding conductors *must* be made of copper. Do not use aluminum conductors.

ⓘ NOTE: The rack installation ears are not suitable for grounding.

ⓘ NOTE: Coat the one-hole lug with an antioxidant compound before crimping. Also, bring any unplated mating surfaces to a shiny finish and coat with an antioxidant before mating. Plated mating surfaces must be clean and free from contamination.

- 1 Cut the ground cable to the desired length.
The cable length must facilitate proper operation of the fault interrupt circuits. Dell EMC recommends using the shortest cable route allowable.
- 2 Take the one M4x0.7 screw from the package.
- 3 Attach the one-hole lug to the chassis using the supplied 10-32 screw with the captive internal tooth lock washer. Torque the screw to 20 in-lbs.
- 4 Attach the other end of the ground cable to a suitable ground point.
The rack installation ears are not a suitable grounding point.

Optics installation

The S3048-ON has four SFP+ optical ports.

For a list of supported optics, see the S3048-ON data sheet at www.dell.com/support or contact your Dell EMC representative.

⚠ CAUTION: ESD damage can occur if components are mishandled. Always wear an ESD-preventive wrist or heel ground strap when handling the S3048-ON and its components.

⚠ WARNING: When working with optical fibers, follow all warning labels and always wear eye protection. Never look directly into the end of a terminated or unterminated fiber or connector as it may cause eye damage.

- 1 Position the optic so it is in the correct position.
The optic has a key that prevents it from being inserted incorrectly.
- 2 Insert the optic into the port until it gently snaps into place.

ⓘ NOTE: When you cable the ports, be sure not to interfere with the airflow from the small vent holes above and below the ports.

Optics removal

Remove an optic by pushing the tab on the optic and sliding the optic from the port.

When removing optics with direct attach cables (DACs) from the port, pull the release tab firmly and steadily. Before pulling the release tab, you may need to gently push the optic into the port to ensure it is seated properly. Do not jerk or tug repeatedly on the tab.

Switch power-up

Supply power to the S3048-ON after it is mounted in a rack or cabinet.

Dell EMC recommends reinspecting your switch before powering up. Verify the following:

- The equipment is properly secured to the rack and properly grounded, optional.

- The equipment rack is properly mounted and grounded, optional.
- The ambient temperature around the unit, which may be higher than the room temperature, is within the limits specified for the S3048–ON. For more information, see [Specifications](#).
- There is sufficient airflow around the unit.
- The input circuits are correctly sized for the loads and that you use sufficient overcurrent protection devices.
- All protective covers are in place.
- Blank panels are installed if you do not install optional modules.

NOTE: A US AC power cable is included for powering up an AC power supply. You must order all other power cables separately.

NOTE: ESD damage can occur if components are mishandled. Always wear an ESD-preventive wrist or heel ground strap when handling the S3048–ON switch and its components.

Power up sequence

When the switch powers up, the fans immediately come on at high speed. The fan speed slows as the switch continues to boot up.

Power supplies

The S3048-ON ships with one AC power supply. Dell EMC recommends purchasing a second power supply.

The S3048-ON supports AC power supplies with two air-flow directions—from the I/O side to the PSU side and from the PSU side to the I/O side. Two PSUs are required for full redundancy, but the switch can operate with a single PSU.

The PSUs are field replaceable. When running with full redundancy—two power supplies installed and running, you can remove and replace one PSU without disrupting traffic.

CAUTION: To prevent electrical shock, ensure that the S3048-ON is grounded properly. If you do not ground your equipment correctly, excessive emissions may result. Use a qualified electrician to ensure that the power cables meet your local electrical requirements.

NOTE: If you use a single PSU, install a blank plate in the other PSU slot. Dell EMC recommends using power supply 2 (PSU2) as the blank plate slot. Use a #1 Philips screw driver to install the blank plate.

NOTE: ESD damage can occur if components are mishandled. Always wear an ESD-preventive wrist or heel ground strap when handling the S3048-ON and its components.

Topics:

- [Components](#)
- [AC power supply installation](#)
- [AC power supply replacement](#)

Components

The following power supply options are available for the S3048-ON:

- AC power supply with integrated fan
- AC power supply with integrated reverse flow fan

Power supply 1 (PSU1) is on the left side of the chassis; power supply 2 (PSU2) is on the right side of the chassis.



Figure 11. S3048-ON PSUs

1 PSU 1 and 2

The PSUs have an integrated fan, which you cannot replace individually. If the fan integrated in a PSU fails, you must replace the entire PSU. You can replace the fan trays individually. For fan tray replacement procedures, see [Fans](#).

- ⚠ WARNING:** Prevent exposure and contact with hazardous voltages. Do not attempt to operate this switch with the safety cover removed.
- ⚠ CAUTION:** Remove the power cable from the PSU prior to removing the PSU. Also, do not connect the power cable before you insert the PSU in the chassis.
- ⓘ NOTE:** To comply with the GR-1089 Lightning Criteria for Equipment Interfacing with AC Power Ports, use an external surge protection device (SPD) at the AC input of the router.

AC power supply installation

- ⓘ NOTE:** The PSU slides into the slot smoothly. Do not force a PSU into a slot as this action may damage the PSU or the S3048-ON chassis.
- ⓘ NOTE:** Ensure that you correctly install the PSU. When you install the PSU correctly, the power connector is on the right side of the PSU.
- ⓘ NOTE:** If you use a single PSU, install a blank plate in the other PSU slot. If you are only using one power supply, Dell EMC recommends installing the power supply in the first slot (PSU1) and installing a blank plate in the second slot (PSU2).

- 1 Remove the PSU slot cover from the S3048-ON using a small #1 Phillips screwdriver.
- 2 Remove the PSU from the electro-static bag.
- 3 Insert the PSU into the switch PSU slot. Insert the PSU exposed PCB edge connector first. The PSU slot is keyed so that the PSU can only be fully inserted in one orientation.

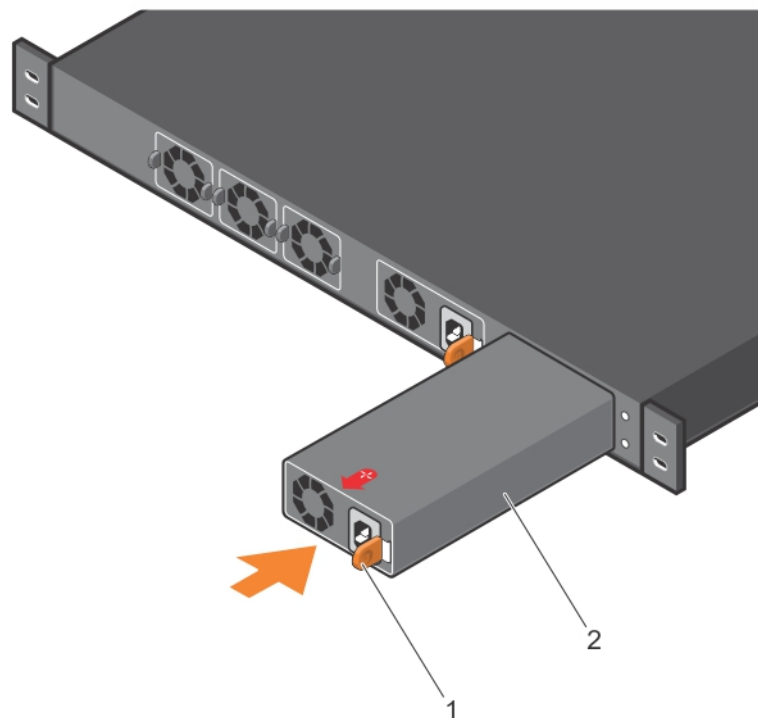

Figure 12. PSU installation

When you install the PSU correctly, it snaps into place and is flushed with the back of the switch.

- 4 Plug in the appropriate AC three-prong power cord from the switch PSU to the external power source.
- 5 If you have a redundant PSU, repeat steps 1 through 4 above using the second PSU slot on the S3048-ON switch.

ⓘ **NOTE:** The S3048-ON powers up when you connect the cables between the power supply and the power source.

AC power supply replacement

⚠ **CAUTION:** Disconnect the power cord before removing the power supplies. Also, disconnect all power cords before servicing.

ⓘ **NOTE:** The PSU slides into the slot smoothly. Do not force a PSU into a slot as this action may damage the PSU or the S3048-ON chassis.

ⓘ **NOTE:** If a PSU fails, you must replace the entire unit. There are no field serviceable components in the PSU.

ⓘ **NOTE:** If you use a single PSU, install a blank plate in the other PSU slot. If you are only using one power supply, Dell EMC recommends installing the power supply in the first slot (PSU1) and installing a blank plate in the second slot (PSU2).

- 1 Disconnect the power cable from the PSU.
- 2 Use the grab handle to slide the PSU out of the power supply bay.
- 3 Use the grab handle on the replacement PSU to slide it into the power supply bay.
- 4 Attach the power cord to the replacement PSU.

ⓘ **NOTE:** The switch powers up when you connect the cables between the power supply and the power source.

Fans

The S3048-ON comes from the factory with one PSU and three fan modules installed in the chassis. The fan modules and the power supplies, which have integrated fans, are hot-swappable.

NOTE: To run the switch, all slots must have operating fan units. If you do not install a module in each slot either as part of the PSU or as an independent fan module, the switch shuts down in one minute.

In addition to the power supply modules, you can order and install fan modules separately.

The S3048-ON supports two airflow direction options. Do not mix airflow types in a chassis; you can use only a single airflow direction in a chassis. If the airflow directions are mismatched, the S3048-ON issues an alarm. You must correct the mismatched airflow direction.

- Normal—airflow is from the I/O panel to the PSU.
- Reversed—airflow is from the PSU to the I/O panel.

All fans and PSUs in a configuration must be in the same airflow direction.

Environmental factors can decrease the amount of time required between fan replacements. Check the environmental factors regularly. An increase in temperature and/or particulate matter in the air might affect performance; for example, new equipment installation.

CAUTION: Check the fans at six-month intervals and replace them as necessary. Regularly monitor the speeds of the fans to accurately determine replacement intervals.

Topics:

- [Components](#)
- [Fan module installation](#)
- [Fan module replacement](#)
- [After installing the switch](#)

Components

The following are the S3048-ON fan components.

- S3048-ON Fan module
- S3048-ON Fan module—Reverse flow



Figure 13. S3048-ON fan modules

Fan module installation

The fan modules in the S3048-ON are field replaceable.

Module slot 1 is on the left side of the chassis, module slot 2 is in the middle of the chassis, and module slot 3 is on the right side of the chassis.

△ CAUTION: DO NOT mix airflow directions. All fans must use the same airflow direction—reverse or normal. If you mix the airflow direction, the switch detects the discrepancy and issues an alarm. You must correct the mixed airflow direction.

- 1 Take the fan module out of the shipping box.
- 2 Slide the module into the bay.

Fan module replacement

△ CAUTION: Complete steps 2 and 3 within one minute or the switch powers down.

- 1 Slide the fan module out of the bay.
- 2 Slide the replacement module into the bay.

After installing the switch

After you have securely installed and powered on the S3048-ON, to configure your switch, see your ONIE-compatible operating system documentation.

Management ports

Besides the 10/100/1000Base-T RJ-45 ports, the S3048-ON switch provides several ports for management and storage.

Topics:

- [RS-232 console port access](#)
- [Before you install an OS](#)
- [ONIE service discovery](#)

RS-232 console port access

The RS-232 console port is on the I/O-side of the S3048-ON chassis, as shown.



Figure 14. S3048-ON RS-232 console ports

- 1 RS-232 Console Port, top
- 2 Ethernet management port, bottom

NOTE: When connecting the RJ45 console to the patch panel or terminal server using Cat5e or Cat6 Ethernet cables, the maximum cable length is 100m. However, if the Ethernet cable is disconnected from the patch panel or terminal server but connected to the RJ45 console, the maximum cable length is 6m. If the cable is longer than 6m when disconnected from the panel or server, your switch may not boot.

NOTE: Before starting this procedure, be sure that your PC has a 9-pin serial port and that you have a terminal emulation program already installed and running on the PC.

NOTE: If your PC's serial port cannot accept a female DB-9 connector, acquire a DB-9 male-to-male adaptor.

- 1 Install the provided RJ-45 connector side of the provided cable into the S3048-ON console port.
- 2 Install the DB-9 female side of the provided copper cable into your PC's serial port or into other data terminal equipment (DTE) server hardware that you intend to use.
- 3 Keep the default terminal settings on the console as follows:
 - 115200 baud rate
 - No parity
 - 8 data bits
 - 1 stop bit
 - No flow control

USB-B console port access

The USB-B console port is on the I/O side of the S3048-ON.

The terminal settings are the same for the serial console port and the RS-232/RJ-45 console port:

- 115200 baud rate
- No parity
- 8 data bits
- 1 stop bit
- No flow control

When you connect the USB-B port, it becomes the primary connection and, while connected, all messages are sent to the USB-B port.

NOTE: Before starting this procedure, be sure you have a terminal emulation program already installed on your PC. You will need to install the appropriate drivers to support the USB-B port. For assistance, contact www.dell.com/support to download the drivers.

To access the USB-B console port, follow these steps.

- 1 Power on the PC.
- 2 Connect the USB-A end of cable into an available USB port on the PC.
- 3 Connect the USB-B end of cable into the USB-B console port on the S3048-ON.
- 4 Power on the S3048-ON.
- 5 Install the necessary USB device drivers.
To download the drivers, go to www.dell.com/support. For assistance, contact Dell EMC Technical Support.
- 6 Open your terminal software emulation program to access the S3048-ON.
- 7 Confirm the terminal settings on your terminal software emulation program are as follows:
 - 115200 baud rate
 - No parity
 - 8 data bits
 - 1 stop bit
 - No flow control

USB storage mount

The USB storage supports the FAT file system. The USB storage does not automatically mount. To use USB storage, you must first mount the device.

- 1 Create a mount directory for the USB.

```
ONIE:/ # mkdir /mnt/usb
```
- 2 View the fixed disks using the `fdisk` command.

```
ONIE:/mnt # fdisk -l
```

For internal storage:

```
Disk /dev/sda: 15.8 GB, 15829303296 bytes
255 heads, 63 sectors/track, 1924 cylinders
Units = cylinders of 16065 * 512 = 8225280 bytes
```

Device	Boot	Start	End	Blocks	Id	System
/dev/sda1		1	1925	15458303+	ee	EFI GPT

For USB storage:

```
Disk /dev/sdb: 30.9 GB, 30942946304 bytes
64 heads, 32 sectors/track, 29509 cylinders
Units = cylinders of 2048 * 512 = 1048576 bytes
```

Device	Boot	Start	End	Blocks	Id	System
--------	------	-------	-----	--------	----	--------

- 3 Mount the device /dev/sdb to the /mnt/usb directory.

```
ONIE:/ # mount -t vfat /dev/sdb /mnt/usb
```

① **NOTE:** The following message displays if the /mnt/usb directory is missing: `mount: mounting /dev/sdb on /mnt/usb failed: No such file or directory.`

① **NOTE:** The following message displays if the USB device is not seen: `mount: mounting /dev/sdb on /mnt/usb failed: No such device or address.`

- 4 OPTIONAL: Add a device to the file systems table, `fstab`, and mount the file systems.

```
ONIE:/ # vi /etc/fstab
```

```
# FSTAB entry for the ONIE-BOOT partition mounted on /boot
LABEL=ONIE-BOOT /mnt/onie-boot ext4 defaults,rw,errors=remount-ro 0 1
/dev/sdb /mnt/usb vfat defaults 0 1
```

```
ONIE:/ # mount -a
```

Before you install an OS

After powering on the S3048-ON switch, it goes through a power-on self-test (POST).

POST runs every time the switch is initialized and checks the hardware components to determine if the switch is fully operational before booting. After POST, the switch uses the Grub bootloader.

To select which entry is highlighted, use the up and down arrow keys. Press **Enter** to select an OS or enter `e` to edit the commands before booting. Enter `c` for a command line. The highlighted entry executes automatically in the operating system.

Example of the Grub Bootloader

```
GNU GRUB version 2.02~beta2+e4a1fe391
```

```
+-----+
| *ONIE: Install OS |
| ONIE: Rescue |
| ONIE: Uninstall OS |
| ONIE: Update ONIE |
| ONIE: Embed ONIE |
| ONIE: Diag ONIE |
| Dell EMC DIAG |
| |
| |
| |
| |
+-----+
```

Your switch comes with ONIE installed.

Example of ONIE

```
ONIE: Install OS
For downloading and installing an OS from a URL
```

```

    Starts ONIE with ONIE Discovery Service
    (factory default boot)
ONIE: Rescue
    Starts ONIE without ONIE Discovery Service
    Useful for running Diagnostics manually
ONIE: Uninstall OS
    Restore to factory defaults erases any installed OS
ONIE: Update ONIE
    For downloading and updating ONIE from a URL
ONIE: Embed ONIE
    For downloading and updating ONIE from a URL and erases any installed OS
ONIE: Diag ONIE
    Run Diagnostic package for S3048-ON
Dell EMC DIAG
    Run Dell EMC Networking Diagnostic package for <platform>

```

During the initial setup, the switch boots to ONIE Install. ONIE Install boots with ONIE Discovery to the console (ONIE:).

ONIE service discovery

ONIE attempts to locate the installer through several discovery methods, as shown. To download and run an installer, the ONIE Service Discovery feature uses the first successful method found.

- 1 Search locally attached storage devices for one of the ONIE default installer filenames—for example, the filename is: `onie_self_update` from the USB.
- 2 Query to the IPv4 and IPv6 link-local neighbors using HTTP for an installer.
- 3 Discover TFTP-based image from the DHCP server4.

Examples of the ONIE `ifconfig eth0` Commands

If none of the ONIE Service Discovery methods are successful, you can disable this using the `onie-discovery-stop` command.

You can install an operating system manually from HTTP, FTP, or TFTP using the `onie-nos-install <URL>` command.

NOTE: If you have a recovery USB plugged into your switch, you must remove it before installing the DIAG-OS using the `onie-nos-install` command.

The ONIE Install environment uses DHCP to assign an IP address to the management interface, `eth0`. If that fails, it uses the default IP address `192.168.3.10/255.255.255.0`.

To display the IP address, use the `ifconfig eth0` command, as shown.

```

ONIE:/ # ifconfig eth0
eth0 Link encap:Ethernet HWaddr 90:B1:1C:F4:9C:76
      inet addr:10.11.53.33 Bcast:10.255.255.255 Mask:255.0.0.0
      inet6 addr: fe80::92b1:1cff:fef4:9c76/64 Scope:Link
      UP BROADCAST RUNNING MULTICAST MTU:1500 Metric:1
      RX packets:18 errors:0 dropped:0 overruns:0 frame:0
      TX packets:24 errors:0 dropped:0 overruns:0 carrier:0 collisions:0 txqueuelen:1000
      RX bytes:1152 (1.1 KiB) TX bytes:6864 (6.7 KiB)
      Interrupt:21 Memory:ff300000-ff320000

```

To assign an IP address to the management interface, `eth0`, and verify network connectivity, use the `ifconfig eth0 <ip address>` command, as shown.

```

ONIE:/ # ifconfig eth0 10.11.53.33/16

Verify the network connection with ping.
ONIE:/ # ping 10.11.8.12
PING 10.11.8.12 (10.11.8.12): 56 data bytes
64 bytes from 10.11.8.12: seq=0 ttl=62 time=1.357 ms
64 bytes from 10.11.8.12: seq=1 ttl=62 time=0.577 ms
^C

```

Specifications

This chapter lists the S3048-ON specifications.

⚠ CAUTION: Operate the product at an ambient temperature not higher than 113°F (45°C).

⚠ CAUTION: Lithium Battery Caution: There is a danger of explosion if the battery is incorrectly replaced. Replace only with same or equivalent type of battery. Dispose of the batteries according to the manufacturer's instructions.

ℹ NOTE: For RoHS information, see [Restricted Material Compliance](#).

Topics:

- Chassis physical design
- IEEE Standards
- Agency compliance
- USA Federal Communications Commission Statement
- European Union EMC Directive Conformance Statement
- Japan VCCI Compliance for Class A Equipment
- Korean Certification of Compliance
- Safety Standards and Compliance Agency Certifications
- Electromagnetic compatibility
- Product recycling and disposal

Chassis physical design

Table 4. Chassis physical design

Parameter	Specifications
Height	1.73 inches (44 mm)
Width	17.09 inches (434 mm)
Depth	12.60inches (320 mm)
Chassis Weight with Factory-Installed Components	6.55kg (2*PSUs)
	5.65kg (1*PSU)
Rack Clearance Required	Front: 5 inches (12.7 cm)
	Rear: 5 inches (12.7 cm)

Table 5. Environmental parameters

Parameter	Specifications
Operating Temperature	32° to 113°F (0° to 45°C)
Operating Humidity	5 to 85% (RH), non-condensing

Parameter	Specifications
Storage Temperature	-40° to 158°F (-40° to 70°C)
Storage Humidity	5 to 95%, non-condensing
Maximum Thermal Output	292.42 BTU/hr 85.7W
Maximum operational altitude	10,000 feet (3,048 meters)
Maximum non-operational altitude	No performance degradation to 35,000 feet (10,668 meters)
Shock	SV0115 — ODM

Table 6. AC power requirements

Parameter	Specifications
Power Supply	100–240 VAC 50/60 Hz
Maximum Current Draw Per System	3A @ 100vac 2A @ 200vac
PSU Maximum Power Capability	224.4 Watts
PSU Maximum Power Capability, North America Only	424.0 Watts
Typical Power Consumption	200 Watts
Reliability	MTBF 1,154,397 hours

IEEE Standards

The S3048-ON complies with the following IEEE standards.

- 802.3ab Gigabit Ethernet (1000BASE-T)
- 802.3ae 10 Gigabit Ethernet (10GBASE-X)
- 802.3u Fast Ethernet (100BASE-TX)
- 802.3z Gigabit Ethernet (1000BASE-X)

Agency compliance

The S3048-ON is designed to comply with the following safety and agency requirements:

USA Federal Communications Commission Statement

This equipment has been tested and found to comply with the limits for a Class A digital device, pursuant to Part 15 of the FCC rules. These limits are designated to provide reasonable protection against harmful interference when the equipment is operated in a commercial environment. This equipment generates, uses, and can radiate radio frequency energy. If it is not installed and used in accordance to the instructions, it may cause harmful interference to radio communications. Operation of this equipment in a residential area is likely to cause harmful interference, in which case users will be required to take whatever measures necessary to correct the interference at their own expense.

Properly shielded and grounded cables and connectors must be used in order to meet FCC emission limits. Dell Networking is not responsible for any radio or television interference caused by using other than recommended cables and connectors or by unauthorized changes or modifications in the equipment. Unauthorized changes or modification could void the user's authority to operate the equipment.

This device complies with Part 15 of the FCC Rules. Operation is subject to the following two conditions: (1) this device may not cause harmful interference, and (2) this device must accept any interference received, including interference that may cause undesired operation.

Industry Canada Class A emission compliance statement

This Class A digital apparatus complies with Canadian ICES-003.

Avis de conformité à la réglementation d'Industrie Canada

Cet appareil numérique de la classe A est conforme à la norme NMB-003 du Canada.

Figure 15. Canadian Department of Communication Statement

European Union EMC Directive Conformance Statement

This product is in conformity with the protection requirements of EU Council Directive 2004/108/EC on the approximation of the laws of the Member States relating to electromagnetic compatibility. Dell EMC can not accept responsibility for any failure to satisfy the protection requirements resulting from a non-recommended modification of this product, including the fitting of non-Dell EMC option cards.

This product has been tested and found to comply with the limits for Class A Information Technology Equipment according to CISPR 22/ European Standard EN 55022. The limits for Class A equipment were derived for commercial and industrial environments to provide reasonable protection against interference with licensed communication equipment.

⚠ WARNING: This is a Class A product. In a domestic environment, this device may cause radio interference, in which case, you may be required to take adequate measures.

European Community Contact

Dell EMC, EMEA - Central

Dahlienweg 19

66265 Heusweiler

Germany

<http://www.force10networks.com/german/>

Tel: +49 172 6802630

Email: EMEA Central Sales

Japan VCCI Compliance for Class A Equipment

この装置は、情報処理装置等電波障害自主規制協議会（VCCI）の基準に基づくクラスA情報技術装置です。この装置を家庭環境で使用すると電波妨害を引き起こすことがあります。この場合には使用者が適切な対策を講ずるよう要求されることがあります。

Figure 16. Japan VCCI Compliance for Class A Equipment

This is Class A product based on the standard of the Voluntary Control Council For Interference by Information Technology Equipment (VCCI). If this equipment is used in a domestic environment, radio disturbance may arise. When such trouble occurs, the user may be required to take corrective actions.

⚠ WARNING: Use the AC power cords with Dell EMC equipment only. Do not use Dell Force10 AC power cords with any unauthorized hardware.

本製品に同梱いたしております電源コードセットは、本製品専用です。本電源コードセットは、本製品以外の製品ならびに他の用途でご使用いただくことは出来ません。製品本体には同梱された電源コードセットを使用し、他製品の電源コードセットを使用しないで下さい。

Figure 17. Japan Warning Label

Korean Certification of Compliance

A급 기기 (업무용 방송통신기자재)	이 기기는 업무용(A급) 전자파적합기기로서 판매자 또는 사용자는 이 점을 주의하시기 바라며, 가정외의 지역에서 사용하는 것을 목적으로 합니다.
------------------------	---

Figure 18. Korean Certification of Compliance

	 [equipment type]
품명(Product Name)	Ethernet Switch
모델명(Model)	[model number]
신청인(Applicant)	Force10 Networks, Inc.
제조사(Manufacturer)	Delta Networks, (Dongguan) Ltd.
제조년월(Manufacturing Date)	[date]
제조국(Country of Origin)	China

Figure 19. Korean Package Label

Safety Standards and Compliance Agency Certifications

- CUS UL 60950-1, 2nd Edition
 - Meets or exceeds Hi Pot and Ground Continuity testing per UL 60950-1.
- CSA 60950-1-03, 2nd Edition
- EN 60950-1, 2nd Edition
- EN 60825-1, 1st Edition
- EN 60825-1 Safety of Laser Products—Part 1: Equipment Classification Requirements and User's Guide
- EN 60825-2 Safety of Laser Products—Part 2: Safety of Optical Fibre Communication Systems
- FDA Regulation 21CFR 1040.10 and 1040.11
- IEC 60950-1, 2nd Ed, including all National Deviations and Group Differences

Electromagnetic compatibility

Emissions

- International: CISPR 22: 2006, Class A
- Australia/New Zealand: AS/NZS CISPR 22:2009, Class A
- Canada: ICES-003, Issue-4, Class A
- Europe: EN55022 2006 (CISPR 22: 2006), Class A
- Japan: VCCI V-3/2011.04 Class A
- USA: FCC CFR47 Part 15, Subpart B, Class A

Immunity

- EN 300 386 v1.5.1:2010 EMC for Network Equipment
- EN55022 2006, Class A
- EN 55024 1998 + A1: 2001 + A2: 2003
- EN 61000-3-2 Harmonic Current Emissions
- EN 61000-3-3 Voltage Fluctuations and Flicker
- EN 61000-4-2 ESD
- EN 61000-4-3 Radiated Immunity
- EN 61000-4-4 EFT
- EN 61000-4-5 Surge
- EN 61000-4-6 Low Frequency Conducted Immunity

Product recycling and disposal

You must recycle or discard this system according to applicable local and national regulations. Dell EMC encourages owners of information technology (IT) equipment to responsibly recycle their equipment when it is no longer needed. Dell EMC offers a variety of product return programs and services in several countries to assist equipment owners in recycling their IT products.

Waste Electrical and Electronic Equipment (WEEE) Directive for Recovery, Recycle and Reuse of IT and Telecommunications Products

Dell EMC switches are labeled in accordance with European Directive 2002/96/EC concerning waste electrical and electronic equipment (WEEE). The Directive determines the framework for the return and recycling of used appliances as applicable throughout the European Union. This label is applied to various products to indicate that the product is not to be thrown away, but rather reclaimed upon end of life per this Directive.



Figure 20. European WEEE symbol

In accordance with the European WEEE Directive, electrical and electronic equipment (EEE) is to be collected separately and to be reused, recycled, or recovered at end of life. Users of EEE with the WEEE marking per Annex IV of the WEEE Directive, as shown above, must not dispose of end of life EEE as unsorted municipal waste, but use the collection framework available to customers for the return, recycling and recovery of WEEE. Customer participation is important to minimize any potential effects of EEE on the environment and human health due to the potential presence of hazardous substances in EEE.

Dell EMC products, which fall within the scope of the WEEE, are labeled with the crossed-out wheeled-bin symbol, as shown above, as required by WEEE.

For information on Dell EMC product recycling offerings, see the WEEE Recycling instructions on Support. For more information, contact the Dell EMC Technical Assistance Center.

Dell EMC support

The Dell EMC support site provides documents and tools to help you effectively use Dell EMC equipment and mitigate network outages. Through the support site you can obtain technical information, access software upgrades and patches, download available management software, and manage your open cases. The Dell EMC support site provides integrated, secure access to these services.

To access the Dell EMC support site, go to www.dell.com/support/. To display information in your language, scroll down to the bottom of the web page and select your country from the drop-down menu.

- To obtain product-specific information, enter the 7-character service tag, known as a luggage tag, or 11-digit express service code of your switch and click **Submit**.
To view the chassis service tag or express service code, pull out the tag or enter the `show chassis` command from the CLI.
- To receive more technical support, click **Contact Us**. On the Contact Information web page, click **Technical Support**.

To access switch documentation, go to www.dell.com/manuals/.

To search for drivers and downloads, go to www.dell.com/drivers/.

To participate in Dell EMC community blogs and forums, go to www.dell.com/community.