



Lenovo ThinkSystem SR950 Server Product Guide

Lenovo ThinkSystem SR950 is designed for your most demanding, mission-critical workloads, such as in-memory databases, large transactional databases, batch and real-time analytics, ERP, CRM, and virtualized server workloads. The powerful 4U ThinkSystem SR950 can grow from two to eight Intel Xeon Scalable Family processors, and with 96 DIMM sockets, supports up to 12 TB of high-speed memory. The modular design of SR950 speeds upgrades and servicing with easy front or rear access to all major subsystems to maximize server availability.

The SR950 packs numerous fault-tolerant and high-availability features into a high-density, 4U rack-optimized design that reduces the space needed to support massive network computing operations and simplify servicing.

The following figure shows the Lenovo ThinkSystem SR950.



Figure 1. Lenovo ThinkSystem SR950

Did you know?

The SR950 server supports up to eight processors in a single 4U chassis. You can upgrade from a 2-socket system to an 8-socket system without having to replace the server enclosure or upgrade to a physically larger design. The SR950 offers enterprise scalability and advanced RAS features to support the most demanding mission-critical applications that require 24x7 operations.

Key features

Lenovo ThinkSystem SR950 is designed for your most demanding, mission-critical workloads, such as in-memory databases, large transactional databases, batch and real-time analytics, ERP, CRM, and virtualized server workloads. The powerful 4U ThinkSystem SR950 can grow from two to eight Intel Xeon Processor Scalable Family CPUs, achieving up to 45% faster performance than the previous generation. The modular design of SR950 speeds upgrades and servicing with easy front and rear access to all major subsystems, to maximize server uptime.

Scalability and performance

The SR950 offers numerous features to boost performance, improve scalability, and reduce costs:

- Dense server offering where up to 8 processors and 96 DIMMs are housed in only 4U of rack space.
- Offers a simple upgrade path that enables the server to be initially configured with 2 processors and then later be upgraded to 8 processors simply by adding a compute tray and system boards.
- Supports the Gold and Platinum level processors in the Intel Xeon Processor Scalable Family, including the "top bin" highest-performing 205 W processors available from Intel.
- Up to eight processors, each with up to 28 cores and 56 threads (for a total of up to 448 threads) to maximize the concurrent execution of multithreaded applications.
- Intelligent and adaptive system performance with Intel Turbo Boost Technology 2.0 allows processor cores to run at maximum speeds during peak workloads by temporarily exceeding processor TDP.
- Intel Hyper-Threading Technology boosts performance for multithreaded applications by enabling simultaneous multithreading within each processor core, up to two threads per core.
- Intel Virtualization Technology integrates hardware-level virtualization hooks that allow operating system vendors to better use the hardware for virtualization workloads.
- Support for up to 96 TruDDR4 DIMMs operating at 2666 MHz means you have the fastest available memory subsystem and memory capacity of up to 12 TB using 96x 128 GB 3DS RDIMMs.
- Up to 24x 2.5-inch HDDs or SSDs provide a flexible and scalable all-in-one platform to meet your increasing demands.
- Of the 24x drive bays, support for up to 12 NVMe PCIe SSDs maximizes drive I/O performance, in terms of throughput, bandwidth, IOPS, and latency.
- The use of solid-state drives (SSDs) instead of, or along with, mechanical hard disk drives (HDDs), can improve I/O performance. An SSD can support up to 100 times more I/O operations per second (IOPS) than a typical HDD.
- New high-speed RAID controllers provide 12 Gb SAS connectivity to the drive backplanes. A variety of RAID adapters are available, with cache up to 4 TB and support for 12 drives on a single controller.
- Supports a new Lenovo-patented M.2 adapter design for convenient operating system boot functions. Available M.2 adapters support either one M.2 drive, or two M.2 drives in a RAID 1 configuration, for the boot drive performance and reliability.
- The server has a dedicated flexible LAN-on-motherboard (LOM) slot offering a variety of 10 GbE or Gigabit Ethernet adapters that do not occupy one of the standard PCIe slots.
- A total of up to 17 rear-accessible PCIe slots: 14 general-purpose PCIe 3.0 slots plus slots dedicated to the LOM adapter and two ML2 adapters. In addition, the server has two internal slots for RAID or HBA adapters.
- The server offers PCI Express 3.0 I/O expansion capabilities that improve the theoretical maximum bandwidth by almost 100% (8 GTps per link using 128b/130b encoding) compared to the previous generation of PCI Express 2.0 (5 GTps per link using 8b/10b encoding).

Availability and serviceability

The SR950 provides many features to simplify serviceability and increase system uptime:

- The server offers Single Device Data Correction (SDDC, also known as Chipkill), Adaptive Double-Device Data Correction (ADDDC, also known as Redundant Bit Steering or RBS), memory mirroring, and memory rank sparing for redundancy in the event of a non-correctable memory failure.
- The server offers hot-swap drives, supporting RAID redundancy for data protection and greater system uptime.
- The Dual M.2 Boot Adapter uses RAID-1 so that the two M.2 drives installed are configured as a redundant pair.
- The server has up to four hot-swap N+N redundant power supplies to help keep the server operational in the event of a power supply or utility supply failure
- Each compute tray has 6 hot-swap N+1 redundant fans (a total of 12 fans when two compute trays are installed) to maximize availability for business-critical applications.
- The power source-independent light path diagnostics functionality provides individual light path LEDs that lead the technician to failed (or failing) components, which simplifies servicing, speeds up problem resolution, and helps increase system availability.
- The included LCD system information display panel provides greater diagnostic function by listing all error messages and VPD data needed for a service call, thereby speeding problem resolution and increasing system uptime.
- Proactive Platform Alerts (including PFA and SMART alerts): Processors, voltage regulators, memory, internal storage (SAS/SATA HDDs and SSDs, NVMe SSDs, M.2 storage, and flash storage adapters), fans, power supplies, RAID controllers, and server ambient and subcomponent temperatures. Alerts can be surfaced through the XClarity Controller to managers such as Lenovo XClarity Administrator, VMware vCenter, and Microsoft System Center. These proactive alerts let you take appropriate actions in advance of possible failure, thereby increasing server uptime and application availability.
- Solid-state drives (SSDs) offer more reliability than mechanical HDDs for greater uptime.
- The built-in XClarity Controller continuously monitors system parameters, triggers alerts, and performs recovery actions in case of failures to minimize downtime.
- Built-in diagnostics in UEFI, using Lenovo XClarity Provisioning Manager, speed up troubleshooting tasks to reduce service time.
- Lenovo XClarity Provisioning Manager supports diagnostic functions and collects service data to USB key drive or remote CIFS share folder for troubleshooting, to reduce servicing time.
- Autorestart in the event of a momentary loss of AC power (based on power policy setting in the XClarity Controller service processor)
- Support for the XClarity Administrator Mobile app running on a supported smartphone and connected to the server through the service-enabled USB port, enables additional local systems management functions.
- Three-year or one-year customer-replaceable unit and onsite limited warranty, 9 x 5 next business day. Optional service upgrades are available.

Manageability and security

Powerful systems management features simplify local and remote management of the SR950:

- The server includes an XClarity Controller (XCC) to monitor server availability and perform remote management. XCC Enterprise is included as standard, which enables remote KVM and remote media files (ISO and IMG image files), boot capture, and power capping.

- Lenovo XClarity Administrator offers comprehensive hardware management tools that help to increase uptime, reduce costs and improve productivity through advanced server management capabilities.
- New UEFI-based Lenovo XClarity Provisioning Manager, accessible from F1 during boot, provides system inventory information, graphical UEFI Setup, platform update function, RAID Setup wizard, operating system installation function, and diagnostic functions.
- Support for Lenovo XClarity Energy Manager which captures real-time power and temperature data from the server and provides automated controls to lower energy costs.
- Integrated Trusted Platform Module (TPM) 2.0 support enables advanced cryptographic functionality, such as digital signatures and remote attestation.
- Supports Secure Boot to ensure that only a digitally signed operating system can be used. Supported with HDDs and SSDs as well as M.2 drives in the M.2 Adapter.
- Industry-standard Advanced Encryption Standard (AES) NI support for faster, stronger encryption.
- Intel Execute Disable Bit functionality can prevent certain classes of malicious buffer overflow attacks when combined with a supported operating system.
- Intel Trusted Execution Technology provides enhanced security through hardware-based resistance to malicious software attacks, allowing an application to run in its own isolated space, protected from all other software running on a system.

Energy efficiency

The SR950 offers the following energy-efficiency features to save energy, reduce operational costs, and increase energy availability:

- The server can be used in environments up to ASHRAE A4 with ambient temperatures up to 45 °C.
- The server is Energy Star 2.1 compliant
- Energy-efficient planar components help lower operational costs.
- High-efficiency power supplies with 80 PLUS Platinum certifications
- Intel Intelligent Power Capability powers individual processor elements on and off as needed, to reduce energy draw.
- Low-voltage 1.2 V DDR4 memory offers energy savings compared to 1.35 V and 1.5 V DDR3 DIMMs.
- Solid-state drives (SSDs) consume as much as 80% less power than mechanical 2.5-inch HDDs.
- The server uses hexagonal ventilation holes, which can be grouped more densely than round holes, providing more efficient airflow through the system.
- Optional Lenovo XClarity Energy Manager provide advanced data center power notification, analysis, and policy-based management to help achieve lower heat output and reduced cooling needs.

Components and connectors

The following figure shows the front of the SR950 server.

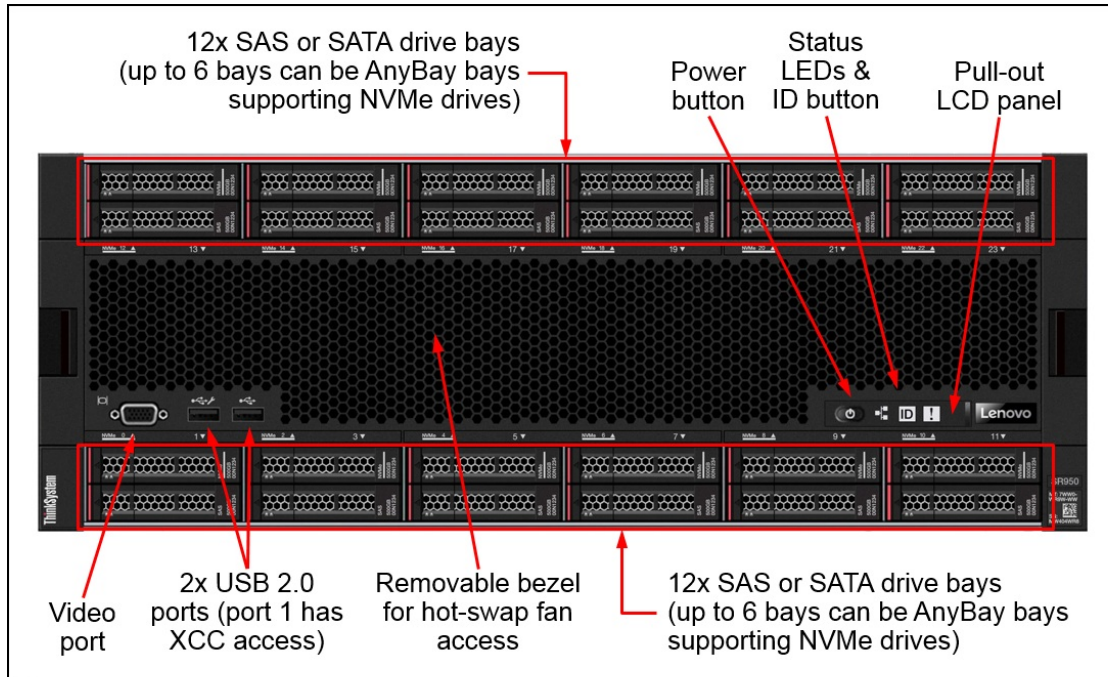

Figure 2. Front view of the Lenovo ThinkSystem SR950

The following figure shows the rear of the SR950 server. The server has up to 17 PCIe slots, depending on the riser cards selected and the number of processors installed.

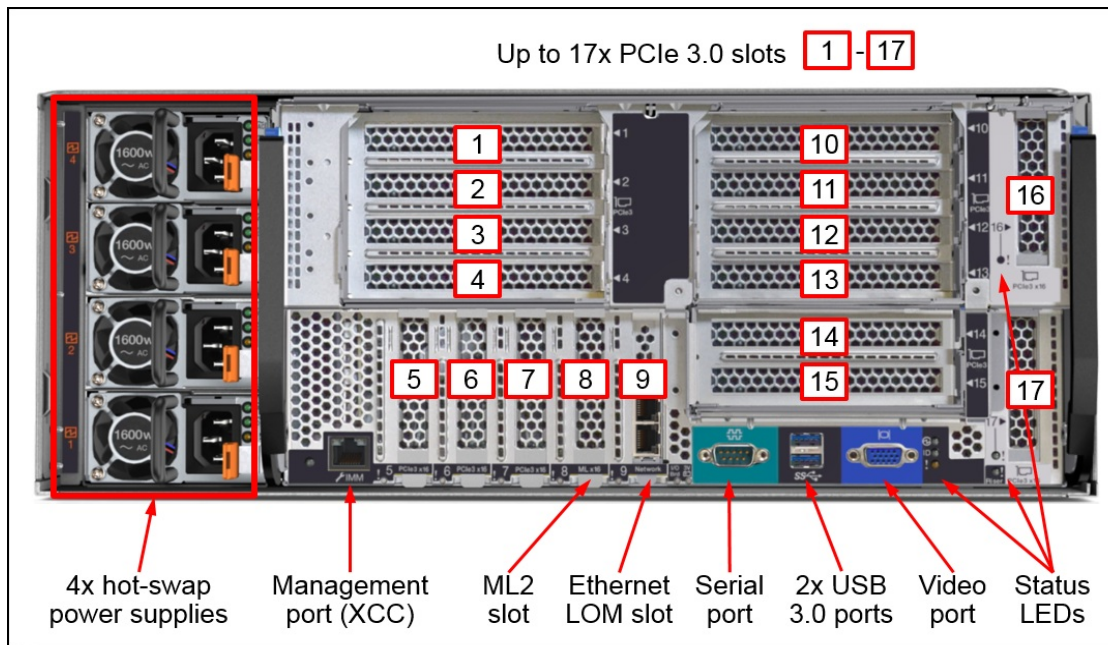

Figure 3. Rear view of the Lenovo ThinkSystem SR950

The processors and other components are located on compute trays, the Upper Compute Tray and the Lower Compute Tray. Each compute tray holds up to four processors on two system boards. The compute trays are accessible from the front of the server, as shown in the following figure.

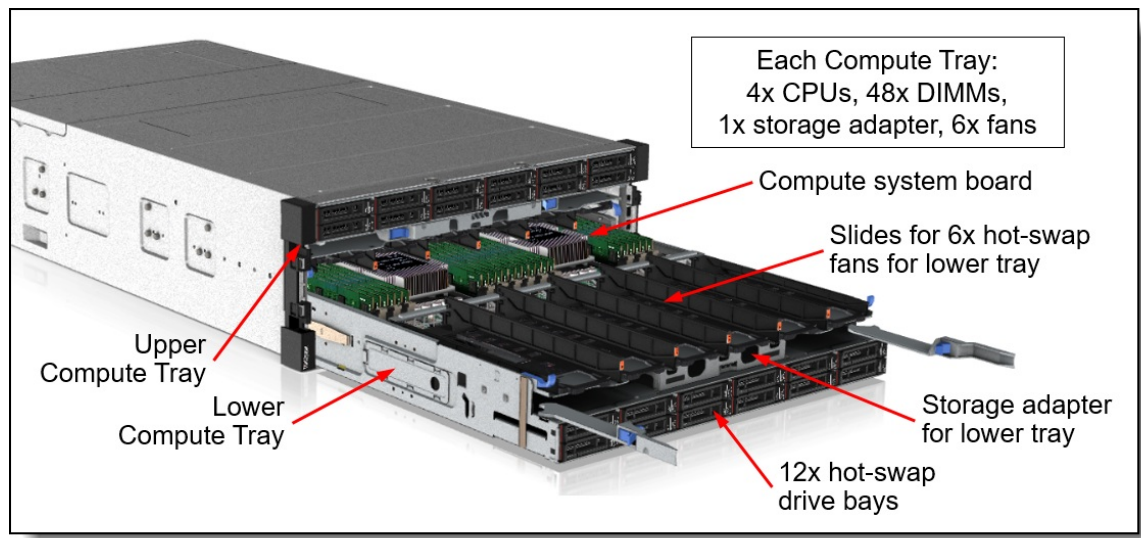

Figure 4. Lower Compute Tray partially removed

The server has one or two compute trays. Each compute tray contains:

- One or two compute system boards, each comprising:
 - Two processors
 - 24 DIMMs
- Six hot-swap fans, accessible even when the compute tray is installed
- 12x 2.5-inch hot-swap drive bays
- One PCIe slot reserved for a RAID adapter for internal SAS/SATA drives

The following figure shows the rear of the compute tray with its two compute system boards, one of them removed.

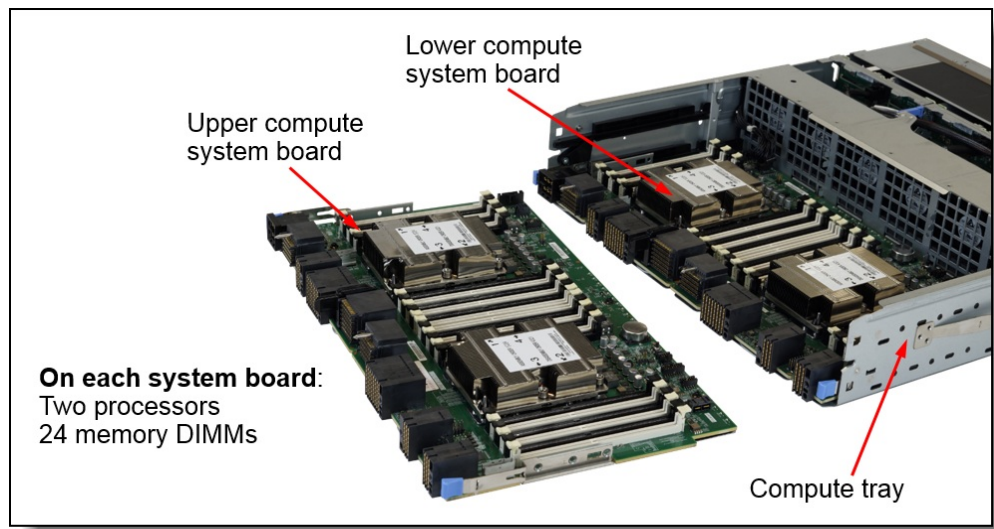

Figure 5. Compute tray with two compute system boards

The compute system board is shown in the following figure. Each system board holds two processors and 24 DIMM sockets, 12 per processor. The system board also has connections for the NVMe ports used to connect to the PCIe NVMe drive bays at the front of the server.

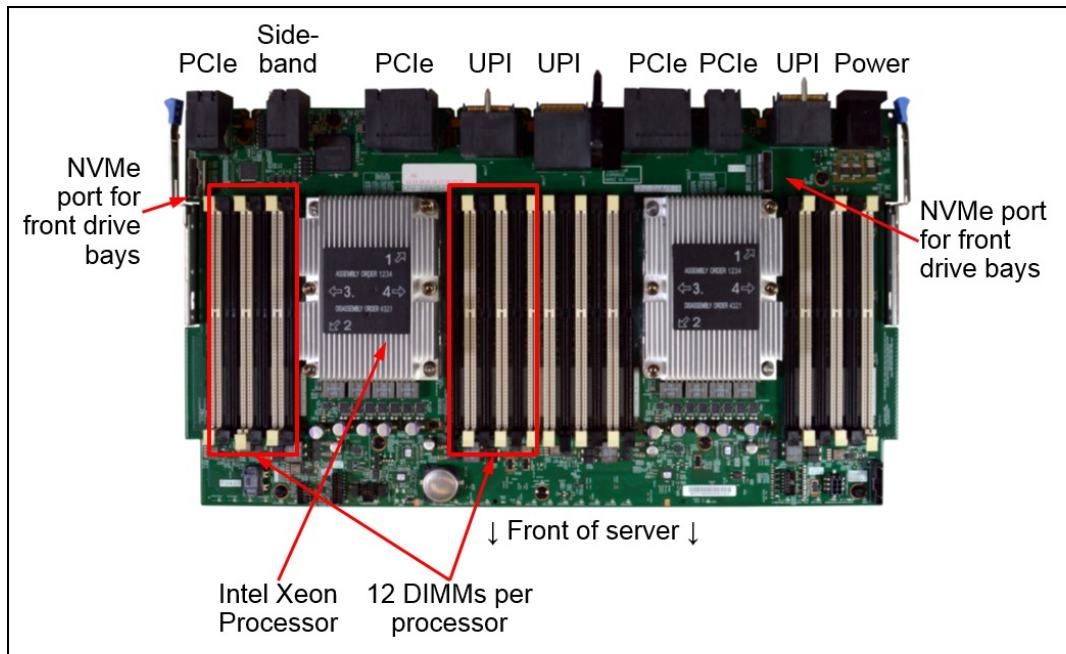

Figure 6. Compute system board

Processors installed in the compute system boards are numbered as shown in the following figure.

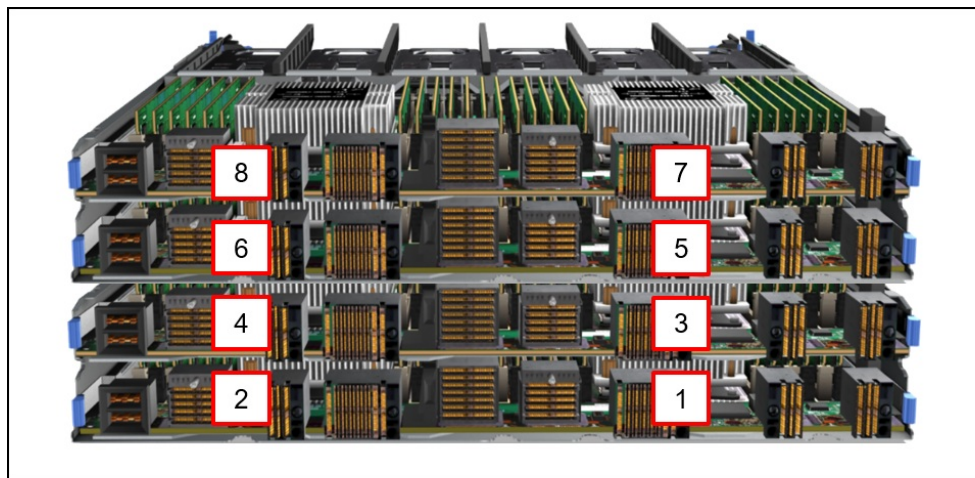

Figure 7. Processor numbering (viewed from the rear of the compute trays)

For some four-socket storage-rich configurations, a storage tray is used in the upper tray area instead of a compute tray. The following figure shows the key components of the storage tray.

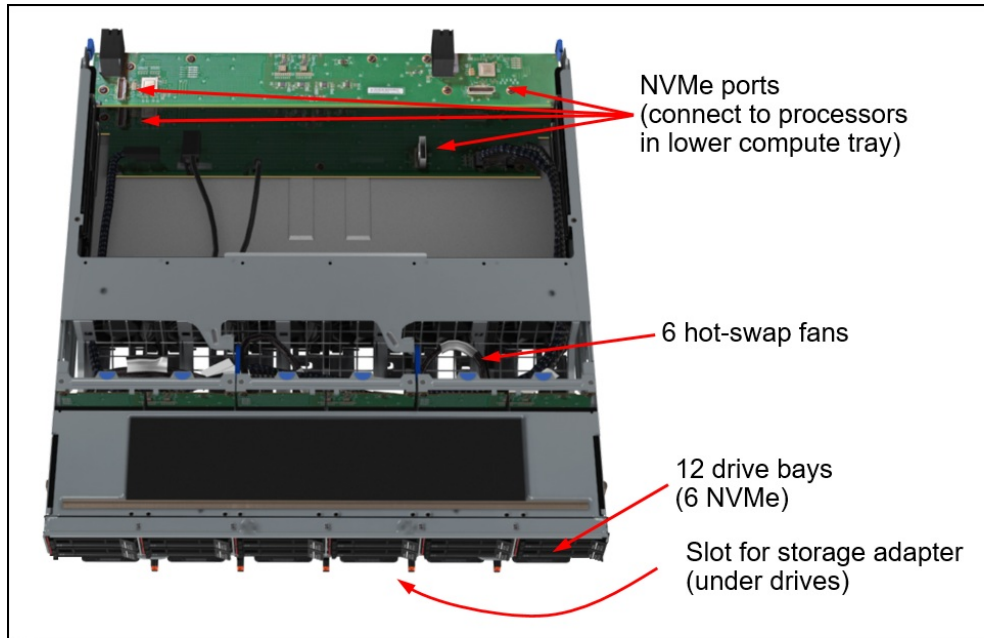

Figure 8. Storage tray

All slots and ports at the rear of the server are housed in the I/O tray as shown in the following figure.

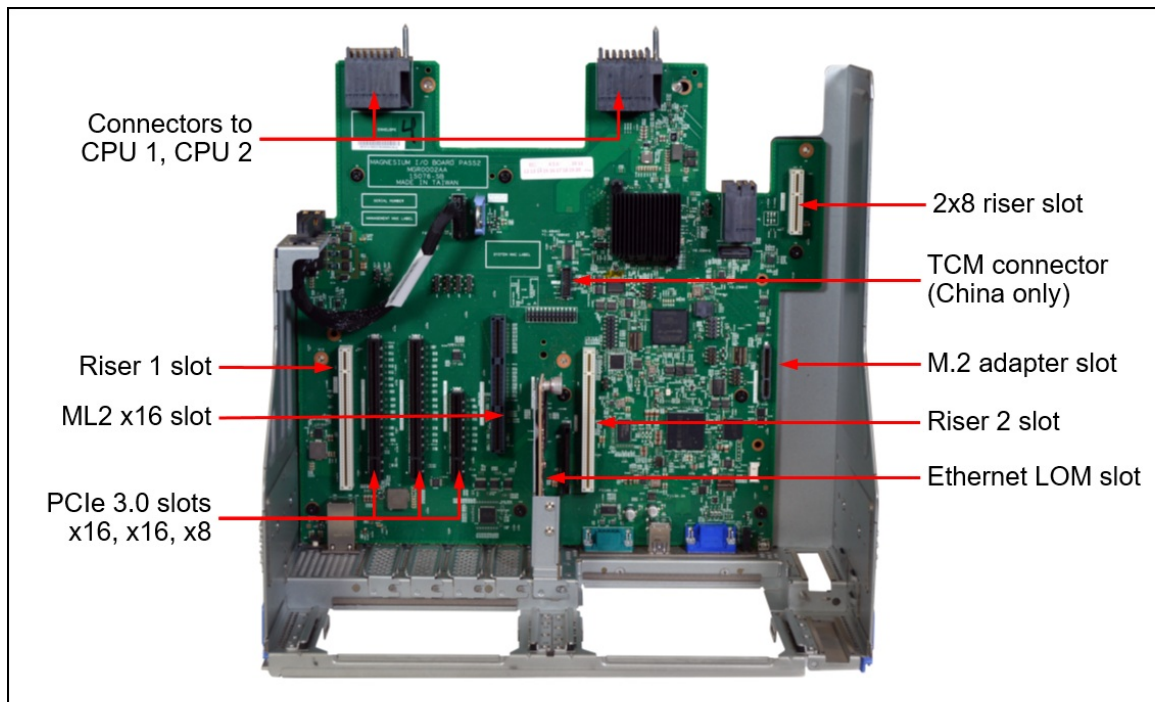

Figure 9. I/O tray

Server configurations

The SR950 supports five different configurations, depending on the desired number of processors, drive bays, PCIe slots, and upgradability to an 8-socket configuration.

Notes:

- The configurations listed here represent Lenovo's recommendations regarding the selection of compute system boards, I/O riser cards, and NVMe drive bays to maximize the available resources. You can select fewer drives and lower slot counts by using lower-slot-count riser cards to meet application requirements.
- Configurations 1 and 3 support the use of only two processors. This will reduce the available I/O slots and NVMe drive bays. This is described in details in the [Internal storage](#) section and the [I/O expansion options](#) section.
- Configuration 1 supports either two or four processors however the use 5100 Series processors requires that four processors be selected. Two 5100 Series processors are not supported in Configuration 1.
- Configurations 3 and 4 are designed to be upgradable to 8 processors. As a result, 8100 Series processors are required.

Table 1. Server configurations

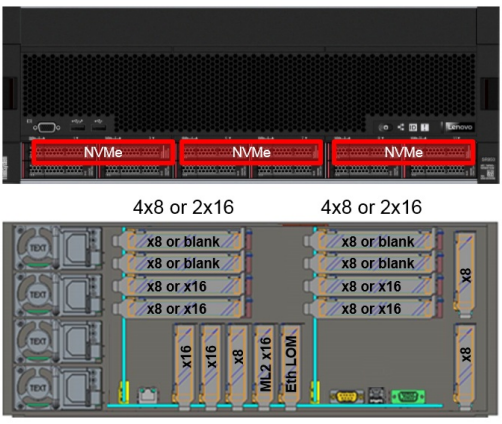
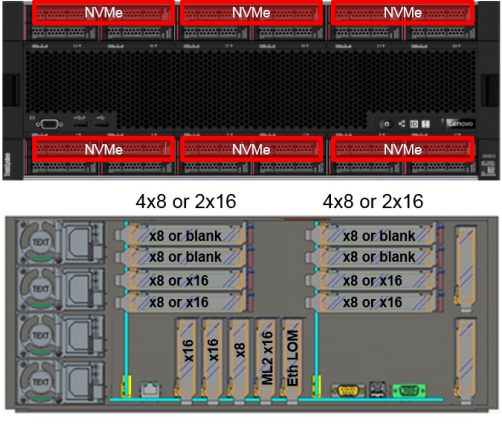
	<p>Configuration 1. Four-Socket Performance</p> <p>The highest-performing 4-socket server, at the lowest cost when up to 12 drives is enough and without the need to upgrade to 8 socket.</p> <ul style="list-style-type: none"> • 2 or 4 processors (if using 5100 Series processors, 4 processors must be selected) • 4 sockets configured in mesh topology for best performance • 12 drive bays (including up to 6 NVMe) • Filler installed in the upper tray area • <i>Not</i> upgradable to 8-socket
	<p>Configuration 2. Four-Socket Performance/ Storage Rich</p> <p>The highest-performing 4-socket server, when needing more than 12 drives without the need to upgrade to 8 socket.</p> <ul style="list-style-type: none"> • Requires 4 processors • 4 processors configured in mesh topology for best performance • 24 drives (including up to 12 NVMe) • Storage tray installed in the upper tray area • <i>Not</i> upgradable to 8-socket

<p>Filler tray</p> <p>Compute tray</p> <p>4x8 or 2x16 4x8 or 2x16</p> <p>2x8 riser</p>	<p>Configuration 3. Four-Socket Upgradable</p> <p>The lowest-cost 4-socket server capable of being upgraded to 8 socket and when 12 drive bays with 4 processors is enough storage.</p> <ul style="list-style-type: none"> • 2 or 4 processors, must be 8100 Series processors • 4 processors in a ring topology • 12 drive bays (including up to 6 NVMe) • Filler installed in the upper tray area • Upgradable to 8-socket with an additional compute tray and two system boards • Once upgraded, the system will have 24 drive bays
<p>Compute tray</p> <p>Compute tray</p> <p>5x16+ML2 5x16+ML2</p> <p>2x8 riser</p>	<p>Configuration 4. Four-Socket Upgradable / Storage Rich</p> <p>4-socket server capable of being upgraded to 8-socket and needing more than 12 drive bays with 4 processors.</p> <ul style="list-style-type: none"> • Requires 4 processors, must be 8100 Series • 4 processors in a ring topology • 24 drive bays (including up to 4 NVMe) • Two compute trays, with one system board in each tray • Upgradable to 8-socket with two additional system boards • Once upgraded, the server will support 12 NVMe drives.
<p>Compute tray</p> <p>Compute tray</p> <p>5x16+ML2 5x16+ML2</p> <p>2x8 riser</p>	<p>Configuration 5. Eight-Socket Storage Rich</p> <p>Full featured 8-socket server with up to 24 drive bays and the maximum number of PCIe x16 slots.</p> <ul style="list-style-type: none"> • Requires 8 processors, must be 8100 Series • 24 drive bays (including 12 NVMe) • Two compute trays each with two system boards

The following table summarizes the configurations.

Table 2. SR950 server configurations

Configuration	Supported processors	Lower Tray	Upper Tray	Processor Topology	Maximum storage	Maximum PCIe slots	Upgrade to 8S?
4S Performance	2 or 4 Any processor†	Compute Tray	Filler	4S Mesh*	12 drives (6 NVMe)	15	No
4S Performance/ Storage Rich	4 Any processor	Compute Tray	Storage Tray	4S Mesh*	24 drives (12 NVMe)	15	No
4S Upgradable	2 or 4 8100 Series only	Compute Tray	Filler	4S Ring	12 drives (6 NVMe)	15	Yes**
4S Upgradable/ Storage Rich	4 8100 Series only	Compute Tray with 1 system board	Compute Tray with 1 system board	4S Ring	24 drives (4 NVMe)	10	Yes**
8S Storage Rich	8 8100 Series only	Compute Tray	Compute Tray	8S	24 drives (12 NVMe)	17	Not applicable

† If using 5100 Series processors, then 4 processors must be selected. Using two 5100 Series processors is not supported.

* Mesh topology requires a processor with 3 UPI connections; Processors such as the 5100 series with only 2 UPI connections will operate in Ring topology. See the table in the [Processor options](#) section.

** After upgrade, maximum storage will be 24 drives (12 NVMe) and up to 17 total PCIe slots available (may require replacement riser cards)

For details about PCIe slot availability, see the [I/O expansion options](#) section.

Standard specifications

The following table lists the standard specifications.

Table 3. Standard specifications

Components	Specification
Machine type	7X11 - 1-year warranty 7X12 - 3-year warranty 7X13 - SAP HANA configurations with 3-year warranty
Form factor	4U rack
Processor	Up to eight Intel Xeon Processor Scalable Family of processors, either Gold or Platinum level processors (formerly codename "Skylake"). Supports processors with up to 28 cores, core speeds up to 3.6 GHz, and TDP ratings up to 205W. Processors and memory are located on system boards installed in compute trays: 2 processors per system board, 2 system boards per compute tray, and 2 compute trays in the server.
Chipset	Intel C624 chipset (formerly codename "Lewisburg")
Memory	Up to 96 DIMM sockets (12 DIMMs per processor, installed on each system board). Lenovo TruDDR4 RDIMMs, LRDIMMs and 3DS RDIMMs are supported. Each processor has 6 memory channels, with 2 DIMMs per channel

Components	Specification
Memory maximums	<p>With RDIMMs: Up to 3 TB with 96x 32 GB RDIMMs and eight processors With LRDIMMs: Up to 6 TB with 96x 64 GB LRDIMMs and eight processors With 3DS RDIMMs: Up to 12 TB with 96x 128 GB 3DS RDIMMs and eight processors</p> <p>Note: Support of more than 768 GB per processor (more than 3 TB for a 4-processor system or 6 TB for an 8-processor system) requires M-suffix processors with 1.5 TB memory support. See the Processor options section for information.</p>
Memory protection	ECC, Chipkill, Adaptive double-device data correction (ADDDC), memory mirroring, and memory rank sparing.
Disk drive bays	Up to 24x 2.5" hot-swap SAS/SATA drive bays. With AnyBay backplanes, 12 bays can be configured to support PCIe NVMe drives.
Maximum internal storage	<p>Up to 184.3 TB with 24x 7.68 TB 2.5-inch SAS SSDs or Up to 48 TB with 24x 2 TB 2.5-inch NL SAS HDDs</p>
Storage controller	<ul style="list-style-type: none"> • No embedded RAID • 12 Gb SAS/SATA RAID adapters: <ul style="list-style-type: none"> ◦ RAID 530i (cacheless) supports RAID 0, 1, 10, 5, 50 ◦ RAID 730-8i (China only) with 1GB cache supports RAID 0, 1, 10, 5, 50 ◦ RAID 930-8i with 2GB flash-backed cache supports RAID 0, 1, 10, 5, 50, 6, 60 ◦ RAID 930-16i with 4GB flash-backed cache supports RAID 0, 1, 10, 5, 50, 6, 60 • 12 Gb SAS/SATA non-RAID: 430-8i and 430-16i HBAs
Optical and tape bays	No internal bays.
Network interfaces	Integrated 10Gb Ethernet controller, based on the Intel Ethernet Connection X722. The server supports 1 of 6 available LOM adapters, providing either 2- or 4-port Gigabit Ethernet, 2- or 4-port 10 GbE with SFP+ connections or 2- or 4-port 10 GbE with RJ45 connections. One port can optionally be shared with the XClarity Controller (XCC) management processor for Wake-on-LAN and NC-SI support. 1 or 2 ML2 adapter slots for additional network adapters.

Components	Specification
PCI Expansion slots	<p>Up to 17 PCIe 3.0 rear-accessible slots:</p> <ul style="list-style-type: none"> • Slots 1-4 on a riser, one of: <ul style="list-style-type: none"> ◦ Riser with 4x PCIe 3.0 x16 slots, all full-height half-length, all 75W ◦ Riser with 2x PCIe 3.0 x16 slots, all full-height half-length, both 75W ◦ Riser with 4x PCIe 3.0 x8 slots, full-height half-length, all 75W • Slot 5: PCIe 3.0 x16, low-profile, 75W • Slot 6: PCIe 3.0 x16, low-profile, 75W • Slot 7: PCIe 3.0 x8, low-profile, 75W • Slot 8: PCIe 3.0 x16 ML2, low-profile (supports NC-SI) • Slot 9: PCIe 3.0 x8 LOM adapter slot, low-profile (supports NC-SI) • Slots 10-15 on a riser, one of: <ul style="list-style-type: none"> ◦ Riser 5x16+ML2: <ul style="list-style-type: none"> ▪ Five PCIe 3.0 x16 slots, all full-height half-length, all 75W ▪ One PCIe 3.0 x16 ML2 slot, full-height half-length, 30W (no NC-SI support) ◦ Riser 2x16: Two PCIe 3.0 x16 slots, all full-height half-length, both 75W ◦ Riser 4x8: Four PCIe 3.0 x8 slots, full-height half-length, all 75W • Slot 16-17 on a riser: <ul style="list-style-type: none"> ◦ PCIe 3.0 x8 low profile, 75W ◦ PCIe 3.0 x8 low profile, 75W <p>Additional internal PCIe slots:</p> <ul style="list-style-type: none"> • One or two PCIe 3.0 x8 slots for storage adapters • M.2 adapter slot
Ports	<p>Front: two USB 2.0 ports (one also for XCC local management), and one DB-15 VGA video port. Rear: two USB 3.0, one DB-15 VGA video, one DB-9 serial, and one 1 GbE RJ-45 systems management. The serial port can be shared with the XCC for serial redirection functions. Only one VGA port can be used at a time.</p>
Cooling	<p>Up to 12 redundant hot-swap single-rotor fans, 6 in each compute tray. Each tray has N+1 fan redundancy.</p>
Power supply	<p>Up to four redundant hot-swap 1100 W or 1600 W power supplies (80 PLUS Platinum certified), supporting 200-240 V AC input. The 1100 W power supply also supports 100-127V AC input supply with a reduced capacity of 1050 W. No support for 240 V DC.</p>
Hot-swap parts	<p>Drives, power supplies, and fans.</p>
Video	<p>G200 graphics with 16 MB memory with 2D hardware accelerator, integrated into the XClarity Controller. Maximum resolution is 1920x1200 32bpp at 60Hz.</p>
Security features	<p>Power-on password, administrator's password, Trusted Platform Module (TPM), supporting TPM 1.2 or TPM 2.0. In China only, optional Trusted Cryptographic Module (TCM).</p>
Systems management	<p>XClarity Controller embedded management, XClarity Administrator centralized infrastructure delivery, XClarity Integrator plugins, and XClarity Energy Manager centralized server power management. XClarity Controller Enterprise functionality standard with the SR950. Light path diagnostics for local failure detection and reporting, with LCD diagnostic pull-out panel.</p>
Operating systems	<p>Microsoft Windows Server 2012 R2, 2016; RHEL 6 & 7 x64; SLES 11 & 12 x64; VMware ESXi 6.0, 6.5. See the Supported operating systems section for details.</p>
Limited warranty	<p>One year or three-year (model dependent) customer-replaceable unit (CRU) and onsite limited warranty with 9x5 next business day (NBD).</p>
Service and support	<p>Optional service upgrades are available through Lenovo Services: 4-hour or 2-hour response time, 6-hour fix time, 1-year or 2-year warranty extension, software support for Lenovo hardware and some third-party applications.</p>

Components	Specification
Dimensions	Height: 173 mm (6.8 in.); depth EIA flange to rear: 800.0 mm (31.5 in.), depth overall: 835.0 mm (32.9 in.); width across top cover: 447.0 mm (17.6 in.), width to EIA flanges: 482.0 mm (19.0 in.).
Weight	Minimum configuration: 32.6 kg (71.9 lb), Maximum configuration: 58.7 kg (129.4 lb)

The server is shipped with the following items:

- Rail kit
- Documentation flyer
- Power cords (model and region dependent)

Models

The following tables list the available models, grouped by region.

- [Models for Australia and New Zealand](#)
- [Models for South East Asian countries \(ASEAN\)](#)
- [Models for Brazil](#)
- [Models for Latin American countries \(except Brazil\)](#)
- [Models for EMEA countries](#)
- [Models for Hong Kong, Taiwan, Korea \(HTK\)](#)
- [Models for India](#)
- [Models for Japan](#)
- [Models for USA and Canada](#)

Refer to the Specifications section for information about standard features of the server.

Common to all models:

- All models include a rail kit.
- All models include 2.8m, 10A/100-250V, C13 to C14 Jumper Cords (one per installed power supply), with the exception of models for India, which include 2.8m, 10A/250V, C13 to IS 6538 Line Cords

Models for Australia and New Zealand

Table 4. Models for Australia and New Zealand

Model	Intel Xeon processors†	Compute trays	Memory	RAID	Drive bays	Drives	Ethernet LOM	Slots*	Power supplies
7X12 A00RAU	4x Gold 5120 14C 105W 2.2GHz	1	4x 32GB	1x RAID 930-8i	8x 2.5" (4x AnyBay)	Open	Open	11 (2,0,0,1)	2x 1600W HS
7X12 A00SAU	4x Gold 5120 14C 105W 2.2GHz	1	4x 32GB	1x RAID 930-8i	8x 2.5" (4x AnyBay)	Open	Open	11 (2,0,0,1)	2x 1600W HS
7X12 A00CAU	4x Gold 5120 14C 105W 2.2GHz	1	4x 32GB	1x RAID 930-8i	8x 2.5" (4x AnyBay)	Open	Open	11 (2,0,0,1)	2x 1600W HS
7X12 A00UAU	2x Gold 6130 16C 125W 2.1GHz	1	2x 32GB	1x RAID 930-8i	8x 2.5" (4x AnyBay)	Open	Open	5 (0,0,0,0)	2x 1100W HS
7X12 A00FAU	2x Gold 6130 16C 125W 2.1GHz	1	2x 32GB	1x RAID 930-8i	8x 2.5" (4x AnyBay)	Open	Open	5 (0,0,0,0)	2x 1100W HS
7X12 A00BAU	2x Gold 6130 16C 125W 2.1GHz	1	2x 32GB	1x RAID 930-8i	8x 2.5" (4x AnyBay)	Open	Open	5 (0,0,0,0)	2x 1100W HS
7X12 A00HAU	4x Platinum 8153 16C 125W 2.0GHz	1	4x 32GB	1x RAID 930-8i	8x 2.5" (4x AnyBay)	Open	Open	11 (2,0,0,1)	2x 1600W HS
7X12 A00LAU	4x Platinum 8153 16C 125W 2.0GHz	1	4x 32GB	1x RAID 930-8i	8x 2.5" (4x AnyBay)	Open	Open	11 (2,0,0,1)	2x 1600W HS
7X12 A00QAU	4x Platinum 8153 16C 125W 2.0GHz	1	4x 32GB	1x RAID 930-8i	8x 2.5" (4x AnyBay)	Open	Open	11 (2,0,0,1)	2x 1600W HS
7X12 A00EAU	8x Platinum 8160 24C 150W 2.1GHz	2	8x 32GB	2x RAID 930-16i	24x 2.5" (12x AnyBay)	Open	Open	17 (0,0,2,1)	4x 1600W HS
7X12 A00NAU	8x Platinum 8160 24C 150W 2.1GHz	2	8x 32GB	2x RAID 930-16i	24x 2.5" (12x AnyBay)	Open	Open	17 (0,0,2,1)	4x 1600W HS
7X12 A003AU	8x Platinum 8160 24C 150W 2.1GHz	2	8x 32GB	2x RAID 930-16i	24x 2.5" (12x AnyBay)	Open	Open	17 (0,0,2,1)	4x 1600W HS

† Processor detail: Quantity, model, core count, TDP, core frequency

* Values in brackets are numbers of riser cards: (A,B,C,D) where A=2x16 Riser, B=4x8 Riser, C=5x16+ML2 Riser, D=2x8 Riser

Models for South East Asian countries (ASEAN)

Table 5. Models for South East Asian countries (ASEAN)

Model	Intel Xeon processors†	Compute trays	Memory	RAID	Drive bays	Drives	Ethernet LOM	Slots*	Power supplies
7X12 A015SG	2x Platinum 8153 16C 125W 2.0GHz	1	4x 32GB	1x RAID 930-16i	12x 2.5" (6x AnyBay)	Open	4x10Gb RJ45	5 (0,0,0,0)	2x 1600W HS
7X12 A016SG	2x Platinum 8158 12C 150W 3.0GHz	1	4x 32GB	1x RAID 930-16i	12x 2.5" (6x AnyBay)	Open	4x10Gb RJ45	5 (0,0,0,0)	2x 1600W HS
7X12 A014SG	2x Platinum 8160 24C 150W 2.1GHz	1	4x 32GB	1x RAID 930-16i	12x 2.5" (6x AnyBay)	Open	4x10Gb RJ45	5 (0,0,0,0)	2x 1600W HS
7X12 A01BSG	2x Platinum 8164 26C 150W 2.0GHz	1	4x 32GB	1x RAID 930-16i	12x 2.5" (6x AnyBay)	Open	4x10Gb RJ45	5 (0,0,0,0)	2x 1600W HS
7X12 A01CSG	2x Platinum 8176 28C 165W 2.1GHz	1	4x 32GB	1x RAID 930-16i	12x 2.5" (6x AnyBay)	Open	4x10Gb RJ45	5 (0,0,0,0)	2x 1600W HS

† Processor detail: Quantity, model, core count, TDP, core frequency

* Values in brackets are numbers of riser cards: (A,B,C,D) where A=2x16 Riser, B=4x8 Riser, C=5x16+ML2 Riser, D=2x8 Riser

Models for Brazil

Table 6. Models for Brazil

Model	Intel Xeon processors†	Compute trays	Memory	RAID	Drive bays	Drives	Ethernet LOM	Slots*	Power supplies
7X12 A01WBR	4x Gold 5120 14C 105W 2.2GHz	1	4x 32GB	1x RAID 930-8i	8x 2.5" (4x AnyBay)	Open	Open	11 (2,0,0,1)	2x 1600W HS
7X12 A01TBR	2x Gold 6130 16C 125W 2.1GHz	1	2x 32GB	1x RAID 930-8i	8x 2.5" (4x AnyBay)	Open	Open	5 (0,0,0,0)	2x 1100W HS
7X12 A01VBR	4x Platinum 8153 16C 125W 2.0GHz	1	4x 32GB	1x RAID 930-8i	8x 2.5" (4x AnyBay)	Open	Open	11 (2,0,0,1)	2x 1600W HS
7X12 A01UBR	8x Platinum 8160 24C 150W 2.1GHz	2	8x 32GB	2x RAID 930-16i	24x 2.5" (12x AnyBay)	Open	Open	17 (0,0,2,1)	4x 1600W HS

† Processor detail: Quantity, model, core count, TDP, core frequency

* Values in brackets are numbers of riser cards: (A,B,C,D) where A=2x16 Riser, B=4x8 Riser, C=5x16+ML2 Riser, D=2x8 Riser

Models for Latin American countries (except Brazil)

Table 7. Models for Latin American countries (except Brazil)

Model	Intel Xeon processors†	Compute trays	Memory	RAID	Drive bays	Drives	Ethernet LOM	Slots*	Power supplies
7X12 A020LA	4x Platinum 8170 26C 165W 2.1GHz	2	24x 16GB 2Rx8	2x RAID 930-16i	24x 2.5" (8x AnyBay)	Open	4x10Gb SFP+	11 (0,0,1,0)	4x 1600W HS
7X12 A01ZLA	4x Platinum 8176 28C 165W 2.1GHz	2	24x 32GB	2x RAID 930-16i	24x 2.5" (8x AnyBay)	Open	4x10Gb SFP+	11 (0,0,1,0)	4x 1600W HS
7X12 A01YLA	4x Platinum 8176 28C 165W 2.1GHz	2	24x 16GB 2Rx8	2x RAID 930-16i	24x 2.5" (8x AnyBay)	Open	4x10Gb SFP+	11 (0,0,1,0)	4x 1600W HS
7X12 A023LA	4x Platinum 8180 28C 205W 2.5GHz	2	24x 32GB	2x RAID 930-16i	24x 2.5" (8x AnyBay)	Open	4x10Gb SFP+	11 (0,0,1,0)	4x 1600W HS
7X12 A024LA	4x Platinum 8153 16C 125W 2.0GHz	2	24x 16GB 2Rx8	2x RAID 930-16i	24x 2.5" (8x AnyBay)	Open	4x10Gb SFP+	11 (0,0,1,0)	4x 1600W HS
7X12 A022LA	4x Platinum 8164 26C 150W 2.0GHz	2	24x 16GB 2Rx8	2x RAID 930-16i	24x 2.5" (8x AnyBay)	Open	4x10Gb SFP+	11 (0,0,1,0)	4x 1600W HS
7X12 A021LA	8x Platinum 8180M 28C 205W 2.5GHz	2	48x 32GB	2x RAID 930-16i	24x 2.5" (8x AnyBay)	Open	4x10Gb SFP+	11 (0,0,1,0)	4x 1600W HS
7X12 A025LA	4x Platinum 8180 28C 205W 2.5GHz	2	24x 16GB 2Rx8	2x RAID 930-16i	24x 2.5" (8x AnyBay)	Open	4x10Gb SFP+	11 (0,0,1,0)	4x 1600W HS

† Processor detail: Quantity, model, core count, TDP, core frequency

* Values in brackets are numbers of riser cards: (A,B,C,D) where A=2x16 Riser, B=4x8 Riser, C=5x16+ML2 Riser, D=2x8 Riser

Models for EMEA countries

Table 8. Models for EMEA countries

Model	Intel Xeon processors†	Compute trays	Memory	RAID	Drive bays	Drives	Ethernet LOM	Slots*	Power supplies
7X12 A019EA	4x Gold 5120 14C 105W 2.2GHz	1	4x 32GB	1x RAID 930-16i	12x 2.5"	Open	Open	11 (2,0,0,1)	2x 1600W HS
7X12 A01AEA	2x Gold 6130 16C 125W 2.1GHz	1	2x 32GB	1x RAID 930-8i	8x 2.5" (4x AnyBay)	Open	Open	5 (0,0,0,0)	2x 1600W HS
7X12 A018EA	4x Platinum 8153 16C 125W 2.0GHz	1	4x 32GB	1x RAID 930-16i	12x 2.5"	Open	Open	11 (2,0,0,1)	2x 1600W HS
7X12 A017EA	8x Platinum 8160 24C 150W 2.1GHz	2	8x 32GB	2x RAID 930-16i	24x 2.5"	Open	Open	17 (0,0,2,1)	4x 1600W HS

† Processor detail: Quantity, model, core count, TDP, core frequency

* Values in brackets are numbers of riser cards: (A,B,C,D) where A=2x16 Riser, B=4x8 Riser, C=5x16+ML2 Riser, D=2x8 Riser

Models for Hong Kong, Taiwan, Korea (HTK)

Table 9. Models for Hong Kong, Taiwan, Korea (HTK)

Model	Intel Xeon processors†	Compute trays	Memory	RAID	Drive bays	Drives	Ethernet LOM	Slots*	Power supplies
7X12 A01KCN	2x Gold 6130 16C 125W 2.1GHz	1	2x 16GB 2Rx8	1x RAID 930-16i	12x 2.5" (6x AnyBay)	Open	4x1Gb	5 (0,0,0,0)	2x 1600W HS
7X12 A01RCN	2x Gold 6140 18C 140W 2.3GHz	1	2x 16GB 2Rx8	1x RAID 930-16i	12x 2.5" (6x AnyBay)	Open	4x1Gb	5 (0,0,0,0)	2x 1600W HS
7X12 A01PCN	2x Gold 6142 16C 150W 2.6GHz	1	2x 16GB 2Rx8	1x RAID 930-16i	12x 2.5" (6x AnyBay)	Open	4x1Gb	5 (0,0,0,0)	2x 1600W HS
7X12 A01NCN	2x Gold 6148 20C 150W 2.4GHz	1	2x 16GB 2Rx8	1x RAID 930-16i	12x 2.5" (6x AnyBay)	Open	4x1Gb	5 (0,0,0,0)	2x 1600W HS
7X12 A01LCN	2x Gold 6152 22C 140W 2.1GHz	1	2x 16GB 2Rx8	1x RAID 930-16i	12x 2.5" (6x AnyBay)	Open	4x1Gb	5 (0,0,0,0)	2x 1600W HS
7X12 A01JCN	2x Platinum 8153 16C 125W 2.0GHz	1	2x 16GB 2Rx8	1x RAID 930-16i	12x 2.5" (6x AnyBay)	Open	4x1Gb	5 (0,0,0,0)	2x 1600W HS
7X12 A01HCN	2x Platinum 8156 4C 105W 3.6GHz	1	2x 16GB 2Rx8	1x RAID 930-16i	12x 2.5" (6x AnyBay)	Open	4x1Gb	5 (0,0,0,0)	2x 1600W HS
7X12 A01QCN	2x Platinum 8160 24C 150W 2.1GHz	1	2x 16GB 2Rx8	1x RAID 930-16i	12x 2.5" (6x AnyBay)	Open	4x1Gb	5 (0,0,0,0)	2x 1600W HS
7X12 A01FCN	2x Platinum 8170 26C 165W 2.1GHz	1	2x 16GB 2Rx8	1x RAID 930-16i	12x 2.5" (6x AnyBay)	Open	4x1Gb	5 (0,0,0,0)	2x 1600W HS
7X12 A01ECN	2x Platinum 8180 28C 205W 2.5GHz	1	2x 16GB 2Rx8	1x RAID 930-16i	12x 2.5" (6x AnyBay)	Open	4x1Gb	5 (0,0,0,0)	2x 1600W HS

† Processor detail: Quantity, model, core count, TDP, core frequency

* Values in brackets are numbers of riser cards: (A,B,C,D) where A=2x16 Riser, B=4x8 Riser, C=5x16+ML2 Riser, D=2x8 Riser

Models for India

Table 10. Models for India

Model	Intel Xeon processors†	Compute trays	Memory	RAID	Drive bays	Drives	Ethernet LOM	Slots*	Power supplies
7X12 A00VSG	2x Gold 6126 12C 125W 2.6GHz	1	2x 16GB 1Rx4	1x RAID 930-16i	4x 2.5" (2x AnyBay)	Open	4x1Gb	5 (0,0,0,0)	2x 1100W HS
7X12 A002SG	2x Gold 6132 14C 140W 2.6GHz	1	2x 16GB 1Rx4	1x RAID 930-16i	4x 2.5" (2x AnyBay)	Open	4x1Gb	5 (0,0,0,0)	2x 1100W HS
7X12 A008SG	2x Gold 6140 18C 140W 2.3GHz	1	2x 16GB 1Rx4	1x RAID 930-16i	4x 2.5" (2x AnyBay)	Open	4x1Gb	5 (0,0,0,0)	2x 1100W HS
7X12 A004SG	2x Gold 6142 16C 150W 2.6GHz	1	2x 16GB 1Rx4	1x RAID 930-16i	4x 2.5" (2x AnyBay)	Open	4x1Gb	5 (0,0,0,0)	2x 1100W HS
7X12 A00ASG	2x Gold 6148 20C 150W 2.4GHz	1	2x 16GB 1Rx4	1x RAID 930-16i	4x 2.5" (2x AnyBay)	Open	4x1Gb	5 (0,0,0,0)	2x 1100W HS
7X12 A009SG	2x Gold 6150 18C 165W 2.7GHz	1	2x 16GB 1Rx4	1x RAID 930-16i	4x 2.5" (2x AnyBay)	Open	4x1Gb	5 (0,0,0,0)	2x 1100W HS
7X12 A005SG	2x Gold 6152 22C 140W 2.1GHz	1	2x 16GB 1Rx4	1x RAID 930-16i	4x 2.5" (2x AnyBay)	Open	4x1Gb	5 (0,0,0,0)	2x 1100W HS
7X12 A00PSG	2x Platinum 8158 12C 150W 3.0GHz	1	2x 16GB 1Rx4	1x RAID 930-16i	4x 2.5" (2x AnyBay)	Open	4x1Gb	5 (0,0,0,0)	2x 1100W HS
7X12 A011SG	2x Platinum 8164 26C 150W 2.0GHz	1	2x 16GB 1Rx4	1x RAID 930-16i	4x 2.5" (2x AnyBay)	Open	4x1Gb	5 (0,0,0,0)	2x 1100W HS
7X12 A00YSG	2x Platinum 8180 28C 205W 2.5GHz	1	2x 16GB 1Rx4	1x RAID 930-16i	4x 2.5" (2x AnyBay)	Open	4x1Gb	5 (0,0,0,0)	2x 1100W HS
7X12 A00JSG	2x Gold 6134M 8C 130W 3.2GHz	1	2x 16GB 1Rx4	1x RAID 930-16i	4x 2.5" (2x AnyBay)	Open	4x1Gb	5 (0,0,0,0)	2x 1100W HS
7X12 A00KSG	2x Gold 6134M 8C 130W 3.2GHz	1	2x 32GB	1x RAID 930-16i	4x 2.5" (2x AnyBay)	Open	4x1Gb	5 (0,0,0,0)	2x 1100W HS
7X12 A006SG	2x Gold 6140M 18C 140W 2.3GHz	1	2x 16GB 1Rx4	1x RAID 930-16i	4x 2.5" (2x AnyBay)	Open	4x1Gb	5 (0,0,0,0)	2x 1100W HS
7X12 A010SG	2x Gold 6142M 16C 150W 2.6GHz	1	2x 16GB 1Rx4	1x RAID 930-16i	4x 2.5" (2x AnyBay)	Open	4x1Gb	5 (0,0,0,0)	2x 1100W HS
7X12 A001SG	2x Gold 6142M 16C 150W 2.6GHz	1	2x 32GB	1x RAID 930-16i	4x 2.5" (2x AnyBay)	Open	4x1Gb	5 (0,0,0,0)	2x 1100W HS
7X12 A00ZSG	2x Platinum 8160M 24C 150W 2.1GHz	1	2x 32GB	1x RAID 930-16i	4x 2.5" (2x AnyBay)	Open	4x1Gb	5 (0,0,0,0)	2x 1100W HS
7X12 A00DSG	2x Platinum 8160M 24C 150W 2.1GHz	1	2x 16GB 1Rx4	1x RAID 930-16i	4x 2.5" (2x AnyBay)	Open	4x1Gb	5 (0,0,0,0)	2x 1100W HS

† Processor detail: Quantity, model, core count, TDP, core frequency

* Values in brackets are numbers of riser cards: (A,B,C,D) where A=2x16 Riser, B=4x8 Riser, C=5x16+ML2 Riser, D=2x8 Riser

Models for Japan

Table 11. Models for Japan

Model	Intel Xeon processors†	Compute trays	Memory	RAID	Drive bays	Drives	Ethernet LOM	Slots*	Power supplies
7X12 A00MJP	2x Gold 6128 6C 115W 3.4GHz	1	4x 16GB 1Rx4	1x RAID 930-16i	4x 2.5"	Open	4x10Gb RJ45	7 (0,0,0,1)	4x 1100W HS
7X12 A013JP	2x Gold 6154 18C 200W 3.0GHz	1	2x 16GB 1Rx4	1x RAID 930-16i	8x 2.5" (2x AnyBay)	Open	4x10Gb RJ45	7 (0,0,0,1)	2x 1600W HS
7X12 A012JP	4x Platinum 8180 28C 205W 2.5GHz	1	4x 16GB 1Rx4	1x RAID 930-16i	4x 2.5"	Open	4x10Gb RJ45	7 (0,0,0,1)	4x 1600W HS

† Processor detail: Quantity, model, core count, TDP, core frequency

* Values in brackets are numbers of riser cards: (A,B,C,D) where A=2x16 Riser, B=4x8 Riser, C=5x16+ML2 Riser, D=2x8 Riser

Models for USA and Canada

Table 12. Models for USA and Canada

Model	Intel Xeon processors†	Compute trays	Memory	RAID	Drive bays	Drives	Ethernet LOM	Slots*	Power supplies
7X12 A01GNA	4x Gold 5120 14C 105W 2.2GHz	1	4x 32GB	1x RAID 930-8i	8x 2.5"	Open	Open	11 (2,0,0,1)	2x 1600W HS
7X12 A01DNA	2x Gold 6130 16C 125W 2.1GHz	1	2x 32GB	1x RAID 930-8i	8x 2.5" (2x AnyBay)	Open	Open	5 (0,0,0,0)	2x 1100W HS
7X12 A01MNA	4x Platinum 8153 16C 125W 2.0GHz	1	4x 32GB	1x RAID 930-8i	8x 2.5"	Open	Open	11 (2,0,0,1)	2x 1600W HS
7X12 A01SNA	8x Platinum 8160 24C 150W 2.1GHz	2	8x 32GB	2x RAID 930-16i	24x 2.5"	Open	Open	17 (0,0,2,1)	4x 1600W HS

† Processor detail: Quantity, model, core count, TDP, core frequency

* Values in brackets are numbers of riser cards: (A,B,C,D) where A=2x16 Riser, B=4x8 Riser, C=5x16+ML2 Riser, D=2x8 Riser

SAP HANA configurations

The Lenovo SR950 solutions for SAP HANA provide optimal solutions for SAP NetWeaver Business Warehouse, data mart, and SAP Business Suite, Powered by SAP HANA applications.

The following table lists the configurations available for SAP HANA (machine type 7X13)

Tip: Use the Configuration identifier listed in the table in the LESC configurator to load the pre-defined configuration.

Table 13. SAP HANA configurations

Memory	Config identifier	Config	Intel Xeon Processor	Memory configuration	Drives	RAID	Storage capacity	Network
All-flash configurations - 2 socket - standalone server								
192 GB	2SKL192 SSDS	Single node	2x 8176	192 GB (12x 16 GB)	2x 400GB SSD 3x 3.84TB SSD	1x 930-16i	7.6 TB RAID-5 data/log	4x 10GbE 4x 1GigE
384 GB	2SKL384 SSDS	Single node	2x 8176	384 GB (24x 16 GB or 12x 32 GB)	2x 400GB SSD 3x 3.84TB SSD	1x 930-16i	7.6 TB RAID-5 data/log	4x 10GbE 4x 1GigE

Memory	Config identifier	Config	Intel Xeon Processor	Memory configuration	Drives	RAID	Storage capacity	Network
768 GB	2SKL768 SSDS	Single node	2x 8176	768 GB (24x 32 GB or 12x 64 GB)	2x 400GB SSD 3x 3.84TB SSD	1x 930-16i	7.6 TB RAID-5 data/log	4x 10GbE 4x 1GigE
1,536 GB	2SKL1536 SSDS	Single node	2x 8176	1,536 GB (24x 64 GB or 12x 128 GB)	2x 400GB SSD 3x 3.84TB SSD	1x 930-16i	7.6 TB RAID-5 data/log	4x 10GbE 4x 1GigE
3,072 GB*	2SKL3072 SSDS	Single node	2x 8176M	3,072 GB (24x 128 GB)	2x 400GB SSD 5x 3.84TB SSD	1x 930-16i	15.3 TB RAID-5 data/log	4x 10GbE 4x 1GigE
All-flash configurations - 4 socket - standalone								
384 GB	4SKL384 SSDS	Single node	4x 8176	384 GB (24x 16 GB)	2x 400GB SSD 3x 3.84TB SSD	1x 930-16i	7.6 TB RAID-5 data/log	4x 10GbE 4x 1GigE
768 GB	4SKL768 SSDS	Single node	4x 8176	768 GB (48x 16 GB or 24x 32 GB)	2x 400GB SSD 3x 3.84TB SSD	1x 930-16i	7.6 TB RAID-5 data/log	4x 10GbE 4x 1GigE
1,536 GB	4SKL1536 SSDS	Single node	4x 8176	1,536 GB (48x 32 GB or 24x 64 GB)	2x 400GB SSD 3x 3.84TB SSD	1x 930-16i	7.6 TB RAID-5 data/log	4x 10GbE 4x 1GigE
3,072 GB	4SKL3072 SSDS	Single node	4x 8176	3,072 GB (48x 64 GB or 24x 128 GB)	2x 400GB SSD 5x 3.84TB SSD	1x 930-16i	15.3 TB RAID-5 data/log	4x 10GbE 4x 1GigE
6,144 GB*	4SKL6144 SSDS	Single node	4x 8176M	6,144 GB (48x 128 GB)	2x 400GB SSD 9x 3.84TB SSD	1x 930-16i	30.7 TB RAID-5 data/log	4x 10GbE 4x 1GigE
All-flash configurations - 8 socket - standalone								
768 GB	8SKL768 SSDS	Single node	8x 8176	768 GB (48x 16 GB)	2x 400GB SSD 3x 3.84TB SSD	1x 930-16i	7.6 TB RAID-5 data/log	4x 10GbE 4x 1GigE
1,536 GB	8SKL1536 SSDS	Single node	8x 8176	1,536 GB (96x 16 GB or 48x 32 GB)	2x 400GB SSD 3x 3.84TB SSD	1x 930-16i	7.6 TB RAID-5 data/log	4x 10GbE 4x 1GigE
3,072 GB	8SKL3072 SSDS	Single node	8x 8176	3,072 GB (96x 32 GB or 48x 64 GB)	2x 400GB SSD 5x 3.84TB SSD	1x 930-16i	15.3 TB RAID-5 data/log	4x 10GbE 4x 1GigE
6,144 GB	8SKL6144 SSDS	Single node	8x 8176	6,144 GB (96x 64 GB or 48x 128 GB)	2x 400GB SSD 9x 3.84TB SSD	1x 930-16i	30.7 TB RAID-5 data/log	4x 10GbE 4x 1GigE
12,288 GB*	8SKL12288 SSDS	Single node	8x 8176M	12,288 GB (96x 128 GB)	2x 400GB SSD 18x 3.84TB SSD or 9x 7.68TB SSD	2x 930-16i†	61.4 TB RAID-5 data/log	4x 10GbE 4x 1GigE
All-flash configurations - 4 socket - scaleout								
1,536 GB	4SKL1536 SSDG	Scaleout to 94 nodes	4x 8176	1,536 GB (48x 32 GB or 24x 64 GB)	2x 400GB SSD 5x 3.84TB SSD	1x 930-16i	15.3 TB RAID-5 data/log	4x 10GbE 4x 1GigE
3,072 GB	4SKL3072 SSDG	Scaleout to 94 nodes	4x 8176	3,072 GB (48x 64 GB or 24x 128 GB)	2x 400GB SSD 9x 3.84TB SSD	1x 930-16i	30.7 TB RAID-5 data/log	4x 10GbE 4x 1GigE
All-flash configurations - 8 socket - scaleout								
3,072 GB	8SKL3072 SSDG	Scaleout to 94 nodes	8x 8176	3,072 GB (96x 32 GB or 48x 64 GB)	2x 400GB SSD 9x 3.84TB SSD	1x 930-16i	30.7 TB RAID-5 data/log	4x 10GbE 4x 1GigE

Memory	Config identifier	Config	Intel Xeon Processor	Memory configuration	Drives	RAID	Storage capacity	Network
6,144 GB**	8SKL6144 SSDG	Scaleout to 94 nodes	8x 8176	6,144 GB (96x 64 GB or 48x 128 GB)	2x 400GB SSD 18x 3.84TB SSD or 9x 7.68TB SSD	2x 930-16i†	61.4 TB RAID-5 data/log	4x 10GbE 4x 1GigE
12,288 GB‡	8SKL12288 SSDG	Scaleout to 4+1 node	8x 8176M	12,288 GB (96x 128 GB)	2x 400GB SSD 18x 7.68TB SSD	2x 930-16i	122.8 TB RAID-5 data/log	4x 10GbE 4x 1GigE

* For S/4HANA and Suite on HANA only (not for Datamart, BWoH and BW/4)

** Up to 4 nodes for S/4HANA (scale-out up to 94 nodes for Datamart, BWoH and BW/4H only)

‡ For S/4HANA only

† if 9x 7.68TB drives are used, then use 1x 930-16i RAID adapter

Each of these HANA configurations include the following components

- Processors:
 - Each configuration listed in the table uses either the Platinum 8176 or 8176M processors, depending on the amount of memory installed. The Platinum 8180 and 8180M can also be used if greater performance is desired.
 - An M-suffix processor is required for 8-socket configurations with 12TB of memory, for 4-socket configurations with 6TB of memory, or for 2-socket configurations with 3TB of memory.
- Networking:
 - Two or more Mellanox ConnectX-4 Lx 2x 25GbE Adapters with 10 GbE transceivers (SFP+ SR Transceiver, 46C3447)
 - One or more ThinkSystem Intel I350-T4 ML2 1Gb 4-Port RJ45 Ethernet Adapters
- Storage
 - ThinkSystem 2.5" 400GB Mainstream SAS 12Gb Hot Swap SSDs
 - ThinkSystem 2.5" 3.84TB Capacity SAS 12Gb Hot Swap SSDs
- RAID Adapter:
 - One or two ThinkSystem RAID 930-16i 4GB Flash PCIe 12Gb Adapter
 - Optional RAID 930-8e 4GB Flash PCIe 12Gb Adapters for external storage connectivity
- Lenovo solution for SAP HANA media

Note: The operating system software is *not* included with the SAP HANA models. Operating system selection must be a separate line item included in order: SLES for SAP with standard or priority support. The SAP HANA Software is included, but the license is sold separately by SAP or an SAP business partner. VMware Enterprise Plus license sold separately. IBM Spectrum Scale (GPFS) is available from Lenovo separately.

For more information about the standard features of the server, see the [Standard specifications](#) section.

Processor options

The SR950 supports the Gold and Platinum level processors in the Intel Xeon Processor Scalable Family, including the "top bin" highest performing 205 W processors available from Intel.

The server supports up to four or eight processors, depending on the configuration selected, however processors are all installed within the 4U rack enclosure:

- For configurations that support up to eight processors, the server supports 2, 4 or 8 processors. (There is no support for 6-processor configurations.)
- For configurations of up to four processors (lower cost configuration, no upgrade path to eight processors), the server supports 2 or 4 processors

As described in the [Components and connectors](#) section, processors and memory are located on compute system boards - two processors per board. Two system boards are installed in a compute tray, and there are two compute trays in the server.

For configurations with only one compute tray, you can upgrade to add a second compute tray. You can also add additional system boards as needed. The ordering information for these upgrades is listed in the following table.

Table 14. Compute tray and system board upgrades

Part number	Feature code	Description
7XG7A03955	AUN0	ThinkSystem SR950 2-CPU, 24 DIMM Compute System Board
7XG7A03956	Various	ThinkSystem SR950 Upper Compute Tray Kit

The Compute System Board option, 7XG7A03955, includes the following components:

- One compute system board, without processors or memory

The Upper Compute Tray Kit, 7XG7A03956, includes the following components:

- 1x compute tray with 12 drive bays and 1 slot for storage adapter
- 1x compute system board
- 3x 4-bay drive bay fillers

Note: the Upper Compute Tray Kit does not include drive backplanes

The table below lists the supported processors. The table indicates which processors support 8-socket configurations and whether the processors support memory capacities greater than 768 GB per processor.

All processors listed support:

- Hyper-Threading Technology
- Turbo Boost Technology 2.0

The table also lists the number of UltraPath Interconnect (UPI) ports each processor has. UPI ports are used to connect processors together for high-speed communications.

- When a processor has 3 UPI ports, it can be used in a 4-socket mesh configuration where all processors are directly connected to every other processor. 5100 Series processors do not support mesh topology, since they only have 2 UPI ports.
- When a processor has only 2 UPI ports, it can only be used in a 4-socket ring configuration where all processors are connected to the 2 adjacent processors and the fourth processor is only connected indirectly via another processor.

The mesh and ring topologies are shown in the following figure.

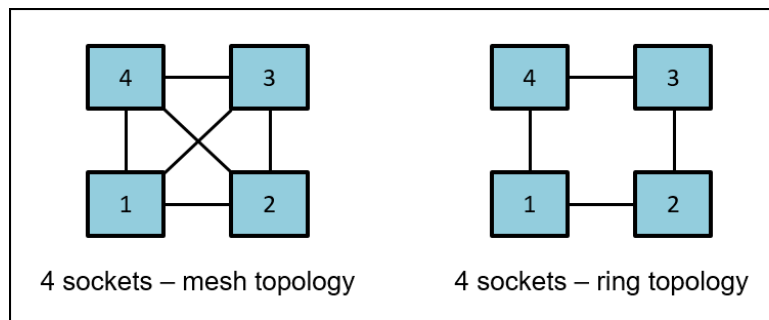

Figure 10. Mesh and ring processor topologies

Table 15. Processor options

Part number	Feature code	Intel Xeon processor	Suitable for 8-socket	Memory speed	Supports >768 GB per CPU	L3 cache	UPI links	AVX-512 units
4XG7A08857	AX8M	Gold 5115 10C 85W 2.4GHz	No	2400 MHz	No	13.75 MB	2	1
4XG7A08845	AX7D	Gold 5118 12C 105W 2.3GHz	No	2400 MHz	No	16.5 MB	2	1
4XG7A08832	AX7C	Gold 5120 14C 105W 2.2GHz	No	2400 MHz	No	19.25 MB	2	1
4XG7A08831	AX7E	Gold 5120T 14C 105W 2.2GHz	No	2400 MHz	No	19.25 MB	2	1
4XG7A08849	AX70	Gold 5122 4C 105W 3.6GHz	No	2666 MHz*	No	16.5 MB**	2	2*
4XG7A08835	AWEX	Gold 6126 12C 125W 2.6GHz	No	2666 MHz	No	19.25 MB**	3	2
4XG7A08853	AX73	Gold 6126T 12C 125W 2.6GHz	No	2666 MHz	No	19.25 MB**	3	2
4XG7A08846	AX6Z	Gold 6128 6C 115W 3.4GHz	No	2666 MHz	No	19.25 MB**	3	2
4XG7A08833	AX6D	Gold 6130 16C 125W 2.1GHz	No	2666 MHz	No	22 MB	3	2
4XG7A08851	AX72	Gold 6130T 16C 125W 2.1GHz	No	2666 MHz	No	22 MB	3	2
4XG7A08838	AX6U	Gold 6132 14C 140W 2.6GHz	No	2666 MHz	No	19.25 MB	3	2
4XG7A08847	AX6Y	Gold 6134 8C 130W 3.2GHz	No	2666 MHz	No	24.75 MB**	3	2
4XG7A08863	AX7A	Gold 6134M 8C 130W 3.2GHz	No	2666 MHz	Yes	24.75 MB**	3	2
4XG7A08848	AX6W	Gold 6136 12C 150W 3.0GHz	No	2666 MHz	No	24.75 MB**	3	2
4XG7A08834	AX6Q	Gold 6138 20C 125W 2.0GHz	No	2666 MHz	No	27.5 MB	3	2
4XG7A08852	AX71	Gold 6138T 20C 125W 2.0GHz	No	2666 MHz	No	27.5 MB	3	2
4XG7A08836	AX6R	Gold 6140 18C 140W 2.3GHz	No	2666 MHz	No	24.75 MB	3	2
4XG7A08858	AX79	Gold 6140M 18C 140W 2.3GHz	No	2666 MHz	Yes	24.75 MB	3	2
4XG7A08839	AX6E	Gold 6142 16C 150W 2.6GHz	No	2666 MHz	No	22 MB	3	2
4XG7A08859	AX78	Gold 6142M 16C 150W 2.6GHz	No	2666 MHz	Yes	22 MB	3	2
4XG7A08840	AWEW	Gold 6148 20C 150W 2.4GHz	No	2666 MHz	No	27.5 MB	3	2
7XG7A05005	AX6T	Gold 6150 18C 165W 2.7GHz	No	2666 MHz	No	24.75 MB	3	2
4XG7A08837	AX6P	Gold 6152 22C 140W 2.1GHz	No	2666 MHz	No	30.25 MB	3	2
7XG7A03957	AX6S	Gold 6154 18C 200W 3.0GHz	No	2666 MHz	No	24.75 MB	3	2
4XG7A08854	AX6L	Platinum 8153 16C 125W 2.0GHz	Yes	2666 MHz	No	22 MB	3	2
4XG7A08850	AWEV	Platinum 8156 4C 105W 3.6GHz	Yes	2666 MHz	No	16.5 MB**	3	2
4XG7A08855	AX7B	Platinum 8158 12C 150W 3.0GHz	Yes	2666 MHz	No	24.75 MB**	3	2
4XG7A08841	AWGJ	Platinum 8160 24C 150W 2.1GHz	Yes	2666 MHz	No	33 MB	3	2
4XG7A08860	AX77	Platinum 8160M 24C 150W 2.1GHz	Yes	2666 MHz	Yes	33 MB	3	2
4XG7A08856	AX6N	Platinum 8160T 24C 150W 2.1GHz	Yes	2666 MHz	No	33 MB	3	2
4XG7A08842	AX6K	Platinum 8164 26C 150W 2.0GHz	Yes	2666 MHz	No	35.75 MB	3	2
7XG7A03958	AX6M	Platinum 8168 24C 205W 2.7GHz	Yes	2666 MHz	No	33 MB	3	2
4XG7A08843	AX6J	Platinum 8170 26C 165W 2.1GHz	Yes	2666 MHz	No	35.75 MB	3	2
4XG7A08862	AX76	Platinum 8170M 26C 165W 2.1GHz	Yes	2666 MHz	Yes	35.75 MB	3	2
4XG7A08844	AX6H	Platinum 8176 28C 165W 2.1GHz	Yes	2666 MHz	No	38.5 MB	3	2

Part number	Feature code	Intel Xeon processor	Suitable for 8-socket	Memory speed	Supports >768 GB per CPU	L3 cache	UPI links	AVX-512 units
4XG7A08861	AX75	Platinum 8176M 28C 165W 2.1GHz	Yes	2666 MHz	Yes	38.5 MB	3	2
7XG7A03959	AX6G	Platinum 8180 28C 205W 2.5GHz	Yes	2666 MHz	No	38.5 MB	3	2
7XG7A03960	AX74	Platinum 8180M 28C 205W 2.5GHz	Yes	2666 MHz	Yes	38.5 MB	3	2

* All Gold 5000-level processors, except the 5122, support 2400 MHz memory speeds and have one AVX-512 512-bit FMA units. The 5122 processor supports 2666 MHz and has two FMA units

** L3 cache is 1.375 MB per core except with the processors indicated with **

Memory options

The SR950 uses Lenovo TruDDR4 memory operating at up to 2666 MHz. The server supports 12 DIMMs per processor, which corresponds to 48 DIMMs with four processors installed and 96 DIMMs when eight processors are installed. Each processor has six memory channels with two DIMMs per channel. With 128 GB 3DS RDIMMs installed, an 8-socket server supports a total of 12 TB of system memory.

As described in the [Components and connectors](#) section, the memory is installed on compute system boards and there are two system boards per compute tray and one or two compute trays per server, depending on the configuration.

All DIMMs operate at a speed of 2666 MHz, both at 1 DIMM per channel and 2 DIMMs per channel. However, if the processor selected has a lower memory bus speed (eg 2400 MHz), then all DIMMs will operate at that lower speed.

The following table lists the memory options that are available for SR950.

Lenovo TruDDR4 memory uses the highest quality components that are sourced from Tier 1 DRAM suppliers and only memory that meets the strict requirements of Lenovo is selected. It is compatibility tested and tuned to maximize performance and reliability. From a service and support standpoint, Lenovo TruDDR4 memory automatically assumes the system warranty, and Lenovo provides service and support worldwide.

Table 16. Memory options

Part number	Feature code	Description	Maximum supported
RDIMMs			
7X77A01302	AUNB	ThinkSystem 16GB TruDDR4 2666 MHz (1Rx4 1.2V) RDIMM	96 (12 per processor)
7X77A01303	AUNC	ThinkSystem 16GB TruDDR4 2666 MHz (2Rx8 1.2V) RDIMM	96 (12 per processor)
7X77A01304	AUND	ThinkSystem 32GB TruDDR4 2666 MHz (2Rx4 1.2V) RDIMM	96 (12 per processor)
LRDIMMs			
7X77A01305	AUNE	ThinkSystem 64GB TruDDR4 2666 MHz (4Rx4 1.2V) LRDIMM	96 (12 per processor)
3DS RDIMMs			
7X77A01307	AUNF	ThinkSystem 128GB TruDDR4 2666 MHz (8Rx4 1.2V) 3DS RDIMM	96 (12 per processor)

The following rules apply when selecting the memory configuration:

- The server supports RDIMMs, LRDIMMs and 3DS RDIMMs. UDIMMs are not supported.
- Mixing RDIMMs and LRDIMMs is not supported.
- Mixing 3DS RDIMMs with either RDIMMs or LRDIMMs is not supported.

- Mixing x4 and x8 DIMMs is supported.

For best performance, consider the following:

- Populate memory DIMMs in quantities of 6 or 12 per processor, so that all memory channels are used.
- When mixing 16 GB and 32 GB DIMMs in the same configuration, use 16GB 2Rx8 DIMMs instead of 16 GB 1Rx4 DIMMs for better performance.
- Populate memory channels so they all have the same total memory capacity
- Ensure all memory controllers on a processor socket have the same DIMM configuration.
- All processor sockets on the same physical server should have the same DIMM configuration.

The following memory protection technologies are supported:

- ECC
- Chipkill (for x4-based memory DIMMs; look for "x4" in the DIMM description)
- Adaptive double-device data correction (ADDDC)
- Memory mirroring
- Memory rank sparing

If memory channel mirroring is used, then DIMMs must be installed in pairs or sets of three (minimum of one pair or set of three per processor), and all DIMMs in the pair or set of three must be identical in type and size. 50% of the installed capacity is available to the operating system.

If memory rank sparing is used, then a minimum of two single-rank or dual-rank DIMMs must be installed per populated channel (the DIMMs do not need to be identical). In rank sparing mode, one rank of a DIMM in each populated channel is reserved as spare memory. The largest rank in the channel will be automatically selected as the spare rank. The amount of memory available to the operating system depends on the number, capacity and rank counts of the DIMMs installed.

Internal storage

The SR950 offers up to 24x 2.5-inch drive bays, depending on the server configuration selected (as described in [Server configurations](#)). The server also supports either one or two M.2 drives, installed in an M.2 adapter.

In this section:

- [Backplanes and drive bays](#)
- [Adapters and cabling](#)
- [Field upgrades](#)
- [M.2 drives](#)

Backplanes and drive bays

Drives are all located at the front of the server, 12 drives at the front of the upper tray and 12 at the front of the lower tray. Drives connect to 4-drive backplanes in a 2-by-2 configuration, as shown in the following figure. All drive bays are 2.5-inch form factor.

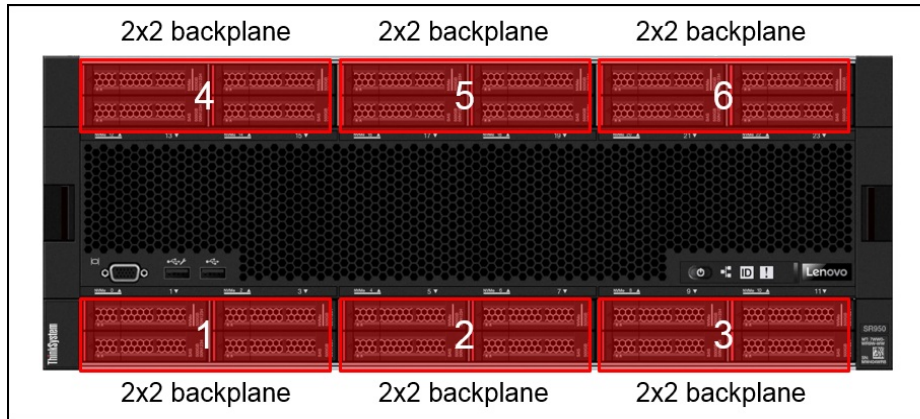

Figure 11. Location of backplanes

There are two different backplanes available for the SR950:

- SAS/SATA backplane: Supports 4 SAS or SATA drives
- AnyBay backplane:
 - Top two drives support SAS, SATA, or NVMe interface drives (Lenovo AnyBay)
 - Bottom two drive bays support SAS or SATA drives only

Regular 2.5-inch SAS/SATA drive bays support only SAS or SATA drives; however, the Lenovo AnyBay drive bay design allows a choice of SATA, SAS, or U.2 (NVMe) PCIe drives. This design enables the flexibility to configure some of the bays with high-performance PCIe SSDs while still using the other bays for high-capacity HDDs, which is an ideal solution for storage-tiering.

Table 17. Drive backplanes

Part number	Feature code	Description	Maximum supported
7XB7A03966	AUN6	ThinkSystem 2.5" SAS/SATA 2x2 Bay Backplane Kit	6
7XB7A03965	AUN5	ThinkSystem 2.5" SAS/SATA/NVMe 2x2 Bay Backplane Kit	6

If the server is configured with all AnyBay backplanes, then the server supports up to 12 NVMe drives, depending on the server configuration. The quantity and location of the AnyBay drive bays depends on the configuration, as listed in the following table.

See the [Server configurations](#) section for details about the five server configurations

Table 18. Drive bays and NVMe support for each SR950 configuration

Configuration	Maximum storage	Location of NVMe drive bays
4S Performance	12 drives (6 NVMe)	Top row of drive bays
4S Performance/ Storage Rich	24 drives (12 NVMe)	Top row of drive bays in each tray
4S Upgradable	12 drives (6 NVMe)	Top row of drive bays
4S Upgradable/ Storage Rich	24 drives (4 NVMe)	Two drive bays in each tray, top-right drive bays
8S Storage Rich	24 drives (12 NVMe)	Top row of drive bays in each tray

Backplane connections are as follows:

- The 4-drive SAS/SATA backplane has one SAS/SATA connector and connects to a supported RAID controller or SAS HBA installed in the dedicated storage adapter slot.
- The 4-drive AnyBay backplane has one SAS/SATA connector and connects to a supported RAID controller or SAS HBA plus one NVMe connector to connect to NVMe ports on one of the system boards in a compute tray or directly on the storage tray.

The SAS/SATA backplane is shown in the following figure.

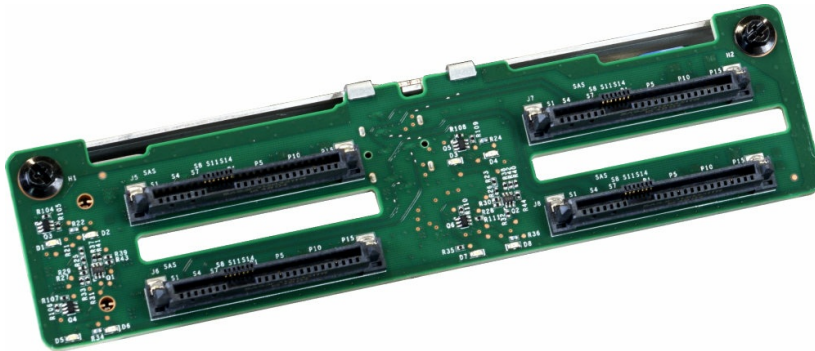

Figure 12. SAS/SATA backplane

Adapters and cabling

Each compute tray or storage tray includes one dedicated PCIe slot for a RAID adapter or SAS HBA.

Tip: The adapters are described in detail in the [Controllers for internal storage](#) section.

SAS/SATA backplanes are connected to the RAID adapter or HBA installed in the dedicated slot in that tray. AnyBay backplanes (NVMe support on 2 of the 4 drive bays) are connected to the RAID adapter or HBA or to an NVMe port adjacent to processor on a system board.

The following table lists which processor each SAS/SATA storage adapter and which NVMe port each backplane is connected to.

Processor numbering is shown in [Figure 7](#).

Table 19. Processor connectivity for storage adapters and NVMe ports

Configuration	Slot location	4S Performance	4S Performance/ Storage Rich	4S Upgradeable	4S Upgradeable/ Storage Rich	8S Storage Rich
Processors installed		1,2 or 1,2,3,4	1,2,3,4	1,2 or 1,2,3,4	1,2,5,6	1,2,3,4,5,6,7,8
Storage adapter slot	Upper tray	NC	1	NC	5	5
Storage adapter slot	Lower tray	1	1	1	1	1
NVMe on backplane 4	Upper tray	NC	3	NC	NC	7
NVMe on backplane 5		NC	4	NC	NC	8
NVMe on backplane 6		NC	2	NC	6	6
NVMe on backplane 1	Lower tray	3*	3	3*	NC	3
NVMe on backplane 2		4*	4	4*	NC	4
NVMe on backplane 3		2	2	2	2	2

* In 2-processor configurations, processors 3 and 4 are not installed; this means drive backplanes 1 and 2 cannot be AnyBay backplanes.

M.2 drives

The server supports one or two M.2 form-factor SATA drives for use as an operating system boot solution. With two M.2 drives configured, the drives are configured by default as a RAID-1 mirrored pair for redundancy.

The M.2 drives install into an M.2 adapter which in turn is installed in a dedicated slot on the system board. See the internal view of the server in the [Components and connectors](#) section for the location of the M.2 slot.

There are two M.2 adapters supported:

- Single M.2 Boot Adapter, which supports one M.2 drive; available as ThinkSystem M.2 Enablement Kit, 7Y37A01092
- Dual M.2 Boot Adapter, which supports one or two M.2 drives; available as ThinkSystem M.2 with Mirroring Enablement Kit, 7Y37A01093

A Dual M.2 Boot Adapter with one 128GB M.2 drive partially inserted is shown in the following figure. The second M.2 drive is installed on the other side of the adapter.



Figure 13. Dual M.2 Boot Adapter and a 128 GB M.2 drive

Features of the Dual M.2 Boot Adapter:

- PCIe 2.0 x2 host interface (connects to the PCH)
- Based on the Marvell 88SE9230 6 Gbps SATA controller
- Supports two 6 Gbps SATA M.2 drives (it is not supported to have only one drive installed)
- Supports 3 different physical sizes of M.2 drives: 42mm (2242), 60mm (2260) and 80mm (2280)*
- RAID functionality provided by the M.2 adapter
- RAID 1 by default; also supports RAID 0 and JBOD
- UEFI-based settings to enable/disable RAID mode and to review inventory
- Adapter and drive firmware update using Lenovo firmware tools
- Management via I2C interface

* 2242, 2260 and 2280 are the industry terms for the M.2 drive dimensions. For example, 2280 corresponds to a drive that is 22mm wide and 80mm long.

Features of the Single M.2 Boot Adapter:

- 6 Gbps SATA host interface (connects to the PCH)
- Supports one 6 Gbps SATA M.2 drive
- Supports 3 different physical sizes of M.2 drives: 42mm (2242), 60mm (2260) and 80mm (2280)
- Drive firmware update using Lenovo firmware tools
- Management via I2C interface
- VPD reporting of adapter inventory

The Single M.2 Boot Adapter is shown in the following photo, with the 32GB M.2 drive installed.



Figure 14. Single M.2 Boot Adapter and a 32 GB M.2 drive

The M.2 components are listed in the following table.

Table 20. M.2 components

Part number	Feature code	Description	Maximum Supported
7Y37A01092	AUMU	ThinkSystem M.2 Enablement Kit (contains the Single M.2 Boot Adapter; supports 1 drive)	1
7Y37A01093	AUMV	ThinkSystem M.2 with Mirroring Enablement Kit (contains the Dual M.2 Boot Adapter, supports 1 or 2 drives)	1
7N47A00129	AUUL	ThinkSystem M.2 CV1 32GB SATA 6Gbps Non-Hot-Swap SSD	1 / 2*
7N47A00130	AUUV	ThinkSystem M.2 CV3 128GB SATA 6Gbps Non-Hot-Swap SSD	1 / 2*

* 7Y37A01092 supports a maximum of one M.2 drive; 7Y37A01093 supports a maximum of two M.2 drives; drives must be identical.

The following table lists the specifications of the M.2 drives.

Table 21. M.2 drive specifications

Specification	32 GB M.2	128 GB M.2
Part number	7N47A00129	7N47A00130
Recommended use	Boot drive*	Boot drive*
Interface	6Gb SATA	6Gb SATA
Flash Type	MLC NAND	TLC NAND
4KB Random Read/Write Performance	25,000 IOPS	72,000 IOPS
4KB Random Write Performance	10,500 IOPS	32,000 IOPS
Sequential Read Performance	260 MB/s	530 MB/s
Sequential Write Performance	40 MB/s	470 MB/s
Endurance (total bytes written / drive writes per day)	37.92TB / 0.66 DWPD	63.9 TB / 0.28 DWPD
Vendor model	LiteOn CV1	LiteOn CV3
Dimensions	42 x 22 mm	80 x 22 mm

* These drive options do not have power-loss capacitors, which means they do not have protection against a potential loss of data when a write operation is underway just as a power outage occurs. As a result, these drives are not recommended for general purpose storage functions.

Controllers for internal storage

The SR950 supports internal SAS and SATA drives with the addition of a RAID adapter or HBA. The adapter is installed in a dedicated slot in each compute tray. For NVMe support, the server uses NVMe ports that are on the compute system boards or on the storage tray if one is configured.

The following table lists the supported adapters.

Tip: Unlike System x RAID adapters, no upgrades are available for these RAID adapters. All supported functions are included with the base part numbers.

Table 22. Controllers for internal storage

Part number	Feature code	Description	Number of ports	Maximum supported
SAS/SATA HBA				
7Y37A01088	AUNL	ThinkSystem 430-8i SAS/SATA 12Gb HBA	8	2
7Y37A01089	AUNM	ThinkSystem 430-16i SAS/SATA 12Gb HBA	12**	2
RAID adapters				
7Y37A01082	AUNG	ThinkSystem RAID 530-8i PCIe 12Gb Adapter	8	2
7Y37A01083*	AUNH*	ThinkSystem RAID 730-8i 1GB Cache PCIe 12Gb Adapter	8	2
7Y37A01084	AUNJ	ThinkSystem RAID 930-8i 2GB Flash PCIe 12Gb Adapter	8	2
7Y37A01085	AUNK	ThinkSystem RAID 930-16i 4GB Flash PCIe 12Gb Adapter	12**	2

* The RAID 730-8i is available in China only

** The 430-16i HBA and RAID 930-16i adapter support 12 drives when used in the SR950

The following table compares the functions of the storage adapters.

Table 23. Comparison of internal storage controllers

Feature	430-8i	430-16i	RAID 530-8i	RAID 730-8i†	RAID 930-8i	RAID 930-16i
Adapter type	HBA	HBA	RAID controller	RAID controller	RAID controller	RAID controller
Part number	7Y37A01088	7Y37A01089	7Y37A01082	7Y37A01083	7Y37A01084	7Y37A01085
Form factor	PCIe low profile	PCIe low profile	PCIe HHHL	PCIe low profile	PCIe HHHL	PCIe HHHL
Controller chip	LSI SAS3408	LSI SAS3416	LSI SAS3408	LSI SAS3108	LSI SAS3508	LSI SAS3516
Broadcom equivalent	HBA 9400-8i	HBA 9400-16i	MegaRAID 9440-8i	MegaRAID 9361-8i	MegaRAID 9460-8i	MegaRAID 9460-16i
Host interface	PCIe 3.0x8	PCIe 3.0x8	PCIe 3.0x8	PCIe 3.0x8	PCIe 3.0x8	PCIe 3.0x8
Port interface	12 Gb SAS	12 Gb SAS	12 Gb SAS	12 Gb SAS	12 Gb SAS	12 Gb SAS
Number of ports	8	16	8	8	8	16
Port connectors	2x Mini-SAS HD x4 (SFF-8643)	4x Mini-SAS HD x4 (SFF-8643)	2x Mini-SAS HD x4 (SFF-8643)	2x Mini-SAS HD x4 (SFF-8643)	2x Mini-SAS HD x4 (SFF-8643)	4x Mini-SAS HD x4 (SFF-8643)
Drive interface	SAS, SATA	SAS, SATA	SAS, SATA	SAS, SATA	SAS, SATA	SAS, SATA
Drive type	HDD, SSD, SED*	HDD, SSD, SED*	HDD, SED, SSD	HDD, SED, SSD	HDD, SED, SSD	HDD, SED, SSD
Hot-swap drives	Yes	Yes	Yes	Yes	Yes	Yes
Max devices	8	12**	8	8	8	12**
RAID levels	No RAID	No RAID	0, 1, 10, 5, 50	0, 1, 10, 5, 50	0, 1, 10, 5, 50, 6, 60	0, 1, 10, 5, 50, 6, 60
JBOD mode	Yes	Yes	Yes	Yes	Yes	Yes
Cache	No	No	None	1GB (Standard)	2GB (Standard)	4GB (Standard)
CacheVault cache protection	No	No	No	No	Yes (Flash)	Yes (Flash)
Performance Accelerator (FastPath)	No	No	Yes	No	Yes	Yes
SSD Caching (CacheCade Pro 2.0)	No	No	No	No	No	No
SED support*	Yes	Yes	Yes	Yes	Yes	Yes

† The RAID 730-8i adapter is for China only

* SED (self-encrypting drive) support of the SAS HBAs is by using software on the server (SED commands are passed through the HBA to the drives). SED support by RAID controllers is provided using the built-in MegaRAID SafeStore functionality of the adapter.

** With the SR950, the 430-16i HBA and RAID 930-16i support up to 12 drives.

Internal drive options

The following tables list the hard disk drive and solid-state drive options for the internal disk storage of the server.

- Table 23: [2.5-inch hot-swap 12 Gb SAS HDDs](#)
- Table 24: [2.5-inch hot-swap 12 Gb SAS SSDs](#)
- Table 25: [2.5-inch hot-swap 6 Gb SAS/SATA SSDs](#)
- Table 26: [2.5-inch U.2 NVMe SSDs](#)

Tip: The server also supports M.2 drives as described in the [M.2 drives](#) subsection.

Table 24. 2.5-inch hot-swap 12 Gb SAS HDDs

Part number	Feature	Description	Maximum supported
2.5-inch hot-swap HDDs - 12 Gb SAS 10K			
7XB7A00024	AULY	ThinkSystem 2.5" 300GB 10K SAS 12Gb Hot Swap 512n HDD	24
7XB7A00025	AULZ	ThinkSystem 2.5" 600GB 10K SAS 12Gb Hot Swap 512n HDD	24
7XB7A00026	AUM0	ThinkSystem 2.5" 900GB 10K SAS 12Gb Hot Swap 512n HDD	24
7XB7A00027	AUM1	ThinkSystem 2.5" 1.2TB 10K SAS 12Gb Hot Swap 512n HDD	24
7XB7A00028	AUM2	ThinkSystem 2.5" 1.8TB 10K SAS 12Gb Hot Swap 512e HDD	24
2.5-inch hot-swap HDDs - 12 Gb SAS 15K			
7XB7A00021	AULV	ThinkSystem 2.5" 300GB 15K SAS 12Gb Hot Swap 512n HDD	24
7XB7A00022	AULW	ThinkSystem 2.5" 600GB 15K SAS 12Gb Hot Swap 512n HDD	24
7XB7A00023	AULX	ThinkSystem 2.5" 900GB 15K SAS 12Gb Hot Swap 512e HDD	24
2.5-inch hot-swap HDDs - 12 Gb NL SAS			
7XB7A00034	AUM6	ThinkSystem 2.5" 1TB 7.2K SAS 12Gb Hot Swap 512n HDD	24
7XB7A00035	AUM7	ThinkSystem 2.5" 2TB 7.2K SAS 12Gb Hot Swap 512n HDD	24
2.5-inch hot-swap SED HDDs - 12 Gb SAS 10K			
7XB7A00030	AUM4	ThinkSystem 2.5" 300GB 10K SAS 12Gb Hot Swap 512n HDD SED	24
7XB7A00031	AUM5	ThinkSystem 2.5" 600GB 10K SAS 12Gb Hot Swap 512n HDD SED	24

Table 25. 2.5-inch hot-swap 12 Gb SAS SSDs

Part number	Feature	Description	Maximum supported
2.5-inch hot-swap SSDs - 12 Gb SAS - Enterprise Capacity			
7N47A00121	AUMK	ThinkSystem 2.5" PM1633a 3.84TB Capacity SAS 12Gb Hot Swap SSD	24
7N47A00122	AUML	ThinkSystem 2.5" PM1633a 7.68TB Capacity SAS 12Gb Hot Swap SSD	24
2.5-inch hot-swap SSDs - 12 Gb SAS - Enterprise Performance (10+ DWPD)			
7N47A00124	AUMG	ThinkSystem 2.5" HUSMM32 400GB Performance SAS 12Gb Hot Swap SSD	24
7N47A00125	AUMH	ThinkSystem 2.5" HUSMM32 800GB Performance SAS 12Gb Hot Swap SSD	24
2.5-inch hot-swap SSDs - 12 Gb SAS - Enterprise Mainstream (3-5 DWPD)			
7N47A00117	AUMC	ThinkSystem 2.5" PM1635a 400GB Mainstream SAS 12Gb Hot Swap SSD	24
7N47A00118	AUMD	ThinkSystem 2.5" PM1635a 800GB Mainstream SAS 12Gb Hot Swap SSD	24

Table 26. 2.5-inch hot-swap 6 Gb SAS/SATA SSDs

Part number	Feature	Description	Maximum supported
2.5-inch hot-swap SSDs - 6 Gb SATA - Enterprise Entry (<3 DWPD)			
7N47A00099	AUM8	ThinkSystem 2.5" Intel S3520 240GB Entry SATA 6Gb Hot Swap SSD	24
7N47A00100	AUUZ	ThinkSystem 2.5" Intel S3520 480GB Entry SATA 6Gb Hot Swap SSD	24
7N47A00111	AUUQ	ThinkSystem 2.5" PM863a 240GB Entry SATA 6Gb Hot Swap SSD	24
7N47A00112	AUM9	ThinkSystem 2.5" PM863a 480GB Entry SATA 6Gb Hot Swap SSD	24

Table 27. 2.5-inch U.2 NVMe SSDs

Part number	Feature	Description	Maximum supported
2.5-inch SSDs - NVMe - Enterprise Performance (10+ DWPD)			
7XB7A05923	AWG6	ThinkSystem U.2 PX04PMB 800GB Performance NVMe PCIe 3.0 x4 Hot Swap SSD	12
7XB7A05922	AWG7	ThinkSystem U.2 PX04PMB 1.6TB Performance NVMe PCIe 3.0 x4 Hot Swap SSD	12
2.5-inch SSDs - NVMe - Enterprise Mainstream (3-5 DWPD)			
7N47A00095	AUJY	ThinkSystem U.2 PX04PMB 960GB Mainstream NVMe PCIe 3.0 x4 Hot Swap SSD	12
7N47A00096	AUMF	ThinkSystem U.2 PX04PMB 1.92TB Mainstream NVMe PCIe 3.0 x4 Hot Swap SSD	12
2.5-inch SSDs - NVMe - Enterprise Entry (<3 DWPD)			
7N47A00984	AUV0	ThinkSystem U.2 PM963 1.92TB Entry NVMe PCIe 3.0 x4 Hot Swap SSD	12
7N47A00985	AUUU	ThinkSystem U.2 PM963 3.84TB Entry NVMe PCIe 3.0 x4 Hot Swap SSD	12

Note: NVMe PCIe SSDs support informed hot removal and hot insertion, provided the operating system supports PCIe SSD hot-swap.

Internal backup units

The server does not support any internal backup units.

Optical drives

The server does not support an internal optical drive.

An external USB optical drive is available, listed in the following table.

Table 28. External optical drive

Part number	Feature code	Description
7XA7A05926	AVV8	ThinkSystem External USB DVD RW Optical Disk Drive

I/O expansion options

The server supports the following PCIe slots, depending on the server configuration selected:

- Slots 1-17 are PCIe 3.0 slots accessible from the rear of the server
- One internal dedicated M.2 slot for an M.2 adapter located internally on the I/O tray
- Two internal dedicated PCIe 3.0 x8 slots for storage adapters, located internally in each compute tray or storage tray

The following figure shows the locations of the slots at the rear of the server.

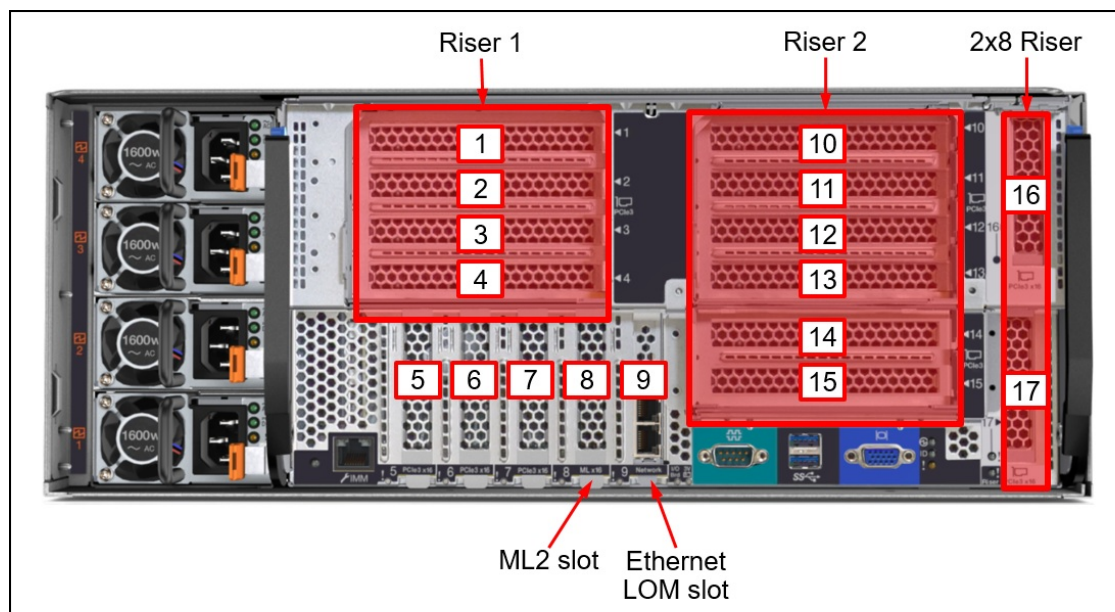

Figure 15. PCIe 3.0 slots at the rear of the server

The 17 PCIe 3.0 rear-accessible slots are as follows:

- Slots 1-4 are via Riser Slot 1, one riser card of:
 - Riser with 4x PCIe 3.0 x16 slots, all full-height half-length, all 75W
 - Riser with 2x PCIe 3.0 x16 slots, all full-height half-length, both 75W
 - Riser with 4x PCIe 3.0 x8 slots, full-height half-length, all 75W
- Slot 5: PCIe 3.0 x16, low profile, 75W
- Slot 6: PCIe 3.0 x16, low profile, 75W
- Slot 7: PCIe 3.0 x8, low profile, 75W
- Slot 8: PCIe 3.0 x16 ML2, low profile (supports NC-SI)
- Slot 9: PCIe 3.0 x8 LOM adapter slot, low profile (supports NC-SI)
- Slots 10-15 are via Riser Slot 2, one riser card of:
 - Riser 5x16+ML2
 - Five PCIe 3.0 x16 slots, all full-height half-length, all 75W
 - One PCIe 3.0 x16 ML2 slot, full-height half-length, 30W (no NC-SI support)
 - Riser 2x16: Two PCIe 3.0 x16 slots, all full-height half-length, both 75W
 - Riser 4x8: Four PCIe 3.0 x8 slots, full-height half-length, all 75W
- Slot 16-17 on a riser:
 - PCIe 3.0 x8 low profile, 75W
 - PCIe 3.0 x8 low profile, 75W

Additional internal PCIe slots:

- One or two PCIe 3.0 x8 slots for storage adapters, one in each compute tray
- M.2 adapter slot

NC-SI (Network Controller Sideband Interface or NCSI) support means the primary port on the adapter installed in that slot can be configured as shared between XCC out-of-band management traffic and production Ethernet traffic.

For riser slots 1 and 2, the server supports the following three riser cards. These are shown in the figure below.

- Riser 5x16+ML2:
 - Five PCIe 3.0 x16 slots, all full-height half-length, all 75W
 - One PCIe 3.0 x16 ML2 slot, full-height half-length, 30W (no NC-SI support)**Note:** When the 5x16+ML2 riser is installed in riser slot 1, the bottom two slots (including the ML2) are not accessible and cannot be used.
- Riser 2x16: Two PCIe 3.0 x16 slots, all full-height half-length, both 75W
- Riser 4x8: Four PCIe 3.0 x8 slots, full-height half-length, all 75W

Note: The ML2 slot on the riser card does not support NC-SI.

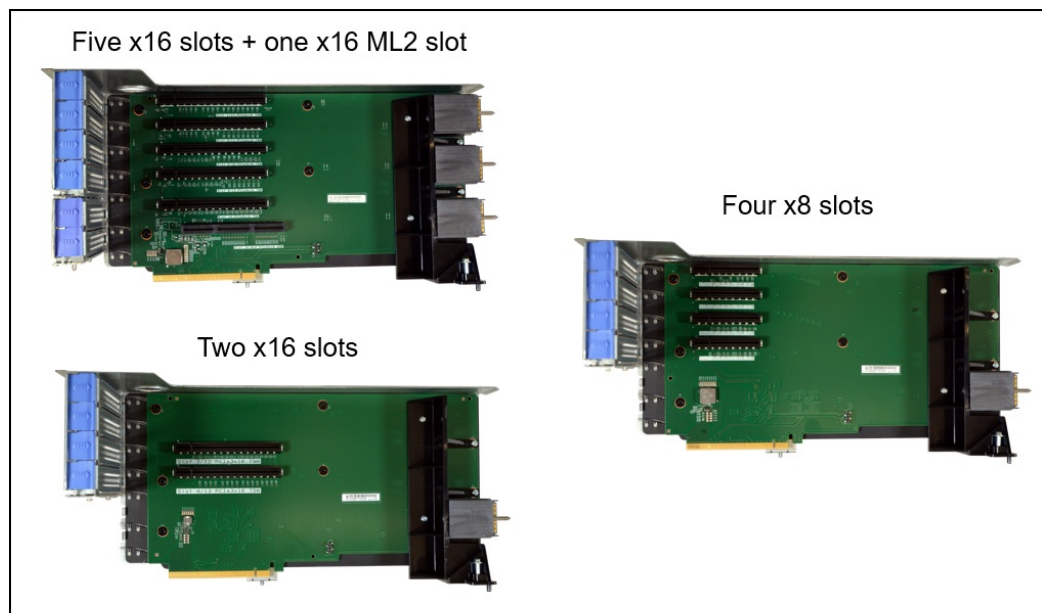

Figure 16. Riser cards for riser slots 1 and 2

Slot numbering is as follows:

- When installed in riser slot 1:
 - Riser 5x16+ML2 becomes slots 1-4 (bottom two slots inaccessible)
 - Riser 2x16 becomes slots 3-4
 - Riser 4x8 becomes slots 1-4
- When installed in riser slot 2:
 - Riser 5x16+ML2 becomes slots 10-15
 - Riser 2x16 becomes slots 12-13
 - Riser 4x8 becomes slots 10-13

Note: When the 5x16+ML2 riser card is used in Riser slot 1, only the top 4 slots (all x16) are accessible. The lower x16 and x16 ML2 slots cannot physically be accessed or used.

Slots 16 and 17 are mounted on a single 2x8 riser card and are as follows:

- Slot 16: PCIe 3.0 x8, full-height half-length, 75W
- Slot 17: PCIe 3.0 x8, full-height half-length, 75W

The 2x8 riser card is shown below.

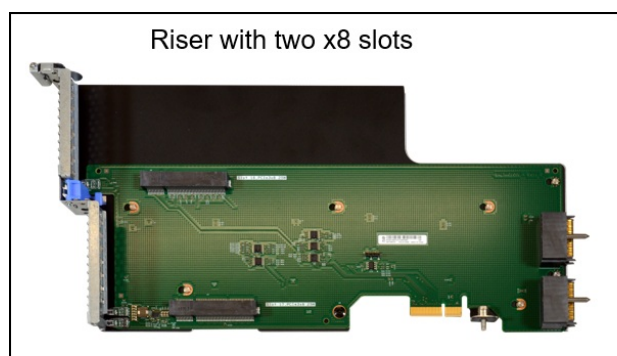

Figure 17. 2x8 riser card

Ordering information for the riser cards is listed in the following table.

Table 29. Riser card ordering information

Part number	Feature code	Description
Riser cards for riser slots 1 and 2		
7XC7A03963	AUN3	ThinkSystem SR950 up to (5) x16 + x16 ML2 PCIe Riser
7XC7A03961	AUN1	ThinkSystem SR950 (2) x16 PCIe Riser
7XC7A03962	AUN2	ThinkSystem SR950 (4) x8 PCIe Riser
Riser card for 2x8 riser slot		
7XC7A03964	AUN4	ThinkSystem SR950 (2) x8 PCIe Riser

Slot availability by server configuration

The riser cards required for each server configuration are listed in the following table. See the [Server configurations](#) section for details.

Table 30. Riser card requirements

Riser	4S Performance	4S Performance/ Storage Rich	4S Upgradeable	4S Upgradeable/ Storage Rich	8S Storage Rich
Riser 1	4x8 or 2x16	4x8 or 2x16	4x8 or 2x16	5x16+ML2*	5x16+ML2*
Riser 2	4x8 or 2x16	4x8 or 2x16	4x8 or 2x16	5x16+ML2*	5x16+ML2*
2x8 Riser	2x8	None	2x8	2x8	2x8

* If desired, the 4x8 or 2x16 riser cards can be used instead of the 5x16+ML2 riser, with reduced slot availability

Based on these riser card requirements, the available slots for each server configuration are highlighted with a grey background in the following table. The table also lists the processor that each PCIe slot is connected to, based on the server configuration selected. In the table, NC means not connected.

Processor numbering is shown in [Figure 7](#).

Table 31. Processor connectivity for PCIe slots (NC = not connected)

Configuration	Slot location	4S Performance	4S Performance/ Storage Rich	4S Upgradable	4S Upgradable/ Storage Rich	8S Storage Rich
Processors installed		1,2 or 1,2,3,4	1,2,3,4	1,2 or 1,2,3,4	1,2,5,6	1,2,3,4,5,6,7,8
Slot 1	Riser 1	4** (NC for 2x16)*	4 (NC for 2x16)*	4** (NC for 2x16)*	NC	8
Slot 2		4** (NC for 2x16)*	4 (NC for 2x16)*	4** (NC for 2x16)*	NC	8
Slot 3		4**	4	4**	6	6
Slot 4		4**	4	4**	6	6
Slot 5	I/O Tray	2	2	2	2	2
Slot 6	I/O Tray	2	2	2	2	2
Slot 7	I/O Tray	1	1	1	1	1
Slot 8 (ML2)	I/O Tray	1	1	1	1	1
Slot 9 (LOM)	I/O Tray	1 (PCH)	1 (PCH)	1 (PCH)	1 (PCH)	1 (PCH)
Slot 10	Riser 2	3	3	3	NC	7
Slot 11		3	3	3	NC	7
Slot 12		3	3	3	5	5
Slot 13		3	3	3	5	5
Slot 14		NC	NC	NC	NC	3
Slot 15 (ML2)		NC	NC	NC	NC	3
Slot 16	2x8 Riser	3**	NC	3**	NC	3
Slot 17	Riser	1	NC	1	1	1
M.2 slot	I/O Tray	1 (PCH)	1 (PCH)	1 (PCH)	1 (PCH)	1 (PCH)
Storage adapter slot	Upper tray	NC	1	NC	5	5
Storage adapter slot	Lower tray	1	1	1	1	1

* Slots 1 and 2 are not connected if the 2x16 riser card is used in riser slot 1

** In 2-processor configurations, processors 3 and 4 are not installed; this means slots 1-4 and slot 16 are not connected

Network adapters

The SR950 has an integrated 10Gb Ethernet controller, based on the Intel Ethernet Connection X722. The X722 has the following features:

- Integrated into the Intel PCH chipset
- Supports 1GbE or 10GbE connections, depending on the selected LOM Phy adapter
- Offers VXLAN/NVGRE hardware offloads
- Supports VMDq and SR-IOV for advanced virtualization
- Supports iWarp RDMA

To provide connectivity to the X722, the SR950 supports six different LOM (LAN on Motherboard) cards which provide the Ethernet PHY function. Only 1 LOM card can be installed. See [Figure 3](#) for the location of the LOM slot.

The LOM card supports NC-SI to allow the network connection to be shared between the operating system and the XClarity Controller (XCC) management module. The LOM also supports Wake-on-LAN (WOL).

For more information about the X722 controller, see the Lenovo Press product guide: <http://lenovopress.com/lp0654-intel-x722-integrated-controller>

The following table lists the supported LOM cards.

Note: None of the LOM cards listed in the table support speeds lower than 1 Gbps.

Table 32. Supported LOM adapters

Part number	Feature code	Description	Ports	Slots supported	Maximum supported
Gigabit Ethernet					
7ZT7A00544	AUKG	ThinkSystem 1Gb 2-port RJ45 LOM	2x RJ45	7	1
7ZT7A00545	AUKH	ThinkSystem 1Gb 4-port RJ45 LOM	4x RJ45	7	1
10 Gb Ethernet					
7ZT7A00546	AUKJ	ThinkSystem 10Gb 2-port SFP+ LOM	2x SFP+ bays	7	1
7ZT7A00547	AUKK	ThinkSystem 10Gb 4-port SFP+ LOM	4x SFP+ bays	7	1
7ZT7A00548	AUKL	ThinkSystem 10Gb 2-port Base-T LOM	2x RJ45 (10GBASE-T)	7	1
7ZT7A00549	AUKM	ThinkSystem 10Gb 4-port Base-T LOM	4x RJ45 (10GBASE-T)	7	1

The SR950 also support one ML2 card for 4-socket configurations (slot 8). For 8-socket servers using the 5x16 ML2 riser, the server has two ML2 slots - slot 8 and slot 15. See the [I/O expansion options section](#) for details.

The ML2 card in slot 8 supports NC-SI however the ML2 card in slot 15 does not support NC-SI.

The following table lists the supported ML2 adapters.

Table 33. Supported ML2 adapters

Part number	Feature code	Description	Bus width	Slots supported	Maximum supported†
Gigabit Ethernet					
7ZT7A00536	AUKW	ThinkSystem Intel I350-T4 ML2 1Gb 4-Port RJ45 Ethernet Adapter	PCIe 3.0 x8	8, 15	1 / 2
10 Gb Ethernet					
00JY940	ATRH	Intel X710-DA2 ML2 2x10GbE SFP+ Adapter	PCIe 3.0 x8	8, 15	1 / 2
7ZT7A00497	AUKQ	ThinkSystem Broadcom NX-E ML2 10Gb 2-Port Base-T Ethernet Adapter	PCIe 3.0 x8	8, 15	1 / 2
00AG560*	AT7U	Emulex VFA5.2 ML2 Dual Port 10GbE SFP+ Adapter	PCIe 3.0 x8	8, 15	1 / 2
01CV770	AU7Z	Emulex VFA5.2 ML2 2x10 GbE SFP+ Adapter and FCoE/iSCSI SW	PCIe 3.0 x8	8, 15	1 / 2
25 Gb Ethernet					
7ZT7A00507	AUKU	ThinkSystem Mellanox ConnectX-4 Lx ML2 25Gb 2-Port SFP28 Ethernet Adapter	PCIe 3.0 x8	8, 15	1 / 2
00MN990	ATZR	Mellanox ConnectX-4 Lx ML2 1x25GbE SFP28 Adapter	PCIe 3.0 x8	8, 15	1 / 2
InfiniBand					
7ZT7A00501	AUKR	ThinkSystem Mellanox ConnectX-3 Pro ML2 FDR 2-Port QSFP VPI Adapter	PCIe 3.0 x8	8, 15	1 / 2

* ThinkSystem servers do not support Features on Demand, so the Emulex VFA5.2 ML2 Dual Port 10GbE SFP+ Adapter, 00AG560, cannot be upgraded to FCoE support. If you need FCoE or iSCSI support, use 01CV770 instead.

† Two ML2 adapters are supported with an 8-socket configuration if the 5x16+ML2 riser is installed in riser slot 2.

The following table lists additional supported network adapters that can be installed in the regular PCIe slots.

Table 34. Supported PCIe Network Adapters

Part number	Feature code	Description	Slots supported	Maximum supported
10 Gb Ethernet - 10GBase-T				
7ZT7A00496	AUKP	ThinkSystem Broadcom NX-E PCIe 10Gb 2-Port Base-T Ethernet Adapter	1-7, 10-14, 16-17	14
00MM860	ATPX	Intel X550-T2 Dual Port 10GBase-T Adapter	1-7, 10-14, 16-17	14
10 Gb Ethernet - SFP+				
7ZT7A00537	AUKX	ThinkSystem X710-DA2 PCIe 10Gb 2-Port SFP+ Ethernet Adapter	1-7, 10-14, 16-17	14
7ZT7A00493	AUKN	ThinkSystem Emulex OCe14104B-NX PCIe 10Gb 4-Port SFP+ Ethernet Adapter	1-4, 10-14	9
00AG570*	AT7S	Emulex VFA5.2 2x10 GbE SFP+ PCIe Adapter	1-7, 10-14, 16-17	14
00AG580	AT7T	Emulex VFA5.2 2x10 GbE SFP+ Adapter and FCoE/iSCSI SW	1-7, 10-14, 16-17	14
25 Gb Ethernet				
7ZT7A00505	AUKS	ThinkSystem Broadcom NX-E PCIe 25Gb 1-Port SFP28 Ethernet Adapter	1-7, 10-14, 16-17	14
01GR250	AUAJ	Mellanox ConnectX-4 Lx 2x25GbE SFP28 Adapter	1-7, 10-14, 16-17	14
40 Gb Ethernet				
00MM950	ATRN	Mellanox ConnectX-4 Lx 1x40GbE QSFP+ Adapter	1-7, 10-14, 16-17	14
100 Gb Ethernet				
00MM960	ATRP	Mellanox ConnectX-4 2x100GbE/EDR IB QSFP28 VPI Adapter	1-6, 10-14	11
InfiniBand				
7ZT7A00500	AUVG	ThinkSystem Mellanox ConnectX-4 PCIe FDR 2-Port QSFP VPI Adapter	1-7, 10-14, 16-17	14

* ThinkSystem servers do not support Features on Demand, so the Emulex VFA5.2 2x10 GbE SFP+ PCIe Adapter, 00AG570, cannot be upgraded to FCoE support. If you need FCoE or iSCSI support, use 00AG580 instead.

For more information, see the list of Lenovo Press Product Guides in the Networking adapters category: <https://lenovopress.com/servers/options/ethernet>

Transceivers and DAC cables

The following table lists the supported 10 Gb Ethernet SFP+ optical transceivers and DAC cables. For multi-port adapters, all adapter ports must have the same type of transceiver or DAC cable selected.

Table 35. Supported optical transceivers and DAC cables - 10 Gb Ethernet

Part number	Feature code	Description
10 GbE SFP+ transceivers (for 10 GbE SFP+ adapters)		
46C3447	5053	Lenovo 10GBASE-SR SFP+ Transceiver
49Y4216	0069	Brocade 10Gb SFP+ SR Optical Transceiver
49Y4218	0064	QLogic 10Gb SFP+ SR Optical Transceiver
10 GbE SFP+ DAC cables (for 10 GbE SFP+ adapters)		
00D6288	A3RG	Lenovo 0.5m Passive SFP+ DAC Cable
90Y9427	A1PH	Lenovo 1m Passive SFP+ DAC Cable
00AY764	A51N	Lenovo 1.5m Passive SFP+ DAC Cable
00AY765	A51P	Lenovo 2m Passive SFP+ DAC Cable
90Y9430	A1PJ	Lenovo 3m Passive SFP+ DAC Cable
90Y9433	A1PK	Lenovo 5m Passive SFP+ DAC Cable
00D6151	A3RH	Lenovo 7m Passive SFP+ DAC Cable

The following table lists the supported 25 GbE transceiver and DAC cables. For multi-port adapters, all adapter ports must have the same type of transceiver or DAC cable selected.

Table 36. Supported optical transceivers and DAC cables - 25 Gb Ethernet

Part number	Feature code	Description
25 GbE SFP28 transceiver		
7G17A03537	AV1B	Lenovo 25GBase-SR SFP28 Transceiver
25 GbE SFP28 DAC cables		
7Z57A03557	AV1W	Lenovo 1m Passive 25G SFP28 DAC Cable
7Z57A03558	AV1X	Lenovo 3m Passive 25G SFP28 DAC Cable
7Z57A03559	AV1Y	Lenovo 5m Passive 25G SFP28 DAC Cable

The following table lists the optical transceivers and DAC cables that can be used with the supported 40Gb Ethernet adapters listed. For multi-port adapters, all adapter ports must have the same type of transceiver or DAC cable selected.

Table 37. Supported optical transceivers and DAC cables - 40 Gb Ethernet

Part number	Feature code	Description
40 GbE QSFP+ transceivers (for 40 GbE QSFP+ adapters)		
49Y7884	A1DR	Lenovo 40GBASE-SR4 QSFP+ Transceiver
40 GbE QSFP+ DAC cables (for 40 GbE QSFP+ adapters)		
49Y7890	A1DP	Lenovo 1m Passive QSFP+ DAC Cable
49Y7891	A1DQ	Lenovo 3m Passive QSFP+ DAC Cable

The following table lists the supported 100 Gb Ethernet SFP+ optical transceivers and DAC cables. For multi-port adapters, all adapter ports must have the same type of transceiver or DAC cable selected.

Table 38. Supported optical transceivers and DAC cables - 100 Gb Ethernet

Part number	Feature code	Description
100 GbE QSFP28 transceivers		
7G17A03539	AV1D	Lenovo 100GBase-SR4 QSFP28 Transceiver
100 GbE QSFP28 Active Optical Cables		
7Z57A03546	AV1L	Lenovo 3m 100G QSFP28 Active Optical Cable
7Z57A03547	AV1M	Lenovo 5m 100G QSFP28 Active Optical Cable
7Z57A03548	AV1N	Lenovo 10m 100G QSFP28 Active Optical Cable
7Z57A03549	AV1P	Lenovo 15m 100G QSFP28 Active Optical Cable
7Z57A03550	AV1Q	Lenovo 20m 100G QSFP28 Active Optical Cable
100 GbE SFP28 DAC cables		
7Z57A03561	AV1Z	Lenovo 1m Passive 100G QSFP28 DAC Cable
7Z57A03562	AV20	Lenovo 3m Passive 100G QSFP28 DAC Cable
7Z57A03563	AV21	Lenovo 5m Passive 100G QSFP28 DAC Cable
100G-to-4x25G Breakout cables		
7Z57A03564	AV22	Lenovo 1m 100G QSFP28 to 4x25G SFP28 Breakout DAC Cable
7Z57A03565	AV23	Lenovo 3m 100G QSFP28 to 4x25G SFP28 Breakout DAC Cable
7Z57A03566	AV24	Lenovo 5m 100G QSFP28 to 4x25G SFP28 Breakout DAC Cable

Fibre Channel host bus adapters

The following table lists the Fibre Channel HBAs supported by SR950.

Table 39. Fibre Channel HBAs

Part number	Feature code	Description	Slots supported	Maximum supported
32 Gb Fibre Channel HBAs				
7ZT7A00516	AUNS	ThinkSystem QLogic QLE2740 PCIe 32Gb 1-Port SFP+ Fibre Channel Adapter	1-7, 10-14, 16-17	14
7ZT7A00518	AUNU	ThinkSystem QLogic QLE2742 PCIe 32Gb 2-Port SFP+ Fibre Channel Adapter	1-7, 10-14, 16-17	14
7ZT7A00519	AUNV	ThinkSystem Emulex LPe32002-M2-L PCIe 32Gb 2-Port SFP+ Fibre Channel Adapter	1-7, 10-14, 16-17	14
7ZT7A00517	AUNT	ThinkSystem Emulex LPe32000-M2-L PCIe 32Gb 1-Port SFP+ Fibre Channel Adapter	1-7, 10-14, 16-17	14
16 Gb Fibre Channel HBAs				
01CV750	ATZB	QLogic 16Gb Enhanced Gen5 FC Single-port HBA	1-7, 10-14, 16-17	14
01CV760	ATZC	QLogic 16Gb Enhanced Gen5 FC Dual-port HBA	1-7, 10-14, 16-17	14
01CV830	ATZU	Emulex 16Gb Gen6 FC Single-port HBA	1-7, 10-14, 16-17	14
01CV840	ATZV	Emulex 16Gb Gen6 FC Dual-port HBA	1-7, 10-14, 16-17	14

For more information, see the list of Lenovo Press Product Guides in the Host bus adapters category:

<https://lenovopress.com/servers/options/hba>

SAS adapters for external storage

The following table lists SAS HBAs and RAID adapters supported by SR950 server for use with external storage.

Table 40. Adapters for external storage

Part number	Feature code	Description	Slots supported	Maximum supported
SAS HBAs				
7Y37A01090	AUNR	ThinkSystem 430-8e SAS/SATA 12Gb HBA	1-7, 10-14, 16-17	14
7Y37A01091	AUNN	ThinkSystem 430-16e SAS/SATA 12Gb HBA	1-7, 10-14, 16-17	14
External RAID adapters				
7Y37A01087	AUNQ	ThinkSystem RAID 930-8e 4GB Flash PCIe 12Gb Adapter	1-7, 10-14, 16-17	Four*

* Maximum is 4 adapters because there are only 4 supercap holders in the server, mounted on the side of the two riser cards.

For more information, see the list of Lenovo Press Product Guides in the Host bus adapters and RAID adapters categories:

<https://lenovopress.com/servers/options/hba>

<https://lenovopress.com/servers/options/raid>

The following table compares the specifications of the external SAS HBAs and RAID adapters.

Table 41. Comparison of external storage adapters

Feature	430-8e	430-16e	930-8e
Adapter type	HBA	HBA	External RAID
Part number	7Y37A01090	7Y37A01091	7Y37A01087
Controller chip	LSI SAS3408	LSI SAS3416	LSI SAS3508
Broadcom equivalent	HBA 9400-8e	HBA 9400-16e	MegaRAID 9480-8e
Host interface	PCIe 3.0x8	PCIe 3.0x8	PCIe 3.0x8
Port interface	12 Gb SAS	12 Gb SAS	12 Gb SAS
Number of ports	8	16	8
Port connectors	2x Mini-SAS HD SFF8644	4x Mini-SAS HD SFF8644	2x Mini-SAS HD SFF8644
Drive interface	SAS/SATA	SAS/SATA	SAS,SATA
Drive type	HDD/SSD/SED*	HDD/SSD/SED*	HDD,SED,SSD
Hot-swap drives	Yes	Yes	Yes
Maximum devices	512 (planned: 1024)	512 (planned: 1024)	64 (planned: 216)
RAID levels	None	None	0/1/10/5/50/6/60
JBOD mode	Yes	Yes	Yes
Cache	None	None	4GB (Standard)
CacheVault cache protection	None	None	Yes (Flash)
Performance Accelerator (FastPath)	No	No	Yes
SSD Caching (CacheCade Pro 2.0)	No	No	No
SED support*	Yes	Yes	Yes

* SED support of the SAS HBAs is by using software on the server (SED commands are passed through the HBA to the drives). SED support by RAID controllers is provided using the built-in MegaRAID SafeStore functionality of the adapter.

Flash Storage adapters

The server supports the PCIe Flash Storage adapters listed in the following table.

Table 42.

Part number	Feature code	Description	Slots supported	Maximum supported
7N47A00097	AUUP	ThinkSystem HHHH PX04PMC 1.92TB Mainstream NVMe PCIe 3.0 x4 Flash Adapter	1-7, 10-14, 16-17	14
7N47A00098	AUVY	ThinkSystem HHHH PX04PMC 3.84TB Mainstream NVMe PCIe 3.0 x4 Flash Adapter	1-7, 10-14, 16-17	14
7XB7A05925	AWG8	ThinkSystem HHHH PX04PMC 1.6TB Performance NVMe PCIe 3.0 x4 Flash Adapter	1-7, 10-14, 16-17	14
7XB7A05924	AWG9	ThinkSystem HHHH PX04PMC 3.2TB Performance NVMe PCIe 3.0 x4 Flash Adapter	1-7, 10-14, 16-17	14

For details about these adapters, see the Lenovo Press product guides in the Flash Adapters category: <https://lenovopress.com/servers/options/ssdadapter>

GPU adapters and coprocessors

Full-length adapter cards such as graphics processing units (GPUs) do not physically fit in the server and are not supported.

Cooling

The SR950 uses a set of 60mm hot-swap single-rotor fans for system-wide cooling. Each compute tray or storage tray houses 6 hot-swap fans. The 6 fans in the compute tray are N+1 redundant, meaning that a single fan failure is tolerated in each compute tray.

Fans are located internal to the server immediately in front of the compute system boards, but are accessible from the front of the server by the long handle attached to the fan. As the handle is pulled out, the attached fan rotates from vertical orientation to horizontal orientation, allowing the fan to be removed from the system using the handle, as shown below.

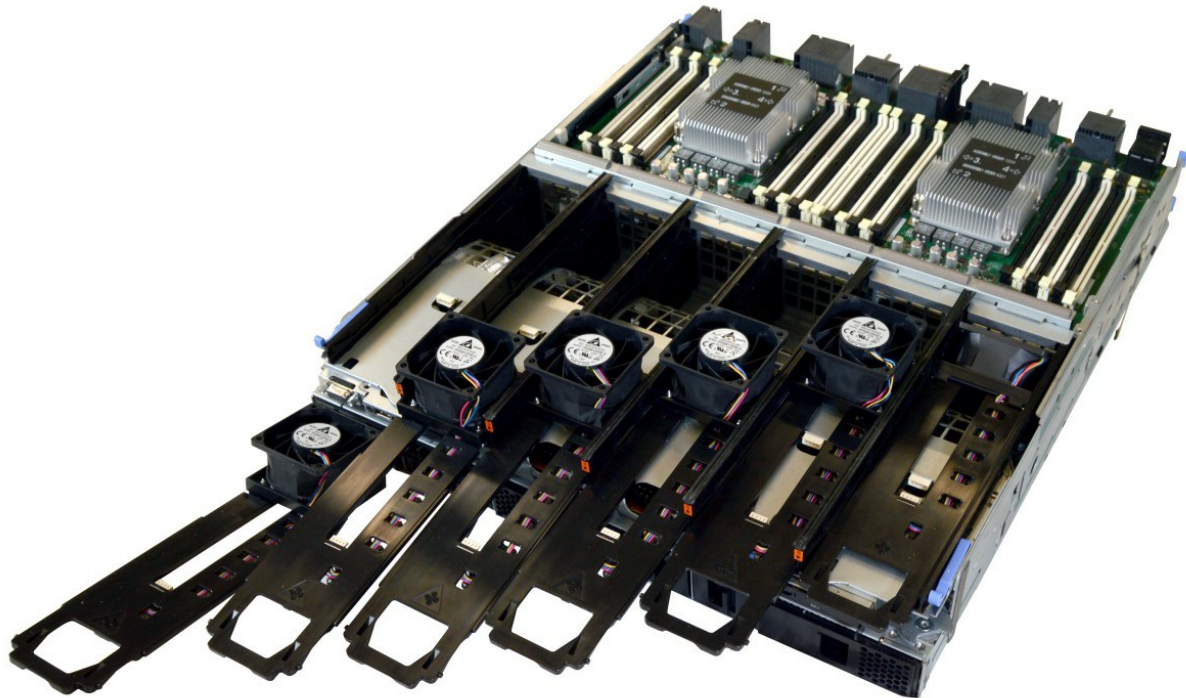

Figure 18. Six fans installed in each compute tray (lower compute tray shown)

Power supplies

The server supports up to four hot-swap power supplies. Power supplies are N+N redundant, which means that if the server has four power supplies installed, then the server can continue operation even with two failed power supplies, or if the utility service that feeds those two power supplies goes offline.

All power supplies installed in a server must have the same capacity (for example all 1600W).

Table 43. Power supply options

Part number	Feature code	Description	Maximum supported	110V AC	220V AC	240V DC China only
7N67A00885	AVNV	1100W Platinum (230V/115V) Power Supply	4	Yes	Yes	No
7N67A00886	AUPT	1600W Platinum (230V) Power Supply	4	No	Yes	No

The 1100W power supply is auto-sensing and supports both 110V AC (100-127V 50/60 Hz) and 220V AC (200-240V 50/60 Hz) power. The 1600 W power supply only supports 220V AC power. 240V DC is not supported.

Note: At 100-127 V AC input, the 1100W power supply is limited to 1050W.

Power supply options do not include a power cord. For models of the SR950, the inclusion of a power cords is model dependent. Configure-to-order models can be configured without a power cord if desired.

Use the Power Configurator to determine exactly what power your server needs:

<https://datacentersupport.lenovo.com/us/en/solutions/Invo-pwrconf>

Power cords

Country-specific line cords and rack power cables can be ordered as listed in the following table.

Table 44. Power cords

Part number	Feature code	Description
Rack cables		
00Y3043	A4VP	1.0m, 10A/100-250V, C13 to C14 Jumper Cord
39Y7937	6201	1.5m, 10A/100-250V, C13 to C14 Jumper Cord
4L67A08369	6570	2.0m, 13A/100-250V, C13 to C14 Jumper Cord
4L67A08366	6311	2.8m, 10A/100-250V, C13 to C14 Jumper Cord
4L67A08370	6400	2.8m, 13A/100-250V, C13 to C14 Jumper Cord
39Y7932	6263	4.3m, 10A/100-250V, C13 to C14 Jumper Cord
4L67A08371	6583	4.3m, 13A/100-250V, C13 to C14 Jumper Cord
Country-specific cables		
39Y7930	6222	2.8m, 10A/250V, C13 to IRAM 2073 (Argentina) Line Cord
81Y2384	6492	4.3m, 10A/250V, C13 to IRAM 2073 (Argentina) Line Cord
39Y7924	6211	2.8m, 10A/250V, C13 to AS/NZS 3112 (Australia/NZ) Line Cord
81Y2383	6574	4.3m, 10A/250V, C13 to AS/NZS 3112 (Australia/NZ) Line Cord
69Y1988	6532	2.8m, 10A/250V, C13 to NBR 14136 (Brazil) Line Cord
81Y2387	6404	4.3m, 10A/250V, C13 to NBR 14136 (Brazil) Line Cord
39Y7928	6210	2.8m, 10A/220V, C13 to GB 2099.1 (China) Line Cord
81Y2378	6580	4.3m, 10A/250V, C13 to GB 2099.1 (China) Line Cord
39Y7918	6213	2.8m, 10A/250V, C13 to DK2-5a (Denmark) Line Cord
81Y2382	6575	4.3m, 10A/250V, C13 to DK2-5a (Denmark) Line Cord
39Y7917	6212	2.8m, 10A/250V, C13 to CEE 7/7 (Europe) Line Cord
81Y2376	6572	4.3m, 10A/250V, C13 to CEE 7/7 (Europe) Line Cord
39Y7927	6269	2.8m, 10A/250V, C13 to IS 6538 (India) Line Cord
81Y2386	6567	4.3m, 10A/250V, C13 to IS 6538 (India) Line Cord
39Y7920	6218	2.8m, 10A/250V, C13 to SI 32 (Israel) Line Cord
81Y2381	6579	4.3m, 10A/250V, C13 to SI 32 (Israel) Line Cord
39Y7921	6217	2.8m, 10A/250V, C13 to CEI 23-16 (Italy) Line Cord
81Y2380	6493	4.3m, 10A/250V, C13 to CEI 23-16 (Italy) Line Cord
4L67A08362	6495	4.3m, 12A/200V, C13 to JIS C-8303 (Japan) Line Cord
39Y7922	6214	2.8m, 10A/250V, C13 to SABS 164-1 (South Africa) Line Cord

Part number	Feature code	Description
81Y2379	6576	4.3m, 10A/250V, C13 to SANS 164-1 (South Africa) Line Cord
39Y7926	6335	4.3m, 12A/100V, C13 to JIS C-8303 (Japan) Line Cord
39Y7925	6219	2.8m, 12A/220V, C13 to KSC 8305 (S. Korea) Line Cord
81Y2385	6494	4.3m, 12A/250V, C13 to KSC 8305 (S. Korea) Line Cord
39Y7919	6216	2.8m, 10A/250V, C13 to SEV 1011-S24507 (Swiss) Line Cord
81Y2390	6578	4.3m, 10A/250V, C13 to SEV 1011-S24507 (Swiss) Line Cord
23R7158	6386	2.8m, 10A/125V, C13 to CNS 10917 (Taiwan) Line Cord
81Y2375	6317	2.8m, 10A/250V, C13 to CNS 10917 (Taiwan) Line Cord
81Y2374	6402	2.8m, 13A/125V, C13 to CNS 10917 (Taiwan) Line Cord
4L67A08363	AX8B	4.3m, 10A/125V, C13 to CNS 10917 (Taiwan) Line Cord
81Y2389	6531	4.3m, 10A/250V, C13 to CNS 10917 (Taiwan) Line Cord
81Y2388	6530	4.3m, 13A/125V, C13 to CNS 10917 (Taiwan) Line Cord
39Y7923	6215	2.8m, 10A/250V, C13 to BS 1363/A (UK) Line Cord
81Y2377	6577	4.3m, 10A/250V, C13 to BS 1363/A (UK) Line Cord
90Y3016	6313	2.8M, 10A/125V, C13 to NEMA 5-15P (US) Line Cord
46M2592	A1RF	2.8m, 10A/250V, C13 to NEMA 6-15P (US) Line Cord
00WH545	6401	2.8M, 13A/125V, C13 to NEMA 5-15P (US) Line Cord
4L67A08359	6370	4.3m, 10A/125V, C13 to NEMA 5-15P (US) Line Cord
4L67A08361	6373	4.3m, 10A/250V, C13 to NEMA 6-15P (US) Line Cord
4L67A08360	AX8A	4.3m, 13A/125V, C13 to NEMA 5-15P (US) Line Cord

110V customers: If you plan to use the ThinkSystem 1100W power supply with a 110V power source, select a power cable that is rated above 10A. Power cables that are rated at 10A or below are not supported with 110V power.

Integrated virtualization

The server supports booting from an operating system or hypervisor installed on an M.2 solid-state drive. See the [M.2 drives section](#) for details and the list of available options.

You can download supported VMware vSphere hypervisor images from the following web page and load it on the M.2 drive using the instructions provided:

http://shop.lenovo.com/us/en/systems/solutions/alliances/vmware/#tab-vmware_vsphere_esxi

Systems management

The server contains an integrated service processor, XClarity Controller (XCC), which provides advanced service-processor control, monitoring, and alerting functions. The XCC is based on the Pilot4 XE401 baseboard management controller (BMC) using a dual-core ARM Cortex A9 service processor.

Local management

The SR950 offers the front operator panel showing key LED status indicators, as shown in the following figure.

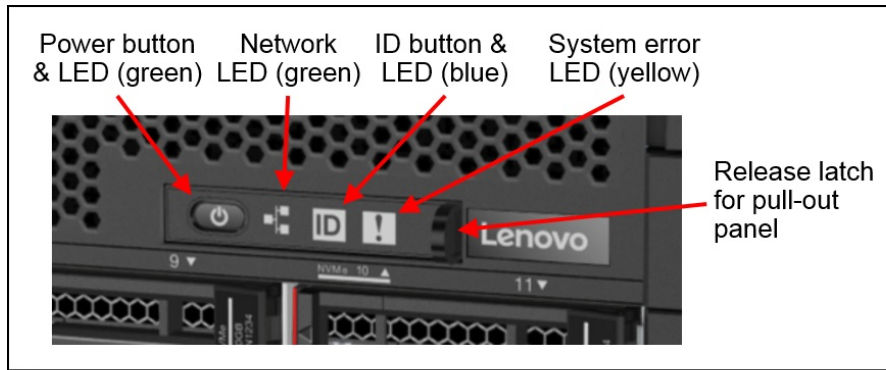

Figure 19. Front operator panel (LCD display panel closed)

The front operator panel pulls out (see the release latch in the above figure) to show an LCD display panel and buttons, as shown in the following figure. The LCD display panel allows quick access to system status, firmware, network, and health information.



Figure 20. LCD display panel

The LCD display and the function buttons give you access to the following information:

- Error messages
- System VPD: machine type & mode, serial number, UUID string
- System firmware levels: UEFI and XCC firmware
- XCC network information: hostname, MAC address, IP address, DNS addresses
- Environmental data: Ambient temperature, CPU temperature, AC input voltage, estimated power consumption
- System reset action

If an environmental condition exceeds a threshold or if a system component fails, XCC lights LEDs inside the server to help you diagnose the problem and find the failing part. The SR950 has fault LEDs next to the following components:

- Each processor
- Each memory DIMM
- Each system fan
- Each power supply
- Each rear-facing PCIe slot
- Each drive bay

For local console use, the SR950 has both a front and rear VGA port. Only one can be active at a time. If displays are connected to both VGA ports, the front VGA port takes precedence.

System status with XClarity Mobile

The XClarity Mobile app now includes a tethering function where you can connect your Android or iOS device to the server via USB to see the status of the server.

The steps to connect the mobile device are as follows:

1. Enable USB Management on the server, by holding down the ID button for 3 seconds (or pressing the dedicated USB management button if one is present)
2. Connect the mobile device via a USB cable to the server's USB port with the management symbol 
3. In iOS or Android settings, enable Personal Hotspot or USB Tethering
4. Launch the Lenovo XClarity Mobile app

Once connected you can see the following information:

- Server status including error logs (read only, no login required)
- Server management functions (XClarity login credentials required)

Remote management

Remote server management is provided through industry-standard interfaces:

- Intelligent Platform Management Interface (IPMI) Version 2.0
- Simple Network Management Protocol (SNMP) Version 3 (no SET commands; no SNMP v1)
- Common Information Model (CIM-XML)
- Representational State Transfer (REST) support
- Redfish support (DMTF compliant)
- Web browser - HTML 5-based browser interface (Java and ActiveX not required) using a responsive design (content optimized for the device being used: laptop, tablet, phone) with NLS support

A virtual presence (remote control and remote media) capability also comes standard in the server for remote server management.

The remote control functions include the following:

- Remotely viewing video with graphics resolutions up to 1600x1200 at 75 Hz with up to 23 bits per pixel, regardless of the system state
- Remotely accessing the server using the keyboard and mouse from a remote client
- Capturing blue-screen errors
- International keyboard mapping support
- LDAP-based authentication
- Optionally, with the XCC Enterprise license upgrade, mapping ISO and diskette IMG image files as virtual drives that are available for use by the server
- Boot Capture
- Remote mounting of ISO and IMG files
- Virtual console collaboration
- Power capping

- License for XClarity Energy Manager

Lenovo XClarity Administrator

Lenovo XClarity Administrator is a centralized resource management solution designed to reduce complexity, speed response, and enhance the availability of Lenovo systems and solutions.

Lenovo XClarity Administrator provides agent-free hardware management for ThinkSystem servers, in addition to ThinkServer, System x, and Flex System servers. The administration dashboard is based on HTML 5 and allows fast location of resources so tasks can be run quickly.

Because Lenovo XClarity Administrator does not require any agent software to be installed on the managed endpoints, there are no CPU cycles spent on agent execution, and no memory is used, which means that up to 1GB of RAM and 1 - 2% CPU usage is saved, compared to a typical managed system where an agent is required.

Lenovo XClarity Administrator provides full management function to ThinkSystem servers, including the following:

- Discovery
- Inventory
- Monitoring and alerting
- Call home
- Centralized user management
- Cryptography modes, server certificates, and encapsulation
- Configuration patterns
- Operating system deployment
- Firmware updates

For more information about Lenovo XClarity Administrator, including ordering part numbers, see the Lenovo XClarity Administrator Product Guide:

<https://lenovopress.com/tips1200-lenovo-xclarity-administrator>

Lenovo XClarity Essentials

Lenovo offers the following XClarity Essentials software tools that can help you set up, use, and maintain the server at no additional cost:

- **Lenovo Essentials OneCLI**
OneCLI is a collection of server management tools that uses a command line interface program to manage firmware, hardware, and operating systems. It provides functions to collect full system health information (including health status), configure system setting, and update system firmware and drivers.
- **Lenovo Essentials UpdateXpress**
The UpdateXpress tool is a standalone GUI application for firmware and device driver updates that enables you to maintain your server firmware and device drivers up-to-date and help you avoid unnecessary server outages. The tool acquires and deploys individual updates and UpdateXpress System Packs (UXSPs) which are integration-tested bundles.
- **Lenovo Essentials Bootable Media Creator**
The Bootable Media Creator (BOMC) tool is used to create bootable media for offline firmware update.

For more information and downloads, visit the Lenovo XClarity Essentials web page:

<http://support.lenovo.com/us/en/documents/LNVO-center>

Lenovo XClarity Energy Manager

Lenovo XClarity Energy Manager is an agent-free, web-based console that provides power management for ThinkSystem servers as well as System x and ThinkServer systems. It enables server density and data center capacity to be increased through the use of power capping.

Lenovo XClarity Energy Manager is a licensed product. A single-node XClarity Energy Manager license is included with the XClarity Controller Enterprise (XCC Enterprise) upgrade as described in the [Remote Management](#) section. If your server does not have the XCC Enterprise upgrade, Energy Manager licenses can be ordered as shown in the following table.

Table 45. Lenovo XClarity Energy Manager

Description	Part number	Maximum supported
4L40E51621	Lenovo XClarity Energy Manager Node License	1 node
4L40E51622	Lenovo XClarity Energy Manager Node License Pack	5 nodes
4L40E51623	Lenovo XClarity Energy Manager Node License Pack	50 nodes

Security

The server offers the following security features:

- Administrator and power-on password
- Trusted Platform Module (TPM) supporting both TPM 1.2 and TPM 2.0
- Optional Trusted Cryptographic Module (TCM), available only in China

The TCM module, available only for China customers, is installed in a dedicated socket on the I/O tray, as shown in [Figure 9](#). Ordering information is shown in the following table.

Table 46. Security features

Part number	Feature code	Description
None*	AVKE	ThinkSystem Trusted Cryptographic Module (China customers only)

* The Trusted Cryptographic Module (TCM) for China customers is not available as a field upgrade. The component is CTO on pre-configured models only.

Rack installation

All models of the SR950 include a rail kit for installation in a 19-inch rack cabinet. The contents of the kits are shown in the following figure.

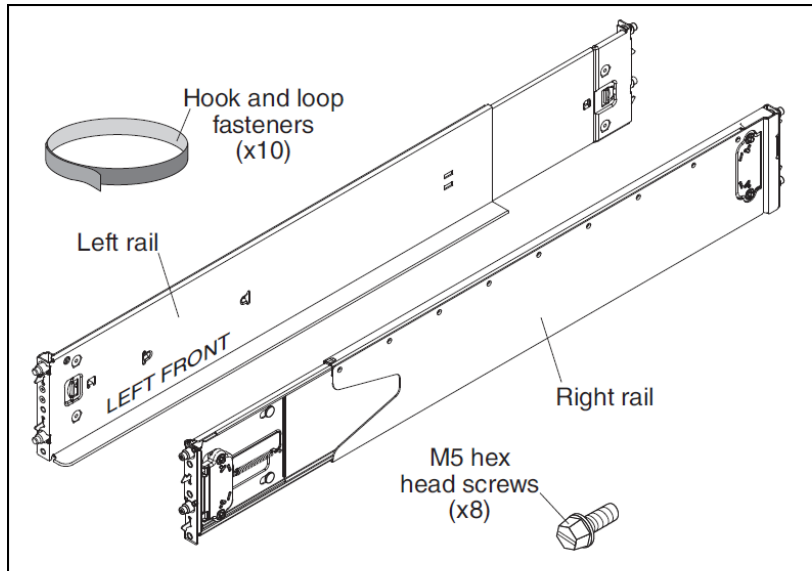

Figure 21. SR950 rail kit

Optionally available is the SR950 shipping bracket kit, which is used when the server is installed in a rack and the complete rack is then shipped to the client.

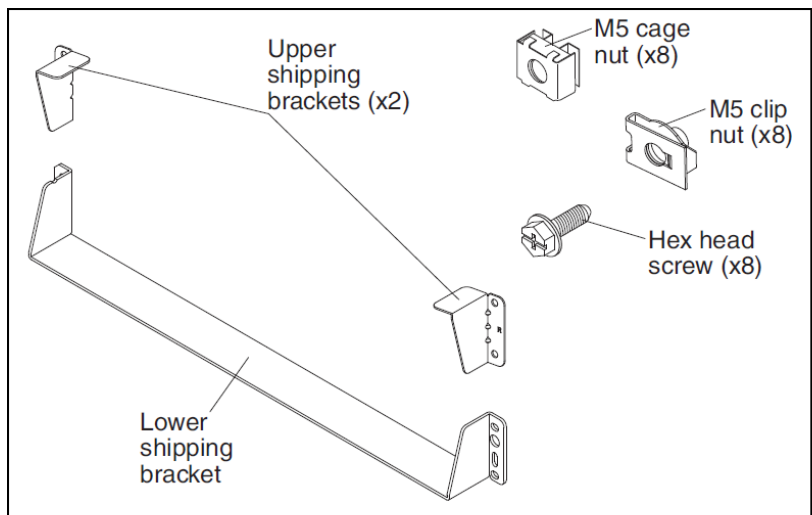

Figure 22. SR950 shipping bracket kit

Table 47. Shipping bracket kit

Part number	Feature code	Description
7XF7A03967	AUL5	ThinkSystem SR950 Shipping Bracket

Operating system support

The SR950 supports the following operating systems

- Microsoft Windows Server 2012 R2
- Microsoft Windows Server 2016
- SUSE LINUX Enterprise Server 11 for AMD64/EM64T
- SUSE LINUX Enterprise Server 11 with Xen for AMD64/EM64T
- Red Hat Enterprise Linux 6 Server x64 Edition
- Red Hat Enterprise Linux 7
- SUSE Linux Enterprise Server 12
- SUSE Linux Enterprise Server 12 with XEN
- VMware vSphere ESXi 6.0
- VMware vSphere ESXi 6.5

For the latest information about the specific versions and service levels that are supported and any other prerequisites, see the Operating System Interoperability Guide, <http://lenovopress.com/osig>

For configure-to-order configurations, the server can be preloaded with VMware ESXi installed on M.2 cards. Ordering information is listed in the following table.

Table 48. VMware ESXi preload

Part number	Feature code	Description
CTO only	AXFT	VMware ESXi 6.5 (factory installed)
CTO only	AXFS	VMware ESXi 6.0 U3 (factory installed)

Physical and electrical specifications

Dimensions and weight:

- Height: 173 mm (6.8 in.)
- Depth:
 - EIA flange to rear: 800.0 mm (31.5 in.)
 - Overall: 835.0 mm (32.9 in.)
- Width:
 - Top cover: 447.0 mm (17.6 in.)
 - EIA flange: 482.0 mm (19.0 in.)
- Weight:
 - Minimum configuration: 32.6 kg (71.9 lb)
 - Maximum configuration: 58.7 kg (129.4 lb)

Electrical:

- Models with 1600 W AC power supplies:
 - 200 - 240 (nominal) V AC; 50 Hz or 60 Hz; 9.0 A
 - Input kilovolt-amperes (kVA) (approximately):
 - Minimum configuration: 0.16 kVA
 - Maximum configuration: 7.2 kVA
- Models with 1100 W AC power supplies:
 - 100 - 127 (nominal) V AC; 50 Hz or 60 Hz; 11.9 A
 - 200 - 240 (nominal) V AC; 50 Hz or 60 Hz; 6.2 A
 - Input kilovolt-amperes (kVA) (approximately):
 - Minimum configuration: 0.12 kVA
 - Maximum configuration: 4.9 kVA

Operating environment

The ThinkSystem SR950 server is designed to ensure thermal compliance to ASHRAE A4 ambient environments, however certain processor models and other components will limit support to only ASHRAE A2 conditions, as shown in the following table. Further, some high-end processors (as indicated with an * in the table) when used in an eight-socket configuration may experience a slight drop in performance under extreme workloads when the ambient temperature is above 30°C.

The following restrictions also apply regarding ASHRAE A3 and A4 support:

- NVMe drives and adapters are supported up to 35°C only

Table 49. ASHRAE support by processor

Processor	ASHRAE A2 support	ASHRAE A3 support	ASHRAE A4 support
Intel Xeon Gold 5115 10C 85W 2.4GHz Processor	Yes	Yes	Yes
Intel Xeon Gold 5118 12C 105W 2.3GHz Processor	Yes	Yes	Yes
Intel Xeon Gold 5120 14C 105W 2.2GHz Processor	Yes	Yes	Yes
Intel Xeon Gold 5120T 14C 105W 2.2GHz Processor	Yes	Yes	Yes
Intel Xeon Gold 5122 4C 105W 3.6GHz Processor	Yes	Yes	Yes
Intel Xeon Gold 6126 12C 125W 2.6GHz Processor	Yes	Yes	Yes
Intel Xeon Gold 6126T 12C 125W 2.6GHz Processor	Yes	Yes	Yes
Intel Xeon Gold 6128 6C 115W 3.4GHz Processor	Yes	Yes	Yes
Intel Xeon Gold 6130 16C 125W 2.1GHz Processor	Yes	Yes	Yes
Intel Xeon Gold 6130T 16C 125W 2.1GHz Processor	Yes	Yes	Yes
Intel Xeon Gold 6132 14C 140W 2.6GHz Processor	Yes	Yes	Yes
Intel Xeon Gold 6134 8C 130W 3.2GHz Processor	Yes	Yes	Yes
Intel Xeon Gold 6134M 8C 130W 3.2GHz Processor	Yes	Yes	Yes
Intel Xeon Gold 6136 12C 150W 3.0GHz Processor	Yes	No	No
Intel Xeon Gold 6138 20C 125W 2.0GHz Processor	Yes	Yes	Yes
Intel Xeon Gold 6138T 20C 125W 2.0GHz Processor	Yes	Yes	Yes
Intel Xeon Gold 6140 18C 140W 2.3GHz Processor	Yes	Yes	Yes
Intel Xeon Gold 6140M 18C 140W 2.3GHz Processor	Yes	Yes	Yes
Intel Xeon Gold 6142 16C 150W 2.6GHz Processor	Yes	No	No
Intel Xeon Gold 6142M 16C 150W 2.6GHz Processor	Yes	No	No
Intel Xeon Gold 6148 20C 150W 2.4GHz Processor	Yes	No	No
Intel Xeon Gold 6150 18C 165W 2.7GHz Processor	Yes	No	No
Intel Xeon Gold 6152 22C 140W 2.1GHz Processor	Yes	Yes	Yes
Intel Xeon Gold 6154 18C 200W 3.0GHz Processor	Yes		
Intel Xeon Platinum 8153 16C 125W 2.0GHz Processor	Yes	Yes	Yes
Intel Xeon Platinum 8156 4C 105W 3.6GHz Processor	Yes	Yes	Yes
Intel Xeon Platinum 8158 12C 150W 3.0GHz Processor	Yes	No	No
Intel Xeon Platinum 8160 24C 150W 2.1GHz Processor	Yes	No	No
Intel Xeon Platinum 8160M 24C 150W 2.1GHz Processor	Yes	No	No
Intel Xeon Platinum 8160T 24C 150W 2.1GHz Processor	Yes	No	No
Intel Xeon Platinum 8164 26C 150W 2.0GHz Processor	Yes	No	No

Processor	ASHRAE A2 support	ASHRAE A3 support	ASHRAE A4 support
Intel Xeon Platinum 8168 24C 205W 2.7GHz Processor	Yes*	No	No
Intel Xeon Platinum 8170 26C 165W 2.1GHz Processor	Yes	No	No
Intel Xeon Platinum 8170M 26C 165W 2.1GHz Processor	Yes	No	No
Intel Xeon Platinum 8176 28C 165W 2.1GHz Processor	Yes	No	No
Intel Xeon Platinum 8176M 28C 165W 2.1GHz Processor	Yes	No	No
Intel Xeon Platinum 8180 28C 205W 2.5GHz Processor	Yes*	No	No
Intel Xeon Platinum 8180M 28C 205W 2.5GHz Processor	Yes*	No	No

* These processors when used in an eight-socket configuration may experience a slight drop in performance under extreme workloads when the ambient temperature is above 30°C.

The server is supported operating in the following environments:

- ASHRAE A2:
 - Temperature: 10°C to 35°C
 - Humidity: 20% to 80%
 - Altitude 0-3000 m (10,000 ft), derated 1°C per 300 m above 950 m
- ASHRAE A3:
 - Temperature: 5°C to 40°C
 - Humidity: 8% to 85%
 - Altitude 0-3000 m (10,000 ft), derated 1°C per 175 m above 950 m
- ASHRAE A4:
 - Temperature: 5°C to 45°C
 - Humidity: 8% to 90%
 - Altitude 0-3000 m (10,000 ft), derated 1°C per 125 m above 950 m

Non-operating environment support:

- Without packaging:
 - Temperature: -10 °C to 60 °C
 - Humidity: 8 to 90%
- Storage with packaging:
 - Temperature: -40 °C to 70 °C
 - Humidity: 8 to 90%

The server generates the following heat:

- Thermal/heat output:
 - Minimum configuration: 938 BTU/hr, 275 W
 - Typical configuration: 3412 BTU/hr, 1000 W
 - Full configuration: 11,970 BTU/hr, 3508 W

Warranty options

The ThinkSystem SR950 server has the following choice of warranties:

- Machine type 7X11: 1-year warranty
- Machine type 7X12: 3-year warranty
- Machine type 7X13: 3-year warranty

The standard warranty terms are customer-replaceable unit (CRU) and onsite (for field-replaceable units, FRUs, only) with standard call center support during normal business hours and 9x5 Next Business Day Parts Delivered.

Also available are Lenovo Services warranty maintenance upgrades and post-warranty maintenance agreements, with a predefined scope of services, including service hours, response time, term of service, and service agreement terms and conditions.

Lenovo warranty service upgrade offerings are country-specific. Not all warranty service upgrades are available in every country. For more information about Lenovo warranty service upgrade offerings that are available in your country, go to the Data Center Advisor and Configurator (formerly known as LESC) website <http://lesc.lenovo.com>, then do the following:

1. In the Customize a Model box in the middle of the page, select the **Services** option in the Customization Option dropdown menu
2. Enter the machine type & model of the system
3. From the search results, you can click either **Deployment Services** or **Support Services** to view the offerings

The following table explains warranty service definitions in more detail.

Table 50. Warranty service definitions

Term	Description
Onsite Service	If a problem with your product cannot be resolved via telephone, a Service Technician will be dispatched to arrive at your location.
Parts Delivered	If a problem with your product cannot be resolved via telephone and a CRU part is required, Lenovo will send a replacement CRU to arrive at your location. If a problem with your product cannot be resolved via telephone and a FRU part is required, a Service Technician will be dispatched to arrive at your location.
Technician Installed Parts	If a problem with your product cannot be resolved via telephone, a Service Technician will be dispatched to arrive at your location.
Hours of coverage	<ul style="list-style-type: none"> • 9x5: 9 hours/day, 5 days/week, during normal business hours, excluding local public & national holidays • 24x7: 24 hours per day, 7 days per week, 365 days per year.
Response time target	2 hours, 4 hours, or Next Business Day: The time period from when the telephone based troubleshooting is completed and logged, to the delivery of the CRU or arrival of a Service Technician and part at the Customer's location for repair.
Committed Repair	6 hours: The time period between the service request registration in Lenovo's call management system and the restoration of the product to conformance with its specification by a Service Technician.

The following Lenovo warranty service upgrades are available:

- Warranty and maintenance service upgrades:
 - Three, four, or five years of 9x5 or 24x7 service coverage
 - Parts delivered or technician installed parts from next business day to 4 or 2 hours
 - Committed repair service
 - Warranty extension of up to 5 years
 - Post warranty extensions

- Committed Repair Service

Committed Repair Services enhances the level of Warranty Service Upgrade or Post Warranty/Maintenance Service offering associated with the selected systems. Offerings vary and are available in select countries.

- Priority handling to meet defined time frames to restore the failing machine to good working condition
- 24x7x6 committed repair: Service performed 24 hours per day, 7 days per week, within 6 hours

- YourDrive YourData

Lenovo's YourDrive YourData service is a multi-drive retention offering that ensures your data is always under your control, regardless of the number of drives that are installed in your Lenovo server. In the unlikely event of a drive failure, you retain possession of your drive while Lenovo replaces the failed drive part. Your data stays safely on your premises, in your hands. The YourDrive YourData service can be purchased in convenient bundles with Lenovo warranty upgrades and extensions.

- Microcode Support

Keeping microcode current helps prevent hardware failures and security exposure. There are two levels of service: analysis of the installed base and analysis and update where required. Offerings vary by country and can be bundled with other warranty upgrades and extensions.

- Enterprise Software Support

Lenovo Enterprise Server Software Support can help you troubleshoot your entire server software stack. Choose support for server operating systems from Microsoft, Red Hat, SUSE, and VMware; Microsoft server applications; or both operating systems and applications. Support staff can help answer troubleshooting and diagnostic questions, address product compatibility and interoperability issues, isolate causes of problems, report defects to software vendors, and more.

In addition, you can access hardware "how to" support for ThinkSystem servers. Staff can help resolve hardware problems not covered under warranty, refer you to the right documentation and publications, provide corrective service information for known defects, and transfer you to a hardware support call center if needed.

- Hardware Installation Services

Lenovo experts can seamlessly manage the physical installation of your server, storage, or networking hardware. Working at a time convenient for you (business hours or off shift), the technician will unpack and inspect the systems on your site, install options, mount in a rack cabinet, connect to power and network, check and update firmware to the latest levels, verify operation, and dispose of the packaging, allowing your team to focus on other priorities. Your new systems will be configured and ready for your software installation.

Regulatory compliance

The SR950 server conforms to the following regulations:

- FCC - Verified to comply with Part 15 of the FCC Rules, Class A
- Canada ICES-003, issue 6, Class A
- UL/IEC 60950-1
- CSA C22.2 No. 60950-1
- IEC 62368-1 2014(CB Certificate and CB Test Report)
- NOM-019
- Argentina IEC60950-1
- Japan VCCI, Class A
- Australia/New Zealand AS/NZS CISPR 32, Class A; AS/NZS 60950.1
- China CCC GB4943.1, GB9254 Class A, GB17625.1
- Taiwan BSMI CNS13438, Class A; CNS14336-1 CNS15663
- Korea KN32, Class A; KN35
- Russia, Belorussia and Kazakhstan, TR CU 020/2011 (for EMC) and TR CU 004/2011 (for safety)
- IEC 60950-1 (CB Certificate and CB Test Report)
- CE Mark (EN55032 Class A, EN60950-1, EN55024, EN61000-3-2, EN61000-3-3)
- CISPR 32, Class A
- TUV-GS (EN60950-1 /IEC60950-1,EK1-ITB2000)
- RoHS Directive
- Energy Star 2.1
- ErP lot3
- JESL

External drive enclosures

The server supports attachment to external drive enclosures using a RAID controller with external ports or a SAS host bus adapter. Adapters supported by the server are listed in the [SAS adapters for external storage](#) section.

The following table lists the 6 Gbps SAS external drive enclosures that are offered by Lenovo that can be used with the server for storage expansion.

Table 51. E1012 and E1024 external drive enclosure models

Part number	Description
64111B1	Lenovo Storage E1012 LFF Disk Expansion Single SAS IO Module, Rail Kit, 9x5 NBD
64111B2	Lenovo Storage E1012 LFF Disk Expansion Dual SAS IO Module, Rail Kit, 9x5 NBD
64111B3	Lenovo Storage E1024 SFF Disk Expansion Single SAS IO Module, Rail Kit, 9x5 NBD
64111B4	Lenovo Storage E1024 SFF Disk Expansion Dual SAS IO Module, Rail Kit, 9x5 NBD

For details about supported drives and cables for the Lenovo Storage E1012 and E1024, see the Lenovo Press Product Guide:

<http://lenovopress.com/lp0043>

The following table lists the standard models of the 12 Gbps SAS external drive enclosures offered by Lenovo that can be used with the server for storage expansion.

Table 52. D1212 and D1224 standard models

Part number	Description
LFF models	
4587A11*	D1212 LFF Chassis, Dual 3-port ESMs (US English documentation)
4587A1C^	D1212 LFF Chassis, Dual 3-port ESMs (Simplified Chinese documentation)
4587A1J**	D1212 LFF Chassis, Dual 3-port ESMs (Japanese documentation)
SFF models	
4587A31*	D1224 SFF Chassis, Dual 3-port ESMs (US English documentation)
4587A3C^	D1224 SFF Chassis, Dual 3-port ESMs (Simplified Chinese documentation)
4587A3J**	D1224 SFF Chassis, Dual 3-port ESMs (Japanese documentation)

* Available worldwide (except China and Japan)

^ Available only in China

** Available only in Japan

The following table lists the TopSeller models of the 12 Gbps SAS external drive enclosures offered by Lenovo that can be used with the server for storage expansion.

Table 53. D1212 and D1224 TopSeller models

Part number	Description
Brazil and Latin America - LFF models	
4587EAU	D1212 LFF Chassis, Dual 3-port ESMs, 4x 2TB 3.5" HDDs, 4x 0.5m SAS cables
4587EBU	D1212 LFF Chassis, Dual 3-port ESMs, 4x 4TB 3.5" HDDs, 4x 0.5m SAS cables
4587ECU	D1212 LFF Chassis, Dual 3-port ESMs, 4x 6TB 3.5" HDDs, 4x 0.5m SAS cables
4587EDU	D1212 LFF Chassis, Dual 3-port ESMs, 4x 8TB 3.5" HDDs, 4x 0.5m SAS cables
4587EEU	D1212 LFF Chassis, Dual 3-port ESMs, 8x 2TB 3.5" HDDs, 4x 0.5m SAS cables
4587EFU	D1212 LFF Chassis, Dual 3-port ESMs, 8x 4TB 3.5" HDDs, 4x 0.5m SAS cables
4587EGU	D1212 LFF Chassis, Dual 3-port ESMs, 8x 6TB 3.5" HDDs, 4x 0.5m SAS cables
4587EHU	D1212 LFF Chassis, Dual 3-port ESMs, 8x 8TB 3.5" HDDs, 4x 0.5m SAS cables
4587EIU	D1212 LFF Chassis, Dual 3-port ESMs, 12x 2TB 3.5" HDDs, 4x 0.5m SAS cables
4587EJU	D1212 LFF Chassis, Dual 3-port ESMs, 12x 4TB 3.5" HDDs, 4x 0.5m SAS cables
4587EKU	D1212 LFF Chassis, Dual 3-port ESMs, 12x 6TB 3.5" HDDs, 4x 0.5m SAS cables
4587ELU	D1212 LFF Chassis, Dual 3-port ESMs, 12x 8TB 3.5" HDDs, 4x 0.5m SAS cables
Brazil and Latin America - SFF models	
4587E6U	D1224 SFF Chassis, Dual 3-port ESMs, 9x 1.2TB 10K HDDs, 4x 0.5m SAS cables
4587E2U	D1224 SFF Chassis, Dual 3-port ESMs, 9x 1.2TB 10K HDDs, 2x 400GB SSDs, 4x 0.5m SAS cables
4587E4U	D1224 SFF Chassis, Dual 3-port ESMs, 9x 1.2TB 10K HDDs, 4x 400GB SSDs, 4x 0.5m SAS cables
4587E5U	D1224 SFF Chassis, Dual 3-port ESMs, 18x 1.2TB 10K HDDs, 1x 0.5m SAS cable
4587E1U	D1224 SFF Chassis, Dual 3-port ESMs, 18x 1.2TB 10K HDDs, 2x 400GB SSDs, 4x 0.5m SAS cables
4587E3U	D1224 SFF Chassis, Dual 3-port ESMs, 18x 1.2TB 10K HDDs, 4x 400GB SSDs, 4x 0.5m SAS cables

For details about supported drives and cables for the Lenovo Storage D1212 and D1224, see the Lenovo Press Product Guide:

<http://lenovopress.com/lp0512>

The following table lists the standard models of the 12 Gbps SAS external high density drive enclosures offered by Lenovo.

Table 54. D3284 standard models

Description	Part number
Lenovo Storage D3284 4TB x 84 HD Expansion Enclosure	641311F
Lenovo Storage D3284 6TB x 84 HD Expansion Enclosure	641312F
Lenovo Storage D3284 8TB x 84 HD Expansion Enclosure	641313F
Lenovo Storage D3284 10TB x 84 HD Expansion Enclosure	641314F

The following table lists the TopSeller models of the 12 Gbps SAS external high density drive enclosures offered by Lenovo.

Table 55. D3284 TopSeller models

Description	Part number
Lenovo Storage D3284 High Density Expansion Enclosure	6413E5F
Lenovo Storage D3284 4TB x 42 HD Expansion Enclosure	6413E1H
Lenovo Storage D3284 4TB x 84 HD Expansion Enclosure	6413E1F
Lenovo Storage D3284 6TB x 42 HD Expansion Enclosure	6413E2H
Lenovo Storage D3284 6TB x 84 HD Expansion Enclosure	6413E2F
Lenovo Storage D3284 8TB x 42 HD Expansion Enclosure	6413E3H
Lenovo Storage D3284 8TB x 84 HD Expansion Enclosure	6413E3F
Lenovo Storage D3284 10TB x 42 HD Expansion Enclosure	6413E4H
Lenovo Storage D3284 10TB x 84 HD Expansion Enclosure	6413E4F

For details about supported drives, adapters, and cables for the Lenovo Storage D3284, see the Lenovo Press Product Guide:

<http://lenovopress.com/lp0513>

External storage systems

The following table lists the NAS and SAN external storage systems that are offered by Lenovo.

Table 56. External storage systems

Part number	Description
Lenovo ThinkSystem DS Series Storage (SAS host connectivity)	
4599A41*	Lenovo ThinkSystem DS2200 LFF SAS Dual Controller Unit (US English documentation)
4599A4C^	Lenovo ThinkSystem DS2200 LFF SAS Dual Controller Unit (Simplified Chinese documentation)
4599A4J**	Lenovo ThinkSystem DS2200 LFF SAS Dual Controller Unit (Japanese documentation)
4599A21*	Lenovo ThinkSystem DS2200 SFF SAS Dual Controller Unit (US English documentation)
4599A2C^	Lenovo ThinkSystem DS2200 SFF SAS Dual Controller Unit (Simplified Chinese documentation)
4599A2J**	Lenovo ThinkSystem DS2200 SFF SAS Dual Controller Unit (Japanese documentation)

Part number	Description
4617A41*	Lenovo ThinkSystem DS4200 LFF SAS Dual Controller Unit (US English documentation)
4617A4C^	Lenovo ThinkSystem DS4200 LFF SAS Dual Controller Unit (Simplified Chinese documentation)
4617A4J**	Lenovo ThinkSystem DS4200 LFF SAS Dual Controller Unit (Japanese documentation)
4617A21*	Lenovo ThinkSystem DS4200 SFF SAS Dual Controller Unit (US English documentation)
4617A2C^	Lenovo ThinkSystem DS4200 SFF SAS Dual Controller Unit (Simplified Chinese documentation)
4617A2J**	Lenovo ThinkSystem DS4200 SFF SAS Dual Controller Unit (Japanese documentation)
4619A21*	Lenovo ThinkSystem DS6200 SFF SAS Dual Controller Unit (US English documentation)
4619A2C^	Lenovo ThinkSystem DS6200 SFF SAS Dual Controller Unit (Simplified Chinese documentation)
4619A2J**	Lenovo ThinkSystem DS6200 SFF SAS Dual Controller Unit (Japanese documentation)
Lenovo ThinkSystem DS Series Storage (iSCSI or FC host connectivity)	
4599A31*	Lenovo ThinkSystem DS2200 LFF FC/iSCSI Dual Controller Unit (US English documentation)
4599A3C^	Lenovo ThinkSystem DS2200 LFF FC/iSCSI Dual Controller Unit (Simplified Chinese documentation)
4599A3J**	Lenovo ThinkSystem DS2200 LFF FC/iSCSI Dual Controller Unit (Japanese documentation)
4599A11*	Lenovo ThinkSystem DS2200 SFF FC/iSCSI Dual Controller Unit (US English documentation)
4599A1C^	Lenovo ThinkSystem DS2200 SFF FC/iSCSI Dual Controller Unit (Simplified Chinese documentation)
4599A1J**	Lenovo ThinkSystem DS2200 SFF FC/iSCSI Dual Controller Unit (Japanese documentation)
4617A31*	Lenovo ThinkSystem DS4200 LFF FC/iSCSI Dual Controller Unit (US English documentation)
4617A3C^	Lenovo ThinkSystem DS4200 LFF FC/iSCSI Dual Controller Unit (Simplified Chinese documentation)
4617A3J**	Lenovo ThinkSystem DS4200 LFF FC/iSCSI Dual Controller Unit (Japanese documentation)
4617A11*	Lenovo ThinkSystem DS4200 SFF FC/iSCSI Dual Controller Unit (US English documentation)
4617A1C^	Lenovo ThinkSystem DS4200 SFF FC/iSCSI Dual Controller Unit (Simplified Chinese documentation)
4617A1J**	Lenovo ThinkSystem DS4200 SFF FC/iSCSI Dual Controller Unit (Japanese documentation)
4619A11*	Lenovo ThinkSystem DS6200 SFF FC/iSCSI Dual Controller Unit (US English documentation)
4619A1C^	Lenovo ThinkSystem DS6200 SFF FC/iSCSI Dual Controller Unit (Simplified Chinese documentation)
Lenovo Storage S Series (SAS host connectivity)	
64112B1	Lenovo Storage S2200 LFF Chassis SAS Single Controller, Rack Kit, 9x5NBD
64112B2	Lenovo Storage S2200 LFF Chassis SAS Dual Controller, Rack Kit, 9x5NBD
64112B3	Lenovo Storage S2200 SFF Chassis SAS Single Controller, Rack Kit, 9x5NBD
64112B4	Lenovo Storage S2200 SFF Chassis SAS Dual Controller, Rack Kit, 9x5NBD
64113B1	Lenovo Storage S3200 LFF Chassis SAS Single Controller, Rack Kit, 9x5NBD
64113B2	Lenovo Storage S3200 LFF Chassis SAS Dual Controller, Rack Kit, 9x5NBD
64113B3	Lenovo Storage S3200 SFF Chassis SAS Single Controller, Rack Kit, 9x5NBD
64113B4	Lenovo Storage S3200 SFF Chassis SAS Dual Controller, Rack Kit, 9x5NBD
Lenovo Storage S Series (iSCSI or FC host connectivity)	
64114B1	Lenovo Storage S2200 LFF Chassis FC/iSCSI Single Controller, Rack Kit, 9x5NBD
64114B2	Lenovo Storage S2200 LFF Chassis FC/iSCSI Dual Controller, Rack Kit, 9x5NBD
64114B3	Lenovo Storage S2200 SFF Chassis FC/iSCSI Single Controller, Rack Kit, 9x5NBD

Part number	Description
64114B4	Lenovo Storage S2200 SFF Chassis FC/iSCSI Dual Controller, Rack Kit, 9x5NBD
64116B1	Lenovo Storage S3200 LFF Chassis FC/iSCSI Single Controller, Rack Kit, 9x5NBD
64116B2	Lenovo Storage S3200 LFF Chassis FC/iSCSI Dual Controller, Rack Kit, 9x5NBD
64116B3	Lenovo Storage S3200 SFF Chassis FC/iSCSI Single Controller, Rack Kit, 9x5NBD
64116B4	Lenovo Storage S3200 SFF Chassis FC/iSCSI Dual Controller, Rack Kit, 9x5NBD
Lenovo Storage V Series (iSCSI, FC, or FCoE host connectivity)	
6535C1D	Lenovo Storage V3700 V2 LFF Control Enclosure
6535EC1	Lenovo Storage V3700 V2 LFF Control Enclosure (TopSeller)
6535C2D	Lenovo Storage V3700 V2 SFF Control Enclosure
6535EC2	Lenovo Storage V3700 V2 SFF Control Enclosure (TopSeller)
6535C3D	Lenovo Storage V3700 V2 XP LFF Control Enclosure
6535EC3	Lenovo Storage V3700 V2 XP LFF Control Enclosure (TopSeller)
6535C4D	Lenovo Storage V3700 V2 XP SFF Control Enclosure
6535EC4	Lenovo Storage V3700 V2 XP SFF Control Enclosure (TopSeller)
6536C12	Lenovo Storage V5030 LFF Control Enclosure 3Yr S&S
6536C32	Lenovo Storage V5030 LFF Control Enclosure 5Yr S&S
6536C22	Lenovo Storage V5030 SFF Control Enclosure 3Yr S&S
6536C42	Lenovo Storage V5030 SFF Control Enclosure 5Yr S&S
6536B1F	Lenovo Storage V5030F SFF Control Enclosure 3Yr S&S
6536B2F	Lenovo Storage V5030F SFF Control Enclosure 5Yr S&S
IBM Storwize for Lenovo (iSCSI, FC, or FCoE host connectivity)	
6096CU2^	IBM Storwize V3500 3.5-inch Dual Control Storage Controller Unit
6096CU3^	IBM Storwize V3500 2.5-inch Dual Control Storage Controller Unit
6099L2C	IBM Storwize V3700 3.5-inch Storage Controller Unit
6099S2C	IBM Storwize V3700 2.5-inch Storage Controller Unit
6195SC5†	IBM Storwize V7000 2.5-inch Storage Controller Unit, w/3 Yr S&S (Model 524)
6195SCL‡	IBM Storwize V7000 2.5-inch Storage Controller Unit, w/3 Yr S&S (LA) (Model 524)
61951F1†	IBM Storwize V7000 2.5-inch Storage Controller Unit, w/5 Yr S&S (Model 524)
61951FL‡	IBM Storwize V7000 2.5-inch Storage Controller Unit, w/5 Yr S&S (LA) (Model 524)
6195C32†	IBM Storwize V7000 SFF Control Enclosure, 3YR SWMA (Model HC1 [Gen2+])
6195C3L‡	IBM Storwize V7000 SFF Control Enclosure, 3YR SWMA, LA (Model HC1 [Gen2+])
6195C52†	IBM Storwize V7000 SFF Control Enclosure, 5YR SWMA (Model HC1 [Gen2+])
6195C5L‡	IBM Storwize V7000 SFF Control Enclosure, 5YR SWMA, LA (Model HC1 [Gen2+])
Lenovo Storage DX8200 Series (S3 cloud storage)	
5120C1x	Lenovo Storage DX8200C with 14x 4TB 3.5" HDDs and 2x 240GB SSDs
5120C3x	Lenovo Storage DX8200C with 14x 6TB 3.5" HDDs and 2x 480GB SSDs
5120C2x	Lenovo Storage DX8200C with 14x 8TB 3.5" HDDs and 2x 480GB SSDs
Lenovo Storage DX8200 Series (NAS, iSCSI connectivity; optional FC connectivity)	
5135A2x	Lenovo Storage DX8200D Storage Virtualization Entry, 4TB, 3yr SW S&S
5135J2x	Lenovo Storage DX8200D Storage Virtualization Entry, 4TB, 4yr SW S&S
51351Vx	Lenovo Storage DX8200D Storage Virtualization Entry, 4TB, 5yr SW S&S

Part number	Description
5135B2x	Lenovo Storage DX8200D Storage Virtualization Mid, 16TB, 3yr SW S&S
5135L2x	Lenovo Storage DX8200D Storage Virtualization Mid, 16TB, 4yr SW S&S
51352Vx	Lenovo Storage DX8200D Storage Virtualization Mid, 16TB, 5yr SW S&S
5135C2x	Lenovo Storage DX8200D Storage Virtualization High, 64TB, 3yr SW S&S
5135M2x	Lenovo Storage DX8200D Storage Virtualization High, 64TB, 4yr SW S&S
51353Vx	Lenovo Storage DX8200D Storage Virtualization High, 64TB, 5yr SW S&S
5135D2x	Lenovo Storage DX8200D ServerSAN Entry, 8TB, 3yr SW S&S
5135N2x	Lenovo Storage DX8200D ServerSAN Entry, 8TB, 4yr SW S&S
51354Vx	Lenovo Storage DX8200D ServerSAN Entry, 8TB, 5yr SW S&S
5135F2x	Lenovo Storage DX8200D ServerSAN Mid, 16TB, 3yr SW S&S
5135P2x	Lenovo Storage DX8200D ServerSAN Mid, 16TB, 4yr SW S&S
51355Vx	Lenovo Storage DX8200D ServerSAN Mid, 16TB, 5yr SW S&S
5135G2x	Lenovo Storage DX8200D ServerSAN High, 32TB, 3yr SW S&S
5135Q2x	Lenovo Storage DX8200D ServerSAN High, 32TB, 4yr SW S&S
51356Vx	Lenovo Storage DX8200D ServerSAN High, 32TB, 5yr SW S&S
5128C1x	Lenovo Storage DX8200N with 1x N2226 HBA
5128C2x	Lenovo Storage DX8200N with 2x N2226 HBAs

* Available worldwide (except China and Japan).

^ Available only in China.

** Available only in Japan.

† Available worldwide except Latin America.

‡ Available only in Latin America.

For more information, see the list of Product Guides in the following categories:

- Lenovo DS Series, S Series, and V Series storage:
<http://lenovopress.com/storage/san/lenovo?rt=product-guide>
- IBM Storwize for Lenovo storage:
<http://lenovopress.com/storage/san/ibm?rt=product-guide>
- Lenovo Cloud storage:
<http://lenovopress.com/storage/cloud>
- Lenovo NAS storage:
<http://lenovopress.com/storage/nas>

Top-of-rack Ethernet switches

The following table lists the Ethernet LAN switches that are offered by Lenovo.

Table 57. Ethernet LAN switches

Part number	Description
1 Gb Ethernet switches	
7165H1X	Juniper EX2300-C PoE Switch
7165H2X	Juniper EX2300-24p PoE Switch
7159BAX	Lenovo RackSwitch G7028 (Rear to Front)
7159CAX	Lenovo RackSwitch G7052 (Rear to Front)
7159G52	Lenovo RackSwitch G8052 (Rear to Front)
10 Gb Ethernet switches	
7159A1X	Lenovo ThinkSystem NE1032 RackSwitch (Rear to Front)
7159B1X	Lenovo ThinkSystem NE1032T RackSwitch (Rear to Front)
7159C1X	Lenovo ThinkSystem NE1072T RackSwitch (Rear to Front)
7159BR6	Lenovo RackSwitch G8124E (Rear to Front)
7159G64	Lenovo RackSwitch G8264 (Rear to Front)
7159DRX	Lenovo RackSwitch G8264CS (Rear to Front)
7159CRW	Lenovo RackSwitch G8272 (Rear to Front)
7159GR6	Lenovo RackSwitch G8296 (Rear to Front)
40 Gb Ethernet switches	
7159BRX	Lenovo RackSwitch G8332 (Rear to Front)
100 Gb Ethernet switches	
7159D1X	Lenovo ThinkSystem NE10032 RackSwitch (Rear to Front)

For more information, see the list of Product Guides in the following switch categories:

- 1 Gb Ethernet switches: <http://lenovopress.com/networking/tor/1gb?rt=product-guide>
- 10 Gb Ethernet switches: <http://lenovopress.com/networking/tor/10gb?rt=product-guide>
- 40 Gb Ethernet switches: <http://lenovopress.com/networking/tor/40gb?rt=product-guide>
- 100 Gb Ethernet switches: <https://lenovopress.com/networking/tor/100Gb?rt=product-guide>

Fibre Channel SAN switches

The following table lists the Fibre Channel SAN switches that are offered by Lenovo and can be used with this system.

Table 58. Fibre Channel SAN switches

Part number	Description
8 Gb FC	
3873AR3	Lenovo B300, 8 ports activated, 8x 8Gb SWL SFPs, 1 PS, Rail Kit
3873AR4	Lenovo B6505, 12 ports activated, 12x 8Gb SWL SFPs, 1 PS, Rail Kit
3873BR2	Lenovo B6510, 24 ports activated, 24x 8Gb SWL SFPs, 2 PS, Rail Kit
16 Gb FC	
6559D2Y	Lenovo ThinkSystem DB610S, 8 ports activated, 8x 16Gb SWL SFPs, 1 PS, Rail Kit
6559D1Y	Lenovo ThinkSystem DB610S, 24 ports activated, 24x 16Gb SWL SFP, Enterprise SW, 1 PS, Rail Kit
3873AR5	Lenovo B6505, 12 ports activated w/ 16Gb SWL SFPs, 1 PS, Rail Kit
3873BR3	Lenovo B6510, 24 ports activated w/ 16Gb SWL SFPs, 2 PS, Rail Kit
32 Gb FC	
6559D3Y	Lenovo ThinkSystem DB610S, 8 ports activated, 1 PS, Rail Kit
6415G11	Lenovo ThinkSystem DB620S, 24 Ports Activated, 24x 32Gb SWL SFPs, 2 PS, Rail Kit
6415G2A	Lenovo ThinkSystem DB620S, 48 Ports Activated, 48x 32Gb SWL SFPs, 2 PS, Rail Kit
6684B2A	Lenovo ThinkSystem DB400D 32Gb FC Director, up to 192 ports, 8U, Enterprise SW
6682B1A	Lenovo ThinkSystem DB800D 32Gb FC Director, up to 384 ports, 14U, Enterprise SW

For more information, see the list of Product Guides in the Rack SAN Switches category:
<http://lenovopress.com/storage/switches/rack?rt=product-guide>

Uninterruptible power supply units

The following table lists the uninterruptible power supply (UPS) units that are offered by Lenovo.

Table 59. Uninterruptible power supply units

Part number	Description
55941AX	RT1.5kVA 2U Rack or Tower UPS (100-125VAC)
55941KX	RT1.5kVA 2U Rack or Tower UPS (200-240VAC)
55942AX	RT2.2kVA 2U Rack or Tower UPS (100-125VAC)
55942KX	RT2.2kVA 2U Rack or Tower UPS (200-240VAC)
55943AX	RT3kVA 2U Rack or Tower UPS (100-125VAC)
55943KX	RT3kVA 2U Rack or Tower UPS (200-240VAC)
55945KX	RT5kVA 3U Rack or Tower UPS (200-240VAC)
55946KX	RT6kVA 3U Rack or Tower UPS (200-240VAC)
55948KX	RT8kVA 6U Rack or Tower UPS (200-240VAC)
55949KX	RT11kVA 6U Rack or Tower UPS (200-240VAC)
55948PX	RT8kVA 6U 3:1 Phase Rack or Tower UPS (380-415VAC)
55949PX	RT11kVA 6U 3:1 Phase Rack or Tower UPS (380-415VAC)

For more information, see the list of Product Guides in the UPS category:

<https://lenovopress.com/servers/options/ups>

Power distribution units

The following table lists the power distribution units (PDUs) that are offered by Lenovo.

Table 60. Power distribution units

Part number	Description
0U Basic PDUs	
00YJ776	0U 36 C13/6 C19 24A/200-240V 1 Phase PDU with NEMA L6-30P line cord
00YJ777	0U 36 C13/6 C19 32A/200-240V 1 Phase PDU with IEC60309 332P6 line cord
00YJ778	0U 21 C13/12 C19 32A/200-240V/346-415V 3 Phase PDU with IEC60309 532P6 line cord
00YJ779	0U 21 C13/12 C19 48A/200-240V 3 Phase PDU with IEC60309 460P9 line cord
Switched and Monitored PDUs	
00YJ780	0U 20 C13/4 C19 Switched and Monitored 32A/200-240V/1Ph PDU w/ IEC60309 332P6 line cord
00YJ781	0U 20 C13/4 C19 Switched and Monitored 24A/200-240V/1Ph PDU w/ NEMA L6-30P line cord
00YJ782	0U 18 C13/6 C19 Switched / Monitored 32A/200-240V/346-415V/3Ph PDU w/ IEC60309 532P6 cord
00YJ783	0U 12 C13/12 C19 Switched and Monitored 48A/200-240V/3Ph PDU w/ IEC60309 460P9 line cord
46M4002	1U 9 C19/3 C13 Switched and Monitored DPI PDU (without line cord)
46M4003	1U 9 C19/3 C13 Switched and Monitored 60A 3 Phase PDU with IEC 309 3P+Gnd line cord
46M4004	1U 12 C13 Switched and Monitored DPI PDU (without line cord)
46M4005	1U 12 C13 Switched and Monitored 60A 3 Phase PDU with IEC 309 3P+Gnd line cord
Ultra Density Enterprise PDUs (9x IEC 320 C13 + 3x IEC 320 C19 outlets)	
71762NX	Ultra Density Enterprise C19/C13 PDU Module (without line cord)

Part number	Description
71763NU	Ultra Density Enterprise C19/C13 PDU 60A/208V/3ph with IEC 309 3P+Gnd line cord
C13 Enterprise PDUs (12x IEC 320 C13 outlets)	
39M2816	DPI C13 Enterprise PDU+ (without line cord)
39Y8941	DPI Single Phase C13 Enterprise PDU (without line cord)
C19 Enterprise PDUs (6x IEC 320 C19 outlets)	
39Y8948	DPI Single Phase C19 Enterprise PDU (without line cord)
39Y8923	DPI 60A 3 Phase C19 Enterprise PDU with IEC 309 3P+G (208 V) fixed line cord
Front-end PDUs (3x IEC 320 C19 outlets)	
39Y8938	DPI 30amp/125V Front-end PDU with NEMA L5-30P line cord
39Y8939	DPI 30amp/250V Front-end PDU with NEMA L6-30P line cord
39Y8934	DPI 32amp/250V Front-end PDU with IEC 309 2P+Gnd line cord
39Y8940	DPI 60amp/250V Front-end PDU with IEC 309 2P+Gnd line cord
39Y8935	DPI 63amp/250V Front-end PDU with IEC 309 2P+Gnd line cord
NEMA PDUs (6x NEMA 5-15R outlets)	
39Y8905	DPI 100-127V PDU with Fixed NEMA L5-15P line cord
Line cords for PDUs that ship without a line cord	
40K9611	DPI 32a Line Cord (IEC 309 3P+N+G)
40K9612	DPI 32a Line Cord (IEC 309 P+N+G)
40K9613	DPI 63a Cord (IEC 309 P+N+G)
40K9614	DPI 30a Line Cord (NEMA L6-30P)
40K9615	DPI 60a Cord (IEC 309 2P+G)
40K9617	DPI Australian/NZ 3112 Line Cord
40K9618	DPI Korean 8305 Line Cord

For more information, see the Lenovo Press documents in the PDU category:

<https://lenovopress.com/servers/options/pdu>

Rack cabinets

The racks supported by the server are listed in the following table.

Table 61. Rack cabinets

Part number	Description	Maximum supported
Rack cabinets currently available		
9308-4EX	42U Enterprise Expansion Rack	10
9308-4PX	42U Enterprise Rack	10
9360-4PX	42U 1200mm Deep Dynamic Rack	10
9361-4PX	42U 1200mm Deep Static Rack	10
9363-4PX	42U 1100mm Dynamic Rack	10
9363-4EX	42U 1100mm Dynamic Expansion Rack	10
Withdrawn rack cabinets		
9360-4EX	42U 1200mm Deep Dynamic Expansion Rack	10
9361-4EX	42U 1200mm Deep Static Expansion Rack	10
9362-4PX	47U 1200mm Deep Static Rack	11
9362-4EX	47U 1200mm Deep Static Expansion Rack	11
9363-4CX	PureFlex System 42U Rack	10
9363-4DX	PureFlex System 42U Expansion Rack	10

For information about these racks, see the Lenovo Rack Cabinet Reference:
<https://lenovopress.com/lp0658-lenovo-rack-cabinet-reference>

KVM console options

The following table lists the supported KVM consoles, keyboards, and KVM switches.

Table 62. Console keyboards

Part number	Description
Consoles	
17238BX	1U 18.5" Standard Console (without keyboard)
Console keyboards	
00MW310	Lenovo UltraNav Keyboard USB - US Eng
46W6713	Keyboard w/ Int. Pointing Device USB - Arabic 253 RoHS v2
46W6714	Keyboard w/ Int. Pointing Device USB - Belg/UK 120 RoHS v2
46W6715	Keyboard w/ Int. Pointing Device USB - Chinese/US 467 RoHS v2
46W6716	Keyboard w/ Int. Pointing Device USB - Czech 489 RoHS v2
46W6717	Keyboard w/ Int. Pointing Device USB - Danish 159 RoHS v2
46W6718	Keyboard w/ Int. Pointing Device USB - Dutch 143 RoHS v2
46W6719	Keyboard w/ Int. Pointing Device USB - French 189 RoHS v2
46W6720	Keyboard w/ Int. Pointing Device USB - Fr/Canada 445 RoHS v2
46W6721	Keyboard w/ Int. Pointing Device USB - German 129 RoHS v2
46W6722	Keyboard w/ Int. Pointing Device USB - Greek 219 RoHS v2

Part number	Description
46W6723	Keyboard w/ Int. Pointing Device USB - Hebrew 212 RoHS v2
46W6724	Keyboard w/ Int. Pointing Device USB - Hungarian 208 RoHS v2
46W6725	Keyboard w/ Int. Pointing Device USB - Italian 141 RoHS v2
46W6726	Keyboard w/ Int. Pointing Device USB - Japanese 194 RoHS v2
46W6727	Keyboard w/ Int. Pointing Device USB - Korean 413 RoHS v2
46W6728	Keyboard w/ Int. Pointing Device USB - LA Span 171 RoHS v2
46W6729	Keyboard w/ Int. Pointing Device USB - Norwegian 155 RoHS v2
46W6730	Keyboard w/ Int. Pointing Device USB - Polish 214 RoHS v2
46W6731	Keyboard w/ Int. Pointing Device USB - Portugese 163 RoHS v2
46W6732	Keyboard w/ Int. Pointing Device USB - Russian 441 RoHS v2
46W6733	Keyboard w/ Int. Pointing Device USB - Slovak 245 RoHS v2
46W6734	Keyboard w/ Int. Pointing Device USB - Spanish 172 RoHS v2
46W6735	Keyboard w/ Int. Pointing Device USB - Swed/Finn 153 RoHS v2
46W6736	Keyboard w/ Int. Pointing Device USB - Swiss F/G 150 RoHS v2
46W6737	Keyboard w/ Int. Pointing Device USB - Thai 191 RoHS v2
46W6738	Keyboard w/ Int. Pointing Device USB - Turkish 179 RoHS v2
46W6739	Keyboard w/ Int. Pointing Device USB - UK Eng 166 RoHS v2
46W6740	Keyboard w/ Int. Pointing Device USB - US Euro 103P RoHS v2
46W6741	Keyboard w/ Int. Pointing Device USB - Slovenian 234 RoHS v2
Console switches	
1754D2X	Global 4x2x32 Console Manager (GCM32)
1754D1X	Global 2x2x16 Console Manager (GCM16)
1754A2X	Local 2x16 Console Manager (LCM16)
1754A1X	Local 1x8 Console Manager (LCM8)
Console switch cables	
43V6147	Single Cable USB Conversion Option (UCO)
39M2895	USB Conversion Option (4 Pack UCO)
46M5383	Virtual Media Conversion Option Gen2 (VCO2)
46M5382	Serial Conversion Option (SCO)

For more information, see the list of Product Guides in the KVM Switches and Consoles category:
<http://lenovopress.com/servers/options/kvm>

Lenovo Financial Services

Lenovo Financial Services reinforces Lenovo's commitment to deliver pioneering products and services that are recognized for their quality, excellence, and trustworthiness. Lenovo Financial Services offers financing solutions and services that complement your technology solution anywhere in the world.

We are dedicated to delivering a positive finance experience for customers like you who want to maximize your purchase power by obtaining the technology you need today, protect against technology obsolescence, and preserve your capital for other uses.

We work with businesses, non-profit organizations, governments and educational institutions to finance their entire technology solution. We focus on making it easy to do business with us. Our highly experienced team of finance professionals operates in a work culture that emphasizes the importance of providing outstanding customer service. Our systems, processes and flexible policies support our goal of providing customers with a positive experience.

We finance your entire solution. Unlike others, we allow you to bundle everything you need from hardware and software to service contracts, installation costs, training fees, and sales tax. If you decide weeks or months later to add to your solution, we can consolidate everything into a single invoice.

Our Premier Client services provide large accounts with special handling services to ensure these complex transactions are serviced properly. As a premier client, you have a dedicated finance specialist who manages your account through its life, from first invoice through asset return or purchase. This specialist develops an in-depth understanding of your invoice and payment requirements. For you, this dedication provides a high-quality, easy, and positive financing experience.

For your region specific offers please ask your Lenovo sales representative or your technology provider about the use of Lenovo Financial Services. For more information, see the following Lenovo website:

<http://www.lenovofs.com>

Related publications and links

For more information, see these useful resources:

- Lenovo ThinkSystem SR950 product page:
<http://www3.lenovo.com/us/en/p/77XX7HSSR95>
- Interactive 3D Tour of the ThinkSystem SR950:
<http://lenovopress.com/LP0674>
- Lenovo Press walk-through video of the ThinkSystem SR950:
<http://lenovopress.com/LP0702>
- Lenovo ThinkSystem SR950 product publications:
<http://thinksystem.lenovofiles.com/help/index.jsp>
 - Quick Start
 - Rack Installation Guide
 - Setup Guide
 - Hardware Maintenance Manual
 - Messages and Codes Reference
 - Memory Population Reference
- ServerProven hardware compatibility:
<http://www.lenovo.com/us/en/serverproven>

Related product families

Product families related to this document are the following:

- [Mission-Critical Rack Servers](#)
- [4-Socket Rack Servers](#)
- [8-Socket Rack Servers](#)

Notices

Lenovo may not offer the products, services, or features discussed in this document in all countries. Consult your local Lenovo representative for information on the products and services currently available in your area. Any reference to a Lenovo product, program, or service is not intended to state or imply that only that Lenovo product, program, or service may be used. Any functionally equivalent product, program, or service that does not infringe any Lenovo intellectual property right may be used instead. However, it is the user's responsibility to evaluate and verify the operation of any other product, program, or service. Lenovo may have patents or pending patent applications covering subject matter described in this document. The furnishing of this document does not give you any license to these patents. You can send license inquiries, in writing, to:

Lenovo (United States), Inc.
1009 Think Place - Building One
Morrisville, NC 27560
U.S.A.
Attention: Lenovo Director of Licensing

LENOVO PROVIDES THIS PUBLICATION "AS IS" WITHOUT WARRANTY OF ANY KIND, EITHER EXPRESS OR IMPLIED, INCLUDING, BUT NOT LIMITED TO, THE IMPLIED WARRANTIES OF NON-INFRINGEMENT, MERCHANTABILITY OR FITNESS FOR A PARTICULAR PURPOSE. Some jurisdictions do not allow disclaimer of express or implied warranties in certain transactions, therefore, this statement may not apply to you.

This information could include technical inaccuracies or typographical errors. Changes are periodically made to the information herein; these changes will be incorporated in new editions of the publication. Lenovo may make improvements and/or changes in the product(s) and/or the program(s) described in this publication at any time without notice.

The products described in this document are not intended for use in implantation or other life support applications where malfunction may result in injury or death to persons. The information contained in this document does not affect or change Lenovo product specifications or warranties. Nothing in this document shall operate as an express or implied license or indemnity under the intellectual property rights of Lenovo or third parties. All information contained in this document was obtained in specific environments and is presented as an illustration. The result obtained in other operating environments may vary. Lenovo may use or distribute any of the information you supply in any way it believes appropriate without incurring any obligation to you.

Any references in this publication to non-Lenovo Web sites are provided for convenience only and do not in any manner serve as an endorsement of those Web sites. The materials at those Web sites are not part of the materials for this Lenovo product, and use of those Web sites is at your own risk. Any performance data contained herein was determined in a controlled environment. Therefore, the result obtained in other operating environments may vary significantly. Some measurements may have been made on development-level systems and there is no guarantee that these measurements will be the same on generally available systems. Furthermore, some measurements may have been estimated through extrapolation. Actual results may vary. Users of this document should verify the applicable data for their specific environment.

© Copyright Lenovo 2017. All rights reserved.

This document, LP0647, was created or updated on August 22, 2017.

Send us your comments in one of the following ways:

- Use the online Contact us review form found at:
<http://lenovopress.com/LP0647>
- Send your comments in an e-mail to:
comments@lenovopress.com

This document is available online at <http://lenovopress.com/LP0647>.

Trademarks

Lenovo, the Lenovo logo, and For Those Who Do are trademarks or registered trademarks of Lenovo in the United States, other countries, or both. A current list of Lenovo trademarks is available on the Web at <http://www3.lenovo.com/us/en/legal/copytrade/>.

The following terms are trademarks of Lenovo in the United States, other countries, or both:

AnyBay
Bootable Media Creator
Flex System
Lenovo Services
Lenovo XClarity
Lenovo®
RackSwitch
ServerProven®
System x®
ThinkServer®
ThinkSystem
TopSeller
TruDDR4
UltraNav®
UpdateXpress System Packs

The following terms are trademarks of other companies:

Intel and Xeon are trademarks or registered trademarks of Intel Corporation or its subsidiaries in the United States and other countries.

Linux® is a trademark of Linus Torvalds in the United States, other countries, or both.

ActiveX®, Microsoft®, Windows Server®, and Windows® are trademarks of Microsoft Corporation in the United States, other countries, or both.

Other company, product, or service names may be trademarks or service marks of others.