

DETT. C

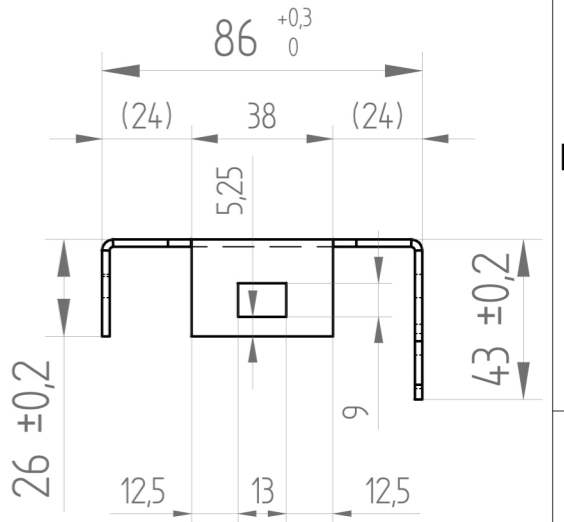

DETT. B

SEZIONE A-A

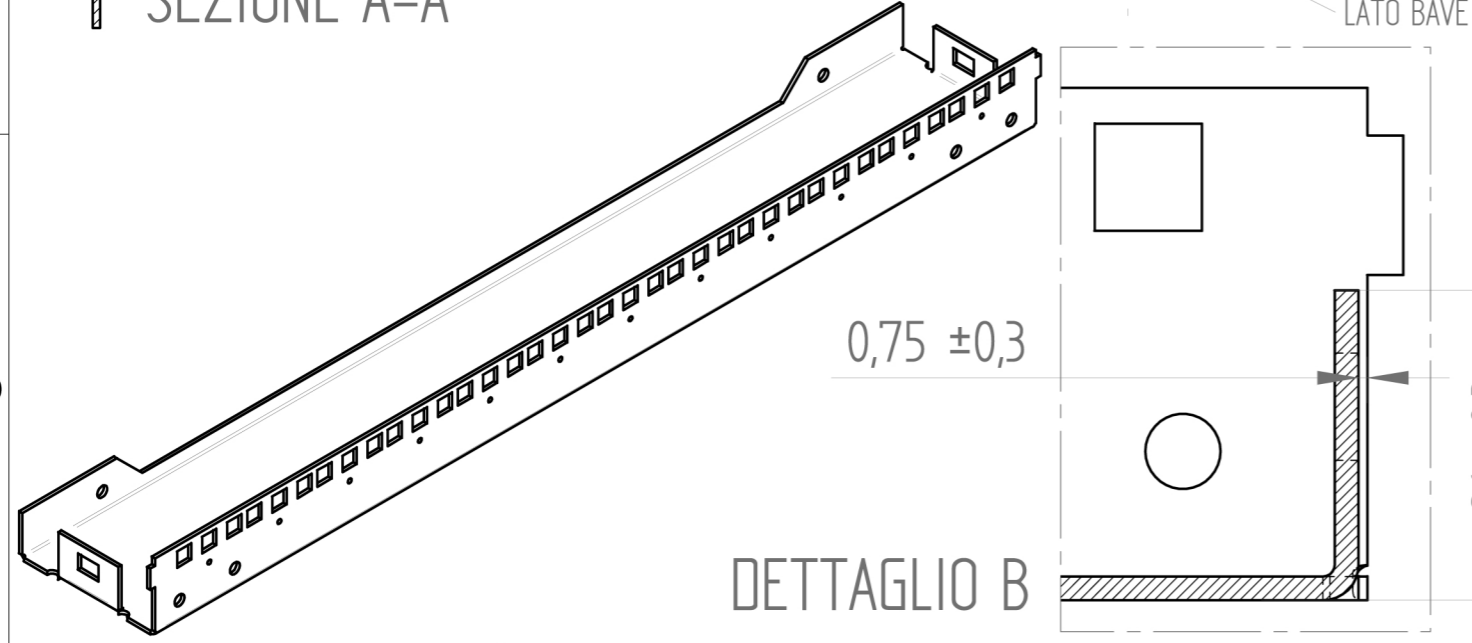

DETTAGLIO B

REV.									
Materiale	DX51D+Z275 N-A UNI/EN 10143 sp.=20/10				Tolleranze secondo: UNI ISO 8015		Tolleranze generali: UNI ISO 2768-m		
Tratt./rivestim.sup.	-				Scala 1:2			Massa (Kg) -	
Descrizione:							MONTANTE ZINCATO		
Rif.							Cod. I-CASE FP-I1210BK		
DIS.N°							Foglio 1/1		