



THINCLIENT-20

NEWSTAR THIN CLIENT MOUNT

Newstar Thin Client Holder (attach between monitor and mount) - Black



SPECIFICATIONS

Color	Black
Height	13,8 cm
Height adjustment	None
Max. weight	10
Min. weight	0
Type	Fixed
VESA maximum	100x100 mm
VESA minimum	50x50 mm
Warranty	5 year
Width	1 - 10 cm
EAN code	8717371443283

The NewStar thin client mount, model THINCLIENT-20, allows you to mount a thin client computer to a monitor mount. A thin client mount creates a neat and clean desk because its stored behind the monitor and doesn't use any valuable desk space. Increase the lifetime of your computer due to reduced intake of dust and dirt. Keep the workplace clean without computers on the desk.

This NewStar thin client mount allows vertical installation of thin client computer between the screen and monitor mount. This product includes VESA50, VESA75 and VESA100 hole pattern to simplify installation with flat screens and flat screen mounts. Hide your cables and keep the workplace nice and tidy.

Easy to adjust in width and depth to fit most thin client PCs. The specifications listed show maximum and minimum width and depth of the mount.

All installation material is included with the product.



**THE BEST SUPPORT
FOR YOUR AV & IT HARDWARE**
T: +31(0)23-5478888 | E: info@newstar.eu | W: www.newstar.eu

THINCLIENT-20

NEWSTAR THIN CLIENT MOUNT

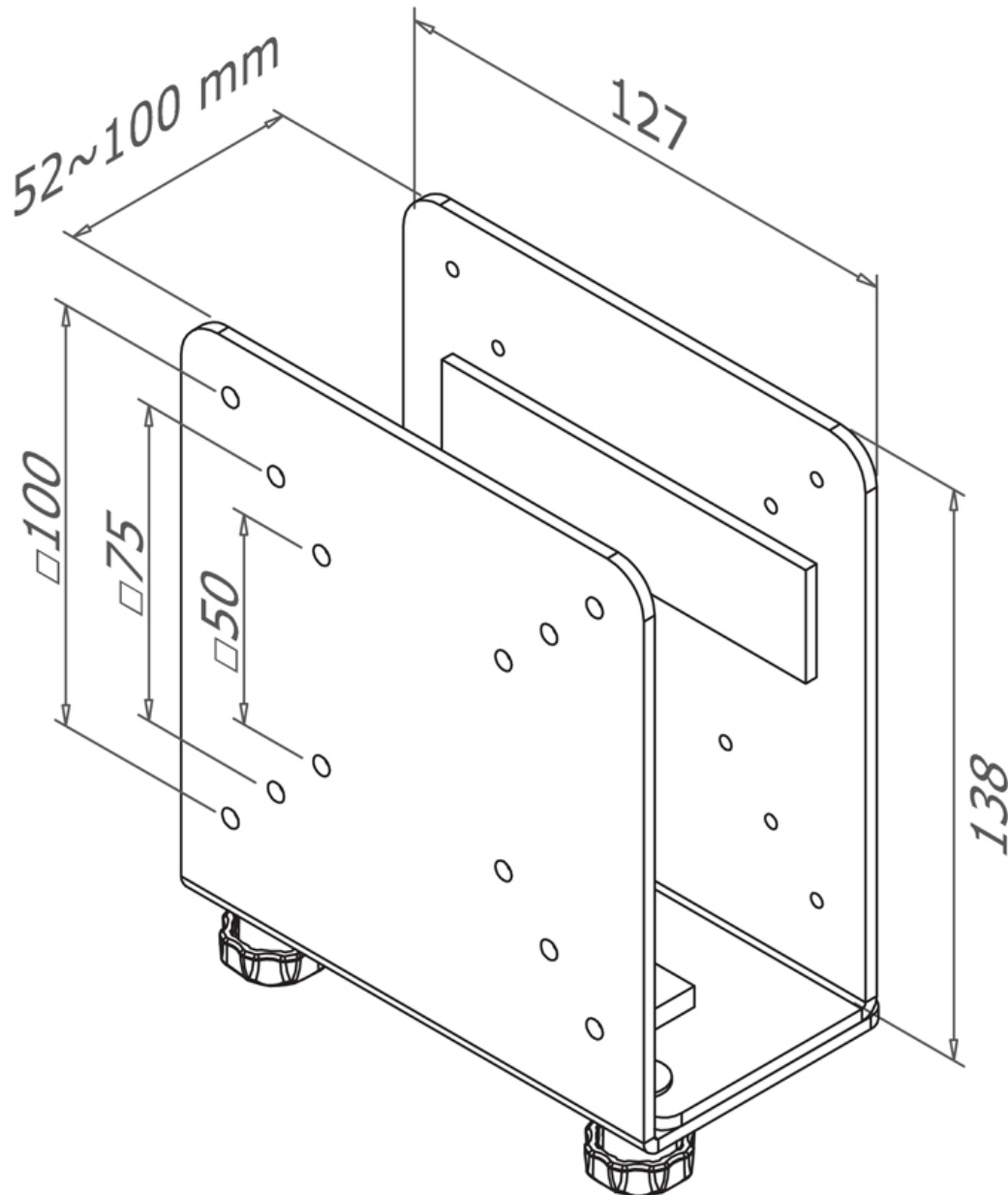

NewStar Products Europe B.V.
Wateringweg 62/B
2031 EJ HAARLEM
THE NETHERLANDS

Phone : +31(0)23-5478888
Fax : +31(0)23-5478889
Email : info@newstar.nl
Website : www.newstar.eu

NewStar cannot be held liable for any inaccuracies and copyrights.
No part of this publication may be reproduced and/or published by print, photocopy, microfilm or in any other way, without prior written permission of NewStar Computer Products Europe BV.