

Technical Datasheet

FTLF8519F2GCL-C

Finisar Coherent® Compatible 2x5 SFF 2.125/1.0625Gbps Transceiver

+3.3V, LC, VCSEL, Multi-Mode, 850nm, 500m, Commercial Temperature

FEATURES

- 2x5 Pin Package, Single-Mode Transceiver
- RoHS Compliant, Lead Free
- FP Laser Diode Transmitter
- 3.3V power supply
- LC duplex optical interface
- Class 1 Laser International Safety Standard IEC 825 Compliant
- Commercial Operating Temperature Range: 0°C to 70°C
- 850nm Oxide VCSEL Transmitter
- CML Differential Inputs and Outputs
- Low Power Dissipation <750mW
- (LV) TTL signal detect
- Distance up to 500m on 50/125µm MMF and 300m 62.5/125µm MMF

APPLICATIONS

- Fiber Channel Switch Infrastructure
- Other Optic Links

DESCRIPTION

ATGBICS FTLF8519F2GCL-C 2x5 form factor transceiver module is high performance and cost effective, the perfect solution for high-speed communication networks.

It supports data rates up to 2.125Gbps. The module is fully compliant with the 2x5 standard package defined by the Small Form Factor Multi-Sourcing Agreement (MSA). It provides the system designer with Telecom, Datacom, and other Fibre Channel applications.

Technical Datasheet

Absolute Maximum Ratings

Parameter	Symbol	Min	Max	Units	Note
Storage Temperature	TST	-40	+85	°C	-
Relative Humidity	RH	0	85	%	-
Supply Voltage	VCC	-0.5	+4.0	V	-

Recommended Operating Environment and Electrical Characteristics:

Parameter	Symbol	Min	Typ	Max	Units	Note
Supply Voltage	VCC	+3.0	-	+3.6	V	-
Supply Current	I _{cc}	-	-	260	mA	-
Operating Case Temperature	TOP	0	-	+70	°C	1
		-40	-	+85		2
Data Rate				5	Gbps	-
Soldering temperature		-	-	260	°C	3
Soldering duration		-	-	10	Sec	3

Notes:

1. Standard level
2. Industrial level
3. Not recommended for wave soldering

Technical Datasheet

Optical Parameters

Optical Characteristics

Transmitter Optical Specifications (Ambient Operating Temperature $T_a = +25 \pm 5^\circ\text{C}$, $V_{CC} = 3.3 \pm 0.2\text{V}$)

Parameter	Symbol	Min	Typ	Max	Units	Notes
Average Launch Power	Po, Avg	-8		0	dBm	
Output Center Wavelength	c	840	850	860	nm	
Output Spectrum Width	σ			0.45	nm	RMS(σ)
Laser Off Power	Poff			-30	dBm	
Extinction Ratio	ER	8.2			dB	
Relative Intensity Noise	RIN			-128	dB/Hz	12dB reflectio n
Transmitter Disperion Penalty	TDP			3.9	dB	
Optical Return Loss Tolerance				12	dB	

Receiver Optical Specifications (Ambient Operating Temperature $T_a = +25 \pm 5^\circ\text{C}$, $V_{CC} = 3.3 \pm 0.2\text{V}$)

Parameter	Symbol	Min	Typ	Max	Units	Notes
Input Center Wavelength	c	840	850	860	nm	
Receiver Sensitivity	Sen1			-16	dBm	
Receiver Overload	PMAX	-1			dBm	
LOS -- Deasserted	LOSD			-16	dBm	Transition: low to high
LOS -- Asserted	LOSA	-30			dBm	Transition: high to low
Los Hysteresis	LOSH	0.5	-	-	dB	
Receiver Reflectance				-12	dB	

Technical Datasheet

Electrical Parameters

Transceiver Electrical Characteristics (Ambient Operating Temperature $T_a = +25 \pm 5^\circ\text{C}$, $V_{CC} = 3.3 \pm 0.2\text{V}$)

Parameter	Symbol	Min	Typ	Max	Units	Notes
High-Speed Signal (CML) Interface Specification						
Input Data Rate			-	5	Gb/s	
Differential Input Impedance	R _{in}	80	100	120	Ω	Internally AC coupled
Single Ended Output Voltage Tolerance		-0.3		4	V	
Common mode voltage tolerance		15			mV	
Tx Input Diff Voltage	V _I	90		350	mV	
Tx Fault	V _{oL}	-0.3		0.4	V	At 0.7mA
Output Data Rate			-	5	Gb/s	
Differential Output Impedance	R _{out}		100		Ω	
Single Ended Output Voltage Tolerance		-0.3		4	V	
Rx Output Diff Voltage	V _o	150		425	mV	
Rx Output Rise and Fall Time	T _r /T _f	30			ps	20% to 80%
Low-Speed Signal (LVTTTL) Interface Specification						
Input High Voltage		2.0		V _{cc} +0.3	V	
Input Low Voltage		GN D		0.8	V	
Output High Voltage		2.4		V _{cc}	V	
Output Low Voltage		GN D		0.5	V	

Technical Datasheet

Pin Assignment

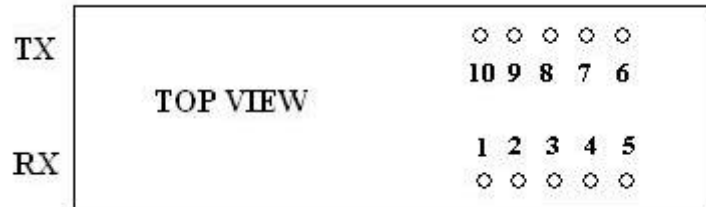

Pin Function Definitions

Pin #	Pin Name	Description	Note
1	VEER	Receiver Ground	-
2	VCCR	Receiver Power Supply	-
3	SD	Signal Detect. (LV)PECL or (LV)TTL output	1
4	RD-	Inv. Received Data Out	-
5	RD+	Received Data Out	-
6	VCCT	Transmitter Power Supply	-
7	VEET	Transmitter Ground	-
8	TDIS	Transmitter Disable	2
9	TD+	Transmit Data In	-
10	TD-	Inv. Transmit Data In	-

Notes:

1: (LV)PECL-Normal optical input levels to the receiver result in logic "1" output, pull-down 130Ω or 270Ω resistor, (LV)TTL-Normal optical input levels to the receiver result in logic "0" output, pull-up 10kΩ resistor.

2: This is an input that is used to shut down the transmitter optical output. Transmitter on in logic "0".

Technical Datasheet

Recommended Circuit

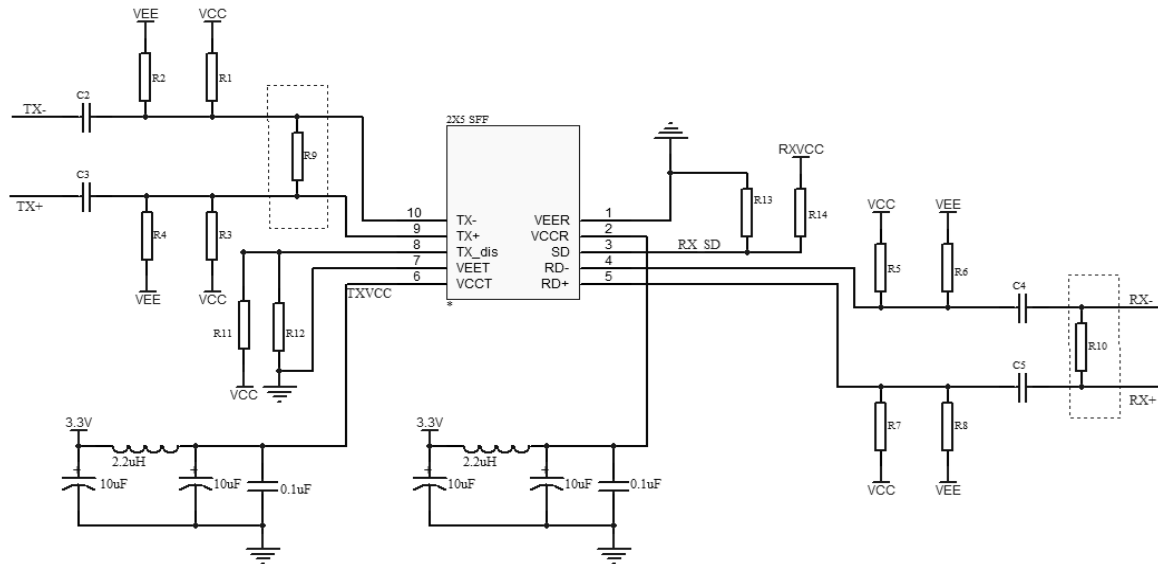

$R1=R3=R5=R7=130\Omega$, $R2=R4=R6=R8=82\Omega$, $C2=C3=C4=C5=104p$, $R5=R10=100\Omega=NC$,
 $R11=R12=10K$,

$SD=LVPECL:R14=10K=NC$, $R13=130\Omega, SD=LVTTTL:R14=10K$, $R12=130\Omega=NC$.

Technical Datasheet

Mechanical Dimensions (units: mm)

