

Rolling TV Cart for 55" to 85" Displays, Wide Legs, Locking Casters

MODEL NUMBER: DMCS5585WL

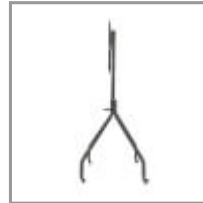
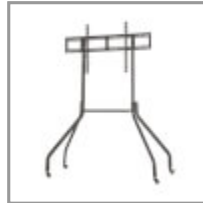
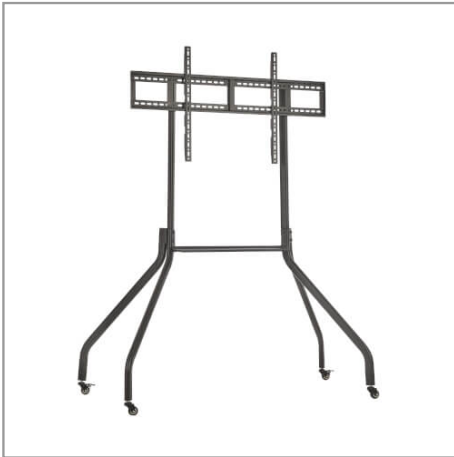

Height-adjustable mobile cart with wide legs lets you smoothly roll your 55 to 85 in. display from one room to another.

Features

Move Your Monitor, TV or Interactive Whiteboard Wherever Your Audience Is

This rugged rolling TV stand combines a height-adjustable display mount with the convenience of a mobile cart. Mount your television, digital whiteboard or touchscreen monitor to the all-metal unit in landscape mode, and then roll it safely and smoothly from room to room.

Designed for Heavy-Duty Use

The durable DMCS5585WL is constructed from heavy-duty steel and aluminum with extra wide legs that provide stability whether in motion or at rest. It helps you deliver your message in corporate settings, open-plan offices, modern waiting rooms and medical facilities.

Comes Ready to Roll Wherever You Need to Go

Three-inch swivel casters allow you to roll the DMCS5585WL into any office, conference room, huddle space or classroom best suited for cost-efficient resource sharing. Ease of movement allows collaborative workflow to happen in any location and maximizes usage to increase engagement, creativity and productivity. The casters lock into place to keep the stand securely in position while at rest.

Raise and Lower the Screen to Find the Most Comfortable Viewing Angle

The height-adjustable TV floor stand fits most displays, whiteboards and monitors from 55 to 85 inches. Its durable frame withstands the stress of repeated adjustments and supports up to 198 pounds. You can raise or lower the height of the display from 71.3 to 81.5 inches above the floor.

VESA-Compliant Mounting Ensures Display Compatibility

VESA (Video Electronics Standards Association) promotes uniformity in the video electronics industry by developing standards for TVs and monitors. For hassle-free display compatibility, this mount supports the following VESA mounting hole patterns: 100 x 100, 200 x 100, 200 x 200, 300 x 100, 300 x 200, 300 x 300, 400 x 100, 400 x 200, 400 x 300, 400 x 400, 600 x 400, 1000 x 400 and 1000 x 600.

Highlights

- Ideal for rolling your TV or whiteboard into offices, classrooms and conference rooms
- Durable aluminum/steel frame blends into any room décor and supports up to 198 lb.
- Height adjusts from 71 to 81 in. to help you find your audience's ideal viewing angle
- Locking 3 in. swivel casters enable smooth rolling and lock to secure the cart at rest
- Extra wide legs allow more stability and safety in motion and at rest

System Requirements

- Television, monitor, digital whiteboard or interactive display from 55 to 85 in. and up to 198 lb.
- Supports the following VESA patterns: 100 x 100, 200 x 100, 200 x 200, 300 x 100, 300 x 200, 300 x 300, 400 x 100, 400 x 200, 400 x 300, 400 x 400, 600 x 400, 1000 x 400 and 1000 x 600

Package Includes

- DMCS5585WL Professional Rolling TV Cart
- Owner's manual

Specifications

OVERVIEW



Powering Business Worldwide



UPC Code	037332275516
Device Compatibility	Monitor/HDTV
PHYSICAL	
Color	Black
Material of Construction	Aluminum, Steel
VESA Pattern (mm)	100x100; 200x100; 200x200; 300x200; 300x300; 400x200; 400x300; 400x400; 600x400; 1000x400; 1000x600; 300x100; 400x100
Motion	Fixed
Mounting Location	Floor
Minimum Screen Size (in.)	55
Minimum Screen Size (cm)	139.7
Maximum Screen Size (in.)	85
Maximum Screen Size (cm)	215.9
Maximum Weight Capacity (lbs.)	198
Maximum Weight Capacity (kg)	90
Number of Displays	1
Shipping Dimensions (hwd / in.)	47.40 x 3.74 x 13.40
Shipping Dimensions (hwd / cm)	120.40 x 9.50 x 34.04
Shipping Weight (lbs.)	45.20
Shipping Weight (kg)	20.50
Unit Dimensions (hwd / in.)	81.300 x 58.000 x 28.350
Unit Weight (lbs.)	43
Unit Weight (kg)	19.50
Assembly Required	Yes
FEATURES & SPECIFICATIONS	
Antimicrobial	No
Cord Management	No
Tools Necessary	Yes
Security Lock	No
Built-in Cable Management	No
Pre-Installed Casters	Yes
STANDARDS & COMPLIANCE	
Product Compliance	RoHS
WARRANTY & SUPPORT	



Powering Business Worldwide



Product Warranty Period (Worldwide)	5-year limited warranty
--	-------------------------

1000 Eaton Boulevard
Cleveland, OH 44122
United States
<https://tripplite.eaton.com>

© 2024 Eaton. All Rights Reserved.
Eaton is a registered trademark. All other trademarks
are the property of their respective owners.