

# Technical Datasheet

## QDD4-400GB-ER8-AR

### Arista Compatible 400GBase-ER8 QSFP-DD Optical Transceiver

Hot Pluggable, 1270nm to 1330nm,+3.3V, LC, SMF 40km

#### FEATURES

- QSFP-DD MSA compliant
- Compliant to IEEE 802.3bs 400GBASE-ER8
- Digital diagnostic monitoring support
- Hot pluggable 76 pin electrical interface
- 8 LAN-WDM lanes MUX/DEMUX design
- 53.125Gbit/s PAM4 Channel Electrical Serial Interface (400GAUI-8)
- Maximum power consumption 15.4W
- LC duplex connector
- Supports 425Gb/s bit rate
- Up to 40km transmission on single mode fiber
- Operating case temperature: 0°C to 70°C
- Single 3.3V power supply
- RoHS 2.0 compliant

#### APPLICATIONS

- 400GBASE-ER8 Ethernet
- Telecom networking
- Data Center Interconnect

#### DESCRIPTION

ATGBICS QDD4-400GB-ER8-AR-C transceiver module is designed for 40km optical communication applications, and it is compliant with IEEE 802.3bs for 400GE Ethernet. This module contains 8-lane optical transmitter, 8-lane optical receiver and module management block including 2 wire serial interfaces. The optical signals are multiplexed to a single-mode fiber through an industry standard LC connector. A block diagram is shown in Figure 1.

# Technical Datasheet

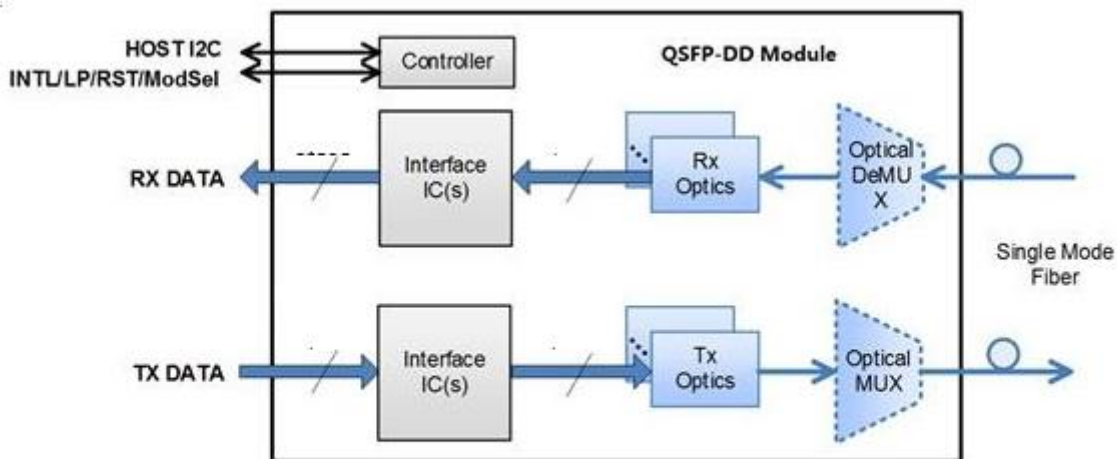

Figure 1. Transceiver Block Diagram

# Technical Datasheet

## PIN DESCRIPTIONS

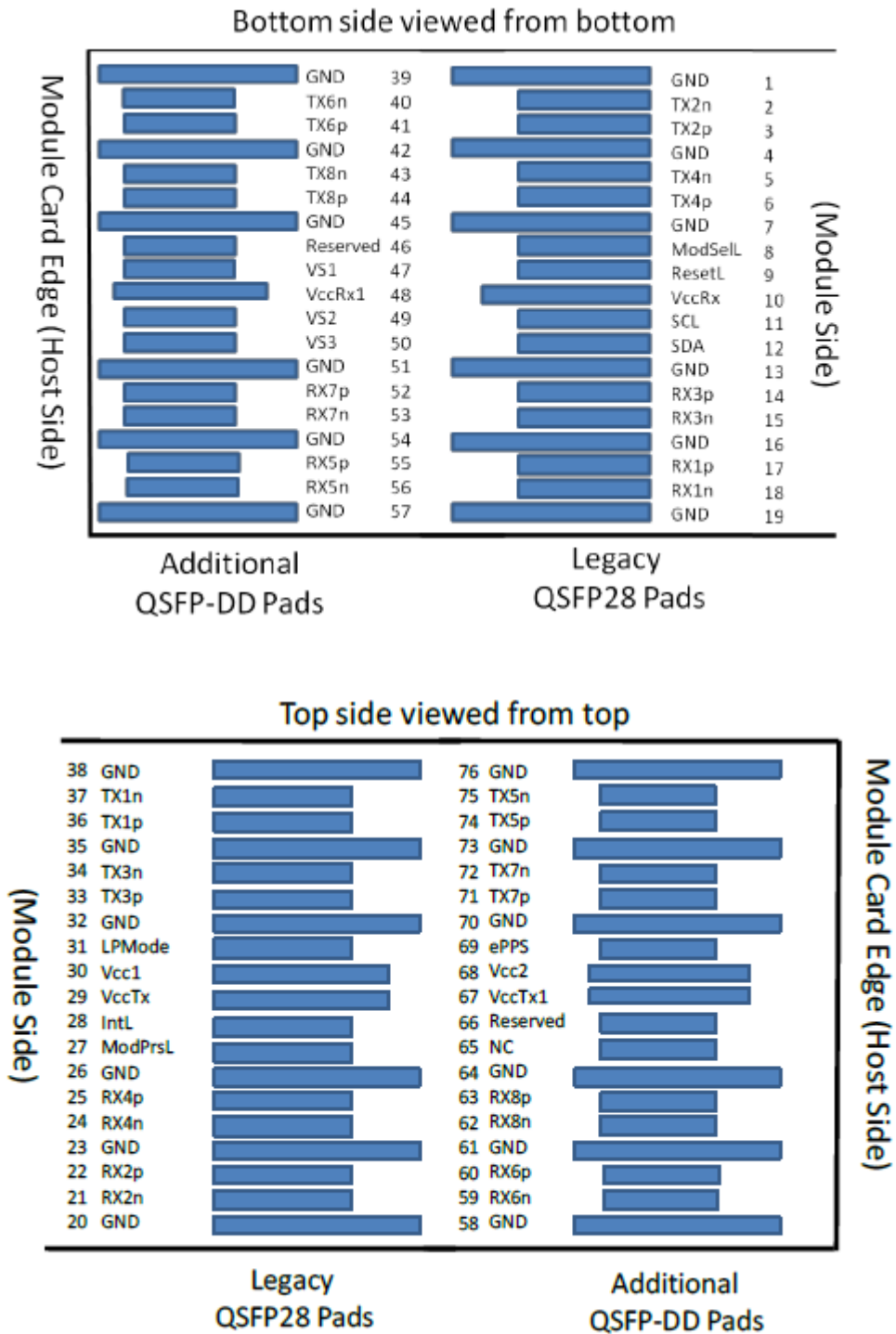

Figure 2. MSA compliant Connector

# Technical Datasheet

Pin	Symbol	Description	Notes
1	GND	Ground	1
2	Tx2n	Transmitter Inverted Data Input	
3	Tx2p	Transmitter Non-Inverted Data Input	
4	GND	Ground	1
5	Tx4n	Transmitter Inverted Data Input	
6	Tx4p	Transmitter Non-Inverted Data Input	
7	GND	Ground	1
8	ModSelL	Module Select	
9	ResetL	Module Reset	
10	VccRx	+3.3V Power Supply Receiver	2
11	SCL	2-wire serial interface clock	
12	SDA	2-wire serial interface data	
13	GND	Ground	1
14	Rx3p	Receiver Non-Inverted Data Output	
15	Rx3n	Receiver Inverted Data Output	
16	GND	Ground	1
17	Rx1p	Receiver Non-Inverted Data Output	
18	Rx1n	Receiver Inverted Data Output	
19	GND	Ground	1
20	GND	Ground	1
21	Rx2n	Receiver Inverted Data Output	
22	Rx2p	Receiver Non-Inverted Data Output	
23	GND	Ground	1
24	Rx4n	Receiver Inverted Data Output	
25	Rx4p	Receiver Non-Inverted Data Output	
26	GND	Ground	1
27	ModPrsL	Module Present	
28	IntL	Interrupt	
29	VccTx	+3.3V Power supply transmitter	2
30	Vcc1	+3.3V Power supply	2
31	LPMode	Low Power mode	
32	GND	Ground	1
33	Tx3p	Transmitter Non-Inverted Data Input	
34	Tx3n	Transmitter Inverted Data Input	
35	GND	Ground	1
36	Tx1p	Transmitter Non-Inverted Data Input	
37	Tx1n	Transmitter Inverted Data Input	
38	GND	Ground	1
39	GND	Ground	1
40	Tx6n	Transmitter Inverted Data Input	
41	Tx6p	Transmitter Non-Inverted Data Input	
42	GND	Ground	1

# Technical Datasheet

## Notes

1. QSFP-DD uses common ground (GND) for all signals and supply (power). All are common within the QSFP-DD module and all module voltages are referenced to this potential unless otherwise noted. Connect these directly to the host board signal-common ground plane.
2. VccRx, VccRx1, Vcc1, Vcc2, VccTx and VccTx1 shall be applied concurrently. Requirements defined for the host side of the Host Card Edge Connector. VccRx, VccRx1, Vcc1, Vcc2, VccTx and VccTx1 may be internally connected within the module in any combination. The connector Vcc pins are each rated for a maximum current of 1000 mA.
3. All Vendor Specific, Reserved and No Connect pins may be terminated with 50ohms to ground on the host. Pad 65 (No Connect) shall be left unconnected within the module. Vendor specific and reserved pads shall have an impedance to GND that is greater than 10K ohms and less than 100pF.

## ABSOLUTE MAXIMUM RATINGS

The operation in excess of any absolute maximum ratings might cause permanent damage to this module

Parameter	Symbol	Min	Typ	Max	Unit	Notes
Maximum Supply Voltage	Vcc	-0.5	3.3	3.6	V	
Storage Temperature	Ts	-40		85	°C	
Relative Humidity	RH	10		85	%	1
Damage Threshold, each lane	THd	-3.4			dBm	

## Notes

1. Non-condensing

## OPERATING ENVIRONMENTS

Electrical and optical characteristics below are defined under this operating environment, unless otherwise specified.

Parameter	Symbol	Min	Typical	Max	Unit
Supply Voltage	Vcc	3.135	3.3	3.465	V
Case Temperature	Top	0		70	°C
Link Distance with G.652				40	km

# Technical Datasheet

## ELECTRICAL CHARACTERISTICS

Parameter	Symbol	Min	Typ	Max	Unit	Notes
Power dissipation				15.4	W	
Supply Current	I <sub>cc</sub>			4.912	A	Steady state
<b>400GAUI-8 Electrical Characteristics</b>						
<b>Transmitter</b>						
Signaling Rate, each lane			26.5625		GBd	PAM4
Differential Voltage pk-pk	V <sub>in</sub> , pp			880	mV	
Common Mode Voltage	V <sub>cm</sub>	-0.3		2.8	V	
Common Mode Noise	RMS			17.5	mV	
Differential Termination Resistance Mismatch				10	%	
Transition time	Trise/Tfall	12			ps	20%~80%
Eye Width at 10 <sup>-6</sup> probability	EW6	0.2			UI	
Eye Height at at 10 <sup>-6</sup> probability	EH6	32			mV	
Eye Linearity		0.85				
<b>Receiver</b>						
Signaling Rate, each lane			26.5625		GBd	PAM4
Differential Voltage pk-pk	V <sub>out</sub> , pp			900	mV	
Transition time	Trise/Tfall	9.5			ps	20%~80%

# Technical Datasheet

Near-end eye width at $10^{-6}$ probability	EW6	0.265			UI	
Near-end eye height at $10^{-6}$ probability	EH6	70			mV	
Far-end eye width at $10^{-6}$ probability	EW6	0.2			UI	
Far-end eye height at $10^{-6}$ probability	EH6	30			mV	
Near-end Eye Linearity		0.85				

Notes

1. 400GAUI-8 Electrical Characteristics refers to CEI-56G-VSR-PAM4 of OIF-CEI-04.0

# Technical Datasheet

## OPTICAL CHARACTERISTICS

**400GBASE-ER8 Operation** (EOL, TOP = 0 to +70°C, VCC = 3.135 to 3.465 Volts)

Parameters	min	type	max	Unit	Note
<b>Transmitter</b>					
Signaling Speed per Lane	26.5625 ± 100 ppm			GBd	
Transmit wavelengths	1272.55	1273.54	1274.54	nm	
	1276.89	1277.89	1278.89		
	1281.25	1282.26	1283.27		
	1285.65	1286.66	1287.68		
	1294.53	1295.56	1296.		
	1299.02	1300.05	1301.		
	1303.54	1304.58	1305.		
	1308.09	1309.14	1310.		
			14.6		
	-0.6		5.6		
	2.4		6.4		
	6				
	30				
			3.4		
			-30		
			-132		
		15			
		-26			
<b>Receiver</b>					
Signaling Speed per Lane	26.5625 ± 100 ppm			GBd	
	1272.55	1273.54	1274.54		
	1276.89	1277.89	1278.89		
	1281.25	1282.26	1283.27		
	1285.65	1286.66	1287.68		
	1294.53	1295.56	1296.59		



# Technical Datasheet

	1299.02	1300.05	1301.09		
	1303.54	1304.58	1305.63		
Receive wavelengths	1308.09	1309.14	1310.19	nm	
Average receiver power, each lane	-18.6		-4.4	dBm	
Receiver power, each lane (OMA)			-3.6	dBm	
Difference in receive power between any two			5.8	dB	
Damage threshold, each lane	-3.4			dBm	
Receiver sensitivity (OMA), each lane			RS	dBm	1
LOS Assert	-30			dBm	
LOS Deassert			-20.6	dBm	
LOS Hysteresis	0.5			dB	
Receiver reflectance			-26	dB	

1, RS=max(-16.1, SECQ-17.5) (dBm). For the requirement of receiver sensitivity, the value of BER is 2e-4 before FEC.

## DIAGNOSTIC MONITORING FUNCTIONS

QDD4-400GB-ER8-AR support the I2C-based Diagnostic Monitoring Interface (DMI) defined in document QSFP-DD Common Management Interface Specification Rev 4.0. The host can access real-time performance of transmitter and receiver optical power, temperature, supply voltage and bias current

Performance Item	Related Bytes	Monitor Error	Notes
Module temperature	14 to 15 at Page low	+/-3°C	1, 2
Module voltage	16 to 17 at Page low	< 5%	2
LD Bias current	170 to 185 at Page	< 10%	2
Transmitter optical power	154 to 169 at Page	< 3dB	2
Receiver optical power	186 to 201 at Page	< 3dB	2

1. Actual temperature test point is fixed on module case around Laser Array.
2. Full operating temperature range

# Technical Datasheet

## ALARM AND WARNING THRESHOLDS

ATGBICS QDD4-400GB-ER8-AR-C supports alarm function, indicating the values of the preceding basic performance are lower or higher than the thresholds

Performance Item	Alarm Threshold Bytes	Low threshold	High threshold
Temp Alarm	128 to 131 at Page 02	-10 °C	80 °C
Temp Warning	132 to 135 at Page 02	0 °C	70 °C
Voltage Alarm	136 to 139 at Page 02	2.97 V	3.63 V
Voltage Warning	140 to 143 at Page 02	3.135 V	3.465 V
TX Power Alarm	176 to 179 at Page 02	-3.6 dBm	8.16 dBm
TX Power Warning	180 to 183 at Page 02	-0.6 dBm	5.6 dBm
RX Power Alarm	192 to 195 at Page 02	-21.6 dBm	-1.4 dBm
RX Power Warning	196 to 199 at Page 02	-18.6 dBm	-4.4 dBm

# Technical Datasheet

## MECHANICAL SPECIFICATIONS

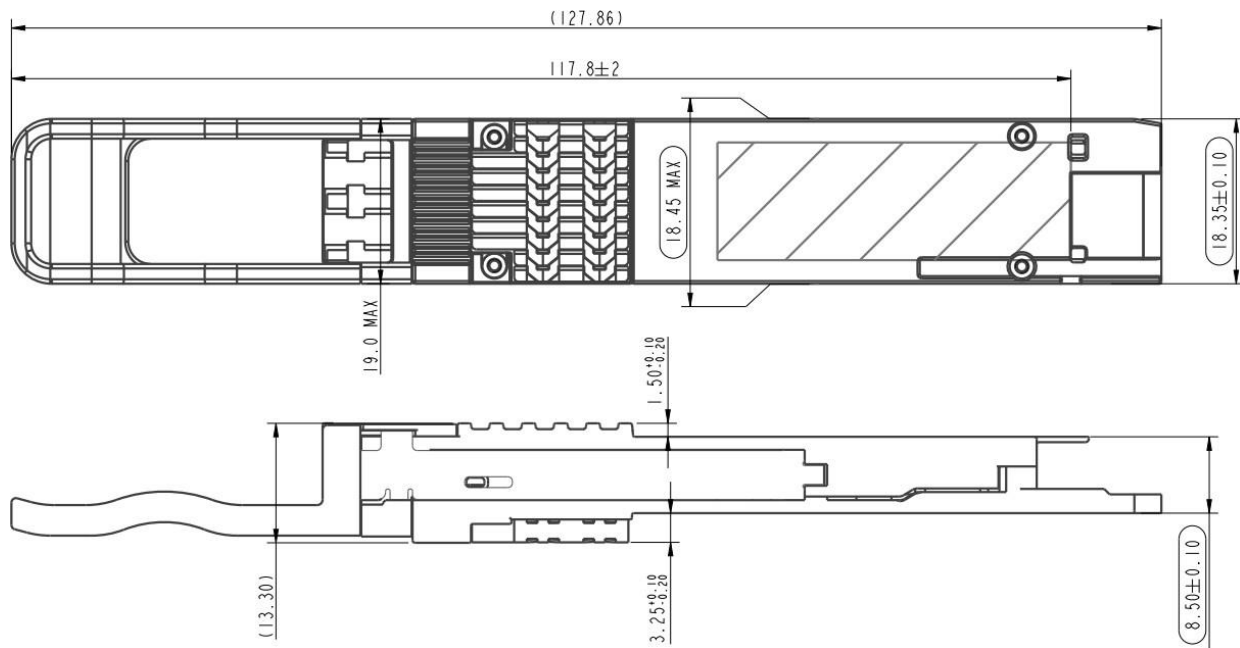

**Figure 3. QDD4-400GB-ER8-AR Mechanical Dimensions**

# Technical Datasheet

## REGULATORY COMPLIANCE

Feature	Agency	Standard	Performance
Safety	NRTL	UL 62368-1  CAN/CSA C22.2 No. 62368-1	NRTL recognized component for US  and CAN
	TUV	EN 62368-1  IEC 60825-1:2014  EN 60825-1:2014  IEC 60825-  2:2004+A1:2006+A2:2010  EN 60825-  2:2004+A1:2006+A2:2010	TUV certificate
	FDA	U.S. 21 CFR 1040.10	FDA/CDRH certified with accession  number according to Laser Notice 56
Electromagnetic Compatibility	Radiated emissions	EMC Directive 2014/30/EU  EN 55032  CISPR 32  FCC rules 47 CFR Part 15  ICES-003  AS/NZS CISPR 32	Class B digital device with a mini-  mum -6dB margin to the limit when  tested with a metal enclosure. Final  margin may vary depending on sys-  tem application, good system EMI  design practice, ie: suitable metal en-

# Technical Datasheet

			closure and well-bonding, is required  to achieve Class B margins at the system level. Tested frequency range: 30 MHz to 40 GHz or 5th harmonic (5 times the highest frequency), whichever is less.
	ESD	EMC Directive 2014/30/EU  EN 55035  CISPR 35  IEC/EN 61000-4-2	Withstands discharges of $\pm 8$ k V contact, $\pm 15$ k V air.
	Radiated immunity	EMC Directive 2014/30/EU EN 55035  CISPR 35  IEC/EN 61000-4-3	Field strength of 10 V/m from 80 MHz to 6 GHz.
Restriction of Hazardous Substances	RoHS	EU Directive 2011/65/EU  (EU) 2015/863	

# Technical Datasheet

## ESD

This transceiver is specified as ESD threshold 1kV for high speed data pins and 2kV for all other electrical input pins, tested per MIL-STD-883, Method 3015.4 /JESD22-A114-A (HBM). However, normal ESD precautions are still required during the handling of this module. This transceiver is shipped in ESD protective packaging. It should be removed from the packaging and handled only in an ESD protected environment

## Laser Safety

This is a Class 1 Laser Product according to EN 60825-1:2014. This product complies with 21 CFR 1040.10 and 1040.11 except for deviations pursuant to Laser Notice No. 50, dated (June 24, 2007).

Caution: Use of controls or adjustments or performance of procedures other than those specified herein may result in hazardous radiation exposure.