

Cabling instructions for –(48–60) V DC power supply

Notes, Cautions, and Warnings

- ① **NOTE:** A NOTE indicates important information that helps you make better use of your product.
- △ **CAUTION:** A CAUTION indicates either potential damage to hardware or loss of data and tells you how to avoid the problem.
- △ **WARNING:** A WARNING indicates a potential for property damage, personal injury, or death.

This document describes the requirements and power and safety ground cable wiring instructions for systems equipped with a –(48–60) V DC power supply.

△ **CAUTION:**

- **This installation should only be done by a qualified licensed electrician.** Do not attempt to connect DC power or install safety grounds yourself. All electrical wiring must comply with applicable local or national codes and practices.
- After the electrician completes the installation, the power supply input plug can be plugged and unplugged like a normal AC power cable. The DC power must be turned off before attempting to plug and unplug the input plug.
- You should only perform troubleshooting and simple repairs as authorized in your product documentation, or as directed by the online or telephone service and support team. Damage due to servicing that is not authorized by Dell is not covered by your warranty. Read and follow the safety instructions that are shipped with your product.
- Wire the unit with copper only (unless otherwise specified), of the size (AWG) as defined in the subsequent sections of this document.
- Protect the –(48–60) V (1 wire) with a branch circuit overcurrent protection rated 40 A with 8 AWG and 32 A with 10 AWG for DC with a high interrupt current rating.
- Connect the equipment to a –(48–60) V DC SELV supply source that is electrically isolated from the AC source.
- Ensure that the –(48–60) V DC source is efficiently secured to earth (ground).
- A readily accessible disconnect device that is suitably approved and rated shall be incorporated in the field wiring.

Input requirements:

Supply voltage: -(48-60) V DC

Current consumption:

- 800 W – 19.1 A maximum;
- 1100 W – 27 A maximum;
- 1400 W - 33.5 A maximum

Kit contents: Plug with crimp terminals (1) – Dell Part # RN5T2

Required Tools:

- Philips P2 screwdriver
- Nut driver – For 800 W and 1100 W use M4, for 1400 W use M5
- Stripping Pliers – capable of removing insulation from 8 AWG and 10 AWG stranded insulated copper wire
- Crimping tool (YQK-70.DELIXI) or equivalent crimping tool capable of crimping a terminal to a 8 AWG wire and 10 AWG wire
- Heat Gun or suitable tool to shrink Heat Shrink tubing

Required Materials:

- Heat Shrink tubing 3/8 inches (Shrink Ratio 2 to 1), 3 inches (76.2 mm) total minimum length 1.5 inch (38.1 mm) per terminal
- Wire (UL1015, 2m maximum),
 - 10 AWG Alpha wire part #3018, or equivalent 105/30 stranded wire
 - 8 AWG Alpha wire part #788133, or equivalent 133/29 stranded wire

PSU Capacity	Black Wire (-(48-60) V DC)	Red Wire (V DC return)	Green / Yellow Wire (safety ground)
800 W	10 AWG	10 AWG	10 AWG
1100 W	10 AWG	10 AWG	10 AWG
1400 W	8 AWG	8 AWG	8 AWG

- A Ring-tongue terminal of M4 Stud Size for 800 W and 1100 W; M5 Stud Size for 1400 W. Either a Straight or Right Angle ring-tongue terminal can be used. The Installation Electrician should decide which is best for the safety ground installation.

1. Assembling and connecting the safety ground wire

(i) NOTE: This product is intended to be used in CBN (Common Bonding Network) applications.

1. Strip the insulation from the end of the green/yellow wire (size as defined in table above), exposing approximately 4.5mm (0.175 inches) of copper wire.

2. Using a hand-crimp tool, crimp the ring-tongue terminal of M4 (for 800 W and 1100 W), M5 (for 1400 W) stud size to the green/yellow wire.
- ⓘ **NOTE:** Either a Straight or Right Angle ring-tongue terminal can be used. The Installation Electrician should decide which is best for the safety ground installation.
3. Remove the nut and associated hardware from grounding post/stud.
 4. Connect the safety ground to the grounding post/stud on the PSU using the nut, Spring Washer and Locking/Star Washer removed in step 3.

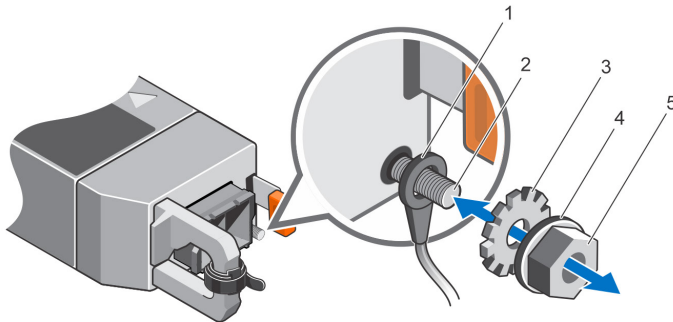

Connection using Straight Type Ring-Tongue Terminal

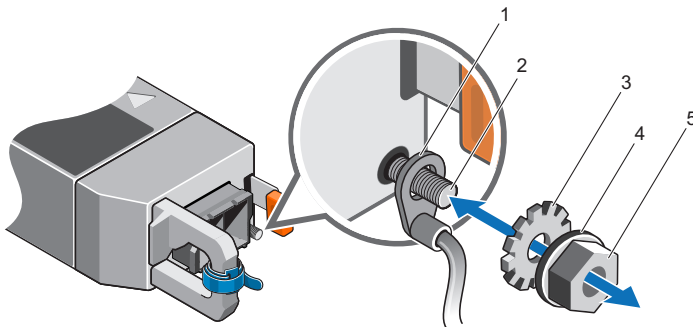

Connection using Right Angled Type Ring-Tongue Terminal

- | | |
|------------------------------------|------------------------|
| 1. Green/Yellow safety ground wire | 2. Grounding post/stud |
| 3. Locking/star washer | 4. Spring washer |
| 5. Nut | |

i NOTE: The system shown above is indicative only and may not match the actual system that you purchased.

2. Assembling the DC power cable

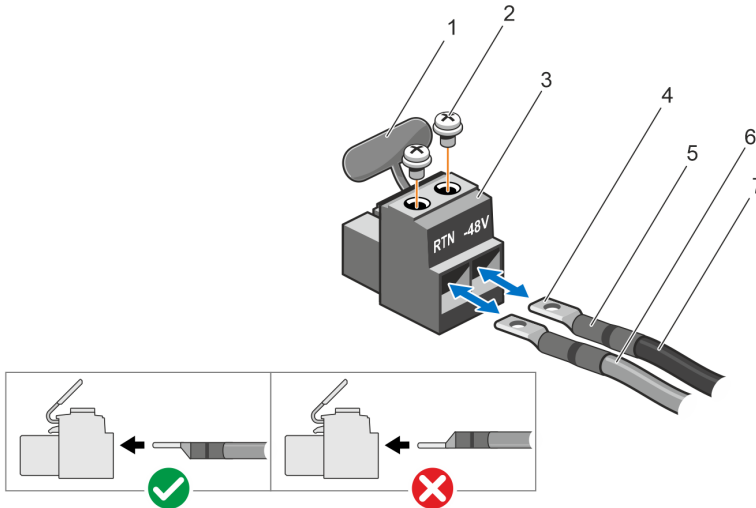

1. Cap on plug
2. Screws on the plug
3. Input plug
4. Crimp terminals
5. Heat shrink tubing
6. Red wire
7. Black wire

To construct the DC input power cable, perform the following steps:

1. Strip the insulation from the end of the DC power wires (size as defined in table above) such that ends are exposed to match the crimp terminal.
2. Twist and reshape the exposed stranded wires.
3. Crimp black and red wires into crimp terminals using hand-crimping tool.
4. Insert suitable heat shrink tubing (not supplied as part of the kit) over each crimp terminal head so that it covers the length of the barrel and extend approximately about an inch on the wires.
5. Using a heat gun or suitable tool shrink the tubing so it sits snug on the barrel and wire.
6. Insert the black wire into input plug position marked -48 V . The crimp terminal must be properly oriented as shown in the image.
7. Insert the red wire into input plug position marked RTN . The crimp terminal must be properly oriented as shown in the image.
8. Secure both black and red wires into the input plug using the screws (use torque setting of $2.7\text{Nm} \pm 5\%$ ($23.9\text{ in-lbs} \pm 5\%$)) and insert the cap over the screws. The screw is intended to go through the hole in the crimp terminal. Ensure that the cap is

inserted properly and the crimp terminal is secured with the screw by lightly tugging on the cables.

⚠ **CAUTION:** Damage can occur if the crimp terminals are not fully inserted into the plug before tightening the screws.

⚠ **WARNING:** Failure to follow the documented assembly instructions could result in potential property damage, personal injury or death.

3. Connecting the $-(48-60)$ V DC power cable

1. To connect the $-(48-60)$ V DC power cable, use the VELCRO® strap to loop the cables to the PSU handle.

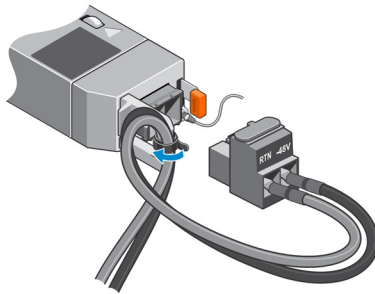

2. Plug the $-(48-60)$ V DC power supply unit into the system.

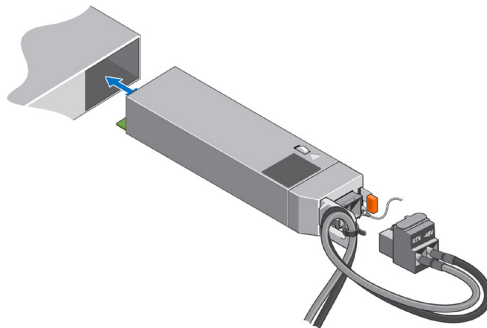

3. Insert DC cable assembly into PSU side connector and press the connector until it clicks in place.

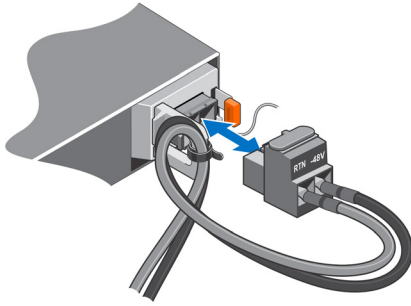

△ **CAUTION:** The input plug must be fully inserted into the power supply connector.

△ **WARNING:** The DC power source must be turned off before inserting the input plug into the power supply connector. The DC power supply is not hot pluggable.