



SMART Board RX series with iQ



Display	
Screen sizes (diagonal)	65" 75" 86"
Backlight	LED
Aspect ratio	16:9
Maximum display resolution	4K UHD (3840 × 2160)
Refresh rate	60 Hz
Lifespan	≥ 50,000 hours
Brightness¹	490 cd/m ²
Display response time	≤ 8 ms
Viewing angle	178°
Glass	Optically bonded Anti-glare Anti-fingerprint Heat-tempered
Frame color	White
Convenience buttons	Power Home Volume Microphone mute Freeze frame
Sensors	Proximity Ambient light Infrared Room temperature Humidity Equivalent carbon dioxide (eCO ₂) Volatile organic compound (VOC) Particulate Matter (PM _{2.5}) ²
Audio	Integrated soundbar featuring two 20 W speakers and a 15 W subwoofer Integrated linear eight-microphone array with visual mute status indicator and support for onboard acoustic echo cancellation

NFC

Integrated RFID NFC reader/writer CCID (chip card interface device) when used with a native operating system driver for Windows®, Linux®, or Mac

Supported protocols: ISO 14443A/B, ISO 15693, NFC Tag 1-4

Interactive experience

Touch technology	HyPr Touch™ with Advanced IR
Touch features	Tool Explorer™ (V2) Simultaneous tool differentiation Object Awareness™ Pen ID™ Silktouch™ Palm rejection
Typical touch response time	≤ 4 ms
Frame rate	≥ 300 Hz
Accuracy	1 mm
Minimum object size	2 mm
Multitouch capabilities	Up to 50 touch points (OS dependent)
Tools included	Stylus with multi-color select and fine eraser (×2) Erasers with angle of orientation (×2)
Tool holders	Intelligent Magnetic Frame-mounted
Optional tools	Stamps and cubes

¹Brightness of individual displays can vary.

²The display's environmental sensors are not life safety rated sensors: they provide general information only.

Software	
Included	iQ embedded Android™ OS SMART Notebook® SMART Product Drivers and SMART Ink® SMART Remote Management ³
Optional	SMART Notebook Plus Lumio™

iQ embedded Android OS	
Operating system	Android version 13.0 Supports an automatic update to Android 15
CPU	Octa-core
Memory	8 GB DDR4
OS architecture	64-bit
Storage	64 GB (up to 576 GB)
User interface	4K UHD (3840 × 2160)
Digital whiteboard	✓
Web browser	✓
Screen sharing	✓
Google Play™ Protect Certified⁴	✓
Google Play Store	✓
Other features	Personalized home screen and settings Split screen Interactive widgets Templates, graphic organizers, and manipulatives File and app libraries Environmental sensors dashboard Tool Explorer™ Image Editor
Ability to run third-party applications	✓
Cloud storage access	✓
NFC sign in to a SMART Account	✓
Device-based sign in to a SMART Account	✓

³Subscription for the length of the included warranty

⁴Pending final testing

Languages supported	Basque Catalan/Valencian Chinese (simplified) Chinese (traditional) Czech Danish Dutch English Estonian Finnish French Galician German Greek Hungarian Italian Japanese Korean Latvian Lithuanian Norwegian Polish Portuguese Romanian Russian Slovak Slovenian Spanish Swedish Ukrainian Vietnamese Welsh
Updates	Automatic over-the-air (OTA)

PC computing	
OPS support⁵	SMART PCM modules
PC module power supported OPS	100 W
Optional computing module	See > smarttech.com/accessories

Inputs	Front	Back
OPS PC accessory slot	–	1
MicroSD slot with security cover	–	1
HDMI® 2.1 4K @ 60Hz with HDCP 1.4, HDCP 2.3, ARC, and eARC support ⁶	1	3
VGA video	–	1
RS-232 (DB-9 connector)	–	1
RJ45 (LAN In)	–	1
USB Type-C 4K @ 60Hz, Display Port 1.2, USB 2.0 (UFP) for touch and digital audio, USB 3.2 Gen 1 (DFP) for peripherals; 65 W power delivery	1	1
USB Type-C, SuperSpeed (5 Gbps); 15 W power delivery	–	1 (top) 1 (top)
USB 2.0 Type-A	–	1
USB 3.2 Gen 1 Type-A	2	2
USB 3.2 Gen 1 Type-B	1	3

⁵The support and performance of third-party OPS (Open Pluggable Specification) and OPS-C modules may vary. Conduct proper compatibility testing to avoid potential issues.

⁶ARC and eARC support are available only with the HDMI 2 input.

SMART Board RX series with iQ

Outputs	Front	Back
HDMI 2.1 4K @ 60Hz with HDCP 2.3 support	–	1
USB Type-C 4K @ 60Hz Display Port 1.4a, HDCP 2.3 and HDCP 1.3, USB 3.2 Gen 1 (DFP) for touch ingest and peripherals; 4.5 W power delivery	–	1
Stereo 3.5 mm (variable)	–	1
S/PDIF optical (fixed)	–	1
RJ45 (LAN Out)	–	1

Included cables and accessories	Qty
Country-specific power cable	1
16' 5" (5 m) USB 2.0 A to B cable	1
6' (1.8 m) USB 3.2 Gen 1 Type-C cable, 5A	1
Stylus with multi-color select and fine eraser	2
Bar erasers	2
External tri-band Wi-Fi (2.4, 5, and 6–7.2 GHz) and Bluetooth® (2.4 GHz) antennas	2
Remote control	1
AAA batteries	2
SMART ID cards (for NFC sign in to a SMART Account)	2
Illustrated installation instructions	1
Important information document	1

Connectivity

Wired	RJ45 (×2) 1000BASE-T
Wi-Fi	IEEE 802.11ax (Wi-Fi 6e) supporting WPA, WPA2, WPA3 PSK, and 802.1X EAP authentication protocols
Bluetooth	5.2 dual mode

Storage and operating requirements

Power requirements	100V to 240V AC, 50 Hz to 60 Hz
Operating temperature	41–95°F (5–35°C)
Storage temperature	–4–140°F (–20–60°C)
Humidity	5–80% relative humidity, non-condensing

Power consumption

Typical	65": 94 W 75": 105 W 86": 122 W
Standby	<0.5 W

Certification and compliance⁷

Regulatory models	IDQR65-A IDQR75-A IDQR86-A
US / Canada	FCC ISED TSCA CONEG Packaging Proposition 65
EU / EEA / EFTA / UK	CE UKCA LVD CB EMC RED REACH RoHS Battery WEEE Packaging POP Ecodesign
Australia / New Zealand	RCM
Performance standards	ENERGY STAR® HDMI HDCP

Purchasing information⁸

Order numbers	
RX265	SMART Board® RX065 interactive display with iQ
RX275	SMART Board RX075 interactive display with iQ
RX286	SMART Board RX086 interactive display with iQ

Optional accessories

SWC-120UHD	SMART Ultra HD Camera 120
TE-4CUBE-V2	Tool Explorer (V2) cubes
TE-4STAMP-V2	Tool Explorer (V2) stamps
Other accessories	See > smarttech.com/accessories

SMART Warranty

Terms and conditions and warranty upgrade options vary by region. Visit smarttech.com/warranty or contact your reseller for information.

⁷Product availability may vary by region.

This product has received additional certifications not listed here.

⁸Order numbers may vary by region.

Cable requirements

See > *SMART cables and connectors guide*
(docs.smarttech.com/kb/171926)



Installation, dimensions, and weights

Notes

- All dimensions ± 1/8" (0.3 cm). All weights ± 2 lb. (0.9 kg).
- Product ships upright.
- Leave space around the display to ensure adequate ventilation.

65" models

Dimensions

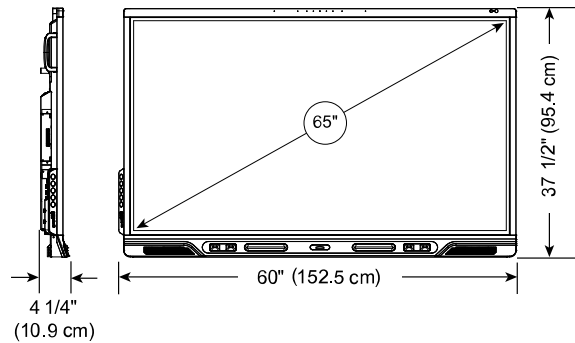

Weight

92.6 lb. (42 kg)

Shipping dimensions (including pallet)

65 1/2" × 46" × 7 1/8"
(166.5 cm × 117 cm × 18 cm)

Shipping weight

108 lb. (49 kg)

VESA mount

M8 | 600 × 400 mm

Handles

2

75" models

Dimensions

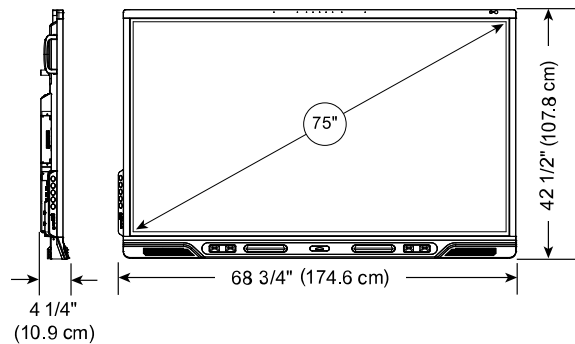

Weight

124 lb. (56 kg)

Shipping dimensions (including pallet)

74 5/8" × 50 7/8" × 7 1/8"
(189.5 cm × 129.3 cm × 18 cm)

Shipping weight

147 lb. (67 kg)

VESA mount

M8 | 800 × 400 mm

Handles

2

86" models

Dimensions

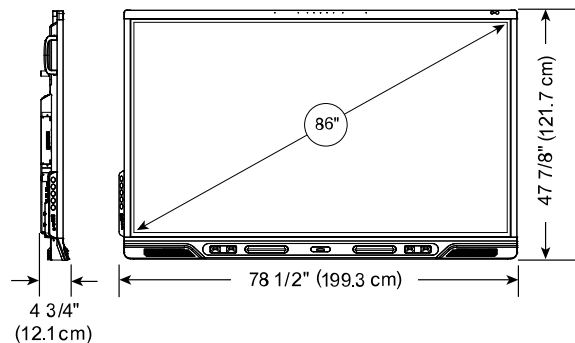

Weight

154 lb. (70 kg)

Shipping dimensions (including pallet)

84 1/4" × 57 1/4" × 7 5/8"
(214 cm × 145.4 cm × 19.5 cm)

Shipping weight

190 lb. (86 kg)

VESA mount

M8 | 800 × 600 mm

Handles

2

smarttech.com
smarttech.com/contact

© 2026 SMART Technologies ULC. All rights reserved. SMART Board, SMART Notebook, Lumio, SMART Ink, Tool Explorer, Simultaneous Tool Differentiation, Object Awareness, Pen ID, Silktouch, smarttech, the SMART logo and all SMART taglines are trademarks or registered trademarks of SMART Technologies ULC in the US and/or other countries. The Adopted Trademarks HDMI, HDMI High-Definition Multimedia Interface, and the HDMI Logo are trademarks or registered trademarks of HDMI Licensing Administrator, Inc. in the United States and other countries. The Bluetooth word mark is owned by the Bluetooth SIG, Inc. and any use of such marks by SMART Technologies ULC is under license. Android and Google Play are trademarks of Google Inc. All other third-party product and company names may be trademarks of their respective owners. This product and/or use thereof is covered by one or more of the following US patents: www.smarttech.com/patents. Contents are subject to change without notice. May 26, 2026.