

CyberPower

SMART APP ONLINE UPS SYSTEM

INSTALLATION AND OPERATION MANUAL

OL5KERTHDL/OL6KERTHDL

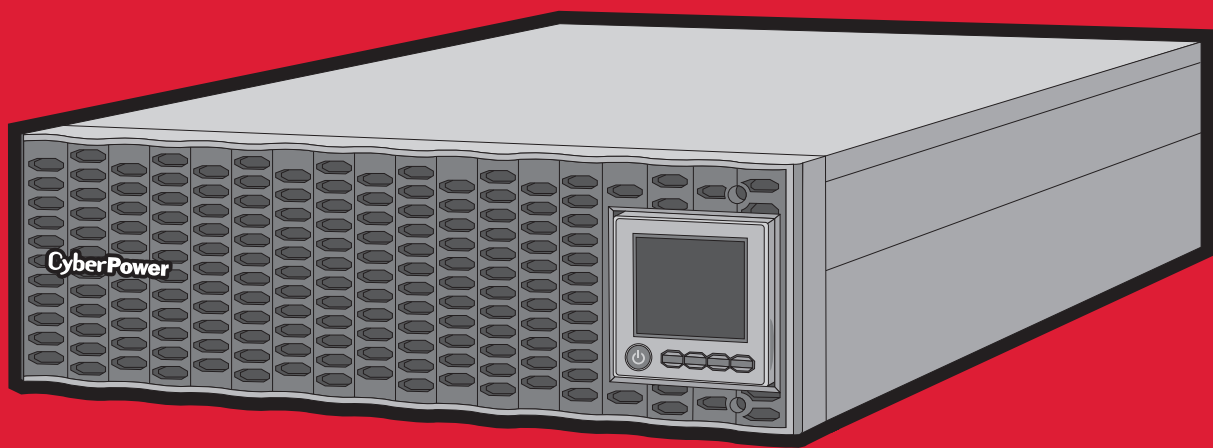

SAVE THESE INSTRUCTIONS

Please read this manual and follow the instructions for installation and operation.

SAFETY INSTRUCTIONS

SAVE THESE INSTRUCTIONS

This manual contains important instructions that should be followed during installation and maintenance of the UPS and batteries.

The Smart App Online 5-6kVA UPS models that are covered in this manual are intended for installation in an environment within 32°F to 104°F (0°C to 40°C), free of conductive contaminants.

SPECIAL SYMBOLS



Warning: High voltage – Risk of Electric Shock



Caution - Important Instructions: Must always be followed.



Do Not Discard: The UPS or UPS batteries in trash. The batteries contain lead acid. For more information, contact your local recycling or hazardous waste facility.



Information, advice, help



See applicable user manual

SAFETY INSTRUCTIONS CONT.

PERSONAL SAFETY

CAUTION



To reduce the risk of fire, connect the UPS to a branch circuit with 50 amperes (5,000/6,000 VA) maximum over-current protection in accordance with the National Electric Code, ANSI/NFPA 70.

The AC electrical service where the UPS is connected should be close to the unit and easily accessible.

Please use only VDE-tested, CE-marked mains cable, (e.g. the mains cable of your equipment), to connect the UPS to the AC outlet.

Please use only VDE-tested, CE-marked power cables to connect any equipment to the UPS.

When installing the equipment, ensure that the sum of the leakage current of the UPS and the connected equipment does not exceed 3.5mA.

Do not unplug the unit from AC power during operation, as this will disconnect the protective ground insulation.

Do not use an improper size power cord as it may cause damage to your equipment and cause fire hazards.

Make sure everything is turned off and disconnected completely before conducting any maintenance, repairs or shipment.

DO NOT INSTALL THE UPS WHERE IT WOULD BE EXPOSED TO DIRECT SUNLIGHT OR NEAR A STRONG HEAT SOURCE!

DO NOT BLOCK OFF VENTILATION OPENINGS AROUND THE HOUSING!

DO NOT CONNECT DOMESTIC APPLIANCES SUCH AS HAIR DRYERS TO UPS OUTPUT SOCKETS!

SERVICING OF BATTERIES SHOULD BE PERFORMED OR SUPERVISED BY PERSONNEL KNOWLEDGE OF BATTERIES AND THE REQUIRED PRECAUTIONS. KEEP UNAUTHORIZED PERSONNEL AWAY FROM BATTERIES!

FOR PERMANENTLY CONNECTED EQUIPMENT, A READILY ACCESSIBLE DISCONNECT DEVICE SHALL BE INCORPORATED IN THE BUILDING INSTALLATION WIRING.

SAFETY INSTRUCTIONS

PERSONAL SAFETY CONT.

RISK OF ELECTRIC SHOCK



A battery can present a risk of electric shock and high short circuit current. The following precaution should be observed when working on batteries:

Remove watches, rings or other metal objects.

Use tools with insulated handles.

The UPS must be connected to a grounded AC power outlet with fuse or circuit breaker protection. DO NOT plug the UPS into an outlet that is not grounded. If you need to power-drain this equipment, turn off and unplug the unit.

(No User Serviceable Parts): Risk of electric shock, do not remove cover. No user serviceable parts inside. Refer servicing to qualified service personnel.

To prevent the risk of fire or electric shock, install in a temperature and humidity controlled indoor area, free of conductive contaminants. (Please see specifications for acceptable temperature and humidity range).

To avoid electric shock, turn off and unplug the unit before installing the input/output power cord with a ground wire. Connect the ground wire prior to connecting the line wires!

Connect the Protection Earth (PE) safety conductor before any other cables are connected.

(Fuses): To reduce the risk of fire, replace only with the same type and rating of fuse.

SAFETY INSTRUCTIONS CONT.

PRODUCT SAFETY

RISK OF ELECTRIC SHOCK

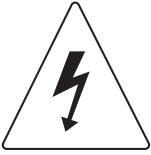

The battery can power hazardous components inside the unit, even when the AC input power is disconnected.

The UPS should be placed near the connected equipment and easily accessible.

(Non-Isolated Battery Supply): Risk of electric shock, battery circuit is not isolated from AC power source; hazardous voltage may exist between battery terminals and ground. Test before touching.

All UPS models covered in this document are permanently-connected equipment and only qualified maintenance personnel may carry out installations.

Wiring must be done by qualified personnel.

DO NOT USE FOR MEDICAL OR LIFE SUPPORT EQUIPMENT! Under no circumstances should this unit be used for medical applications involving life support equipment and/ or patient care.

DO NOT USE WITH OR NEAR AQUARIUMS! To reduce the risk of fire, do not use with or near aquariums. Condensation from the aquarium can come in contact with metal electrical contacts and cause equipment to short out.

The unit has a dangerous amount of voltage. When the UPS indicators is on, the units may continue to supply power thus the unit's outlets may have a dangerous amount of voltage even when it's not plugged in to the wall outlet.

BATTERY



Do not dispose of batteries in fire as the battery may explode.

Do not open or mutilate the battery, released electrolyte is harmful to the skin and eyes.

TABLE OF CONTENTS

SAFETY INSTRUCTIONS	II
Special Symbols	II
Personal Safety	III
Product Safety	V
INTRODUCTION.....	1
Smart App Online UPS Systems.....	1
UPS Extended Battery Modules	1
Unpacking Procedures	2
Whats In The Box	3
OVERVIEW	4
Power Module	4
INSTALLING YOUR UPS SYSTEM.....	6
System Block Diagram	6
Hardware Installation Guide.....	6
HARDWARE INSTALLATION	8
Rackmount Installation.....	8
Vertical/Tower Installation.....	10
ELECTRICAL INSTALLATION	11
Connecting Internal Battery.....	11
Input/Output Configuration.....	12
UPS SYSTEM STARTUP.....	14
USING THE UPS SYSTEM.....	15
LCD Panel.	15
Function Tree.....	19
Troubleshooting	34
MAINTENANCE	37
Battery Replacement.....	37
TECHNICAL SPECIFICATIONS.....	40
TROUBLESHOOTING	42

INTRODUCTION

CyberPower Smart App Online rack/tower UPS systems, with double-conversion topology, provide sine wave output to mission-critical applications and equipment requiring seamless power correction. These units offer generator compatibility and deliver clean AC power with zero transfer time.

They offer Smart Battery Management (SBM), which helps extend overall battery life, and Fast Charge Technology, which helps keep charge times to less than four hours, regardless of the number of Extended Battery Modules (EBMs). Features include energy-saving GreenPower UPS™ ECO Mode technology, and PowerPanel® Business Edition software for monitoring and managing the UPS.

UPS EXTENDED BATTERY MODULES

Extended Battery Modules (EBMs) from CyberPower (BPE144VL2U01) increase battery runtimes during power outages. Each rack/tower convertible EBM uses 2U of rack space, depending upon the model, and can be installed in a tower form factor to match the UPS installation. The DC plug-and-play power connectors allow to daisy-chain additional EBMs to a UPS system. EBMs compatible with Smart App Online UPS systems also have a built-in battery charger, providing Fast Charge Technology to quickly restore the backup power supply.

INTRODUCTION CONT.

UNPACKING PROCEDURES



Information, advice, help

The UPS system is very heavy, please handle with care. Wear safety shoes and use a hydraulic equipment lift if one is available. At least two people are required for all handling operations, including unpacking, lifting, and installation in a rack system. Do not use the lifting straps to carry the unit around; they are provided to manually unpack the unit only. Do not lift the unit by the rackmount ears.

! CAUTION – HEAVY OBJECT

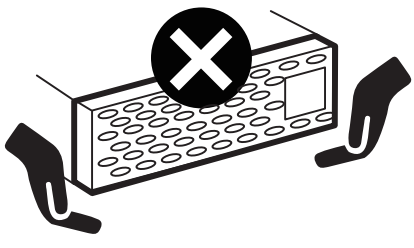
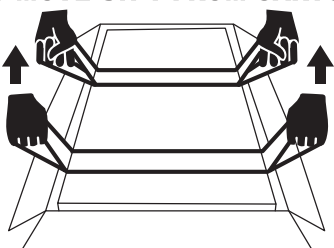
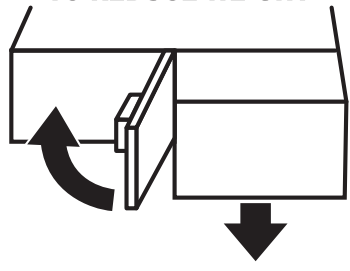
<p>• DO NOT LIFT BY FRONT PANEL</p> 	<p>• USE LIFTING STRAPS TO MOVE UNIT FROM CARTON</p> 	<p>• PULL BATTERY PACKS OUT TO REDUCE WEIGHT</p> 
---	--	--

Please remove the protective film before use.
At least two people are required for all handling operations.

Please follow the unpacking procedures as below to move the unit from the carton.

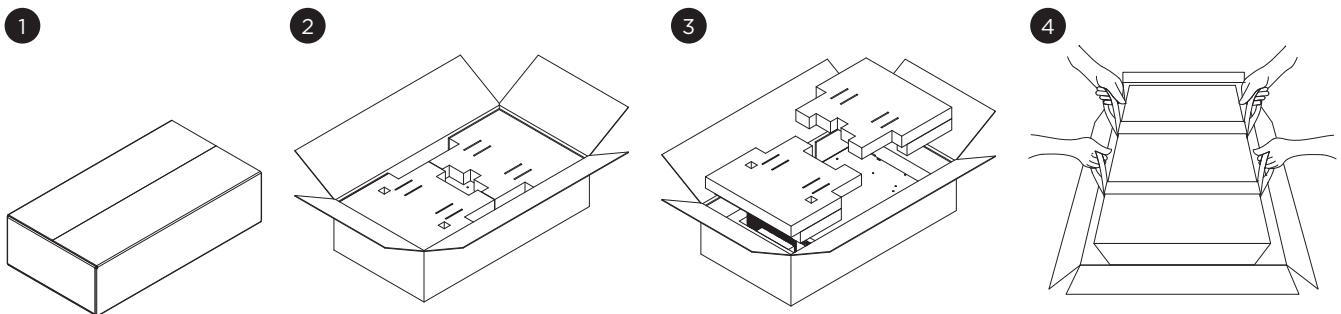

INTRODUCTION CONT.

WHAT'S IN THE BOX

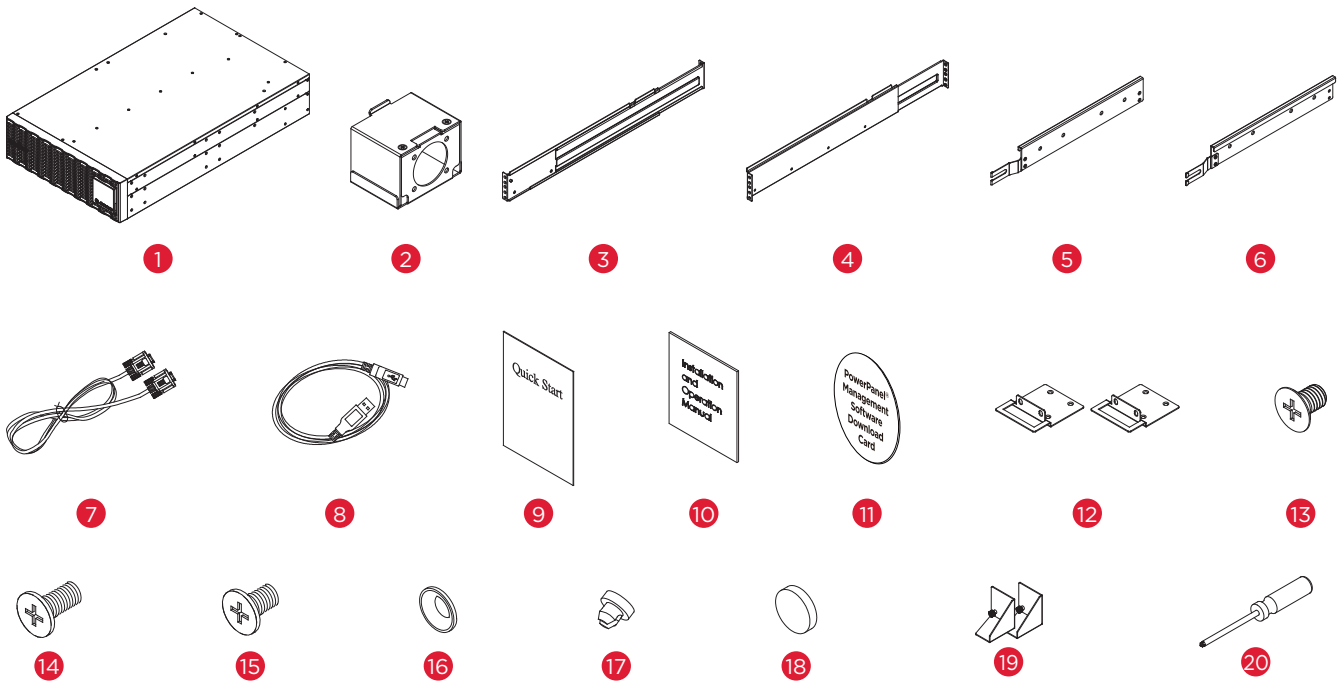

ITEM	CONTENT	QTY	ITEM	CONTENT	QTY
1	UPS	1	11	PowerPanel Management Software Download Card	1
2	Input/output terminal block cover	2	12	Rackmount ears	2
3	Rackmount left rail	1	13	Flat head screws M5X7L	8
4	Rackmount right rail	1	14	Pan head screws M5X8L	12
5	Left hanging bracket	1	15	Pan head screws M5X6L	6
6	Right hanging bracket	1	16	Plastic washers	8
7	Serial Interface Cable (RS-232)	1	17	Screw hole dust covers	18
8	USB communication cable	1	18	Rubber pads	12
9	Quick Start Guide	1	19	Stand	2
10	Installation and Operation Manual	1	20	Screwdriver	1

OVERVIEW

POWER MODULE

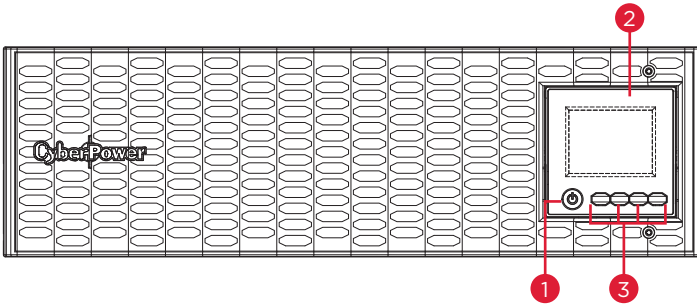

OL5KERTHDL / OL6KERTHDL

1. Power Button / Power on Indicator

Master ON/OFF switch for the UPS. Indicates that the UPS is on and supplying power.

2. UPS Status / Multifunction LCD Readout

Shows UPS status, information, settings and events.

3. Function Buttons

Scroll DOWN scroll UP, ENTER, and ESCAPE.

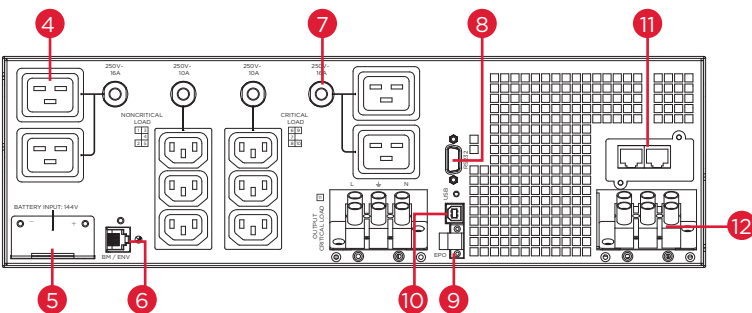

OL5KERTHDL / OL6KERTHDL

4. Battery Backup & Surge Protected Outlets

Provides battery backup and surge protection. They ensure power is provided to connected equipment over a period of time during a power failure.

Critical / Noncritical Load

Allows the creation of load priorities to ensure that battery power reserves are transferred to specified outlets during a power outage. The unit can be programmed to provide additional runtime for equipment connected to the “CRITICAL” outlets, while stopping the power supply to equipment connected to “NONCRITICAL” outlets after a designated period of time.

5. Extended Runtime Battery Module Connector

Connection for additional CyberPower External Battery modules.

OVERVIEW CONT.

POWER MODULE CONT.

6. BM/ENV Port

The port supports External Battery Modules detection.

7. Output Circuit Breaker

Provides output current overload and fault protection.

8. Serial Port

Serial port provides RS-232 communication between the UPS and a computer. The UPS can trigger a computer with PowerPanel® Business Edition software installed to shut down during a power outage through the connection while the computer can monitor the UPS and change its various programmable settings.

9. EPO (Emergency Power Off) Connector

Enables an emergency UPS power-off from a remote location.

10. USB Port

USB port provides communication between the UPS and a computer. The UPS can trigger a computer with PowerPanel® Business Edition software installed to shut down during a power outage through the connection while the computer can monitor the UPS and change its various programmable settings.

11. Expansion Slot

A network remote management card is pre-installed in the expansion slot.

12. Input Terminal Block

Connect to utility power.

INSTALLING YOUR UPS SYSTEM

SYSTEM BLOCK DIAGRAM

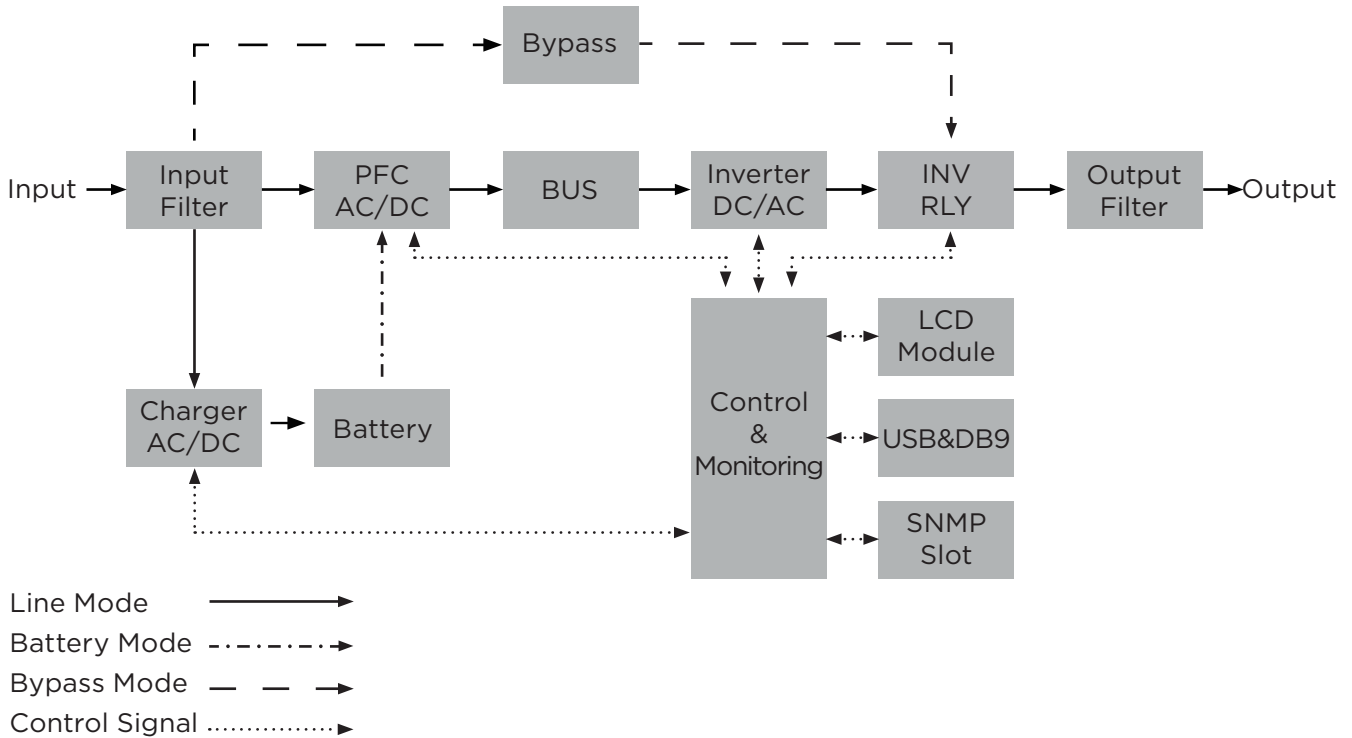

HARDWARE INSTALLATION GUIDE

1. Battery charge loss may occur during shipping and storage. Before using the UPS, it's strongly recommended to charge batteries for four hours to ensure the batteries' maximum charge capacity. To recharge the batteries, simply connect the UPS to its designated AC electrical service.
2. When using PowerPanel® Business Edition software, connect either the serial or the USB cable between the computer and the corresponding port on the UPS. Note: If the USB port is used, the serial port will be disabled. They cannot be used simultaneously. After connecting to either the USB port or the serial port on the UPS, a computer with PowerPanel® Business Edition Agent software installed can control the operating schedule, battery test, outlets, as well as obtain UPS status information. However, other computers with PowerPanel® Business Edition Client software can only obtain UPS status information via LAN connection.
3. Connect your computer, monitor, and any externally-powered data storage device (Hard drive, Tape drive, etc.) into the outlets only when the UPS is off and unplugged. DO NOT plug a laser printer, copier, space heater, vacuum, paper shredder or other large electrical device into the UPS. The power demands of these devices will overload and possibly damage the unit.

INSTALLING YOUR UPS SYSTEM CONT.

HARDWARE INSTALLATION GUIDE CONT.

4. Press the ON/OFF switch to turn the UPS on. The Power-On indicator LED will turn on when activated. If an overload is detected, an audible alarm will sound and the UPS will continuously emit two beeps per second. For resetting the unit, unplug some equipment from the outlets. Make sure your equipment carries a load current within the unit's safe range, (refer to the technical specifications).
5. This UPS is equipped with an auto-charge feature. When the UPS is connected to AC electrical service the battery will automatically charge, even when the unit is switched off.
6. To maintain an optimal battery charge, leave the UPS connected to AC electrical service at all times.
7. Before storing the UPS for an extended period of time, turn the unit OFF. Then cover it and store it with the batteries fully charged. Recharge the batteries every three months to ensure good battery capacity and long battery life. Maintaining a good battery charge will help prevent possible damage to the unit from battery leakage.
8. The UPS has one USB port (default) and one serial port that allows connection and communication between the UPS and any attached computer running PowerPanel® Business Edition Agent software. The UPS can control the computer's shutdown during a power outage through the connection while the computer can monitor the UPS and alter various programmable parameters. Note: Only one communication port can be used at a time. The port not in use will automatically become disabled or the serial port will be disabled if both ports are attached.
9. EPO (Emergency Power Off) Port: EPO ports allow administrators the capability to connect the UPS unit to customer-supplied EPO switches. These installations give operators a single access point to immediately power-off all equipment connected to the UPS during an emergency.
10. To avoid electric shock, turn the unit OFF and disconnect the unit from utility power before hardwiring the UPS (in/out power cord). The in/out power cord MUST be grounded.
11. Please note the internal UPS temperature will increase when fans are not in operation or ventilation is obstructed. When the high temperature sensor activates protection, the UPS generates an alarm and shuts down to avoid unexpected equipment damage. When the over temperature occurs, please check the Troubleshooting section. If the condition persists, please contact CyberPower for technical support.

HARDWARE INSTALLATION

CyberPower UPS systems can be installed in a rackmount or vertical/tower orientation. This versatility is especially important to growing organizations with changing needs that value having the option to position a UPS on the floor or in a rackmount system. Note that the included rack mounting hardware is only compatible with square hole racks. Please follow the instructions below for the respective mounting methods.

RACKMOUNT INSTALLATION



Caution: Important Instructions

To prevent the risk of fire or electric shock, only use the supplied hardware to attach the mounting brackets.

Step 1: Remove the dust covers

Remove ten dust covers from the screw holes as shown below.

Step 2: Rackmount ear & hanging bracket installation

Attach two rackmount ears to the UPS using eight black M5X7L flat head screws and tighten two hanging brackets using six silver M5X6L pan head screws.

1

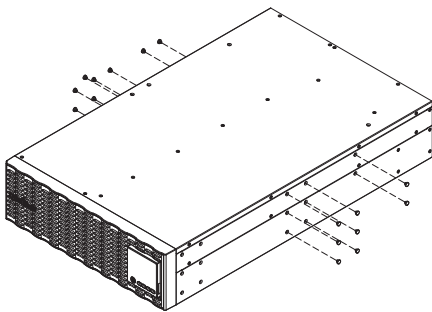

2

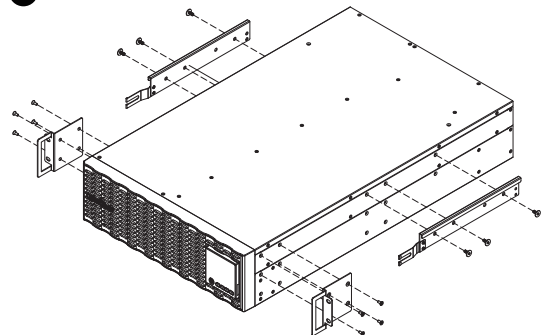

Step 3: Rackmount rail Installation

The mounting depth of the included rackmount rails can adjust from 20.5 in to 36 in (52 cm to 91.5 cm). Select the proper holes in the rack for positioning the UPS in the rack. The UPS takes up 2 rack units: rack hole positions 1 through 6.

Position the guide screws on the back of the rackmount rails into the rear rack square holes to temporarily support the rails in place.

Step 4: Adjust rackmount rails to fit your rack

Adjust the rail depth to match your rack depth. Attach each rackmount rail to your rack with two black M5X8L pan head screws and two plastic washers at the front of the rack (square holes 1 and 4 as shown below). Secure each rail to the rear of the rack with two black M5X8L pan head screws and two plastic washers.

HARDWARE INSTALLATION CONT.

RACKMOUNT INSTALLATION CONT.

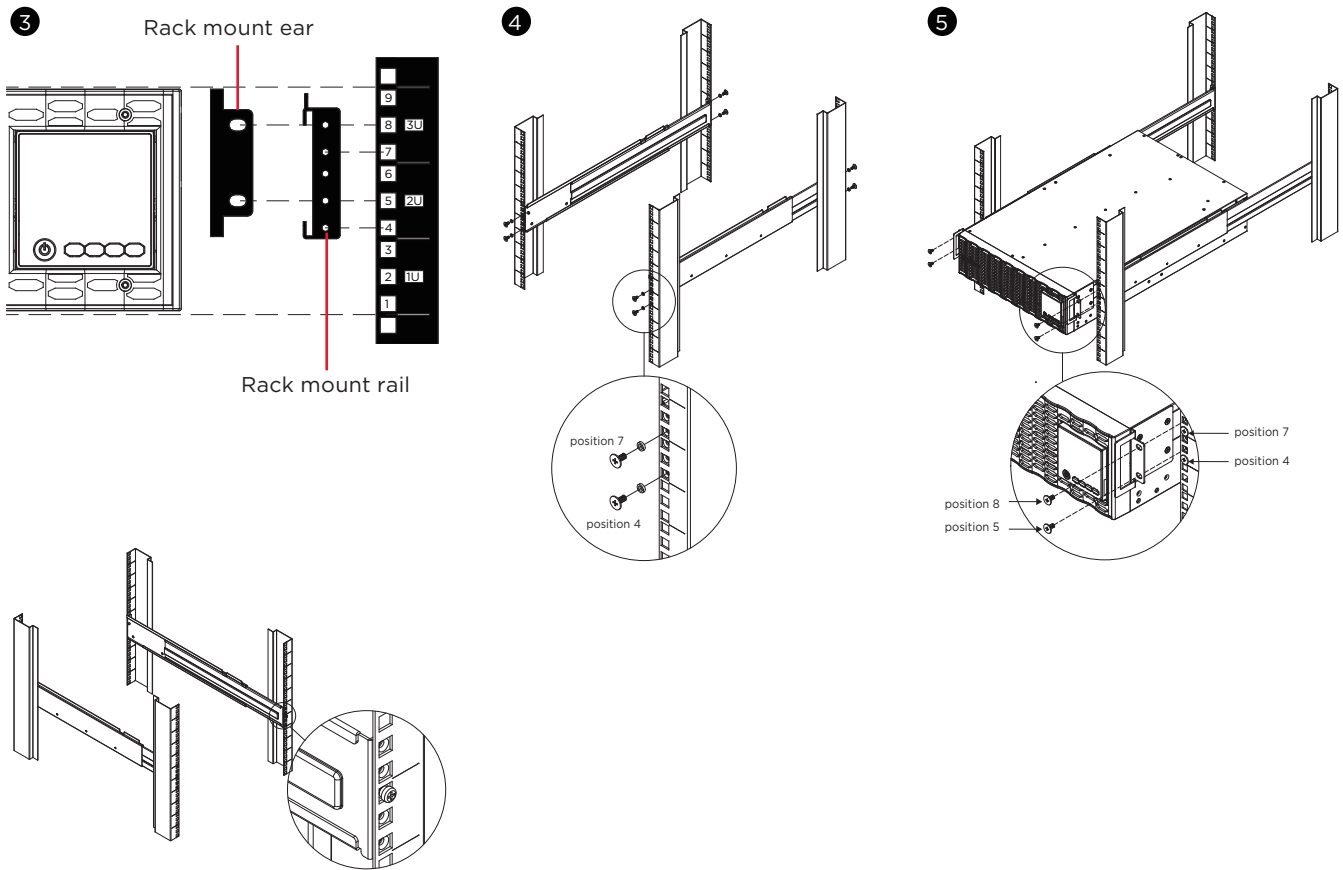

Step 5: Place and secure the UPS on the rails

Slide the hanging brackets on the UPS on to the rails mounted in the rack with the front of the unit facing toward you. Secure the UPS to your rack with four black M5X8L pan head screws at the front of the rack (square holes 2 and 5 as shown above).

NOTE: To slide the UPS out from the rack

The UPS will be secured by a safety locking mechanism midway of pulling it out of the rack. Use both hands to hold the UPS and press the safety locking tab to pull the UPS out.

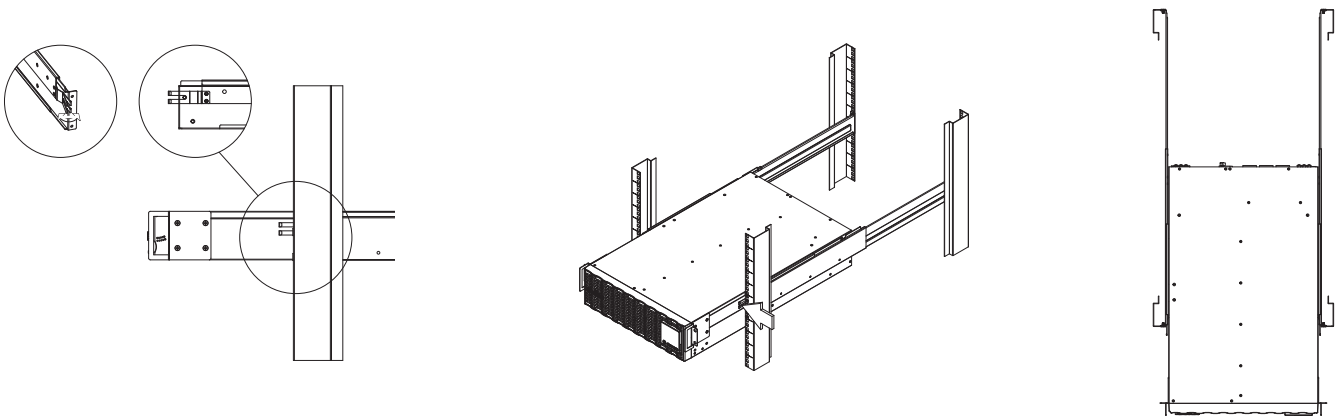

HARDWARE INSTALLATION CONT.

VERTICAL/TOWER INSTALLATION

Step 1: Adhere rubber pads

Adhere twelve circular rubber pads to the stands and to the left hand side of the UPS as shown below. This will become the bottom of the UPS. Insert the dust covers into the open screw holes on bottom.

Step 2: Attach the base stands and attach the dust covers

Stand the UPS system on its side and tighten the screws on the tower stands onto the bottom of the UPS as shown below. Insert the dust covers into the open screw holes on top.

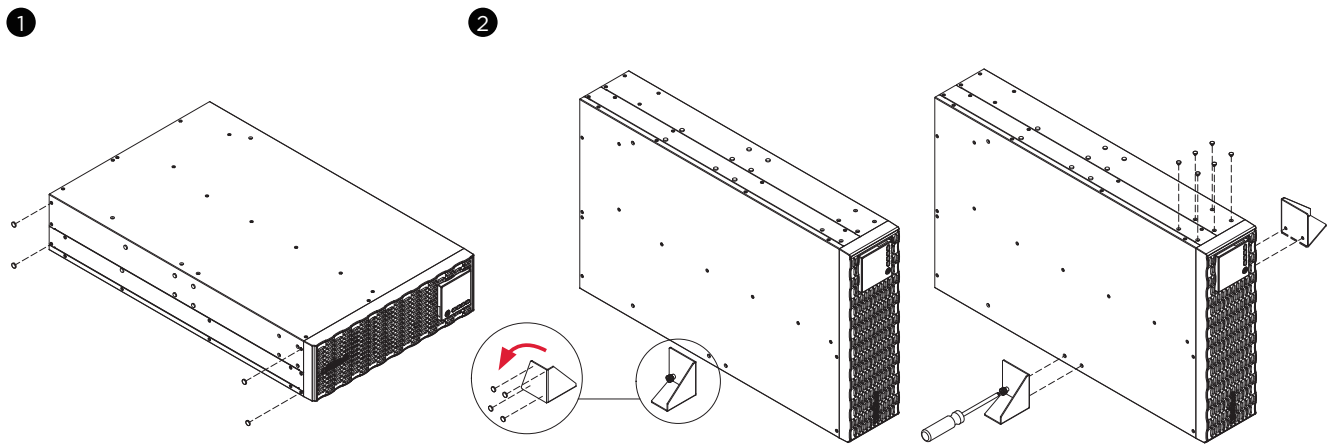

ELECTRICAL INSTALLATION

CONNECTING INTERNAL BATTERY

1. Unscrew and push the front panel to left side to remove it.
2. Unscrew and open the battery access door. This screw is designed to be fixed on the door, do not remove it from the metal cover.
3. Connect the internal battery connector. Ensure it is seated properly (connector will click into place).
4. Tighten the screw on the battery access door and install the front panel back. Push the front panel to left side. Tighten the screws on the front panel.

1

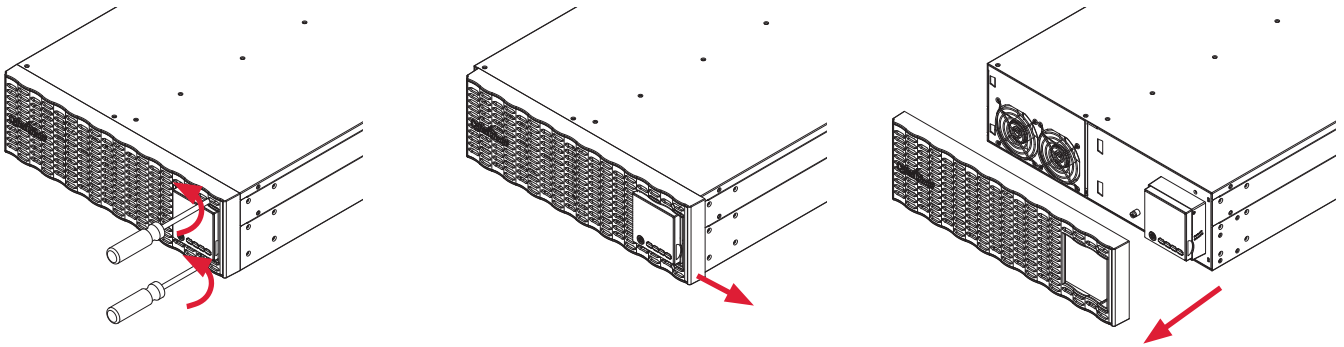

2

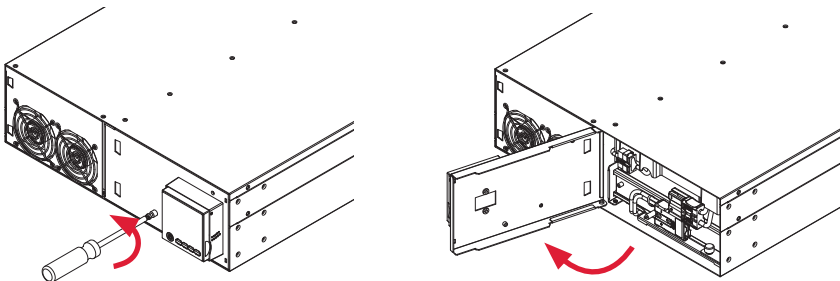

3

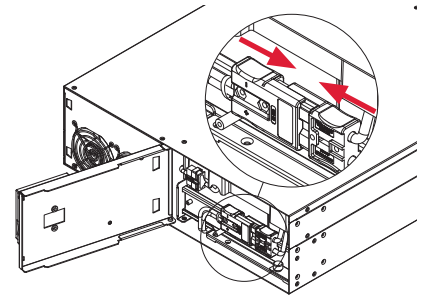

4

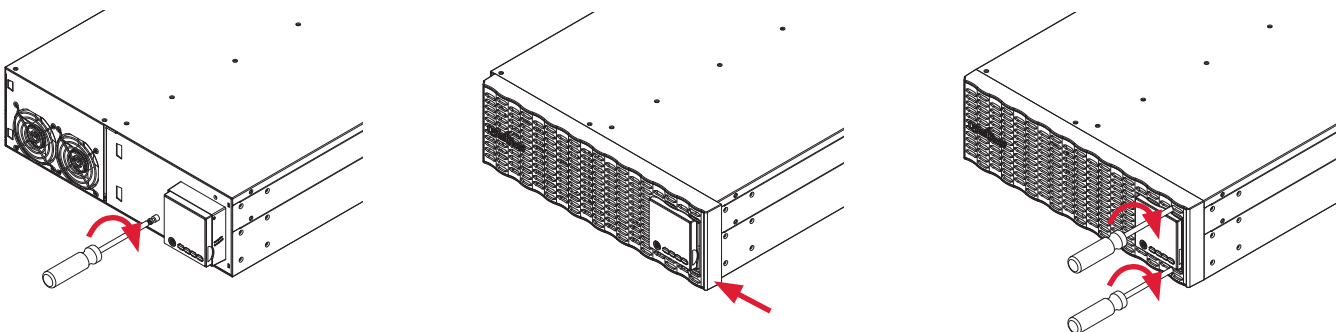

ELECTRICAL INSTALLATION CONT.

INPUT/OUTPUT CONFIGURATION

Verify branch circuit breaker rating and wiring dimensions with the following table for hardwired input UPS models.

UPS CAPACITY	BRANCH CIRCUIT BREAKER	WIRING AWG	WIRING mm ²	SCREW TORQUE lbf-in
5KVA	32 A	10 AWG	6.0 mm ²	18 lbf-in
6KVA	40 A	8 AWG	10 mm ²	

Hardwire the input/output terminals for OL6KERTHDL UPS models as shown in the following diagram.

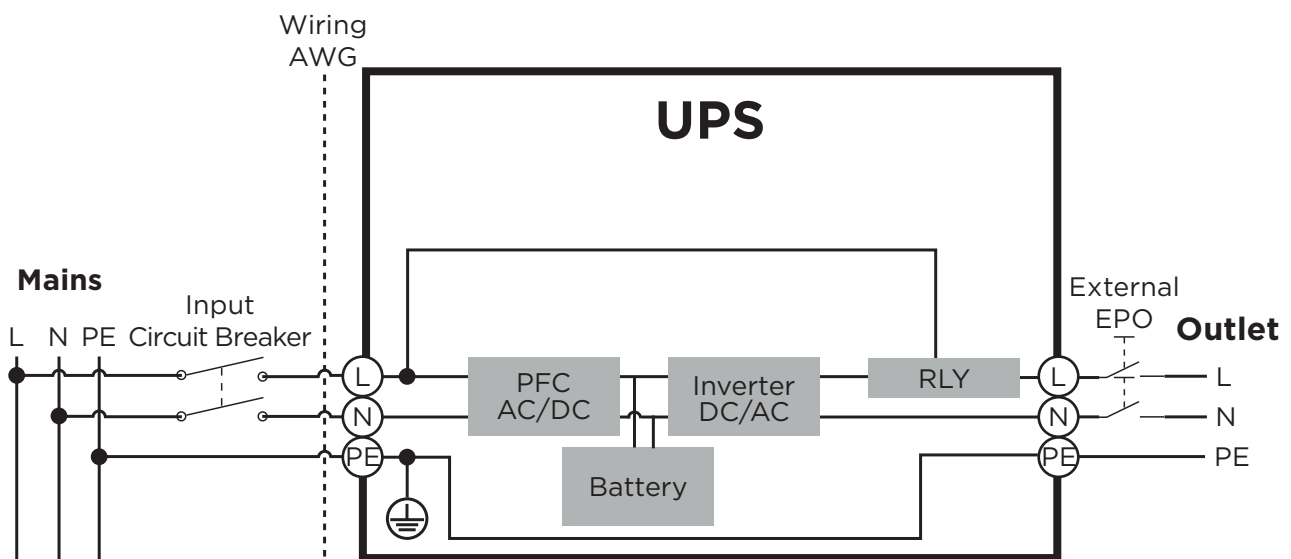

Caution: Important Instructions

Input and Output circuit breakers must be “OFF” during the installation process.

An additional two pole disconnect device is necessary during the installation process.

Disconnected EPO will immediately shut down the logic circuit output of the UPS. Wiring the EPO port is optional.

Local safety rules may require a separate, external EPO to turn off output circuit breakers. Refer to local wiring rules, the EPO should use approved components.

ELECTRICAL INSTALLATION CONT.

HARDWIRING THE INPUT/ OUTPUT TERMINALS

Step 1: Separate the top and bottom covers

Loosen the two screws to separate the INPUT/ OUTPUT top and bottom covers.

Step 2: Fix the appropriate cable gland (not included) on the bottom cover

Tighten the appropriate cable gland (not included) on the bottom cover by rotating it. Make sure the cable gland is fixed well on the bottom cover.

Step 3: Fix the bottom cover on the terminal block

Tighten the two screws to fix the INPUT/ OUTPUT bottom cover on the terminal block.

Step 4: Input configuration

Insert the input cable through the appropriate cable gland (not included). Connect the three wires to the input terminal block.

Step 5: Output configuration

Insert the output cable through the appropriate cable gland (not included). Connect the three wires to the output terminal block.

Step 6: Fix the top cover on the bottom cover

Tighten the two screws to fix the INPUT/ OUTPUT top cover on the bottom cover.

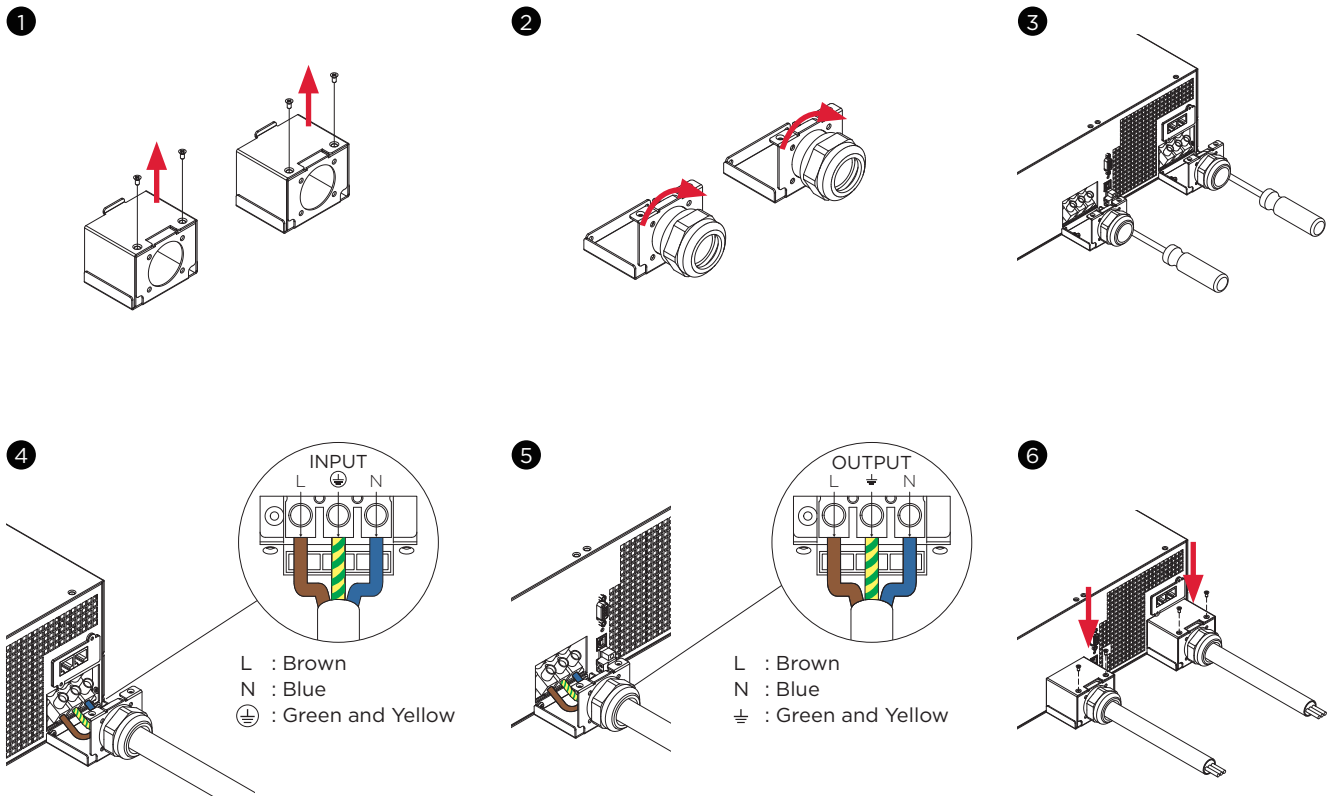

UPS SYSTEM STARTUP

After completing the hardware installation of the UPS, you are now ready to connect the UPS and connect your equipment.

To start the UPS:

1. Verify that the UPS input cable or terminal blocks are connected to AC source.
2. The UPS LCD shows “Standby Mode” and fans turn on.
3. Press the ON/OFF button on the UPS front panel for at least 3 seconds to turn On the UPS.
4. UPS will perform a brief self-test lasting about 15 seconds. The LCD will show result in the sequence below.
5. The UPS is operating in Battery Mode first then transfer to Line Mode if Input power is qualification and powering the output.

2



4

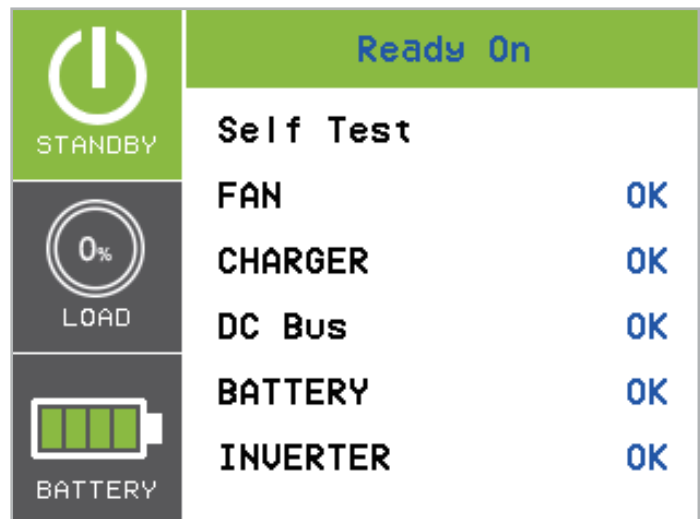

USING THE UPS SYSTEM

LCD PANEL



BUTTON OPERATION

ITEM	BUTTON	FUNCTION DESCRIPTION
1	ON/OFF	Press this button for at least 3 seconds to turn on or turn off UPS.
2	DOWN	Press this button to scroll down in the LCD menu.
3	UP	Press this button to scroll up in the LCD menu.
4	ENTER	Press this button to select an option.
5	ESC	Press this button to cancel or return to previous LCD menu.

USING THE UPS SYSTEM CONT.

LCD DISPLAY INTRODUCTION:

UPS Summary:

There are 2 display Zones: Icon Zone and Content Zone.

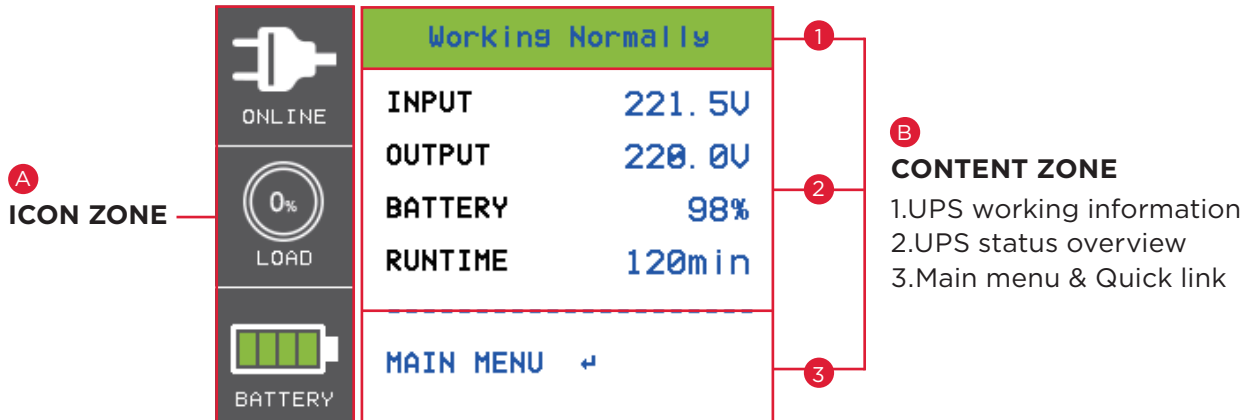

A ICON ZONE:

In the Left area, There are 3 ICONS for displaying the UPS working status / Load % / Battery Capacity and depend on UPS status changing the ICONS will display Warning and Fault with Yellow or RED color.

B CONTENT ZONE:







The Content area is on the middle and right screen.

- 1 The Top of Content area is for displaying UPS working information: Working Normally (Line Mode) / V+Hz out of range (Battery Mode) /Etc.
- 2 The central area is the UPS status which depends on different UPS status to provide different information included Input / Output / Battery / Load parameters.
- 3 The bottom area of content zone is the function select index included Main Menu and quick link selection which depends on different UPS status to provide relevant functional link.

Push Enter Button to Main Menu When UPS display the summary page.

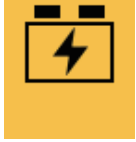
USING THE UPS SYSTEM CONT.

LCD SCREEN - UPS MODES OF OPERATION

UPS Mode (ICON)	UPS working information	UPS MODES DESCRIPTION
Standby Mode 	STANDBY	A utility power has been connected but UPS is Off.
Line Mode 	Working Normally	UPS is operating in Line Mode. The UPS is operating and protecting the equipment normally.
Battery Mode 	V+Hz out of range	UPS is operating in Battery Mode. A utility power failure (V+Hz/V/Hz out of range) has occurred. The UPS is using battery power to work and protect the equipment.
	V out of range	
	Hz out of range	
Bypass Mode 	Warning or Fault Information	UPS is operating in Bypass Mode. A Warning or fault has been detected and the UPS transfers output to utility power.
Manual Bypass Mode 	Manual Bypass	UPS is operating in Manual Bypass. The UPS has been manually transferred to bypass for maintenance purposes.
ECO Mode 	ECO Mode	UPS is operating in ECO (Economy) Mode. If Bypass quality is within the ECO mode setting specifications, the UPS will operate in Bypass until input power is disqualified per set specifications. At that time the UPS will automatically switch to Line Mode.

USING THE UPS SYSTEM CONT.

LCD SCREEN - UPS MODES OF OPERATION CONT.

LCD will use RED or Yellow color to indicate the Fault or warning status and also connect the color frame with ICON which has the same color and locates on the left zone of the screen.

The UPS status in the UPS Summary page will provide the related information by different working function..

The Function Select Menu in the UPS Summary page will provide the quick link to related function.

Battery Mode

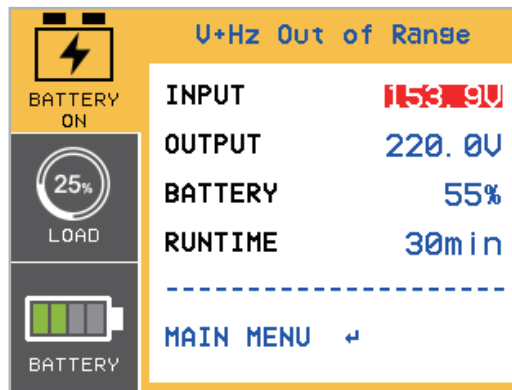

Output OverLoad

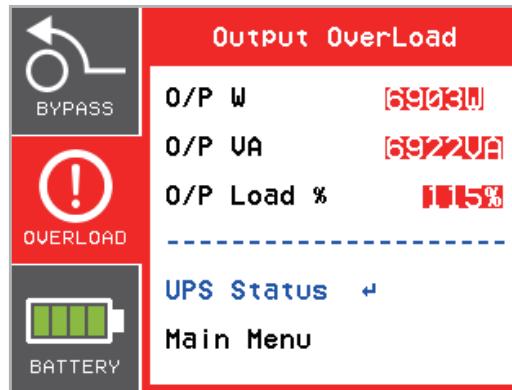

Press the “UP” and “DOWN” buttons to select the quick link function.
Push “Enter” Button to select function page.

USING THE UPS SYSTEM CONT.

FUNCTION TREE

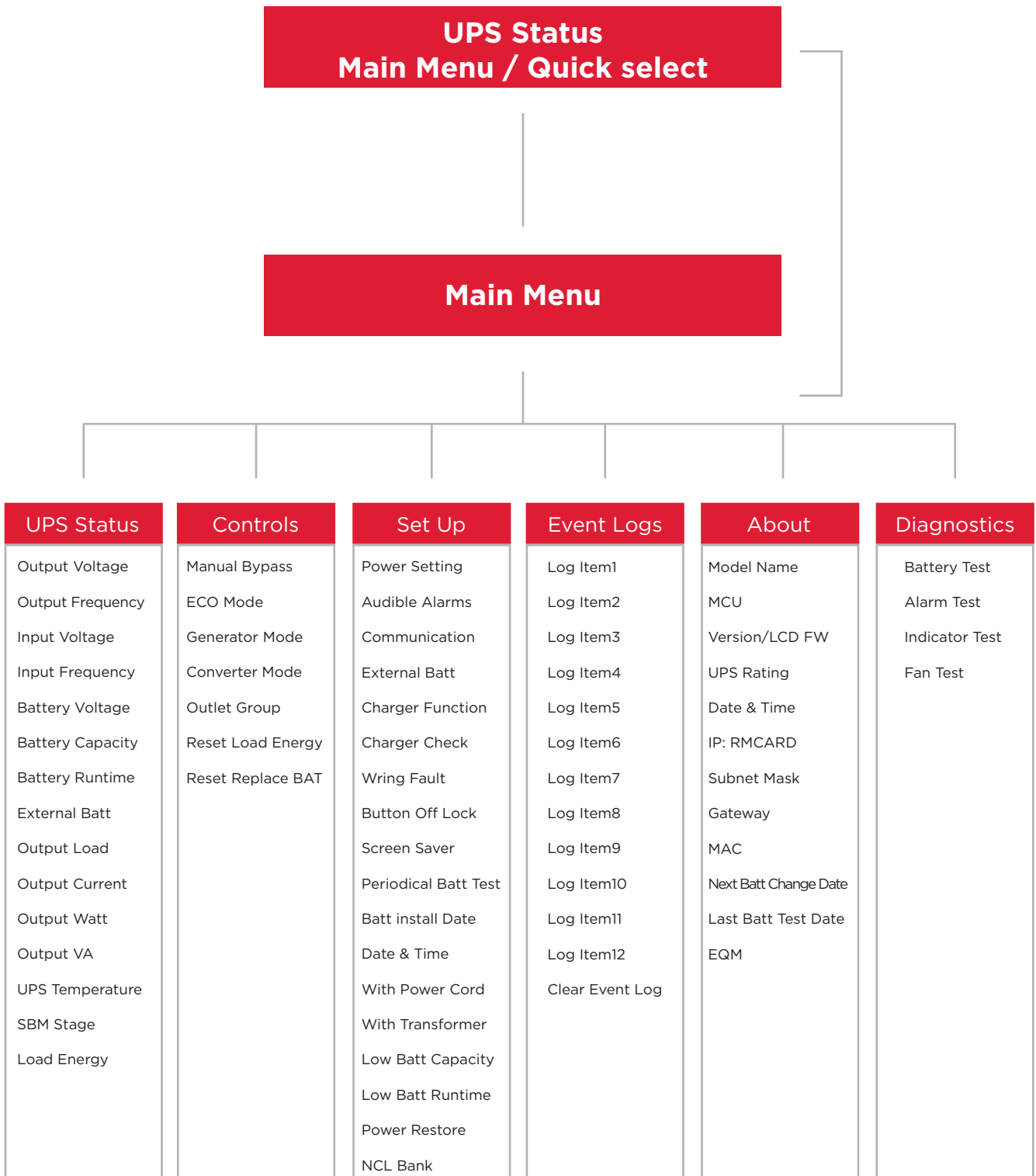

USING THE UPS SYSTEM CONT.

Main Menu: Function Select

The Main Menu has 6 icons of different function listed in the table below.

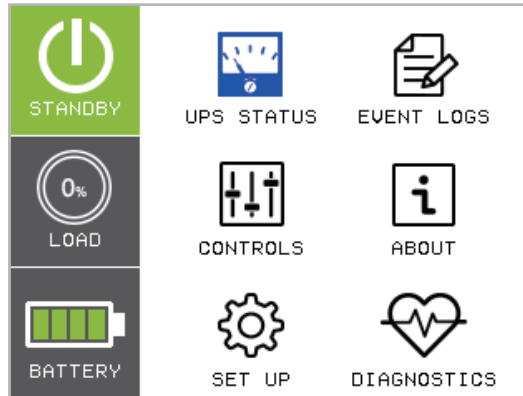

FUNCTION SELECT MENU	ICON	DESCRIPTION
UPS STATUS		Displays the UPS status.
CONTROLS		Displays the UPS Control items that can be set by the user.
SET UP		Displays the UPS Set Up items that can be configured by the user.
EVENT LOGS		Displays the 12 most recent events, by event count, time (Year/Month/Day Hour: Minute), and event description.
ABOUT		Displays the UPS information.
DIAGNOSTIC		Displays the UPS Diagnostics items that can be activated by the user.

USING THE UPS SYSTEM CONT.

(1) UPS STATUS

There are 15 types of UPS status Readout available for display.

1. Select “UPS Status” Icons
2. Press the “ENTER” button to enter the “UPS Status”.
3. Press the “UP” and “DOWN” buttons to scroll through the “UPS Status” items shown in the table below.
4. Press the “ESC” button to return to the Main Menu.

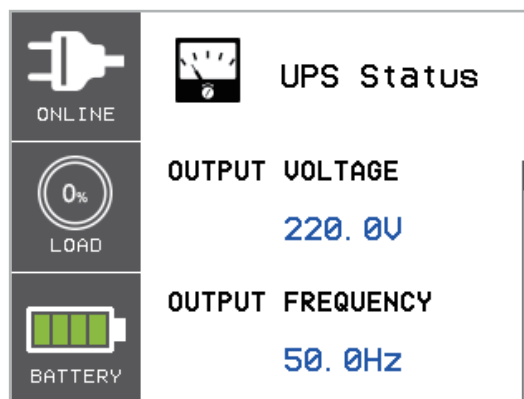

There is a Navigation bar on the right area of content zone; it will indicate the current page in Navigation Bar.

USING THE UPS SYSTEM CONT.

(1) UPS STATUS CONT.

UPS STATUS ITEMS	DATA DISPLAYED	DESCRIPTION
OUTPUT VOLTAGE	= XXX.XV	Displays the Output Voltage
OUTPUT FREQUENCY	= XX.XHz	Displays the Output Frequency
INPUT VOLTAGE	= XXX.XV	Displays the Input Voltage
INPUT FREQUENCY	= XX.XHz	Displays the Input Frequency
BATTERY VOLTAGE	= XXX.XV	Displays the Battery Voltage
BATTERY CAPACITY	= XXX%	Displays the Estimated Percentage of Battery Capacity
BATTERY RUNTIME	= XXXM	Displays the Estimated Battery Runtime in Minutes
EXTERNAL BATT	Manual / Auto= X	Displays the Number of Extended Battery Modules Configured
OUTPUT LOAD	= XXX%	Displays the Output Load as a Percentage of Maximum Load
OUTPUT CURRENT	= X.XA	Displays the Output Current
OUTPUT WATT	= XXXXXW	Displays the Output Wattage
OUTPUT VA	= XXXXXVA	Displays the Output VA
UPS TEMPERATURE	= XX°C / XXX°F	Displays the Approximate Internal UPS Temperature in both °C (Celsius) and °F (Fahrenheit)
SBM STAGE	= XXXXX XH(M)	Displays the stage of Smart Battery Management with Operation Time
LOAD ENERGY	XXXX.XKWh	Display UPS Load Energy Consumption

USING THE UPS SYSTEM CONT.

(2) CONTROLS

There are 7 UPS items that can be controlled by the user.

1. Press the “UP” and “DOWN” buttons to select the “CONTROLS” ICON.
2. Press the “ENTER” button to enter the “CONTROLS” function.
3. Press the “UP” and “DOWN” buttons to scroll to the “CONTROLS” option.
4. Press the “ENTER” button to select the “CONTROLS” submenu items shown in the table below.
5. Press the “ENTER” button to select the setting you want to set up.
6. The present SET UP parameter will be displayed by Blue Color with a select mark in the front of setting parameters.
7. Press the “UP” and “DOWN” buttons to scroll through the different control functions.
8. Press the “ENTER” button to select the parameter you want to set.
9. You may be prompted “Activate?” to act the selection, if so press the “ENTER” button to act the control function. Some options are started automatically. (See the following table and screen for additional details.)
10. Press the “ESC” button to cancel or return to the previous SET UP menu.

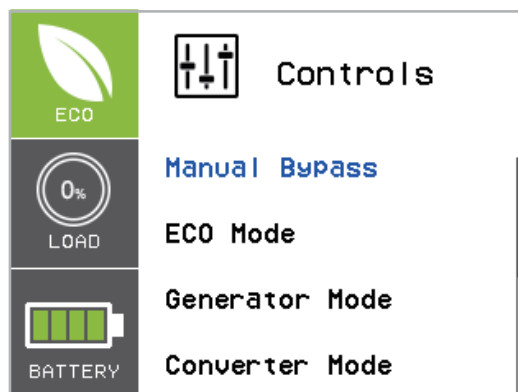

USING THE UPS SYSTEM CONT.

(2) CONTROLS CONT.

CONTROL ITEMS	AVAILABLE SETTINGS	DEFAULT SETTING
Manual Bypass	[Disable] [Enable]	Disable
	When performing UPS maintenance, the user can manually transfer the connected load to Bypass without interrupting the output to the connected equipment.	
ECO Mode*	[Disable] [Enable]	Disable
	[Voltage= +/-15%] [Voltage = +/-10%] (for [Enable])	V Range= +/-10%
	When ECO mode is enabled the UPS will check the following specifications of Bypass quality (1)Bypass voltage is inside the [V Range= +/-10%] (default setting) or [V Range= +/-15%]. (2)Bypass frequency is inside the +/-3Hz range of output nominal frequency.	
Generator Mode**	[Disable] [Enable]	Disable
	When the UPS input power source is a generator set the UPS will operate normally without transferring to Battery Mode when this is [Enable].	
Converter Mode***	[Disable] [Enable]	Converter OFF
	[Output Freq = 50Hz] [[Output Freq = 60Hz] (for [Enable]) Sets [Output Freq = 50Hz] [[Output Freq = 60Hz] to convert the input frequency to required output frequency.	
Outlet Group	[Non-Crit On] [Non-Crit Off]	Outlet On
	Sets Non-Critical Load (NCL) [Outlet On] or [Outlet Off] directly. When the user sets NCL [Outlet Off], the NCL output power will turn off directly.	
Reset Load Energy	[Reset]	None
	Reset Load Energy Consumption (KWH) value.	
Reset ReplaceBAT	[Reset]	None
	Manually reset the Battery Replacement date.	

*This function can't be set when Manual Bypass, Generator Mode or Converter Mode is enabled.

**UPS has no bypass when Generator Mode is enabled.

***UPS has no bypass when Converter Mode is enabled. This function can only be set before the UPS is on.

USING THE UPS SYSTEM CONT.

(3) SET UP

There are 28 UPS items that can be Set Up by the user.

1. Press the “UP” and “DOWN” buttons to select the “SET UP” ICON.
2. Press the “ENTER” button to enter the “SET UP” function.
3. Press the “UP” and “DOWN” buttons to scroll to the “SET UP” option.
4. Press the “ENTER” button to select the “SET UP” submenu items shown in the table below.
5. Press the “ENTER” button to select the setting you want to set up.
6. The present SET UP parameter will be displayed by Blue Color with a select mark in the front of setting parameters.
7. Press the “UP” and “DOWN” buttons to scroll through the different parameters.
8. Press the “ENTER” button to select the parameter you want to set.
9. You may be prompted “Save Change?” to save the selection, if so press the “ENTER” button to save the setting. Some options are saved and started automatically. (See the following table and screen for additional details.)
10. Press the “ESC” button to cancel or return to the previous SET UP menu.

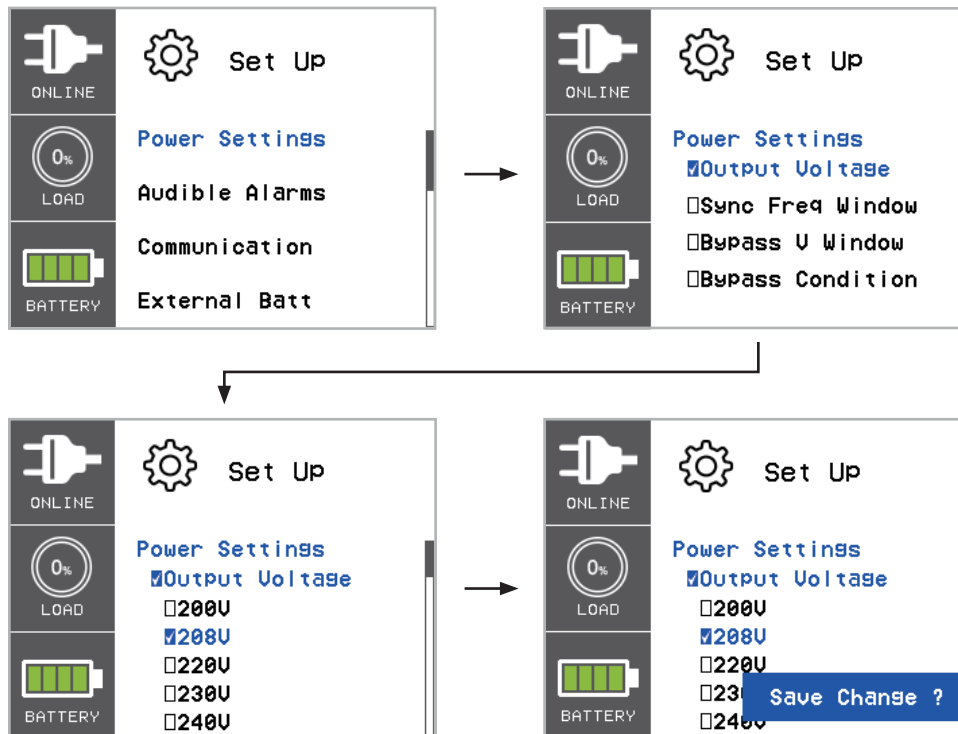

USING THE UPS SYSTEM CONT.

(3) SET UP CONT.

SET UP ITEMS		AVAILABLE SETTINGS	DEFAULT SETTING
POWER SETTING	Output Voltage	[200V][208V] [220V] [230V] [240V] Sets UPS output voltage	220V (EU) 240V (AU)
	Sync Freq Window	Range= [+/- 1%] [+/- 2%] [+/- 3%] [+/- 4%] [+/- 5%][+/- 6%] [+/- 7%] [+/- 8%] [+/- 9%] [+/-10%] Sets output synchronization frequency range If input line frequency is outside this range, the UPS will lock in at the nominal frequency.	+/- 5%
	Bypass Volt Window	Range= [+10%/-10%] [+10%/-15%] [+10%/-20%] [+15%/-10%] [+15%/-15%] [+15%/-20%] Sets Bypass Voltage range	+10%/-15%
	Bypass Condition	[Check Freq/Volt] [Check Volt Only] [No Bypass] Bypass Condition: The default setting [Check Freq/Volt] means the UPS will check the the following specifications (1) and (2) when UPS has fault and needs transfer to Bypass. The setting [Check Volt Only] means the UPS will check the the following specification (1) when UPS has fault and needs transfer to Bypass. (1)Bypass voltage is inside the range of "Bypass V Window". (2)Bypass frequency is inside the range of "Sync Freq Range". The setting [No Bypass] means the UPS is forbidden to transfer to Bypass when UPS has fault.	Check Freq/Volt
Audible Alarms		[Disable] [Enable] User can [Disable] or [Enable] the buzzer sound.	Enable
Communication	IP Address	[Mode:DHCP] [Mode:Manual]	Mode: DHCP
		[IP Address] [Subnet Mask] [Gateway] (for [Mode:Manual]) Select [Mode:Manual] to set [IP Address] [Subnet Mask] [Gateway] to network interface (RMCARD) or select DHCP to set automatically	None

USING THE UPS SYSTEM CONT.

(3) SET UP CONT.

SET UP ITEMS		AVAILABLE SETTINGS	DEFAULT SETTING
Communication	Signal Inputs	<p>[Disable] [EPO] [ROO] [Manual Bypass]</p> <p>Sets [EPO] (Emergency Power Off) to shutdown the UPS remotely when the contact is open.</p> <p>Sets [ROO] (Remote On/Off) to turn On the UPS remotely when the contact is close and turn Off the UPS remotely when the contact is open. The On/Off power button on front panel will be disabled when set to [ROO].</p> <p>Sets [Manual Bypass] if MBP(option) is installed with UPS. Please refer to the MBP User Manual.</p>	Disable
	Comm Setting	<p>[Disable] [Enable]</p> <p>All communication ports on the UPS are [Disable] or [Enable].</p>	Enable
External Batt	Auto	If UPS has EQM function, the UPS will Auto detect the external batt number.	None
	Manual	<p>= [0] [1] [2] [3] [4] [5] [6] [7] [8] [9] [10]</p> <p>Sets the actual EBM (extended battery modules) number to get the correct estimated runtime.</p>	0
Charger Function		<p>[SBM] [Constant]</p> <p>Sets [SBM] to activate the Smart Battery Management to charge the batteries.</p> <p>Sets [Constant] to use trickle charge method to charge the batteries.</p>	SBM
Charger Check		<p>[Disable] [Enable]</p> <p>Sets [Disable] or [Enable] to constantly monitor the charger function.</p>	Disable
Wiring Fault		<p>[Disable] [Enable]</p> <p>Sets [Disable] or [Enable] the auto checking of Input wiring fault.</p>	Disable
Button OFF LOCK		<p>[Disable] [Enable]</p> <p>When [Enable] is set the Power ON/OFF Button is locked and will not function to prevent accidental UPS power ON/OFF operation.</p>	Disable

USING THE UPS SYSTEM CONT.

(3) SET UP CONT.

SET UP ITEMS		AVAILABLE SETTINGS	DEFAULT SETTING
Screen Saver		[Disable] [1 Minute] [5 Minutes] Sets the amount of time the LCD screen stays on after no user input. The [Disable] option keeps the LCD screen on at all times.	5 Minutes
Periodical Batt Test		[SBM Cycle][1 week][2 weeks][3 weeks][4 weeks] Sets the Periodical Time Battery Test	SBM Cycle
Batt Install Date		----/--/-- Sets the date that the batteries were last replaced.	None
Date & Time		----/--/-- --:--:-- set Year/Month/Day Hour: Minute: Second to UPS or get Date & Time from PPBE (Agent) or RMCARD automatically.	None
With Power Cord*		[Disable] [Enable] Sets [Enable] when UPS install with Power Cord.	Disable
With Transformer		[Disable] [Enable] Sets [Enable] when UPS install with transformer.	Disable
Low Batt Capacity		[20%] [25%] [30%] [35%] [40%] [45%] [50%] [55%] [60%] [65%] When the UPS supplies battery power and the remaining capacity is lower than this threshold, the UPS will alert the software.	20%
Low Batt Runtime		[0] [1] [2] [3] [4] [5] [.....] [26] [27] [28] [29] [30] min When the UPS supplies battery power and the remaining running time is lower than this threshold, the UPS will alert the software.	0
Power Restore	Recharged Delay	[Instant] [1] [2] [3] [5] [10] [20] [30] [60] min When the utility power is restored, the UPS will start to recharge until the specified delay is expired before restoring output power.	Instant
	Recharged Capacity	[Instant] [15%] [30%] [45%] [60%] [75%] [90%] When the utility power is restored, the UPS will start to recharge until the specified battery capacity is met before restoring output power.	Instant

USING THE UPS SYSTEM CONT.

(3) SET UP CONT.

SET UP ITEMS		AVAILABLE SETTINGS	DEFAULT SETTING
NCL Bank	Turn On Delay	[Instant] [30sec] [1min] [2min] [3min] [5min] [10min] [20min] [30min] [60min] [120min] When the utility power is restored, the UPS will restore the output of this NCL outlet bank after the delay time is met.	Instant
	Turn Off Delay	[NeverOff][Instant] [30sec] [1min] [2min] [3min] [5min] [10min] [20min] [30min] [60min] [120min] When supplying battery power, the UPS will power off this NCL outlet bank after this delay time is met.	NeverOff
	Turn Off Capacity	[NeverOff] [5] [10] [15] [20] [25] [30] [35] [40] [45] [50] [55] [60] [65] [70] [75] [80] [85] [90] [95] [100] % When supplying battery power, the UPS will power off this NCL outlet bank if the remaining battery capacity is lower than this threshold.	NeverOff
	Turn Off Runtime	[NeverOff] [1] [2] [3] [4] [5] [.....] [26] [27] [28] [29] [30] min When supplying battery power, the UPS will power off this NCL outlet bank if the remaining battery runtime is lower than this threshold.	NeverOff

* Only for model OL5KRTHD/OL5KRTHDL/OL6KRTHD/OL6KRTHDL, not for model OL5KERTHDL/OL6KERTHDL.

USING THE UPS SYSTEM CONT.

(4) EVENT LOGS

The UPS will record the 12 most recent system events in the Event Log.

1. Select “EVENT LOGS” Icons
2. Press the “ENTER” button to enter the “Event Logs”.

EVENT DISPLAYED	DESCRIPTION
xx) ----/--/-- :-- Event Content	Event date and time followed by event description.
EVENT ITEM	AVAILABLE SETTINGS
Clear Event Log	[Activate?] Clears all the events stored in the LCD Control Panel Event Log.

3. Press the “UP” and “DOWN” buttons to scroll through the “Event Logs”. The UPS will record events listed in the table below. (See the reference screen with No Event.)
4. If you want to clear the present Event logs data, press the “UP” and “DOWN” buttons to scroll to the “Clear Event Logs” Option then press the “Enter” button.
5. You may be prompted “Activate?” to act the selection, if so press the “ENTER” button to act the Clear Event Logs function.
6. Press the “ESC” button to return to the Main Menu.

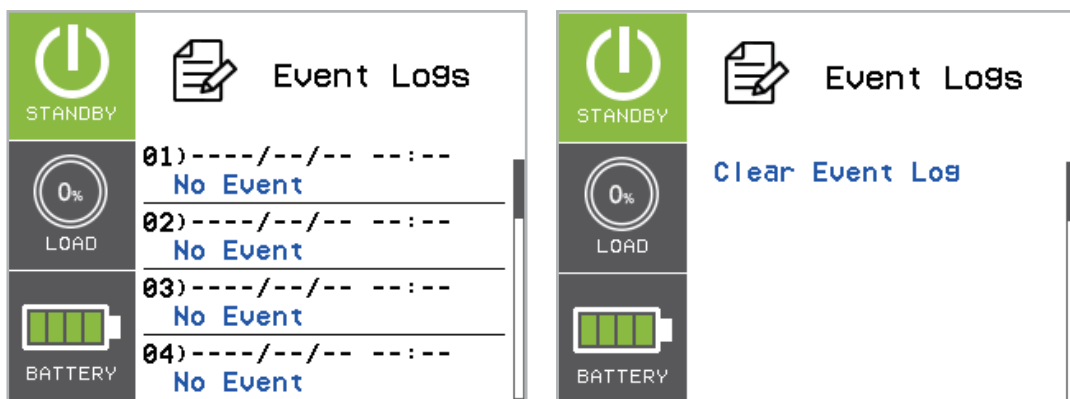

USING THE UPS SYSTEM CONT.

(4) EVENT LOGS CONT.

EVENT CONTENT	DESCRIPTION
High Output Voltage	The UPS has detected Inverter voltage too High.
Low Output Voltage	The UPS has detected Inverter voltage too Low.
Output short	The UPS has detected output short.
Bus Fault	The UPS has detected DC Bus too High or Low.
Over Temperature	The UPS has detected internal temperature too High.
Wiring Fault	The UPS has detected the input line/ neutral wire are reversed or without ground wire.
Output Overload	The UPS has detected Output Watt or VA are too High.
Over Charge	The Battery has been charged too High voltage.
Charger Failure	The Battery Charger has malfunctioned.
Battery Low	The Battery has been discharged to low level.
Load Over Set%	The UPS has detected Output Watt or VA has exceeded user set parameter.
Service Battery	The Battery Replacement Date has reached the maintenance period.
Battery Failure	The UPS has detected battery failure.
Line Abnormal	The UPS has detected the utility is out of range when the UPS is running auto-restart process.
Fan Error	The UPS has detected a fan malfunction.
BAT Disconnected	The UPS has not detected batteries.
Bypass Forbidden	User cannot use Manual Bypass function when Generator Mode or Converter Mode is enabled
Ready ON	The UPS has been turned on.
Battery Test	The Batteries have been tested.

USING THE UPS SYSTEM CONT.

(5) ABOUT

There are 11 UPS About items that can be tested by the user.

1. Select “ABOUT” Icons
2. Press the “ENTER” button to enter the “ABOUT”.
3. Press the “UP” and “DOWN” buttons to scroll through the “ABOUT” items shown in the table below.
4. Press the “ESC” button to return to the Main Menu.

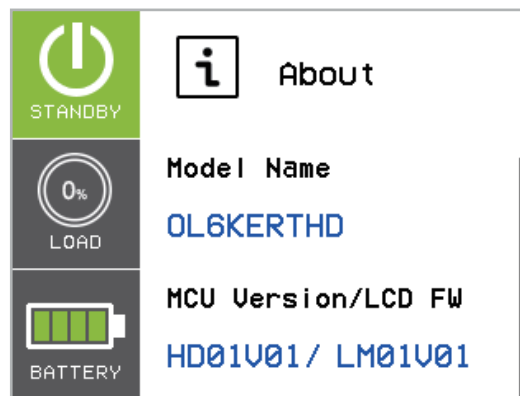

ABOUT ITEMS	DATA DISPLAYED	DESCRIPTION
Model Name		Displays the UPS Model Name
MCU Version/LCD FW	XXXXX/XXXXX	Displays the UPS MCU and LCD Firmware Version
UPS Rating	XXXXVA/XXXXW	Displays the UPS Rating
Date and Time	----/--/-- --:--	Displays the present Date & Time
IP	XXXXXX	Display the network IP address
	XXX.XXX.XXX.XXX	
Subnet Mask	XXX.XXX.XXX.XXX	Display the network Subnet Mask
Gateway	XXX.XXX.XXX.XXX	Display the network Gateway
MAC	XX-XX-XX-XX-XX-XX	Display the network card MAC address
Next BATT Change	XXX / XXXX	Displays the next Battery Change Date & Time
Last BATT Test Date	XXXX/XX/XX	Displays the Last Battery Test Date & Time
EQM	Battery Status : XXX Volt : XX.XX ~ XX.XXV Temp(°C) : XX.X ~ XX.X Equalization : XXXXXX	Displays the UPS or External BATT EQM information

USING THE UPS SYSTEM CONT.

(6) DIAGNOSTICS

There are 4 UPS Diagnostic items that can be tested by the user.

1. Select “DIAGNOSTICS” Icons
2. Press the “ENTER” button to enter the “DIAGNOSTICS”.
3. Press the “UP” and “DOWN” buttons to scroll through the “DIAGNOSTICS” items shown in the table below.
4. You may be prompted “Activate?” to act the selection, if so press the “ENTER” button to act the test function and the test will start automatically.
5. Press the “ESC” button to return to the Main Menu.

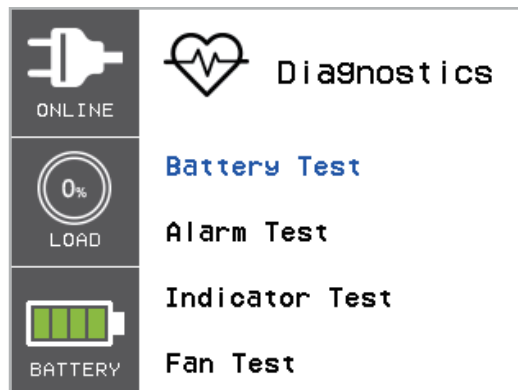



ITEMS	AVAILABLE SETTINGS	DESCRIPTION	
DIAGNOSTIC	Battery Test*	Activate?	Starts a manual battery test, UPS will operate 10 seconds on Battery mode to check battery condition.
	Alarm Test		Starts a manual Alarm test, buzzer will sound for 5 seconds.
	Indicator Test		Starts a manual Indicator test, UPS will change LCD color display to Yellow/Blue/Green and initialize the screen to WELCOM page then back to Main Menu.
	Fan Test		Starts a manual Fan test, UPS will operate fan with full speed 5 seconds.

*The Battery Test may not perform if the UPS condition did not match the testing condition.





USING THE UPS SYSTEM CONT.

TROUBLESHOOTING

LCD will use RED or Yellow color to indicate the Fault or warning status and also connect the color frame with ICON which has the same color and locates on the left zone of the screen.

WARNING	ICON	POSSIBLE CAUSE	SOLUTION
Battery Mode		UPS is operating on battery power.	Save your data and perform a controlled- shutdown.
Load Over XXX%		Your equipment requires more power than the setting in the Power Management Software (Power Panel® Business) will allow.	Shut off the non-essential equipment or increase the level in the Power Management Software.
Wiring Fault*		Line and neutral wires are reversed.	Exchange line and neutral wires.
*Only applicable in areas where 200-240 V electrical service is provisioned with a Neutral line.		Missing ground wire.	Connect ground wire.
		No ground wire.	Disable Wiring Fault alarm on LCD panel.
Line Abnormal		Utility power is out of range for the UPS to auto-restart.	Check whether voltage or frequency of utility power is out of range.
Over Charge		Battery is overcharged.	Remove battery connector and check charger voltage.
Service Battery		The Battery Replacement Date has reached the recommended 3 year maintenance period.	If batteries have been recently replaced, then reset the Battery Replacement Date using PowerPanel® Business Edition-Agent software, RMCARD interface or through the LCD control panel on the UPS (See LCD Setting Configuration).

USING THE UPS SYSTEM CONT.

WARNING	ICON	POSSIBLE CAUSE	SOLUTION
Output Overload		Your equipment requires more power than the UPS can provide. If the UPS is in Line Mode then it will transfer to Bypass Mode; if the UPS is in Battery Mode it will shutdown.	Shut off non-essential equipment. If this solves the overload problem, the UPS will transfer to normal operation.
Battery Low		UPS is operating on battery power and will be shutting down soon due to extremely low battery voltage.	UPS will restart automatically when acceptable utility power returns.
BAT Disconnected		Missing battery power.	Check battery connector and battery breaker.
Battery Failure		UPS has failed in Battery Test.	Check battery connector and battery breaker. Contact technical support to replace the battery.
Output Short		Output short circuit.	Your attached equipment may have problems, please remove them and check again.
Over Temperature		High temperature sensor activates protection.	Check the fan for operation and if the ventilation hole has been covered.
Bypass Forbidden		Manual Bypass Forbidden when the LCD screen shows "Generator On" or "Converter On".	Slide the Interlock Bracket to the right. (For the Maintenance Bypass Module only)
EPO OFF	N/A	Missing the EPO connection.	Check the EPO connection.
Cold start Lock		UPS is locked to prevent consuming battery power during shipping.	Connect UPS to utility power for first-time operation.
Auto restart Lock		"Automatic Restore" is disabled in Power Management Software (PowerPanel® Business)	Press "ON/OFF" button to turn on UPS or let the UPS auto restart by setting "Automatic Restore" to Enable via Power Management Software (PowerPanel® Business). Or RMCARD.

USING THE UPS SYSTEM CONT.

FAULT	ICON	POSSIBLE CAUSE	SOLUTION
Charger Failure		Charger has failed.	Contact CyberPower for assistance.
High Output V		Output voltage is too high.	Shut down UPS and turn off input breaker.
Low Output V		Output voltage is too low.	
Bus Fault		Internal DC bus voltage is too high or too low.	Contact CyberPower for assistance.
Fan Error		Internal Fan has failed.	Perform a Fan Test and check the Alarm. If the Alarm continues, Shut down UPS and turn off input breaker. Contact CyberPower for assistance.

MAINTENANCE

Storage

To store your UPS for an extended period of time, cover and store it with the battery fully charged. Recharge the battery every three months to ensure battery life.

Battery Replacement

Please read and follow the Safety Instructions before servicing the battery. Battery replacement should be performed by trained personnel who are familiar with the procedures and safety precautions. Make a note of the Replacement Battery part number.

Safety Precautions



Warning: High voltage – Risk of Electric Shock

Only use replacement batteries that are certified by Cyber Power Systems. Use of incorrect battery type is an electrical hazard that could lead to explosion, fire, electric shock, or short circuit.

Batteries contain an electrical charge that can cause severe burns. Before servicing batteries, please remove any conductive materials such as jewelry, chains, wrist watches, and rings.

Do not open or mutilate the batteries. Electrolyte fluid is harmful to the skin/eyes and may be toxic.

To avoid electric shock, turn off and unplug the UPS from the wall receptacle before servicing the battery.

Only use tools with insulated handles. Do not lay tools or metal parts on top of the UPS or battery terminals.

Replacement Batteries

Please refer to the front side of the EBM for the model number of the correct replacement batteries. For battery procurement, go to www.CyberPower.com, or contact your local dealer.

When the Replace Battery the LCD displays Service Battery, use PowerPanel® Business Edition Agent software or log on to the RMCARD to perform a runtime calibration to verify battery capacity is sufficient and acceptable.

Battery Disposal



Do Not Discard

Batteries are considered hazardous waste and must be disposed of properly. Contact your local government for more information about proper disposal and recycling of batteries. Do not dispose of batteries in fire.

Cyber Power Systems encourages environmentally sound methods for disposal and recycling of its UPS products.

Please dispose and/or recycle your UPS and batteries in accordance with local regulations.

MAINTENANCE CONT.

Battery Disposal Cont.

Cyber Power Systems encourages environmentally sound methods for disposal and recycling of its UPS products.

Please dispose and/or recycle your UPS and batteries in accordance with local regulations.

BATTERY REPLACEMENT

Step 1: Unscrew and push the front panel to right side to remove it.

Step 2: Unscrew and open the battery access door. This screw is designed to be fixed on the door, do not remove it from the metal cover.

Step 3: Disconnect the internal battery connector and battery management module connector.

Step 4: Unscrew the thumbscrew on the battery retention bracket and then remove it.

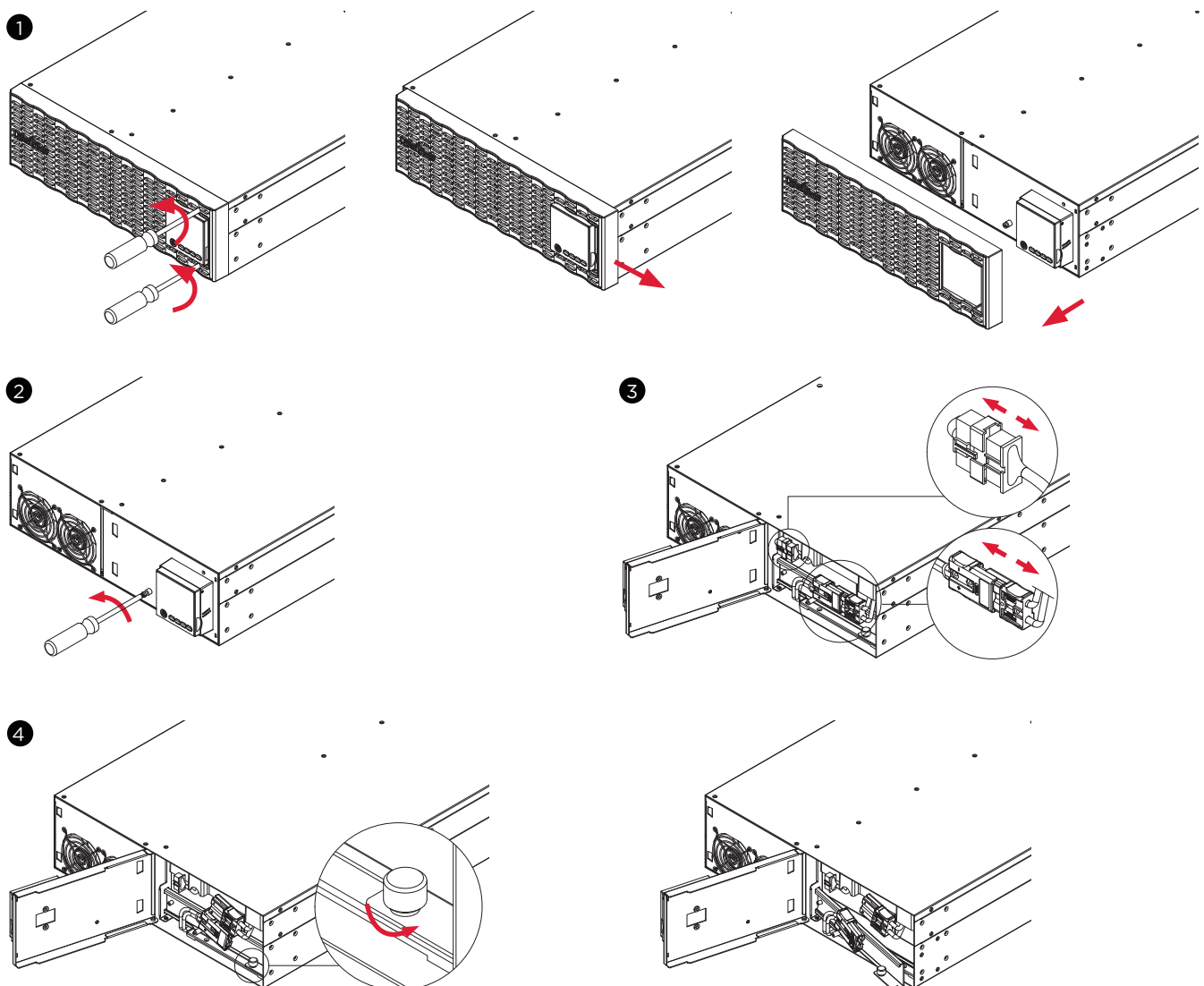

MAINTENANCE CONT.

BATTERY REPLACEMENT CONT.

Step 5: Pull the battery trays out slowly and then put the new battery trays into the compartment.

Step 6 : Assemble the battery retention bracket and tighten the thumbscrew.

Step 7: Connect the internal battery connector and battery management module connector. Ensure that they are seated properly (connector will click into place).

Step 8: Tighten the screw on the battery access door and install the front panel back. Push the front panel to left side. Tighten the screws on the front panel.

Step 9: Execute a battery test via the LCD control panel. To do this go to the Main Menu and select the Diagnostics Icon, then select Battery Test and Activate. After Battery test, go back to the Main Menu then select the Set UP icon, then select Batt Install Date to set the battery installation date. This operation can also be done via PowerPanel® Business or the RMCARD web interface. Please see their respective User Manuals for detailed instructions.

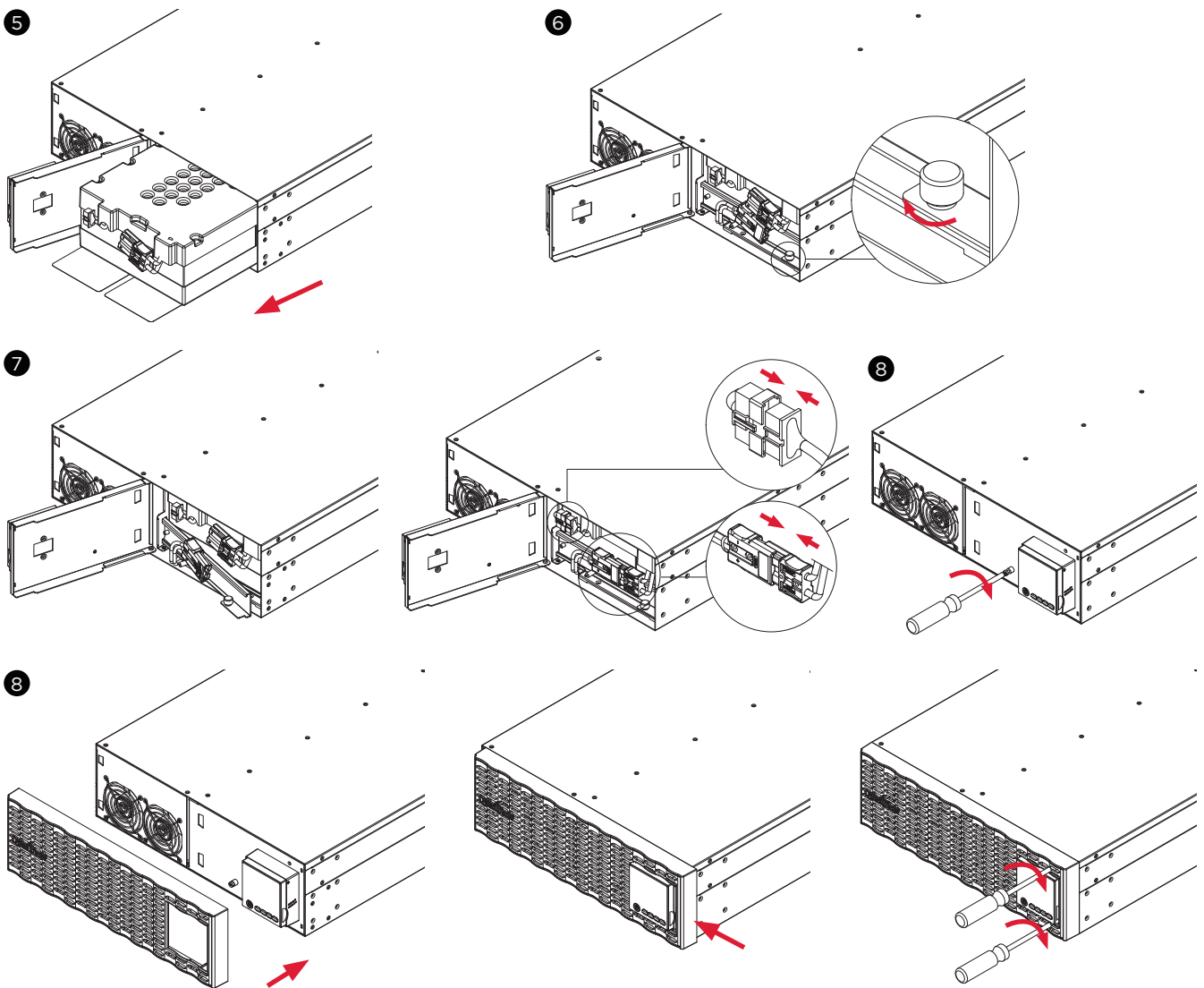

TECHNICAL SPECIFICATIONS

MODELS	OL5KERTHDL	OL6KERTHDL
CONFIGURATION		
Capacity (VA)	5000 VA	6000 VA
Capacity (Watts)	5000 W	6000 W
Form Factor	Rackmount/Tower	
Energy-saving Technology	ECO Mode Efficiency \geq 96%	
INPUT		
Input Voltage Range	120-139Vac for 0-25% Load 140-159Vac for 0-50% Load 160-179Vac for 0-75% Load 180-280Vac for 0-100% Load	
Input Frequency Range	40-70 Hz (Auto-Sensing)	
Input Power Factor	0.99	
Cold Start	Yes	
OUTPUT		
Output Waveform	Sine wave	
Output Voltage	200, 208, 220, 230, 240 V \pm 2% (Configurable)	
Output Frequency	50/60 Hz \pm 0.25 Hz (Auto-Sensing or Configurable)	
Transfer Time (Typical)	0ms	
Rated Power Factor	1	
Harmonic Distortion	THD < 3% at Linear Load, < 5% at Non-linear Load	
Crest Factor	3 : 1	
ECO Mode Bypass Voltage Range	\pm 10%, \pm 15% (Configurable)	
UPS Outlets	(2) IEC C19, (4) IEC C13, (1) Hardwire Terminal Block	
PROTECTION		
Surge Protection	IEC 61000-4-5 Level 3 (2430 Joules)	
Overload Protection	Line Mode: 105-125% Load for 1 min, 126-150% Load for 10 sec Battery Mode: 105-130% Load for 10 sec, 131-150% Load for 2 sec	
Short Circuit Protection	UPS Output Cut off Immediately or Input Fuse / Circuit Breaker Protection	

TECHNICAL SPECIFICATIONS CONT.

MODELS	OL5KERTHDL	OL6KERTHDL
BATTERY		
Specifications	(12) 12 V/9 Ah	
Recharge Time 0-90% (Typical)	4 hours	
Sealed, Maintenance Free	Yes	
Hot-Swappable	Yes	
STATUS INDICATORS		
LCD Screen	Multi-Function Color TFT-LCD Readout that Supports: (15) Types of UPS status, (7) Types of Controls, (28) Types of Set Up, (12) Event Logs, (11) Types of About, (4) Types of Diagnostics	
Audible Alarms	Battery Mode, Battery Low, Overload, UPS Fault	
MANAGEMENT & COMMUNICATIONS		
On-Device Features	Start-up Self Test, Auto-Charge, Auto-Restart, Auto-Overload Recovery	
Connectivity Ports	(1) Serial Port (RS232), (1) USB Port	
SNMP/HTTP Capable	(1) Remote management card is pre-installed in expansion slot	
ENVIRONMENT		
Operating Temperature	32°F to 104°F (0°C to 40°C)	
Operating Relative Humidity	0 to 90% Non-Condensing	
SOFTWARE		
Power Management Software	PowerPanel® Business Edition	
PHYSICAL		
Dimension	L x W x H = 28.3 x 17 x 5.1 in. (72.0 x 43.3 x 13.0 cm)	
Net Weight	115.2 lbs (52.3 kg)	
SAFETY		
Conformance Approvals	CE, RCM, EAC	
RoHS	RoHS Compliant	

TROUBLESHOOTING

PROBLEM	POSSIBLE CAUSE	SOLUTION
WARNING		
O/P Overload	Your equipment requires more power than the UPS can provide. If the UPS is in Line Mode then it will transfer to Bypass Mode; if the UPS is in Battery Mode it will shut down.	Shut off non-essential equipment. If this solves the overload problem, the UPS will transfer to normal operation.
Load Over XXX%	Your equipment requires more power than the setting in the Power Management Software (PowerPanel® Business) will allow.	Shut off the non-essential equipment or increase the level in the Power Management Software.
Battery Mode	UPS is operating on battery power.	Save your data and perform a controlled shutdown.
Battery Low	UPS is operating on battery power and will be shutting down soon due to extremely low battery voltage.	UPS will restart automatically when acceptable utility power returns.
BAT Disconnected	No battery power is being detected by the UPS.	Check the battery connector and the battery breaker.
Battery Failure	UPS has failed a Battery Test.	Check the battery connector and the battery breaker. Contact technical support to replace the battery.
Replace Battery	Battery will need to be replaced soon due to insufficient runtime.	Install new batteries, execute battery test, and reset the replace battery date.
Service Battery	The Battery Replacement Date has reached the recommended 3 year maintenance period.	Perform a runtime calibration to verify battery capacity is sufficient and acceptable. If batteries have been recently replaced, then reset the Battery Replacement Date using PowerPanel® Business Edition Agent software, RMCARD web interface or through the LCD control panel on the UPS (See LCD Configuration Settings).
EPO OFF	Missing the EPO connection.	Check the EPO connection.
Wiring Fault* *Only applicable in areas where 200-240 V electrical service is provisioned with a Neutral line.	Line and neutral wires are reversed.	Exchange line and neutral wires.
	Missing ground wire.	Connect ground wire.
	No ground wire.	Disable Wiring Fault alarm on LCD control panel.

TROUBLESHOOTING CONT.

PROBLEM	POSSIBLE CAUSE	SOLUTION
WARNING		
Line Abnormal	Utility power is out of range for the UPS to auto-restart.	Check whether voltage or frequency of input power is out of range.
Output Short	Output short circuit.	The connected equipment may have problems, please remove them and check again.
Over Temperature	High temperature sensor activated protection.	Check the fan for operation and verify that ventilation is not obstructed.
Cold start Lock	UPS is locked to prevent consuming battery power during shipping.	Connect UPS to utility power for first-time operation.
Auto restart Lock	“Automatic Restore” is disabled in Power Management Software (PowerPanel® Business Edition)	Press “ON/OFF” button to turn UPS on.
Bypass Forbidden	Manual Bypass Forbidden when the LCD screen shows “Generator On” or “Converter On”.	Slide the Interlock Bracket to the right. (Only for UPS models with a Maintenance Bypass Module)
FAULT		
Over Charge	Battery is overcharged.	Remove battery connector and check charger voltage. Contact CyberPower for assistance.
Charger Failure	Charger has failed.	
High O/P V	Output voltage is too high.	Shut down UPS and turn off input breaker. Contact CyberPower for assistance.
Low O/P V	Output voltage is too low.	
Bus Fault	Internal DC bus voltage is too high or too low.	

CyberPower

Cyber Power Systems, Inc. | www.cyberpower.com

Copyright © 2024 Cyber Power Systems, Inc. All rights reserved.

CyberPower and the CyberPower logo are trademarks of Cyber Power Systems, Inc., and/or affiliates, which are registered in many countries and regions. All other trademarks are the property of their respective owners.