

DE'LONGHI

COOKING

INSTALLATION & USER INSTRUCTIONS

DSR .. IND..
VITROCERAMIC COOKER
(INDUCTION HOB)



CONTENTS	Page Number
Introduction	3
Important Safeguards & Recommendations	4 - 10
Advice for the installer	11
Installation	12 - 15
Electrical installation	16 - 18
Advice for the Users.....	20
Cooking Hob	21
Control Panel	22
Use of induction hob	23 - 34
Multifunction oven	35 - 40
Cooking guide	41
Electronic clock "Touch-control"	42 - 46
Cleaning & maintenance	47 - 55
Guarantee & After Sales Service	56

Dear Customer,

Thank you for purchasing the DeLonghi DSR .. IND.. vitroceramic cooker (induction hob).

The safety precautions and recommendations listed below are for your own safety and that of others. They will also provide a means by which to make full use of the features offered by your appliance.

Please retain this booklet for future reference.

This appliance must be used only for the task it has explicitly been designed for, that is for cooking foodstuffs. Any other form of usage is to be considered as inappropriate and therefore potentially dangerous.

The manufacturer declines all responsibility in the event of damage caused by improper, incorrect or illogical use of the appliance.

DECLARATION OF CE CONFORMITY

- This appliance has been designed to be used only for cooking. Any other use (such as heating a room) is improper and dangerous.
- This appliance has been designed, constructed, and marketed in compliance with:
 - Safety requirements of the "Low voltage" Directive 2014/35/EU;
 - Safety requirements of the "EMC" Directive 2014/30/EU;
 - Requirements of EU Directive 93/68/EEC;
 - Requirements of EU Directive 2011/65/EU.



IMPORTANT INFORMATION FOR CORRECT DISPOSAL OF THE PRODUCT IN ACCORDANCE WITH EC DIRECTIVE 2012/19/EC.

At the end of its working life, the product must not be disposed of as urban waste. It must be taken to a special local authority differentiated waste collection centre or to a dealer providing this service.

Disposing of a household appliance separately avoids possible negative consequences for the environment and health deriving from inappropriate disposal and enables the constituent materials to be recovered to obtain significant savings in energy and resources. As a reminder of the need to dispose of household appliances separately, the product is marked with a crossed-out wheeled dustbin.



IMPORTANT SAFETY PRECAUTIONS AND RECOMMENDATIONS

IMPORTANT: This appliance is designed and manufactured solely for the cooking of domestic (household) food and is not suitable for any non domestic application and therefore should not be used in a commercial environment.

The appliance guarantee will be void if the appliance is used within a non domestic environment i.e. a semi commercial, commercial or communal environment.

Read the instructions carefully before installing and using the appliance.

- This appliance has been designed and manufactured in compliance with the applicable standards for the household cooking products and it fulfills all the safety requirements shown in this manual, including those for surface temperatures. Some people with sensitive skin may have a more pronounced temperature perception with some components although these parts are within the limits allowed by the norms. The complete safety of the appliance also depends on the correct use, we therefore recommend to always pay a extreme attention while using the product, especially in the presence of children.
- After having unpacked the appliance, check to ensure that it is not damaged and that the oven door closes correctly. In case of doubt, do not use it and consult your supplier or a professionally qualified technician.
- Packing elements (i.e. plastic bags, polystyrene foam, nails, packing straps, etc.) should not be left around within easy reach of children, as these may cause serious injuries.
- Some appliances are supplied with a protective film on steel and aluminum parts. **This film must be removed before using the appliance.**
- **IMPORTANT:** The use of suitable protective clothing/gloves is recommended when handling or cleaning this appliance.

- Do not attempt to modify the technical characteristics of the appliance as this may become dangerous to use. The manufacturer declines all responsibility for any inconvenience resulting from the inobservance of this condition.
- CAUTION: this appliance must only be installed in a permanently ventilated room in compliance with the applicable regulations.
- Do not operate your appliance by means of an external timer or separate remote-control system.
- Do not carry out cleaning or maintenance operations on the appliance without having previously disconnected it from the electric power supply.
- WARNING: Ensure that the appliance is switched off before replacing the oven lamp to avoid the possibility of electric shock.
- Do not use a steam cleaner because the moisture can get into the appliance therefore making it unsafe.
- Do not touch the appliance with wet or damp hands (or feet).
- Do not use the appliance whilst in bare feet.
- If you should decide not to use this appliance any longer (or decide to substitute another model), before disposing of it, it is recommended that it be made inoperative in an appropriate manner in accordance to health and environmental protection regulations, ensuring in particular that all potentially hazardous parts be made harmless, especially in relation to children who could play with unused appliances.
- The various components of the appliance are recyclable. Dispose of them in accordance with the regulations in force in your country. If the appliance is to be scrapped, remove the power cord.
- After use, ensure that the knobs are in the off position.
- Children less than 8 years of age shall be kept away unless continuously supervised.
- This appliance can be used by children aged from 8 years and above and persons with reduced physical, sensory or mental capabilities or lack of experience and knowledge if they have been given supervision or instruction concerning use of the appliance in a safe way and understand the hazards involved.

- Children shall not play with the appliance. Cleaning and user maintenance shall not be made by children without supervision.
- The manufacturer declines all liability for injury to persons or damage to property caused by incorrect or improper use of the appliance.
- **WARNING:** During use the appliance and its accessible parts become hot; they remain hot for some time after use.
 - Care should be taken to avoid touching heating elements (on the hob and inside the oven).
 - The door is hot, use the handle.
 - To avoid burns and scalds, young children should be kept away.
- Make sure that electrical cables connecting other appliances in the proximity of the cooker cannot come into contact with the hob or become entrapped in the oven door.
- **WARNING:** Unattended cooking on a hob with fat or oil can be dangerous and may result in fire. **NEVER** try to extinguish a fire with water, but switch off the appliance and then cover flame e.g. with a lid or a fire blanket.
- **WARNING:** Danger of fire: do not store items on the cooking surfaces.
- Do not place or leave empty pans on the glass ceramic hob.
- Do not allow heavy or sharp objects to drop on the glass ceramic hob.
- Do not scratch the hob with sharp objects. Don't use the hob as a work surface.
- **WARNING:** If the hob is cracked or otherwise damaged by falling objects etc., disconnect the appliance from the electrical power supply to avoid the possibility of electric shock and call Customer Service.
- **WARNING:** When correctly installed, your product meets all safety requirements laid down for this type of product category. However special care should be taken around the rear or the underneath of the appliance as these areas are not designed or

intended to be touched and may contain sharp or rough edges, that may cause injury.

- **FIRST USE OF THE OVEN** - it is advised to follow these instructions:
 - Furnish the interior of the oven as described in the chapter “CLEANING AND MAINTENANCE”.
 - Switch on the empty oven on max to eliminate grease from the heating elements.
 - Disconnect the appliance from the electrical power supply, let the oven cool down and clean the interior of the oven with a cloth soaked in water and neutral detergent; then dry carefully.
- **CAUTION:** Do not use harsh abrasive cleaners or sharp metal scrapers to clean the oven door glass since they can scratch the surface, which may result in shattering of the glass.
- Do not line the oven walls or base with aluminum foil. Do not place baking trays or the drip tray on the base of the oven chamber.
- Do not cover the hob with aluminum foils.
- **FIRE RISK!** Do not store flammable material in the oven or in the storage compartment.
- Always use oven gloves when removing the shelves and food trays from the oven whilst hot.
- Do not hang towels, dishcloths or other items on the appliance or its handle – as this could be a fire hazard.
- Clean the oven regularly and do not allow fat or oils to build up in the oven base or tray. Remove spillages as soon as they occur.
- Do not stand on the cooker or on the open oven door.
- Always stand back from the appliance when opening the oven door to allow steam and hot air to escape before removing the food.
- **SAFE FOOD HANDLING:** Leave food in the oven for as short a time as possible before and after cooking. This is to avoid contamination by organisms which may cause food poisoning. Take particular care during warmer weather.
- **WARNING:** Take care NOT to lift the cooker by the door handle.

- **CAUTION:** The cooking process has to be supervised. A short term cooking process has to be supervised continuously.
- The appliance must not be installed behind a decorative door in order to avoid overheating.
- The oven accessories (e.g. oven wire rack) must be fitted correctly as indicated at page 49.
- **IMPORTANT NOTE:** The oven shelves (for some products one shelf only is provided) have not been designed to place the food directly on the shelf itself. When cooking, always place the food in special containers or use specific materials suitable for the food contact.
- If the power supply cable is damaged, it must be replaced only by an authorized service agent in order to avoid a hazard.
- If the appliance is not fitted with a supply cord and a plug, or with other means for disconnection from the supply mains having a contact separation in all poles that provide full disconnection under overvoltage category III conditions, means for disconnection must be incorporated in the fixed wiring in accordance with the wiring rules.
- **WARNING:** The appliance and its accessible parts become hot during use.
Care should be taken to avoid touching heating elements.
Children less than 8 years of age shall be kept away unless continuously supervised.
- **WARNING:** Use only hob guards designed by the manufacturer of the cooking appliance or indicated by the manufacturer of the appliance in the instructions for use as suitable or hob guards incorporated in the appliance. The use of inappropriate guards can cause accidents.
- **INDUCTION HOBBS:**
 - Metallic objects such as knives, forks, spoons and lids should not be placed on the hob surface since they can get hot.
 - Do not use metallic kitchen utensils (e.g. ladles). It is preferable to use plastic or wood kitchen utensils.
 - Please use pans of recommended size (see minimum pan diameter recommended). It is not advisable to use pans

smaller than the cooking zone. The pans have to be placed in the centre of the cooking zone.

- Do not use defective pans or pans with a curved bottom.
- Please use suitable pans marked for induction cooking.
- Please keep your distance from the electromagnetic fields by standing 5-10 cm from the cooking zones. When possible use the rear cooking zones.
- Magnetic objects (e.g. credit cards, floppy disks, memory cards) and electronic instruments (e.g. computers) should not be placed near the induction hob.
- The heating of magnetic tins is forbidden! Closed tins may explode by exceeding pressure while heating. There is a burning risk with open tins as well, because the integrated temperature protection will not work correctly.

ENERGY LABELLING/ECODESIGN

- Commission delegated regulation (EU) No 65/2014 (supplementing Directive 2010/30/EU of the European Parliament and of the Council).
- Commission regulation (EU) No 66/2014 (implementing Directive 2009/125/EC of the European Parliament and of the Council).

Reference to the measurement and calculation methods used to establish compliance with the above requirements:

- Standard EN 60350-1 (electric ovens).
- Standard EN 60350-2 (hobs: electric cooking zones and/or areas).

USE OF THE APPLIANCE, ENERGY SAVING TIPS

OVEN

- Check the oven door always closes properly and the door gasket is clean and in order. During use, open the oven door only when strictly necessary to avoid heat losses (for some functions it may be necessary to use the oven with the door half-closed, check the oven operating instructions).
- Turn off the oven 5-10 minutes before the end of the theoretical cooking time to recuperate the stored heat.
- We recommend using oven proof dishes and adjusting the oven temperature during cooking if necessary.

HOB

INDUCTION COOKING ZONES AND/OR AREAS

- To save electricity, use lids whenever possible.
- When the pan comes to the boil, turn the heat down to the level desired.
- Please use suitable pans marked for induction cooking. Some cookware available on the market has an effective ferromagnetic area which is much smaller than the diameter of the pan itself. Avoid using this cookware because the induction cooktop may not function properly or may be damaged.
- Always use pans/coffee pots with thick, completely flat bottom. Do not use pans/coffee pots with concave or convex bottom; these could cause overheating of the cooking zone.
- Important: Do not use pots/coffee pot adaptors.

Advice for the installer

IMPORTANT:

- The appliance is designed and approved for domestic use only and should not be installed in a commercial, semi commercial or communal environment, in Motorhomes, Caravans (except Static/Park Homes), or any boat or vessel used on the sea, estuary, lakes or inland waterways.

Your product will not be guaranteed if installed in any of the above environments and could affect any third party or public liability insurances you may have.

The appliance may be installed in a kitchen, kitchen/diner or a bed sitting room, but not in a room or space containing a bath or a shower without first consulting current regulations.

The appliance must not be installed in a bed-sitting room of less than 20 m³.

- Cooker installation must only be carried out by a **SUITABLY QUALIFIED AND REGISTERED TECHNICIAN** and in compliance with local safety standards. Failure to observe this rule will invalidate the warranty.
- The appliance must be installed in compliance with regulations in force in your country and in observation of the manufacturer's instructions.
- Incorrect installation, for which the manufacturer accepts no responsibility, may cause personal injury or damage.
- This appliance shall only be serviced by authorized personnel.
- Always disconnect the cooktop from mains power supply before carrying out any maintenance operations or repairs.
- Some appliances are supplied with a protective film on steel and aluminum parts. **This film must be removed before using the cooker.**
- **Important: The use of suitable protective clothing/gloves is recommended when handling or installing this appliance.**
- **The appliance must be housed in heat resistant units.**
- **The walls of the units must not be higher than work top and must be capable of resisting temperatures of 70 °C above room temperature.**
- **We would point out that the adhesive which bonds the plastic laminate to the furniture must withstand temperatures not less than 150 °C to avoid delamination.**
- **Do not install the appliance near inflammable materials (e.g. curtains).**

WARNING

When correctly installed, your product meets all safety requirements laid down for this type of product category.

However special care should be taken around the underneath of the appliance as this area is not designed or intended to be touched and may contain sharp or rough edges, that may cause injury.

1 - INSTALLATION

The installation conditions, concerning protection against overheating of the surfaces adjacent to the cooker, must conform to fig 1.1.

The appliance must be kept no less than 50 mm away from any side wall which exceeds the height of the hob surface (fig. 1.1).

The veneered synthetic material and the glue used must be resistant to a temperature of 150 °C in order to avoid ungluing or deformations.

Curtains must not be fitted immediately behind appliance or within 500 mm of the sides.

The appliance must be housed in heat resistant units.

The walls of the units must not be higher than work top and must be capable of resisting temperatures of 70 °C above room temperature.

Do not install the appliance near inflammable materials (e.g. curtains).

If the cooker is located on a pedestal it is necessary to provide safety measures to prevent falling out.

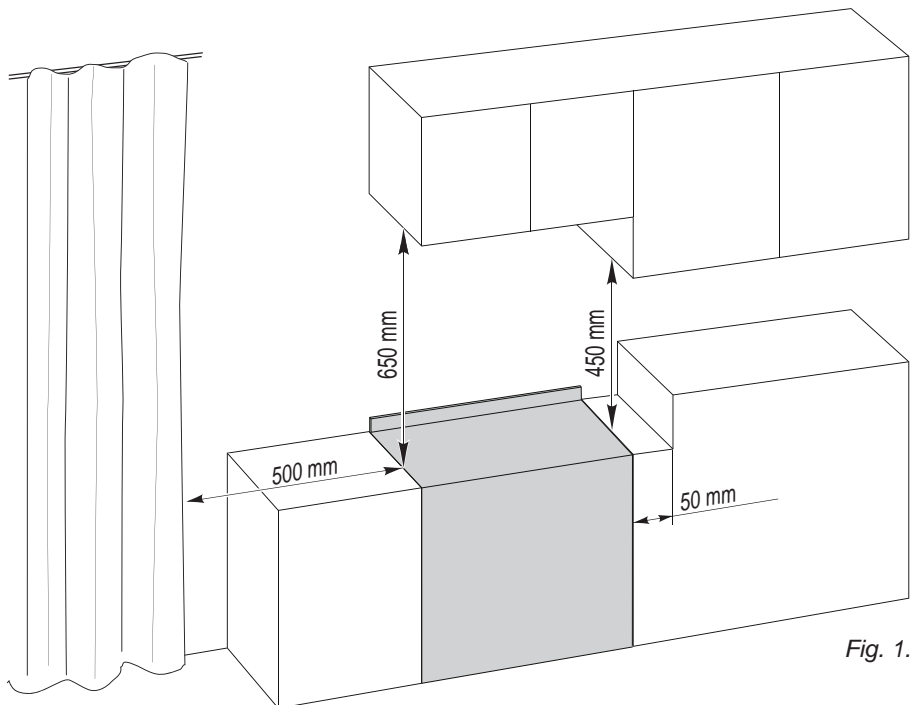

Fig. 1.1

FITTING THE ADJUSTABLE FEET

The adjustable feet must be fitted to the base of the cooker before use (fig. 1.2).

Rest the rear of the cooker on a piece of the polystyrene packaging exposing the base for the fitting of the feet.

Fit the 4 legs by screwing them tight into the support base as shown in figures 1.2,1.3

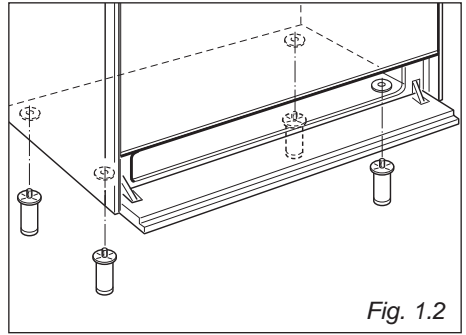

Fig. 1.2

LEVELLING THE COOKER

The cooker may be levelled by screwing the lower ends of the feet IN or OUT (fig. 1.4).

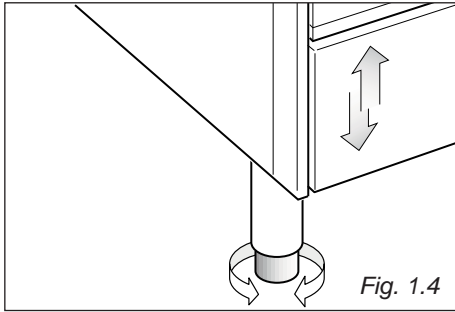

Fig. 1.4

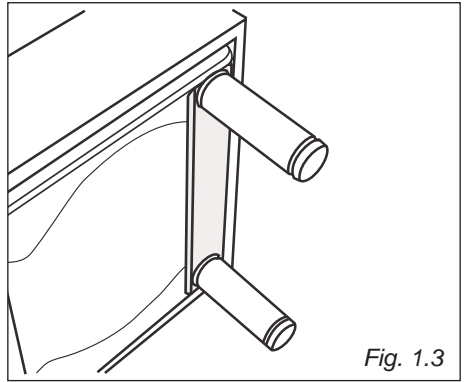

Fig. 1.3

BACKGUARD (some models only)

Before installing the cooker, assemble the backguard "C" (fig. 1.5).

Please note that :

- The backguard "C" can be found packed at the rear of the cooker.
- Before assembling remove any protective film/adhesive tape.
- Remove the two spacers "A" and the screw "B" from the rear of the cooktop.
- Assemble the backguard as shown in figure 1.5 and fix it by screwing the central screw "B" and the spacers "A".

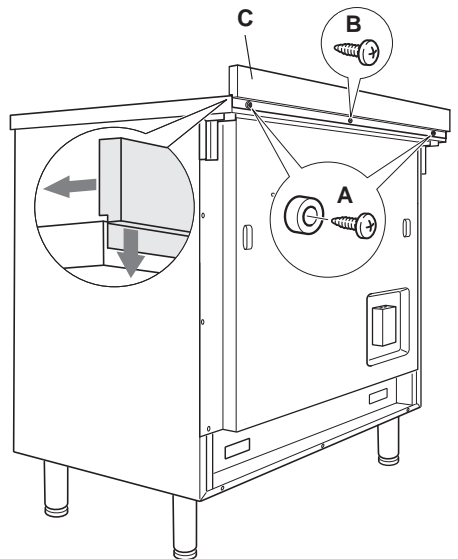

Fig. 1.5

MOVING THE COOKER

WARNING: When raising cooker to upright position always ensure two people carry out this manoeuvre to prevent damage to the adjustable feet (fig. 1.6).

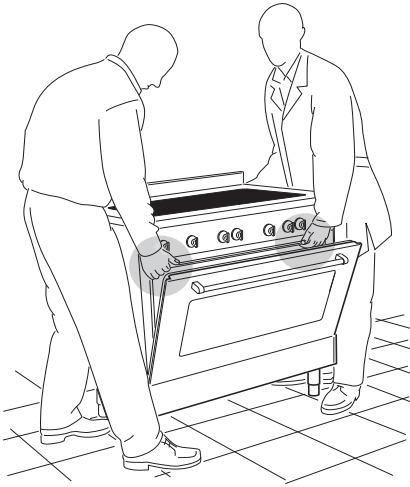

Fig. 1.6

WARNING

Be careful: **DO NOT LIFT** the cooker by the door handle when raising to the upright position (fig. 1.7).

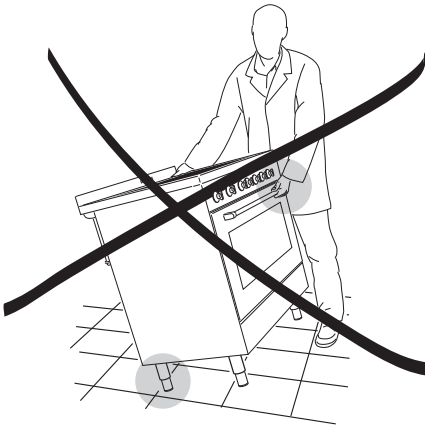

Fig. 1.7

WARNING

When moving cooker to its final position **DO NOT DRAG** (fig. 1.8).
Lift feet clear of floor (fig. 1.6).

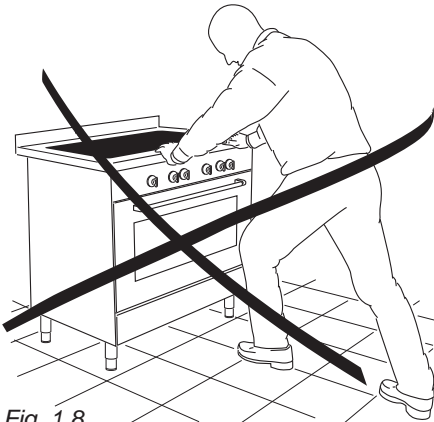

Fig. 1.8

ANTI-TILT BRACKET

Important!

To restrain the appliance and prevent it tipping accidentally, fit the supplied bracket to the rear wall to fix it securely.

To fit the anti-tilt bracket:

1. After you have located where the cooker is to be positioned, mark on the wall the place where the two screws of the anti-tilt bracket have to be fitted. Please follow the indications given in fig. 1.9.
2. Drill two 8 mm diameter holes in the wall and insert the plastic plugs supplied.

Important!

Before drilling the holes, check that you will not damage any pipes or electrical wires.

3. Loosely attach the anti-tilt bracket with the two screws supplied.
4. Move the cooker to the wall and adjust the height of the anti-tilt bracket so that it can engage in the slot on the cooker's back, as shown in fig. 1.9.
5. Tighten the screws attaching the anti-tilt bracket.
6. Push the cooker against the wall so that the anti-tilt bracket is fully inserted in the slot on the cooker's back.

Attention!

When sliding the cooker into place pay special attention not to trap the power supply cable in the stability bracket.

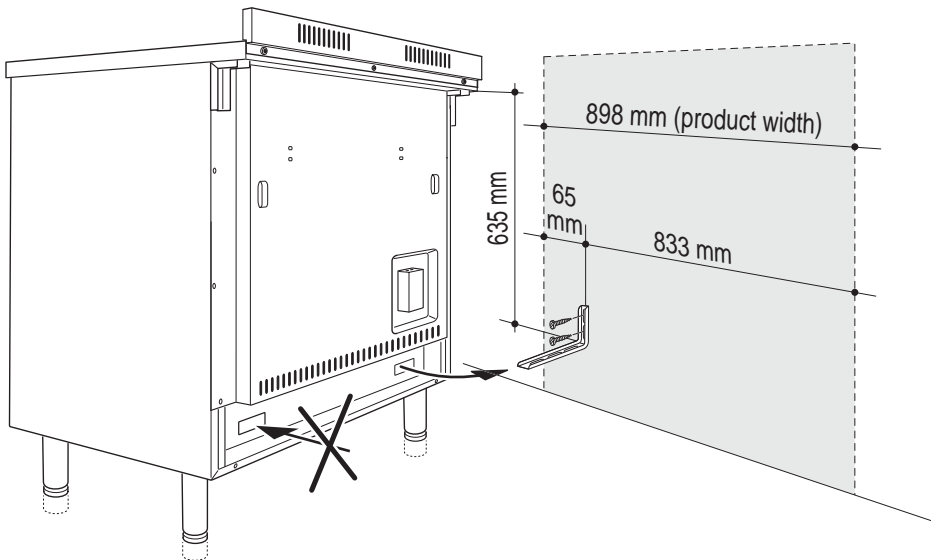

Fig. 1.9

2 - ELECTRICAL SECTION

IMPORTANT: The appliance must be installed by a qualified technician according with the current local regulations and in compliance with the manufacturer instructions. Incorrect installation might cause harm and damage to people, animals or objects, for which the manufacturer accepts no responsibility.

Before carrying out any work on the electrical section of the appliance, it must be disconnected from the mains.

Connection to a good earth wiring system is absolutely essential. The manufacturer accepts no responsibility for any inconvenience caused by failure to comply with this rule.

If the surface is cracked or damaged disconnect the appliance from the mains and contact the After-Sales Service.

The appliance must be connected to the electrical network verifying that the voltage corresponds to the value indicated on the specifications plate and that the cables section of the electrical wiring can bear the load which is indicated on the rating plate.

We recommend that the appliance is connected by a suitably qualified person who will comply with the current IEE and local regulations.

It is recommended that the appliance is connected via a dedicated cooker circuit using a double pole cooker switch with a rating equal or greater than the total loading of the cooker, with a minimum opening between the contacts of 3 mm.

Alternative connection methods may be available as long as they conform to current IEE wiring regulations.

The power supply cable must not touch the hot parts and must be positioned so that it does not exceed 50 °C at any point.

Once the cooker has been installed, the switch must always be easily accessible within 2 metres.

IMPORTANT: This appliance must be connected to a suitable double pole control unit within 2 metres of the cooker.

No diversity can be applied to this control unit.

The control unit must be capable of breaking the full load current of the appliance.

CONNECTION OF THE POWER SUPPLY CABLE

Important! This appliance must be connected to the electricity supply only by an authorised person.

WARNING: If the power supply cable is damaged, it must be replaced only by an authorised service agent in order to avoid a hazard.

To connect the feeder cable to the cooker it is necessary to:

- Unhook the terminal board cover by inserting a screwdriver into the two hooks “A” (fig. 2.1).
- Unscrew the screw “D” and open completely the cable clamp “E” (figs. 2.2).
- Position the U bolts “F” onto terminal board “G” (figs. 2.2) according to the diagrams in fig. 2.3.
- Connect the phase, neutral and earth wires to terminal board “G” according to the diagrams in fig. 2.3.
- Strain the feeder cable and block it with cable clamp “E” (by screwing screw “D”).
- Close the terminal block cover (check the two hooks “A” are correctly hooked).

NOTE: Earth cable must be 3 cm longer than neutral and live cables.

IMPORTANT: To connect the power supply cable **DO NOT** unscrew the screws fixing the cover plate behind the terminal block.

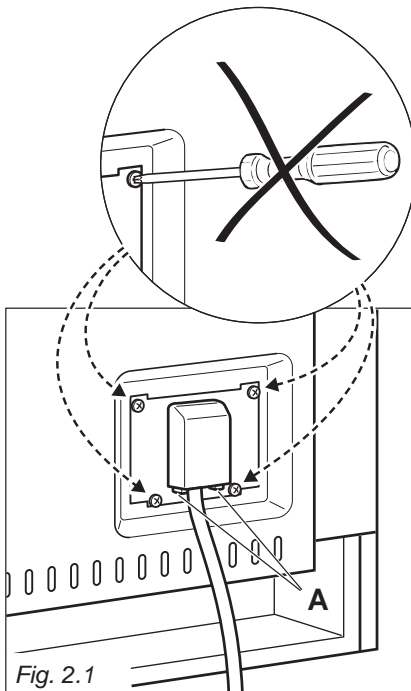
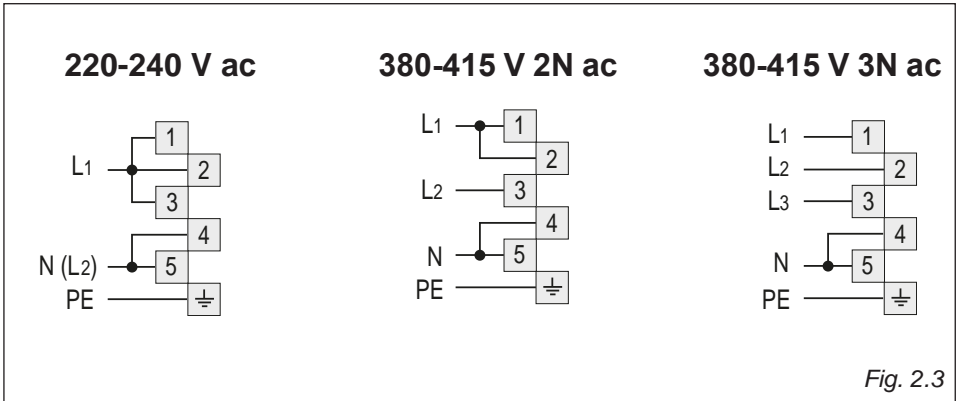
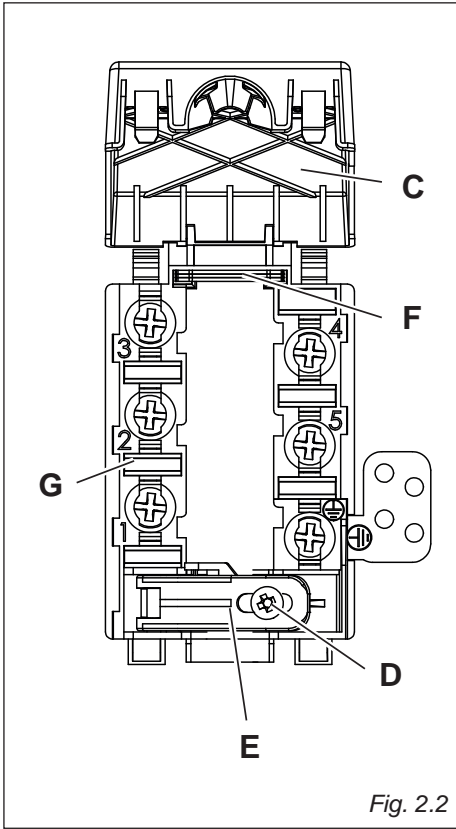



Fig. 2.1

FEEDER CABLE SECTION “TYPE H05RR-F or H05VV-F”

220-240 V ac	3 x 6 mm ² (**)
380-415 V 3N ac	5 x 1,5 mm ² (**)
380-415 V 2N ac	4 x 4 mm ² (**)

(**) Connection with wall box connection.





Advice for the users



1 - COOKING HOB

Fig. 1.1

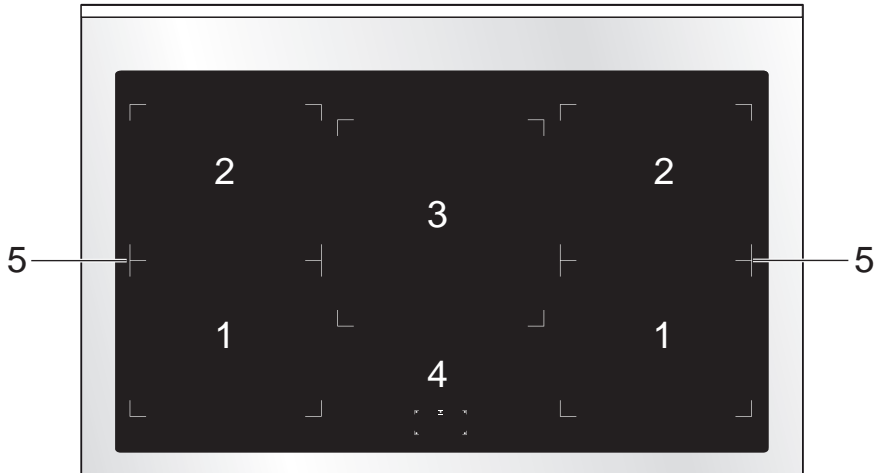

INDUCTION COOKING HOB

- | | | |
|--|-----------|---|
| 1. Induction cooking zone | Multizone | Normal Power: 1600 W
Booster Power: 1850 W |
| 2. Induction cooking zone | Multizone | Normal Power: 2100 W
Booster Power: 3000 W |
| 3. Induction cooking zone | Ø 250 mm | Normal Power: 2300 W
Booster Power: 3000 W |
| 4. Cooking zones display | | |
| 5. "Bridge" function: when enabled, cooking zones 1 and 2 work together as a single zone - 3700 W maximum. | | |

Note:

The Nominal and Booster Power may change depending on the size and material of the pan set on the cooking zone.

Caution! Do not cover the hob with aluminum foils.

Attention:

Detach the appliance from the mains if the ceramic glass is cracked and contact the After-Sales Service.

Metallic objects such as knives, forks, spoons and lids should not be placed on the hob surface since they can get hot.

2 - CONTROL PANEL

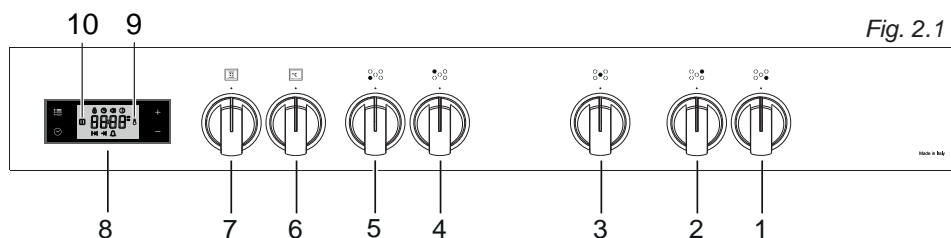

CONTROLS DESCRIPTION

1. Front right cooking zone control knob
2. Rear right cooking zone control knob
3. Central cooking zone control knob
4. Rear left cooking zone control knob
5. Front left cooking zone control knob
6. Multifunction oven thermostat control knob
7. Multifunction oven function selector control knob
8. Electronic clock/programmer "Touch-Control"
9. Oven thermostat indicator
10. Power on indicator

NOTES:

The knobs and symbols may vary.

The symbols may be printed on the knob itself or on the control panel.

Please note: This appliance incorporates a safety cooling fan which you will hear operating whenever the oven or grill is being used.

The cooling fan may even run on after the appliance has been switched off.

The duration of this time is dependent on several factors, including previous cooking temperature, duration and ambient temperature. Times in excess of 30 minutes are not uncommon.

3 - USE OF INDUCTION HOB

The ceramic hob is fitted with induction cooking zones.

These zones, shown by painted disks on the ceramic surface, are controlled by separate knobs positioned on the control panel.

In the front central area of the hob, the cooking zones display indicates:

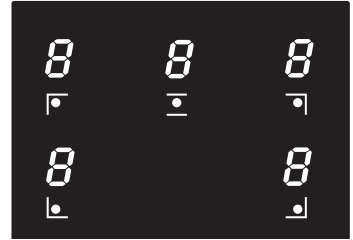











Fig. 3.1

-  = Cooking zone Off (not activated)
-  = Cooking zone On (activated but not operating).
If all the zones are in zero setting, the display switches off automatically (cooking zones Off) after about 10 seconds.
-  = Power levels
-  = “Fast heating” function
-  = “Booster” function
-  = Remaining heat indicator
-  = Pan detection indicator
-  = Childlock safety
-  = “Bridge” function

Note: each lit figure refers to the relevant cooking zone

INDUCTION COOKING SYSTEM

When your induction hob is switched on and a cooking zone has been selected, the electronic circuits produce induced currents that instantaneously heat the bottom of the pan which then transfers this heat to the food.

Cooking takes place with hardly any energy loss between the induction hob and the food. Your induction hob operates only if a correct pan with the right features is placed on a cooking zone. Please refer to “COOKWARE/COFFEE POT FOR INDUCTION COOKING”.

If the pan detection symbol  appears on the display, your pan is not suitable and your induction hob will not operate. After 10 minutes without detecting any pan, the cooking zone switches Off automatically and can only be switched On after the control knob has been returned into “0” (Off) setting.

If the induction cooktop emits a humming noise when a zone is used on a high power level, this phenomenon is normal as it is caused by the induction cooking technology. The noise should weaken or disappear completely when the power level is decreased.

REMAINING HEAT INDICATORS

When the temperature of a cooking zone is still hot, the relevant  remaining heat indicator lights up on the display to alert you of the hot surface.

Avoid touching the hob surface over the cooking area. Please pay special attention to children.

When the  is lit on the display, it is still possible to start cooking again; just turn the control knob to the required power level.

COOKWARE/COFFEE POT FOR INDUCTION COOKING

The induction cooking system OPERATES ONLY if using correct cookware suitable for induction cooking (normally identified by an induction symbol on the bottom of the cookware/ coffee pot). The use of not suitable cookware may cause damage to the appliance.

The bottom of the pan/coffee pot has to be ferromagnetic to generate the electromagnetic field necessary for the heating process (meaning a magnet has to stick to the bottom of the pan/coffee pot).

Pans/coffee pots made from the following materials are not suitable:

- glass, wood, porcelain, ceramic, stoneware;
- pure stainless steel, aluminum or copper without magnetic bottom.

To check if a pan/coffee pot is suitable or not:

- Test the bottom of the pan/coffee pot with a magnet: if the magnet sticks, the pan is suitable.
- If a magnet is not available pour a small amount of water inside the pan/coffee pot and place the pan on a cooking zone. Switch on the cooking zone: if the cooking zone display shows alternately the set power level and , the pan/coffee pot is not suitable .

Important: Do not use pots/coffee pot adaptors; this could cause an overheating and possible damage to the appliance.

Important note: the cooking zones will not operate if the pan/coffee pot diameter is too small. To correctly use the cooking zones follow the indications given in the following table.

Induction cooking zone	Minimum pan diameter recommended (referred to the bottom of the pan)
Multizone (unBridged)	120 mm
Multizone Bridged	230 mm
Cooking zone Ø 250 mm	145 mm

IMPORTANT: Some cookware available on the market is not of good quality or has an effective ferromagnetic area which is much smaller than the diameter of the pan itself. Avoid using this cookware because the induction cooktop may not function properly or may be damaged.

Pay attention: The pan/coffee pot shall always be centred over the middle of the cooking zone.

Pay attention: If using a grill pan do not select the maximum level for a too long time, the pan may become deformed due to the excessive heat. Always use pans with thick bottom. It is possible to use oversized pans/coffee pots but its bottom shall not touch the other cooking zone.

Always use pans/coffee pots with thick, completely flat bottom.

Do not use pans/coffee pots with concave or convex bottom; these could cause overheating of the cooking zone.

Note: Some types of pans/coffee pots could cause noise when used on an induction cooking zone.

The noise does not mean any failure on the appliance and does not influence the cooking operation.

CONTROL KNOBS

Each cooking zone is adjusted by a separate control knob positioned on the control panel and the operation is controlled by the electronic system.

If a cooking zone is not turned Off the electronic system automatically switches it Off after a pre-set time which depends on the power setting.

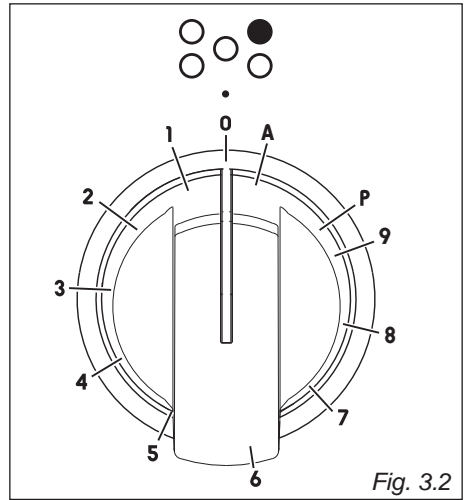

OPERATION TIME LIMIT OF COOKING ZONES

Each cooking zone is automatically switched Off after a maximum preset time if no operation is performed.

The maximum preset time limit depends on the set power level, as illustrated in this schedule.

Each operation on the cooking hob by using the knob will reset the maximum operation time at its initial value.

Power level of cooking zones	Operation time limit
1	360 minutes
2	360 minutes
3	300 minutes
4	300 minutes
5	240 minutes
6	90 minutes
7	90 minutes
8	90 minutes
9	90 minutes
P	10 minutes

NOTES:

The knobs and symbols may vary.
The symbols may be printed on the knob itself.

1 ÷ 9 POWER LEVEL

Turn the knob clockwise to set the desired power level between **1** (minimum) and **9** (maximum).

The power level can be modified at any time by turning the knob clockwise or anti-clockwise to a different setting.

The cooking zone display shows the selected level.

EXAMPLES OF COOKING POWER SETTING		
0	Cooking zone not operating	
1 to 2	Melting Reheating	Sauces, butter, chocolate, gelatine Dishes prepared beforehand
2 to 3	Simmering Defrosting	Rice, pudding, sugar syrup Dried vegetables, fish, frozen products
3 to 4	Steam	Vegetables, fish, meat
4 to 5	Water	Steamed potatoes, soups, pasta, fresh vegetables
5 to 7	Medium cooking Simmering	Meat, liver, eggs, sausages Goulash, roulade, tripe
7 to 8	Cooking	Potatoes, fritters, wafers
9 TO P	Frying, roasting Boiling water	Steaks, omelettes, fried dishes Water

DEEP FAT FRYING

For safety purposes when deep fat frying, do not fill the pan more than one third full of oil. DO NOT cover the pan with a lid and DO NOT leave the pan unattended.



In the unfortunate event of a fire, leave the pan where it is and turn off the control knobs. Place a damp cloth or lid over the pan to smother the flames. Leave the pan to cool for at least 30 minutes before moving the pan.

DO NOT USE WATER ON THE FIRE.



“BRIDGE” FUNCTION (EXTENDABLE MAXI ZONE)



This function can be used to link the two zones 1 and 2 in “Bridge” mode, to create an extended maxi zone which is ideal for large rectangular pans or specialist fish cookware.

To enable this function:

- Turn both control dials for the selected cooking zones clockwise to the highest heat setting 9.
- Turn both dials simultaneously to  and hold until  appears in the cooking zone displays and the displays stop flashing.
- The front cooking zone display will show the heat setting. The rear cooking zone will show .
- The power level can be changed at any time by selecting front cooking zone and then setting the new level.
- To disable the “Bridge” function turn both control dials back to "0"

If no pan is detected



If no pan is detected on rear cooking zone the front cooking zone display shows the selected setting and the rear cooking zone display will alternate between the  and  (CAUTION! the front cooking zone will operate at the selected setting).

If no pan is detected on front cooking zone the front cooking zone display shows the symbol  and the rear cooking zone display will alternate between selected setting and  (CAUTION! the rear cooking zone will operate at the selected setting).

If after 10 minutes no pan is detected:

- the bridging function will switch off.
- the cooking zone without a detectable pan will continue to show 
- the remaining cooking zone will continue cooking at the selected heat setting.

“FAST HEATING” FUNCTION

Turn the control knob anti-clockwise to the **A** setting and then release the knob (after the “beep”); the relative  symbol lights up on the cooking zone display. Within 10 seconds turn the knob to the desired power level (between **1** and **9**); once a setting has been selected,  and the chosen power level will flash in alternation on the control panel display.

This function allows the cooking zone to operate at the maximum power (100%) for a time proportional to the selected power level; after this time the cooking zone will operate at the selected level.

This function is available on all the cooking zones.

While this function is operating it is possible, at any time, to increase the selected power level but it is not possible to decrease the power; by turning the knob anti-clockwise to a lower level the function will be disabled.

The function will be disabled also by turning the knob to the “**0**” (Off) position or by selecting the “Booster” function.

Note: If removing the pan from the cooking zone before the programme has been completed, the “Fast heating” function will be completed with the remaining time if the pan is put back on the cooking zone within 10 minutes.

“BOOSTER” FUNCTION

Turn the control knob clockwise to set the maximum power level (**9**), then turn clockwise again to the “**P**” setting and release the knob (after the “beep”); the control knob returns to the maximum setting (**9**) automatically and the relative  symbol lights up on the cooking zone display.

The “Booster” program is now operative.

This function allows the cooking zone to operate at the Booster maximum power (above the nominal power) for maximum 10 minutes; it could be used, for example, to rapidly heat up large amount of water.

To disable this function turn the knob anti-clockwise to a lower power level or to the “**0**” (Off).

The “Booster” is also disabled by turning the knob again to the “**P**” setting; in this case the cooking zone operates at the power level **9**.

Note: if a cooking zone is still hot, it is not possible to use the “Booster” function and  will flash if you try to activate. The cooking zone is automatically set to the maximum power level (**9**).

The “Booster” function is always limited to a maximum of 5 minutes. You can activate the “Booster” function again after 5 minutes.

IMPORTANT NOTES: The “BOOSTER” function is not suitable for use with non water based cooking.

Do not use this function for heating oil (e.g. deep fat frying)

Important:

- You can set two cooking zones for the "Booster" function at the same time, as per figure 3.3.
- It is not possible to set more than two cooking zones (i.e. 3, 4, 5) for the "Booster" function at the same time.
- If you try to set the "Booster" function for a configuration which is not possible (e.g. "Booster" function already set for two zones), the electronics automatically manage the maximum allowed power level for the zone being set (figure flashing for a few seconds on the display).

Fig. 3.3

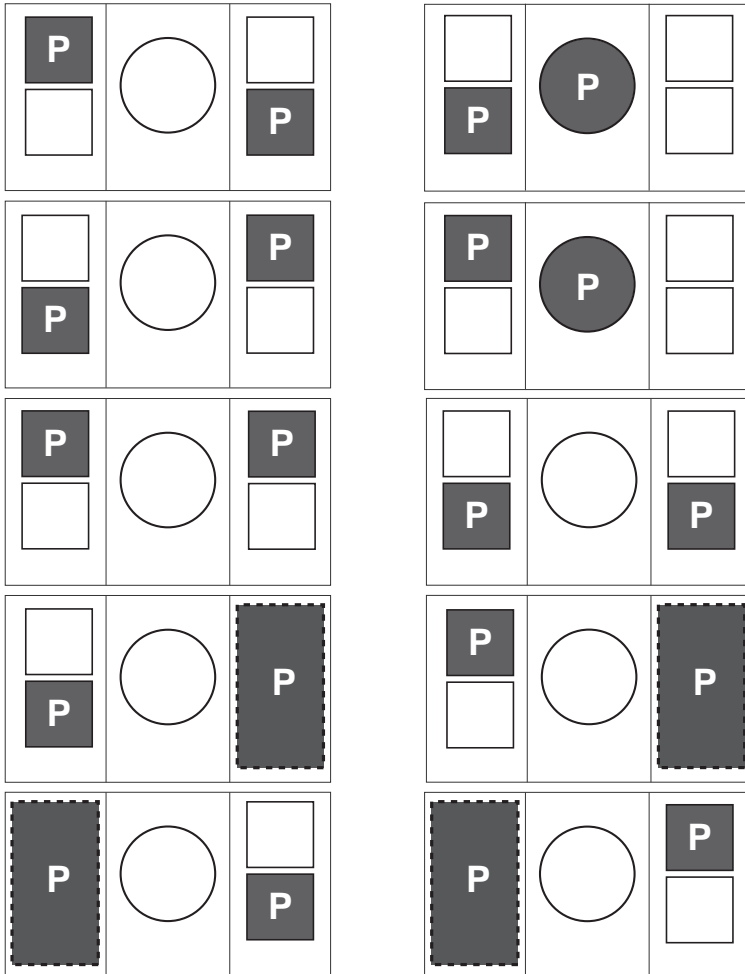

MAXIMUM USABLE POWER FOR THE COOKING ZONES

The induction cooktop is divided in two areas to manage the maximum usable power:

- left zones (area 1);
- central & right zones (area 2).

The two areas can be used at the same time but the maximum total power per each one is 3700 W.

Should the cooking zones of one area require more than 3700 W, the power of the zone being set is automatically reduced, by the electronics, to the remaining power available.

If this occurs, the cooking zone will display a flashing figure for a few seconds before automatically displaying the new power level.

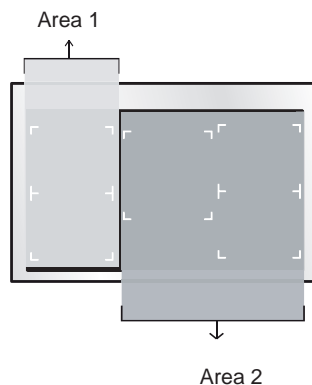

THERMAL PROTECTIONS

The induction hob is fitted with safety devices to protect the electronic system and to protect each cooking zone from overheating.

In case of overheating, one of the following automatic functions could be started by the electronic system:

- “Booster” program deleted and power reduced;
- one or more cooking zone switched Off;
- cooling fan motor of the induction unit switched on.



CHILDLOCK SAFETY

When not using the induction hob, set the childlock safety to prevent children from accidentally switching on the cooking zones.

Ensure all cooking zones are switched Off, then turn the control knobs of the left cooking zones simultaneously to the left (**A** setting) and hold the knobs in this position until  lights up on the cooking zones display; then release the knobs.

To deactivate the childlock repeat the same procedure until  lights up on the cooking zones display; then release the knobs.

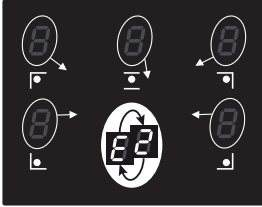
ERROR CODES ON THE COOKING ZONES DISPLAY

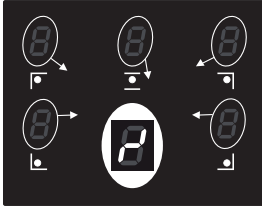
Error code	Example	What to do
<p>Erxx or Ex (not E2 or EH)</p> <p>or</p> <p>display not operative</p>		<ol style="list-style-type: none"> 1. Switch off the cooker and disconnect it from the mains. 2. Wait for about 1 minute, then reconnect the cooker and turn on the cooking zones. 3. Wait for about 1 minute and if the error message does not appear again the cooking zones can be used. 4. If the error message does not disappear repeat step from 1 to 3. 5. If the problem continues do not use the induction hob (only use the oven) and contact your Authorised Service Centre.
<p>E2</p> <p>or</p> <p>EH</p>		<p>E and 2 alternating for one or more cooking zones.</p> <p>This indicates an overheating of the cooking zone/s.</p> <ol style="list-style-type: none"> 1. Switch off the cooking zone/s and leave to cool. 2. If the problem continues do not use the induction hob (only use the oven) and contact your Authorised Service Centre.
<p>E6</p> <p>or</p> <p>display not operative</p>		<p>The cooker has been incorrectly connected.</p> <p>The appliance shall be connected to the appropriate power supply by a qualified technician.</p>
<p>Symbol as per side figure</p>		<p>This indicates an incorrect operation of one or more cooking zone control knob.</p> <ol style="list-style-type: none"> 1. Turn the cooking zone control knobs to the "0" (Off) position, then switch off the cooker and disconnect it from the mains. 2. Wait for about 1 minute, then reconnect the cooker and turn on the cooking zones. 3. Wait for about 1 minute and if the error message does not appear again the cooking zones can be used. 4. If the error message does not disappear repeat step from 1 to 3. 5. If the problem continues do not use the induction hob (only use the oven) and contact your Authorised Service Centre.

ADVICE FOR SAFE USE OF THE HOB

- Before switching on make sure that you have the correct knob for the hotplate chosen. It is advisable to put the pan on the hotplate before switching on and to take it away after switching off.
- Use cookware with flat and even bottoms. Uneven bottoms can scratch the glass ceramic surfaces. Be careful that the bottom is clean and dry.
- Do not leave wet or damp lids on the hob.
- The glass-ceramic surface and pans must be clean. Carefully eliminate any food remains (especially containing sugar), dirt etc. with the aid of a cleansing agent.
- Make sure that the handles of cookware do not stick out over the edge of the cooker, to avoid them being knocked over by accident. **This also makes it more difficult for children to reach the cooking vessels.**
- Do not lean over the cooking zones when they are switched on.
- Do not drop heavy or sharp objects on the glass ceramic cooktop. **If the surface is broken or damaged unplug the cooktop and contact the after-sales service.**
- Do not put aluminum foil or plastic objects on the cooking zones when they are hot.
- Follow the cleaning instructions carefully.

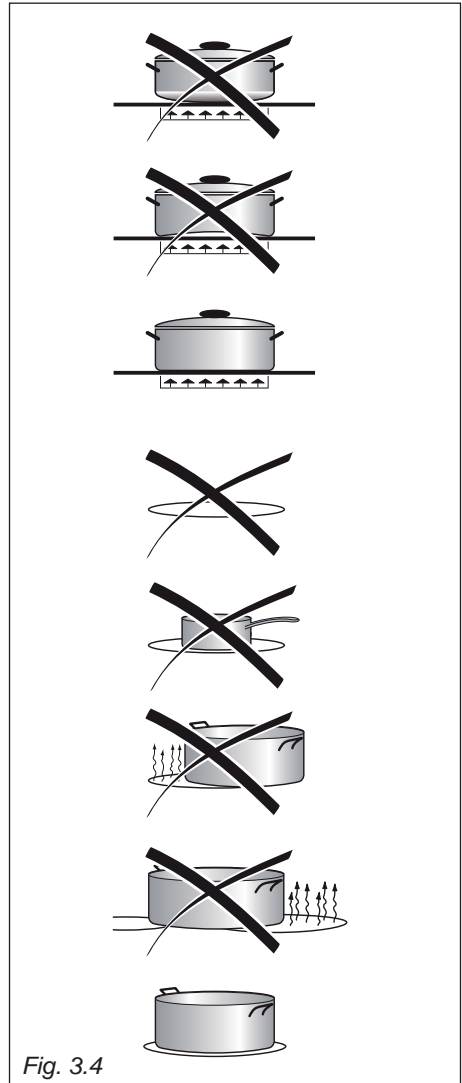

Fig. 3.4

DO NOT USE PANS WITH ROUGH CIRCULAR MACHINED BASE.



Fig. 3.5

CLEANING THE CERAMIC HOB

GENERAL ADVICE

- **Before you begin cleaning, you must ensure that the appliance is switched off and disconnected from the electrical power supply.**
- It is advisable to clean when the appliance is cold.
- Avoid leaving alkaline or acidic substances (lemon juice, vinegar, etc.) on the surfaces.
- Avoid using cleaning products with a chlorine or acidic base.
- **Do not use a steam cleaner because the moisture can get into the appliance thus making it unsafe.**
- **Important: The use of suitable protective clothing/gloves is recommended when handling or cleaning of this appliance.**
- **Do not scratch the cooktop with cutting or sharp objects.**

CLEANING THE CERAMIC HOB

- Remove any encrustation using the scraper provided.
- All traces of the cleaner have to be removed with a damp cloth.
- If you use a detergent, please make sure that it is not abrasive or scouring. Abrasive or scouring powders can damage the glass surface of the hob.
- All traces of the cleaner must be removed with a damp cloth.
- Dust, fat and liquids from food that has boiled over must be removed as soon as possible.
- If they are allowed to harden they become increasingly difficult to remove. This is especially true in the case of sugar/syrup mixtures which could permanently pit the surface of the hob if left to burn on it.
- If any of these products has melted on the ceramic surface, you should remove it immediately (when the surface is still hot) by using the scraper (not supplied with the appliance) to avoid any permanent damage to the surface of the hob.
- Do not put articles on the hob which can melt: i.e. plastic, aluminum foil, sugar, sugar syrup mixtures etc.
- Avoid using any knife or sharp utensil since these can damage the ceramic.
- Do not use steel wool or an abrasive sponge which could scratch the surface in an irreparable way
- **Do not use the glass ceramic surface as a work surface.**

ATTENTION: MOST IMPORTANT!
If cleaning the glass ceramic hob using a special tool (i.e. scraper) take extra care to avoid damage to the seal at the edges of the glass ceramic surface.

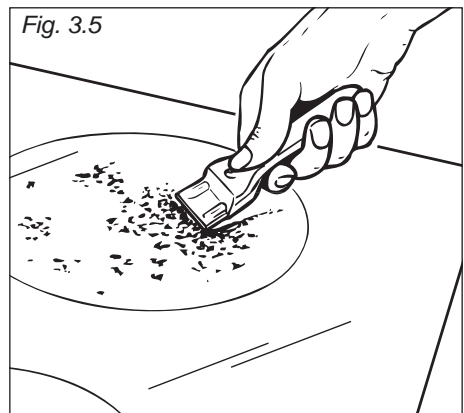

4 - MULTIFUNCTION OVEN

GENERAL FEATURES



As its name indicates, this is an oven that presents particular features from an operational point of view.

In fact, it is possible to insert 8 different programs to satisfy every cooking need.

The 8 positions, thermostatically controlled, are obtained by 4 heating elements which are:

- Bottom element
- Top element
- Grill element
- Circular element

NOTE:

Upon first use, it is advisable to operate the oven (at the maximum temperature) for 60 minutes in the position  and for another 15 minutes in the positions  and , to eliminate possible traces of grease on the heating elements.

Smells and fumes produced during this burn off process are not a cause of alarm. Adequate ventilation should however be provided in the room where the appliance is installed, e.g. by opening a window.

Clean the oven and accessories with warm water and washing-up liquid.

Attention: The oven door becomes very hot during operation. Keep children away.

WARNING: The door is hot, use the handle.

WARNING: During use the appliance becomes hot. Care should be taken to avoid touching heating elements inside the oven.

Do not line the oven walls or base with aluminum foil.

Do not place baking trays or the drip tray on the base of the oven chamber.

OPERATING PRINCIPLES

Heating and cooking in the MULTIFUNCTION oven are obtained in the following ways:

- by normal convection**
The heat is produced by the upper and lower heating elements.
- by forced convection**
A fan draws in the air contained in the oven, which circulates it through the circular heating element and then forced back into the oven by the fan. Before the hot air is drawn back again by the fan to repeat the cycle, it envelops the food in the oven, provoking a complete and rapid cooking. It is possible to cook several dishes simultaneously.
- by semi-forced convection**
The heat produced by the upper and lower heating elements is distributed throughout the oven by the fan.
- by radiation**
The heat is radiated by the infra red grill element.
- by radiation and ventilation**
The radiated heat from the infra red grill element is distributed throughout the oven by the fan.
- by ventilation**
The food is defrosted by using the fan only function without heat.

Before introducing the food, preheat the oven to the desired temperature.

For a correct preheating operation, it is advisable to remove the tray from the oven and introduce it together with the food, when the oven has reached the desired temperature.

Check the cooking time and turn off the oven 5 minutes before the theoretical time to recuperate the stored heat.

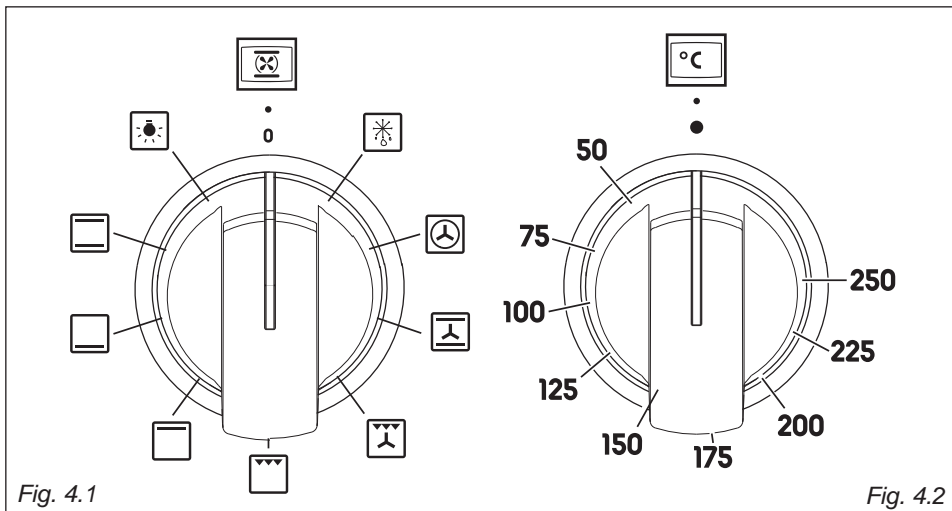

NOTES:

The knobs and symbols may vary.

The symbols may be printed on the knob itself or on the control panel.

THERMOSTAT KNOB (fig. 4.2)

To turn on the heating elements of the oven, set the function selector knob on the desired program and the thermostat knob onto the desired temperature.

To set the temperature, it is necessary to make the knob indicator meet the chosen number. The elements will turn ON or OFF automatically according to the energy need which is determined by the thermostat.

The thermostat indicator light on the control panel will illuminate when the oven is switched on and turns off when the oven reaches the correct temperature.

The light will cycle on and off during cooking.

FUNCTION SELECTOR KNOB (fig. 4.1)

Rotate the knob clockwise to set the oven for one of the following functions:



OVEN LIGHT

By turning the knob onto this setting we light the oven cavity.

The oven remains alight while any of the functions is on.



TRADITIONAL CONVECTION COOKING

The upper and lower heating elements are switched on.

The heat is diffused by natural convection and the temperature must be regulated between 50 °C and the maximum temperature with the thermostat knob.

It is necessary to preheat the oven before introducing the foods to be cooked.

Recommended for:

For foods which require the same cooking temperature both internally and externally, i. e. roasts, spare ribs, meringue, etc.



LOWER HEATING ELEMENT

In this position only the lower element is switched on. Heat is distributed by natural convection.

The temperature must be regulated between 50 °C and 200 °C maximum position with the thermostat knob.

Recommended for:

To complete cooking of dishes that require higher temperature at the bottom.



UPPER HEATING ELEMENT

In this position only the upper element is switched on.

Heat is distributed by natural convection.

For normal cooking the temperature must be regulated between **50 °C** and **250 °C** maximum.

Recommended for:

This mode is particularly suitable to complete cooking of dishes that require higher temperature at the top; for faster, more even leavening, all types of flour-based doughs and fresh, home-made pasta.



GRILLING

The infra-red heating element is switched on. The heat is diffused by radiation.

Use with the **oven door closed** and the thermostat knob to between 50 °C and 225 °C .

Preheat the oven for about 5 minutes.

Introduce the food to be cooked, positioning the rack as close to the grill as possible.

The dripping pan should be placed under the rack to catch the cooking juices and fats.

Use with the oven door closed.

Note: It is recommended that you do not grill for longer than 30 minutes at any one time.

Attention: The oven door becomes very hot during operation. Keep children away.

Recommended for:

Intense grilling action for browning, crisping, "au gratin", toasting, etc.



VENTILATED GRILL COOKING

The infra-red ray grill and the fan are on. The heat is mainly diffused by radiation and the fan then distributes it throughout the oven.

The temperature must be regulated between 50 °C and 225 °C maximum **for max 30 minutes**, with the thermostat knob.

It is necessary to preheat the oven for about 5 minutes.

Use with the oven door closed.

Attention: the oven door becomes very hot during operation. Keep children away.

For correct use see chapter "GRILLING AND AU GRATIN".

Recommended for:

For grill cooking when a fast outside browning is necessary to keep the juices in, i. e. veal steak, steak, hamburger, etc.



CONVECTION COOKING WITH VENTILATION

The upper and lower heating elements and the fan turn on.

The heat coming from the top and bottom is diffused by forced convection.

The temperature must be regulated between 50 °C and the maximum temperature with the thermostat knob.

Recommended for:

For foods of large volume and quantity which require the same internal and external degree of cooking; for i.e.: rolled roasts, turkey, legs, cakes, etc.



HOT AIR COOKING

The circular element and the fan are on.

The heat is diffused by forced convection and the temperature must be regulated between 50 °C and the maximum temperature with the thermostat knob.

It is not necessary to preheat the oven.

Recommended for:

For foods that must be well done on the outside and tender or rare on the inside, i. e. lasagna, lamb, roast beef, whole fish, etc.



DEFROSTING FROZEN FOODS - ECO FUNCTION (ENERGY SAVING)

With the thermostat knob on “●” only the oven fan is on.

The defrosting is done by simple ventilation without heat.

Recommended for:

To rapidly defrost frozen foods; 1 kilogram requires about one hour.

The defrosting times vary according to the quantity and type of foods to be defrosted.

ECO FUNCTION (ENERGY SAVING):

The upper and lower heating elements and the fan turn on.

The heat coming from the top and bottom is diffused by forced convection.

This function reduces the appliance's energy consumption, it is therefore particularly beneficial for the gentle cooking of small quantities of food on a single shelf.

It is not necessary to preheat the oven and use with the oven door closed.

Cooking times may be longer than standard functions.

Do not use this function to preheat the oven.

Recommended for:

Foods that require gentle cooking. To keep foods hot after cooking. To slowly heat already cooked foods.

5 - OVEN TEMPERATURE GUIDE

Cooking process	Oven heat	Gas mark	Electric oven temperature	
			°C	°F
Keeping food hot, milk puddings	very cool	½	120	250
Egg custards	cool	1	140	275
Rich fruit cakes, braising	cool	2	150	300
Low temperature roasting, shortbread	moderate	3	160	325
Victoria sandwich, plain fruit cake, baked fish	moderate	4	180	350
Small cakes, choux pastry	fairly hot	5	190	375
Short pastry, Swiss rolls, soufflés	fairly hot	6	200	400
High temperature roasting, flaky pastry, scones	hot	7	220	425
Puff pastry, bread	very hot	8	230	450
Small puff pastries, browning cooked foods	very hot	9	240	475

These temperatures relate to the centre oven temperature.

Remember to use ovenproof dishes and to adjust the oven temperature during cooking if necessary.

NOTE: Reduce the oven temperature by 10 – 20 °C for fan assisted ovens. For dishes that take over an hour to cook, reduce the cooking time by 10 minutes per hour.

6 - ELECTRONIC CLOCK "TOUCH-CONTROL"

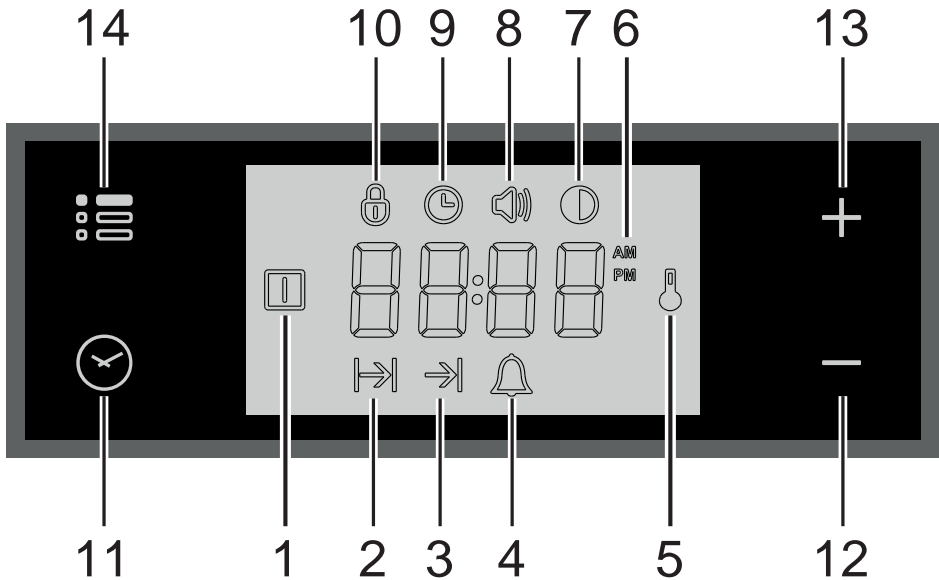

Description of display symbols:

1. Oven on
2. Cooking time
3. End of cooking time
4. Timer
5. Oven temperature
6. AM/PM time format
7. Screen brightness
8. Acoustic signal volume
9. Time of day setting
10. Programmer 'touch' control panel key lock

Description of the 'touch control' panel symbols:

11. Program selection
12. Digit backward setting for all functions
13. Digit forward setting for all functions
14. Menu selection

IMPORTANT NOTE: When using the timer and during a semi-automatic or automatic cooking, the countdown of the function with less time remaining prevails on the display.

ATTENTION - MOST IMPORTANT:

ELECTRONIC PROGRAMMER DISPLAY CLEANING

Strictly follow the information indicated in the chapter "CLEANING AND MAINTENANCE".

“TOUCH-CONTROL” KEYS

The “touch-control” keys shall be operated by the fingers (just by touching the key).

When using touch controls it is best to use the ball of your finger rather than the tip.

Program and menu selection: after starting the procedure, the selection is automatically deactivated after approx. 5 seconds from the last touch on the display.

SETTING THE CLOCK

When connecting for the first time, or after a power failure, the word “OFF” flashes on the display and the “🕒” symbol is lit. Adjust the time touching the “+” or “-” key.

Important: The oven does not operate, in manual cooking, without first having set the clock.

To change the time with the appliance already installed, touch the “🕒” key for more than 2 seconds, then touch it again until the “🕒” symbol flashes. Then adjust the time, within 5 seconds, using the “+” or “-”.

Important: It is not possible to adjust the clock if a cooking program is in progress.

USING THE TIMER

You can use the timer at any time, even when the oven is not in use.

ATTENTION - MOST IMPORTANT: This is only an alarm that DOES NOT switch off the oven or grill.

REMEMBER TO TURN OFF THE OVEN/GRILL MANUALLY.

The timer can be set for a maximum time of 23 hours and 59 minutes.

1. To set the timer, with the appliance already connected, touch the “🕒” key (several times) until the “🔔” symbol flashes on the display. Set the time (increase in minutes) within 5 seconds using the “+” or “-” key. At the end of the adjustment the display shows the countdown.
2. At the end of the count, the timer starts beeping and the “🔔” symbol flashes on the display. Touch any key to turn off the acoustic signal that would otherwise stop after 7 minutes.
3. Turn the oven off manually (switch and thermostat knobs in the off position) if you do not wish to continue with manual cooking.

To reset the timer in operation at any time:

- 1A. Only timer function active (no semi-automatic or automatic cooking in progress): touch the “🕒” key for 3 seconds..
- 1B. With semi-automatic or automatic cooking in progress: touch the key several times “🕒” until the “🔔” symbol flashes on the display. Then touch the “-” key within 5 seconds until “00:00” appears on the display.
2. The time of day is shown on the display.

SEMI-AUTOMATIC COOKING

This is used to automatically switch off the oven after the desired cooking time has elapsed. Check the clock shows the correct time.

The semi-automatic cooking program can be set for a maximum period of 10 hours.

1. Select the function and temperature (function and temperature knobs). The oven will come on.
2. Touch the "⏸" key until the "⏸" symbol flashes on the display. Set the cooking time (increase in minutes - consider the preheating time, if necessary) within 5 seconds using the "+" or "-". At the end of the adjustment the display shows the countdown.
3. At the end of the count the oven turns off, the timer starts beeping, the "⏸" symbol flashes and the word "End" appears on the display.
4. Turn the temperature and function knobs to the off position.
5. Touch the "⏸" key to deactivate the acoustic signal (which otherwise will stop after 7 minutes) and to return the programmer to manual mode (the time is shown on the display). If instead the acoustic signal is deactivated with one of the other keys, after deactivation also touch the "⏸" key to return the programmer to manual mode (the time is shown on the display).

To cancel the semi-automatic cooking program at any time:

- 1A. Only semi-automatic cooking function active (no timer in use): touch the "⏸" key for 3 seconds, the "⏸" symbol and the word "End" are shown on the display.
- 1B. With active timer: touch the "⏸" key several times until the "⏸" symbol flashes. Then touch the "-" key within 5 seconds until "00:00" appears on the display, replaced after a few seconds by the "⏸" symbol and the word "End".
2. Touch the "⏸" key again to return the programmer to manual mode (the time of day is shown on the display). If cooking is finished turn the temperature and function knobs to the off position, otherwise continue cooking and then remember to turn the oven off manually.

AUTOMATIC COOKING

Use automatic cooking to automatically turn the oven on, cook, and then turn the oven off. Check the clock shows the correct time.

1. Select the function and temperature (function and temperature knobs). The oven will come on.
2. Decide the cooking time considering the preheating time, if necessary, and set it as described above in the "SEMI-AUTOMATIC COOKING" chapter.
3. Touch the "⏸" key several times until the "⏸" symbol appears on the display. Then set the time at which you want the oven to turn off, touching the "+" or "-" key.
4. If the cooking is not started immediately, the display shows the current time of day and the "⏸" and "⏸" symbols. The oven turns off but now it is set for automatic operation.
 - To check the cooking time, touch the "⏸" key once, the "⏸" symbol flashes.
 - To check the turn-off time, touch the key "⏸" several times until the "⏸" symbol flashes.

To cancel the automatic cooking program at any time, proceed as described in the “SEMI-AUTOMATIC COOKING” chapter.

Turn the temperature and function knobs to the off position, otherwise continue cooking and then remember to turn the oven off manually.

ATTENTION - VERY IMPORTANT (AUTOMATIC OR SEMI-AUTOMATIC COOKING):

If a very short power interruption occurs, the oven keeps the programming.

If the interruption is instead longer than a few tens of seconds, the automatic cooking is cancelled. In this case, turn the temperature and function knobs to the off position and restart programming if necessary.



USER PREFERENCES SETTINGS

PROGRAMMER ‘TOUCH CONTROL’ PANEL KEY LOCK



This function is used to prevent the accidental touch of the programmer selection keys and to avoid unintentionally activating or modifying its functions.

The key lock can be activated at any time, with a cooking in progress or with the oven off.

To lock:



- Touch the " " key for more than 2 seconds until the " " indicator light starts flashing. Then touch the “+” key to activate the key lock, the word "On", appears on the display, wait a few seconds until the operation is completed. When this function is active, the " " indicator light is on.

To unlock:

- Touch the " " key for more than 2 seconds until the " " indicator light starts flashing. Then touch the “-” key to deactivate the key lock, the word "OFF" appears on the display, wait a few seconds until the operation is completed. When this function is not active, the " " indicator light is off.



ACOUSTIC SIGNAL TONE SETTING

It is possible to select three sound tones.

- Touch the " " key for more than 2 seconds, then touch the same key several times until the " " symbol flashes.
- Touch the “+” or “-” key; the display shows the tone set (“b-01”, “b-02” or “b-03”).
- The last tone displayed remains active.

SCREEN BRIGHTNESS SETTING

It is possible to select three brightness levels.

- Touch the " " key for more than 2 seconds, then touch the same key several times until the " " symbol flashes.
- Touch the "+ " or " - "; key; the display shows the brightness set ("d-01", "d-02" or "d-03").
- The last brightness displayed remains active.

TIME FORMAT

It is possible to choose the 24 hour or 12 hour clock format.

- To activate the 12 hour format, touch the "+", key for more than 5 seconds until the " AM " or " PM " symbol is activated.
- To activate the 24 hour format, touch the "+", key for more than 5 seconds until the " AM " or " PM " symbol is deactivated.

7 - CLEANING AND MAINTENANCE

GENERAL ADVICE

- **Before you begin cleaning, you must ensure that the appliance is switched off at the cooker switch.**
- It is advisable to clean when the appliance is cold and especially when cleaning the enamelled parts.
- Avoid leaving alkaline or acidic substances (lemon juice, vinegar, etc.) on the surfaces.
- Avoid using cleaning products with a chlorine or acidic base.
- Clean the surfaces with a damp cloth and using neutral, non-aggressive detergents. Complete the cleaning with a dry, clean cloth.
- **Avoid using cleaning products with a chlorine or acidic base.**
- **Important: The use of suitable protective clothing/gloves is recommended when handling or cleaning this appliance.**
- **Under no circumstances should any external covers be removed for servicing or maintenance except by suitable qualified personnel.**

WARNING:

When correctly installed, your product meets all safety requirements laid down for this type of product category. However special care should be taken around the rear or the underneath of the appliance as these areas are not designed or intended to be touched and may contain sharp or rough edges, that may cause injury.

Important: The manufacturer declines all liability for possible damage caused by the use of unsuitable products to clean the appliance.

Attention! The appliance gets very hot, mainly around the cooking areas. It is very important that children are not left alone in the kitchen when you are cooking.

Do not use a steam cleaner because the moisture can get into the appliance thus make it unsafe.

Do not use harsh abrasive cleaners or sharp metal scrapers to clean the oven door glass since they can scratch the surface, which may result in shattering of the glass.

CLEANING

- **Control panel facia:** Clean very carefully with water and neutral soap; the cloth used must be rinsed well and must be free of any cleaning chemicals to avoid damaging any screen print on the facia.
- **Door, glass & painted surfaces:** Clean very carefully with water and neutral soap; the cloth used must be rinsed well and must be free of any cleaning chemicals.
- **Inside of oven:** The oven should always be cleaned after use when it has cooled down. The cavity should be cleaned using a mild detergent solution and warm water. Suitable proprietary chemical cleaners may be used only on enamel after first consulting the instructions supplied with the oven cleaner and testing a small sample on the oven cavity. Abrasive cleaning agents or scouring pads/cloths should not be used on the cavity surface.

NOTE: The manufacturers of this appliance will accept no responsibility for damage caused by chemical or abrasive cleaning.

Let the oven cool down and pay special attention not to touch the hot heating elements inside the oven cavity.

STAINLESS STEEL, ALUMINUM PARTS, PAINTED AND SILK-SCREEN PRINTED SURFACES

Clean using an appropriate product.

Always dry thoroughly.

IMPORTANT: these parts must be cleaned very carefully to avoid scratching and abrasion. You are advised to use a soft cloth and neutral soap.

CAUTION: Do not use abrasive substances or non-neutral detergents as these will irreparably damage the surface.

VITROCERAMIC COOKING HOB

– See page 34.

ENAMELLED PARTS

All the enamelled parts must be cleaned with a sponge and soapy water or other non-abrasive products.

Dry preferably with a microfibre or soft cloth.

Acidic substances like lemon juice, tomato sauce, vinegar etc. can damage the enamel if left too long.

INSIDE OF OVEN

The oven should always be cleaned after use when it has cooled down.

The cavity should be cleaned using a mild detergent solution and warm water. Suitable proprietary chemical cleaners may be used after first consulting with the manufacturers recommendations and testing a small sample of the oven cavity. Abrasive cleaning agents or scouring pads/cloths should not be used on the cavity surface.

NOTE: The manufacturers of this appliance will accept no responsibility for damage caused by chemical or abrasive cleaning.

Let the oven cool down and pay special attention no to touch the hot heating elements inside the oven cavity.

Fire risk! Do not store flammable material in the oven.

ELECTRONIC PROGRAMMER DISPLAY CLEANING

Clean the programmer display using a soft cloth, warm water and neutral soap, or a soft cloth with a liquid detergent (non-abrasive).

When cleaning, be careful to move the cloth in one direction only.

Then wipe the display with a damp cloth and dry it with a soft cloth.

IMPORTANT:

DO NOT use chlorine-based or acid-based cleaning products, abrasive products or non-neutral detergents as they may cause irreparable damage to the surface. DO NOT spray cleaning liquids directly on the programmer display.

ASSEMBLY AND DISMANTLING OF THE SIDE RUNNER FRAMES

1. Models with embossed cavity

The oven shelf must be inserted operating as per figure 7.1.

The oven shelf is provided with a security block to prevent accidental extraction.

It must be inserted operating as per figure 7.1.

To pull it out operate in the inverse order.

2. Models with side runner frames:

- Assemble the wire racks to the oven walls using the 2 screws (fig. 7.2).

In the models with catalytic panels supplied: interpose the catalytic panels "A" with the arrow up (fig. 7.2).

- Slide in, on the guides, the shelf and the tray (fig. 7.3).
- The shelf must be fitted so that the safety catch, which stops it sliding out, faces the inside of the oven; the guard rail shall be at the back.
- To dismantle, operate in reverse order.

ADVICE FOR USE AND MAINTENANCE OF SELF CLEANING PANELS

The self cleaning panels are covered with a special microporous enamel which, absorbs and removes oil and fat splashes during normal baking over 200 °C.

If, after cooking very fatty foods, the panels remain dirty, operate the oven empty on max temperature for about 30 minutes.

These panels do not require to be cleaned, however it is advised to periodically remove them from the oven (at least the side panels) and to wash them with tepid soapy water and then wipe off with a soft cloth.

DO NOT CLEAN OR WASH THEM WITH ABRASIVE PRODUCTS OR WITH PRODUCTS CONTAINING ACIDS OR ALKALIS.

The side panels are reversible and when the microporous enamel degrades, they can be turned to the other side.

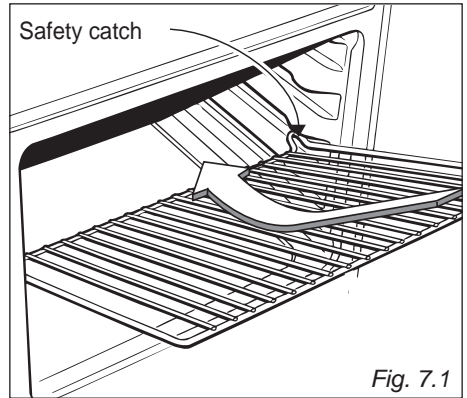

Fig. 7.1

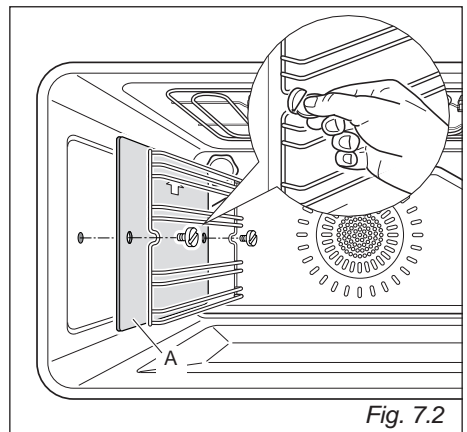

Fig. 7.2

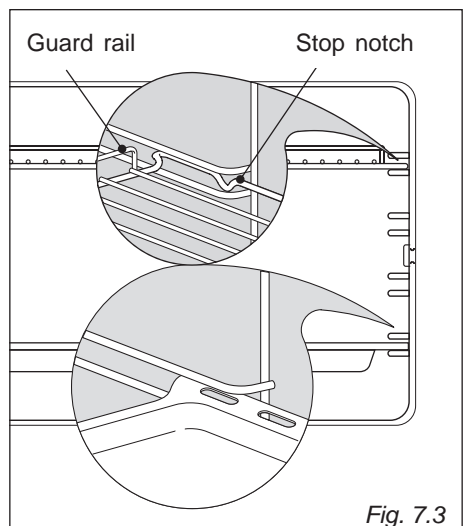

Fig. 7.3

TELESCOPIC SLIDING SHELF SUPPORTS (some models only)

The telescopic sliding shelf support makes it safer and easier to insert and remove the oven shelf.

It stops when it is pulled out to the maximum position.

Important! When installing the sliding shelf support, make sure that you fit:

- The slides to the top wire of a rack. They do not fit on the lower wire.
- The slides so that they run out towards the oven door.
- Both sides of each pair of shelf slides.
- Both sides on the same level.

To fix the sliding shelf supports onto the side racks:

- Fit the side runner frames into the holes on the side walls inside the oven. (fig. 7.2).
- Fit the sliding shelf supports onto the top wire of a rack and press (fig. 7.4). You will hear a click as the safety locks clip over the wire.

IMPORTANT NOTE: When cooking with the rotisserie DO NOT position the grill tray on the sliding shelf supports.

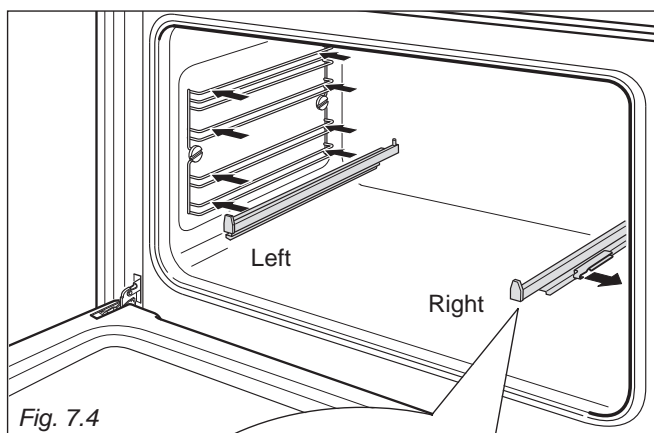

To remove the RH and LH sliding guides from the wire support:

- Remove the side racks by unscrewing the fixing screws (fig. 7.5a).
- Lay down the sliding shelf support and side racks, with the telescopic sliding shelf support underneath.
- Find the safety locks. These are the tabs that clip over the fixing wire (arrow 1 in fig. 7.5b).
- Pull the safety locks away from the fixing wire to release the sliding guide (arrow 2 in fig. 7.5b).

Cleaning the sliding shelf supports:

- Wipe the supports with a damp cloth and a mild detergent only.
- Do not wash them in the dishwasher, immerse them in soapy water, or use oven cleaner on them.

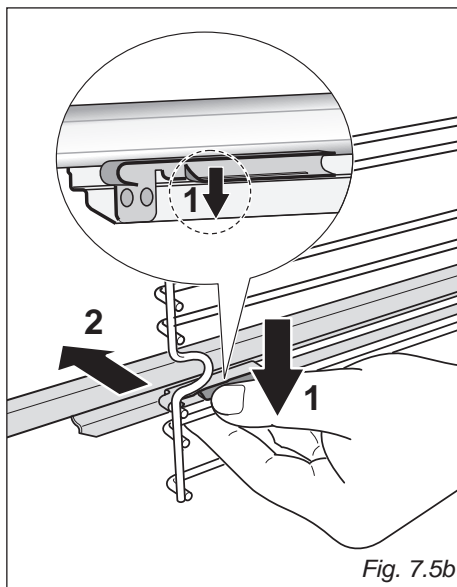
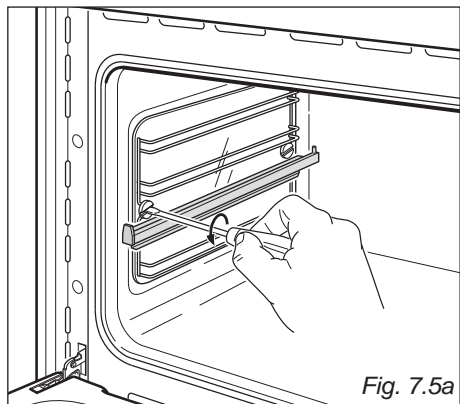

REPLACING THE OVEN LAMPS

WARNING: Ensure the appliance is switched off and disconnected from the electrical power supply before replacing the lamp to avoid the possibility of electric shock.

- Let the oven cavity and the heating elements to cool down;
- Switch off the electrical supply;
- Remove the protective cover "A" (fig. 7.6);
- Replace the halogen lamp "B" with a new one suitable for high temperatures (300 °C) having the following specifications: 220-240V, 50-60 Hz and same power (check watt power as stamped in the lamp itself) of the replaced lamp;

IMPORTANT WARNING: Never replace the bulb with bare hands; contamination from your fingers can cause premature failure. Always use a clean cloth or gloves;

- Refit the protective cover "A";

Note: Oven bulb replacement is not covered by your guarantee.

The intended purpose of the lamps, fitted on this appliance, is to illuminate the oven cavity and thus help the user to better monitor the food while cooking. These lamps are not suitable for other usage (e.g. environments lighting).

This product contains more than one light source of energy efficiency class G.

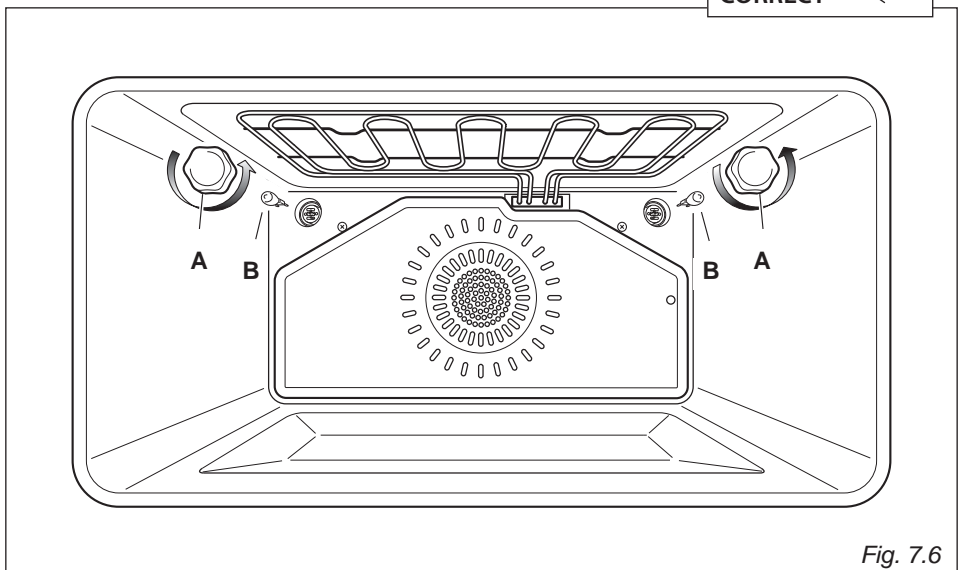
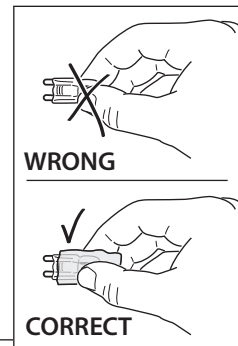

Fig. 7.6

GREASE FILTER (some models only)

- A special screen can be fitted at the back of the oven to catch grease particles, mainly when meat is being roasted (fig. 7.7).
- Slide in the grease filter on the back of the oven as in fig. 7.7.
- **Clean the filter after any cooking!**
- The grease filter can be removed for cleaning and should be washed regularly in hot soapy water. Always clean the filter after cooking as any solid residues on it might adversely affect the oven performance.
- Always dry the filter properly before fitting it back into the oven.

CAUTION: When baking pastry etc. this filter should be removed.

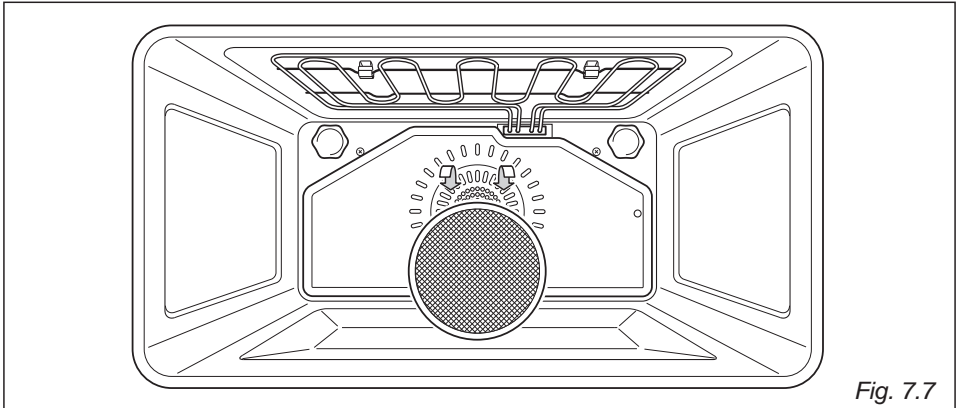

Fig. 7.7

STORAGE COMPARTMENT

The storage compartment is accessible through the pivoting panel (fig. 6.8).

Do not store flammable material in the oven or in the storage compartment.

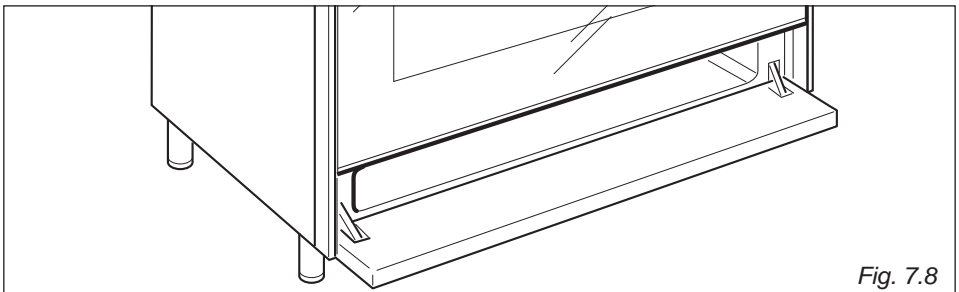

Fig. 7.8

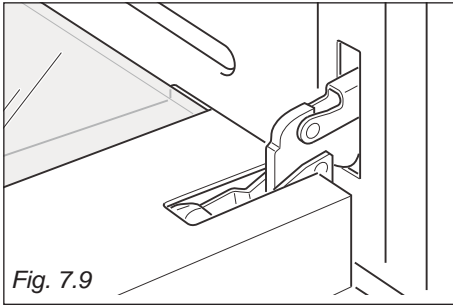

Fig. 7.9

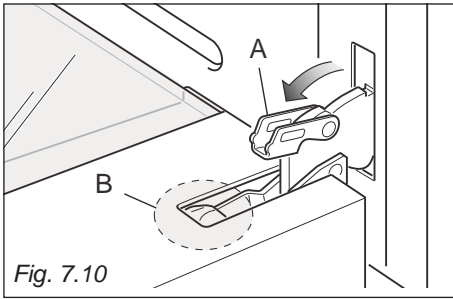

Fig. 7.10

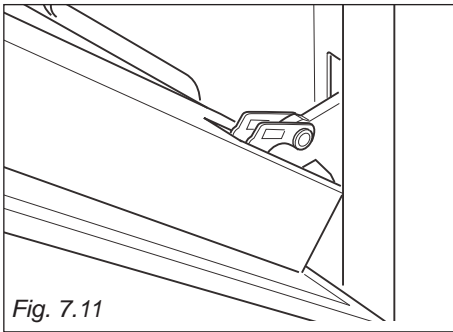

Fig. 7.11

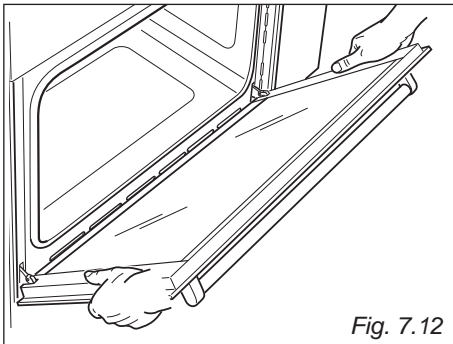

Fig. 7.12

REMOVING THE OVEN DOOR

The oven door can easily be removed as follows:

- Open the door to the full extent (fig. 7.9).
- Open the lever "A" completely on the left and right hinges (fig. 7.10).
- Hold the door as shown in fig. 7.12.
- Gently close the door (fig. 7.11) until left and right hinge levers "A" are hooked to part "B" of the door (fig. 7.10).
- Withdraw the hinge hooks from their location following arrow "C" (fig. 7.13).
- Rest the door on a soft surface.

Important!

Always keep a safe distance from the door hinges, paying special attention to position of your hands.

If the door hinges are not correctly hooked, they could unhook and close suddenly and unexpectedly with risk of injury.

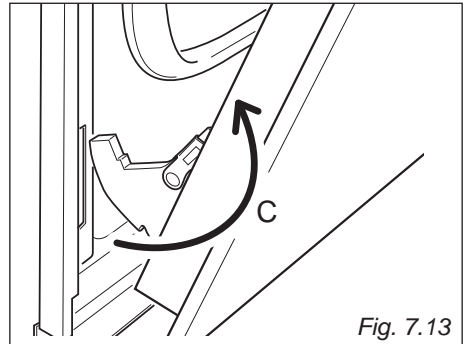
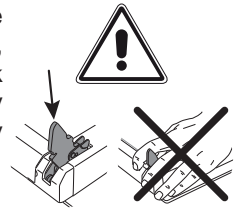
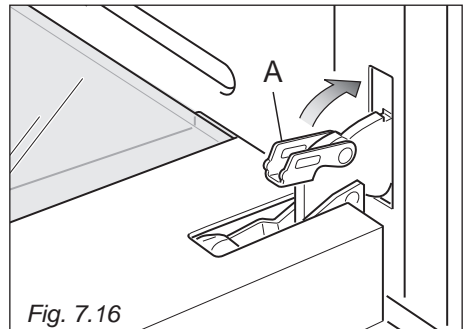
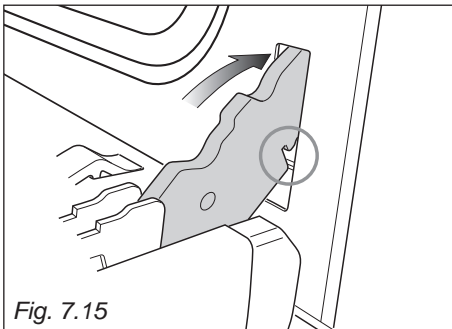
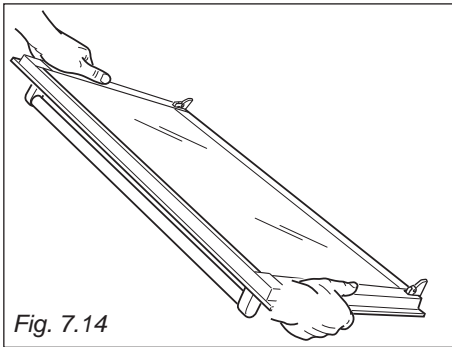

Fig. 7.13

REFIT THE DOOR

1. Hold the door firmly (fig. 7.14).
2. Insert the hinge tongues into the slots, making sure that the groove drops into place as shown in the figure 7.15.
3. Open the door to its full extent.
4. Fully close the levers "A" on the left and right hinges, as shown in the figure 7.16.
5. Close the door and check that it is properly in place.



8 - GUARANTEE

Your new “De’ Longhi” product comes with 12-month guarantee covering all parts and labour.

If your appliance proves to be defective as a result of faulty materials or workmanship during the guarantee period, these parts will be repaired or replaced free of charge.

AFTER SALES SERVICE

Should you require service, spares or product information and advice:

- Please Telephone 01908 733 010 (Great Britain)
028 9744 2461 (Northern Ireland - Mon to Fri 9:00am to 5:00pm
Excluding Bank Holidays)
 - Details of your purchase receipt will be required if you require service within the first 12-month of purchase.
1. The rights and benefits under this guarantee are additional to your statutory rights, which are not affected by this guarantee.
 2. The manufacturer undertakes within the specified period, to repair or replace free of charge any parts of the appliance found to be defective provided that:
 - We are promptly informed of the defect.
 - The appliance is installed and used in accordance with the written instructions enclosed with the appliance.
 - The appliance is used only on an electrical supply as indicated on the rating label fixed to the appliance.
 - The appliance has not been altered in any way or subject to misuse or repaired by a person other than an authorised service agent.
 3. No rights are given under this guarantee to a person acquiring the appliance second hand or for commercial, semi-commercial or communal use.
 4. This guarantee applies throughout the UK and Channel Islands.
 5. Any repaired or replacement appliances will be guaranteed on these terms for the unexpired portion of the guarantee.

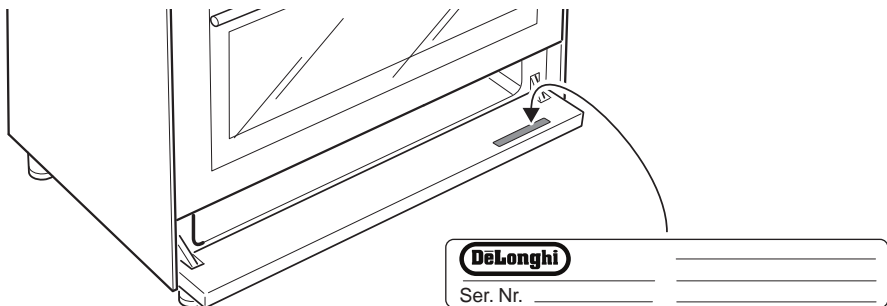

Fig. 8.1

The manufacturer cannot be held responsible for possible inaccuracies due to printing or transcription errors in the present booklet.

The manufacturer reserves the right to make all modifications to its products deemed necessary for manufacturer commercial reasons at any moment and without prior notice, without jeopardising the essential functional and safety characteristics of the appliances.

www.delonghi-cookers.co.uk

