

100Gb/s QSFP28 Active Optical Cable



Product Features

- ✓ Available in lengths of 1 to 50m on OM3 multimode fiber (MMF)
- ✓ 4 independent full-duplex channels up
- ✓ To 25Gbps data rate per wavelength
- ✓ Reliable VCSEL array technology using multimode fiber
- ✓ Hot-pluggable QSFP28 footprint
- ✓ Power dissipation: <3.5W per cable end
- ✓ Commercial operating case temperature range: 0°C to 70°C
- ✓ RoHS compliant and Lead Free
- ✓ UL certification optional cables

Applications

- ✓ IEEE 802.3bm 100GBASE SR4 and 40GBASE SR4128G Fiber Channel
- ✓ InfiniBand FDR/EDR



Regulatory Compliance

- ESD to the Electrical PINs: compatible with MIL-STD-883E Method 3015
- Immunity compatible with IEC 61000-4-3
- EMI compatible with FCC Part 15 Class B EN55022 Class B
- ROHS compliant with ROHS 2 (2011/65/EU)

Pin Descriptions

Pin	Symbol	Name	Ref.
1	GND	Ground	
2	Tx2n	Transmitter Inverted Data Input, CML-I	
3	Tx2p	Transmitter Non-Inverted Data output, CML-I	
4	GND	Ground	
5	Tx4n	Transmitter Inverted Data Input, CML-I	
6	Tx4p	Transmitter Non-Inverted Data output, CML-I	
7	GND	GND	
8	ModSelL	<p>The ModSelL is an input pin. When held low by the host, the module responds to 2-wire serial communication commands. The ModSelL allows the use of multiple QSFP+ modules on a single 2-wire interface bus. When the ModSelL is "High", the module shall not respond to or acknowledge any 2-wire interface communication from the host. ModSelL signal input node must be biased to the "High" state in the module</p>	
9	ResetL	<p>The ResetL pin must be pulled to Vcc in the QSFP+ module. A low level on the ResetL pin for longer than the minimum pulse length (t_Reset_init) initiates a complete module reset, returning all user module settings to their default state. Module Reset Assert Time (t_init) starts on the rising edge after the low level on the ResetL pin is released.</p>	

10	VccRx	+ 3.3V Power Supply Receiver
11	SCL	2-Wire Serial Interface Clock
12	SDA	2-Wire Serial Interface Data
13	GND	GND
14	Rx3p	Receiver Non-Inverted Data Output, CML-O
15	Rx3n	Receiver Inverted Data Output, CML-O
16	GND	GND
17	Rx1p	Receiver Non-Inverted Data Output, CML-O
18	Rx1n	Receiver Inverted Data Output, CML-O
19	GND	Ground
20	GND	Ground
21	Rx2n	Receiver Inverted Data Output, CML-O
22	Rx2p	Receiver Non-Inverted Data Output, CML-O
23	GND	Ground
24	Rx4n	Receiver Inverted Data Output, CML-O
25	Rx4p	Receiver Non-Inverted Data Output, CML-O
26	GND	Ground
27	ModPrsL	Module Present, connect to GND
28	IntL	The IntL pin is an open collector output and must be pulled to host supply voltage on the host board. The INTL pin is de-asserted "High" after completion of reset, when byte 2 bit 0 (Data Not Ready) is read with a value of '0' and the flag field is read.
29	VccTx	+3.3 V Power Supply transmitter
30	Vcc1	+3.3V Power Supply
31	LPMoDe	The LPMoDe pin shall be pulled up to Vcc in the QSFP+ module. This function is affected by the LPMoDe pin and the combination of the Power_over-ride and Power_set softwarecontrol bits (Address A0h, byte 93 bits 0,1).
32	GND	Ground
33	Tx3p	Transmitter Non-Inverted Data Input, CML-I
34	Tx3n	Transmitter Inverted Data Output, CML-I
35	GND	Ground
36	Tx1p	Transmitter Non-Inverted Data Input, CML-I
37	Tx1n	Transmitter Inverted Data Output, CML-I
38	GND	Ground

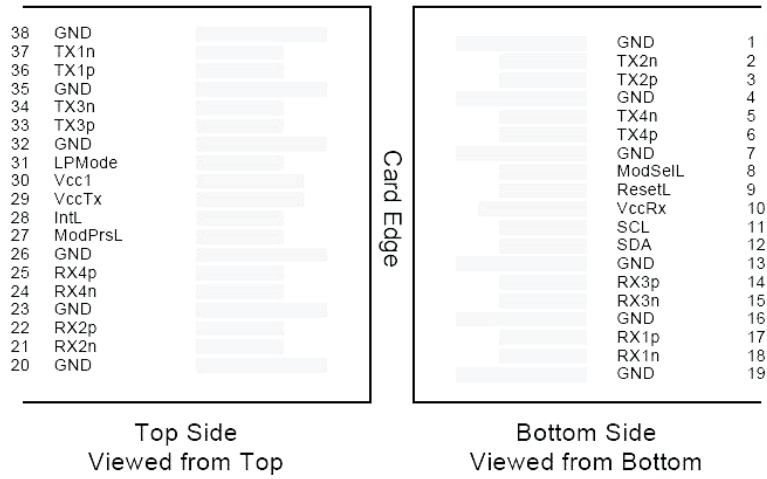

Pin-out of Connector Block on Host Board

Module Block Diagram

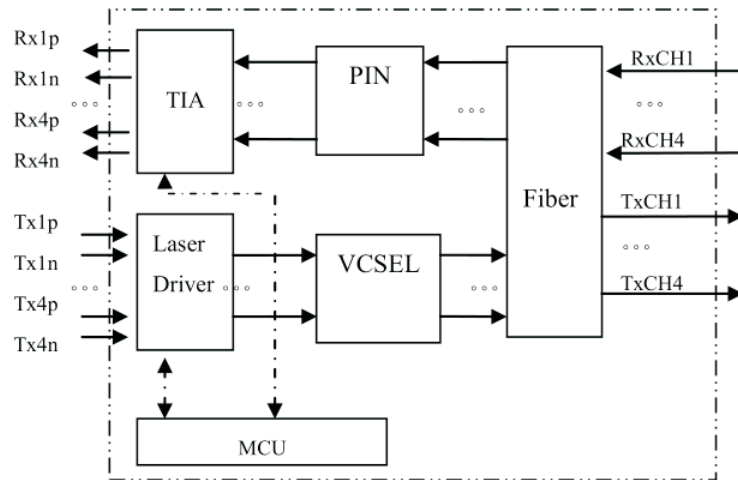

Absolute Maximum Ratings

Parameter	Symbol	Min	Typ	Max	Unit	Ref.
Maximum Supply Voltage	Vcc	-0.5		+3.6	V	
Storage Temperature	TS	-20		+85	°C	1
Operating Humidity	RH	0		85	%	2

Notes:

1. Assumes no mechanical load force on the unit. Ensuring no mechanical load force requires a cable bend radius of >105mm within 100 mm of either cable end module and >60 mm on the rest of the cable.
2. Non-condensing.

Recommended Operating Conditions

Parameter	Symbol	Min	Typ	Max	Unit	Ref.
Power Supply Voltage	Vcc	3.13	3.30	3.47	V	
Case Operating Temperature	Tc	0	-	70	°C	Commercial
Bit Rate Each Lane	Br	25.78125 ± 100pm			Gbps	
Humidity	Rh	5	-	85	%	
Fiber Bend Radius	Rb	3			cm	

Electrical Characteristics (TOP=25°C, Vcc=3.3Volts)

NOTE: The module requires an electrical connector compliant with SFF-8662 or SFF-8672 be used on the host board to guarantee its electrical interface specification. Please check with your connector supplier

Parameter	Symbol	Min	Typ	Max	Unit	Ref.
Supply Voltage	Vcc	3.15		3.45	V	
Supply Current	Icc			1010	mA	
Module total power	P			3.5	W	1, 2
Input electrical specifications (per Lane)						
Differential Voltage pk-pk				900	mV	
Differential Termination Resistance Mismatch				10	%	
Transition Time, 20 to 80%	Tr, Tf	10			Ps	
Output electrical specifications (per Lane)						
Differential Voltage pk-pk				900	mV	
Differential Termination Resistance Mismatch				10	%	
Transition Time, 20 to 80%	Tr, Tf				Ps	
Bit Error Ration	BER	10		10 ⁻¹²		3

Notes:

1. Maximum total power value is specified across the full temperature and voltage range.
2. Settable in various discrete steps via the I2C interface.
3. BER=10⁻¹²; PRBS 2³¹-1@25.78125Gbps

Mechanical Specifications

The module mechanical specifications are compliant with the QSFP28 transceiver module specifications (as defined in SFF-8661), substituting the MPO12 receptacle with a fiber optics cable connecting both ends

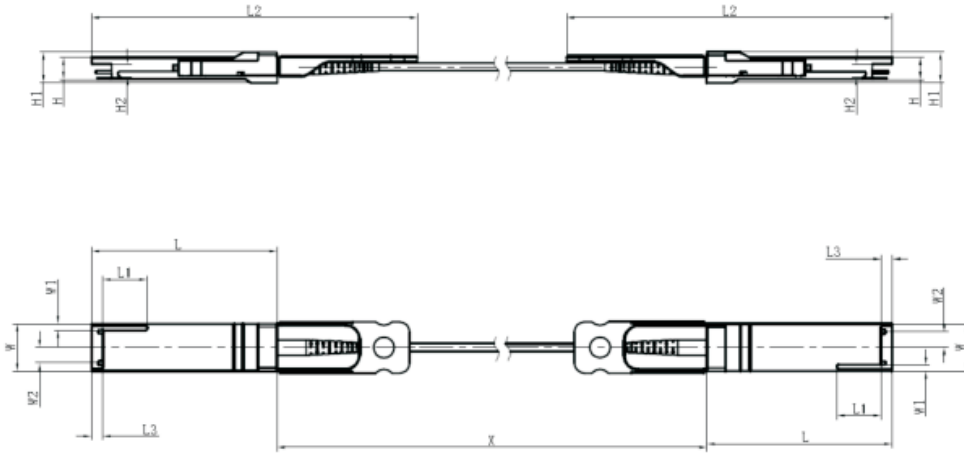

Unit: mm

	L	L1	L2	L3	W	W1	W2	H	H1	H2
MAX	72.2	—	122	4.35	18.45	—	6.2	8.6	12.0	5.35
Typical	72.0	—	—	4.20	18.35	—	—	8.5	11.8	5.2
MIN	68.8	16.5	118	4.05	18.25	2.2	5.8	8.4	11.6	5.05

Cable Length

Cable Length (Unit:m)	Tolerant (Unit:cm)
<1.0	+5/-0
1.0~4.5	+15/-0
5.0~14.5	+30/-0
≥15.0	+2%/-0