

Linux User Guide

Lenovo
ThinkStation

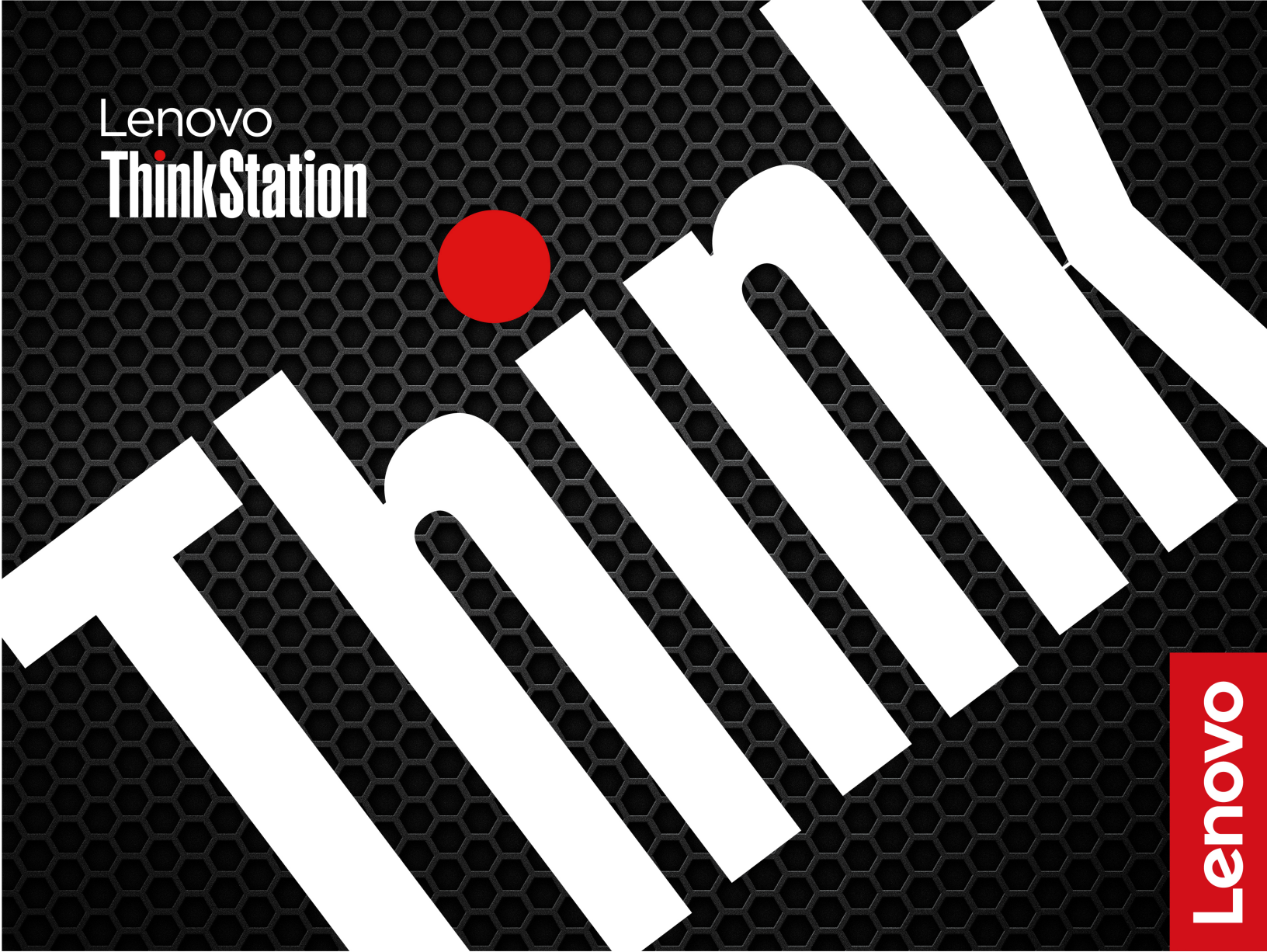

ThinkStation P3 Ultra

About this documentation

Before using this documentation, please read the following information:

- *Setup Guide*
- *Safety and Warranty Guide*
- For more compliance information, refer to *Regulatory Notice* at https://support.lenovo.com/docs/common_commercial_rn and *Generic Safety and Compliance Notices* at https://pcsupport.lenovo.com/docs/generic_notices.
- Illustrations in this documentation might look different from your product.
- Depending on the model, some optional accessories, features, software programs, and user interface instructions might not be applicable to your computer.
- Documentation content is subject to change without notice. To get the latest documentation, go to <https://support.lenovo.com/documentation>.

Fifth Edition (June 2025)

© Copyright Lenovo 2023, 2025.

LIMITED AND RESTRICTED RIGHTS NOTICE: If data or software is delivered pursuant to a General Services Administration "GSA" contract, use, reproduction, or disclosure is subject to restrictions set forth in Contract No. GS-35F-05925.

Contents

Chapter 1. Meet your computer	1
Front	1
Rear	3
Expand your computer	4
Specifications	6
USB specifications	7
Chapter 2. Get started with your computer	8
Connect an external display	8
Lock the computer	8
Get started with Ubuntu Desktop	8
Access networks	9
Connect to the wired Ethernet	9
Connect to Wi-Fi networks (for selected models)	9
Connect to a Bluetooth-enabled device (for selected models)	9
Chapter 3. Advanced configurations	11
BMC card (for selected models)	11
Set the power plan	13
UEFI BIOS passwords	14
Use BIOS security solutions	15
Wipe the storage drive data (for selected models)	15
Cover presence switch	15
Intel BIOS guard	16
Smart USB Protection	16
Absolute Persistence (for computers purchased outside mainland China)	16
What is UEFI BIOS.	16
Enter the BIOS menu.	16
Navigate in the BIOS interface	16
Change the display mode of UEFI BIOS (for selected models)	17
Set the system date and time	17
Change the boot priority order	17
Enable or disable the configuration change detection feature	18

Enable or disable the automatic power-on feature	18
Enable or disable the smart power-on feature (for selected models)	19
Change BIOS settings before installing a new operating system	19
Update UEFI BIOS.	19

Chapter 4. CRU replacement	20
CRU list	20
System board	21
Power adapter and power cord.	23
Dust filter	24
External antenna	24
Chassis	25
M.2 solid-state drive thermal kit	27
M.2 solid-state drive	28
2.5-inch hard disk drive.	29
LED cable and holder	32
System fan and its heat sink	33
Memory module	39
PCI-Express card	43

Chapter 5. Help and support	60
Self-help resources	60
Lenovo diagnostic tools	60
Call Lenovo	61
Before you contact Lenovo	61
Lenovo Customer Support Center.	61
Certification-related information	62
Purchase accessories	62
Purchase additional services.	62
Accessibility features.	62

Appendix A. Supplemental information about the Ubuntu operating system	63
---	-----------

Appendix B. Notices and trademarks.	65
--	-----------

Chapter 1. Meet your computer

Front

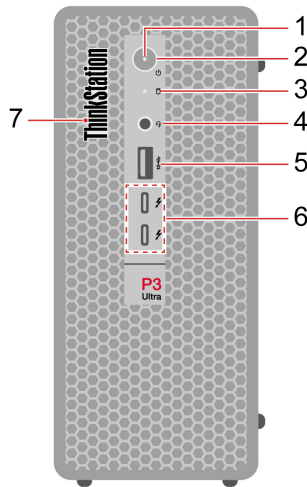

Item	Description	Item	Description
1	Power indicator	2	Power button
3	Storage drive activity indicator	4	Headset connector
5	USB-A 3.2 Gen 2 connector	6	USB-C® (Thunderbolt™ 4) connectors
7	ThinkStation® LED		

Statement on USB transfer rate

Depending on many factors such as the processing capability of the host and peripheral devices, file attributes, and other factors related to system configuration and operating environments, the actual transfer rate using the various USB connectors on this device will vary and will be slower than the data rate listed below for each corresponding device.

Note: Depending on the model, some USB connectors might not be available on your computer.

USB device	Data rate (Gbit/s)
3.2 Gen 1	5
3.2 Gen 2	10
3.2 Gen 2 × 2	20
Thunderbolt 3	40
Thunderbolt 4	40

Power indicator

Show the system status of your computer.

- **On:** The computer is starting up or working.
- **Off:** The computer is off or in hibernation mode.
- **Blinking:** The computer is in sleep mode.

Headset connector

The headset connector is compatible with:

- Headphones or earphones with a 3.5mm (0.14 inch), TRS (3-pole) plug
- Headsets with a 3.5mm (0.14 inch), CTIA-compliant TRRS (4-pole) plug

Note: This headset connector does not support standalone external microphones with a TRS (3-pole) plug or headsets with an OMTP-compliant TRRS (4-pole) plug.

Related topics

- “USB specifications” on page 7
- “Connect to a Bluetooth-enabled device” on page 9

Rear

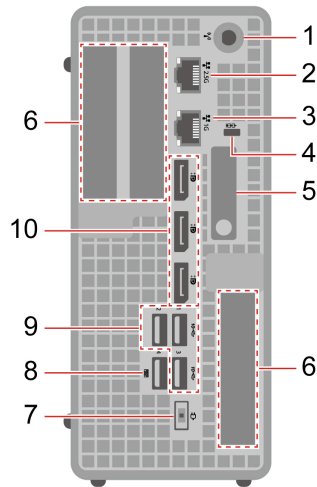

Item	Description	Item	Description
1	Wi-Fi® antenna slot	2	Ethernet connector (2.5 GbE)
3	Ethernet connector (1 GbE)	4	Security-lock slot
5	Chassis latch	6	PCI-Express card area
7	Power cord connector	8	USB-A 3.2 Gen 2 connector (smart power on)
9	USB-A 3.2 Gen 2 connectors	10	DisplayPort™ out connectors

Related topics

- “USB specifications” on page 7
- “Lock the computer” on page 8
- “Connect an external display” on page 8
- “Enable or disable the smart power-on feature (for selected models)” on page 19

Expand your computer

You can enhance your computer capacity and performance by adding various devices according to the following rules:

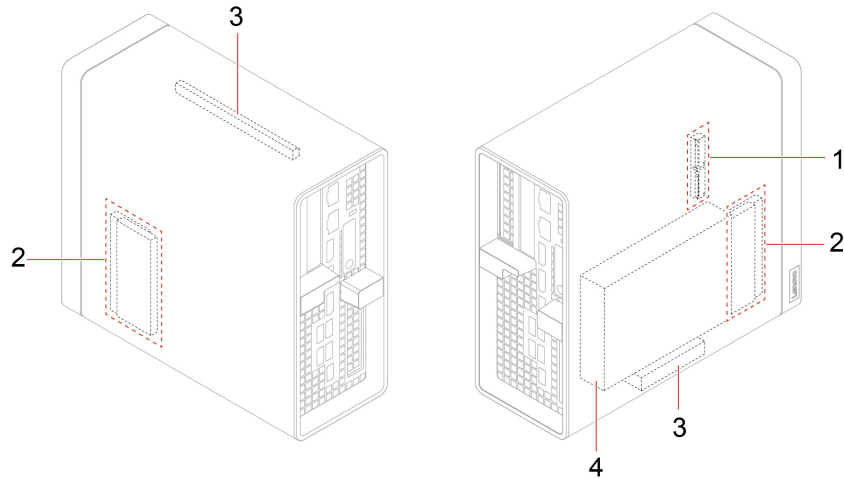

Item	Description
1. PCI-Express card slots	<p>Your computer has a PCI-Express x16 Gen 4 slot and a PCI-Express x8 Gen 3 slot. You can install the following compatible PCI-Express cards in the PCI-Express card slots:</p> <ul style="list-style-type: none"> • DisplayPort graphics card (2-port) • Mini-DisplayPort graphics card (3-port or 4-port) • USB-A 3.2 Gen 1 expansion card (2-port) • USB-C (3.2 Gen 2) expansion card (2-port) • Ethernet expansion card (2-port or 4-port) • Serial expansion card (4-port) • Baseboard Management Controller (BMC) card <p>Notes:</p> <ul style="list-style-type: none"> • The PCI-Express x16 slot is the primary slot which supports graphics card only. • The PCI-Express x8 slot is the secondary slot. You can install graphics card here when the PCI-Express x16 slot is occupied.
2. Memory slots	You can install up to four memory cards in the memory slots.
3. 2.5-inch storage drive bay*	You can install one 2.5-inch hard disk drive or one 2.5-inch solid-state drive in the storage drive bay.
4. M.2 solid-state drive slots	You can install one or two M.2 solid-state drives in the M.2 solid-state drive slots.

* for selected models

Related topics

- “PCI-Express card” on page 43
- “Memory module” on page 39
- “M.2 solid-state drive” on page 28
- “2.5-inch hard disk drive” on page 29
- “BMC card (for selected models)” on page 11

Specifications

Specifications	Description
Dimensions	<ul style="list-style-type: none">• Width: 87 mm (3.43 inches)• Height: 202 mm (7.95 inches)• Depth: 223 mm (8.78 inches)
Weight (without packaging)	Maximum configuration as shipped: 3.6 kg (7.94 lb)
Hardware configuration	<ol style="list-style-type: none">1. Open the system menu from the top-right corner and click Settings.2. Click About.
Power supply	<ul style="list-style-type: none">• 170-watt automatic voltage-sensing power supply• 230-watt automatic voltage-sensing power supply• 300-watt automatic voltage-sensing power supply
Electrical input	<ul style="list-style-type: none">• Input voltage: From 100 V ac to 240 V ac• Input frequency: 50/60 Hz
Microprocessor	To view the microprocessor information of your computer, enter Settings and click About .
Memory	Up to four double data rate 5 (DDR5) small outline dual in-line memory module (SODIMM) Maximum memory capacity: 192 GB
Storage device	<ul style="list-style-type: none">• 2.5-inch hard disk drive*• Up to two M.2 solid-state drives <p>Type Disks in the search box and use the Disks application to view the storage drive capacity of your computer.</p> <p>Note: The storage drive capacity indicated by the system is less than the nominal capacity.</p>
Network features	<ul style="list-style-type: none">• Bluetooth*• Ethernet LAN• Wireless LAN*

* for selected models

Operating environment

Maximum altitude (without pressurization)

- Operating: From 0 m (0 ft) to 3048 m (10 000 ft)
- Storage: From 0 m (0 ft) to 12192 m (40 000 ft)

Temperature

- Operating: From 10°C (50°F) to 35°C (95°F)
- Storage: From -40°C (-40°F) to 60°C (140°F)

Relative humidity

- Operating: 20%-80% (non-condensing)
- Storage: 10%–90% (non-condensing)

System memory speed





Your computer can come with the following types of memory modules and will run up to the following speed:

Memory module type	Memory module speed
DDR5 ECC 4800 SoDIMMs	4800 MT/s
DDR5 non-ECC 4800 SoDIMMs	
DDR5 ECC 5600 SoDIMMs	5600 MT/s
DDR5 non-ECC 5600 SoDIMMs	

Notes:

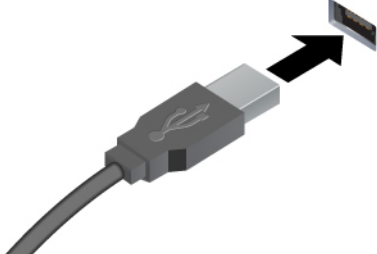
- The actual system memory speed of the memory modules varies depending on the microprocessor model. For example, your computer comes with 4800 MT/s memory modules, but the microprocessor only supports up to 4000 MT/s memory modules. Then the system memory speed will be no faster than 4000 MT/s.
- The microprocessor models supported in your computer might vary. For a list of supported microprocessor models, contact the Lenovo Customer Support Center.
- The ECC memory modules are not supported on the computer models with Intel Core i5 13400T or I3-13100 microprocessors..

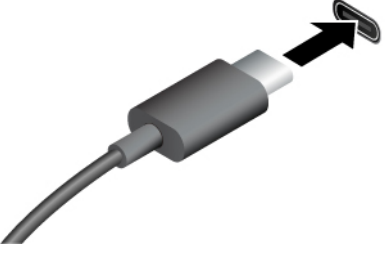
USB specifications

Connector name	Description
 <ul style="list-style-type: none">•  USB-A 3.2 Gen 2 connector	<p>Connect USB-A compatible devices, such as a USB-A keyboard, USB-A mouse, USB-A storage device, or USB-A printer.</p>
 <ul style="list-style-type: none">•  USB-C (Thunderbolt 4) connector	<ul style="list-style-type: none">• Charge USB-C compatible devices with the output voltage and current of 5V and 0.9A.• Connect to USB-C accessories to help expand your computer functionality. To purchase USB-C accessories, go to https://www.lenovo.com/accessories.

Chapter 2. Get started with your computer

Connect an external display

1. Right-click a blank area on the desktop and select display settings.
 2. Select the display that you want to configure and change display settings of your preference.
-

Lock the computer

Note: Lenovo makes no comments, judgments, or warranties about the function, quality, or performance of the locking device and security feature. You can purchase computer locks from Lenovo.

MicroSaver® lock

Lock your computer to a desk, table, or other fixtures through a MicroSaver lock.

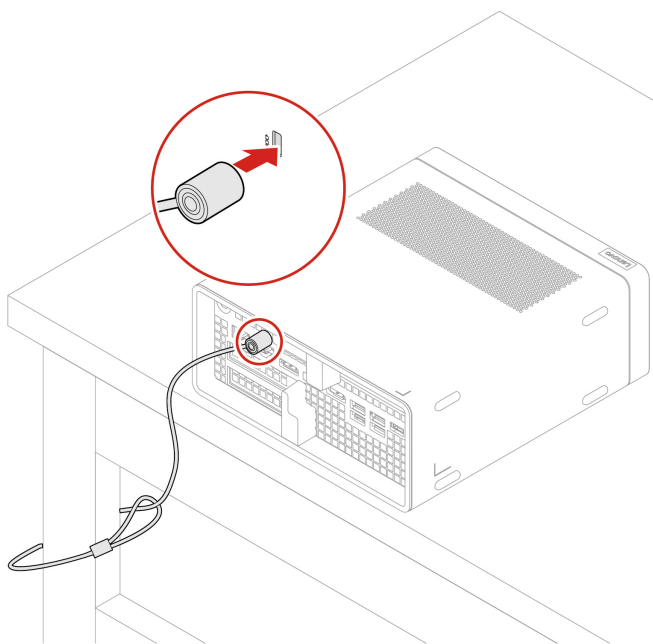

Get started with Ubuntu Desktop

Learn the basics of Ubuntu and start working with it right away. For more information about Ubuntu, see the Ubuntu documentation site at: <https://help.ubuntu.com/its/ubuntu-help/index.html>.

The Gnome desktop is installed by default and is designed to be simple and easy to use. Details on using Gnome are available by launching the Help application or online at <https://help.gnome.org/users/>.

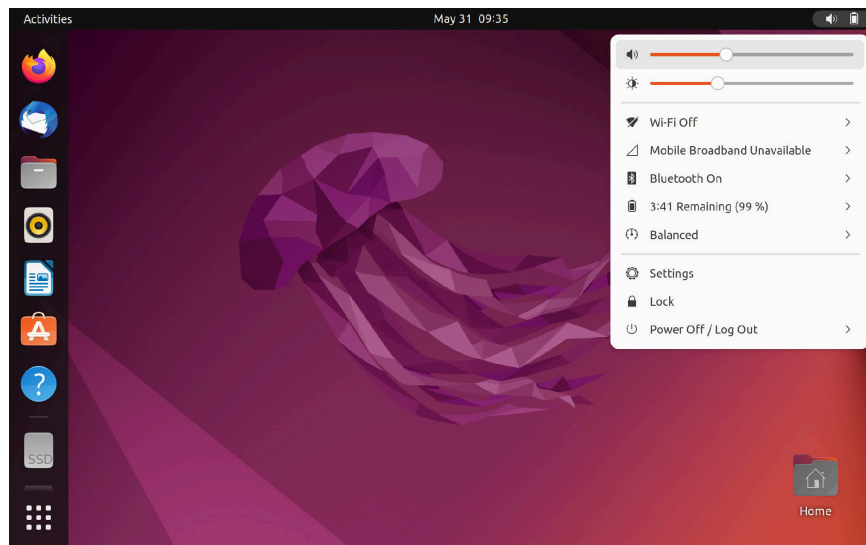

Launch an app

- Press the Super key (with the Windows logo) or open the Activities menu on the top left and type in the name of the application you want to launch.
- Click the **Show Applications** button on the lower left, and select the application you want to launch.

Launch settings

Open the system menu from the top-right corner and click **Settings**.

Access networks

This section helps you access networks through connecting to a wired or wireless network.

Connect to the wired Ethernet

Connect your computer to a local network through the Ethernet connector on your computer with an Ethernet cable.

Note: For models with an Intel X710-T2L Ethernet adapter, it's recommended to prepare a Shielded Twisted Pair (STP) Category 6A Ethernet cable for Ethernet connection on the adapter.

Connect to Wi-Fi networks (for selected models)

If your computer includes a wireless LAN module, you can connect your computer to Wi-Fi® networks.

1. Open the system menu from the top-right corner and expand the Wi-Fi section of the menu.
2. Click **Select Network**. A list of available wireless networks is displayed.
3. Select a network available for connection. Provide required information, if needed.

Connect to a Bluetooth-enabled device (for selected models)

You can connect all types of Bluetooth-enabled devices to your computer, such as a keyboard, a mouse, a smartphone, or speakers. Place the device that you are attempting to connect to less than 10 meters (33 feet) from the computer.



1. Turn on Bluetooth on the computer.
 - a. Open the system menu from the top-right corner and then click **Settings** → **Bluetooth**.
 - b. In the Bluetooth section enable Bluetooth with the toggle button at the top.
2. Any discoverable devices will be shown in the **Devices** list.
3. Select a Bluetooth device, and then follow the on-screen instructions.

Chapter 3. Advanced configurations

BMC card (for selected models)

This section provides information of the Baseboard Management Controller (BMC) card, including its functions, overview, setup, password management, and firmware update.

Functions of the BMC card

You can use the BMC card to manage your workstation through ThinkStation BMC remote management console, for example:

- View and monitor the following information:
 - Overall status
 - Relevant information of sensors
 - System inventory
- Access the following basic configurations:
 - Logs and reports
 - Configuration settings
- Access the following advanced configurations:
 - Network settings for the available LAN channels
 - Video recording
 - Remote control
 - Virtual media configuration
 - Maintenance tasks, including backing up configuration items, restoring configuration files, updating firmware, and so on.

For details of ThinkStation BMC remote management console, access the following Web site:

https://support.lenovo.com/docs/bmc_web_guide

Overview of the BMC card

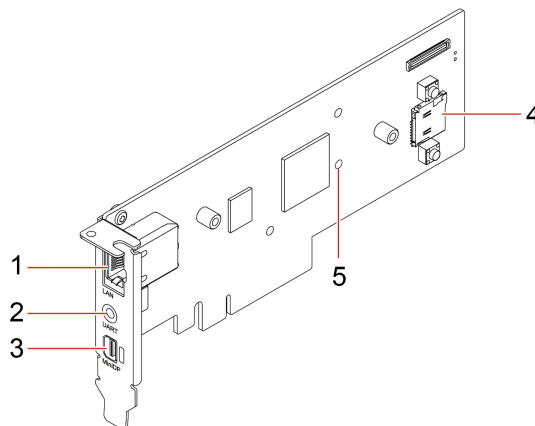





Item	Description	Item	Description
1	Ethernet connector	2	UART connector
3	Mini DisplayPort out connector	4	MicroSD slot
5	Firmware LED indicator		

Note: UART connector is disabled and reserved for future use.

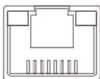
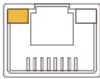
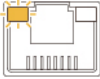
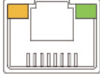
Ethernet connector

Equipped with Ethernet controllers, the Ethernet connector (RJ-45) can transfer data at a speed of 10, 100, or 1000 Mbps.

LED status	Indication
	The Ethernet is not connected yet.
	The 10-Mbps Ethernet is connected, ready for transferring data.
	The 10-Mbps Ethernet is transferring data.
	The 100-Mbps Ethernet is connected, ready for transferring data.
	The 100-Mbps Ethernet is transferring data.
	The 1000-Mbps Ethernet is connected, ready for transferring data.
	The 1000-Mbps Ethernet is transferring data.

MicroSD slot

You can install a microSD card (capacity up to 2 TB) in the microSD slot to save local data.

Firmware LED

When the LED status indicates , it means the firmware works well.

When the LED is off, it means the firmware does not work. To solve the problem, do the following:

1. Ensure that the cable is correctly connected to the BMC card and to the system board.
2. Ensure that the BMC card is correctly installed.
3. If the LED is still off, replace the BMC card with a new one.

Set up the BMC card

Do the following to set up the BMC card:

1. Install the BMC card.
2. Connect your computer to a local network with an Ethernet cable through either of the following connector:
 - The Ethernet connector on BMC card
 - The Ethernet connector (1 GbE) on the system board

Note: Ensure that the host computer and client computers are in the same local area network.

3. Connect power cables and turn on your computer. Wait at least 3 minutes for initial startup.
4. Obtain the dynamic MAC IP address (for example: 10.176.7.xxx) from either client BIOS or router port management interface, and then log in to the BMC remote management console through a web browser (for example: <https://10.176.7.xxx/#login>). For initial access, input your username (default: admin) and password (default: admin). It is recommended to change your password once you log in.

Manage the BMC password

You can manage BMC passwords in the following methods to prevent unauthorized access to your computer.

- UEFI BIOS
- The BMC remote management console
- IPMI command

Update the BMC firmware

You can update the BMC firmware to the latest depending on your needs.

1. Go to https://support.lenovo.com/docs/bmc_fw_ts_x576 and follow the on-screen instructions to select and download the corresponding firmware installation package.
2. Log in to the BMC remote management console on the host computer.
3. Click **Maintenance** → **Firmware Update** and select the latest firmware installation package you prepared. The firmware will be updated automatically. Your BMC card will automatically restart when the firmware update is completed.

Set the power plan

For ENERGY STAR® compliant computers, the following power plan takes effect when your computers have been idle for a specified duration:

- Turn off the display: After 5 minutes
- Put the computer to sleep: After 20 minutes

To awaken the computer from Sleep mode, press any key on your keyboard.

To set the power plan:

1. Go to **Settings** → **Power**.
2. Choose or customize a power plan of your preference.

UEFI BIOS passwords

You can set passwords in UEFI (Unified Extensible Firmware Interface) BIOS (Basic Input/Output System) to strengthen the security of your computer.

Password types

You can set a power-on password, supervisor password, system management password, or hard disk password in UEFI BIOS to prevent unauthorized access to your computer. However, you are not prompted to enter any UEFI BIOS password when your computer resumes from sleep mode.

- Power-on password

When a power-on password is set, you are prompted to enter a valid password each time the computer is turned on.

- Supervisor password

Setting a supervisor password deters unauthorized users from changing configuration settings. If you are responsible for maintaining the configuration settings of several computers, you might want to set a supervisor password.

When a supervisor password is set, you are prompted to enter a valid password each time you try to enter the BIOS menu.

If both the power-on password and supervisor password are set, you can enter either password. However, you must use your supervisor password to change any configuration settings.

- Hard disk password (for selected models)

Setting a hard disk password prevents unauthorized access to the data on the storage drive. When a hard disk password is set, you are prompted to enter a valid password each time you try to access the storage drive.

Note: After you set a hard disk password, your data on the storage drive is protected even if the storage drive is removed from one computer and installed in another.

- System management password (for selected models)

You can enable the system management password to have the same authority as the supervisor password to control security related features. To customize the authority of the system management password through the UEFI BIOS menu:

1. Restart the computer. When the logo screen is displayed, press F1 or Fn+F1.
2. Select **Security** → **System Management Password Access Control**.
3. Follow the on-screen instructions.

If you have set both the supervisor password and the system management password, the supervisor password overrides the system management password.

Set, change, and remove a password

Before you start, print these instructions.

1. Restart the computer. When the logo screen is displayed, press F1 or Fn+F1.
2. Select **Security**.
3. Depending on the password type, select **Set Supervisor Password**, **Set Power-On Password**, **Set System Management Password**, or **Hard Disk Password** and press Enter.
4. Follow the on-screen instructions to set, change, or remove a password.
5. Press F10 or Fn+F10 to save the changes and exit.

You should record your passwords and store them in a safe place. If you forget the passwords, contact a Lenovo-authorized service provider.

Note: If the hard disk password is forgotten, Lenovo cannot remove the password or recover data from the storage drive.

Use BIOS security solutions

This section provides BIOS solutions to secure your computer and information.

Wipe the storage drive data (for selected models)

It is recommended that you wipe the storage drive data before recycling the storage drive or the computer.

To wipe the storage drive data:

1. Restart the computer. When the logo screen is displayed, press F1 or Fn+F1.
2. Select **Security** → **secure wipe** → **Enabled**.
3. Press F10 or Fn+F10 to save the changes and exit.
4. Restart the computer. When the logo screen is displayed, press F12 or Fn+F12.
5. Select **App Menu** → **secure wipe** and press Enter.
6. Select the storage drive you will wipe and click **NEXT**.
7. Select the entire storage drive or partition to wipe as desired.
8. Select the method as desired and click **NEXT**.
9. Click **Yes** to confirm your option when the prompting window is displayed.
10. If you have set a hard disk password for the storage drive, enter the password. Otherwise, set a temporary password following the on-screen instructions. Then, click **NEXT**. The wiping process begins.

Note: Duration of the wiping process varies depending on the storage drive capacity.

11. Click **Reboot** when you are prompted to reset the system, and then one of the following will happen:
 - If the system storage drive data is wiped, you will be prompted that no operating system is found.
 - If the non-system storage drive data is wiped, the computer restarts automatically.

Cover presence switch

The cover presence switch prevents the computer from logging in to the operating system when the computer cover is not properly installed or closed.

To enable or disable the cover presence switch connector on the system board:

1. Restart the computer. When the logo screen is displayed, press F1 or Fn+F1.
2. Select **Security** → **Cover Tamper Detected** and press Enter.
3. Select **Enabled** or **Disabled** and press Enter.
4. Press F10 or Fn+F10 to save the changes and exit.

If the cover presence switch is enabled and the computer cover is not correctly installed or closed, an error message will be displayed when you turn on the computer. To bypass the error message and log in to the operating system, properly install and close the computer cover, and then enable the cover presence switch connector again in the BIOS menu.

Intel BIOS guard

The Intel BIOS Guard module cryptographically verifies all BIOS updates. This hardware-based security helps prevent software and malware attacks on the computers BIOS.

Smart USB Protection

The Smart USB Protection function is a security function that helps prevent data from being copied from the computer to USB storage devices connected to the computer. You can set the Smart USB Protection function to one of the following modes:

- **Disabled** (default setting): You can use the USB storage devices without limitation.
- **Read Only**: You cannot copy data from the computer to the USB storage devices. However, you can access data on the USB storage devices.
- **No Access**: You cannot access the USB storage devices from the computer.

To configure the Smart USB Protection function:

1. Restart the computer. When the logo screen is displayed, press F1 or Fn+F1.
2. Select **Security** → **Smart USB Protection** and press Enter.
3. Select the desired setting and press Enter.
4. Press F10 or Fn+F10 to save the changes and exit.

Absolute Persistence (for computers purchased outside mainland China)

Absolute Persistence technology is embedded in BIOS. It detects changes that happen on the hardware, software, or the call-in location. It keeps you always knowing what condition the computer is in. To activate the technology, you have to purchase a subscription to Absolute.

What is UEFI BIOS

Note: The operating system settings might override any similar settings in UEFI BIOS.

UEFI BIOS is the first program that the computer runs when the computer is turned on. UEFI BIOS initializes the hardware components and loads the operating system and other programs. Your computer comes with a setup program with which you can change UEFI BIOS settings.

Enter the BIOS menu

Restart the computer. When the logo screen is displayed, press F1 or Fn+F1 to enter the BIOS menu.

Note: If you have set BIOS passwords, enter the correct passwords when prompted. You also can select **No** or press Esc to skip the password prompt and enter the BIOS menu. However, you cannot change the system configurations that are protected by passwords.

Navigate in the BIOS interface

Attention: The default configurations are already optimized for you in **boldface**. Improper change of the configurations might cause unexpected results.

Depending on your keyboard, you can navigate in the BIOS interface by pressing the following keys, or combinations of Fn and the following keys:

Key	Function
F1 or Fn+F1	General Help
Esc or Fn+Esc	Exit the submenu
↑ ↓ or Fn+↑ ↓	Locate an item
← → or Fn+← →	Move keyboard focus
+/- or Fn+ +/-	Change value
Enter	Enter the submenu
F9 or Fn+F9	Setup Defaults
F10 or Fn+F10	Save and exit

Change the display mode of UEFI BIOS (for selected models)

You can use UEFI BIOS in the graphic mode or the text mode according to your needs.

The keys on the keyboard used to perform various tasks are displayed at the bottom of the screen. In addition to the keyboard, you also can use the mouse to make selections.

To change the display mode of UEFI BIOS:

1. Restart the computer. When the logo screen is displayed, press F1 or Fn+F1.
2. Select **Main → Setup Mode Select** and press Enter.
3. Set the display mode as desired.

Set the system date and time

1. Restart the computer. When the logo screen is displayed, press F1 or Fn+F1.
2. Select **Main → System Time & Date** and press Enter.
3. Set the system date and time as desired.
4. Press F10 or Fn+F10 to save the changes and exit.

Change the boot priority order

If the computer does not boot from a device as expected, you can change the boot priority order permanently or select a temporary boot device.

Change the boot priority order permanently

1. Depending on the type of the storage device, do one of the following:
 - If the storage device is internal, go to step 2.
 - If the storage device is a disc, ensure that the computer is on or turn on the computer. Then, insert the disc into the optical drive.
 - If the storage device is an external device other than a disc, connect the storage device to the computer.
2. Restart the computer. When the logo screen is displayed, press F1 or Fn+F1.
3. Select **Startup → Boot Priority Order**, and then follow the on-screen instructions to change the boot priority order.

4. You can also select the first priority device group by selecting **Startup → First Boot Device**, and then follow the on-screen instructions to select the first boot device within this group. Your computer will boot from the first boot device before trying the boot priority order you set in the previous step.
5. Press F10 or Fn+F10 to save the changes and exit.

Select a temporary boot device

Note: Not all discs and storage drives are bootable.

1. Depending on the type of the storage device, do one of the following:
 - If the storage device is internal, go to step 2.
 - If the storage device is a disc, ensure that the computer is on or turn on the computer. Then, insert the disc into the optical drive.
 - If the storage device is an external device other than a disc, connect the storage device to the computer.
2. Restart the computer. When the logo screen is displayed, press F12 or Fn+F12.
3. Select the storage device as desired and press Enter.

If you want to change the boot priority order permanently, select **Enter Setup on Startup Device Menu** and press Enter to enter the BIOS menu.

Enable or disable the configuration change detection feature

If you enable configuration change detection, when the POST detects configuration changes of some hardware devices (such as storage drives or memory modules), an error message will be displayed when you turn on the computer.

To enable or disable the configuration change detection feature:

1. Restart the computer. When the logo screen is displayed, press F1 or Fn+F1.
2. Select **Security → Configuration Change Detection** and press Enter.
3. Enable or disable the feature as desired.
4. Press F10 or Fn+F10 to save the changes and exit.

To bypass the error message and log in to the operating system, press F2 or Fn+F2. To clear the error message, enter the BIOS menu, save and then exit.

Enable or disable the automatic power-on feature

The Automatic Power On item in UEFI BIOS provides various options for you to make your computer start up automatically.

To enable or disable the automatic power-on feature:

1. Restart the computer. When the logo screen is displayed, press F1 or Fn+F1.
2. Select **Power → Automatic Power On** and press Enter.
3. Select the feature as desired and press Enter.
4. Enable or disable the feature as desired.
5. Press F10 or Fn+F10 to save the changes and exit.

Enable or disable the smart power-on feature (for selected models)

Ensure that the keyboard is connected to a USB connector supporting the smart power-on feature. With the smart power-on feature enabled, you can start up or wake up the computer from the hibernation mode by pressing Alt+P.

To enable or disable the smart power-on feature:

1. Restart the computer. When the logo screen is displayed, press F1 or Fn+F1.
2. Select **Power** → **Smart Power On** and press Enter.
3. Enable or disable the feature as desired.
4. Press F10 or Fn+F10 to save the changes and exit.

Change BIOS settings before installing a new operating system

BIOS settings vary by operating system. Change the BIOS settings before installing a new operating system.

To change the BIOS settings:

1. Restart the computer. When the logo screen is displayed, press F1 or Fn+F1.
2. From the main interface, select **Security** → **Secure Boot** and press Enter.
3. Depending on the operating system to be installed, do one of the following:
 - To install the Windows 10 (64-bit) and most of Linux operating system, select **Enabled** for **Secure Boot**.
 - To install an operating system that does not support secure boot, select **Disabled** for **Secure Boot**.
4. Press F10 or Fn+F10 to save the changes and exit.

Update UEFI BIOS

When you install a new program, device driver, or hardware component, you might need to update UEFI BIOS. You can update the BIOS from your operating system or a flash update disc (supported only on selected models).

Download and install the latest UEFI BIOS update package by one of the following methods:

- Using the built-in software update service:
 - For Ubuntu operating system, Ubuntu software update will check the LVFS site for any firmware updates and notify you when updates are available.
 - For IGEL operating system, update, downgrade, or reinstall the UEFI BIOS using the IGEL Universal Management Suite (UMS). See [Universal Firmware Update in the IGEL UMS](#).
- From the Lenovo Support Web site:
 1. Go to <https://pcsupport.lenovo.com>.
 2. Download the flash BIOS update driver for the operating system version or the ISO image version (used to create a flash update disc). Then, download the installation instructions for the flash BIOS update driver you have downloaded.
 3. Print the installation instructions and follow the instructions to update the BIOS.

Chapter 4. CRU replacement

Customer Replaceable Units (CRUs) are parts that can be replaced by the customer. Lenovo computers contain the following types of CRUs:

- **Self-service CRUs:** Refer to parts that can be replaced easily by customer themselves or by trained service technicians at an additional cost.
- **Optional-service CRUs:** Refer to parts that can be replaced by customers with a greater skill level. Trained service technicians can also provide service to replace the parts under the type of warranty designated for the customer's machine.

If you intend on installing the CRU, Lenovo will ship the CRU to you. CRU information and replacement instructions are shipped with your product and are available from Lenovo at any time upon request. You might be required to return the defective part that is replaced by the CRU. When return is required: (1) return instructions, a prepaid shipping label, and a container will be included with the replacement CRU; and (2) you might be charged for the replacement CRU if Lenovo does not receive the defective CRU within thirty (30) days of your receipt of the replacement CRU. For full details, see the Lenovo Limited Warranty documentation at:

https://www.lenovo.com/warranty/llw_02

CRU list

The following is the CRU list of your computer.

Self-service CRUs

- 2.5-inch hard disk drive*
- 2.5-inch hard disk drive bracket*
- 2.5-inch hard disk drive cable*
- ac power adapter
- Chassis
- Dust filter*
- External antenna
- Keyboard*
- Memory
- Mouse*
- M.2 solid-state drive
- M.2 solid-state drive thermal kit with thermal pad
- PCI-Express card bracket
- Power cord

Optional-service CRUs

- LED cable
- LED cable holder
- PCI-Express card
- PCI-Express card holder*
- PCI-Express card converter

- Rear USB 3.2 Gen 2x2 Type-C PCI-Express x4 adapter
- System fan and heat sink
- Thermal heat sink and fan for Type-5 PCI-Express card*

* for selected models

System board

Note: The system board might look slightly different from the illustration.

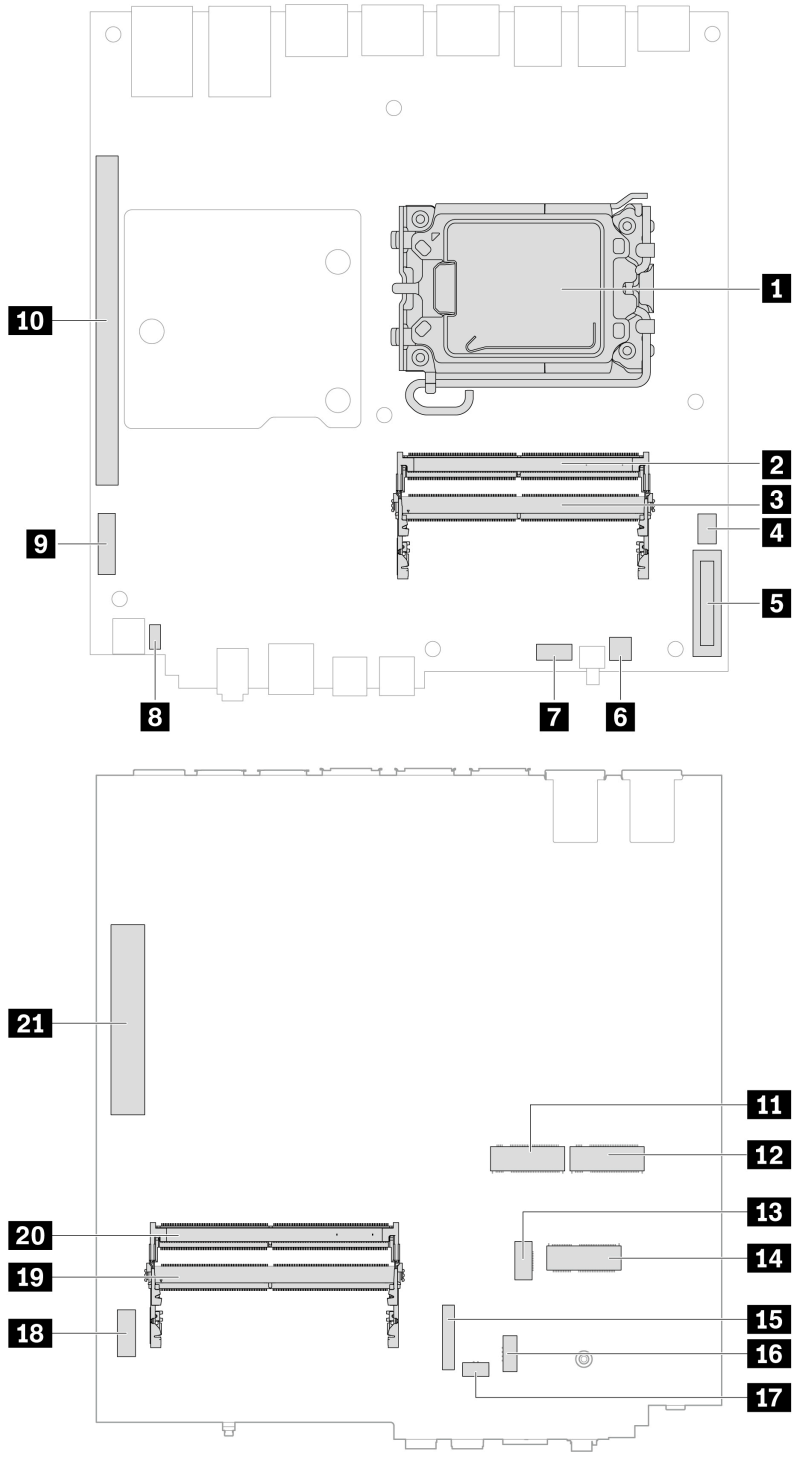

Figure 1. System board part locations

Item	Item
1 Microprocessor	2 Memory slot (SODIMM 1)
3 Memory slot (SODIMM 3)	4 System fan connector

Item	Item
5 Coin-cell battery	6 Clear CMOS/Recovery jumper
7 Auxiliary fan connector 1	8 Internal speaker connector
9 Power connector for PCI-Express x16 card	10 PCI-Express x16 card slot
11 M.2 solid-state drive slot 2	12 M.2 solid-state drive slot 1
13 M.2 fan connector	14 M.2 Wi-Fi card slot
15 BMC connector	16 Auxiliary fan connector 2
17 ThinkStation LED connector	18 5G HDR connector
19 Memory slot (SODIMM 4)	20 Memory slot (SODIMM 2)
21 PCI-Express x8 card slot	

Power adapter and power cord

Prerequisite

Before you start, read *Generic Safety and Compliance Notices*, and print the following instructions.

For access, turn off the computer and remove all connected devices and cables.

Removal steps

1. Remove the power adapter.

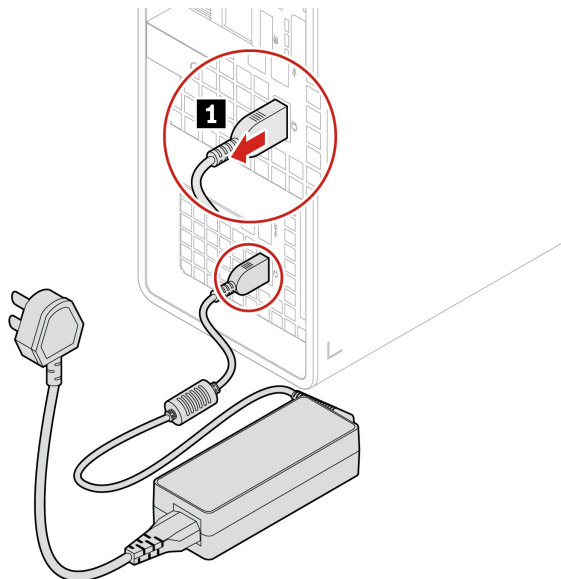

2. Remove the power cord.

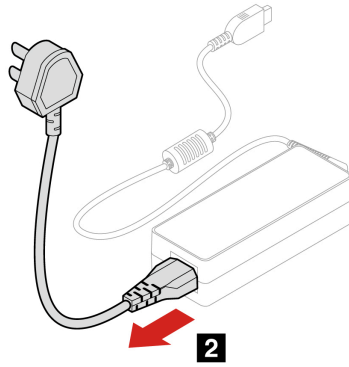

Dust filter

Prerequisite

Before you start, read *Generic Safety and Compliance Notices*, and print the following instructions.

For access, turn off the computer and remove all cables and devices connected to the front bezel.

Removal steps

Remove the dust filter.

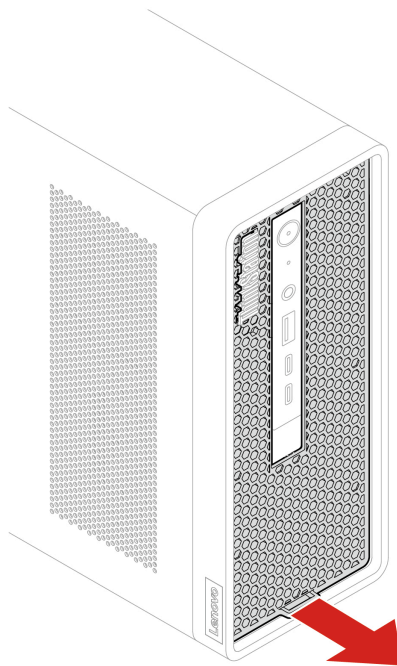

External antenna

Prerequisite

Before you start, read *Generic Safety and Compliance Notices*, and print the following instructions.

For access, turn off the computer and remove all connected devices and cables.

Removal steps

Remove the antenna.

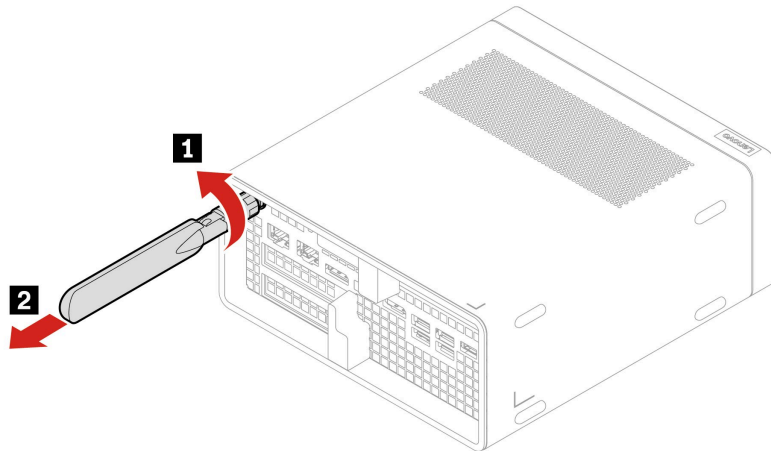

Installation steps

Install the antenna.

Note: Once the Wi-Fi antenna is installed, you can turn the antenna clockwise or counter-clockwise to 90° maximum.

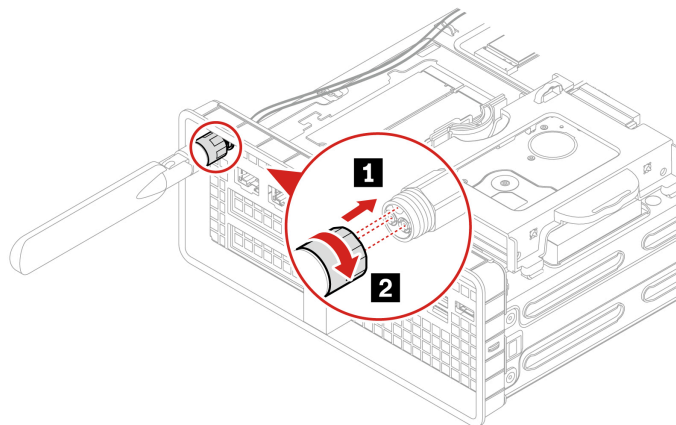

Chassis

Prerequisite

Before you start, read *Generic Safety and Compliance Notices*, and print the following instructions.



Before you remove the chassis, turn off the computer and wait several minutes until the computer is cool.

For access, do the following:

1. Turn off the computer and remove all connected devices and cables.
2. Disconnect the computer from ac power and all connected cables.
3. Unlock any locking device that secures the chassis.

Removal steps

1. Push and open the chassis latches.

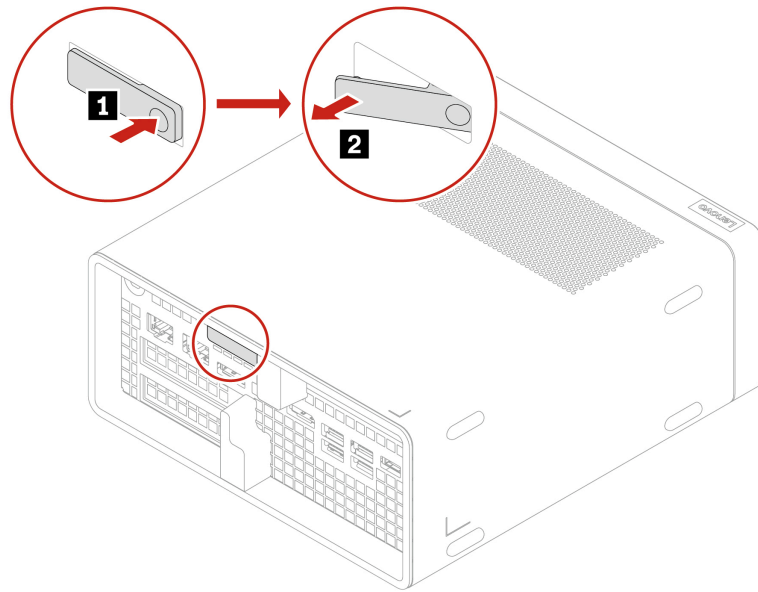

2. Remove the chassis.

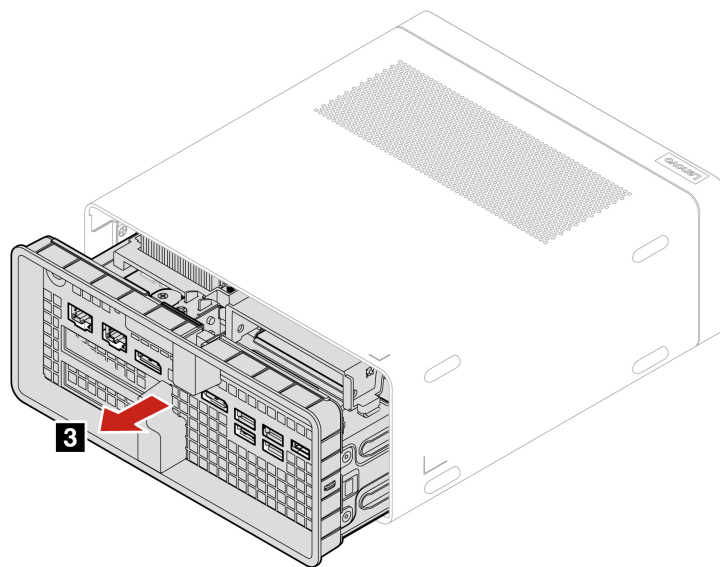

Installation steps

Install the chassis.

Note: Push the parts into place until you hear a clicking sound.

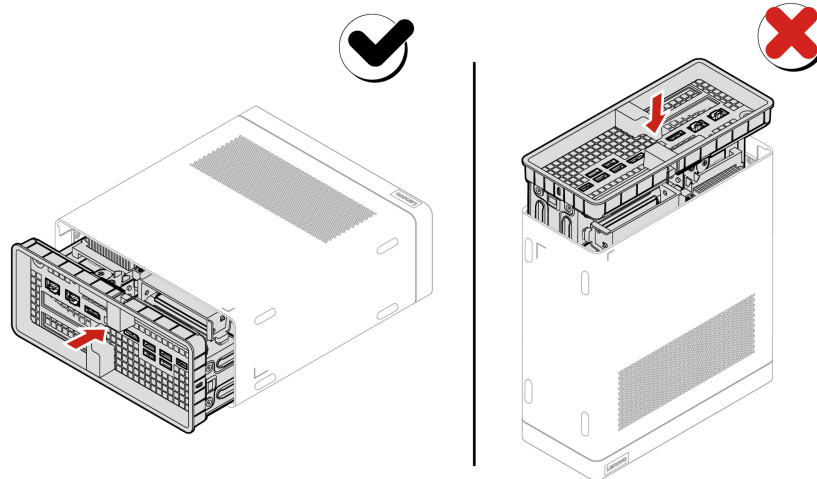

M.2 solid-state drive thermal kit

Prerequisite

Before you start, read *Generic Safety and Compliance Notices*, and print the following instructions.



The thermal kit might be very hot. Before you open the chassis, turn off the computer and wait several minutes until the computer is cool.

For access, do the following:

1. Remove the power adapter and cord. See “Power adapter and power cord” on page 23.
2. Remove the chassis. See “Chassis” on page 25.
3. Disconnect the power cable from the thermal kit.

Removal steps

Remove the M.2 solid-state drive thermal kit.

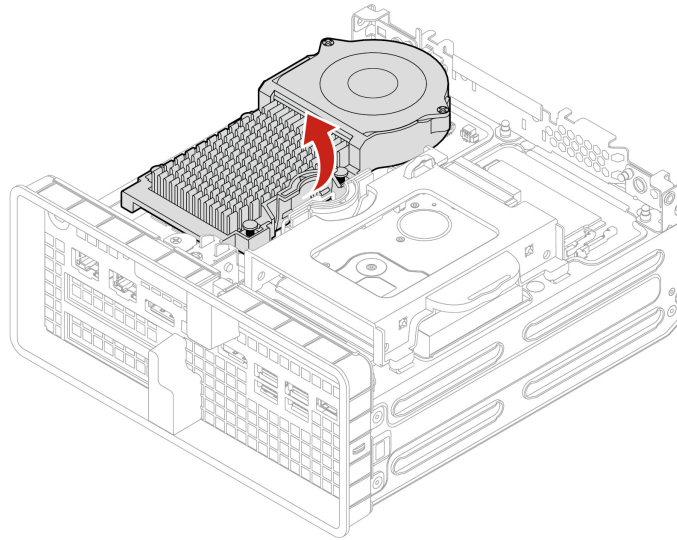

Installation steps

Install the M.2 solid-state drive thermal kit.

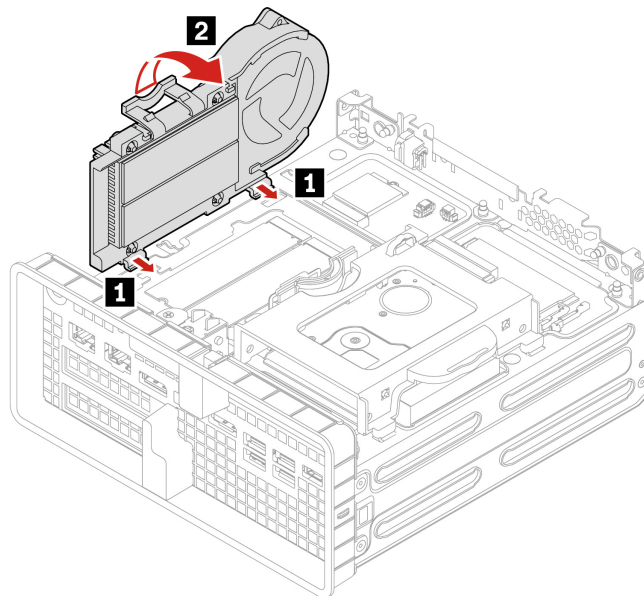

M.2 solid-state drive

Prerequisite

Before you start, read *Generic Safety and Compliance Notices*, and print the following instructions.



The thermal kit might be very hot. Before you open the chassis, turn off the computer and wait several minutes until the computer is cool.

Attention: The internal storage drive is sensitive. Inappropriate handling might cause damage and permanent loss of data. When handling the internal storage drive, observe the following guidelines:

- Replace the internal storage drive only for repair. The internal storage drive is not designed for frequent changes or replacement.
- Before replacing the internal storage drive, make a backup copy of all the data that you want to keep.
- Do not touch the contact edge of the internal storage drive. Otherwise, the internal storage drive might get damaged.
- Do not apply pressure to the internal storage drive.
- Do not make the internal storage drive subject to physical shocks or vibration. Put the internal storage drive on a soft material, such as cloth, to absorb physical shocks.

For access, do the following:

1. Remove the power adapter and cord. See “Power adapter and power cord” on page 23.
2. Remove the chassis. See “Chassis” on page 25.
3. Remove the M.2 solid-state drive thermal kit with thermal pad. See “M.2 solid-state drive thermal kit” on page 27.

Removal steps

Remove the M.2 solid-state drive.

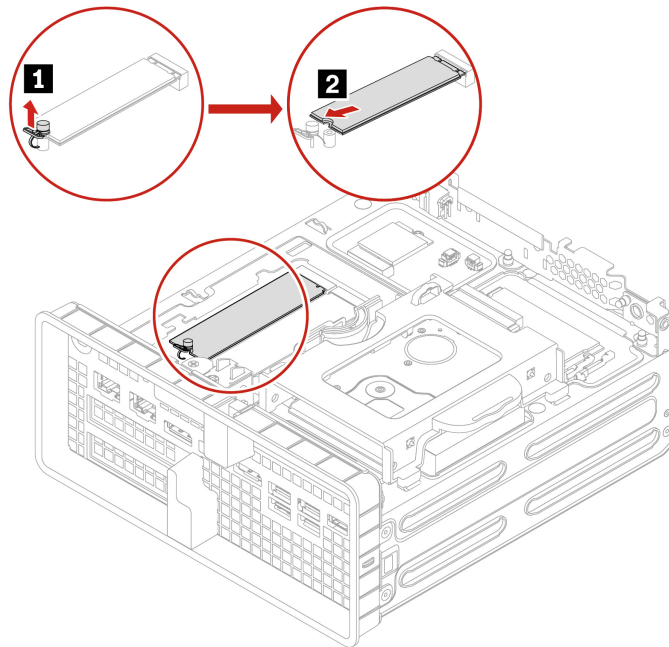

2.5-inch hard disk drive

Prerequisite

Before you start, read *Generic Safety and Compliance Notices*, and print the following instructions.

Attention: The internal storage drive is sensitive. Inappropriate handling might cause damage and permanent loss of data. When handling the internal storage drive, observe the following guidelines:

- Replace the internal storage drive only for repair. The internal storage drive is not designed for frequent changes or replacement.
- Before replacing the internal storage drive, make a backup copy of all the data that you want to keep.
- Do not touch the contact edge of the internal storage drive. Otherwise, the internal storage drive might get damaged.
- Do not apply pressure to the internal storage drive.
- Do not make the internal storage drive subject to physical shocks or vibration. Put the internal storage drive on a soft material, such as cloth, to absorb physical shocks.

For access, do the following:

1. Remove the power adapter and cord. See “Power adapter and power cord” on page 23.
2. Remove the chassis. See “Chassis” on page 25.
3. Remove the M.2 solid-state drive thermal kit with thermal pad. See “M.2 solid-state drive thermal kit” on page 27.
4. Disconnect the signal cable and the power cable from the storage drive.

Removal steps

1. Remove the storage drive bracket.

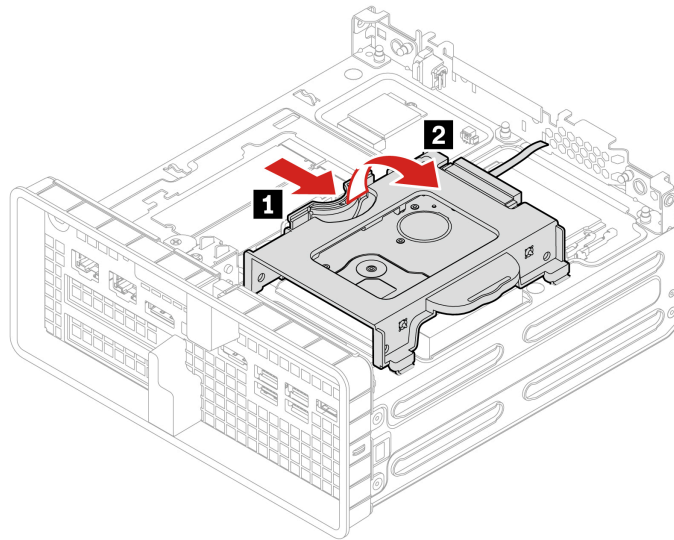

2. Remove the storage drive from the bracket.

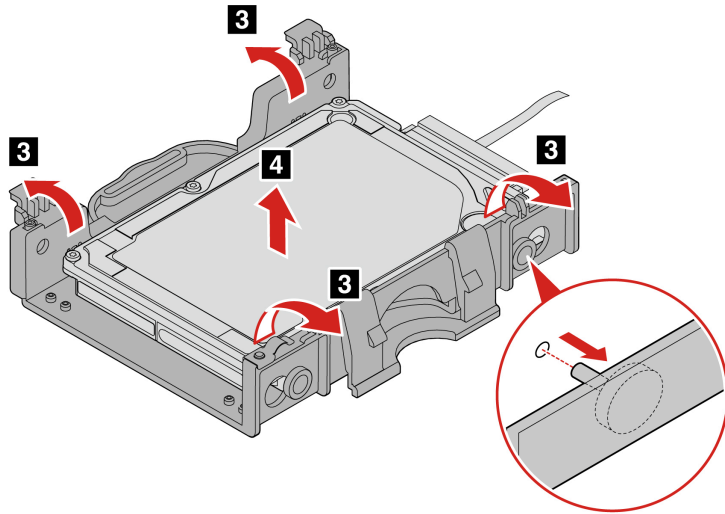

Installation steps

1. Install the storage drive to the bracket.

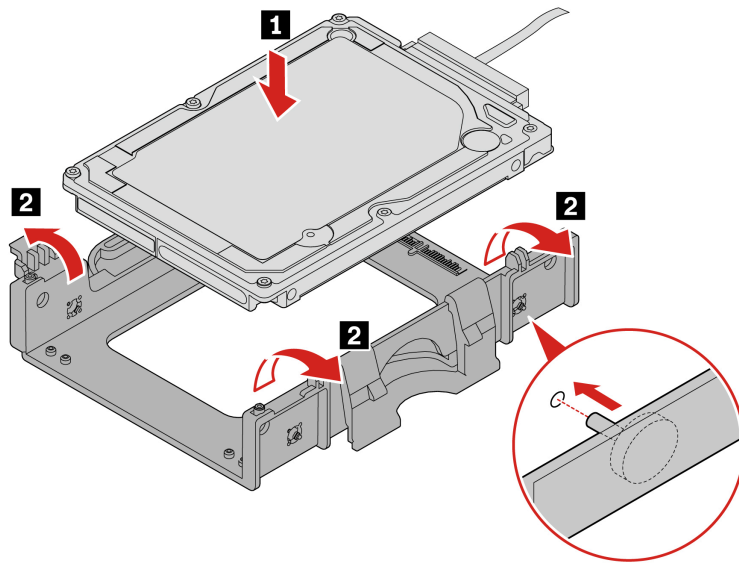

2. Install the storage drive bracket.

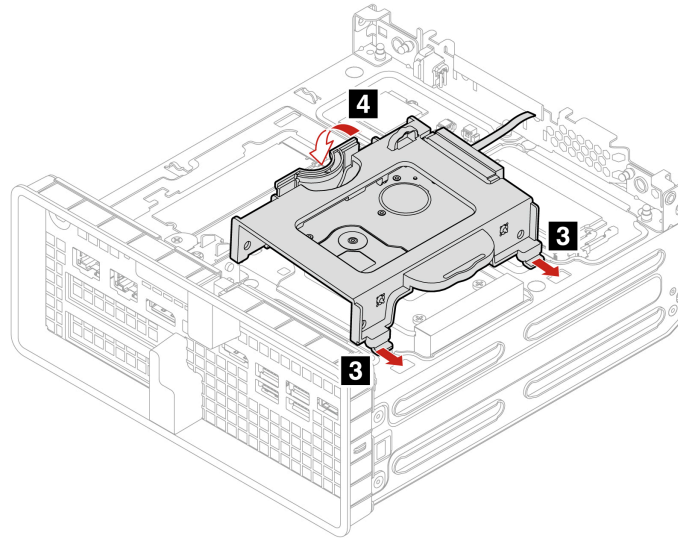

LED cable and holder

Prerequisite

Before you start, read *Generic Safety and Compliance Notices*, and print the following instructions.



The LED cable and holder be very hot. Before you open the chassis, turn off the computer and wait several minutes until the computer is cool.

For access, do the following:

1. Remove the power adapter and cord. See “Power adapter and power cord” on page 23.
2. Remove the chassis. See “Chassis” on page 25.

Removal steps

1. Remove the LED holder.

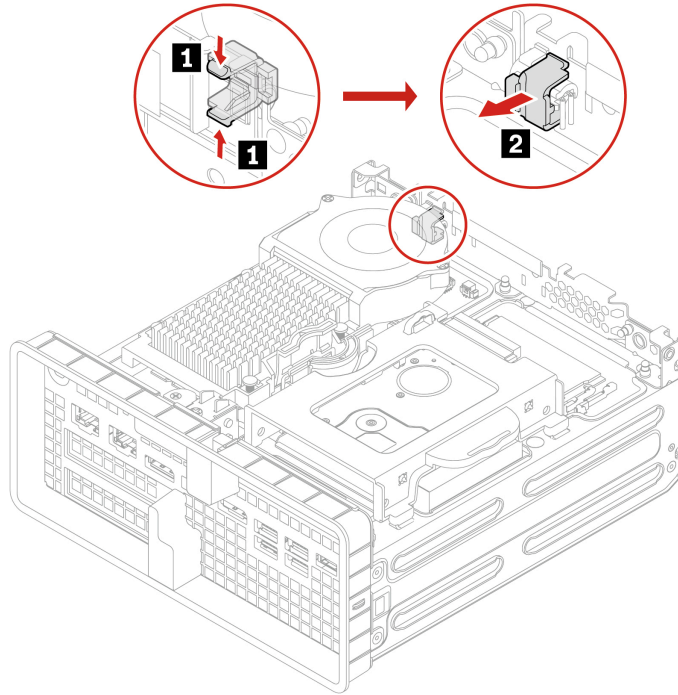

2. Remove the LED cable.

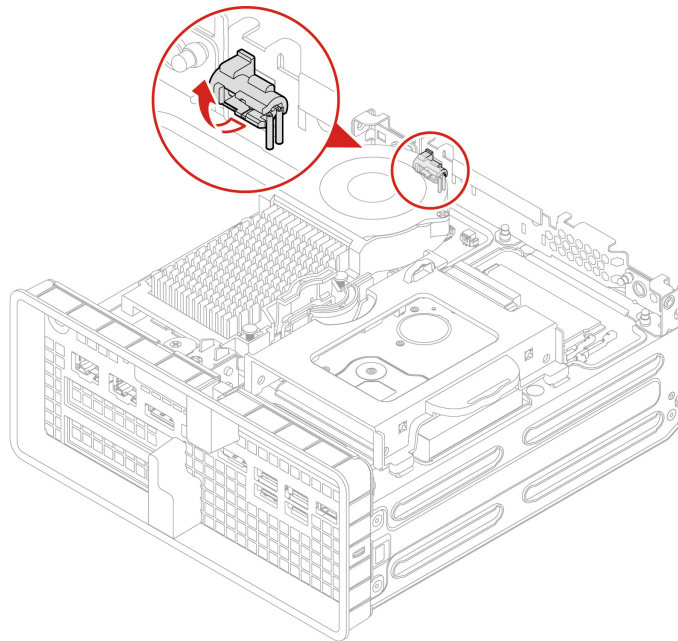

System fan and its heat sink

Prerequisite

Before you start, read *Generic Safety and Compliance Notices*, and print the following instructions.



The system fan and heat sink be very hot. Before you open the chassis, turn off the computer and wait several minutes until the computer is cool.

For access, do the following:

1. Remove the power adapter and cord. See “Power adapter and power cord” on page 23.
2. Remove the chassis. See “Chassis” on page 25.
3. Disconnect the power cable from the system board.

65-watt system fan

Removal steps:

1. Release the system fan latch and lift the system fan up.

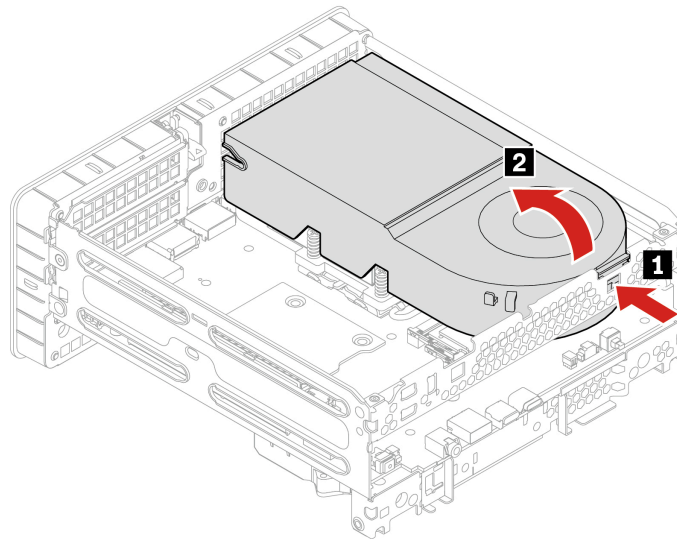

2. Loosen the heat sink screws and remove the heat sink with system fan.

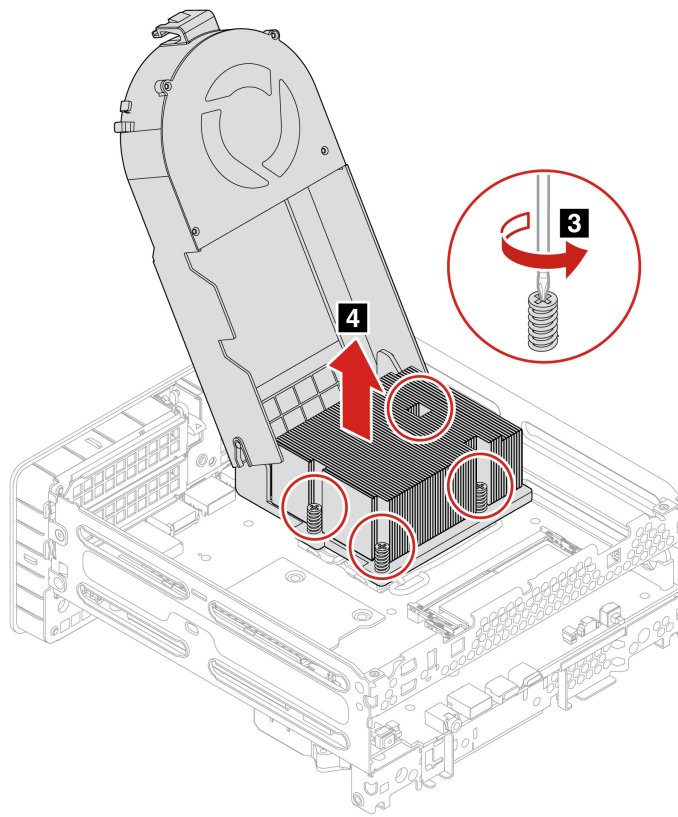

Step	Screw (quality)	Color	Torque
E	M3 x L17.8 mm, flat-head (4)	Bright Ni	3.0±0.1 in-lbs

Installation steps:

1. Secure the heat sink screws.

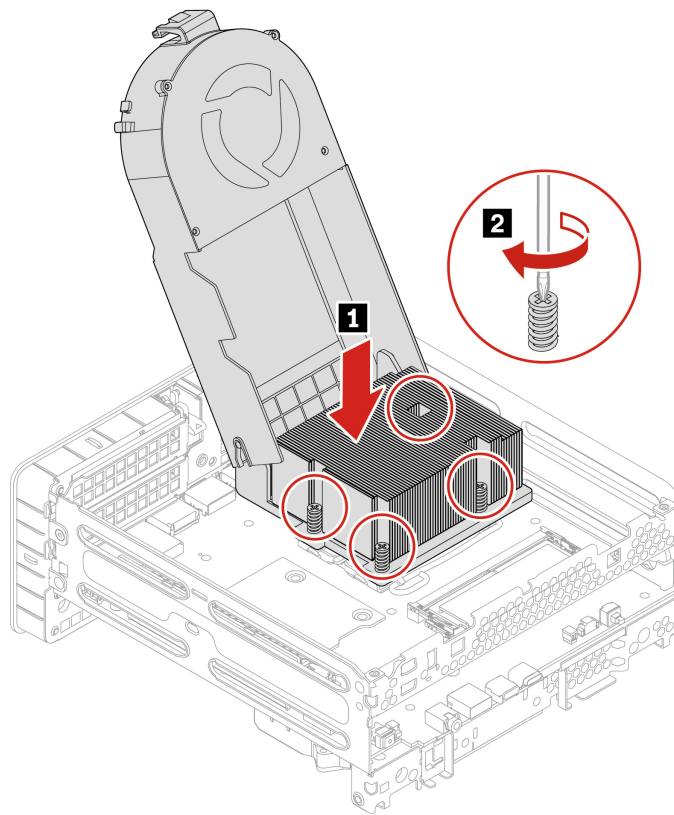

2. Install the system fan.

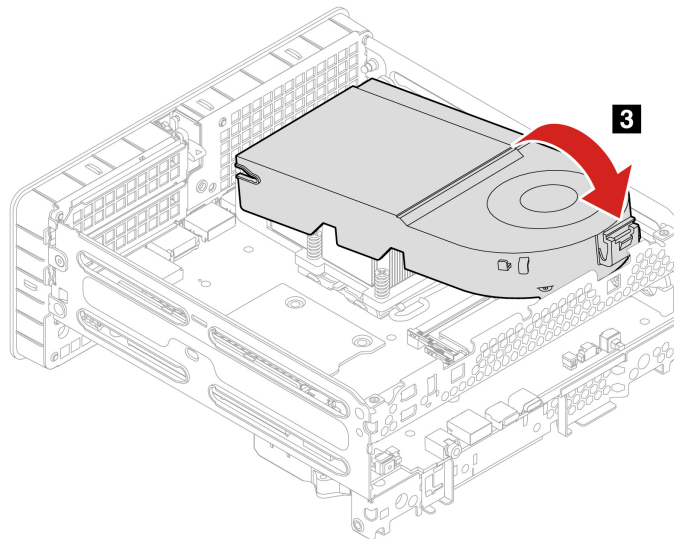

Step	Screw (quality)	Color	Torque
2	M3 x L17.8 mm, flat-head (4)	Bright Ni	3.0±0.1 in-lbs

125-watt system fan

Removal steps:

1. Release the system fan latch and lift the system fan up.

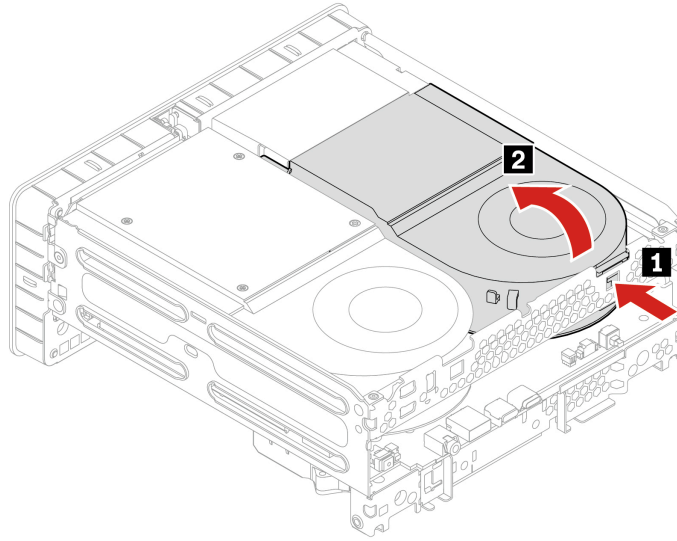

2. Loosen the heat sink screws and remove the heat sink with system fan.

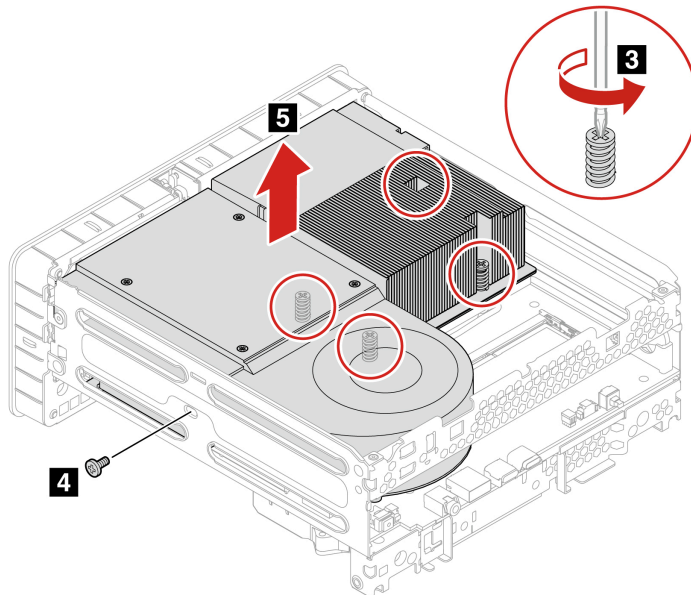

Attention: Use the screws provided by Lenovo to avoid any unpredictable damage to your computer.

Step	Screw (quality)	Color	Torque
3	M3 x L17.4 mm, flat-head (4)	Bright Ni	3.0±0.1 in-lbs
4	M3 x L5 mm, countersunk screw (1)	Blue Zn	5.0±0.1 in-lbs

Installation steps:

1. Secure the heat sink screws.

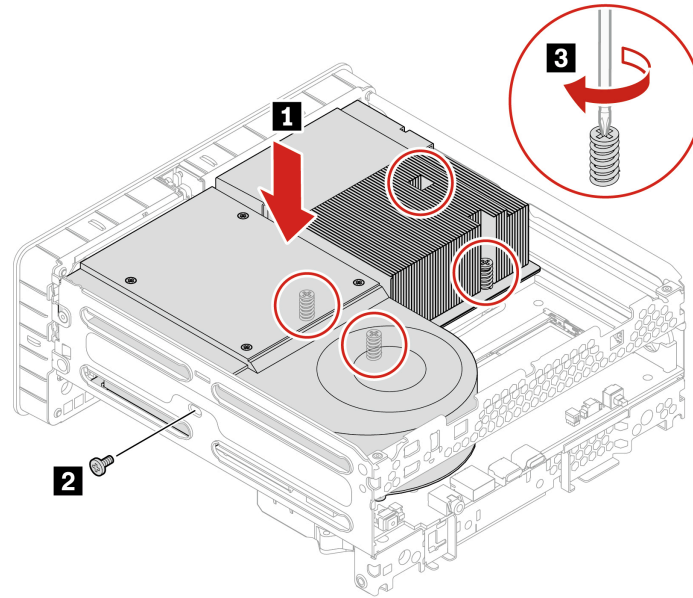

2. Install the system fan.

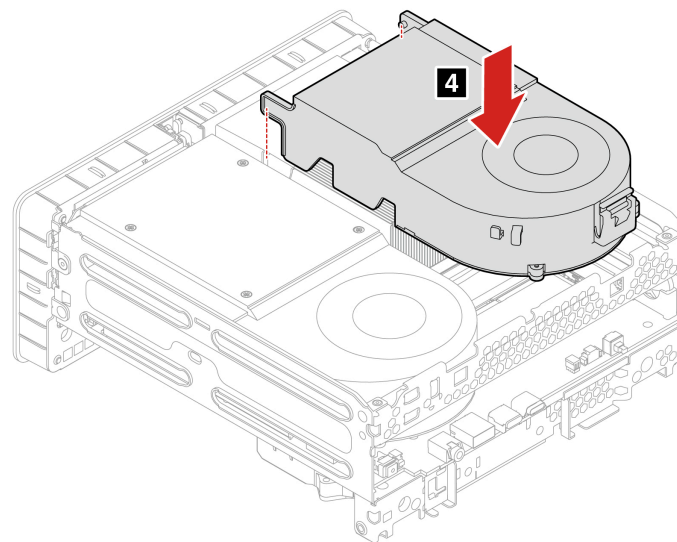

Attention: Use the screws provided by Lenovo to avoid any unpredictable damage to your computer.

Step	Screw (quality)	Color	Torque
2	M3 x L5 mm, countersunk screw (1)	Blue Zn	5.0±0.1 in-lbs
3	M3 x L17.4 mm, flat-head (4)	Bright Ni	3.0±0.1 in-lbs

Memory module

Prerequisite

Before you start, read *Generic Safety and Compliance Notices*, and print the following instructions.

Notes:

- To remove or install the memory module, wait at least 20 seconds after disconnecting power cords from the system. It allows the system to be completely discharged of electricity.
- Ensure that you follow the installation order for memory modules shown in the following illustration.

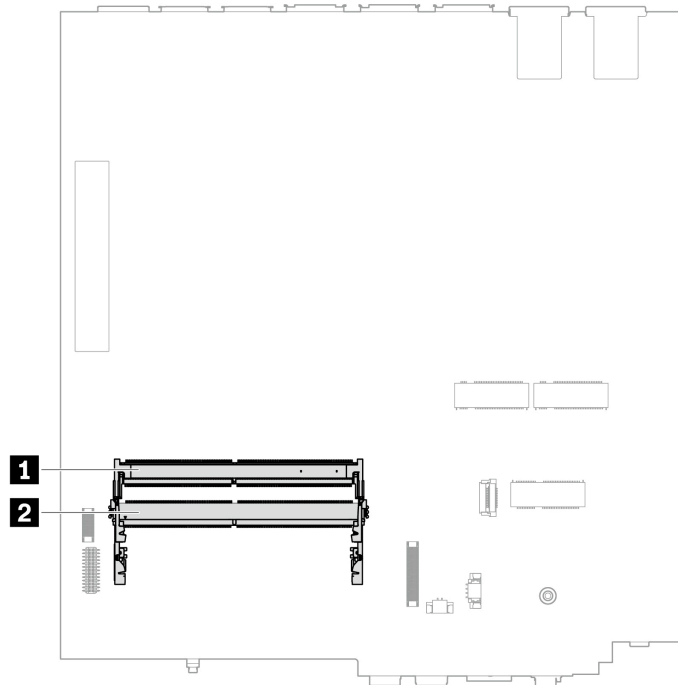

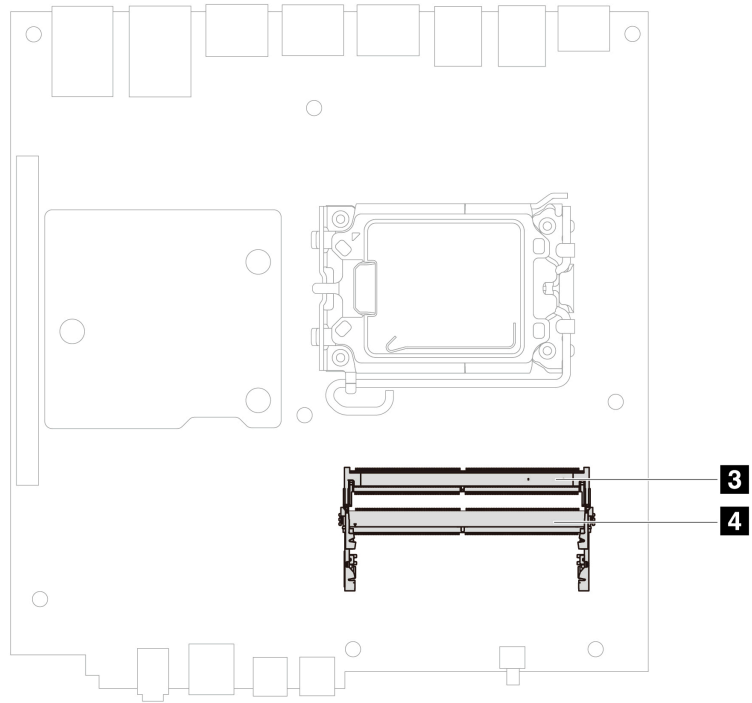

Type-1 memory module

For access, do the following:

1. Remove the power adapter and power cord. See “Power adapter and power cord” on page 23.
2. Remove the chassis. See “Chassis” on page 25.

Removal steps:

Remove the memory module.

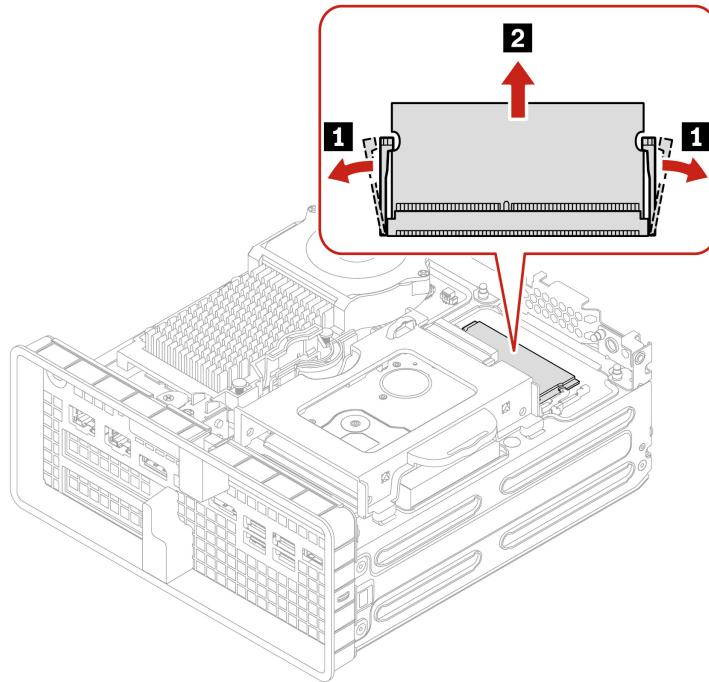

Installation steps:

Install the memory module.

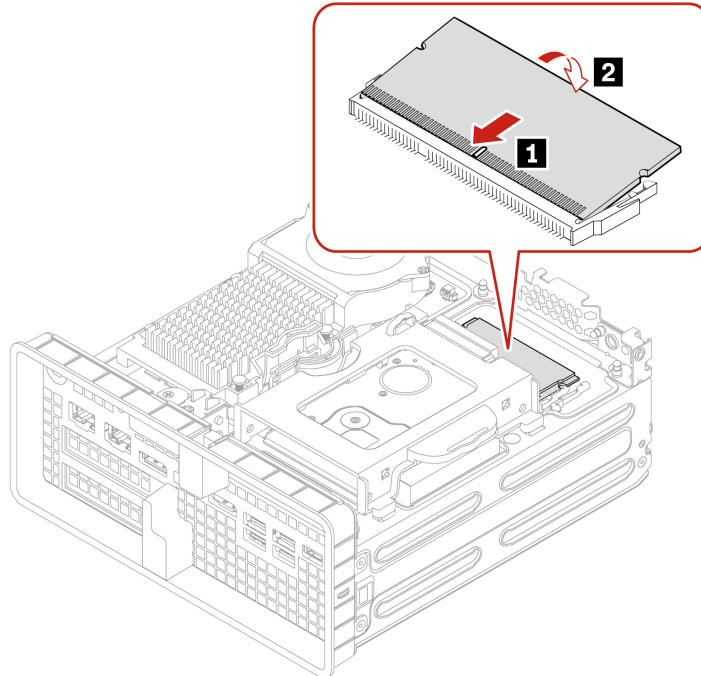

Type-2 memory module

For access, do the following:

1. Remove the power adapter and power cord. See “Power adapter and power cord” on page 23.

2. Remove the chassis. See “Chassis” on page 25.
3. Disconnect the system fan cable from the system board, and lift the system fan. See “System fan and its heat sink” on page 33.

Removal steps:

Remove the memory module.

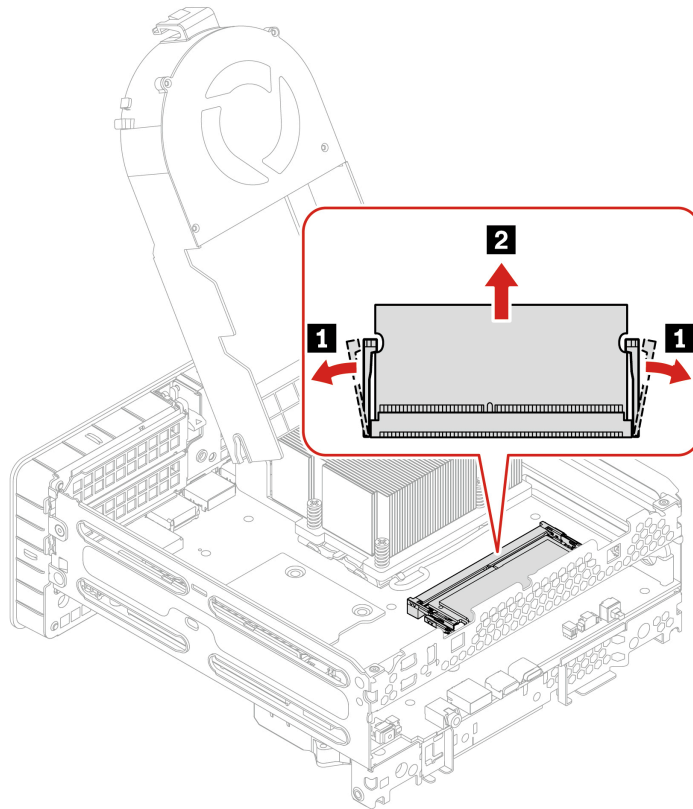

Installation steps:

Install the memory module.

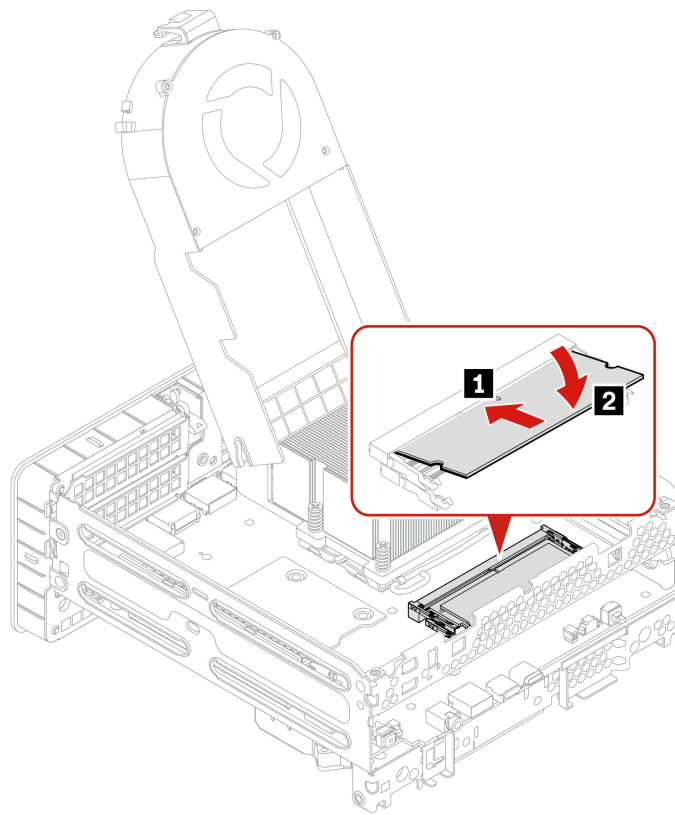

PCI-Express card

Prerequisite

Before you start, read *Generic Safety and Compliance Notices*, and print the following instructions.



The system fan and heat sink be very hot. Before you open the chassis, turn off the computer and wait several minutes until the computer is cool.

For access, do the following:

1. Remove the power adapter and cord. See “Power adapter and power cord” on page 23.
2. Remove the chassis. See “Chassis” on page 25.

Note: Before installing a new PCI-Express card, remove any PCI-Express connector cables that impede the installation.

Type-1 PCI-Express card

Removal steps:

Remove the PCI-Express card.

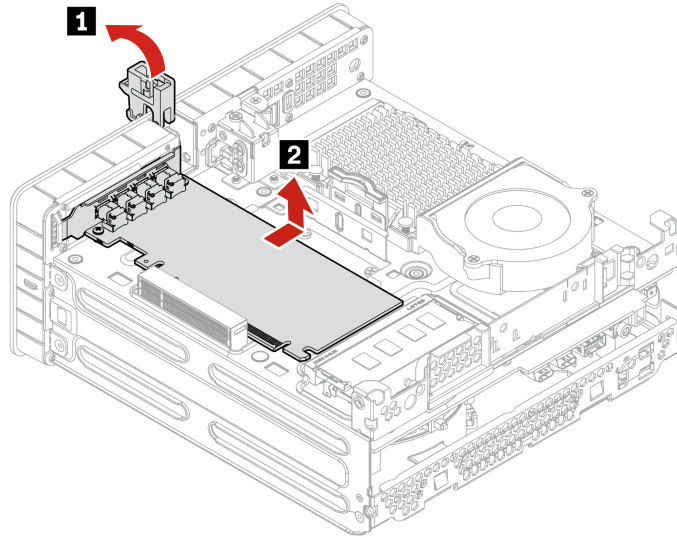

Type-2 PCI-Express card

Removal steps:

1. Remove the PCI-Express bracket.

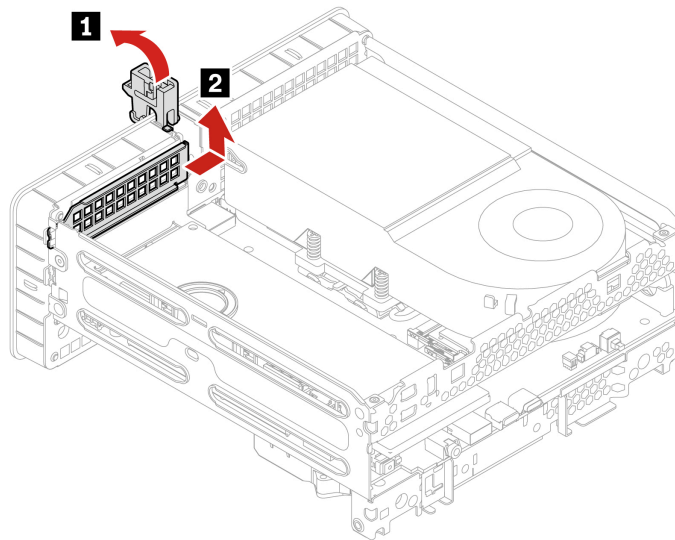

2. Remove the PCI-Express card.

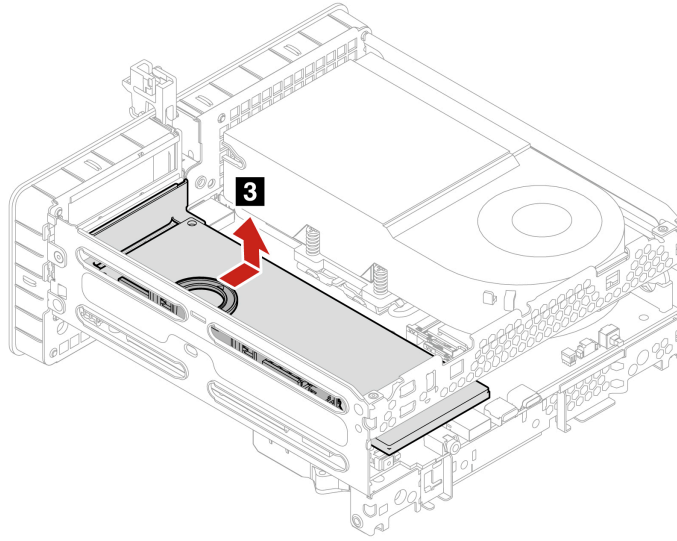

3. Remove the PCI-Express card from the converter.

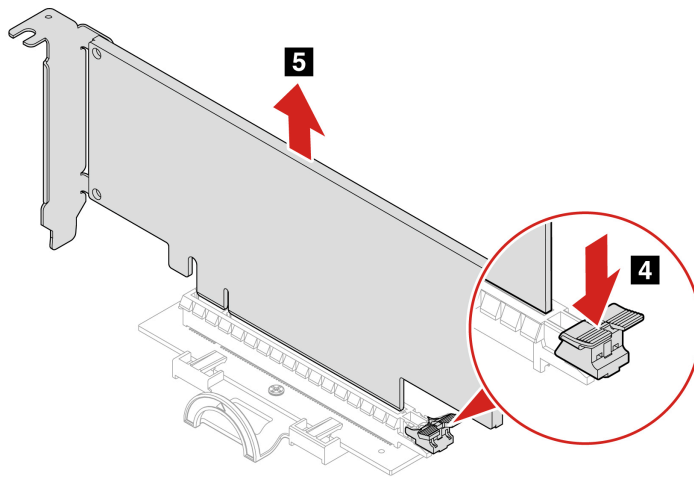

Installation steps:

1. Install the PCI-Express card to the converter.

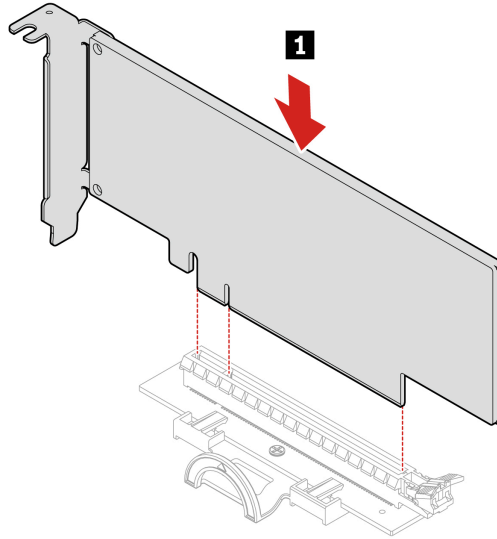

2. Install the PCI-Express card.

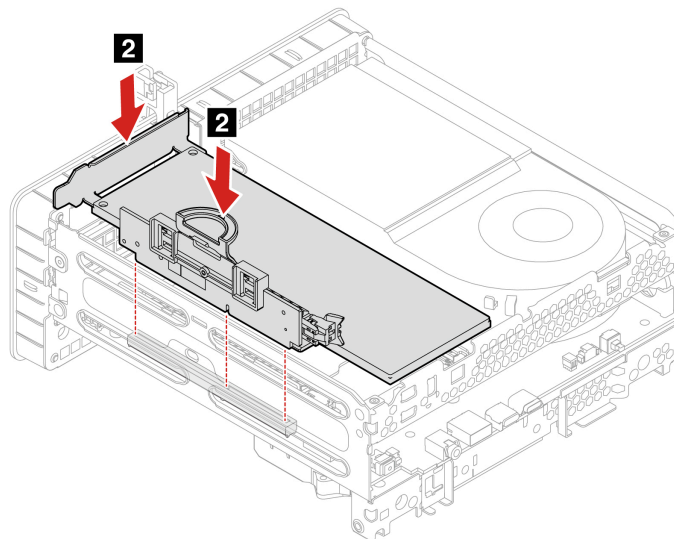

3. Install the PCI-Express bracket.

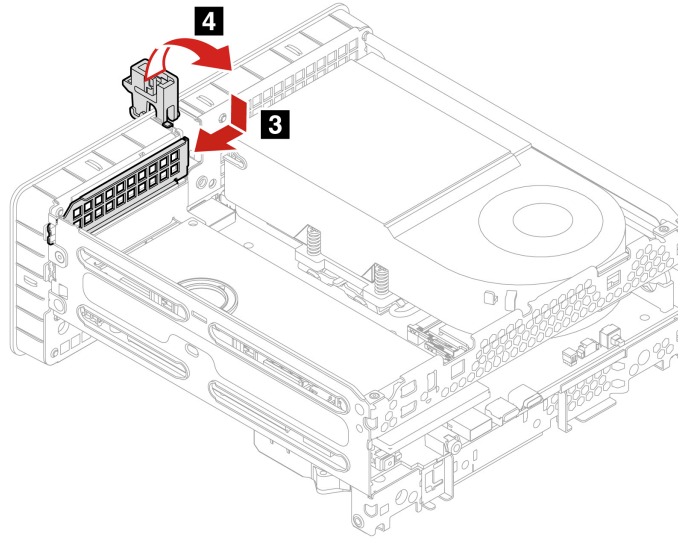

Type-3 PCI-Express card

Removal steps:

1. Remove the PCI-Express bracket.

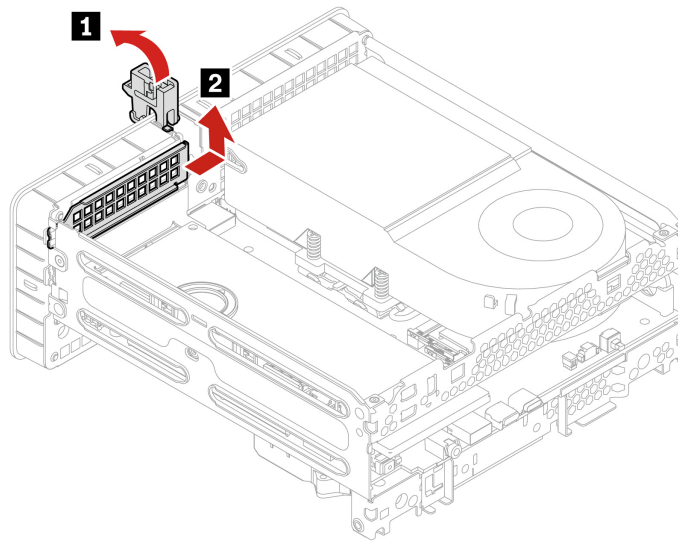

2. Remove one screw and remove the PCI-Express card.

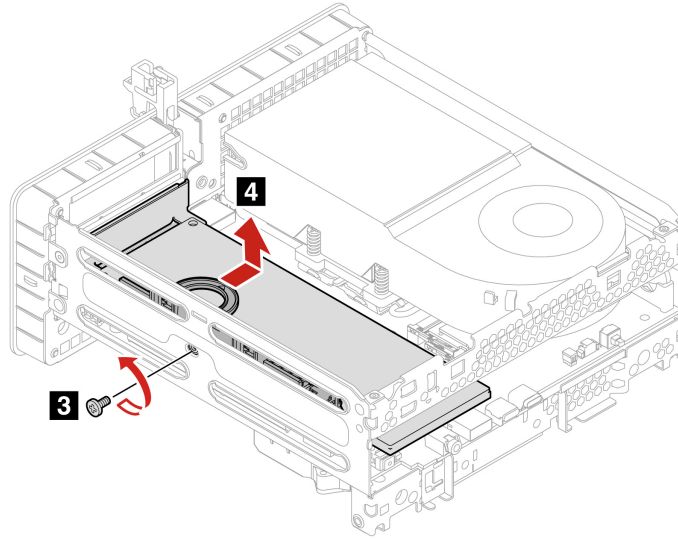

3. Remove the PCI-Express card from the converter.

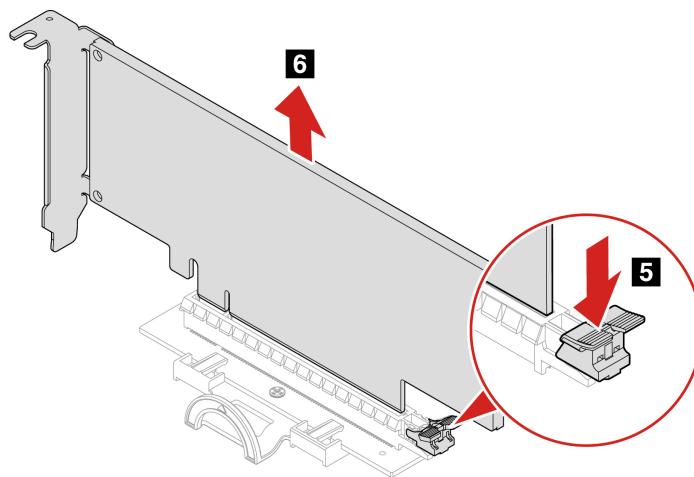

Attention: Use the screws provided by Lenovo to avoid any unpredictable damage to your computer.

Step	Screw (quality)	Color	Torque
3	M3 x L5 mm, countersunk screw (1)	Blue Zn	5.0±0.1 in-lbs

Installation steps:

1. Install the PCI-Express card to the converter.

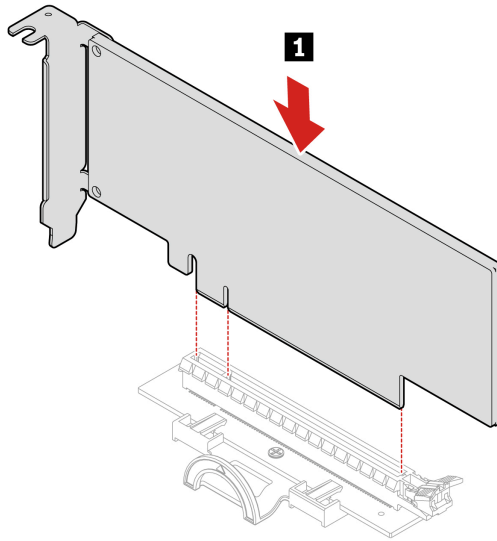

2. Install the PCI-Express card.

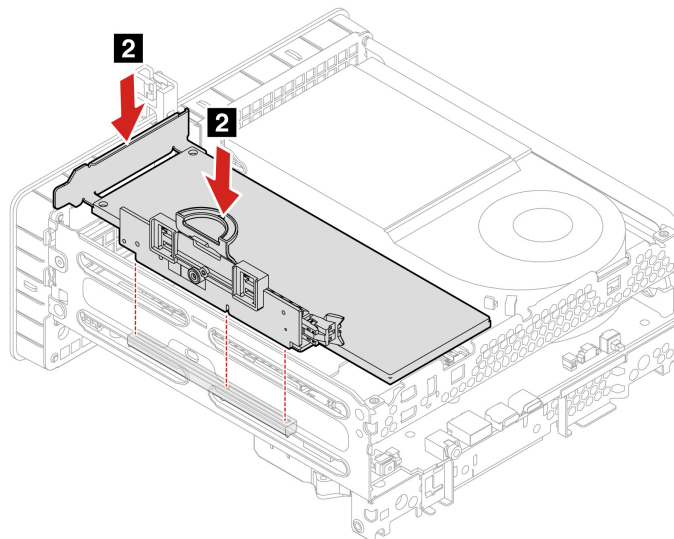

3. Install the screw to secure the PCI-Express card on the computer and install the PCI-Express bracket.

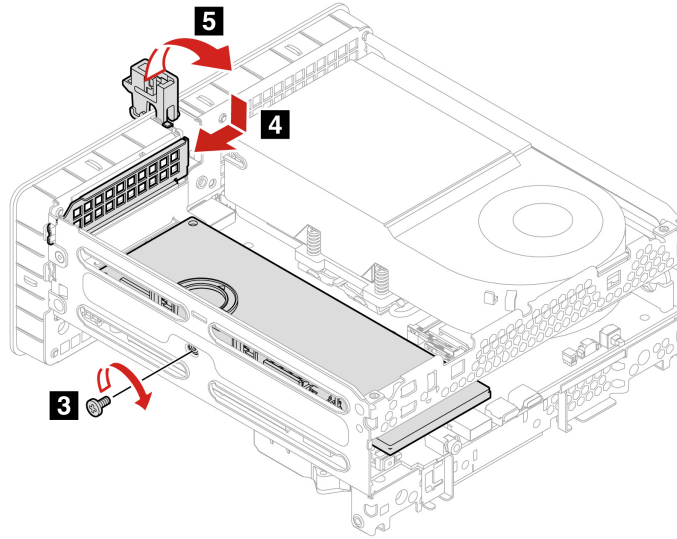

Attention: Use the screws provided by Lenovo to avoid any unpredictable damage to your computer.

Step	Screw (quality)	Color	Torque
3	M3 x L5 mm, countersunk screw (1)	Blue Zn	5.0±0.1 in-lbs

Type-4 PCI-Express card

Removal steps:

1. Remove the PCI-Express card.

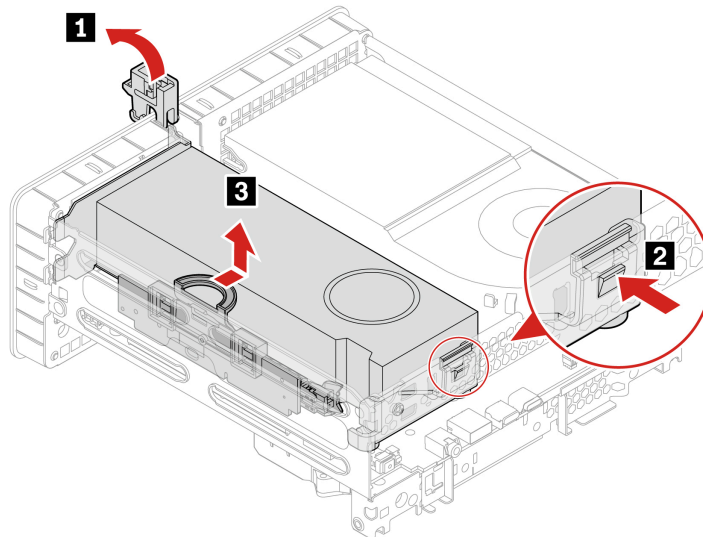

2. Remove the PCI-Express card from the converter.

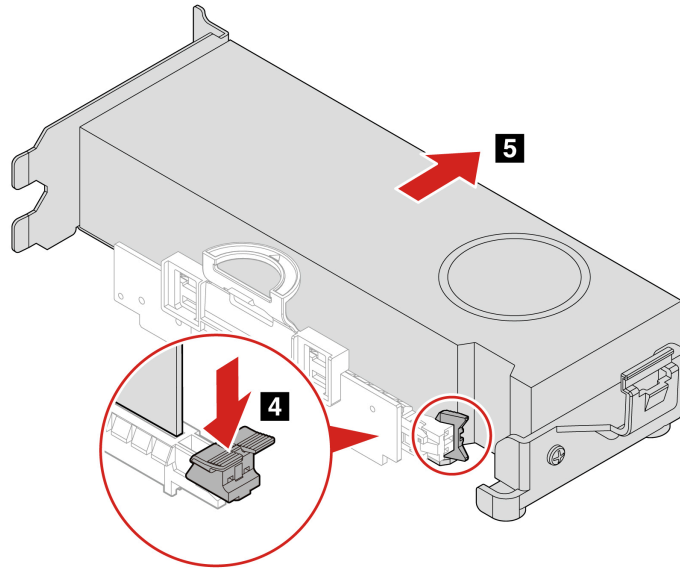

3. Remove the PCI-Express card holder.

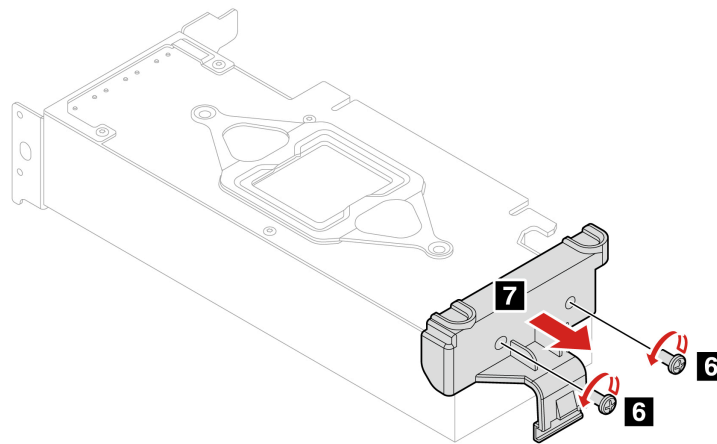

Attention: Use the screws provided by Lenovo to avoid any unpredictable damage to your computer.

Step	Screw (quality)	Color	Torque
6	M3 x L5 mm, hex screw (2)	Black Ni	5.0±0.1 in-lbs

Installation steps:

1. Install the PCI-Express card holder.

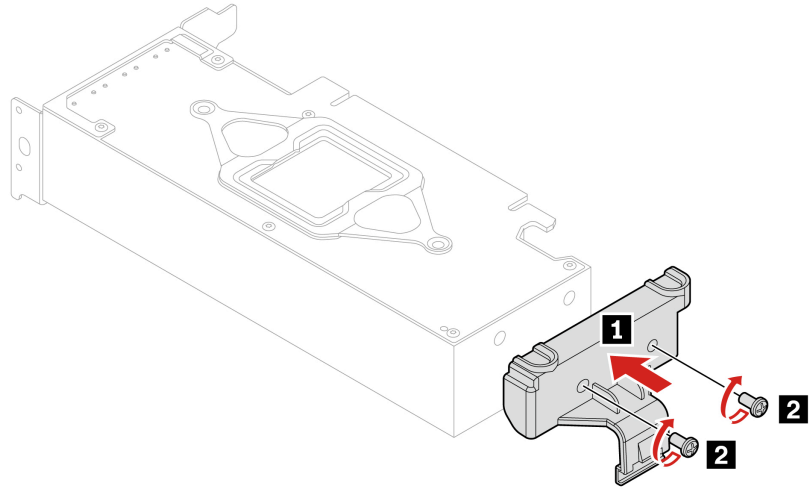

2. Install the PCI-Express card converter.

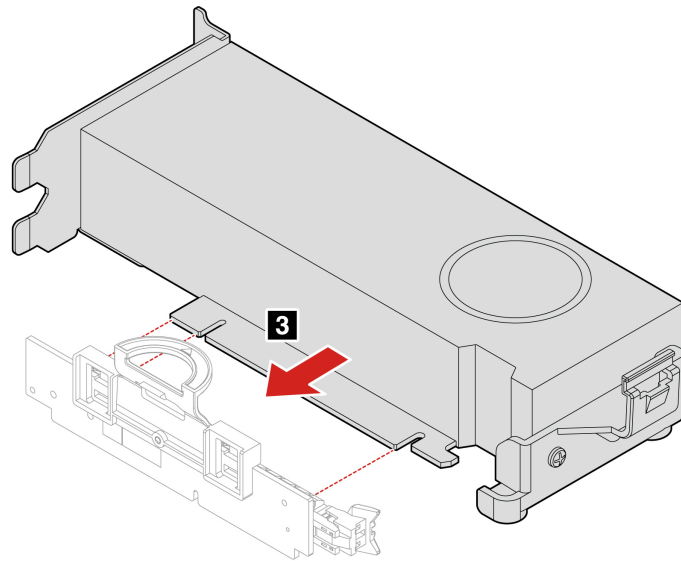

3. Install the PCI-Express card.

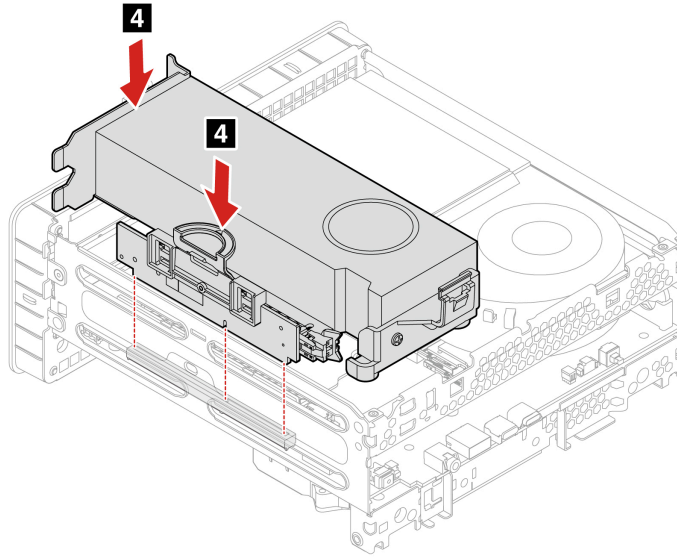

4. Use the screws provided by Lenovo to avoid any unpredictable damage to your computer.

Step	Screw (quality)	Color	Torque
2	M3 x L5 mm, hex screw (2)	Black Ni	5.0±0.1 in-lbs

Type-5 PCI-Express card

Removal steps:

1. Lift up the system fan and disconnect the PCI-Express card fan cable.

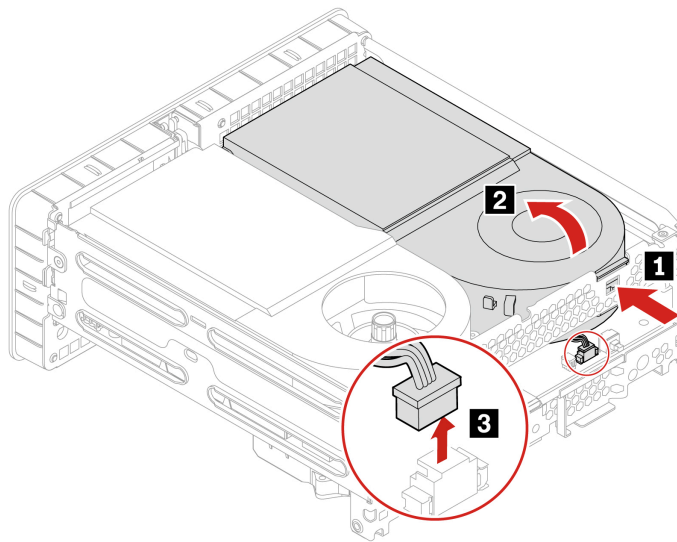

2. Restore the system fan and remove the PCI-Express card fan.

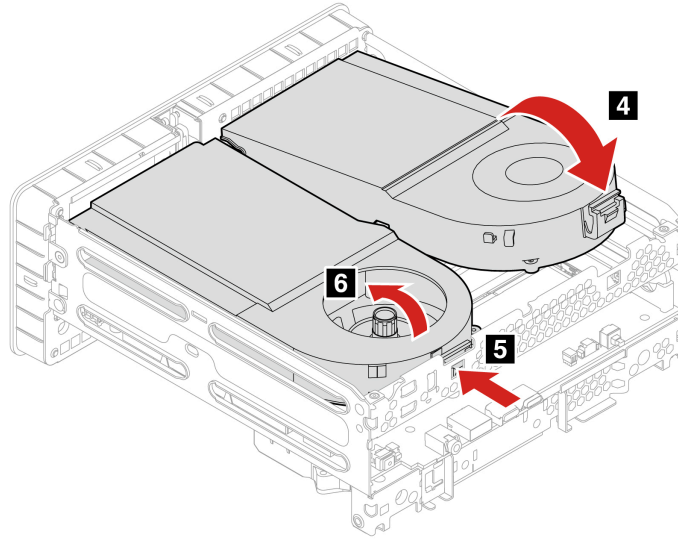

3. Remove the PCI-Express card bracket.

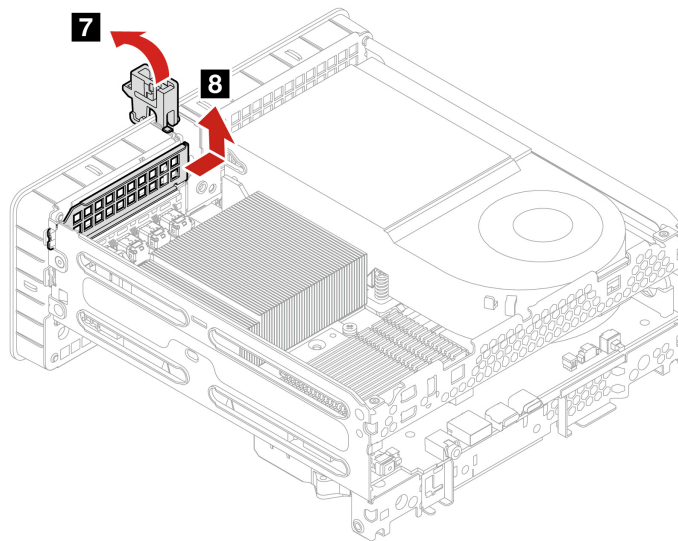

4. Remove the PCI-Express card.

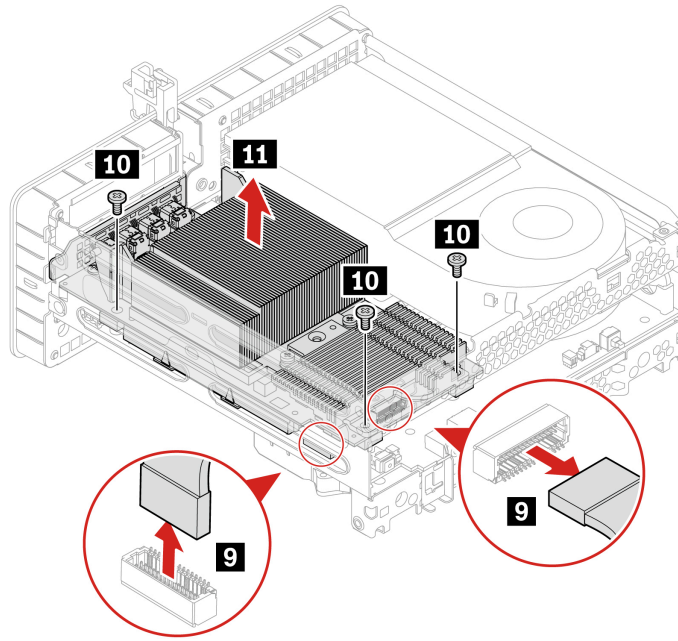

5. Remove the MOS heat sink from the PCI-Express card.

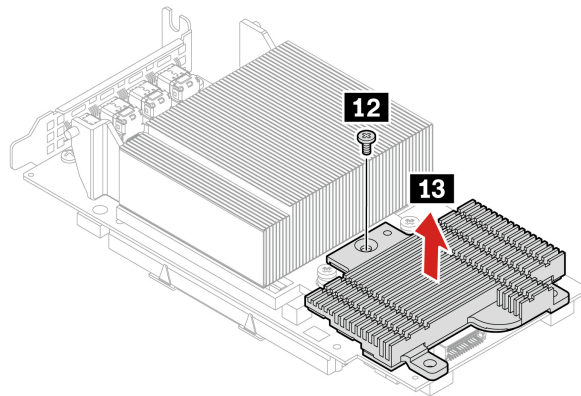

6. Remove the thermal heat sink from the PCI-Express card.

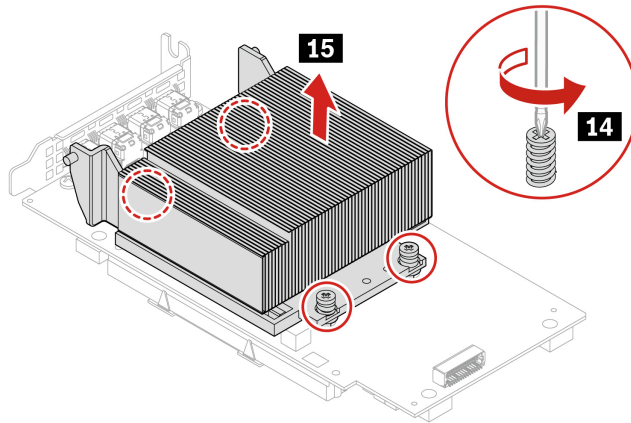

Attention: Use the screws provided by Lenovo to avoid any unpredictable damage to your computer.

Step	Screw (quality)	Color	Torque
10 12	M3 x L12 mm (4)	Black Zn	5.0±0.1 in-lbs
14	M3 x L12 mm, captive screw (4)	Bright Ni	3.0±0.5 in-lbs

Installation steps:

1. Install the thermal heat sink to the PCI-Express card.

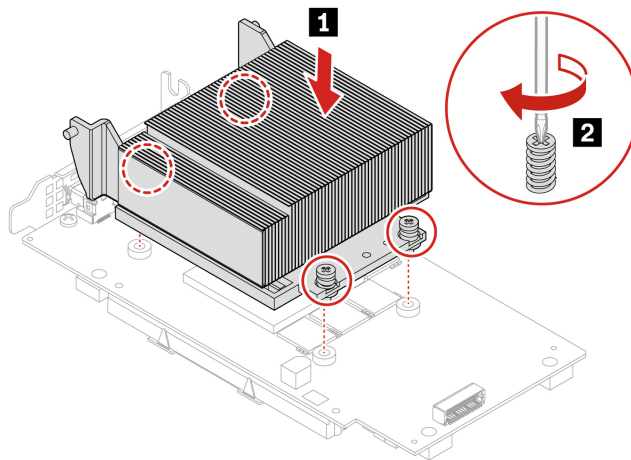

2. Remove the PCI-Express card bracket.

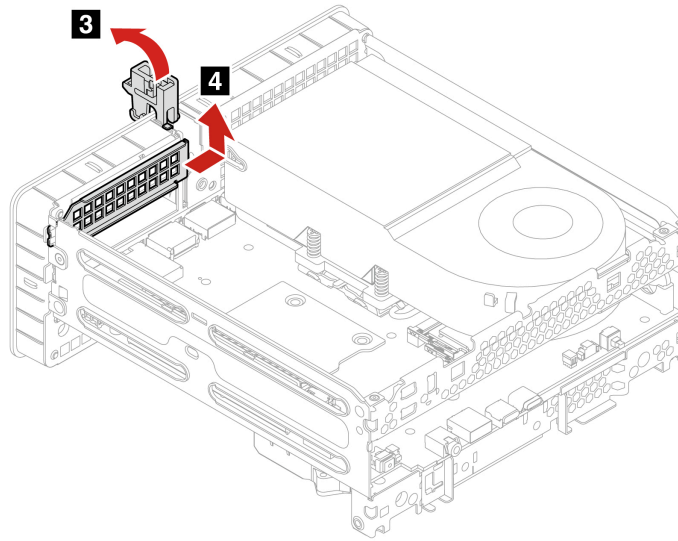

3. Install the PCI-Express card.

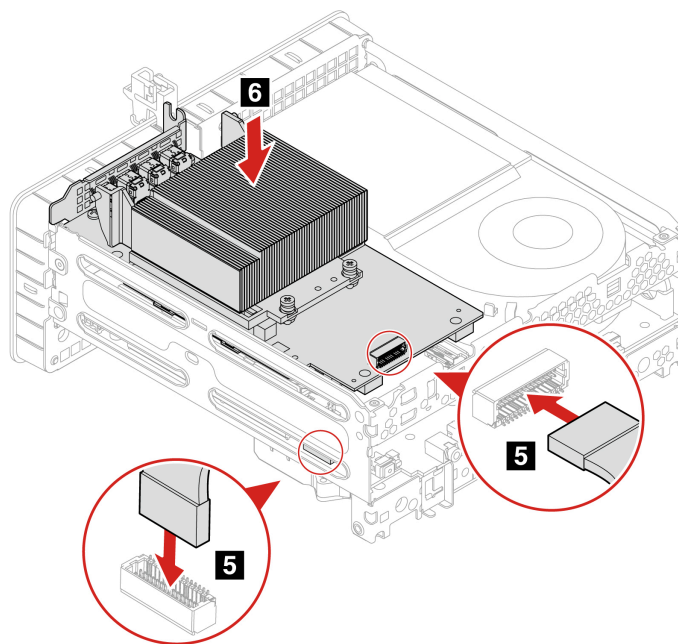

4. Install the MOS heat sink to the PCI-Express card, and secure the PCI-Express card with screws.

Note: Ensure that the holes on both heat sinks are aligned before installing.

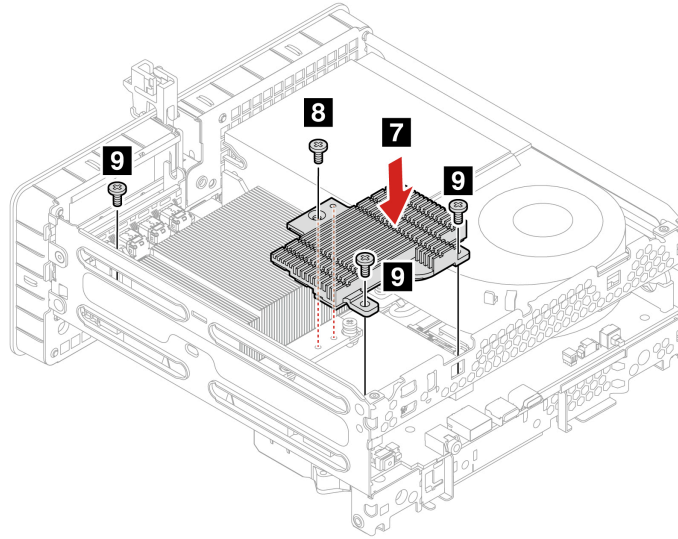

5. Install the PCI-Express card bracket and restore the PCI-Express card latch.

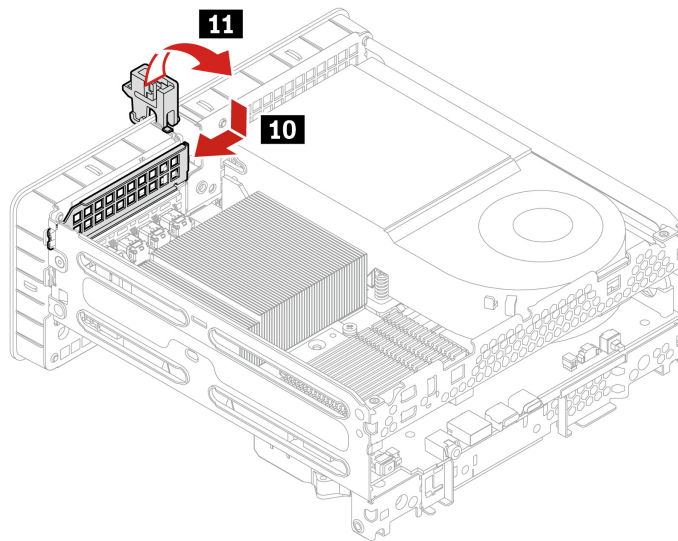

6. Connect the PCI-Express card fan cable and install the fan.

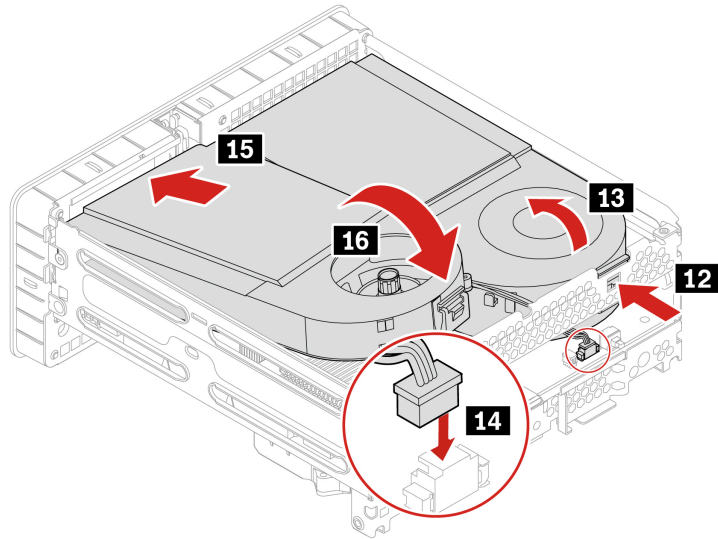

7. Install the system fan.

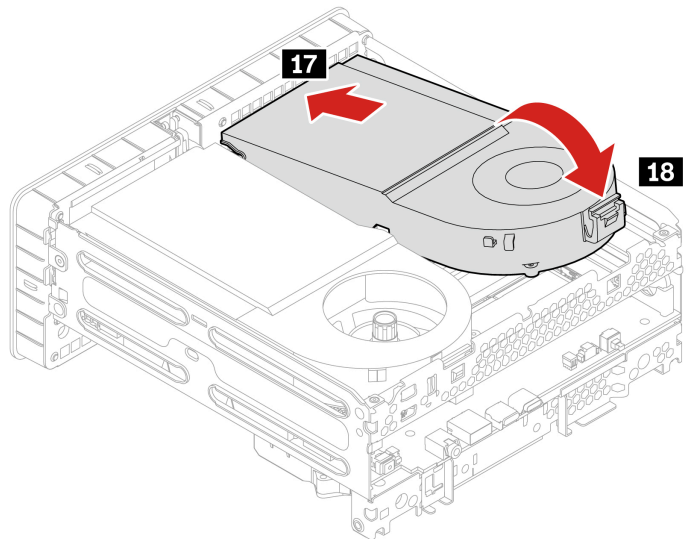

Attention: Use the screws provided by Lenovo to avoid any unpredictable damage to your computer.

Step	Screw (quality)	Color	Torque
2	M3 x L12 mm, captive screw (4)	Bright Ni	3.0±0.5 in-lbs
8 9	M3 x L12 mm (4)	Black Zn	5.0±0.1 in-lbs

Chapter 5. Help and support

Self-help resources

Use the following self-help resources to learn more about the computer and troubleshoot problems.

Resources	How to access?
Product documentation: <ul style="list-style-type: none">• <i>Safety and Warranty Guide</i>• <i>Generic Safety and Compliance Notices</i>• <i>Setup Guide</i>• <i>This User Guide</i>• <i>Regulatory Notice</i>	Go to https://support.lenovo.com/documentation and search by product.
Lenovo Support Web site with the latest support information of the following: <ul style="list-style-type: none">• Drivers and software• Diagnostic solutions• Product and service warranty• Product and parts details• Knowledge base and frequently asked questions	https://pcsupport.lenovo.com
Ubuntu help information	https://help.ubuntu.com/lts/ubuntu-help/index.html
IGEL support information	https://support.igel.com/

Lenovo diagnostic tools

For information about Lenovo diagnostic tools, go to:
<https://pcsupport.lenovo.com/lenovodiagnosicsolutions>

Call Lenovo

If you have tried to correct the problem yourself and still need help, you can call Lenovo Customer Support Center.

Before you contact Lenovo

Prepare the following before you contact Lenovo:

1. Record the problem symptoms and details:
 - What is the problem? Is it continuous or intermittent?
 - Any error message or error code?
 - What operating system are you using? Which version?
 - Which software applications were running at the time of the problem?
 - Can the problem be reproduced? If so, how?
2. Record the system information:
 - Product name
 - Machine type and serial number

The following illustration shows where to find the machine type and serial number of your computer.

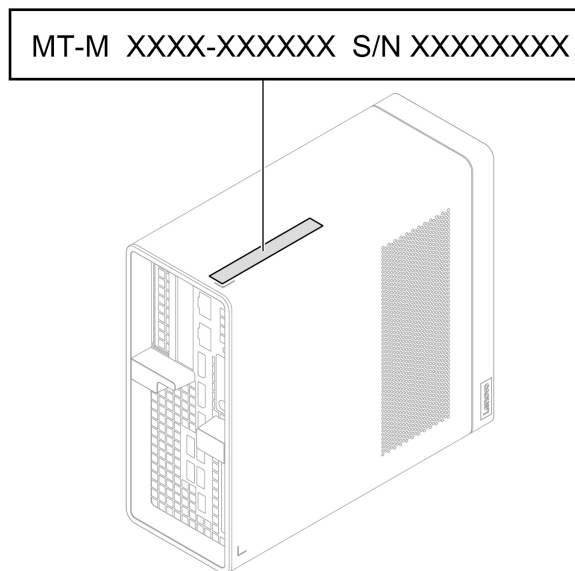

Lenovo Customer Support Center

During the warranty period, you can call Lenovo Customer Support Center for help.

Telephone numbers

For a list of the Lenovo Support phone numbers for your country or region, go to:

<https://pcsupport.lenovo.com/supportphonenumberlist>

Note: Phone numbers are subject to change without notice. If the number for your country or region is not provided, contact your Lenovo reseller or Lenovo marketing representative.

Services available during the warranty period

- Problem determination - Trained personnel are available to assist you with determining if you have a hardware problem and deciding what action is necessary to fix the problem.
- Lenovo hardware repair - If the problem is determined to be caused by Lenovo hardware under warranty, trained service personnel are available to provide the applicable level of service.
- Engineering change management - Occasionally, there might be changes that are required after a product has been sold. Lenovo or your reseller, if authorized by Lenovo, will make selected Engineering Changes (ECs) that apply to your hardware available.

Services not covered

- Replacement or use of parts not manufactured for or by Lenovo or nonwarranted parts
- Identification of software problem sources
- Configuration of UEFI BIOS as part of an installation or upgrade
- Changes, modifications, or upgrades to device drivers
- Installation and maintenance of network operating systems (NOS)
- Installation and maintenance of programs

For the terms and conditions of the Lenovo Limited Warranty that apply to your Lenovo hardware product, see *Safety and Warranty Guide* that comes with your computer.

Certification-related information

Product name: ThinkStation P3 Ultra

Machine types: 30HB and 30HA

Further compliance information related to your product is available at <https://www.lenovo.com/compliance>.

Purchase accessories

Lenovo has a number of hardware accessories and upgrades to help expand the capabilities of your computer. Options include memory modules, storage devices, network cards, power adapters, keyboards, mice, and more.

To shop at Lenovo, go to <https://www.lenovo.com/accessories>.

Purchase additional services

During and after the warranty period, you can purchase additional services from Lenovo at: <https://pcsupport.lenovo.com/warrantyupgrade>

Service availability and service name might vary by country or region.

Accessibility features

Lenovo is committed to making information technology accessible to everyone, including individuals with hearing, vision, mobility, cognitive, or speech disabilities. To get the most up-to-date and detailed accessibility features information for the product, go to https://support.lenovo.com/docs/product_accessibility_features.

Appendix A. Supplemental information about the Ubuntu operating system

In limited countries or regions, Lenovo offers customers an option to order computers with the preinstalled Ubuntu® operating system.

If the Ubuntu operating system is available on your computer, read the following information before you use the computer. Ignore any information related to Windows-based programs, utilities, and Lenovo preinstalled applications in this documentation.

Access the Lenovo Limited Warranty

This product is covered by the terms of the Lenovo Limited Warranty (LLW), version L505-0010-02 08/2011. You can view the LLW in a number of languages from the following Web site. Read the Lenovo Limited Warranty at:

https://www.lenovo.com/warranty/llw_02

The LLW also is preinstalled on the computer. To access the LLW, go to the following directory:

```
/opt/Lenovo
```

If you cannot view the LLW either from the Web site or from your computer, contact your local Lenovo office or reseller to obtain a printed version of the LLW.

Access the Ubuntu help system

The Ubuntu help system provides information about how to use the Ubuntu operating system. To access the help system from Home Screen, move your pointer to the Launch bar, and then click the **Help** icon. If you cannot find the **Help** icon from the Launch bar, click the **Search** icon on the bottom left, and type Help to search it.

To learn more about the Ubuntu operating system, go to:

<https://www.ubuntu.com>

Access Linux distributions

To learn more about the IGEL operating system, go to <https://www.igel.com/support>.

Get support information

If you need help, service, technical assistance, or more information about the Ubuntu operating system or other applications, contact the provider of the Ubuntu operating system or the provider of the application. If you need the service and support for hardware components shipped with your computer, contact Lenovo. For more information about how to contact Lenovo, refer to the *User Guide* and *Safety and Warranty Guide*.

To access the latest *User Guide* and *Safety and Warranty Guide*, go to:

<https://pcsupport.lenovo.com>

Access open-source information

This device includes software made publicly available by Lenovo, including software licensed under the General Public License and/or the Lesser General Public License (the open source software).

You may obtain a copy of the corresponding source code for any such open source software licensed under the General Public License and/or the Lesser General Public License (or any other license requiring us to

make a written offer to provide corresponding source code to you) from Lenovo for a period of three years without charge except for the cost of media, shipping, and handling, upon written request to Lenovo. This offer is valid to anyone in receipt of this device.

You may send your request in writing to the address below accompanied by a check or money order for \$15 to:

Lenovo Legal Department
Attn: Open Source Team / Source Code Requests
8001 Development Dr.
Morrisville, NC 27560

Please include the version of the OS and the version of the Linux Kernel pre-shipped on this Device as part of your request. Be sure to provide a return address.

The open source software is distributed in hope it will be useful, but WITHOUT ANY WARRANTY; without even the implied warranty of MERCHANTABILITY or FITNESS FOR A PARTICULAR PURPOSE. See for example the GNU General Public License and/or the Lesser General Public License for more information.

To view additional information regarding licenses, acknowledgments and required copyright notices for the open source software shipped on your Device, go to `/usr/share/doc/*/copyright`.

Appendix B. Notices and trademarks

Notices

Lenovo may not offer the products, services, or features discussed in this document in all countries. Consult your local Lenovo representative for information on the products and services currently available in your area. Any reference to a Lenovo product, program, or service is not intended to state or imply that only that Lenovo product, program, or service may be used. Any functionally equivalent product, program, or service that does not infringe any Lenovo intellectual property right may be used instead. However, it is the user's responsibility to evaluate and verify the operation of any other product, program, or service.

Lenovo may have patents or pending patent programs covering subject matter described in this document. The furnishing of this document does not give you any license to these patents. You can send license inquiries, in writing, to:

*Lenovo (United States), Inc.
8001 Development Drive
Morrisville, NC 27560
U.S.A.
Attention: Lenovo Director of Licensing*

LENOVO PROVIDES THIS PUBLICATION "AS IS" WITHOUT WARRANTY OF ANY KIND, EITHER EXPRESS OR IMPLIED, INCLUDING, BUT NOT LIMITED TO, THE IMPLIED WARRANTIES OF NON-INFRINGEMENT, MERCHANTABILITY OR FITNESS FOR A PARTICULAR PURPOSE. Some jurisdictions do not allow disclaimer of express or implied warranties in certain transactions, therefore, this statement may not apply to you.

Changes are made periodically to the information herein; these changes will be incorporated in new editions of the publication. To provide better service, Lenovo reserves the right to improve and/or modify the products and software programs described in the manuals included with your computer, and the content of the manual, at any time without additional notice.

The software interface and function and hardware configuration described in the manuals included with your computer might not match exactly the actual configuration of the computer that you purchase. For the configuration of the product, refer to the related contract (if any) or product packing list, or consult the distributor for the product sales. Lenovo may use or distribute any of the information you supply in any way it believes appropriate without incurring any obligation to you.

The products described in this document are not intended for use in implantation or other life support applications where malfunction may result in injury or death to persons. The information contained in this document does not affect or change Lenovo product specifications or warranties. Nothing in this document shall operate as an express or implied license or indemnity under the intellectual property rights of Lenovo or third parties. All information contained in this document was obtained in specific environments and is presented as an illustration. The result obtained in other operating environments may vary.

Lenovo may use or distribute any of the information you supply in any way it believes appropriate without incurring any obligation to you.

Any references in this publication to non-Lenovo Web sites are provided for convenience only and do not in any manner serve as an endorsement of those Web sites. The materials at those Web sites are not part of the materials for this Lenovo product, and use of those Web sites is at your own risk.

Any performance data contained herein was determined in a controlled environment. Therefore, the result obtained in other operating environments may vary significantly. Some measurements may have been made on development-level systems and there is no guarantee that these measurements will be the same on generally available systems. Furthermore, some measurements may have been estimated through extrapolation. Actual results may vary. Users of this document should verify the applicable data for their specific environment.

This document is copyrighted by Lenovo and is not covered by any open source license, including any Linux agreement(s) which may accompany software included with this product. Lenovo may update this document at any time without notice.

For the latest information or any questions or comments, contact or visit the Lenovo Web site:
<https://pcsupport.lenovo.com>

Trademarks

LENOVO, LENOVO logo, THINKSTATION, and THINKSTATION logo are trademarks of Lenovo. Intel, Optane, Core, and Thunderbolt are trademarks of Intel Corporation or its subsidiaries in the U.S. and/or other countries. Microsoft, Windows, and Cortana are trademarks of the Microsoft group of companies. DisplayPort is a trademark of the Video Electronics Standards Association. The terms HDMI and HDMI High-Definition Multimedia Interface are trademarks or registered trademarks of HDMI Licensing LLC in the United States and other countries. Kensington and MicroSaver are registered trademarks of ACCO Brands. Wi-Fi, Wi-Fi Alliance, and Miracast are registered trademarks of Wi-Fi Alliance. USB-C is a registered trademark of USB Implementers Forum. All other trademarks are the property of their respective owners.

Lenovo