

# Hardware Maintenance Manual

Lenovo  
**ThinkStation**



ThinkStation P5

**Eleventh Edition (February 2026)**

**© Copyright Lenovo 2023, 2026.**

LIMITED AND RESTRICTED RIGHTS NOTICE: If data or software is delivered pursuant to a General Services Administration "GSA" contract, use, reproduction, or disclosure is subject to restrictions set forth in Contract No. GS-35F-05925.

---

# Contents

## Chapter 1. Important safety information . . . . . 1

General safety . . . . .	1
Electrical safety . . . . .	2
Safety inspection guide . . . . .	3
Handling electrostatic discharge-sensitive devices . . . . .	4
Grounding requirements . . . . .	4
Safety notices (multi-lingual translations) . . . . .	4

## Chapter 2. Important service information . . . . . 27

Strategy for replacing FRUs . . . . .	27
Strategy for replacing a hard disk drive or a solid-state drive . . . . .	27
Important notice for replacing a system board . . . . .	27
How to use error codes . . . . .	28
Strategy for replacing FRUs for CTO, special-bid, and standard models. . . . .	28
Product definition . . . . .	28
FRU identification . . . . .	28

## Chapter 3. Product overview . . . . . 29

Front . . . . .	29
Rear . . . . .	30

## Chapter 4. Service checkout and symptom-to-FRU index . . . . . 32

Service checkout . . . . .	32
Problem determination tips . . . . .	32
Symptom-to-FRU index . . . . .	33
Hard disk drive boot error . . . . .	33
Power supply problems . . . . .	34
Beep symptoms . . . . .	34
POST error codes . . . . .	35
Miscellaneous error conditions . . . . .	36
Undetermined problems . . . . .	38
Recover from a BIOS update failure . . . . .	38
Clear CMOS . . . . .	39

## Chapter 5. RAID . . . . . 40

What is RAID . . . . .	40
Configure RAID with Intel RSTe. . . . .	40
Configure RAID with AVAGO MegaRAID Configuration Utility . . . . .	41
Configure RAID with Intel Virtual RAID on CPU. . . . .	43

## Chapter 6. Diagnostics . . . . . 46

Basic procedure for resolving computer problems . . . . .	46
UEFI diagnostic program . . . . .	46
Lenovo diagnostic tools . . . . .	47
Use the Vantage app. . . . .	48
Self-help resources . . . . .	48

## Chapter 7. Hardware replacement . . . 50

Handling static-sensitive devices . . . . .	50
Service tool kit . . . . .	50
Expand your computer . . . . .	52
System board illustration . . . . .	54
Major FRUs and CRUs . . . . .	55
External options. . . . .	58
ID badge . . . . .	58
ThinkStation logo badge . . . . .	59
Side cover . . . . .	59
Top cover . . . . .	61
Front panel I/O assembly . . . . .	62
Internal speaker. . . . .	63
Think LED cable. . . . .	64
Power supply assembly. . . . .	65
Power supply unit cover . . . . .	67
Power distribution board and bracket . . . . .	68
Memory module . . . . .	69
Fans . . . . .	71
Front fan. . . . .	71
Rear fan . . . . .	72
Memory fan duct . . . . .	72
Memory fan . . . . .	73
HDD fan . . . . .	74
Flex bay fan . . . . .	74
Storage drives . . . . .	75
HDD and its bracket . . . . .	75
Optional HDD and its cage. . . . .	77
Flex bay cage . . . . .	78
15-in-1 media card reader . . . . .	78
Flex module . . . . .	79
M.2 SSD in flex module . . . . .	80
Onboard M.2 SSD and its heatsink kit . . . . .	82
M.2 SSD holder . . . . .	84
M.2 SSD on an M.2 SSD PCIe adapter . . . . .	85
PCIe cards. . . . .	93
NVLINK retainer . . . . .	93
NVLINK bridge . . . . .	94
Super capacitor module. . . . .	95
PCIe bracket . . . . .	96
PCIe card and extender . . . . .	97
PCIe card installation rule . . . . .	101

Cable connection . . . . .	102
BMC card . . . . .	106
Wi-Fi card . . . . .	107
Wi-Fi antenna . . . . .	108
Ambient temp sensor . . . . .	109
CPU heat sink . . . . .	110
CPU . . . . .	111
Cover presence switch . . . . .	113

Coin-cell battery . . . . .	113
System board . . . . .	115

**Appendix A. Important notice for Quebec consumers . . . . .117**

**Appendix B. Notices and trademarks. . . . .118**

## About this manual

This manual provides service and reference information for ThinkStation® computers listed on the front cover.

Illustrations in this manual might look different from your product.

Use this manual along with the advanced diagnostic tests to troubleshoot problems.

**Important:** It is recommended that these products be repaired by trained service technicians. For customers electing to repair their own ThinkStation products, please follow all instructions carefully. Use this manual along with the advanced diagnostic tests to troubleshoot problems effectively. Before servicing a ThinkStation computer, be sure to read and understand Chapter 1 “Important safety information” on page 1.

---

# Chapter 1. Important safety information

---

## General safety

Follow these rules to ensure general safety:

- Observe good housekeeping in the area of the machines during and after maintenance.
- When lifting any heavy object:
  1. Ensure you can stand safely without slipping.
  2. Distribute the weight of the object equally between your feet.
  3. Use a slow lifting force. Never move suddenly or twist when you attempt to lift.
  4. Lift by standing or by pushing up with your leg muscles; this action removes the strain from the muscles in your back.

**Attention:** Do not attempt to lift any objects that weigh more than 16 kg (35 lb) or objects that you think are too heavy for you.

- Do not perform any action that causes hazards to the customer, or that makes the equipment unsafe.
- Before you start the machine, ensure that other people are not in a hazardous position.
- Place removed covers and other parts in a safe place, away from all personnel, while you are servicing the machine.
- Keep your tool case away from walk areas so that other people will not trip over it.
- Do not wear loose clothing that can be trapped in the moving parts of a machine. Ensure that your sleeves are fastened or rolled up above your elbows. If your hair is long, fasten it.
- Insert the ends of your necktie or scarf inside clothing or fasten it with a nonconductive clip, approximately 8 centimeters (3 inches) from the end.
- Do not wear jewelry, chains, metal-frame eyeglasses, or metal fasteners for your clothing.

**Remember:** Metal objects are good electrical conductors.

- Wear safety glasses when you are: hammering, drilling, soldering, cutting wire, attaching springs, using solvents, or working in any other conditions that might be hazardous to your eyes.
- After service, reinstall all safety shields, guards, labels, and ground wires. Replace any safety device that is worn or defective.
- Reinstall all covers correctly before returning the machine to the customer.

### CAUTION:



**Keep fingers and other parts of your body away from hazardous, moving parts. If you suffer an injury, seek medical care immediately.**

### CAUTION:



**Avoid contact with hot components inside the computer. During operation, some components become hot enough to burn the skin. Before you open the computer cover, turn off the computer, disconnect power, and wait approximately 10 minutes for the components to cool.**

---

## Electrical safety



### CAUTION:

**Electrical current from power, telephone, and communication cables can be hazardous. To avoid personal injury or equipment damage, disconnect the attached power cords, telecommunication systems, networks, and modems before you open the computer covers, unless instructed otherwise in the installation and configuration procedures.**

Observe the following rules when working on electrical equipment.

**Important:** Use only approved tools and test equipment. Some hand tools have handles covered with a soft material that does not insulate you when working with live electrical currents. Many customers have, near their equipment, rubber floor mats that contain small conductive fibers to decrease electrostatic discharges. Do not use this type of mat to protect yourself from electrical shock.

- Find the room emergency power-off (EPO) switch, disconnecting switch, or electrical outlet. If an electrical accident occurs, you can then operate the switch or unplug the power cord quickly.
- Do not work alone under hazardous conditions or near equipment that has hazardous voltages.
- Disconnect all power before:
  - Performing a mechanical inspection
  - Working near power supplies
  - Removing or installing Field Replaceable Units (FRUs)
- Before you start to work on the machine, unplug the power cord. If you cannot unplug it, ask the customer to power-off the wall box that supplies power to the machine and to lock the wall box in the off position.
- If you need to work on a machine that has exposed electrical circuits, observe the following precautions:
  - Ensure that another person, familiar with the power-off controls, is near you.  
**Remember:** Another person must be there to switch off the power, if necessary.
  - Use only one hand when working with powered-on electrical equipment; keep the other hand in your pocket or behind your back.  
**Remember:** There must be a complete circuit to cause electrical shock. By observing the above rule, you may prevent a current from passing through your body.
  - When using a tester, set the controls correctly and use the approved probe leads and accessories for that tester.
  - Stand on suitable rubber mats (obtained locally, if necessary) to insulate you from grounds such as metal floor strips and machine frames.

Observe the special safety precautions when you work with very high voltages; these instructions are in the safety sections of maintenance information. Use extreme care when measuring high voltages.

- Regularly inspect and maintain your electrical hand tools for safe operational condition.
- Do not use worn or broken tools and testers.
- *Never assume* that power has been disconnected from a circuit. First, *check* that it has been powered-off.
- Always look carefully for possible hazards in your work area. Examples of these hazards are moist floors, nongrounded power extension cables, power surges, and missing safety grounds.
- Do not touch live electrical circuits with the reflective surface of a plastic dental mirror. The surface is conductive; such touching can cause personal injury and machine damage.
- Do not service the following parts with the power on when they are removed from their normal operating places in a machine:

- Power supply units
  - Pumps
  - Blowers and fans
  - Motor generators
- and similar units. (This practice ensures correct grounding of the units.)

- If an electrical accident occurs:
  - Use caution; do not become a victim yourself.
  - Switch off power.
  - Send another person to get medical aid.

---

## Safety inspection guide

The intent of this inspection guide is to assist you in identifying potentially unsafe conditions on these products. Each machine, as it was designed and built, had required safety items installed to protect users and service personnel from injury. This guide addresses only those items. However, good judgment should be used to identify potential safety hazards due to attachment of features or options not covered by this inspection guide.

If any unsafe conditions are present, you must determine how serious the apparent hazard could be and whether you can continue without first correcting the problem.

Consider these conditions and the safety hazards they present:

- Electrical hazards, especially primary power (primary voltage on the frame can cause serious or fatal electrical shock).
- Explosive hazards, such as a damaged CRT face or bulging capacitor
- Mechanical hazards, such as loose or missing hardware

The guide consists of a series of steps presented in a checklist. Begin the checks with the power off, and the power cord disconnected.

Checklist:

1. Check exterior covers for damage (loose, broken, or sharp edges).
2. Power-off the computer. Disconnect the power cord.
3. Check the power cord for:
  - a. A third-wire ground connector in good condition. Use a meter to measure third-wire ground continuity for 0.1 ohm or less between the external ground pin and frame ground.
  - b. The power cord should be the appropriate type as specified in the parts listings.
  - c. Insulation must not be frayed or worn.
4. Remove the cover.
5. Check for any obvious alterations. Use good judgment as to the safety of any alterations.
6. Check inside the unit for any obvious unsafe conditions, such as metal filings, contamination, water or other liquids, or signs of fire or smoke damage.
7. Check for worn, frayed, or pinched cables.
8. Check that the power-supply cover fasteners (screws or rivets) have not been removed or tampered with.

---

## Handling electrostatic discharge-sensitive devices

Any computer part containing transistors or integrated circuits (ICs) should be considered sensitive to electrostatic discharge (ESD). ESD damage can occur when there is a difference in charge between objects. Protect against ESD damage by equalizing the charge so that the machine, the part, the work mat, and the person handling the part are all at the same charge.

### Notes:

1. Use product-specific ESD procedures when they exceed the requirements noted here.
2. Make sure that the ESD protective devices you use have been certified (ISO 9000) as fully effective.

When handling ESD-sensitive parts:

- Keep the parts in protective packages until they are inserted into the product.
- Avoid contact with other people while handling the part.
- Wear a grounded wrist strap against your skin to eliminate static on your body.
- Prevent the part from touching your clothing. Most clothing is insulative and retains a charge even when you are wearing a wrist strap.
- Use the black side of a grounded work mat to provide a static-free work surface. The mat is especially useful when handling ESD-sensitive devices.
- Select a grounding system, such as those listed below, to provide protection that meets the specific service requirement.

**Note:** The use of a grounding system is desirable but not required to protect against ESD damage.

- Attach the ESD ground clip to any frame ground, ground braid, or green-wire ground.
- Use an ESD common ground or reference point when working on a double-insulated or battery-operated system. You can use coax or connector-outside shells on these systems.
- Use the round ground-prong of the ac plug on ac-operated computers.

---

## Grounding requirements

Electrical grounding of the computer is required for operator safety and correct system function. Proper grounding of the electrical outlet can be verified by a certified electrician.

---

## Safety notices (multi-lingual translations)

The caution and danger safety notices in this section are provided in the following languages:

- English
- Arabic
- Brazilian/Portuguese
- Chinese (simplified)
- Chinese (traditional)
- French
- German
- Hebrew
- Italian
- Korean

- Spanish



**DANGER**

Electrical current from power, telephone and communication cables is hazardous.

**To avoid a shock hazard:**

- **Do not connect or disconnect any cables or perform installation, maintenance, or reconfiguration of this product during an electrical storm.**
- **Connect all power cords to a properly wired and grounded electrical outlet.**
- **Connect to properly wired outlets any equipment that will be attached to this product.**
- **When possible, use one hand only to connect or disconnect signal cables.**
- **Never turn on any equipment when there is evidence of fire, water, or structural damage.**
- **Disconnect the attached power cords, telecommunications systems, networks, and modems before you open the device covers, unless instructed otherwise in the installation and configuration procedures.**
- **Connect and disconnect cables as described in the following tables when installing, moving, or opening covers on this product or attached devices.**

To Connect	To Disconnect
1. Turn everything OFF. 2. First, attach all cables to devices. 3. Attach signal cables to connectors. 4. Attach power cords to outlet. 5. Turn device ON.	1. Turn everything OFF. 2. First, remove power cords from outlet. 3. Remove signal cables from connectors. 4. Remove all cables from devices.



**CAUTION:**

If your system has a module containing a lithium battery, replace it only with the same module type made by the same manufacturer. The battery contains lithium and can explode if not properly used, handled, or disposed of. *Do not:*

- **Throw or immerse into water**
- **Heat to more than 100°C (212°F)**
- **Repair or disassemble**

Dispose of the battery as required by local ordinances or regulations.



**CAUTION:**

When laser products (such as CD-ROMs, DVD-ROM drives, fiber optic devices, or transmitters) are installed, note the following:

- Do not remove the covers. Removing the covers of the laser product could result in exposure to hazardous laser radiation. There are no serviceable parts inside the device.
- Use of controls or adjustments or performance of procedures other than those specified herein might result in hazardous radiation exposure.



Some laser products contain an embedded Class 3A or Class 3B laser diode. Note the following: Laser radiation when open. Do not stare into the beam, do not view directly with optical instruments, and avoid direct exposure to the beam.



≥18 kg (37 lb)



≥32 kg (70.5 lb)

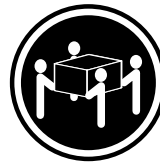

≥55 kg (121.2 lb)

**CAUTION:**  
Use safe practices when lifting.



**CAUTION:**  
The power control button on the device and the power switch on the power supply do not turn off the electrical current supplied to the device. The device also might have more than one power cord. To remove all electrical current from the device, ensure that all power cords are disconnected from the power source.

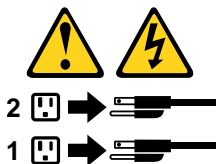

التيار الكهربائي الموجود بمصدر الطاقة أو أجهزة التليفون أو أسلاك الاتصالات يشكل خطورة.

لتفادي مخاطر الصدمات الكهربائية:

لا تحاول توصيل أو فصل أي أسلاك أو القيام بعمليات تركيب أو صيانة أو إعادة توصيف لهذا المنتج أثناء وجود عاصفة كهربائية.

يجب توصيل كل أسلاك الكهرباء في مخارج كهرباء ذات توصيلات أسلاك وتوصيلات أرضية صحيحة  
يجب توصيل أي جهاز سيتم الحاقه بهذا المنتج في مخارج كهرباء ذات توصيلات أسلاك صحيحة.

وإن أمكن يجب استخدام يد واحدة فقط في توصيل أو فصل أسلاك الإشارة.

لا تحاول تشغيل أي جهاز إذا كان هناك أثر لحرق أو مياه أو تلف بالمكونات

يجب فصل أسلاك الكهرباء وأنظمة الاتصالات وشبكات الاتصال وأجهزة المودم الملحقة قبل فتح أغطية الجهاز، مالم يتم طلب خلاف ذلك في التعليمات الخاصة بالتركيب والتوصيف.  
قم بتوصيل وفصل الأسلاك كما هو موضح في الجدول التالي وذلك عند القيام بعمليات التركيب أو النقل أو فتح أغطية هذا المنتج أو الأجهزة الملحقة.

#### للفصل:

- قم بإيقاف كل شيء.
- أولاً، قم بفصل كل أسلاك الكهرباء من المخرج.
- قم بفصل أسلاك الإشارة من الموصلات.
- قم بفصل كل الأسلاك من الأجهزة.

#### للتوصيل:

- قم بإيقاف كل شيء.
- أولاً، قم بتوصيل كل الأسلاك بالأجهزة.
- قم بتوصيل أسلاك الإشارة في لموصلات.
- قم بتوصيل أسلاك الكهرباء في المخارج.
- قم بتشغيل الجهاز.



#### تنبيه :

إذا كان النظام الخاص يستخدم معه بطارية ليثيوم قم باستبدالها بنفس النوع الذي تم صنعته من خلال نفس المصنع. تحتوي البطارية على مادة الليثيوم ويمكن أن تنفجر في حالة عدم استخدامها أو التعامل معها بطريقة صحيحة أو عند التخلص منها بطريقة خطأ.

لا تقم بـ:

- القاء البطارية أو غمرها في الماء
- تسخينها أعلى من ١٠٠ درجة مئوية و(٢١٢ ° فهرنهايت)
- بتصلحها أو فكها

تخلص من البطارية طبقاً للقانون أو النظام المحلي .



تنبيه :  
أثناء تركيب منتجات ليزر (مثل CD-ROMs أو وحدة تشغيل DVD أو أجهزة Fiber Optic أو وحدات الإرسال) يجب مراعاة الآتي:

لا تنزع الأغطية. قد ينتج عن نزع أغطية منتج الليزر انفجار أشعة الليزر شديدة الخطورة.  
لا يوجد أجزاء يمكن تغييرها داخل الجهاز. قد ينتج عن استخدام تحكيمات أو تعديلات أو عمل أي تصرفات أخرى تخالف ما هو محدد هنا إلى انفجار أشعة شديدة الخطورة.



خطر

تحتوي بعض منتجات الليزر على الفئة دايود ليزر مدمج من الفئة Class 3A أو Class 3B. يجب مراعاة الآتي .

أشعة الليزر عند الفتح. لا تحديق إلى الإشعاع و لا تنظر اليه مباشرة بواسطة أي أجهزة مرئية وتجنب التعرض المباشر للإشعاع .

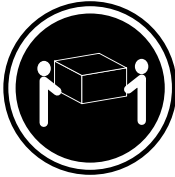

≥18 kg (37 lb)



≥32 kg (70.5 lb)

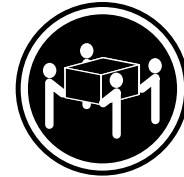

≥55 kg (121.2 lb)

تنبيه :  
يجب استخدام ممارسات أمانة عند الرفع



تنبيه :

لا يرقم زر التحكم في التشغيل الموجود على الجهاز والمفتاح الكهربائي الموجود على لوحة التحكم بإيقاف التيار الكهربائي المار بالجهاز. قد يكون للجهاز أكثر من سلك كهربائي واحد. لإيقاف التيار الكهربائي المار بالجهاز، تأكد من فصل جميع أسلاك الكهرباء من مصدر الكهرباء .

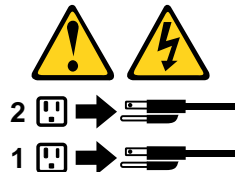



## PERIGO

A corrente elétrica proveniente de cabos de alimentação, de telefone e de comunicações é perigosa.

Para evitar risco de choque elétrico:

- Não conecte nem desconecte nenhum cabo ou execute instalação, manutenção ou reconfiguração deste produto durante uma tempestade com raios.
- Conecte todos os cabos de alimentação a tomadas elétricas corretamente instaladas e aterradas.
- Todo equipamento que for conectado a este produto deve ser conectado a tomadas corretamente instaladas.
- Quando possível, utilize apenas uma das mãos para conectar ou desconectar cabos de sinal.
- Nunca ligue nenhum equipamento quando houver evidência de fogo, água ou danos estruturais.
- Antes de abrir tampas de dispositivos, desconecte cabos de alimentação, sistemas de telecomunicação, redes e modems conectados, a menos que especificado de maneira diferente nos procedimentos de instalação e configuração.
- Conecte e desconecte os cabos conforme descrito na tabela apresentada a seguir ao instalar, mover ou abrir tampas deste produto ou de dispositivos conectados.

Para Conectar:	Para Desconectar:
<ol style="list-style-type: none"><li>1. DESLIGUE Tudo.</li><li>2. Primeiramente, conecte todos os cabos aos dispositivos.</li><li>3. Conecte os cabos de sinal aos conectores.</li><li>4. Conecte os cabos de alimentação às tomadas.</li><li>5. LIGUE os dispositivos.</li></ol>	<ol style="list-style-type: none"><li>1. DESLIGUE Tudo.</li><li>2. Primeiramente, remova os cabos de alimentação das tomadas.</li><li>3. Remova os cabos de sinal dos conectores.</li><li>4. Remova todos os cabos dos dispositivos.</li></ol>



## CUIDADO:

**Se o seu sistema possui um módulo com uma bateria de lítio, substitua-o apenas por um módulo do mesmo tipo e do mesmo fabricante. A bateria contém lítio e pode explodir se não for utilizada, manuseada ou descartada de maneira correta.**

Não:

- Jogue ou coloque na água
- Aqueça a mais de 100°C (212°F)
- Conserte nem desmonte

Descarte a bateria conforme requerido pelas leis ou regulamentos locais.



## PRECAUCIÓN:

Quando produtos a laser (como unidades de CD-ROMs, unidades de DVD-ROM, dispositivos de fibra ótica ou transmissores) estiverem instalados, observe o seguinte:

- Não remova as tampas. A remoção das tampas de um produto a laser pode resultar em exposição prejudicial à radiação de laser. Não existem peças que podem ser consertadas no interior do dispositivo.
- A utilização de controles ou ajustes ou a execução de procedimentos diferentes dos especificados aqui pode resultar em exposição prejudicial à radiação.

## PERIGO

Alguns produtos a laser contêm diodo de laser integrado da Classe 3A ou da Classe 3B. Observe o seguinte:

Radiação a laser quando aberto. Não olhe diretamente para o feixe a olho nu ou com instrumentos ópticos e evite exposição direta ao feixe.



≥18 kg (37 lb)



≥32 kg (70.5 lb)

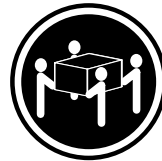

≥55 kg (121.2 lb)

## CUIDADO:

Utilize procedimentos de segurança para levantar equipamentos.



## CUIDADO:

O botão de controle de alimentação do dispositivo e o botão para ligar/desligar da fonte de alimentação não desligam a corrente elétrica fornecida ao dispositivo. O dispositivo também pode ter mais de um cabo de alimentação. Para remover toda a corrente elétrica do dispositivo, assegure que todos os cabos de alimentação estejam desconectados da fonte de alimentação.

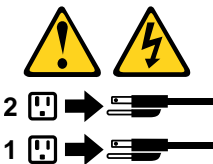

危险

电源、电话和通信电缆中的电流是危险的。

为避免电击危险：

- 请勿在雷电期间连接或断开任何电缆的连接，或者对本产品进行安装、维护或重新配置。
- 将所有电源线连接到正确连线和妥善接地的电源插座。
- 将所有要连接到该产品的设备连接到正确连线的插座。
- 如果可能，请仅使用一只手来连接或断开信号电缆的连接。
- 切勿在有火、水、结构损坏迹象的情况下开启任何设备。
- 在打开设备外盖之前请断开已连接的电源线、远程通信系统、网络和调制解调器，除非在安装和配置过程中另有说明。
- 当安装、移动或打开该产品或连接设备的外盖时，请按照下表所述来连接或断开电缆的连接。

要连接	要断开连接
<ol style="list-style-type: none"> <li>1. 切断所有电源。</li> <li>2. 首先将所有电缆连接到设备。</li> <li>3. 将信号电缆连接到接口。</li> <li>4. 将电源线连接到插座。</li> <li>5. 开启设备。</li> </ol>	<ol style="list-style-type: none"> <li>1. 切断所有电源。</li> <li>2. 首先从插座上拔出电源线。</li> <li>3. 从接口上拔出信号电缆。</li> <li>4. 从设备上拔出所有电缆。</li> </ol>



警告：  
如果您的系统有包含锂电池的模块，请仅使用同一制造商生产的相同模块类型来替换该模块。该电池中含有锂，如果使用、操作或处理不当，可能会发生爆炸。

切勿：

- 投入或浸入水中
- 加热到 100 °C (212 °F) 以上
- 维修或拆卸

请按照当地法令或条例的要求处理电池。



警告：  
安装激光产品（例如 CD-ROM、DVD-ROM 驱动器、光纤设备或发射设备）时，请注意以下声明：

- 请勿卸下外盖。卸下激光产品的外盖可能导致遭受激光辐射的危险。该设备内没有可维修的部件。
- 如果不按照此处指定的过程进行控制、调整或操作，则有可能导致遭受辐射的危险。



危险

某些激光产品包含嵌入式 3A 类或 3B 类激光二极管。请注意以下声明：

打开后有激光辐射。请勿注视光束，请勿直接用光学仪器查看，并请避免直接暴露在光束中。



≥18 千克 (37 磅)    ≥32 千克 (70.5 磅)    ≥55 千克 (121.2 磅)

警告：  
抬起时请采取安全措施。



警告：  
设备上的电源控制按钮和电源上的电源开关不会切断供给该设备的电流。该设备还可能有多条电源线。要切断该设备的所有电流，请确保所有电源线都与电源断开连接。

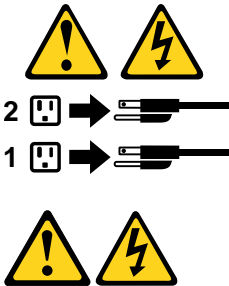

## 危險

電源、電話及通訊纜線上的電流都具有危險性。

若要避免觸電危險：

- 請勿在雷雨期間，連接或拔除纜線、執行安裝、維護或重新配置本產品。
- 將所有電源線連接到正確配線及接地的電源插座。
- 任何與本產品連接的設備都必須連接到配線妥當的電源插座。
- 請盡可能用單手連接或拔除信號線。
- 發生火災、水災或結構損害時，絕對不要開啟任何設備。
- 除非在安裝及配置程序中另有指示，否則在開啟裝置機蓋之前，請拔掉連接的電源線、電信系統、網路及數據機。
- 安裝、移動或開啟本產品或附屬裝置的機蓋時，請遵循下列說明連接及拔掉纜線。

連線	切斷連線
<ol style="list-style-type: none"><li>1. 關閉所有開關。</li><li>2. 首先，連接所有接線到裝置。</li><li>3. 連接信號線到接頭。</li><li>4. 連接電源線到插座。</li><li>5. 開啟裝置。</li></ol>	<ol style="list-style-type: none"><li>1. 關閉所有開關。</li><li>2. 首先，拔掉插座上的電源線。</li><li>3. 拔掉接頭上的信號線。</li><li>4. 拔掉裝置上所有接線。</li></ol>



### 警告：

如果您的系統中含有鋰電池模組，請僅使用同一家製造商所生產的相同模組進行更換。如果未以正確方式使用、處理或棄置含鋰的電池，會有爆炸的危險。

請勿：

- 沾溼或浸入水中
  - 置於 **100°C (212°F)** 以上的高溫環境
  - 修理或拆開
- 請按照各地區有關廢棄電池的法令和規定處理舊電池。



### 警告：

- 請勿移除機蓋。移除雷射產品的機蓋，可能會導致暴露在危險的雷射輻射中。裝置內部並無可自行維修的零件。
- 利用或執行非本文中所指定的控制、調整及執行程序，可能會導致危險的輻射外洩。



## 危險

部分雷射產品含有內嵌式 **Class 3A** 或 **Class 3B** 雷射二極體。請注意下列事項：

在開啟光碟機時，會發生雷射輻射。請勿直視光束或用光學儀器直接檢視，並避免直接暴露在光束中。



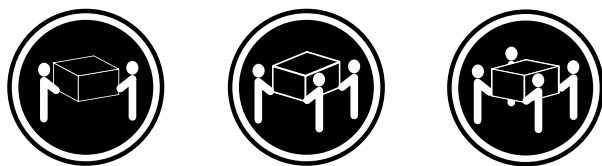

≥ 18 公斤 (37 磅)    ≥ 32 公斤 (70.5 磅)    ≥ 55 公斤 (121.2 磅)

警告：  
搬運時請注意安全。



警告：  
裝置上的電源控制按鈕及電源供應器上的電源開關，無法關閉裝置所產生的電流。  
該裝置可能有多條電源線。若要除去裝置流出的所有電流，請確認已切斷所有電源線的電源。

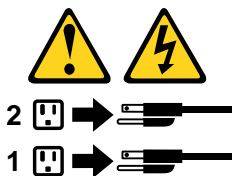

## DANGER

Le courant électrique provenant de l'alimentation, du téléphone et des câbles de transmission peut présenter un danger.

Pour éviter tout risque de choc électrique :

- Ne manipulez aucun câble et n'effectuez aucune opération d'installation, d'entretien ou de reconfiguration de ce produit au cours d'un orage.
- Branchez tous les cordons d'alimentation sur un socle de prise de courant correctement câblé et mis à la terre.
- Branchez sur des socles de prise de courant correctement câblés tout équipement connecté à ce produit.
- Lorsque cela est possible, n'utilisez qu'une seule main pour connecter ou déconnecter les câbles d'interface.
- Ne mettez jamais un équipement sous tension en cas d'incendie ou d'inondation, ou en présence de dommages matériels.
- Avant de retirer les carters de l'unité, mettez celle-ci hors tension et déconnectez ses cordons d'alimentation, ainsi que les câbles qui la relient aux réseaux, aux systèmes de télécommunication et aux modems (sauf instruction contraire mentionnée dans les procédures d'installation et de configuration).
- Lorsque vous installez, que vous déplacez, ou que vous manipulez le présent produit ou des périphériques qui lui sont raccordés, reportez-vous aux instructions ci-dessous pour connecter et déconnecter les différents cordons.

Connexion	Déconnexion
<ol style="list-style-type: none"> <li>1. Mettez les unités HORS TENSION.</li> <li>2. Commencez par brancher tous les cordons sur les unités.</li> <li>3. Branchez les câbles d'interface sur des connecteurs.</li> <li>4. Branchez les cordons d'alimentation sur des prises.</li> <li>5. Mettez les unités SOUS TENSION.</li> </ol>	<ol style="list-style-type: none"> <li>1. Mettez les unités HORS TENSION.</li> <li>2. Débranchez les cordons d'alimentation des prises.</li> <li>3. Débranchez les câbles d'interface des connecteurs.</li> <li>4. Débranchez tous les câbles des unités.</li> </ol>



**ATTENTION:**

**Si votre système est doté d'un module contenant une pile au lithium, vous devez le remplacer uniquement par un module identique, produit par le même fabricant. La pile contient du lithium et peut exploser en cas de mauvaise utilisation, de mauvaise manipulation ou de mise au rebut inappropriée.**

Ne pas :

- la jeter à l'eau,
- l'exposer à des températures supérieures à 100°C,
- chercher à la réparer ou à la démonter.

**Ne pas mettre la pile à la poubelle. Pour la mise au rebut, se reporter à la réglementation en vigueur.**



**ATTENTION:**

**Si des produits à laser (tels que des unités de CD-ROM, de DVD-ROM, des unités à fibres optiques, ou des émetteurs) sont installés, prenez connaissance des informations suivantes :**

- **Ne retirez pas le carter. En ouvrant l'unité de CD-ROM ou de DVD-ROM, vous vous exposez au rayonnement dangereux du laser. Aucune pièce de l'unité n'est réparable.**
- **Pour éviter tout risque d'exposition au rayon laser, respectez les consignes de réglage et d'utilisation des commandes, ainsi que les procédures décrites dans le présent manuel.**



**DANGER**

**Certains produits à laser contiennent une diode à laser intégrée de classe 3A ou 3B. Prenez connaissance des informations suivantes:**

**Rayonnement laser lorsque le carter est ouvert. Evitez toute exposition directe au rayon laser. Evitez de regarder fixement le faisceau ou de l'observer à l'aide d'instruments optiques.**

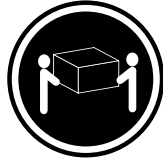

≥18 kg (37 lb)



≥32 kg (70.5 lb)



≥55 kg (121.2 lb)

#### ATTENTION:

Soulevez la machine avec précaution.



#### ATTENTION:

L'interrupteur de contrôle d'alimentation de l'unité et l'interrupteur dubloc d'alimentation ne coupent pas le courant électrique alimentant l'unité. En outre, le système peut être équipé de plusieurs cordons d'alimentation. Pour mettre l'unité hors tension, vous devez déconnecter tous les cordons de la source d'alimentation.

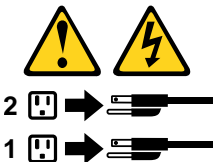

#### VORSICHT

An Netz-, Telefon- und Datenleitungen können gefährliche Spannungen anliegen.

#### Aus Sicherheitsgründen:

- Bei Gewitter an diesem Gerät keine Kabel anschließen oder lösen. Ferner keine Installations-, Wartungs- oder Rekonfigurationsarbeiten durchführen.
- Gerät nur an eine Schutzkontaktsteckdose mit ordnungsgemäß geerdetem Schutzkontakt anschließen.
- Alle angeschlossenen Geräte ebenfalls an Schutzkontaktsteckdosen mit ordnungsgemäß geerdetem Schutzkontakt anschließen.
- Die Signalkabel nach Möglichkeit einhändig anschließen oder lösen, um einen Stromschlag durch Berühren von Oberflächen mit unterschiedlichem elektrischem Potenzial zu vermeiden.

- Geräte niemals einschalten, wenn Hinweise auf Feuer, Wasser oder Gebäudeschäden vorliegen.
- Die Verbindung zu den angeschlossenen Netzkabeln, Telekommunikationssystemen, Netzwerken und Modems ist vor dem Öffnen des Gehäuses zu unterbrechen, sofern in den Installations- und Konfigurationsprozeduren keine anders lautenden Anweisungen enthalten sind.
- Zum Installieren, Transportieren und Öffnen der Abdeckungen des Computers oder der angeschlossenen Einheiten die Kabel gemäß der folgenden Tabelle anschließen und abziehen.

Zum Anschließen der Kabel gehen Sie wie folgt vor	Zum Abziehen der Kabel gehen Sie wie folgt vor
<ol style="list-style-type: none"> <li>1. Schalten Sie alle Einheiten AUS.</li> <li>2. Schließen Sie erst alle Kabel an die Einheiten an.</li> <li>3. Schließen Sie die Signalkabel an die Buchsen an.</li> <li>4. Schließen Sie die Netzkabel an die Steckdose an.</li> <li>5. Schalten Sie die Einheit EIN.</li> </ol>	<ol style="list-style-type: none"> <li>1. Schalten Sie alle Einheiten AUS.</li> <li>2. Ziehen Sie zuerst alle Netzkabel aus den Netzsteckdosen.</li> <li>3. Ziehen Sie die Signalkabel aus den Buchsen.</li> <li>4. Ziehen Sie alle Kabel von den Einheiten ab.</li> </ol>



**CAUTION:**

Enthält das System ein Modul mit einer Lithiumbatterie, dieses nur durch ein Modul desselben Typs und von demselben Hersteller ersetzen. Die Batterie enthält Lithium und kann bei unsachgemäßer Verwendung, Handhabung oder Entsorgung explodieren.

Die Batterie nicht:

- mit Wasser in Berührung bringen.
- über 100 C erhitzen.
- reparieren oder zerlegen.

Die örtlichen Bestimmungen für die Entsorgung von Sondermüll beachten.



**ACHTUNG:**

Bei der Installation von Lasergeräten (wie CD-ROM-Laufwerken, DVD- aufwerken, Einheiten mit Lichtwellenleitertechnik oder Sendern) Folgendes beachten:

- Die Abdeckungen nicht entfernen. Durch Entfernen der Abdeckungen des Lasergeräts können gefährliche Laserstrahlungen freigesetzt werden. Das Gerät enthält keine zu wartenden Teile.
- Werden Steuerelemente, Einstellungen oder Durchführungen von Prozeduren anders als hier angegeben verwendet, kann gefährliche Laserstrahlung auftreten.



**VORSICHT**

Einige Lasergeräte enthalten eine Laserdiode der Klasse 3A oder 3B. Beachten Sie Folgendes:

Laserstrahlung bei geöffneter Verkleidung. Nicht in den Strahl blicken. Keine Lupen oder Spiegel verwenden. Strahlungsbereich meiden.

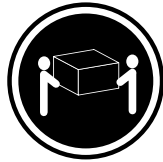

≥18 kg



≥32 kg



≥55 kg

**ACHTUNG:**

Arbeitsschutzrichtlinien beim Anheben der Maschine beachten.



**ACHTUNG:**

Mit dem Netzschalter an der Einheit und am Netzteil wird die Stromversorgung für die Einheit nicht unterbrochen. Die Einheit kann auch mit mehreren Netzkabeln ausgestattet sein. Um die Stromversorgung für die Einheit vollständig zu unterbrechen, müssen alle zum Gerät führenden Netzkabel vom Netz getrennt werden.

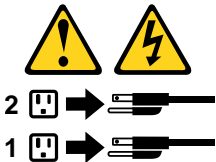

## סכנה

זרם חשמלי המועבר בכבלי חשמל, טלפון ותקשורת הוא מסוכן.

כדי להימנע מסכנת התחשמלות:

- אל תחברו או תנתקו כבלים, ואל תבצעו פעולת התקנה, תחזוקה או שינוי תצורה במוצר זה במהלך סופת ברקים.
- חברו את כל כבלי החשמל לשקע חשמל מחווט ומארק כהלכה.
- חברו כל ציוד שיחובר למוצר זה לשקעי חשמל מחוטים כהלכה.
- במידת האפשר, השתמשו ביד אחת בלבד לחיבור או לניתוק של כבלי אותות.
- לעולם אל תפעילו ציוד כלשהו כאשר יש עדות לנזק מבני או לנזק כתוצאה מאש או ממים.
- נתקו את כבלי החשמל, מערכות התקשורת, התקני הרשת והמודמים המחוברים לפני פתיחת כיסויי ההתקן, אלא אם הליכי ההתקנה וקביעת התצורה מורים אחרת.
- בעת התקנה, העברה או פתיחת כיסויים במוצר זה או בהתקנים המחוברים, חברו ונתקו את הכבלים כמתואר בטבלה שלהלן.

כדי לחבר	כדי לנתק
1. כבו הכל.	1. כבו הכל.
2. ראשית, חברו את כל הכבלים להתקנים.	2. ראשית, נתקו את כבלי החשמל מהשקעים.
3. חברו את כבלי האותות למחברים.	3. נתקו את כבלי האותות מהמחברים.
4. חברו את כבלי החשמל לשקעים.	4. הסירו את כל הכבלים מההתקנים.
5. הפעילו את ההתקן.	



זהירות:

אם המערכת כוללת מודול המכיל סוללת ליתיום, החליפו אותו רק במודול מאותו סוג ומתוצרת אותו יצרן. הסוללה מכילה ליתיום, ועלולה להתפוצץ אם לא משתמשים ומטפלים בה או משליכים אותה כראוי.

לעולם:

- אל תטבלו במים
  - אל תחממו לטמפרטורה הגבוהה מ-100°C (212°F)
  - אל תתקנו או תפרקו
- השליכו את הסוללה כנדרש לפי התקנות והחוקים המקומיים.



זהירות:

בעת התקנת מוצרי ליזר (כגון כונני תקליטורים ו-DVD, התקני סיב אופטי או משדרים), שימו לב לאזהרות הבאות:

- אל תסירו את הכיסויים. הסרת הכיסויים של מוצר הליזר עלולה לגרום לחשיפה לקרינת ליזר מסוכנת. אין חלקים ברי טיפול בתוך ההתקן.
- שינויים, שימוש בבקורות או ביצוע הליכים אחרים מאלה המתוארים כאן, עלולים לגרום לחשיפה לקרינה מסוכנת.



סכנה

מוצרי ליזר מסוימים מכילים דיודת ליזר מסוג Class 3A או Class 3B. שימו לב לאזהרה הבאה:  
כאשר הוא פתוח, המוצר פולט קרינת ליזר. אל תביטו ישירות בקרן, אל תביטו ישירות בעזרת ציוד אופטי,  
והימענו מחשיפה לקרן.

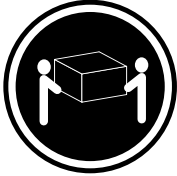

$\leq 18$  ק"ג (37 ליב')



$\leq 32$  ק"ג (70.5 ליב')

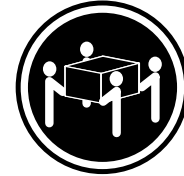

$\leq 55$  ק"ג (121.2 ליב')

זהירות:  
השתמשו בהליכים  
הנאותים בעת  
הרמת הציוד.



זהירות:

לחצן ההפעלה של ההתקן ומתג ההפעלה של ספק החשמל אינם מפסיקים את זרם החשמל המסופק להתקן.  
בנוסף, ההתקן עשוי לכלול יותר מכבל חשמל אחד. כדי לסלק את כל הזרם החשמלי מההתקן,  
ודאו שכל כבלי החשמל מנותקים ממקור החשמל.

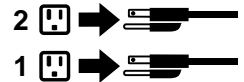

## PERICOLO

La corrente elettrica proveniente dai cavi di alimentazione, del telefono e di comunicazione può essere pericolosa.

**Per evitare il rischio di scosse elettriche:**

- **Non collegare o scollegare qualsiasi cavo oppure effettuare l'installazione, la manutenzione o la riconfigurazione del prodotto durante un temporale.**
- **Collegare tutti i fili elettrici a una presa di alimentazione correttamente cablata e dotata di messa a terra.**
- **Collegare alle prese elettriche appropriate tutte le apparecchiature che verranno utilizzate per questo prodotto.**
- **Se possibile, utilizzare solo una mano per collegare o scollegare i cavi di segnale.**
- **Non accendere assolutamente apparecchiature in presenza di incendi, perdite d'acqua o danno strutturale.**
- **Scollegare i cavi di alimentazione, i sistemi di telecomunicazione, le reti e il modem prima di aprire i coperchi del dispositivo, salvo istruzioni contrarie relative alle procedure di installazione e configurazione.**
- **Collegare e scollegare i cavi come descritto nella seguente tabella quando vengono effettuate operazioni di installazione, spostamento o apertura dei coperchi di questo prodotto o delle unità collegate.**

<b>Per collegarsi</b>	<b>Per scollegarsi</b>
<ol style="list-style-type: none"><li>1. <b>SPEGNERE</b> le apparecchiature.</li><li>2. Innanzitutto, collegare tutti i cavi alle unità.</li><li>3. Collegare i cavi di segnale ai connettori.</li><li>4. Collegare i cavi di alimentazione alla presa.</li><li>5. Accendere l'unità.</li></ol>	<ol style="list-style-type: none"><li>1. <b>SPEGNERE</b> le apparecchiature.</li><li>2. Innanzitutto, rimuovere i cavi di alimentazione dalla presa.</li><li>3. Rimuovere i cavi di segnale dai connettori.</li><li>4. Rimuovere tutti i cavi dalle unità.</li></ol>



**ATTENZIONE:**

**Se sul sistema è presente un modulo che contiene una batteria al litio, sostituirlo solo con un tipo di modulo dello stesso tipo della stessa casa di produzione. La batteria contiene litio e può esplodere se usata, maneggiata o smaltita in modo non corretto.**

*Non:*

- **Gettare o immergere la batteria nell'acqua**
- **Riscaldarla ad una temperatura superiore ai 100 gradi C (212 gradi F)**
- **Smontarla, ricaricarla o tentare di ripararla**

**Le batterie usate vanno smaltite in accordo alla normativa in vigore (DPR 915/82 e successive disposizioni e disposizioni locali).**



**ATTENZIONE:**

**Quando vengono installati prodotti laser (quali CD-ROM, unità DVD-ROM, unità a fibre ottiche o trasmittenti), tener presente quanto segue:**

- Non rimuovere gli sportelli. L'apertura di un'unità laser può determinare l'esposizione a radiazioni laser pericolose. All'interno dell'unità non vi sono parti su cui effettuare l'assistenza tecnica.
- L'utilizzo di controlli, regolazioni o l'esecuzione di procedure non descritti nel presente manuale possono provocare l'esposizione a radiazioni pericolose.



## PERICOLO

Alcune unità laser contengono un diodo laser di Classe 3A o Classe 3B. Tener presente quanto segue:

Aperto l'unità vengono emesse radiazioni laser. Non fissare il fascio, non guardarlo direttamente con strumenti ottici ed evitare l'esposizione al fascio.

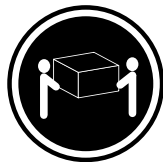

≥18 kg



≥32 kg



≥55 kg

## ATTENZIONE:

Prestare attenzione nel sollevare l'apparecchiatura.



## ATTENZIONE:

Il pulsante di controllo dell'alimentazione presente sull'unità e l'interruttore dell'alimentatore non disattivano l'alimentazione corrente fornita all'unità. E' possibile che l'unità disponga di più cavi di alimentazione. Per disattivare l'alimentazione dall'unità, accertarsi che tutti i cavi di alimentazione siano scollegati dalla fonte di alimentazione.

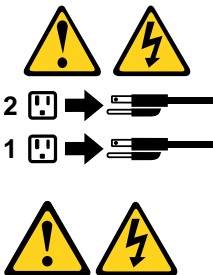

## 위험

전원, 전화, 통신 케이블의 전류는 위험합니다.

감전의 위험을 피하려면 다음과 같이 하십시오.

- 번개가 치는 날에는 케이블을 연결 또는 분리하거나 본 제품을 설치, 보수, 재구성하지 마십시오.
- 모든 전원 코드는 올바르게 접지된 전기 콘센트에 연결하십시오.
- 본 제품에 연결될 장치는 올바르게 배선된 콘센트에 연결하십시오.
- 신호 케이블을 연결 또는 분리할 때 가능하면 한 손만을 사용하십시오.
- 불 또는 물로 인한 손상이나 구조적인 손상이 있을 경우 장치의 전원을 절대 켜지 마십시오.
- 설치 및 구성 과정에 별도의 지시 사항이 없는 경우, 장치의 덮개를 열기 전에 연결된 전원 코드, 원격 통신 시스템, 네트워크, 모뎀을 분리하십시오.
- 본 제품이나 연결된 장치를 설치, 이동하거나 덮개를 열 때 다음 표와 같은 순서로 케이블을 연결하거나 분리하십시오.

연결할 때:	분리할 때:
<ol style="list-style-type: none"><li>1. 모든 장치의 전원을 끄십시오.</li><li>2. 먼저 모든 케이블을 장치에 연결하십시오.</li><li>3. 커넥터에 신호 케이블을 연결하십시오.</li><li>4. 콘센트에 전원 코드를 연결하십시오.</li><li>5. 장치의 전원을 켜십시오.</li></ol>	<ol style="list-style-type: none"><li>1. 모든 장치의 전원을 끄십시오.</li><li>2. 먼저 콘센트에서 전원 코드를 분리하십시오.</li><li>3. 커넥터에서 신호 케이블을 분리하십시오.</li><li>4. 장치에서 모든 케이블을 분리하십시오.</li></ol>



## 주의:

사용자의 시스템이 리튬 배터리를 포함하는 모듈일 경우, 동일한 제조업체에서 동일한 모듈 유형으로 생산된 제품으로 교체하십시오. 배터리에는 리튬이 함유되어 있어 잘못 사용, 취급 또는 폐기할 경우 폭발의 위험이 있습니다.

사고를 방지하려면 다음 사항을 준수하십시오.

- 배터리를 물 속에 던지거나 침수시키지 마십시오.
- 100℃ (212°F) 이상 가열하지 마십시오.
- 수리하거나 분해하지 마십시오.

배터리를 폐기할 때는 법령 또는 회사의 안전 수칙에 따라 폐기하십시오.



## 주의:

CD-ROM, DVD-ROM 장치, 광섬유 장치 또는 송신 장치와 같은 레이저 제품을 설치할 때, 다음과 같은 취급 주의사항을 참고하십시오.

- 덮개를 열지 마십시오. 덮개를 열면 레이저 복사 에너지에 노출될 위험이 있습니다. 장치 내부에는 사용자가 조정하거나 수리할 수 있는 부품이 없습니다.
- 규정된 것 이외의 절차 수행, 제어 조정 등의 행위로 인해 해로운 레이저 복사에 노출될 수 있습니다.



## 위험

일부 장비에는 임베디드 클래스 3A 또는 클래스 3B 레이저 다이오드가 있습니다. 다음 주의사항에 유의하십시오.

드라이브가 열리면 레이저 복사 에너지가 방출됩니다. 광선이 눈에 직접 쏘이지 않도록 하십시오. 나안 또는 광학 기구를 착용한 상태에서 광선을 직접 바라보지 않도록 하십시오.

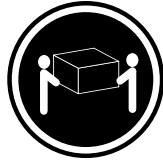

≥ 18 kg (37 lbs)



≥ 32 kg (70.5 lbs)



≥ 55 kg (121.2 lbs)

주의:  
제품을 들어 올릴 때  
안전 규제를 따르십시오.



주의:  
장치의 전원 제어 버튼 및 전원 공급 장치의 전원 스위치를 사용하여 장치에 공급되는 전기를 차단하지 마십시오.  
장치는 둘 이상의 코드를 가지고 있을 수 있습니다. 장치에서 모든 전원을 차단하려면 콘센트에서 코드가 모두 분리되어 있는지 확인하십시오.

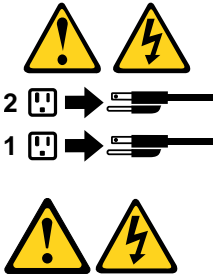

## PELIGRO

La corriente eléctrica procedente de cables de alimentación, teléfonos y cables de comunicación puede ser peligrosa.

**Para evitar el riesgo de descarga eléctrica:**

- **No conecte ni desconecte los cables ni realice ninguna tarea de instalación, mantenimiento o reconfiguración de este producto durante una tormenta eléctrica.**
- **Conecte todos los cables de alimentación a tomas de corriente debidamente cableadas y conectadas a tierra.**
- **Cualquier equipo que se conecte a este producto también debe conectarse a tomas de corriente debidamente cableadas.**

- Siempre que sea posible, utilice una sola mano para conectar o desconectar los cables de señal.
- No encienda nunca un equipo cuando hay señales de fuego, agua o daños estructurales.
- Desconecte los cables de alimentación, los sistemas de telecomunicaciones, las redes y los módems conectados antes de abrir las cubiertas de los dispositivos, a menos que se indique lo contrario en los procedimientos de instalación y configuración.
- Conecte y desconecte los cables, como se describe en la tabla siguiente, cuando instale, mueva o abra las cubiertas de este producto o de los dispositivos conectados.

Para conectar	Para desconectar
<ol style="list-style-type: none"> <li>1. APÁGUELO todo.</li> <li>2. En primer lugar, conecte todos los cables a los dispositivos.</li> <li>3. Conecte los cables de señal a los conectores.</li> <li>4. Enchufe los cables de alimentación a las tomas de corriente.</li> <li>5. Encienda el dispositivo.</li> </ol>	<ol style="list-style-type: none"> <li>1. APÁGUELO todo.</li> <li>2. En primer lugar, desenchufe los cables de alimentación de las tomas de corriente.</li> <li>3. Desconecte los cables de señal de los conectores.</li> <li>4. Desconecte todos los cables de los dispositivos.</li> </ol>



#### PRECAUCIÓN:

Si su sistema dispone de un módulo que contiene una batería de litio, reemplácelo sólo con el mismo tipo de módulo, del mismo fabricante. La batería contiene litio y puede explotar si no se utiliza, manipula o desecha correctamente.

*No debe:*

- Arrojarla al agua o sumergirla en ella
- Exponerla a temperaturas superiores a 100°C (212°F)
- Repararla o desmontarla

Deshágase de la batería según especifiquen las leyes o normas locales.



#### PRECAUCIÓN:

Cuando haya productos láser (como unidades de CD-ROM, unidades de DVD, dispositivos de fibra óptica o transmisores) instalados, tenga en cuenta lo siguiente:

- No quite las cubiertas. Si quita las cubiertas del producto láser, podría quedar expuesto a radiación láser peligrosa. Dentro del dispositivo no existe ninguna pieza que requiera servicio técnico.
- Si usa controles o ajustes o realiza procedimientos que no sean los especificados aquí, podría exponerse a radiaciones peligrosas.



## PELIGRO

Algunos productos láser tienen incorporado un diodo láser de clase 3A o clase 3B. Tenga en cuenta lo siguiente:

Cuando se abre, queda expuesto a radiación láser. No mire directamente al rayo láser, ni siquiera con instrumentos ópticos, y evite exponerse directamente al rayo láser.



≥18 kg



≥32 kg

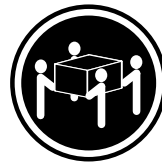

≥55 kg

## PRECAUCIÓN:

Adopte procedimientos seguros al levantar el equipo.



## PRECAUCIÓN:

El botón de control de alimentación del dispositivo y el interruptor de alimentación de la fuente de alimentación no desconectan la corriente eléctrica suministrada al dispositivo. Además, el dispositivo podría tener más de un cable de alimentación. Para suprimir toda la corriente eléctrica del dispositivo, asegúrese de que todos los cables de alimentación estén desconectados de la toma de corriente.

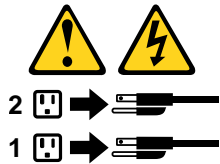

---

## Chapter 2. Important service information

---

### Strategy for replacing FRUs

#### Before replacing parts:

Ensure that all software fixes, drivers, and UEFI BIOS downloads are installed before you replace any FRUs listed in this manual.

After a system board is replaced, ensure that the latest UEFI BIOS is loaded to the system board before you complete the service action.

To download and install software fixes, drivers, and UEFI BIOS, go to <https://pcsupport.lenovo.com> and follow the instructions on the screen.

Use the following strategy to prevent unnecessary expense for replacing and servicing FRUs:

- If you are instructed to replace a FRU but the replacement does not correct the problem, reinstall the original FRU before you continue.
- Some computers have both a processor board and a system board. If you are instructed to replace either the processor board or the system board, and replacing one of them does not correct the problem, reinstall that board, and then replace the other one.
- If an adapter or a device consists of more than one FRU, any of the FRUs might be the cause of the error. Before replacing the adapter or device, remove the FRUs, one by one, to see if the symptoms change. Replace only the FRU that changed the symptoms.

### Strategy for replacing a hard disk drive or a solid-state drive

Always try to run a low-level format operation before replacing a hard disk drive or a solid-state drive. This will cause all customer data on the drive to be lost. Ensure that the customer has a current backup of the data before you perform this task.

**Attention:** The drive startup sequence in the computer you are servicing might have been changed. Be extremely careful during write operations such as copying, saving, or formatting. If you select an incorrect drive, data or programs can be overwritten.

### Important notice for replacing a system board

Some components mounted on a system board are very sensitive. Improper handling of a system board can cause damage to those components, and may cause a system malfunction.

After replacing the system board, the recommended option is to download the latest UEFI BIOS package from Lenovo Support Web site to bind the model type, serial number, and Brand ID of the computer with the new system board. Or use Golden Key U1 tool to bind the new system board. Refer to <https://support.lenovo.com/solutions/ht102004> for instructions.

**Attention:** When handling a system board:

- Do not drop a system board or apply any excessive force to it.
- Avoid rough handling of any kind.
- Avoid bending a system board and hard pushing to prevent cracking at each Ball Grid Array (BGA) chipset.

## How to use error codes

Use the error codes displayed on the screen to diagnose failures. If more than one error code is displayed, begin the diagnosis with the first error code. Whatever causes the first error code might also cause false error codes. If no error code is displayed, see whether the error symptom is listed in the “Symptom-to-FRU Index” section.

---

## Strategy for replacing FRUs for CTO, special-bid, and standard models

This topic provides information about the model types and FRU identification.

### Product definition

This topic introduces different model types and how to identify each type.

#### Dynamic Configure To Order (CTO) model

This model provides the ability for a customer to configure a Lenovo solution from a Web site, and have this configuration sent to fulfillment, where it is built and shipped directly to the customer. The machine label and eSupport will load these products as the 4-character MT, 4-character model, and 2-character country code. The model is “CTO1” and the default country code is “WW” (example: 20AACTO1WW).

#### Special-bid model

This model is a unique configuration that has been negotiated between Lenovo and the customer. A unique MTM consists of a 4-character MT, a 4-character model, and a numeric 2-character country code is provided to the customer to place orders (example: 20AA000955). The country code assigned is numeric and does not designate a specific country or region. The custom model factsheet for the MTM indicates which country the special-bid MTM is set up for. Special-bid offering is not generally announced.

#### Standard model

Standard models (fixed configuration) are announced and offered to all customers. The MTM portion of the machine label consists of a 4-character MT, a 4-character model, and an alphabetic 2-character country code. The country code assigned is alphabetic and represents a designated country or region (example: 20AA0009UK).

## FRU identification

To identify FRUs for a product, do the following:

1. Go to: <https://support.lenovo.com/partslookup>.
2. Type the Machine Type in the corresponding field to get a general FRU list, or type the Serial Number for more detailed FRU information.

---

## Chapter 3. Product overview

---

### Front

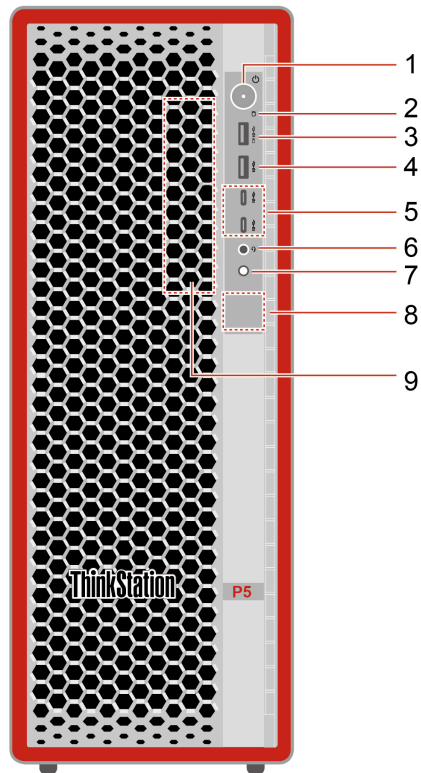

Item	Description	Item	Description
1	Power button with power indicator	2	Storage indicator
3	Always on USB-A 3.2 Gen 2 connector*	4	USB-A 3.2 Gen 2 connector*
5	USB-C (3.2 Gen 2) connectors*	6	Combo audio jack
7	Diagnostic LCD switch	8	Diagnostic LCD
9	Flex bay*		

\* for selected models

## Rear

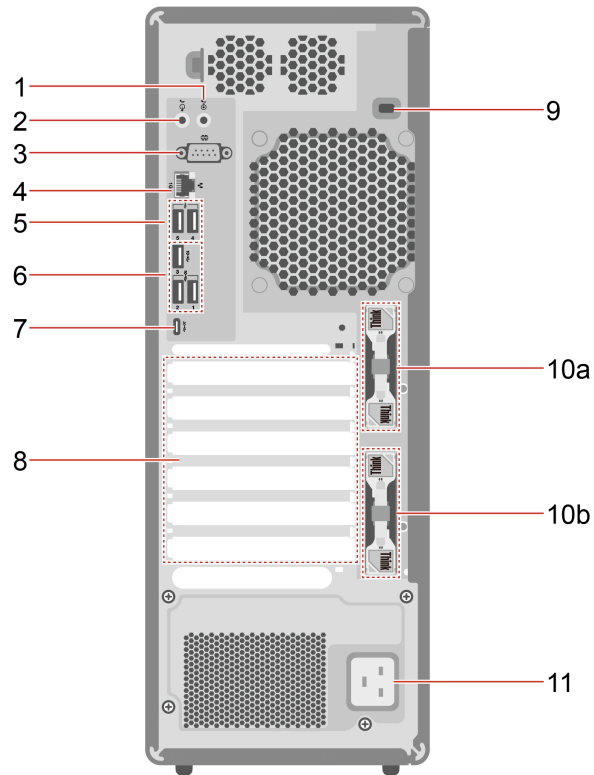

Item	Description	Item	Description
1	Audio line-in connector	2	Audio line-out connector
3	Serial connector*	4	Ethernet connector (1G)
5	USB-A 2.0 connectors	6	USB-A 3.2 Gen 2 connectors
7	USB-C (3.2 Gen 2x2) connector	8	PCI-Express card area
9	Security-lock slot	10a	Key-nest for the side cover*
10b	Key-nest for the M.2 solid-state drive in flex module*	11	Power connector

\* for selected models

### USB-C (3.2 Gen 2x2) connector

Do not connect your external display to the USB-C connector on the rear panel. Otherwise, the external display will not work and the USB-C connector may get damaged.

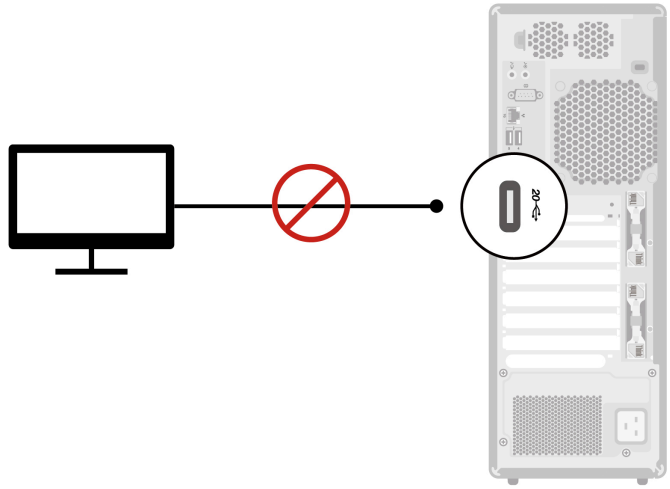

---

## Chapter 4. Service checkout and symptom-to-FRU index

This chapter provides information about general service checkout and symptom-to-FRU index.

---

### Service checkout

**Attention:** The drives in the computer you are servicing might have been rearranged or the drive startup sequence changed. Be extremely careful during write operations such as copying, saving, or formatting. Data or programs can be overwritten if you select an incorrect drive.

General error messages appear if a problem or conflict is found by a program, the operating system, or both. For an explanation of these messages, refer to the information supplied with that software package.

Use the following procedure to help determine the cause of the problem:

1. Turn off the computer and all external devices.
2. Check all cables and power cords.
3. Set all display controls to the middle position.
4. Turn on all external devices.
5. Turn on the computer.
  - Look for displayed error codes.
  - Listen for beep codes.
  - Look for readable instructions or a main menu on the display.

If you *did not* receive the correct response, proceed to step 6 on page 32.

If you *do* receive the correct response, proceed to step 7 on page 32.

6. Look at the following conditions and follow the instructions:
  - If you hear beep codes during POST, go to “Beep symptoms” on page 34.
  - If the computer displays a POST error, go to “POST error codes” on page 35.
  - If the computer hangs and no error is displayed, continue at step 7 on page 32.
7. Run the Diagnostic programs. See Chapter 6 “Diagnostics” on page 46.
  - If you receive an error, replace the part that the diagnostic program calls out.
  - If the test stops and you cannot continue, replace the last device tested.

### Problem determination tips

Due to the variety of hardware and software combinations that can be encountered, use the following information to assist you in problem determination. If possible, have this information available when requesting assistance from Service Support and Engineering functions.

- Machine type and model
- Processor or hard disk drive upgrades
- Failure symptom
  - Do diagnostics indicate a failure?
  - What, when, where, single, or multiple systems?
  - Is the failure repeatable?
  - Has this configuration ever worked?

- If it has been working, what changes were made prior to its failing?
- Is this the original reported failure?
- Diagnostics version
  - Type and version level
- Hardware configuration
  - Print (print screen) configuration currently in use
  - BIOS level
- Operating system software
  - Type and version level

**Notes:** To eliminate confusion, identical systems are considered identical only if they:

1. Are the exact machine type and models
2. Have the same BIOS level
3. Have the same adapters/attachments in the same locations
4. Have the same address jumpers/terminators/cabling
5. Have the same software versions and levels
6. Have the same Diagnostic Diskettes (version)
7. Have the same configuration options set in the system
8. Have the same setup for the operating system control files

Comparing the configuration and software set-up between “working and non-working” systems will often lead to problem resolution.

## Symptom-to-FRU index

The Symptom-to-FRU index lists error symptoms and possible causes. The most likely cause is listed first. Always begin with “Service checkout” on page 32. This index can also be used to help you decide which FRUs to have available when servicing a computer. If you are unable to correct the problem using this index, go to “Undetermined problems” on page 38.

**Notes:**

- The Symptom-to-FRU index is not specific to any machine type and are applicable to all computers.
- If you have both an error message and an incorrect audio response, diagnose the error message first.
- If you cannot run the diagnostic tests or you get a diagnostic error code when running a test, but did receive a POST error message, diagnose the POST error message first.
- If you did not receive any error message, look for a description of your error symptoms in the first part of this index.

## Hard disk drive boot error

A hard disk drive boot error can have the following causes.

Error	FRU/Action
The start-up drive is not in the boot sequence in configuration.	Check the configuration and ensure that the start-up drive is in the boot sequence.
No operating system installed on the boot drive.	Install an operating system on the boot drive.

Error	FRU/Action
The boot sector on the startup drive is corrupted.	The drive must be formatted. Do the following: <ol style="list-style-type: none"> <li>1. Attempt to back up the data on the failing hard disk drive.</li> <li>2. Using the operating system programs, format the hard disk drive.</li> </ol>
The drive is defective.	Replace the hard disk drive.

## Power supply problems

If you suspect a power problem, use the following procedures.

Check/Verify	FRU/Action
Check the following for proper installation. <ul style="list-style-type: none"> <li>• Power cord</li> <li>• On/Off switch connector</li> <li>• On/Off switch power supply connector</li> <li>• System board power supply connectors</li> <li>• CPU connection</li> </ul>	Reseat connectors
Check the power cord for continuity.	Power cord
Check the power-on switch for continuity.	Power-on switch

## Beep symptoms

Beep symptoms are tones or a series of tones separated by pauses (intervals without sound) during POST.

The following table describes the beep symptoms.

Beep symptom	FRU/Action
<b>2 short beeps:</b> common POST error	Common POST error code. See the detailed failure information in "POST error codes" on page 35.
<b>3 short and 1 long beeps:</b> DRAM memory error	Perform the following actions in order: <ol style="list-style-type: none"> <li>1. Make sure that the memory modules are properly seated in the memory slots.</li> <li>2. Replace the memory modules.</li> <li>3. Replace the system board.</li> </ol>
<b>4 long beeps:</b> insufficient shadow RAM resources for option ROM (error code: 8998) or PCIe/PCI MMIO (memory mapped input/output) resources (error code: 8999)	See the detailed failure information in "POST error codes" on page 35.
<b>2 long and 3 short beeps:</b> graphics card error	Perform the following actions in order: <ol style="list-style-type: none"> <li>1. Make sure that the graphics cards are properly seated in the slots.</li> <li>2. Replace the graphics cards.</li> <li>3. Replace the system board.</li> </ol>

## POST error codes

Each time you turn on the system, it performs a series of tests that check the operation of the system and some options. This series of tests are called the *Power-On Self-Test*, or *POST*. POST checks the following operations:

- Some basic system-board operations
- Memory operation
- Video operation
- Whether the boot drive is working

If the POST detects a problem, an error message appears on the screen. A single problem might cause several error messages to appear. When you correct the cause of the first error message, the other error messages probably will not appear on the screen the next time.

Error code	POST error message	Description/Action
0135	CPU fan failure System fan failure Power fan failure Front fan failure Rear fan failure Auxiliary fan failure ODD fan failure	This error message is displayed when a fan fails and the system might be overheating.  Press F10 to exit.
0162	Setup data integrity check failure	This error indicates the checksum of BIOS Setup data in NVRAM is bad.  In BIOS Setup, the "Save Changes and Exit" operation is needed in order to clear this error.
0164	Memory configuration change has occurred	This error message is displayed when the memory size is changed.  Press F10 to exit.
1762	Storage device configuration change has occurred	This error message is displayed when a hard disk drive change or an optical drive change has been made.  Press F10 to exit.

Error code	POST error message	Description/Action
8998	Not enough shadow RAM resources for OPTION ROM, not all devices initialized. Suggest to remove some add-on cards, or change to UEFI mode in BIOS setup.	<p>This error message is displayed when the shadow RAM resources for option ROM are insufficient.</p> <p>If the legacy option ROM is insufficient, remove some add-in cards.</p> <p>For the system that supports UEFI, set UEFI as the first priority.</p>
8999	Not enough PCIe/PCI MMIO resources. Currently only one video card is enabled. Remove some PCIe cards.	<p>This error message is displayed when the PCIe/PCI MMIO (memory mapped input/output) resources are insufficient.</p> <p>Remove some add-in cards.</p>

## Miscellaneous error conditions

Message/Symptom	FRU/Action
Changing display colors	<b>Display/Monitor</b>
Computer will <i>not</i> power-off. See “Hard disk drive boot error” on page 33.	<ol style="list-style-type: none"> <li>1. Power Switch</li> <li>2. System Board</li> <li>3. Riser card, if installed.</li> </ol>
Computer will <i>not</i> RPL from server	<ol style="list-style-type: none"> <li>1. Ensure that the network is in startup sequence as the first device or the first device after diskette.</li> <li>2. Ensure that the network adapter is enabled for RPL.</li> <li>3. Network adapter (Advise network administrator of new MAC address)</li> </ol>
Computer will <i>not</i> perform a Wake On LAN® (if applicable)	<ol style="list-style-type: none"> <li>1. Check the power supply and signal cable connections to the network adapter.</li> <li>2. Ensure that the operating system settings are set to enable Wake on LAN.</li> <li>3. Ensure that the Wake On LAN feature is enabled in Setup/Configuration.</li> <li>4. Ensure that the network administrator is using the correct MAC address.</li> <li>5. Ensure no interrupt or I/O address conflicts.</li> <li>6. Network adapter (advise network administrator of new MAC address)</li> </ol>
Dead computer. See “Hard disk drive boot error” on page 33.	<ol style="list-style-type: none"> <li>1. Power Supply</li> <li>2. System Board</li> </ol>
Diskette drive in-use light remains on or does not light when drive is active.	<ol style="list-style-type: none"> <li>1. Diskette Drive</li> <li>2. System Board</li> <li>3. Diskette Drive Cable</li> </ol>

Message/Symptom	FRU/Action
Blank screen except for flashing cursor.	<ol style="list-style-type: none"> <li>1. System Board</li> <li>2. Primary Hard Disk Drive</li> <li>3. Hard Disk Drive Cable</li> </ol>
Incorrect memory size during POST	<ol style="list-style-type: none"> <li>1. Run the Memory tests.</li> <li>2. Memory Module</li> <li>3. System Board</li> </ol>
"Insert a Diskette" icon appears with a known-good diagnostics diskette in the first 3.5-inch diskette drive.	<ol style="list-style-type: none"> <li>1. System Board</li> <li>2. Diskette Drive Cable</li> <li>3. Network Adapter</li> </ol>
Intensity or color varies from left to right of characters and color bars	<ol style="list-style-type: none"> <li>1. Display</li> <li>2. Video adapter (if present)</li> <li>3. System Board</li> </ol>
No power or fan not running	<ol style="list-style-type: none"> <li>1. See "Hard disk drive boot error" on page 33.</li> </ol>
Non-system disk or disk error-type message with a known-good diagnostic diskette.	<ol style="list-style-type: none"> <li>1. Diskette Drive</li> <li>2. System Board</li> <li>3. Diskette Drive Cable</li> </ol>
Other display symptoms not listed above (including blank or illegible display)	<ol style="list-style-type: none"> <li>1. Display</li> <li>2. System Board</li> </ol>
Power-on indicator or hard disk drive in-use light not on, but computer works correctly	<ol style="list-style-type: none"> <li>1. Power switch/LED assembly</li> <li>2. System Board</li> </ol>
Printer problems	<ol style="list-style-type: none"> <li>1. Printer</li> <li>2. System Board</li> </ol>
Program loads from the hard disk with a known-good diagnostics diskette in the first 3.5-inch diskette drive	<ol style="list-style-type: none"> <li>1. Run the Setup Utility program and check the Startup sequence.</li> <li>2. Diskette Drive</li> <li>3. Diskette Drive Cable</li> <li>4. System Board</li> <li>5. Power Supply</li> </ol>
RPL computer cannot access programs from its own hard disk.	<ol style="list-style-type: none"> <li>1. If the network administrator is using LCCM Hybrid RPL, check the startup sequence: <ol style="list-style-type: none"> <li>a. <b>First device - network</b></li> <li>b. <b>Second device - hard disk</b></li> </ol> </li> <li>2. Hard disk drive</li> </ol>
RPL computer does not RPL from server	<ol style="list-style-type: none"> <li>1. Check the startup sequence.</li> <li>2. Check the network adapter LED status.</li> </ol>

Message/Symptom	FRU/Action
Serial or parallel connector device failure (system board connector)	<ol style="list-style-type: none"> <li>1. External Device Self-Test OK?</li> <li>2. External Device</li> <li>3. Cable</li> <li>4. System Board</li> </ol>
Serial or parallel connector device failure (adapter connector)	<ol style="list-style-type: none"> <li>1. External Device Self-Test OK?</li> <li>2. External Device</li> <li>3. Cable</li> <li>4. Alternate Adapter</li> <li>5. System Board</li> </ol>
Some or all keys on the keyboard do not work	<ol style="list-style-type: none"> <li>1. Keyboard</li> <li>2. Keyboard Cable</li> <li>3. System Board</li> </ol>

## Undetermined problems

This section provides instructions on how to find out the failing devices or adapters.

1. Turn off the computer.
2. Remove or disconnect the following components (if installed) one at a time.
  - a. External devices (modem, printer, or mouse)
  - b. Any adapters
  - c. Memory modules
  - d. Extended video memory
  - e. External Cache
  - f. External Cache RAM
  - g. Hard disk drive
  - h. Diskette drive
3. Turn on the computer to retest the system.
4. Repeat steps 1 through 3 until you find the failing device or adapter.

If all devices and adapters have been removed, and the problem continues, replace the system board. See Chapter 7 “Hardware replacement” on page 50.

## Recover from a BIOS update failure

1. Remove all media from the drives and turn off all connected devices.
2. Insert the BIOS update disc into the optical drive, and then turn off the computer.
3. Disconnect all power cords from electrical outlets. Then, remove any parts that impede access to the Clear CMOS jumper.
4. Move the jumper from the standard position to the Clear CMOS position.
5. Reconnect the power cords for the computer and the monitor to electrical outlets.
6. Turn on the computer and the monitor. When the computer beeps, the recovery process begins.
7. After the recovery process is completed, the computer will be turned off automatically.

**Note:** Depending on the computer model, the recovery process will take two to three minutes.

8. Disconnect all power cords from electrical outlets.
9. Move the jumper back to the standard position.
10. Reinstall all the parts that have been removed. Then, reconnect the power cords for the computer and the monitor to electrical outlets.
11. Turn on the computer and the monitor. When the logo screen is displayed, press F1 or Fn+F1.
12. To prevent data loss, ensure that BIOS settings are restored to an earlier point.

## Clear CMOS

1. Remove all media from the drives and turn off all connected devices and the computer.
2. Disconnect all power cords from electrical outlets. Then, remove any parts that impede access to the Clear CMOS jumper.
3. Move the jumper from the standard position to the Clear CMOS position.
4. Reconnect the power cords for the computer and the monitor to electrical outlets.
5. Turn on the computer and the monitor. When the computer beeps, wait for approximately 10 seconds.
6. Turn off the computer by holding the power button for approximately four seconds.
7. Disconnect all power cords from electrical outlets.
8. Move the jumper back to the standard position.
9. Reinstall all the parts that have been removed. Then, reconnect the power cords for the computer and the monitor to electrical outlets.
10. Turn on the computer and the monitor. When the logo screen is displayed, press F1 or Fn+F1.
11. To prevent data loss, ensure that BIOS settings are restored to an earlier point.

---

## Chapter 5. RAID

---

### What is RAID

Redundant Array of Independent Disks (RAID) is a technology that provides increased storage functions and reliability through redundancy. It also can improve data storage reliability and fault tolerance compared with single-drive storage systems. Data loss resulting from a drive failure can be prevented by reconstructing missing data from the remaining drives.

When a group of independent physical storage drives is set up to use RAID technology, they are in a RAID array. This array distributes data across multiple storage drives, but the array appears to the host computer as one single storage unit. Creating and using RAID arrays provides high performance, such as the expedited I/O performance, because several drives can be accessed simultaneously.

---

### Configure RAID with Intel RSTe

If your computer comes with the Intel RSTe configuration utility, you can follow the sections below to configure RAID with Intel RSTe.

#### Storage drive requirements for RAID levels

Your computer supports the following RAID levels:

- RAID 0: striped disk array
  - Consists of at least two SATA storage drives
  - Supported strip size: 4 KB, 8 KB, 16 KB, 32 KB, 64 KB, or 128 KB
  - Better performance without fault tolerance
- RAID 1: mirrored disk array
  - Consists of two SATA storage drives
  - Improved reading performance and 100% redundancy
- RAID 5: block-level striped disk array with distributed parity
  - Consists of at least three SATA storage drives
  - Supported strip size: 16 KB, 32 KB, 64 KB, or 128 KB
  - Better performance and fault tolerance

#### Create a RAID volume

**Attention:** All the existing data stored on the selected drives will be erased while the RAID volume is being created.

To create a RAID volume:

1. Enable **RAID** by doing the following:
  - a. Restart the computer. When the logo screen is displayed, press F1 or Fn+F1.
  - b. Select **Devices** → **PCH SATA Configuration** and press Enter.
  - c. Select **Configure SATA as** and press Enter. Then, select **RAID** and press Enter.
  - d. Press F10 or Fn+F10 to save the changes and exit.
2. Enter the BIOS menu again.

3. Select **Advanced** → **Intel RSTe SATA Controller** and press Enter.
4. Select **Create RAID Volume** and press Enter. The Create RAID Volume window is displayed.
5. Select and configure the options one by one.
  - a. **Name:** You can use the default name **Volume0** or type a preferred name for the RAID volume.
  - b. **RAID Level:** You can set the RAID level to one of the following:
    - **RAID0**
    - **RAID1**
    - **RAID5**
  - c. **Select Disks:** Select a storage drive and press Enter. Then, select **X** and press Enter to add it to a group.
  - d. **Strip Size** (if applicable): Select a strip size and press Enter.
  - e. **Capacity:** Customize the capacity of the RAID volume. The default RAID volume is the largest value.
6. Select **Create Volume** and press Enter to create a RAID volume.
7. Exit the BIOS menu.

#### View the information about a RAID volume

To view the information about a RAID volume:

1. Restart the computer. When the logo screen is displayed, press F1 or Fn+F1.
2. Select **Advanced** → **Intel RSTe SATA Controller** and press Enter.
3. Select **RAID Volumes** and press Enter.
4. Select a RAID volume and press Enter to view the detailed information.
5. Press F10 or Fn+F10 to save the changes and exit.

#### Delete a RAID volume

**Attention:** All the existing data stored on the selected drives will be erased after you delete RAID volumes.

To delete a RAID volume:

1. Restart the computer. When the logo screen is displayed, press F1 or Fn+F1.
2. Select **Advanced** → **Intel RSTe SATA Controller** and press Enter.
3. Under **RAID Volumes**, select the RAID volume that you want to delete and press Enter. The RAID VOLUME INFO window is displayed.
4. Select **Delete** under **Volume Actions** and press Enter. When prompted, select **Yes** and press Enter to confirm the deletion of the selected RAID volume.
5. Press F10 or Fn+F10 to save the changes and exit.

---

## Configure RAID with AVAGO MegaRAID Configuration Utility

To configure RAID with AVAGO MegaRAID Configuration Utility, ensure that:

- An AVAGO MegaRAID adapter is installed in your computer.
- The storage drives used for RAID configuration are connected to the installed AVAGO MegaRAID adapter instead of the system board.

## Storage drive requirements for RAID levels

Your computer supports the following RAID levels:

- RAID 0: striped disk array
  - Consists of at least two SATA drives
  - Supported strip size: 64 KB, 128 KB, 256 KB, 512 KB, or 1 MB
  - Better performance without fault tolerance

### CAUTION:

**RAID 0 does not support any data redundancy. Use RAID 0 with caution. If a drive in the RAID 0 array fails, the data will be lost and there is no way to get it recovered.**

- RAID 1: mirrored disk array
  - Consists of two or four SATA drives
  - Improved read performance and 100% redundancy

## Create a RAID volume

**Attention:** All the existing data stored on the selected drives will be erased while the RAID volume is being created.

To create a RAID volume:

1. Restart the computer. When the logo screen is displayed, press F1 or Fn+F1.
2. Select **Advanced** → **AVAGO MegaRAID Configuration Utility** and press Enter.
3. Select **Main Menu** and press Enter.
4. Select **Configuration Management** and press Enter.
5. Select **Create Virtual Drive** and press Enter.
6. Select and configure the options one by one.
  - a. **Select RAID Level:** You can set the RAID level to one of the following:
    - **RAID0**
    - **RAID1**
  - Note:** Some of the RAID levels might not be displayed because the number of installed storage drives and the model of the AVAGO MegaRAID adapter vary.
  - b. **Select Drives From:** Select **Unconfigured capacity** or **Free capacity** depending on your needs and press Enter.
  - c. **Select Drives:** Select a storage drive and press Enter. After selecting all storage drives for creating the RAID volume, select **Apply Changes** and press Enter. When promoted, select **Confirm** and press Enter. Then, select **Yes** and press Enter to save the storage drive selection. Finally, select **OK** and press Enter.
  - d. **Virtual Drive Name:** You can type a preferred name for the volume name.
  - e. **Strip Size** (if applicable): Select a strip size and press Enter.
7. Select **Save Configuration** and press Enter. When promoted, select **Confirm** and press Enter. Then, select **Yes** and press Enter to confirm the creation of the RAID volume.
8. Press F10 or Fn+F10 to save the changes and exit.

## View the information about a RAID volume

To view the information about a RAID volume:

1. Restart the computer. When the logo screen is displayed, press F1 or Fn+F1.
2. Select **Advanced** → **AVAGO MegaRAID Configuration Utility** and press Enter.
3. Select **Main Menu** and press Enter.
4. Select **Virtual Drive Management** and press Enter.
5. Select a RAID volume and press Enter to view the detailed information.
6. Press F10 or Fn+F10 to save the changes and exit.

### Virtual drive state

Virtual drive can be in one of the following states:

State	Display in the output of StorCLI commands	Virtual drive status
<b>Optimal</b>	<b>optl</b>	All members of the virtual drive are online.
<b>Partially Degraded</b>	<b>Pdgd</b>	The virtual drive is capable of sustaining more than one member drive's failure. Currently, only a RAID 6 or RAID 60 virtual drive can be partially degraded.
<b>Degraded</b>	<b>dgrd</b>	One or more member drives have failed. The virtual drive can no longer sustain a subsequent drive failure.
<b>Offline</b>	<b>OfLn</b>	One or more member drives have failed. Virtual drive data has lost.

### CAUTION:

**Continuously monitor the RAID volume status to save drives from undesired data loss. If there is any drive failure, remove the failing drive and install a new one.**

### Delete a RAID volume

**Attention:** All the existing data stored on the selected drives will be erased after you delete RAID volumes.

To delete a RAID volume:

1. Restart the computer. When the logo screen is displayed, press F1 or Fn+F1.
2. Select **Advanced** → **AVAGO MegaRAID Configuration Utility**.
3. Select **Main Menu** and press Enter.
4. Select **Virtual Drive Management** and press Enter.
5. Select the RAID volume that is not needed and press Enter.
6. Under **Operation**, select **Delete Virtual Drive** and press Enter.
7. Select **Go** and press Enter. When prompted, select **Confirm** and press Enter. Then, select **Yes** and press Enter to delete the RAID volume.
8. Press F10 or Fn+F10 to save the changes and exit.

---

## Configure RAID with Intel Virtual RAID on CPU

To configure RAID with the Intel Virtual RAID on CPU configuration utility, ensure that:

- An upgrade key module is connected to the Virtual RAID on CPU (VROC) connector on the system board.
- M.2 solid-state drives are installed in your computer.

## Storage drive requirements for RAID levels

Your computer supports the following RAID levels:

- RAID 0: striped disk array
  - Consists of at least two M.2 solid-state drives
  - Supported strip size: 4 KB, 8 KB, 16 KB, 32 KB, 64 KB, or 128 KB
  - Better performance without fault tolerance
- RAID 1: mirrored disk array
  - Consists of two M.2 solid-state drives
  - Improved reading performance and 100% redundancy
- RAID 10: striped and mirrored disk array (a combination of RAID 0 and RAID 1)
  - Consists of four M.2 solid-state drives
  - Supported strip size: 4 KB, 8 KB, 16 KB, 32 KB, or 64 KB
- RAID 5: block-level striped disk array with distributed parity
  - Consists of at least three M.2 solid-state drives
  - Supported strip size: 16 KB, 32 KB, 64 KB, or 128 KB
  - Better performance and fault tolerance
  - Available only on selected models of upgrade key modules

## Create a RAID volume

**Attention:** All the existing data stored on the selected drives will be erased while the RAID volume is being created.

To create a RAID volume:

1. Enable **VMD** for the selected M.2 solid-state drives by doing the following:
  - a. Restart the computer. When the logo screen is displayed, press F1 or Fn+F1.
  - b. Select **Devices** → **Storage Setup** → **Intel(R) VMD technology** and press Enter.
  - c. Select each menu item and press Enter. Then, select **Enabled** and press Enter.
  - d. Select an occupied M.2 solid-state drive slot as you need and press Enter. Then, select **VMD** and press Enter.
  - e. Press F10 or Fn+F10 to save the changes and exit.
2. Enter the BIOS menu again.
3. Select **Advanced** → **Intel Virtual RAID on CPU** and press Enter.
4. Select **All Intel VMD Controllers** and press Enter.
5. Select **Create Volumes** and press Enter.
6. Select and configure the options one by one.
  - a. **Name:** You can use the default name **Volume0** or type a preferred name for the RAID volume.
  - b. **RAID Level:** You can set the RAID level to one of the following:
    - **RAID0**
    - **RAID1**
    - **RAID10**
    - **RAID5**

**Note:** Some of the RAID levels might not be displayed because the number of installed M.2 solid-state drives and the model of the upgrade key module vary.

- c. **Select Disks:** Select an M.2 solid-state drive and press Enter. Then, select **X** and press Enter to add it to a group.
  - d. **Stripe Size** (if applicable): Select a stripe size and press Enter.
  - e. **Capacity:** Customize the capacity of the RAID volume. The default RAID volume is the largest value.
7. Select **Create Volume** and press Enter to create a RAID volume.
  8. Exit the BIOS menu.

### View the information about a RAID volume

To view the information about a RAID volume:

1. Restart the computer. When the logo screen is displayed, press F1 or Fn+F1.
2. Select **Advanced** → **Intel Virtual RAID on CPU** and press Enter.
3. Select **RAID Volumes** and press Enter.
4. Select a RAID volume and press Enter to view the detailed information.
5. Press F10 or Fn+F10 to save the changes and exit.

### Delete a RAID volume

**Attention:** All the existing data stored on the selected drives will be erased after you delete RAID volumes.

To delete a RAID volume:

1. Restart the computer. When the logo screen is displayed, press F1 or Fn+F1.
2. Select **Advanced** → **Intel Virtual RAID on CPU** and press Enter.
3. Select **Intel VROC Managed Volumes** and press Enter.
4. Under **Volume Actions**, select **Delete** and press Enter.
5. When prompted, select **Yes** and press Enter to confirm the deletion of the selected RAID volume.
6. Press F10 or Fn+F10 to save the changes and exit.

---

## Chapter 6. Diagnostics

Use diagnostic solutions to test hardware components and report operating-system-controlled settings that interfere with the correct operation of your computer.

---

### Basic procedure for resolving computer problems

#### Prerequisite

Before you start, read Chapter 1 “Important safety information” on page 1 and print the following instructions.

1. Check that:
    - a. The cables for all connected devices are connected correctly and securely.
    - b. All components have been reassembled correctly.
    - c. All connected devices that require ac power are connected to properly grounded and working electrical outlets.
    - d. All connected devices are enabled in UEFI BIOS.
  2. Use an antivirus program to see if the computer has been infected by a virus. If the program detects a virus, remove the virus.
  3. Go to “Self-help resources” on page 48 and follow the instructions for the type of problem you are experiencing.
  4. Run the diagnostic program.
  5. Recover your operating system. See “Self-help resources” on page 48.
  6. If the problem persists, contact Lenovo.
- 

### UEFI diagnostic program

A UEFI diagnostic program is preinstalled on the computer. It enables you to test memory modules and internal storage devices, view system information, and check and recover bad sectors on internal storage devices.

To run the UEFI diagnostic program, do the following:

1. Turn on the computer. If the computer cannot be turned on, go to “Basic procedure for resolving computer problems” on page 46. If an error code is displayed, go to “Symptom-to-FRU index” on page 33 for error code descriptions and troubleshooting hints.
2. Repeatedly press and release the F10 key when turning on the computer. The main screen of the UEFI diagnostic program is displayed.
3. Follow the instructions on the screen to use the diagnostic program.

The options on the main screen are as follows:

Table 1. Options on the main screen of the UEFI diagnostic program

DIAGNOSTICS	TOOLS
<ul style="list-style-type: none"> <li>• CPU [U]</li> <li>• DISPLAY [D]</li> <li>• MEMORY [E]</li> <li>• MOTHERBOARD [H]</li> <li>• PCI EXPRESS [P]</li> <li>• STORAGE [S]</li> <li>• AUDIO [Z]</li> <li>• OPTICAL [O]</li> <li>• RUN ALL [R]</li> </ul>	<ul style="list-style-type: none"> <li>• SYSTEM INFORMATION [F1]</li> <li>• BAD BLOCK RECOVERY [F3]</li> <li>• SMART INFORMATION [F5]</li> </ul>

**Note:** The options on the main screen might vary, depending on the hardware configuration and the UEFI diagnostic program version preinstalled on the computer.

## Lenovo diagnostic tools

Use diagnostic solutions to test hardware components and report operating-system-controlled settings that interfere with the correct operation of your computer.

When an error message pops up in the Windows notification area, a four-digit error code is displayed on the diagnostic LCD (for selected models) on the front panel, or the diagnostic indicator on the front panel turns on, do one of the following:

- If ThinkStation Diagnostics can be launched properly:
  1. Click the error message or the ThinkStation Diagnostics icon to launch the program.
  2. All events are logged locally in the program. Locate the related event and view the event log to find possible solutions.
  3. Record the four-digit error code displayed on the diagnostic LCD (for selected models) or in ThinkStation Diagnostics, and then decode the error at <https://www.thinkworkstationsoftware.com/?view=codes>.

**Note:** You can download ThinkStation Diagnostics at <https://pcsupport.lenovo.com/lenovodiagnosicsolutions/downloads>.

- If your computer does not function:
  1. Use your smartphone to scan the QR code displayed on the diagnostic LCD to open <https://www.thinkworkstationsoftware.com/?view=codes>.
  2. Decode the error according to the four-digit error code displayed on the diagnostic LCD.

For more information, go to <https://www.thinkworkstationsoftware.com/?view=diags>.

### The Vantage app

The Vantage app is preinstalled on your computer. To diagnose problems with the Vantage app:

1. Type Vantage in the Windows search box and press Enter.
2. Follow the on-screen instructions and run a hardware scan.

If you are unable to isolate and resolve the problem after running the Vantage app, save and print the log files created by the program. You might need the log files when you speak to a Lenovo technical support representative.

---

## Use the Vantage app

The Vantage app is preinstalled on your computer. To diagnose problems with the Vantage app:

1. Type Vantage in the Windows search box and press Enter.
2. Follow the on-screen instructions and run a hardware scan.

If you are unable to isolate and resolve the problem after running the Vantage app, save and print the log files created by the program. You might need the log files when you speak to a Lenovo technical support representative.

---

## Self-help resources

Use the following self-help resources to learn more about the computer and troubleshoot problems.

Resources	How to access?
Troubleshooting and frequently asked questions	<ul style="list-style-type: none"><li>• <a href="https://www.lenovo.com/tips">https://www.lenovo.com/tips</a></li><li>• <a href="https://forums.lenovo.com">https://forums.lenovo.com</a></li></ul>
Accessibility information	<a href="https://www.lenovo.com/accessibility">https://www.lenovo.com/accessibility</a>
Reset or restore Windows	<ul style="list-style-type: none"><li>• Use Lenovo recovery options.<ol style="list-style-type: none"><li>1. Go to <a href="https://support.lenovo.com/HowToCreateLenovoRecovery">https://support.lenovo.com/HowToCreateLenovoRecovery</a>.</li><li>2. Follow the on-screen instructions.</li></ol></li><li>• Use Windows recovery options.<ol style="list-style-type: none"><li>1. Go to <a href="https://pcsupport.lenovo.com">https://pcsupport.lenovo.com</a>.</li><li>2. Detect your computer or manually select your computer model.</li><li>3. Navigate to the troubleshooting menu to diagnose the operating system for recovery instructions.</li></ol></li></ul>

---

Use the Vantage app to:

- Configure device settings.
- Download and install UEFI BIOS, drivers and firmware updates.
- Secure your computer from outside threats.
- Diagnose hardware problems.
- Check the computer warranty status.
- Access *User Guide* and helpful articles.

Type Vantage in the Windows search box.

**Note:** The available features vary depending on the computer model.

---

Resources	How to access?
Product documentation: <ul style="list-style-type: none"> <li>• <i>Safety and Warranty Guide</i></li> <li>• <i>Generic Safety and Compliance Notices</i></li> <li>• <i>Setup Guide</i></li> <li>• <i>This User Guide</i></li> <li>• <i>Regulatory Notice</i></li> </ul>	Go to <a href="https://support.lenovo.com/documentation">https://support.lenovo.com/documentation</a> and search by product.
Lenovo Support Web site with the latest support information of the following: <ul style="list-style-type: none"> <li>• Drivers and software</li> <li>• Diagnostic solutions</li> <li>• Product and service warranty</li> <li>• Product and parts details</li> <li>• Knowledge base and frequently asked questions</li> </ul>	<a href="https://pcsupport.lenovo.com">https://pcsupport.lenovo.com</a>
Windows help information	<ul style="list-style-type: none"> <li>• Type Get Help or Tips in the Windows search box.</li> <li>• Use Windows Search.</li> <li>• Microsoft support Web site: <a href="https://support.microsoft.com">https://support.microsoft.com</a></li> </ul>

---

## Chapter 7. Hardware replacement

This chapter provides instructions on how to remove and install hardware for your computer.

---

### Handling static-sensitive devices

Do not open the static-protective package containing the new part until the defective part has been removed and you are ready to install the new part. Static electricity, although harmless to you, can seriously damage computer components and options.

When you handle options and other computer components, take these precautions to avoid static-electricity damage:

- Limit your movement. Movement can cause static electricity to build up around you.
- Always handle options and other computer components carefully. Handle PCI/PCIe cards, memory modules, system boards, and CPUs by the edges. Never touch any exposed circuitry.
- Prevent others from touching the options and other computer components.
- Touch the static-protective package containing the part to a metal expansion-slot cover or other unpainted metal surface on the computer for at least two seconds. This reduces static electricity from the package and your body before you install or replace a new part.
- When possible, remove the new part from the static-protective package, and install it directly in the computer without setting the part down. When this is not possible, place the static-protective package on a smooth, level surface and place the part on the package.
- Do not place the part on the computer cover or other metal surface.

---

### Service tool kit

Ensure that the following common service tool kit is prepared before you service the computer.

No.	Tool name	Specification	Product scope	Tool type
1	Screwdriver: Phillips Head 0	PH0	All	Common tool
2	Screwdriver: Phillips Head 00	PH00	All	Common tool
3	Screwdriver: Phillips Head 1	PH1	All	Common tool
4	Screwdriver: Phillips Head 01	PH1, shank > 6"	Workstation/DT	Common tool
5	Screwdriver: Phillips Head 02	PH2, shank > 6"	Workstation/DT/SC	Common tool
6	Screwdriver: Torx Head T5	T5	IdeaPad	Common tool

No.	Tool name	Specification	Product scope	Tool type
7	Screwdriver: Torx Head T15	T15, for chassis outside	Workstation	Common tool
8	Screwdriver: Torx Head T20	T20, shank > 6", for heatsink and CPU	Workstation	Common tool
9	Screwdriver: Torx Head T30	T30, shank > 6", for heatsink and CPU	Workstation	Common tool
10	Pry tools 1	N/A	All	Common tool
11	Tweezers (conductive)	Point tip tweezers	All	Common tool
12	Tweezers (isolated)	N/A	All	Common tool
13	Suction cup	N/A	All	Common tool
14	Hexagonal socket (for VGA )	H5 mm or 4.8 mm	ThinkCentre/Tiny	Common tool
15	Hexagonal socket (for Tiny antenna)	H8 mm	ThinkCentre/Tiny	Common tool
16	Adjustable torque screwdriver	0.2 Nm to 4.0 Nm, Threadripper CPU, CAMM, etc	All	Common tool
17	ESD mat	ESD mat	All	Common tool
18	USB flash drives	For Golden Key, Chrome Reloads, AutoPilot, etc	All	Common tool
19	USB-C to USB-A converter / HDMI to HDMI cable (optional)	For USB-C only systems / For systems with HDMI connectors	All	Common tool
20	SIM card pin	For systems with 4G/5G WWAN SIM card	All	Common tool
21	Hexagonal socket	H10 mm	ThinkEdge	Common tool
22	Screwdriver: Slotted Head	SL3.0 mm	ThinkEdge	Common tool
23	SSD/WWAN/IC thermal pad	Available in different thicknesses, most commonly 0.5 mm	All	Consumable

No.	Tool name	Specification	Product scope	Tool type
24	Silicone grease for CPU/GPU or heatsink repairing	Recommended thermal conductivity > 6W/mK, such as TC5888/TC5550/PTM7950/PTM7958. Follow HMM-specific guidance.	All	Consumable
25	Thermal gel / Thermal putty / Thermal gum	XPG-0001/TC7006	All	Consumable
26	Polyamide tape	N/A	All	Consumable
27	Mylar tape	N/A	All	Consumable
28	Eraser	N/A	All	Consumable
29	Electrical tape	N/A	All	Consumable
30	Double sided tape	N/A	All	Consumable
31	Conductive tape	N/A	All	Consumable
32	Cleaning pads/wipes	N/A	All	Consumable
33	Heat gun	N/A	All	Special Tool (Depot only)
34	Brown brush	25 mm to 35 mm wide	All	Special tool
35	Contact cleaner spray	WD-40 contact cleaner for battery connector	ThinkPad X1 Carbon	Special tool
36	Hexagonal socket	17 mm	Yoga AIO 7 27ACH6 / Yoga AIO 7 27ARH6	Special tool

**Note:** The silicone grease can be applied to the surfaces of the CPU and heat sink to eliminate air gaps. For parts with silicone grease applied, it is suggested that you apply new grease during the installation.

## Expand your computer

You can enhance your computer capacity and performance by adding various devices according to the following rules:

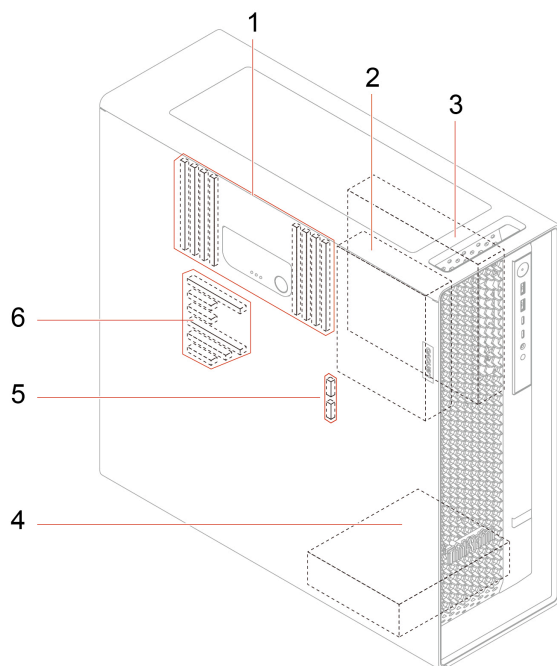

Item	Description
1. Memory slots	Depending on your computer model, you can install up to eight memory modules in the memory slots.
2. Optional storage drive bay	You can install a 3.5-inch HDD in the optional storage drive bay. <b>Note:</b> If you want to install a storage drive into the optional-storage-drive bay, contact the Lenovo Customer Support Center for help.
3. Flex bay	In flex bay, you can install one of the following devices: <ul style="list-style-type: none"> <li>• One 15-in-1 media card reader</li> <li>• One flex module</li> </ul> In the flex module, you can install a 2280 Gen 4 M.2 SSD (hot-swappable).
4. Storage drive bay	You can install one or two 3.5-inch HDDs in the storage drive bay.
5. Onboard M.2 SSD slots	This computer supports the following types of M.2 SSD: <ul style="list-style-type: none"> <li>• 2280 Gen 4 M.2 SSD</li> <li>• 2280 Gen 5 M.2 SSD</li> </ul> You can install one or two M.2 SSDs in onboard M.2 SSD slots. For better performance, it's recommended that you install M.2 SSDs of the same generation.
6. PCI-Express slot	You can install compatible PCIe cards (up to six) in the PCIe card slots.

\* for selected models

### Related topics

- “Memory module” on page 69
- “Optional HDD and its cage” on page 77
- “Flex module” on page 79
- “Flex bay cage” on page 78

- “15-in-1 media card reader” on page 78
- “M.2 SSD in flex module” on page 80
- “Onboard M.2 SSD and its heatsink kit” on page 82
- “PCIe card and extender” on page 97

## System board illustration

**Note:** The system board might look slightly different from the illustration.

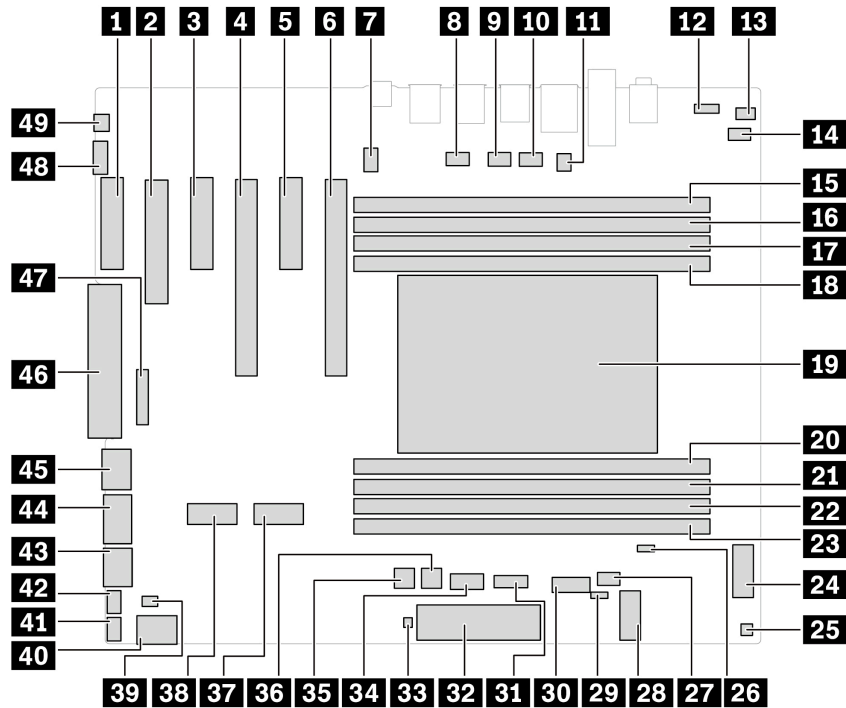

Figure 1. System board illustration

Item	Description	Item	Description
<b>1</b>	PCIe x4 card slot	<b>2</b>	PCIe x8 card slot
<b>3</b>	PCIe x4 card slot	<b>4</b>	PCIe x16 card slot
<b>5</b>	PCIe x4 card slot	<b>6</b>	PCIe x16 card slot
<b>7</b>	CPU fan connector	<b>8</b>	Rear fan connector
<b>9</b>	Memory duct fan connector 1	<b>10</b>	Memory duct fan connector 2
<b>11</b>	Serial port connector	<b>12</b>	VROC connector
<b>13</b>	Speaker connector	<b>14</b>	Cover presence switch connector
<b>15</b>	Memory slot 1	<b>16</b>	Memory slot 2
<b>17</b>	Memory slot 3	<b>18</b>	Memory slot 4
<b>19</b>	CPU socket	<b>20</b>	Memory slot 5

Item	Description	Item	Description
<b>21</b>	Memory slot 6	<b>22</b>	Memory slot 7
<b>23</b>	Memory slot 8	<b>24</b>	Flex bay connector
<b>25</b>	Thermal sensor connector	<b>26</b>	Clear CMOS connector
<b>27</b>	Flex bay fan connector	<b>28</b>	Wi-Fi card connector
<b>29</b>	Recovery jumper	<b>30</b>	SATA 3 connector
<b>31</b>	ALT_TPM slot	<b>32</b>	Front panel connector
<b>33</b>	Drive-act connector for RAID card	<b>34</b>	15-in-1 media card reader connector
<b>35</b>	HDD power connector 1	<b>36</b>	HDD power connector 2
<b>37</b>	M.2 card slot 1	<b>38</b>	M.2 card slot 2
<b>39</b>	Think LED logo connector	<b>40</b>	SATA 2 connector
<b>41</b>	Front fan connector	<b>42</b>	HDD Fan connector
<b>43</b>	SATA 1 connector	<b>44</b>	750-watt PSU power connector
<b>45</b>	CPU power connector	<b>46</b>	Auxiliary power connector
<b>47</b>	BMC connector	<b>48</b>	Thunderbolt cable connector
<b>49</b>	Thunderbolt power connector		

## Major FRUs and CRUs

Your computer contains the following types of CRUs and FRUs:

- **Self-service CRUs:** Refer to parts that can be replaced easily by customer themselves or by trained service technicians at an additional cost.
- **Optional-service CRUs:** Refer to parts that can be replaced by customers with a greater skill level. Trained service technicians can also provide service to replace the parts under the type of warranty designated for the customer's machine.
- **FRUs:** Refer to parts that are more complicated to replace and it is recommended that these should be replaced by trained service technicians. If customers elect to replace the FRUs by themselves, we recommend that you ensure the correct instructions provided by Lenovo are carefully followed.

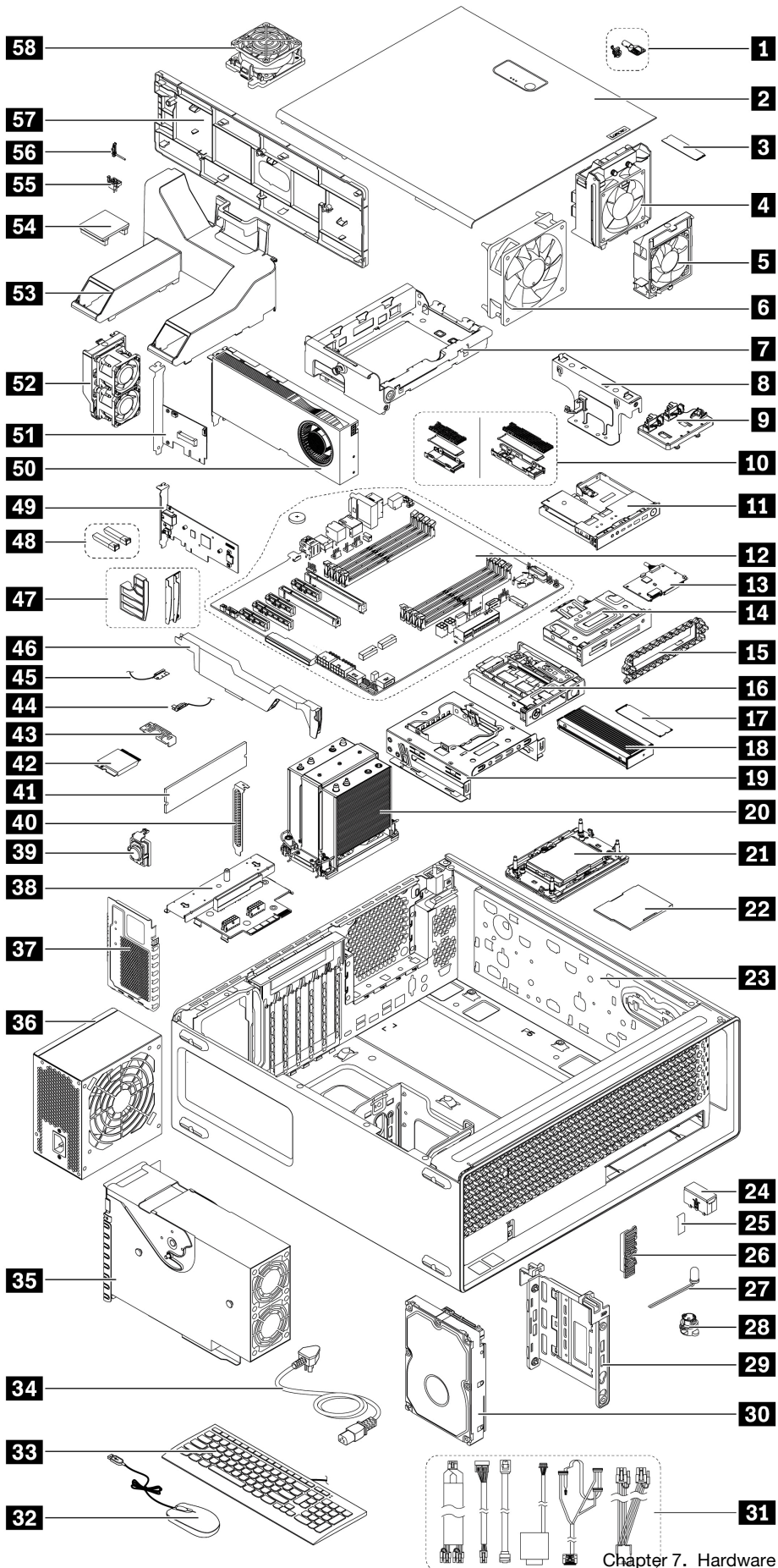

Number	Description	Self-service CRU	Optional-service CRU
<b>1</b>	Lock kits for side cover*	Yes	No
<b>2</b>	Side cover	Yes	No
<b>3</b>	2280 Gen 4 or Gen 5 M.2 SSD*	Yes	No
<b>4</b>	Front fan	Yes	No
<b>5</b>	HDD fan*	Yes	No
<b>6</b>	Rear fan	Yes	No
<b>7</b>	Optional HDD cage*	Yes	No
<b>8</b>	Optional HDD cage bracket*	Yes	No
<b>9</b>	M.2 SSD holder	Yes	No
<b>10</b>	2280 Gen 4 or Gen 5 M.2 SSD heatsink kit	Yes	No
<b>11</b>	Front panel I/O assembly	No	Yes
<b>12</b>	System board and coin-cell battery assembly	No	No
<b>13</b>	PCBA of 15-in-1 media card reader*	No	Yes
<b>14</b>	15-in-1 media card reader bezel kit*	No	Yes
<b>15</b>	Flex bay dummy cover*	Yes	No
<b>16</b>	Flex module*	Yes	No
<b>17</b>	M.2 SSD in M.2 SSD box*	Yes	No
<b>18</b>	M.2 SSD box in flex module*	Yes	No
<b>19</b>	Flex bay cage*	Yes	No
<b>20</b>	CPU heat sink	No	No
<b>21</b>	CPU Carrier	No	No
<b>22</b>	CPU	No	No
<b>23</b>	Chassis	No	No
<b>24</b>	NVLINK retainer*	Yes	No
<b>25</b>	ID badge*	Yes	No
<b>26</b>	ThinkStation logo badge	Yes	No
<b>27</b>	Think LED cable	Yes	No
<b>28</b>	Think LED holder	Yes	No
<b>29</b>	HDD bracket*	Yes	No
<b>30</b>	HDD*	Yes	No
<b>31</b>	Power cable or SATA cable	No	No
<b>32</b>	Mouse*	Yes	No
<b>33</b>	Keyboard*	Yes	No
<b>34</b>	Power cord	Yes	No
<b>35</b>	1000-Watt power supply assembly*	Yes	No
<b>36</b>	750-Watt power supply assembly*	Yes	No

Number	Description	Self-service CRU	Optional-service CRU
<b>37</b>	Power supply unit cover*	Yes	No
<b>38</b>	Power distribution board and bracket	Yes	No
<b>39</b>	Internal Speaker	No	Yes
<b>40</b>	PCIe bracket	Yes	No
<b>41</b>	Memory module	Yes	No
<b>42</b>	Wi-Fi Card*	No	No
<b>43</b>	Wi-Fi card Cover*	No	No
<b>44</b>	Front wifi antenna cable*	No	No
<b>45</b>	Rear wifi antenna cable*	No	No
<b>46</b>	Super capacitor module*	Yes	No
<b>47</b>	Customized PCIe extender*	Yes	No
<b>48</b>	Fiber modules of some Ethernet adapter cards*	No	Yes
<b>49</b>	BMC Card*	No	No
<b>50</b>	Full-length PCIe card*	No	Yes
<b>51</b>	Half-length PCIe card*	No	Yes
<b>52</b>	Memory fan	Yes	No
<b>53</b>	Memory fan duct	Yes	No
<b>54</b>	NVLINK Bridge*	No	Yes
<b>55</b>	Cover presence switch	No	No
<b>56</b>	Ambient temp sensor	No	No
<b>57</b>	Top cover	Yes	No
<b>58</b>	Flex bay fan*	Yes	No

For detailed FRU and CRU information, such as the FRU part numbers and supported computer models, go to:

<http://www.lenovo.com/serviceparts-lookup>

---

## External options

You can connect external options to your computer, such as external speakers, a printer, or a scanner. For some external options, you must install additional software in addition to making the physical connection. When installing an external option, see Chapter 3 “Product overview” on page 29 to identify the required connector. Then, use the instructions that come with the option to help you make the connection and install any required software or device drivers.

---

## ID badge

### Prerequisite

Before you start, read [Generic Safety and Compliance Notices](#), and print the following instructions.

### Removal steps

Remove the ID badge.

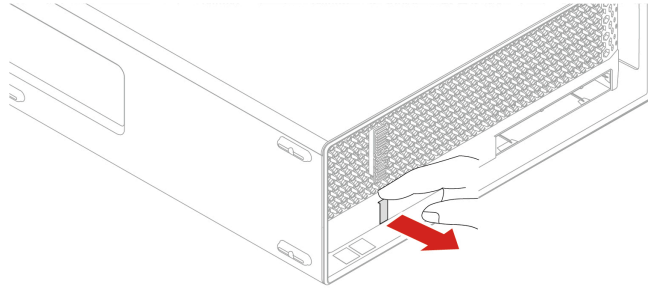

---

## ThinkStation logo badge

### Prerequisite

Before you start, read [Generic Safety and Compliance Notices](#), and print the following instructions.

### Removal steps

Remove the ThinkStation logo badge.

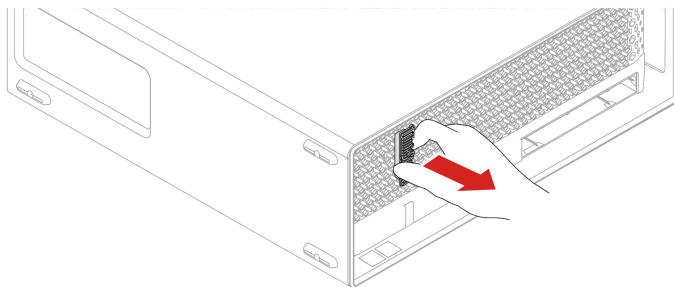

---

## Side cover

### Prerequisite

Before you start, read [Generic Safety and Compliance Notices](#), and print the following instructions.



Before you open the computer cover, turn off the computer and wait several minutes until the computer is cool.

For access, do the following:

1. Turn off the computer and remove all connected devices and cables.
2. Unlock any locking device that secures the computer cover.
3. Place a soft, clean towel or cloth on the desk or surface. Hold the sides of your computer and gently lay it down so that the screen is against the surface and the computer cover is facing up.
4. Press the handle of the side cover so that the handle is lifted.

### Removal steps

Remove the side cover.

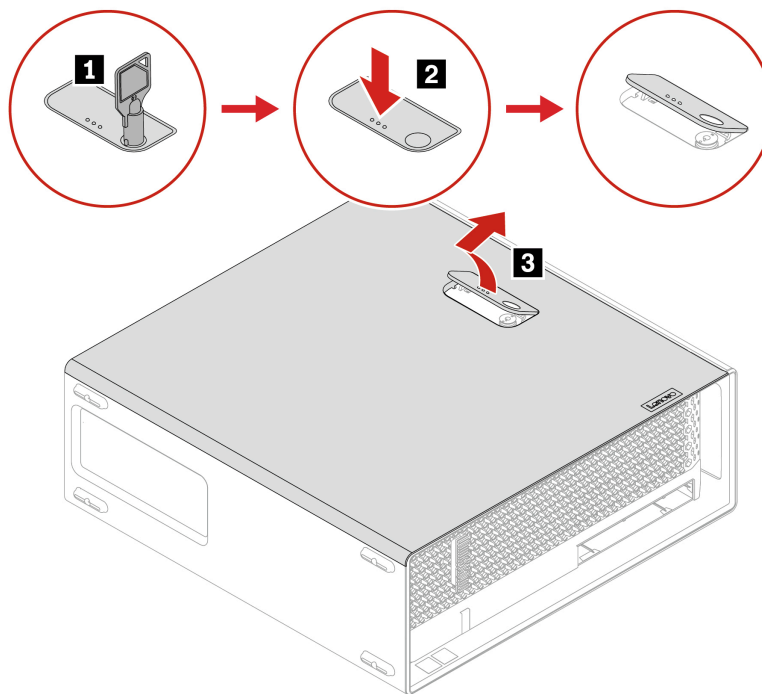

### Installation steps

Install the side cover.

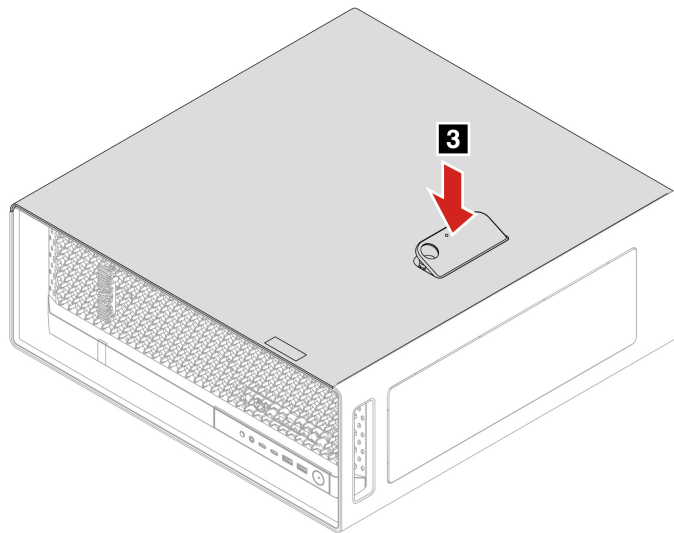
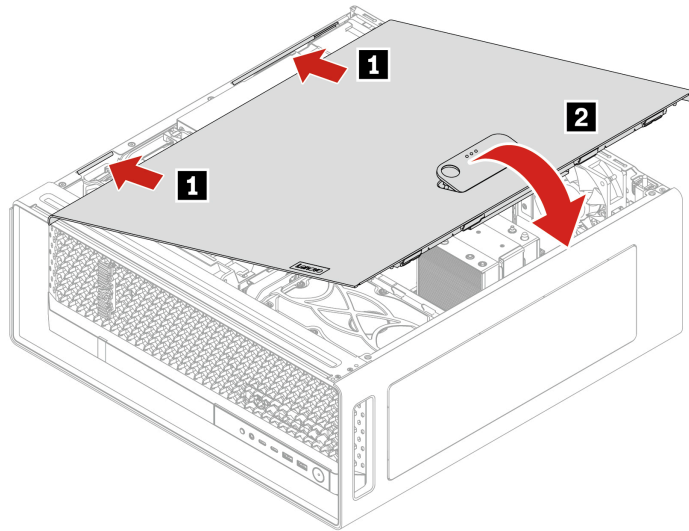

**Notes:**

- If a locking device is available, use it to lock the computer after installing the computer cover.
- Depending on your computer model, some of the hardware parts in the replacing section might not be available.

---

## Top cover

### Prerequisite

Before you start, read [Generic Safety and Compliance Notices](#), and print the following instructions.



Before you open the computer cover, turn off the computer and wait several minutes until the computer is cool.

For access, remove the “Side cover” on page 59.

### Removal steps

Remove the top cover.

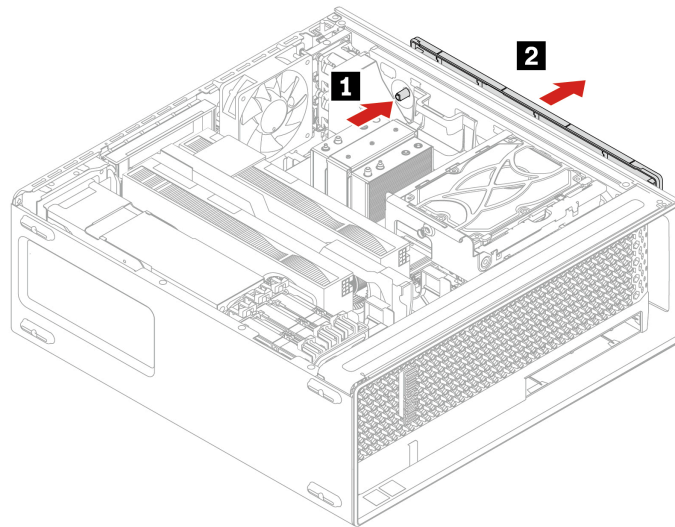

---

## Front panel I/O assembly

### Prerequisite

Before you start, read [Generic Safety and Compliance Notices](#), and print the following instructions.

For access, do the following:

1. Remove the “Side cover” on page 59.
2. Remove the “Optional HDD and its cage” on page 77.
3. Remove the “Flex bay fan” on page 74.

### Removal steps

Remove the front panel I/O assembly.

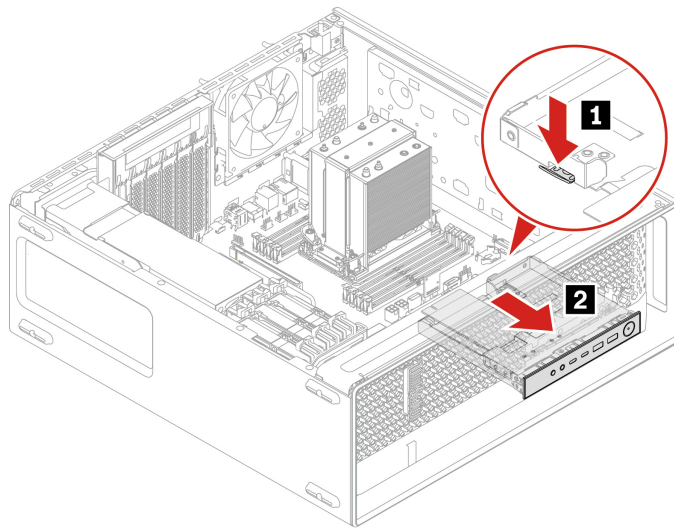

### Installation steps

Install the front panel I/O assembly.

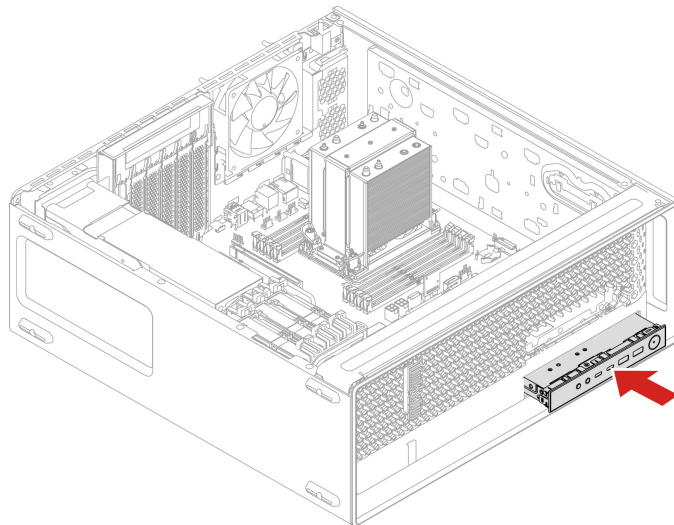

---

## Internal speaker

### Prerequisite

Before you start, read [Generic Safety and Compliance Notices](#), and print the following instructions.

For access, do the following:

1. Remove the “Side cover” on page 59.
2. Remove the “Rear fan” on page 72.

## Removal steps

Remove the internal speaker.

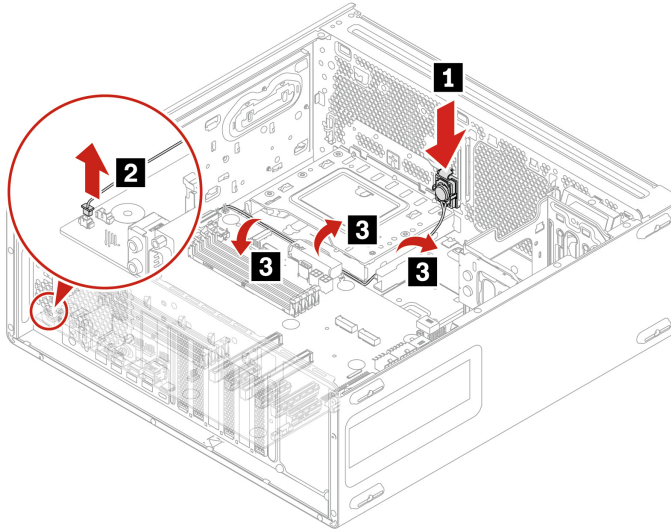

---

## Think LED cable

### Prerequisite

Before you start, read [Generic Safety and Compliance Notices](#), and print the following instructions.

For access, do the following:

1. Remove the “Side cover” on page 59.
2. Remove the “Front fan” on page 71.

### Removal steps

Remove the Think LED cable.

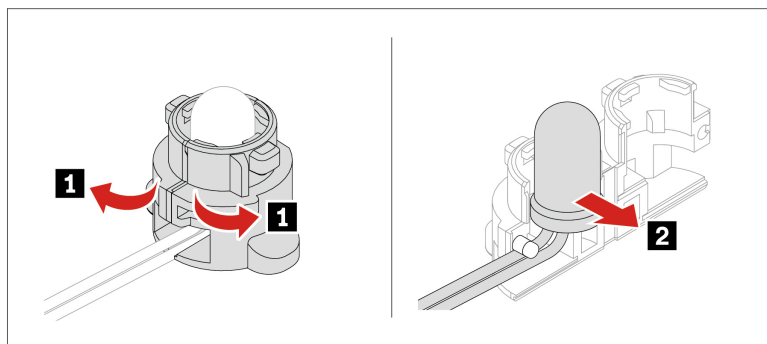
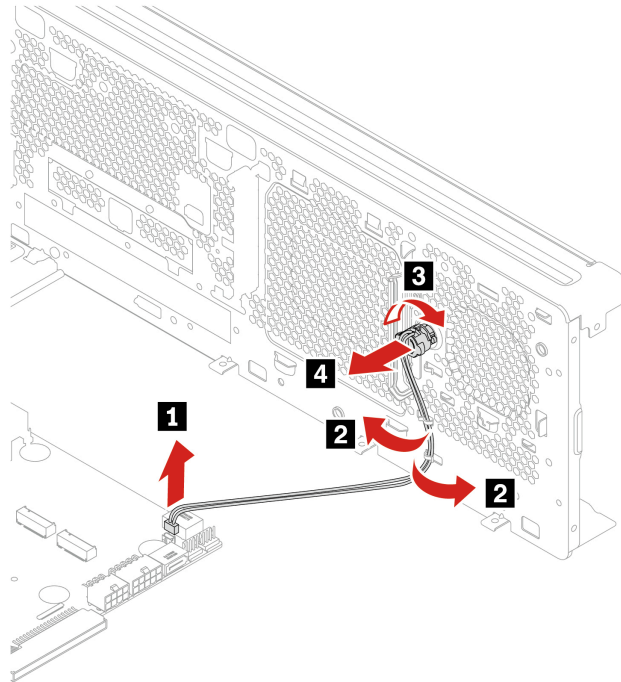

## Power supply assembly

### Prerequisite

Before you start, read [Generic Safety and Compliance Notices](#), and print the following instructions.

Although there are no moving parts in the computer after the power cord has been disconnected, the following warnings are required for your safety.



Keep fingers and other parts of your body away from hazardous, moving parts. If you suffer an injury, seek medical care immediately. Never remove the cover on a power supply or any part that has the following label attached.



Hazardous voltage, current, and energy levels are present inside any component that has this label attached. There are no serviceable parts inside these components. If you suspect a problem with one of these parts, contact a service technician.

For access, remove the “Side cover” on page 59.

### Removal steps

- For 1000-watt power supply assembly:

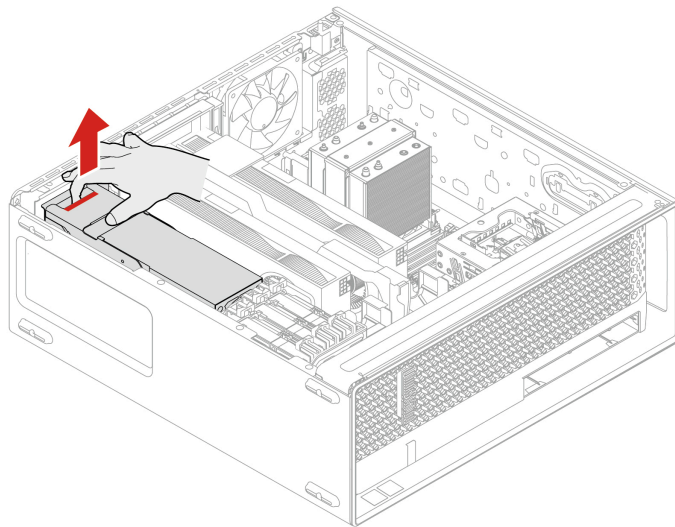

- For 750-Watt power supply assembly:

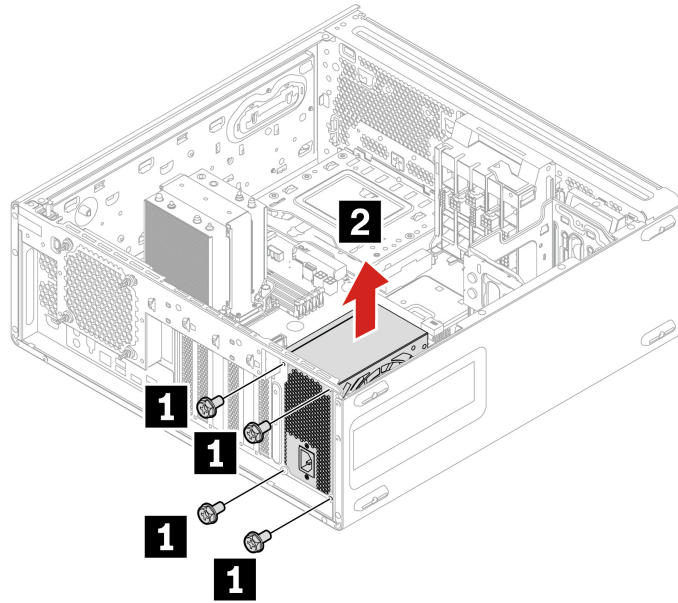

Screw (quantity)	Color	Torque
M3 x 5 mm, Nickel coated (4)	Black	5.0 ± 0.5 lb/in

## Power supply unit cover

### Prerequisite

Before you start, read [Generic Safety and Compliance Notices](#), and print the following instructions.



Before you open the computer cover, turn off the computer and wait several minutes until the computer is cool.

For access, do the following:

1. Remove the “Side cover” on page 59.
2. Remove the “Power supply assembly” on page 65.

### Removal steps

Remove the power supply unit cover.

**Note:** Depending on your computer model, the power supply unit cover only comes with 1000-watt power supply assembly.

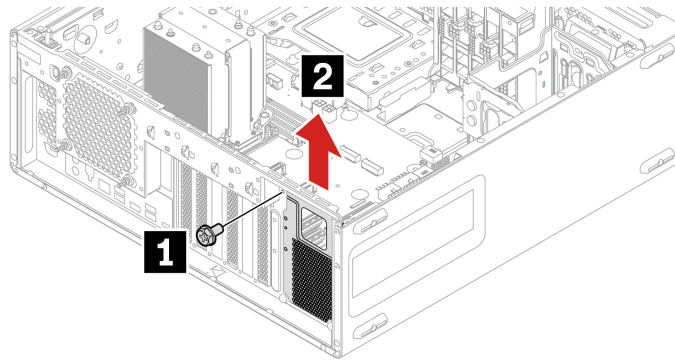

---

Screw (quantity)	Color	Torque
M3 x 5 mm, Nickel coated (1)	Black	5.0 ± 0.5 lb/in

---

## Power distribution board and bracket

### Prerequisite

Before you start, read [Generic Safety and Compliance Notices](#), and print the following instructions.

For access, do the following:

1. Remove the “Side cover” on page 59.
2. Remove the “Power supply assembly” on page 65.

### Removal steps

Remove the power distribution board and bracket.

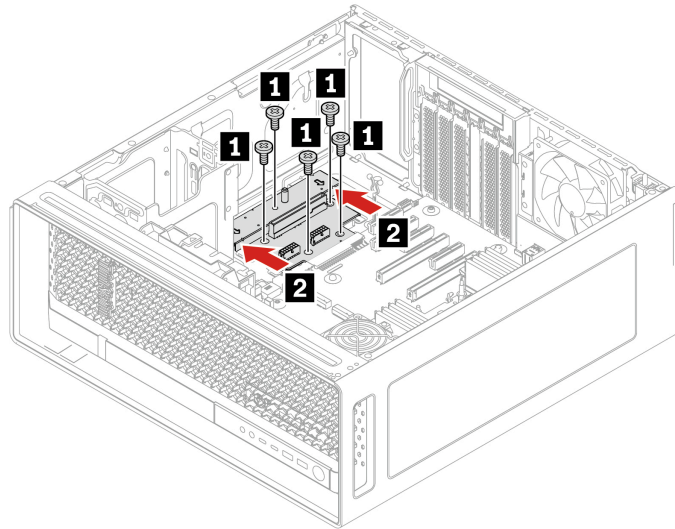

---

Screw (quantity)	Color	Torque
M3 x 5 mm, Nickel coated (4)	Black	5.0 ± 0.5 lb/in

---

## Memory module

### Prerequisite

Before you start, read *Generic Safety and Compliance Notices*, and print the following instructions.

### Notes:

- To remove or install the memory module, wait at least 20 seconds after disconnecting power cords from the system. It allows the system to be completely discharged of electricity.
- Ensure that you follow the installation order for memory modules shown in the following illustration.

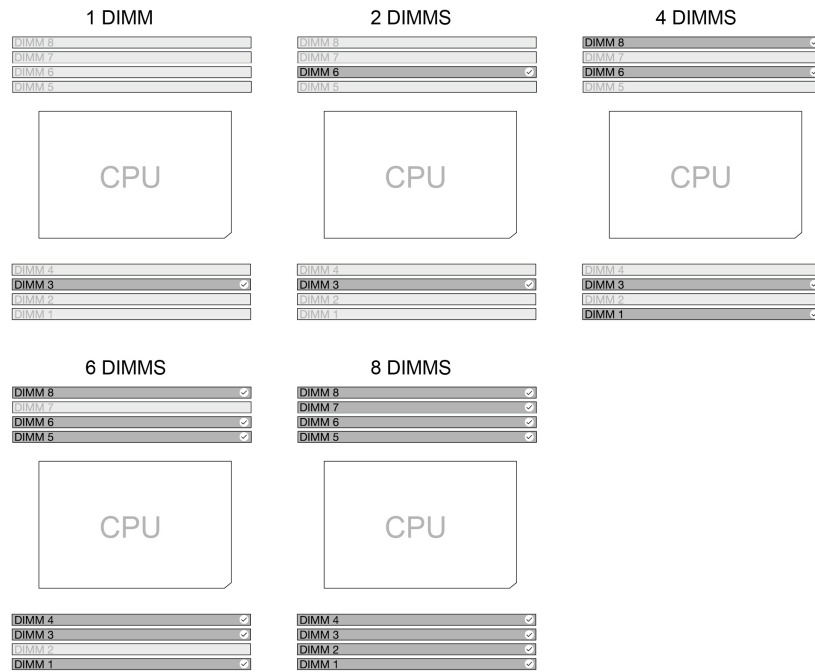

Figure 2. Memory module order

For access, do the following:

1. Remove the “Side cover” on page 59.
2. Remove the “Memory fan duct” on page 72.

### Removal steps

Remove the memory module.

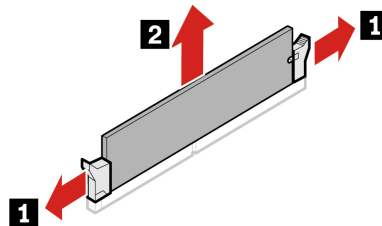

### Installation steps

Install the memory module.

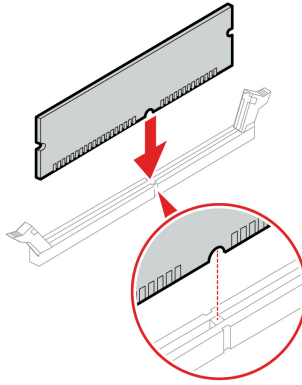

---

## Fans

By reading this section, you will learn to replace the fans in your computer.

### Front fan

#### Prerequisite

Before you start, read [Generic Safety and Compliance Notices](#), and print the following instructions.

For access, do the following:

1. Remove the “Side cover” on page 59.
2. Remove the “Super capacitor module” on page 95.
3. Remove the “PCIe card and extender” on page 97.

#### Removal steps

Remove the front fan.

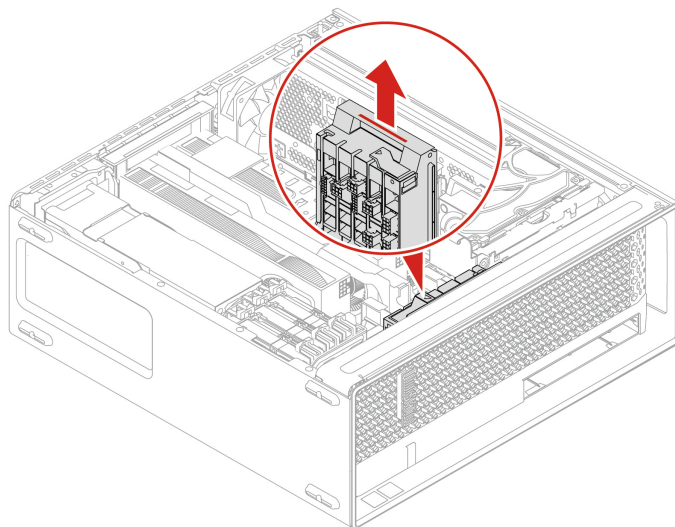

## Rear fan

### Prerequisite

Before you start, read [Generic Safety and Compliance Notices](#), and print the following instructions.

For access, remove the “Side cover” on page 59.

### Removal steps

Remove the rear fan.

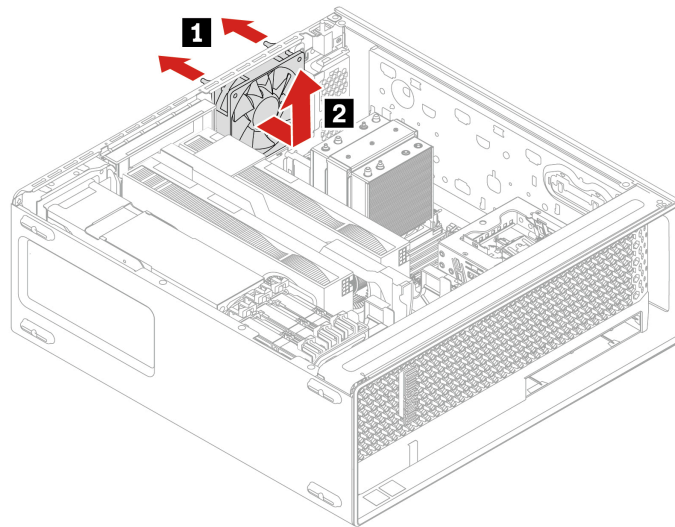

## Memory fan duct

### Prerequisite

Before you start, read [Generic Safety and Compliance Notices](#), and print the following instructions.



Before you touch the memory fan duct, wait several minutes until the component is cool.

For access, remove the “Side cover” on page 59.

### Removal steps

Remove the memory fan duct.

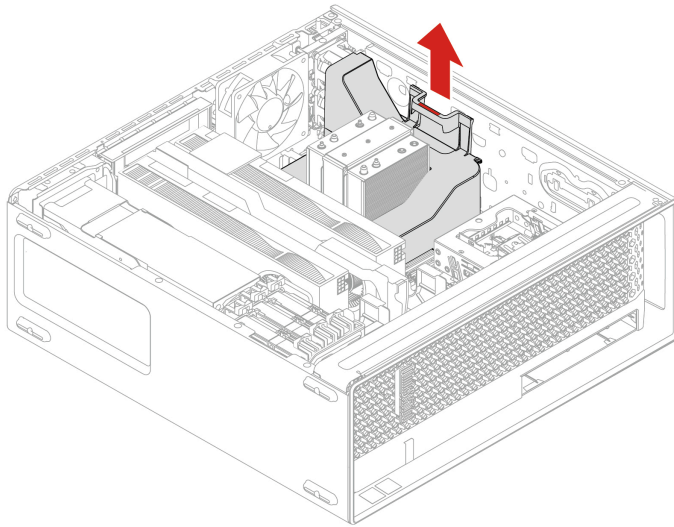

## Memory fan

### Prerequisite

Before you start, read [Generic Safety and Compliance Notices](#), and print the following instructions.

For access, do the following:

1. Remove the “Side cover” on page 59.
2. Remove the “Memory fan duct” on page 72.

### Removal steps

Remove the memory fan.

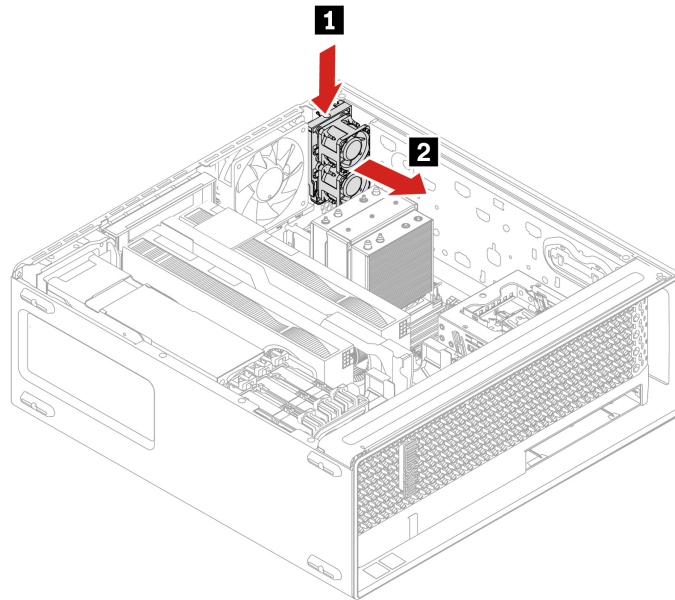

## HDD fan

### Prerequisite

Before you start, read [Generic Safety and Compliance Notices](#), and print the following instructions.

For access, remove the “Side cover” on page 59.

### Removal steps

Remove the HDD fan.

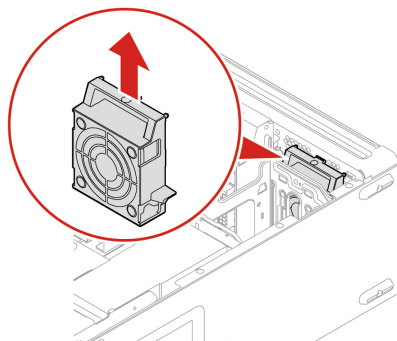

## Flex bay fan

### Prerequisite

Before you start, read [Generic Safety and Compliance Notices](#), and print the following instructions.

For access, do the following:

1. Remove any media from the drives and turn off all connected devices and the computer.
2. Disconnect all power cords from electrical outlets and disconnect all cables from the computer.
3. Remove the “Side cover” on page 59.
4. Remove the “Optional HDD and its cage” on page 77.

### Removal steps

Remove the flex bay fan.

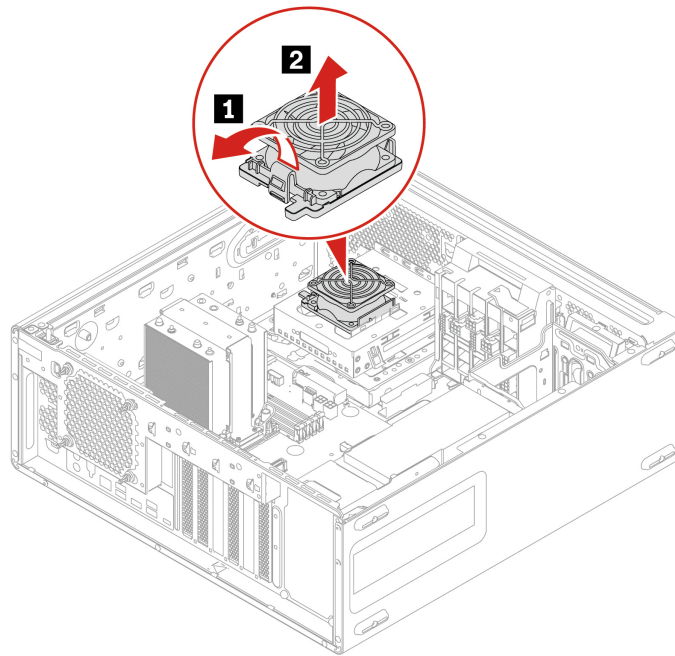

---

## Storage drives

By reading this section, you will learn to replace storage drives in your computer.

### HDD and its bracket

#### Prerequisite

Before you start, read *Generic Safety and Compliance Notices*, and print the following instructions.

**Attention:** The internal storage drive is sensitive. Inappropriate handling might cause damage and permanent loss of data. When handling the internal storage drive, observe the following guidelines:

- Replace the internal storage drive only for repair. The internal storage drive is not designed for frequent changes or replacement.
- Before replacing the internal storage drive, make a backup copy of all the data that you want to keep.
- Do not touch the contact edge of the internal storage drive. Otherwise, the internal storage drive might get damaged.

- Do not apply pressure to the internal storage drive.
- Do not make the internal storage drive subject to physical shocks or vibration. Put the internal storage drive on a soft material, such as cloth, to absorb physical shocks.

For access, remove the “Side cover” on page 59.

### Removal steps

Remove the HDD and its bracket.

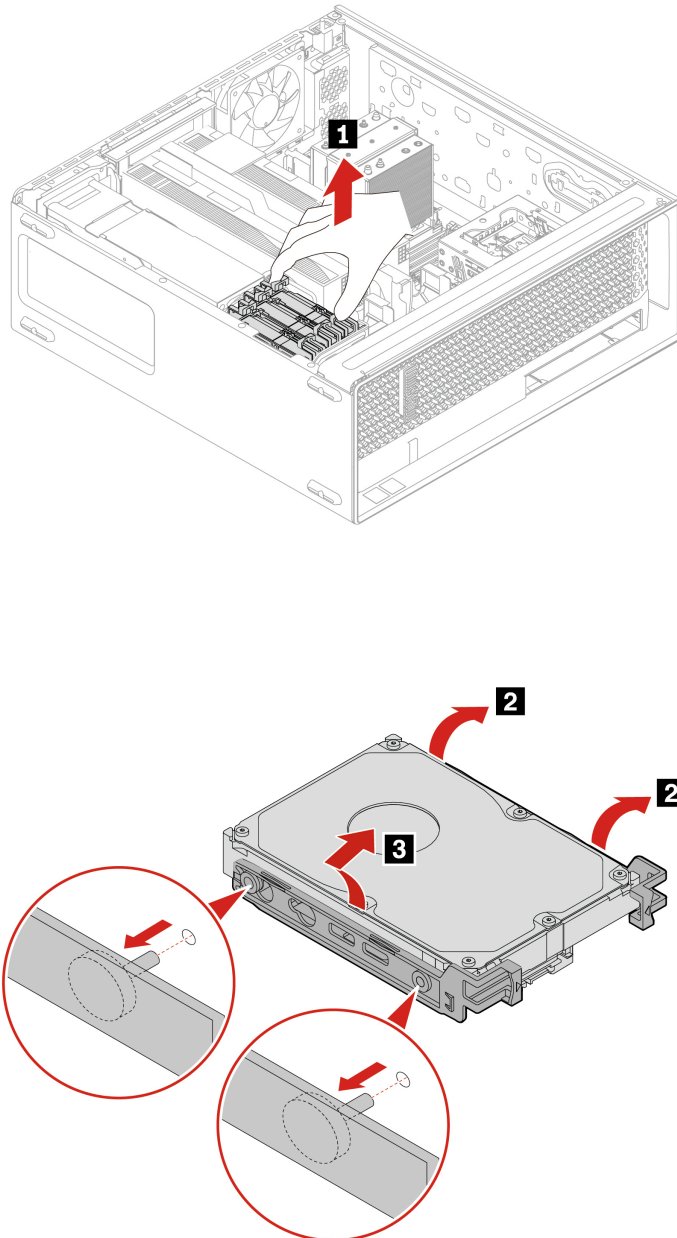

## Optional HDD and its cage

### Prerequisite

Before you start, read [Generic Safety and Compliance Notices](#), and print the following instructions.

For access, do the following:

1. Remove any media from the drives and turn off all connected devices and the computer.
2. Disconnect all power cords from electrical outlets and disconnect all cables from the computer.
3. Remove the “Side cover” on page 59.

### Removal steps

Remove the optional HDD.

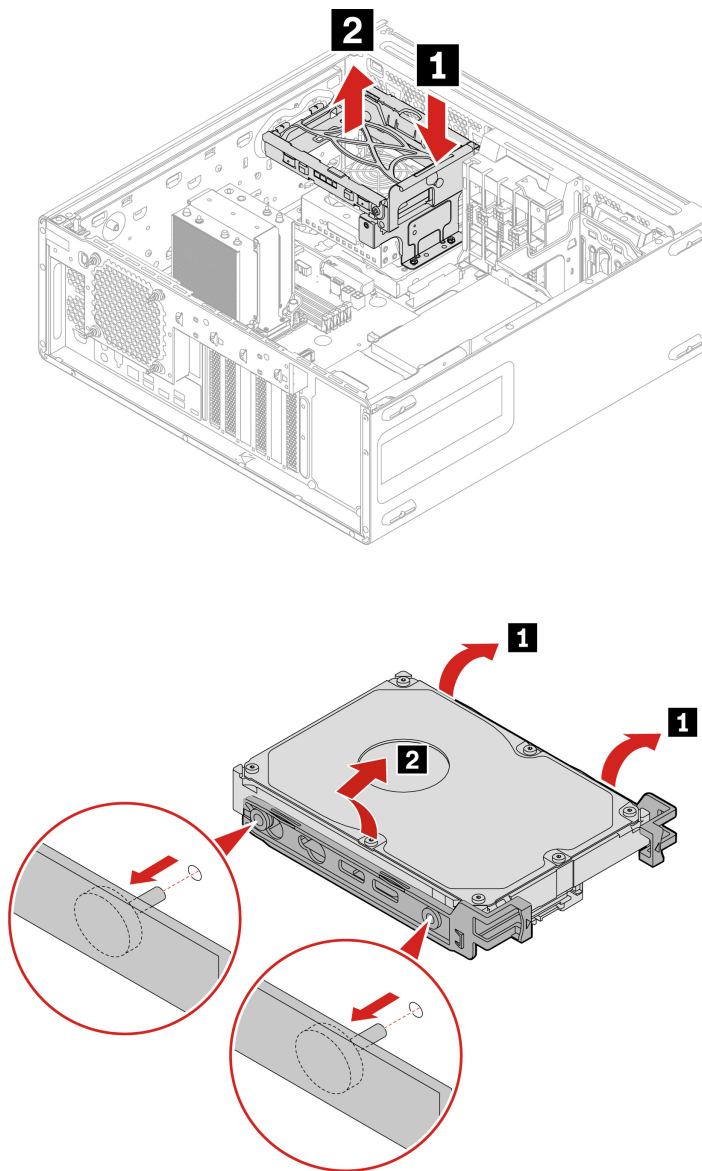

## Flex bay cage

### Prerequisite

Before you start, read [Generic Safety and Compliance Notices](#), and print the following instructions.

For access, do the following:

1. Remove any media from the drives and turn off all connected devices and the computer.
2. Disconnect all power cords from electrical outlets and disconnect all cables from the computer.
3. Remove the “Side cover” on page 59.
4. Remove the “Optional HDD and its cage” on page 77.
5. Remove the “Flex bay fan” on page 74.
6. Remove the “Flex module” on page 79.
7. Remove the “15-in-1 media card reader” on page 78, if any.

### Removal steps

Remove the flex bay cage.

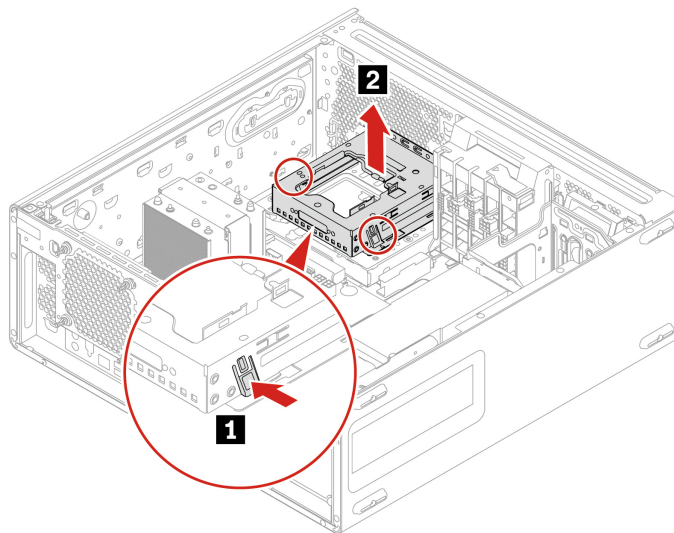

## 15-in-1 media card reader

### Prerequisite

Before you start, read [Generic Safety and Compliance Notices](#), and print the following instructions.

For access, do the following:

1. Remove any media from the drives and turn off all connected devices and the computer.
2. Disconnect all power cords from electrical outlets and disconnect all cables from the computer.
3. Remove the “Side cover” on page 59.
4. Remove the “Optional HDD and its cage” on page 77.
5. Remove the “Flex bay fan” on page 74.

## Removal steps

Remove the 15-in-1 media card reader.

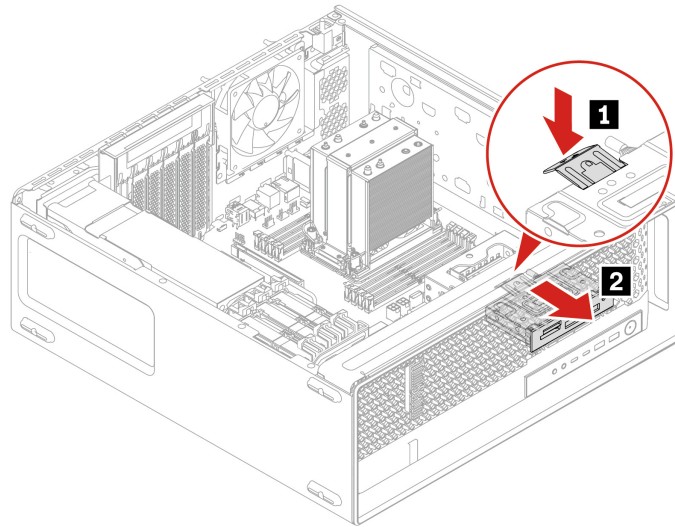

## Installation steps

Install the 15-in-1 media card reader.

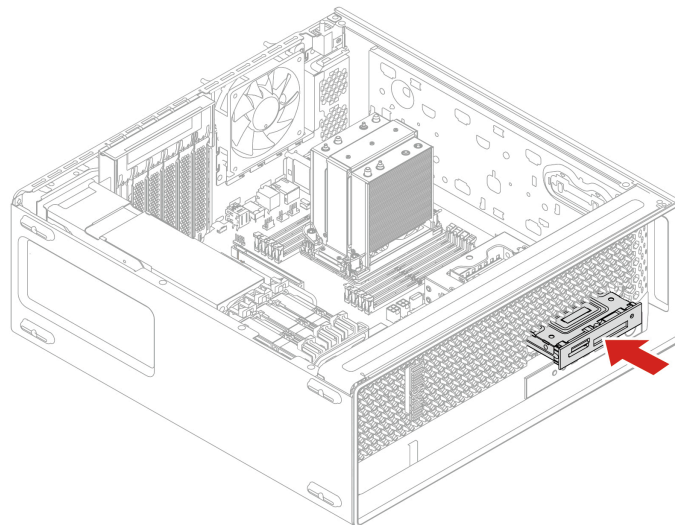

## Flex module

### Prerequisite

Before you start, read [Generic Safety and Compliance Notices](#), and print the following instructions.

For access, do the following:

1. Remove any media from the drives and turn off all connected devices and the computer.
2. Disconnect all power cords from electrical outlets and disconnect all cables from the computer.

3. Remove the “Side cover” on page 59.
4. Remove the “Optional HDD and its cage” on page 77.
5. Remove the “Flex bay fan” on page 74.

### Removal steps

Remove the flex module.

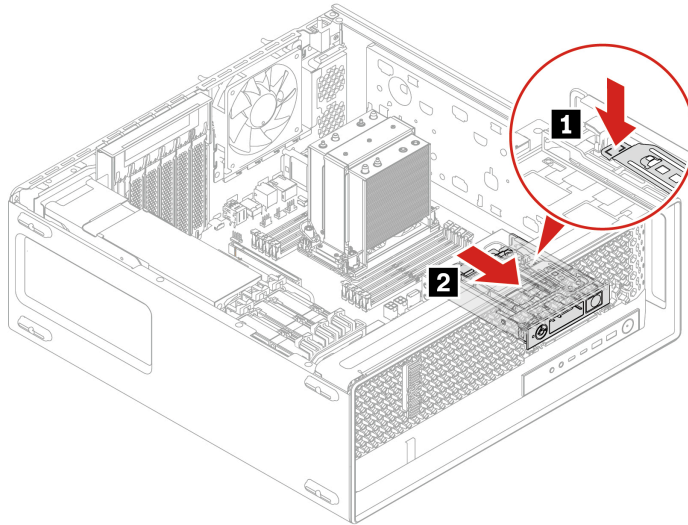

### Installation steps

Install the flex module.

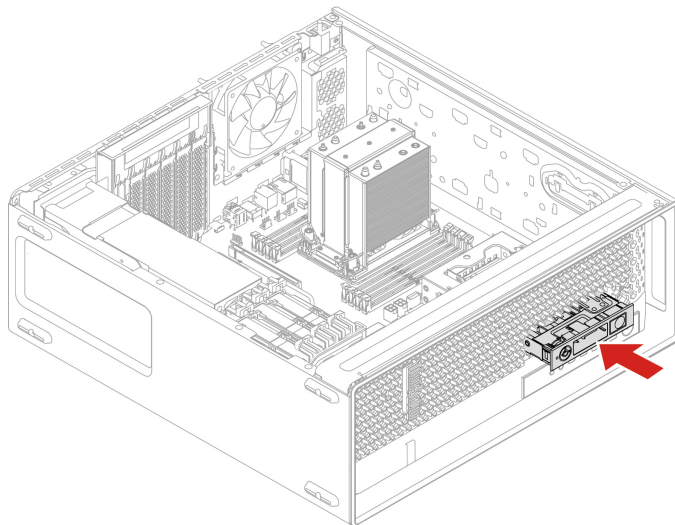

## M.2 SSD in flex module

You can install or replace a M.2 SSD in the flex module. The flex module supports hot-swappable, which means that you can install or replace the M.2 SSD without even turning off your computer.

To enable hot-swappable function, you need to enable Intel VMD technology on MCIO slot first. Follow below steps:

1. Restart the computer. When the logo screen is displayed, press F1 or Fn+F1 to enter the BIOS menu.
2. Click **Devices** → **Storage Setup** → **Intel(R) VMD Technology**.
3. Select **VMD** under **MCIO slot** configuration.

#### Notes:

- The storage drive in the flex module is hot-swappable only when the operating system of your computer does not reside on the storage drive installed in the flex module. If the requirements is not met, do not remove or install the storage drive when the computer is turned on. Otherwise, data on the storage drive might get damaged.
- Lock the flex module to prevent the unexpected removal. The keys are attached to the rear of the machine. For security, store the keys in a secure place when you are not using them.

#### Prerequisite

Before you start, read [Generic Safety and Compliance Notices](#), and print the following instructions.

**Attention:** The internal storage drive is sensitive. Inappropriate handling might cause damage and permanent loss of data. When handling the internal storage drive, observe the following guidelines:

- Replace the internal storage drive only for repair. The internal storage drive is not designed for frequent changes or replacement.
- Before replacing the internal storage drive, make a backup copy of all the data that you want to keep.
- Do not touch the contact edge of the internal storage drive. Otherwise, the internal storage drive might get damaged.
- Do not apply pressure to the internal storage drive.
- Do not make the internal storage drive subject to physical shocks or vibration. Put the internal storage drive on a soft material, such as cloth, to absorb physical shocks.

#### Removal steps

Remove the M.2 SSD.

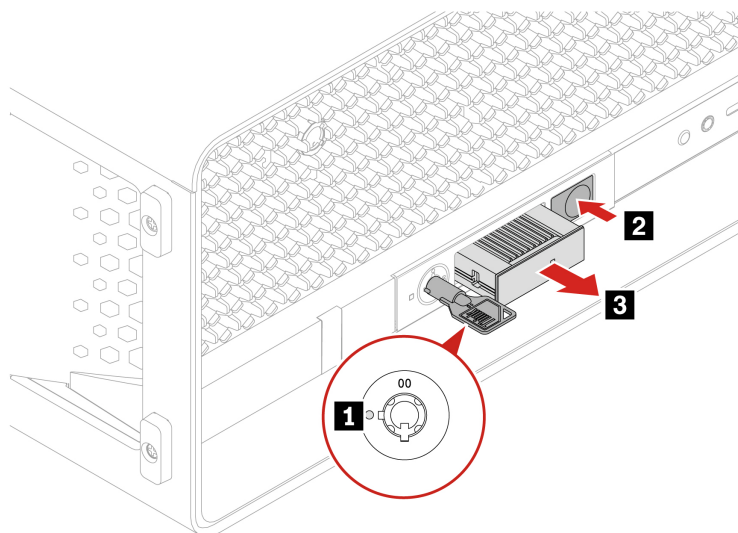

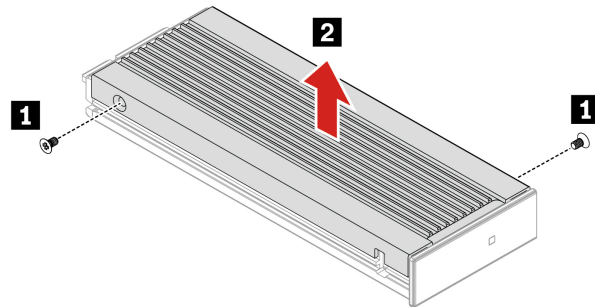

Screw (quantity)	Color	Torque
M2 x 3.6 mm, Zn coated (2)	Blue	1.5 ± 0.2 lb/in

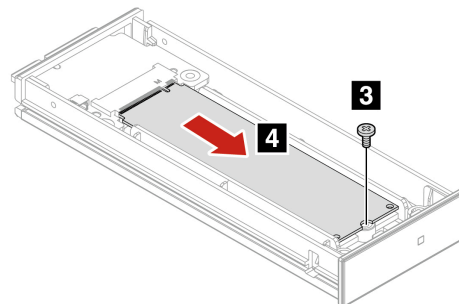

Screw (quantity)	Color	Torque
M2 x 4.5 mm, Zn coated (1)	Black	1.5 ± 0.2 lb/in

## Onboard M.2 SSD and its heatsink kit

### Prerequisite

Before you start, read *Generic Safety and Compliance Notices*, and print the following instructions.



The heat sink of M.2 SSD might be very hot. Before you open the computer cover, turn off the computer and wait several minutes until the component is cool.

**Attention:** The internal storage drive is sensitive. Inappropriate handling might cause damage and permanent loss of data. When handling the internal storage drive, observe the following guidelines:

- Replace the internal storage drive only for repair. The internal storage drive is not designed for frequent changes or replacement.
- Before replacing the internal storage drive, make a backup copy of all the data that you want to keep.
- Do not touch the contact edge of the internal storage drive. Otherwise, the internal storage drive might get damaged.
- Do not apply pressure to the internal storage drive.
- Do not make the internal storage drive subject to physical shocks or vibration. Put the internal storage drive on a soft material, such as cloth, to absorb physical shocks.

For access, do the following:

1. Remove the “Side cover” on page 59.
2. Remove the “Super capacitor module” on page 95.
3. Remove the “PCIe card and extender” on page 97.

#### Removal steps

1. Remove the M.2 SSD with its heatsink kit.

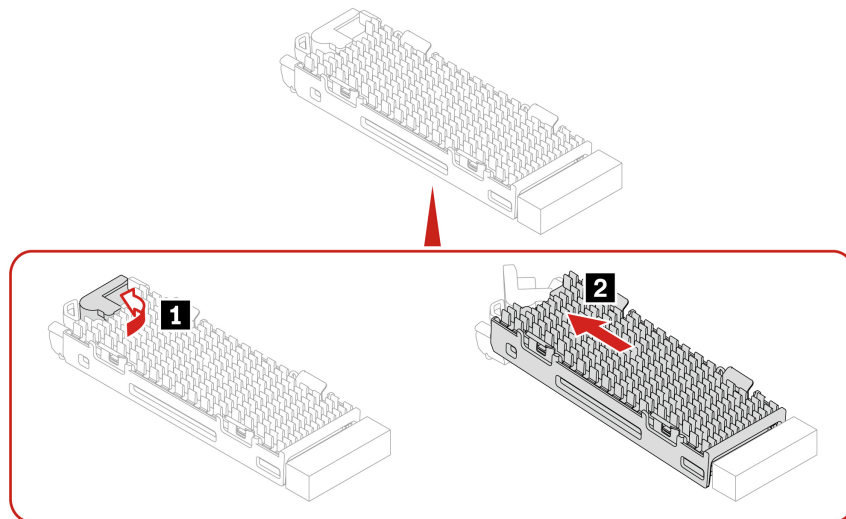

2. Remove the M.2 SSD from its heatsink kit.

- Gen 4 M.2 SSD

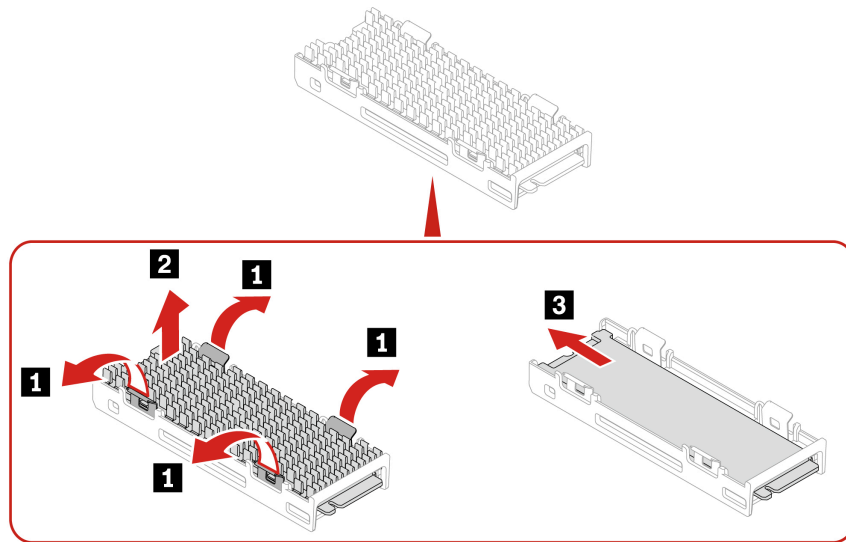

- Gen 5 M.2 SSD

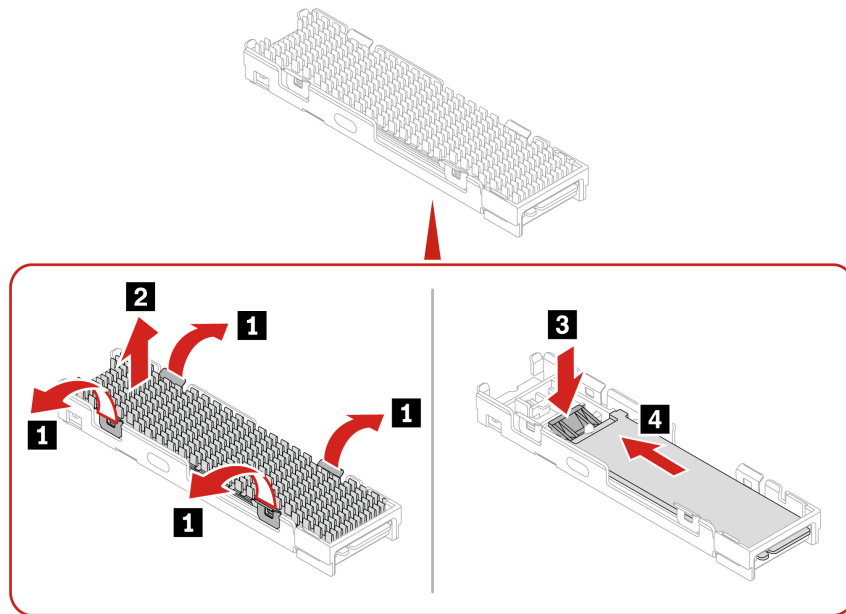

**Note:** Remove the film that covers the thermal pad (if any) when installing the M.2 SSD.

## M.2 SSD holder

### Prerequisite

Before you start, read [Generic Safety and Compliance Notices](#), and print the following instructions.



Before you open the computer cover, turn off the computer and wait several minutes until the computer is cool.

For access, do the following:

1. Remove the “Side cover” on page 59.
2. Remove the “Super capacitor module” on page 95.
3. Remove the “PCIe card and extender” on page 97.
4. Remove the “Onboard M.2 SSD and its heatsink kit” on page 82.

### Removal steps

Remove the M.2 SSD holder.

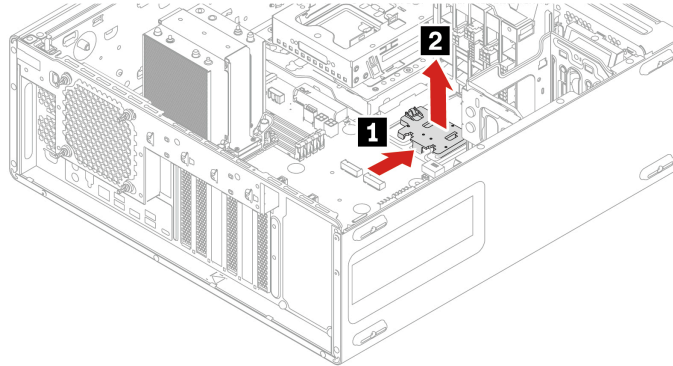

## M.2 SSD on an M.2 SSD PCIe adapter

### Prerequisite

Before you start, read *Generic Safety and Compliance Notices*, and print the following instructions.

**Attention:** The internal storage drive is sensitive. Inappropriate handling might cause damage and permanent loss of data. When handling the internal storage drive, observe the following guidelines:

- Replace the internal storage drive only for repair. The internal storage drive is not designed for frequent changes or replacement.
- Before replacing the internal storage drive, make a backup copy of all the data that you want to keep.
- Do not touch the contact edge of the internal storage drive. Otherwise, the internal storage drive might get damaged.
- Do not apply pressure to the internal storage drive.
- Do not make the internal storage drive subject to physical shocks or vibration. Put the internal storage drive on a soft material, such as cloth, to absorb physical shocks.

For access, do the following:

1. Remove the “Side cover” on page 59.
2. Remove the “Super capacitor module” on page 95.
3. Remove the “NVLINK bridge” on page 94, if any.
4. Remove the M.2 SSD PCIe adapter. See “PCIe card and extender” on page 97.

### Removal steps of type 1 M.2 SSD on an M.2 SSD PCIe adapter

1. Open the cover.

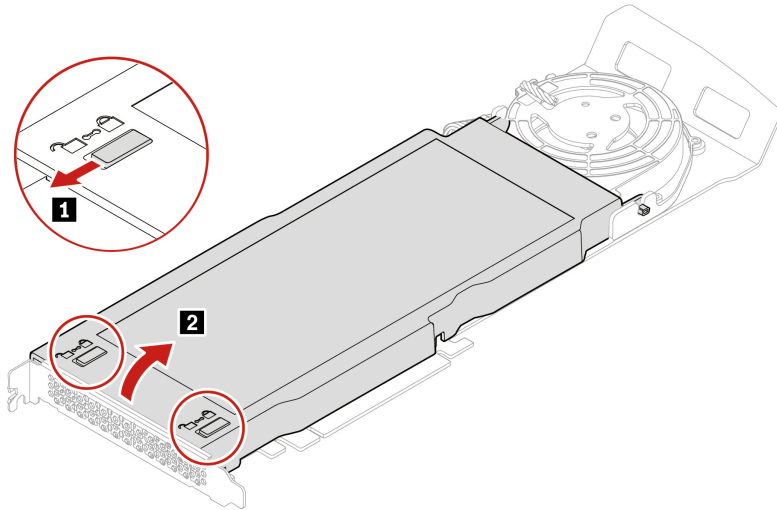

2. Remove the M.2 SSD heat sink.

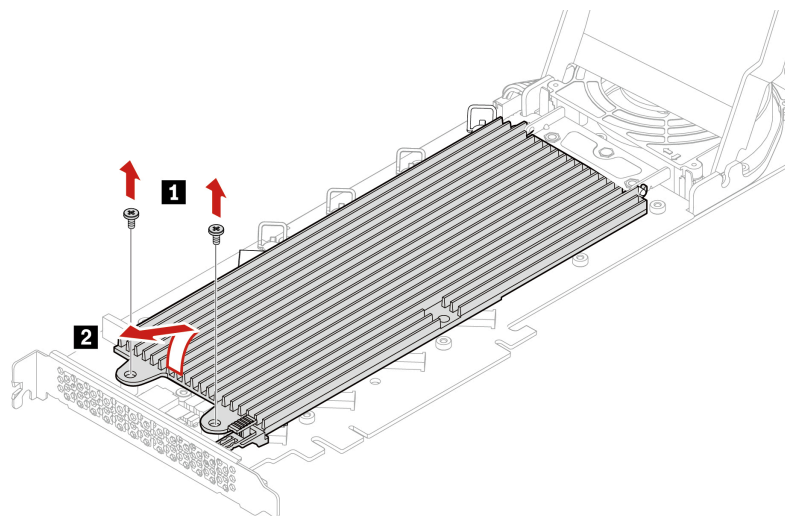

Screw (quantity)	Color	Torque
M3_H5 Zn coated (2)	Black	3.0 ± 0.2 lb/in

3. Pull the handle of the retention latch outward to release the M.2 SSD. Then, remove the M.2 SSD from the PCIe adapter.

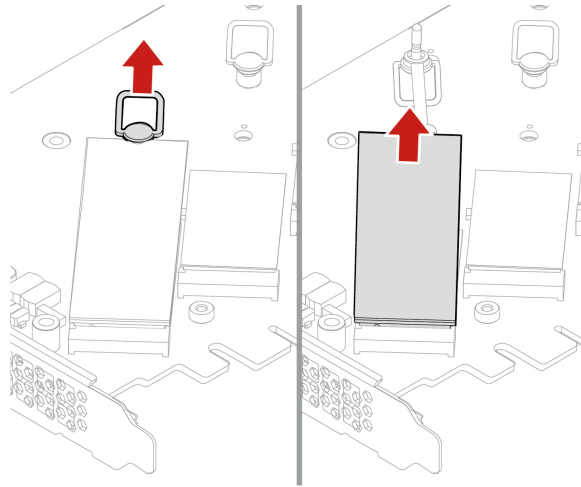

### Installation steps of type 1 M.2 SSD on an M.2 SSD PCIe adapter

1. If necessary, move the retention latch to an appropriate location to suit the length of the new M.2 SSD.

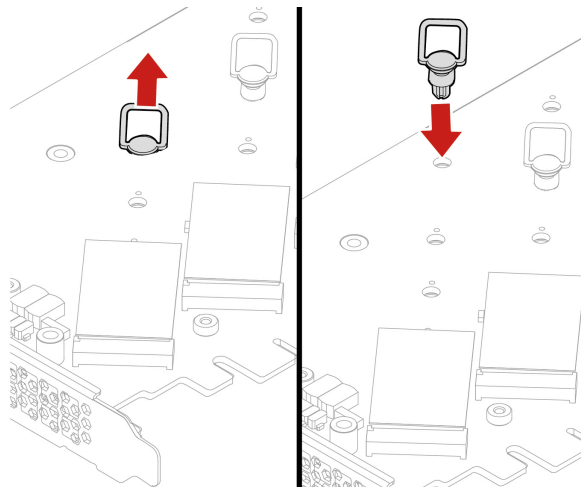

Remove the film on the thermal pad on which you want to install the M.2 SSD. Pull the handle of the retention latch outward to the open position.

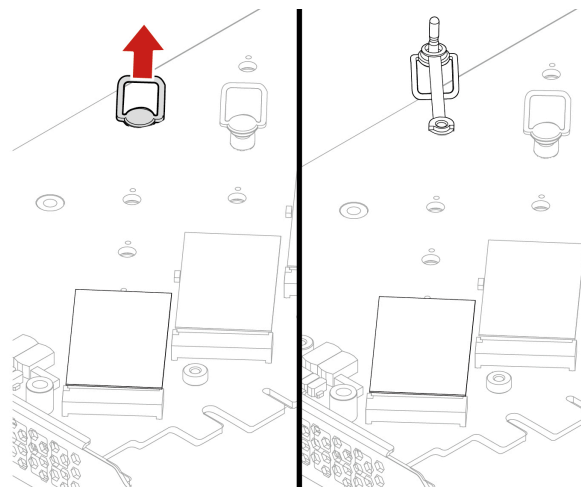

2. Install the M.2 SSD. Then, insert the plug of the retention latch into the hole to secure the new drive. Do not touch the circuit board of the M.2 SSD.

**Note:** Install M.2 SSD in the alphabetic order as shown.

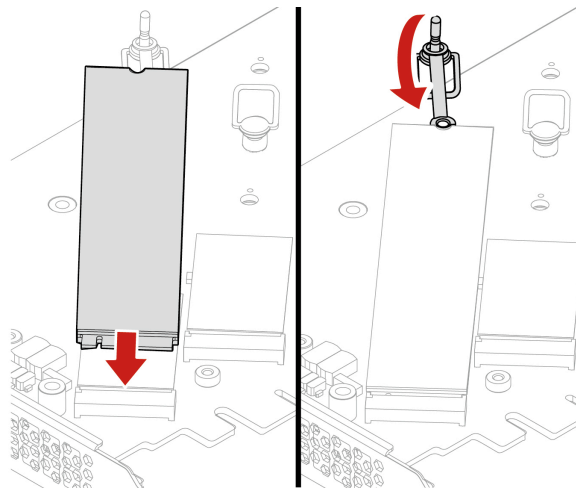
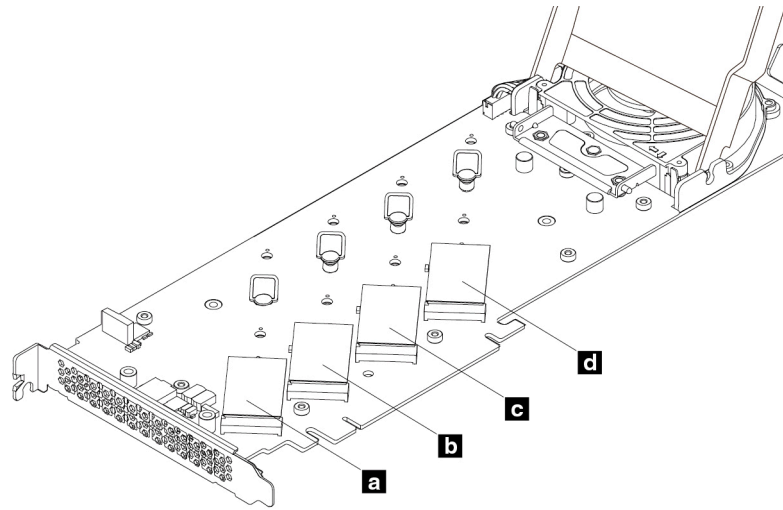

3. Install the M.2 SSD heat sink.

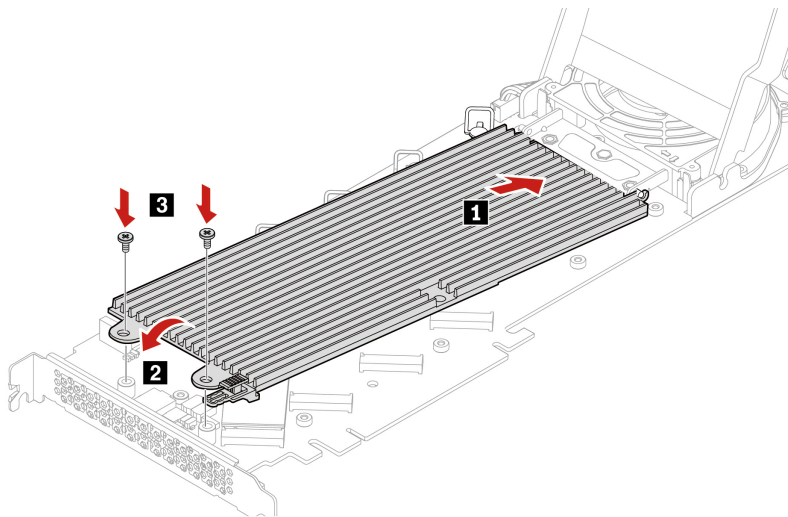

4. Close the cover and lock it.

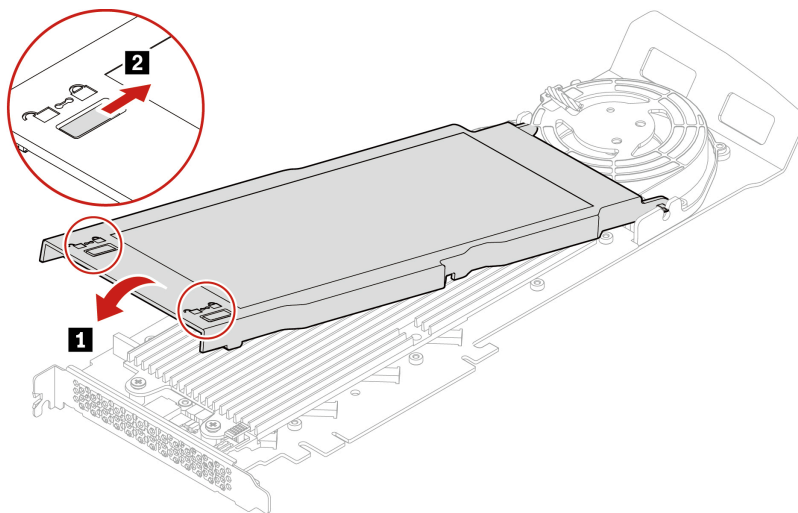

**Note:** Install the M.2 SSD PCIe adapter in a PCIe x16 card slot on the system board. See “PCIe card installation rule” on page 101.

#### Removal steps of type 2 M.2 SSD on an M.2 SSD PCIe adapter

1. Rotate the lock to the open position to open the cover.

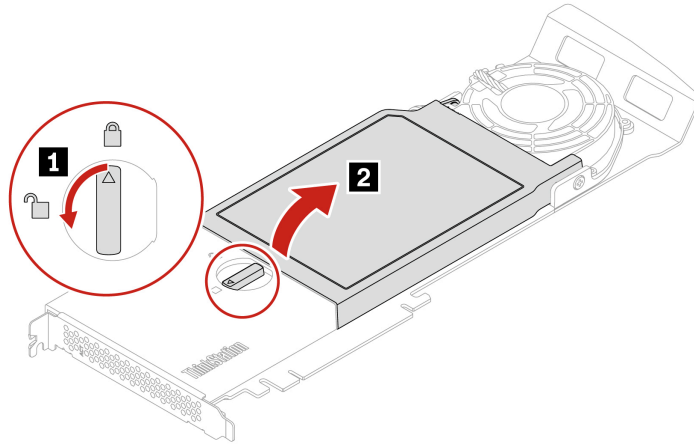

2. Pull the handle of the retention latch outward to release the M.2 SSD. Then, remove the M.2 SSD from the PCIe adapter.

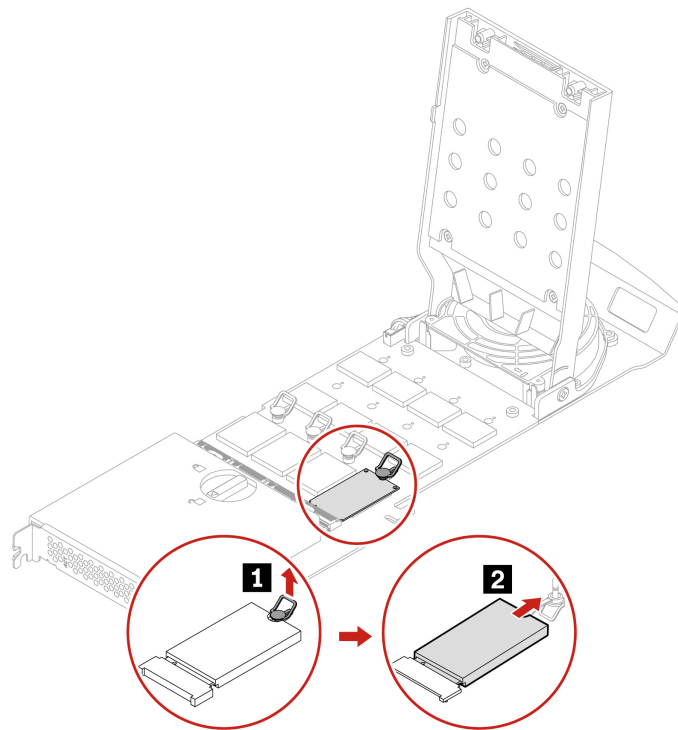

#### Installation steps of type 2 M.2 SSD on an M.2 SSD PCIe adapter

1. If necessary, move the retention latch to an appropriate location to suit the length of the new M.2 SSD.

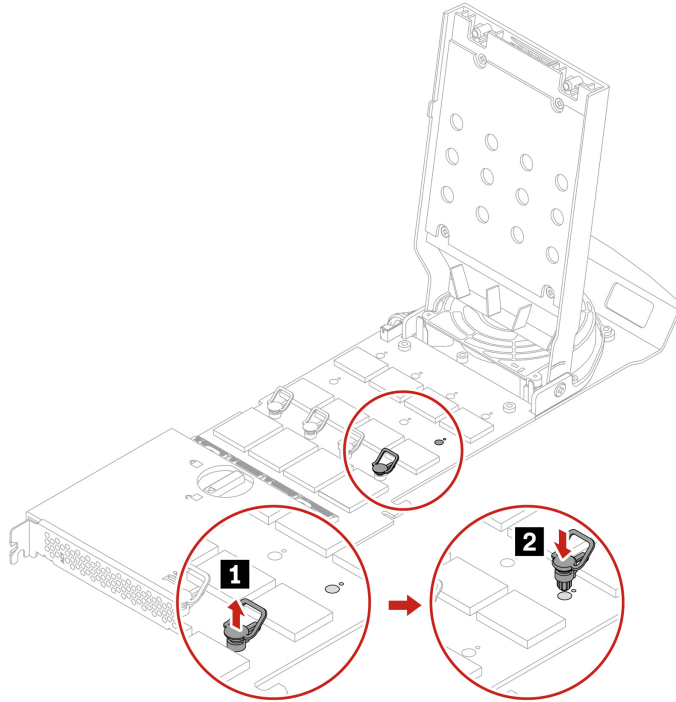

Remove the film on the thermal pad on which you want to install the M.2 SSD. Pull the handle of the retention latch outward to the open position.

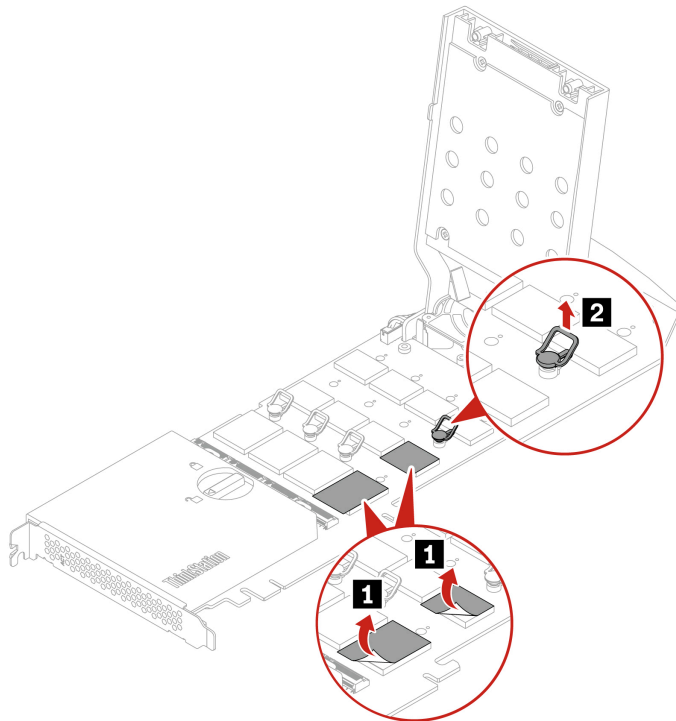

2. Install the M.2 SSD. Then, insert the plug of the retention latch into the hole to secure the new drive. Do not touch the circuit board of the M.2 SSD.

**Notes:**

- Install M.2 SSDs in the following order as shown:

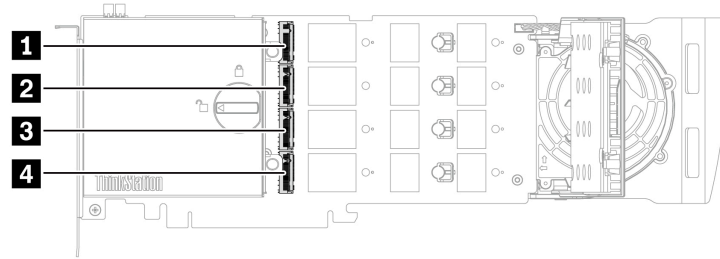

- For better performance, it's recommended that the generation of M.2 SSD match with the generation of M.2 SSD PCIe adapter. For example, install Gen 4 M.2 SSD on Gen 4 M.2 SSD PCIe adapter and install Gen 5 M.2 SSD on Gen 5 M.2 SSD PCIe adapter.

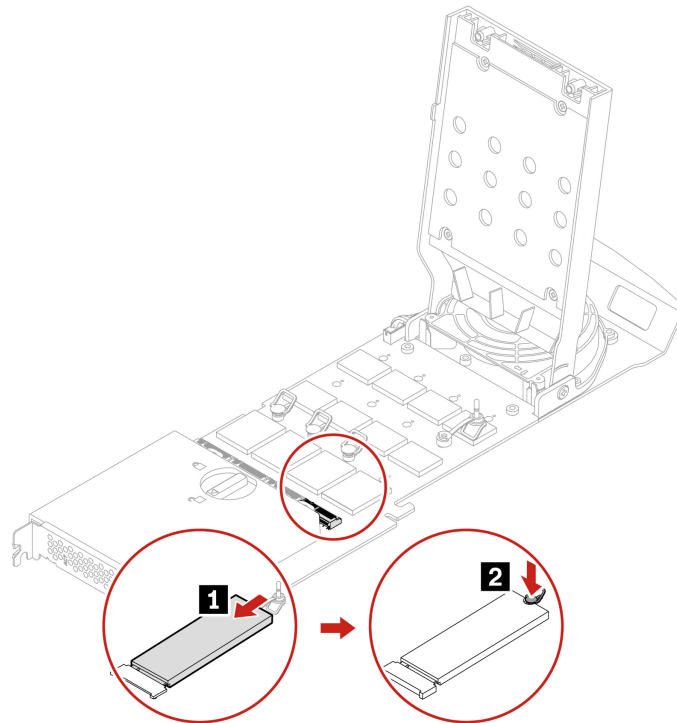

3. Rotate the lock to the close position to close the cover.

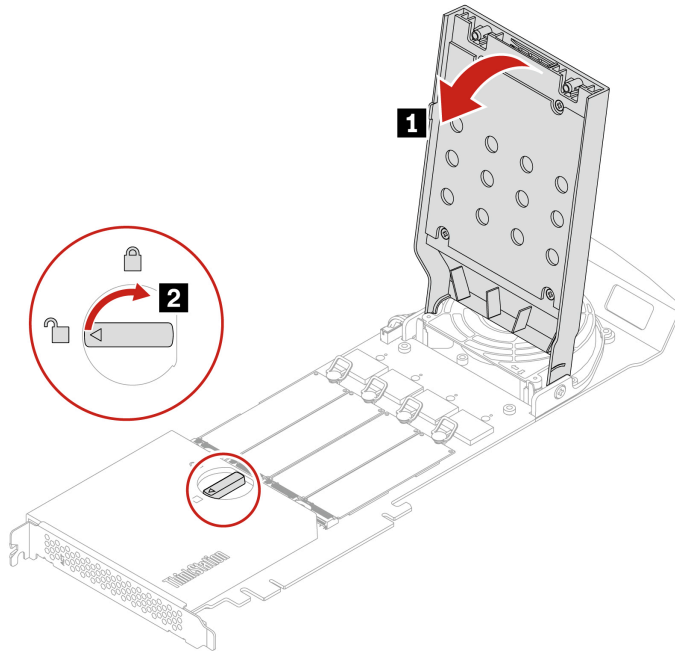

**Note:** Install the M.2 SSD PCIe adapter in a PCIe x16 card slot on the system board. See “PCIe card installation rule” on page 101.

---

## PCIe cards

By reading this section, you will learn to replace PCIe cards, including graphics cards, in your computer.

## NVLINK retainer

### Prerequisite

Before you start, read [Generic Safety and Compliance Notices](#), and print the following instructions.



Before you open the computer cover, turn off the computer and wait several minutes until the computer is cool.

For access, remove the “Side cover” on page 59.

### Removal steps

Remove the NVLINK retainer.

**Note:** The NVLINK retainer is only available on some Graphics cards.

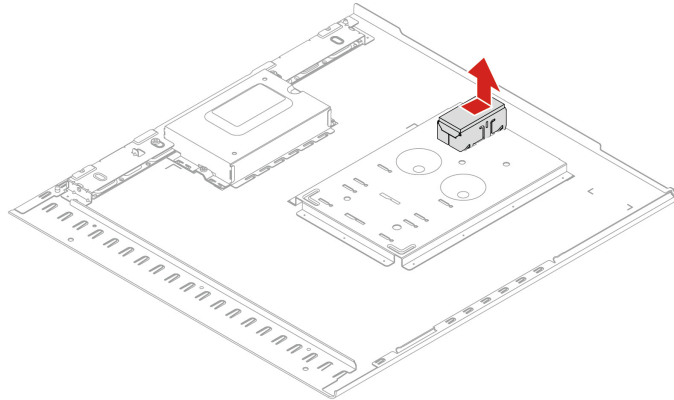

## NVLINK bridge

### Prerequisite

Before you start, read [Generic Safety and Compliance Notices](#), and print the following instructions.

For access, remove the “Side cover” on page 59.

### Removal steps

Remove the NVLINK bridge.

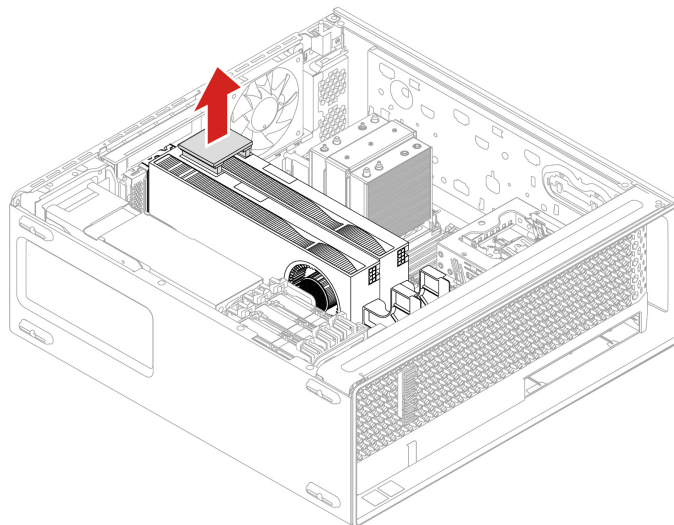

### Installation steps

Install the NVLINK bridge.

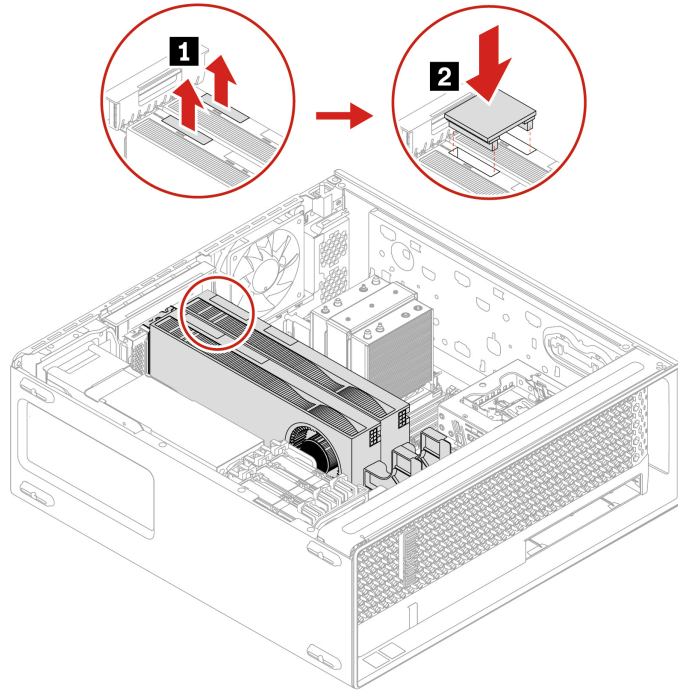

**Note:** To install NVLINK bridge, make sure you have installed NVLINK retainer.

## Super capacitor module

### Prerequisite

Before you start, read *Generic Safety and Compliance Notices*, and print the following instructions.

For access, remove the “Side cover” on page 59.

### Removal steps

Remove the super capacitor module.

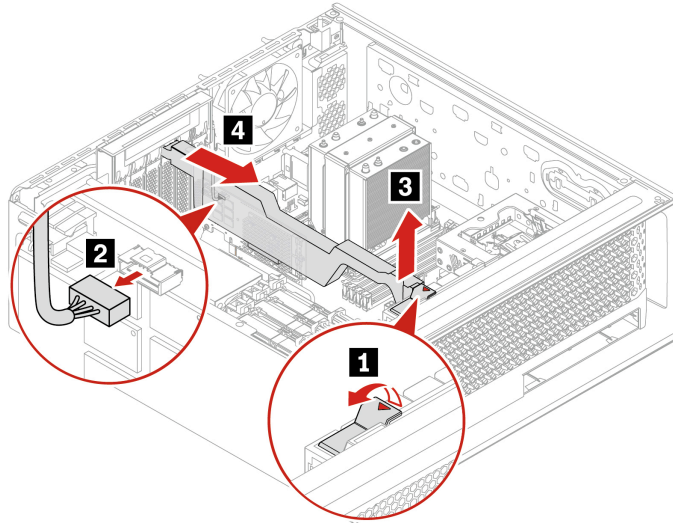

**Note:** When installing a new super capacitor module, connect the super capacitor module cable to the super capacitor module connector (J14) on the RAID card.

## PCIe bracket

### Prerequisite

Before you start, read [Generic Safety and Compliance Notices](#), and print the following instructions.

For access, remove the “Side cover” on page 59.

### Removal steps

Remove the PCIe bracket.

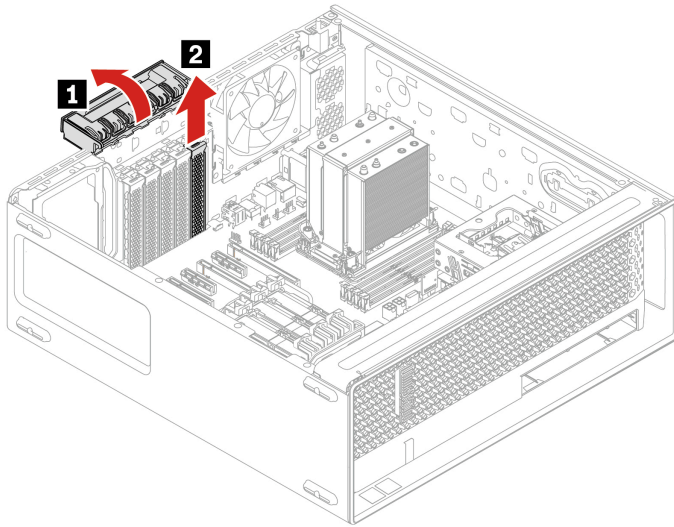

## PCIe card and extender

### Prerequisite

Before you start, read [Generic Safety and Compliance Notices](#), and print the following instructions.

For access, do the following:

1. Remove the following parts, if any, in order.
  - “Side cover” on page 59
  - “NVLINK bridge” on page 94
2. Record the PCIe card cable routing and connections (if any), then disconnect the cables from the system board.

### Replacement steps for half-length PCIe card

1. Remove the PCIe card retainer. The PCIe card retainer is only available on some PCIe cards.

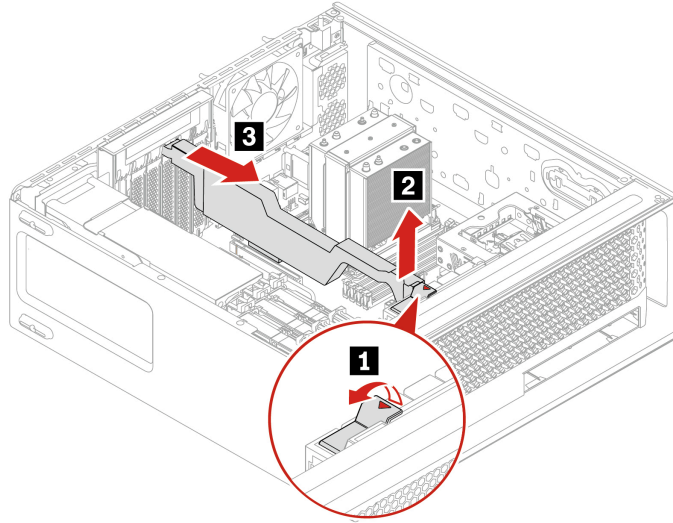

2. Remove the PCIe card. The card might fit tightly into the slot. If necessary, alternately move each side of the card a small amount until the card is removed from the slot.

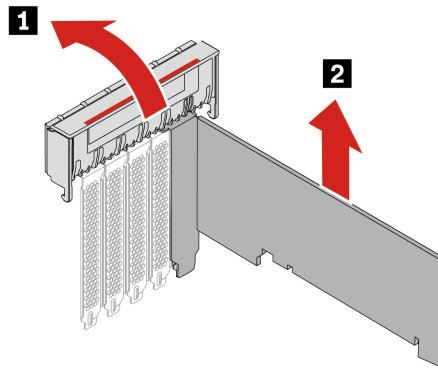

**Note:** For some Ethernet adapter cards, the following fiber modules can be removed.

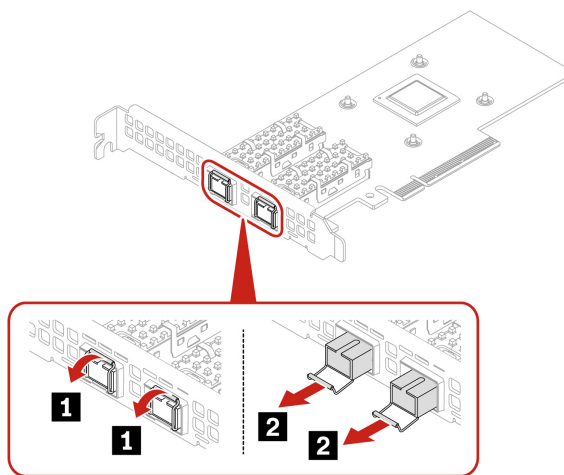

3. Install the PCIe card and other removed parts in reverse order.

**Note:** For PCIe card installation order and special installation rules for certain PCIe cards, see “PCIe card installation rule” on page 101.

### Replacement steps for full-length PCIe card

1. Remove the PCIe card.
  - a. Unlock the front card guide.
  - b. Open the handle.
  - c. Remove the screws that fix the PCIe card to the chassis (if any).
  - d. Remove the PCIe card. The card might fit tightly into the slot. If necessary, alternately move each side of the card a small amount until the card is removed from the slot.

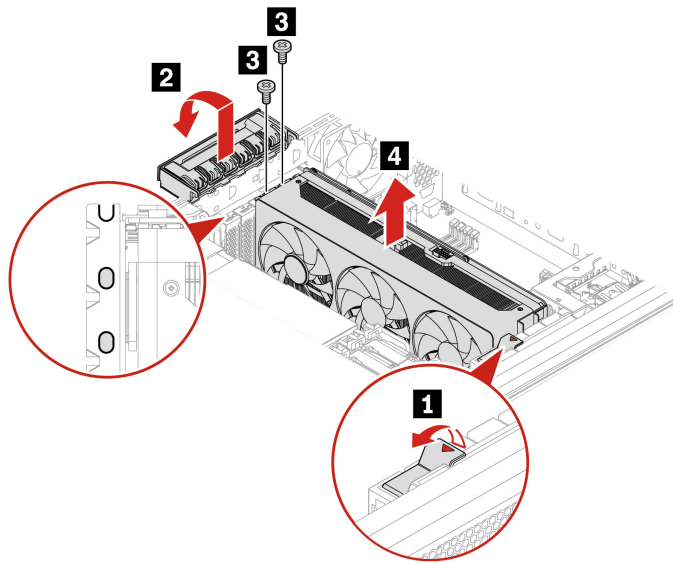

Screw specification	Quantity	Torque
M3.5 x 5 mm, Ni coated, black	2	5 ± 0.5 lb/in

2. Remove the PCIe extender if needed.
  - For computer models with GFX RTX 4000 Ada, the graphics card and the PCIe card extender work as a CRU assembly. Do not try to remove the extender.
  - For computer models with double-width or wider graphics cards (such as NVIDIA RTX 6000 Ada and GeForce RTX 4080/5080), the PCIe card extender is a customized CRU part. You can remove it according to the following illustration.
    - Type-1

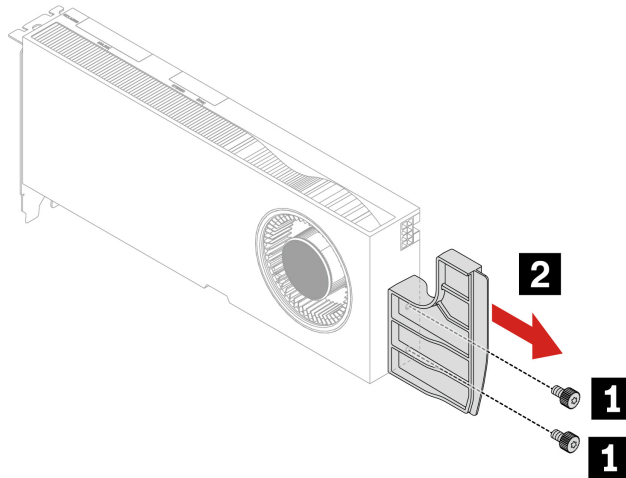

Screw specification	Quantity	Torque
M3 x 5.5 mm, Ni coated, black	2	3-3.5 lb/in

- Type-2

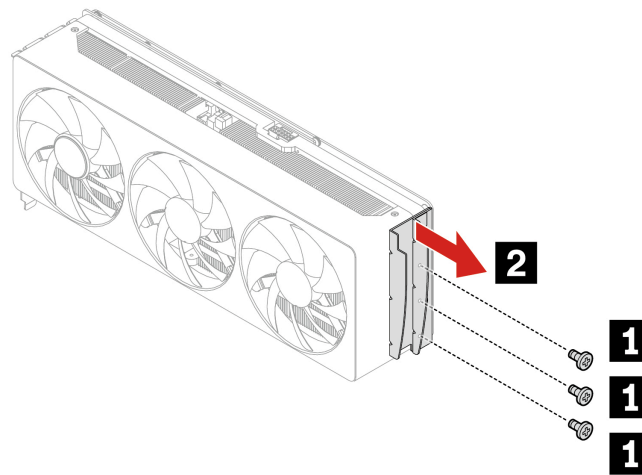

Screw specification	Quantity	Torque
M3 x 5 mm, Ni coated, black	3	3 ± 0.5 lb/in

3. Install the PCIe card and other removed parts in reverse order.

**Notes:**

- For compatible models without a pre-installed GeForce 5080 PCIe card, you may need a PH2 screwdriver to access two screws above the second and third PCIe brackets on the rear panel, as the card doesn't include chassis mounting screws.

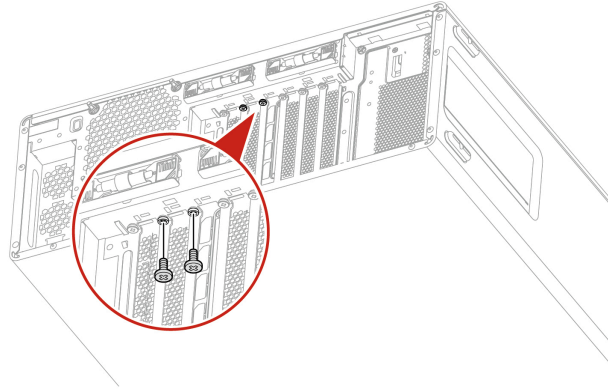

- For PCIe card installation order and special installation rules for certain PCIe cards, see “PCIe card installation rule” on page 101.

## PCIe card installation rule

Install PCIe cards according to the following order and special rules for certain PCIe cards.

- **Installation order**

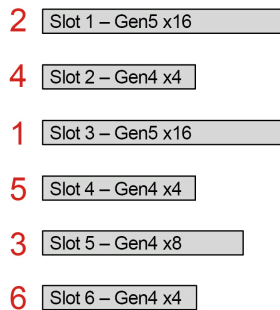

Figure 3. PCIe card installation order

- **Special installation rules for certain PCIe cards**

PCIe card	Installation rules
For all graphic cards	<ul style="list-style-type: none"> <li>– Ensure that at least one graphic card is installed.</li> <li>– If more than two graphic cards is installed, ensure that they are the same.</li> </ul>
Nvidia GeForce graphic cards	Install in slot 1.
Gen 3 M.2 SSD PCIe adapter (Medina I)	Install in slot 1.

PCIe card	Installation rules
Gen 4 M.2 SSD PCIe adapter (Medina II)	Install in slot 1.
Gen 5 M.2 SSD PCIe adapter (Medina Gen 5)	Install in slot 1.
NVIDIA ConnectX-6 Ethernet Adapter card	Install in slot 1.
Thunderbolt card	<ul style="list-style-type: none"> <li>– Install in slot 6, slot 4, or slot 2</li> <li>– Ensure that at least one graphic card with two DisplayPort connectors is installed.</li> </ul>
BMC card (for selected models)	Install in slot 5.

## Cable connection

When installing PCIe cards, follow the cable connection rule if need.

**Note:** The connectors on the cards or system board might look slightly different from the illustrations.

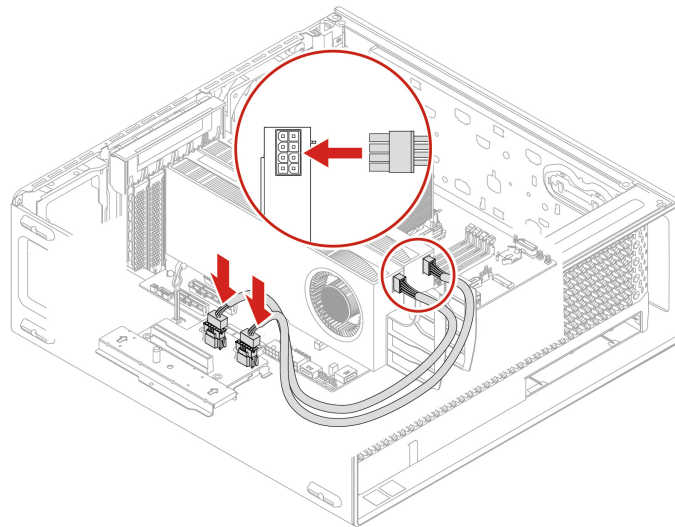

Figure 4. Cable connection for GFX RTX A4500/RTX A5500/RTX A6000/RTX 5880 with 1000-watt power supply assembly

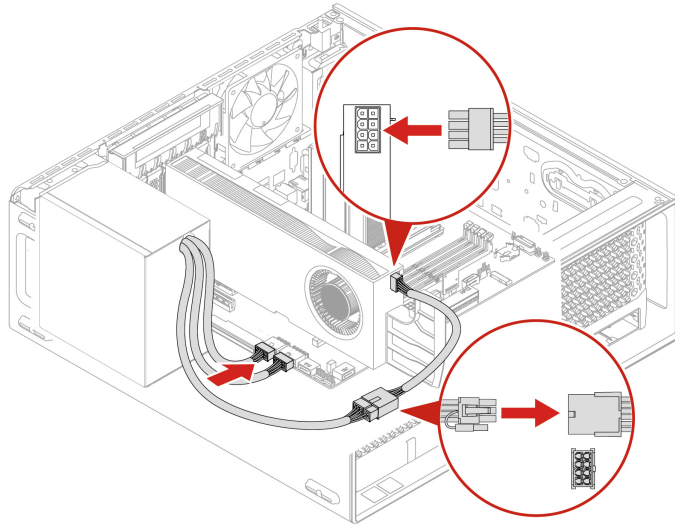

Figure 5. Cable connection for GFX RTX A4500/RTX A5500/RTX A6000/RTX 5880 with 750-watt power supply assembly

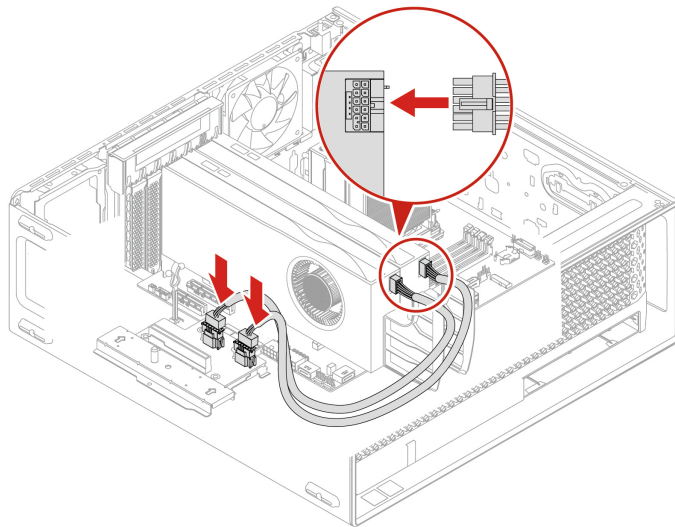

Figure 6. Cable connection for GFX RTX 4000 Ada / RTX 4500 Ada / RTX 5000 Ada with 1000-watt power supply assembly

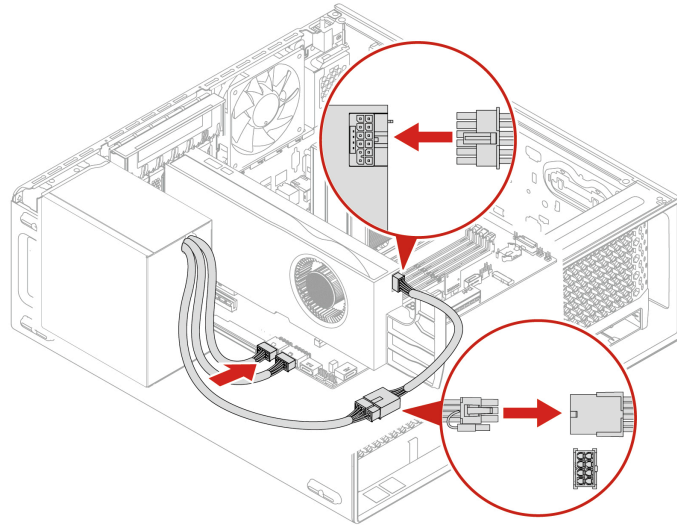

Figure 7. Cable connection for GFX RTX 4000 Ada /RTX 4500 Ada /RTX 5000 Ada with 750-watt power supply assembly

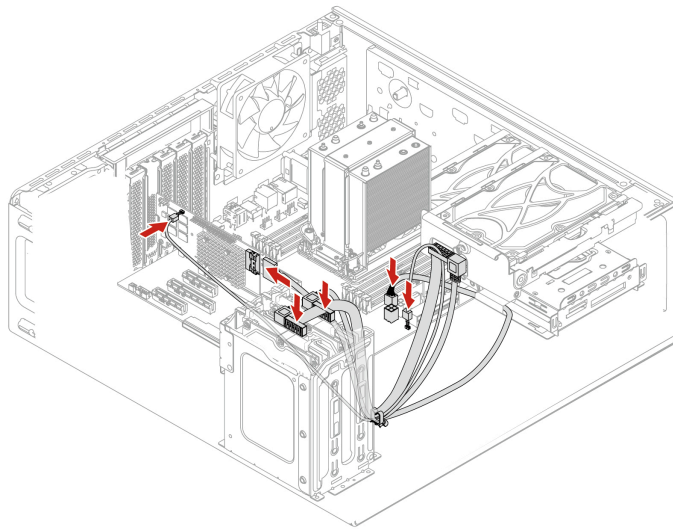

Figure 8. Cable connection for Broadcom 9540-8i Raid card

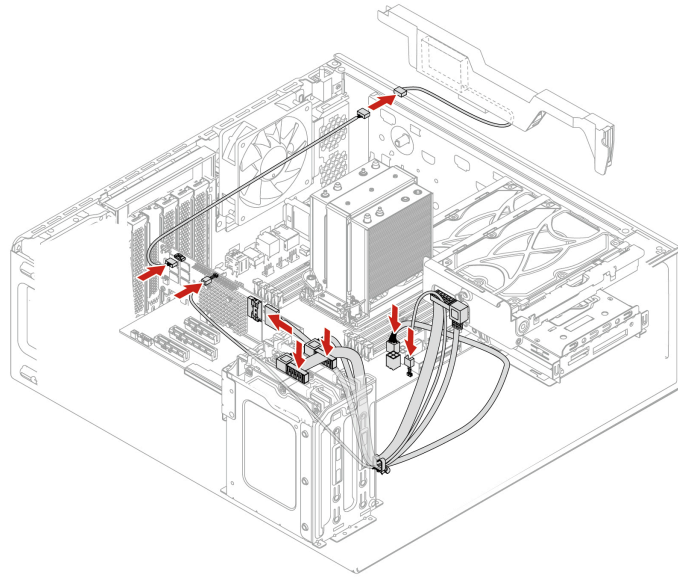

Figure 9. Cable connection for Broadcom 940-8i RAID card

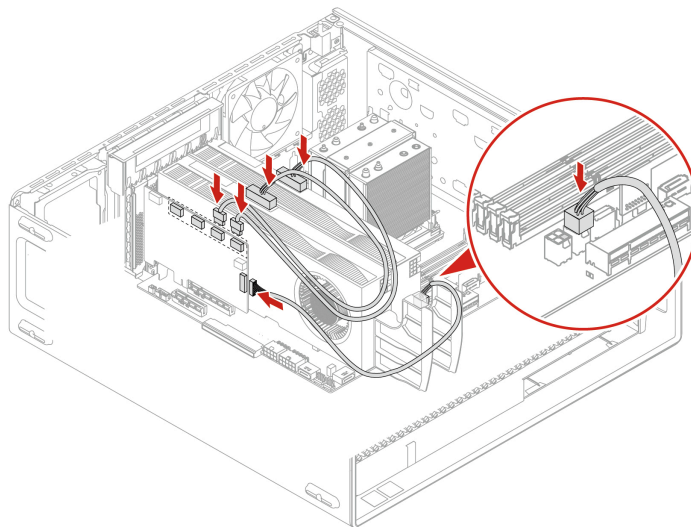

Figure 10. Cable connection for NVIDIA Quadro SYNC II card

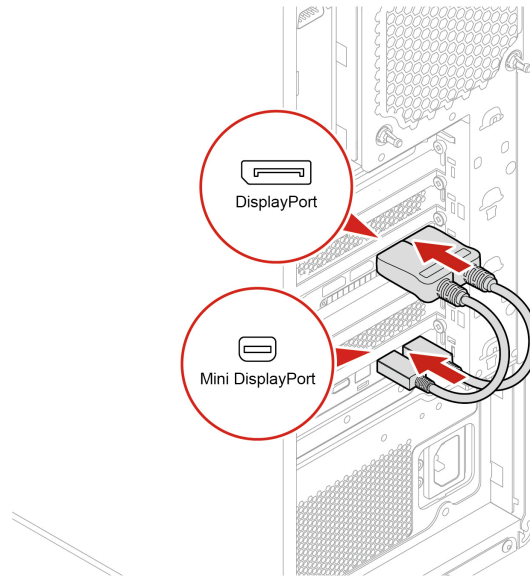

Figure 11. Cable connection for Thunderbolt card

---

## BMC card

### Prerequisite

Before you start, read *Generic Safety and Compliance Notices*, and print the following instructions.

For access, do the following:

1. Remove the “Side cover” on page 59.
2. Remove the “PCIe bracket ” on page 96 if any.

### Removal steps

1. Vertically pull the BMC cable from the connector on the BMC card.
2. Open the handle and remove the BMC card.

**Note:** The card might fit tightly into the slot. If necessary, alternately move each side of the card a small amount until the card is removed from the slot.

3. Vertically pull the BMC cable from the connector on the system board.

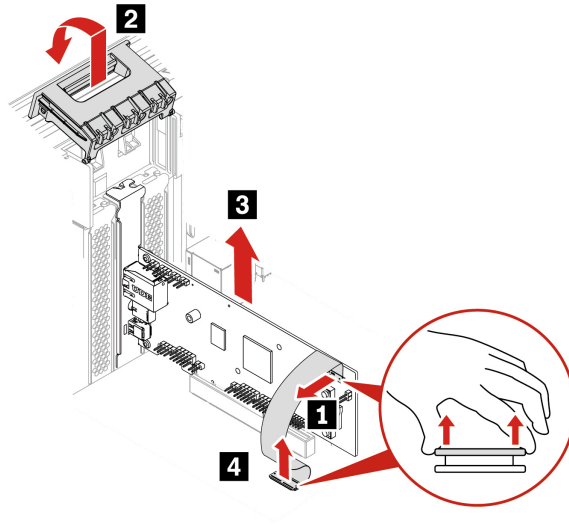

### Installation steps

1. Connect the BMC cable with the “MB” end to the system board.
2. Install the BMC card in PCIe slot 5.
3. Connect the BMC cable with the “BMC” end to the BMC card.
4. Close the handle.

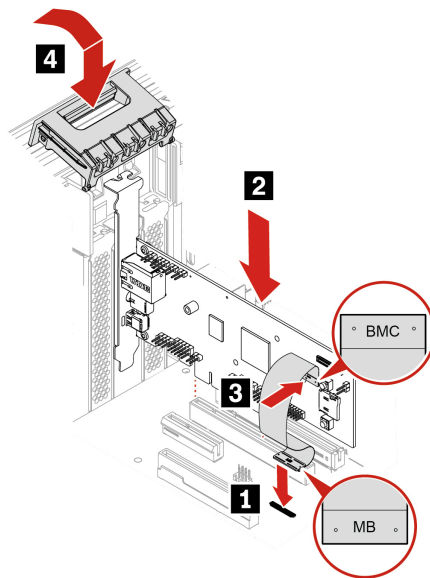

---

## Wi-Fi card

### Prerequisite

Before you start, read *Generic Safety and Compliance Notices*, and print the following instructions.

For access, remove the “Side cover” on page 59.

## Removal steps

Remove the Wi-Fi card.

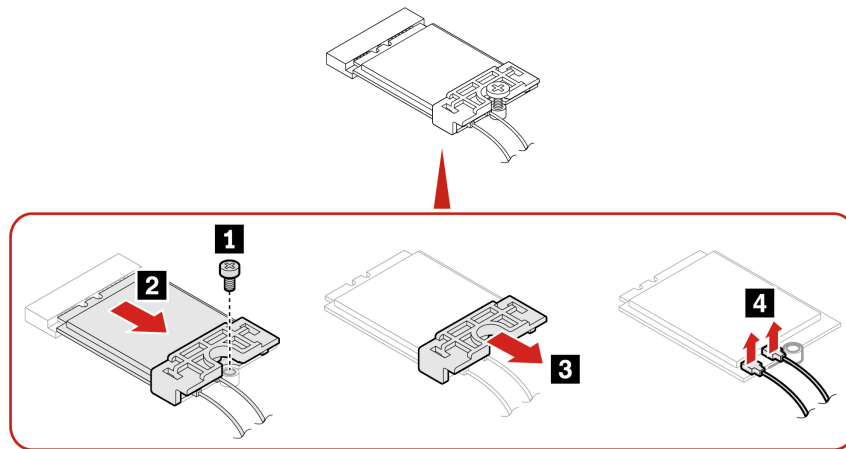

Screw (quantity)	Color	Torque
M2 x 3mm, Zi coated (1)	Black	1.5 ± 0.2 lb/in

**Note:** During installation, ensure that you connect the gray cable to the connector labeled AUX on the card, and the black cable to the connector labeled MAIN.

---

## Wi-Fi antenna

### Prerequisite

Before you start, read *Generic Safety and Compliance Notices*, and print the following instructions.

For access, do the following:

1. Remove the “Side cover” on page 59.
2. Remove the “Top cover” on page 61.
3. Remove the “Optional HDD and its cage” on page 77.
4. Remove the “Wi-Fi card” on page 107.

### Removal steps

Remove the Wi-Fi antenna.

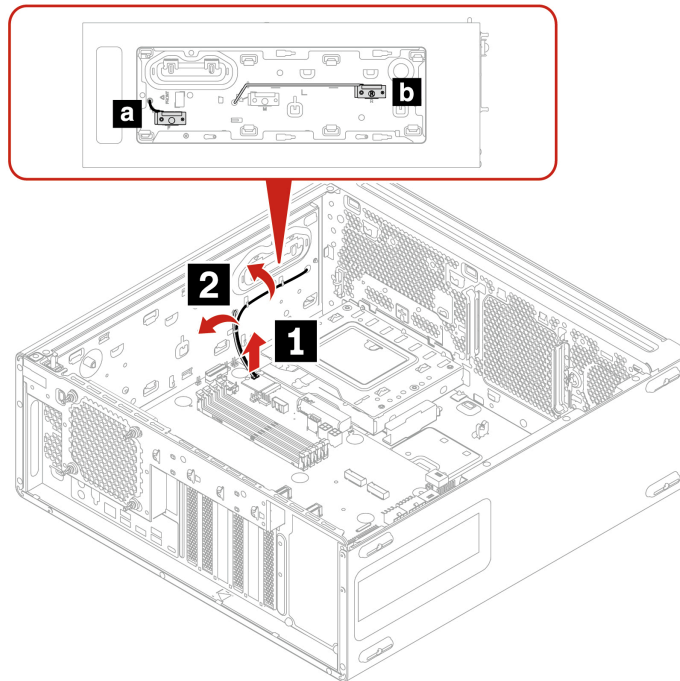

---

## Ambient temp sensor

### Prerequisite

Before you start, read [Generic Safety and Compliance Notices](#), and print the following instructions.

For access, do the following:

1. Remove the “Side cover” on page 59.
2. Remove the “Optional HDD and its cage” on page 77.
3. Remove the “Flex bay fan” on page 74.

### Removal steps

Remove the ambient temp sensor.

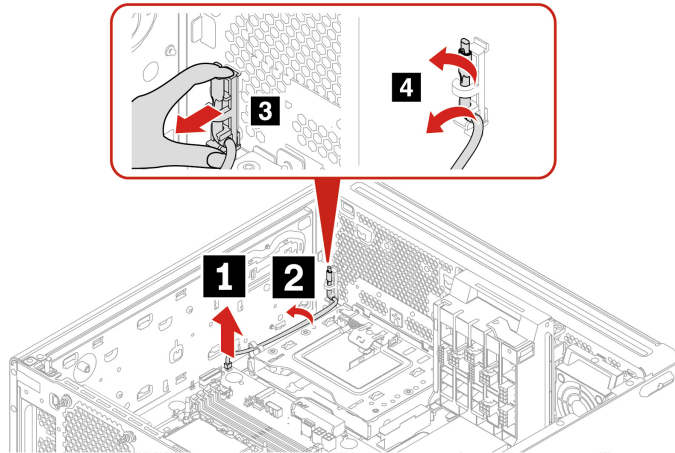

---

## CPU heat sink

### Prerequisite

Before you start, read *Generic Safety and Compliance Notices*, and print the following instructions.



The heat sink might be very hot. Before you open the computer cover, turn off the computer and wait several minutes until the computer is cool.

For access, do the following:

1. Remove the “Side cover” on page 59.
2. Remove the “Memory fan duct” on page 72.

### Removal steps

1. Follow the following sequence to loosen the four screws that secure the CPU heat sink to the system board. Then, lift the CPU heat sink off the system board.
  - Partially loosen screw **1a**, fully loosen screw **1b**, and then fully loosen screw **1a**.
  - Partially loosen screw **1c**, fully loosen screw **1d**, and then fully loosen screw **1c**.

#### Notes:

- Carefully loosen the four screws to avoid any possible damage to the system board. The four screws cannot be removed from the CPU heat sink.
- Use T30 screw bit with torque  $10 \pm 1$  in-lb to loosen the four screws of CPU heatsink.
- You might have to gently twist the CPU heat sink to free it from the CPU.

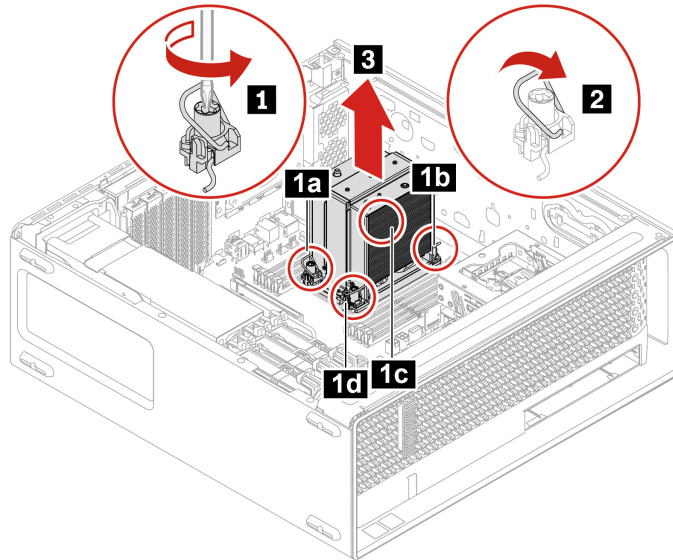

---

## CPU

### Prerequisite

Before you start, read *Generic Safety and Compliance Notices*, and print the following instructions.

### CAUTION:



**Avoid contact with hot components inside the computer. During operation, some components become hot enough to burn the skin. Before you open the computer cover, turn off the computer, disconnect power, and wait approximately 10 minutes for the components to cool.**

**Note:** Do not drop anything onto the CPU socket while it is exposed. The socket pins must be kept as clean as possible.

For access, do the following:

1. Remove the “Side cover” on page 59.
2. Remove the “Memory fan duct” on page 72.
3. Remove the “CPU heat sink” on page 110.

### Removal steps

Remove the CPU.

**Note:** Touch only the edges of the CPU. Do not touch the gold contacts on the bottom.

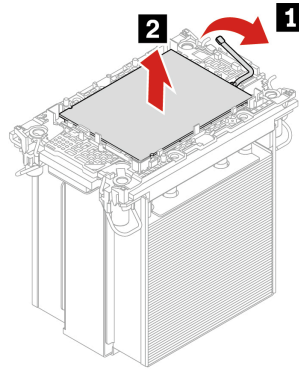

### Installation steps

Install the CPU.

### Notes:

- Before you attach the CPU to the computer, clean all thermal grease that has been used and then apply new thermal grease. Apply new thermal grease at an amount of 2.5 grams, on the parts marked **a** as shown in the following illustrations. Either too much or too less application of grease can cause a thermal problem due to imperfect contact with a component.

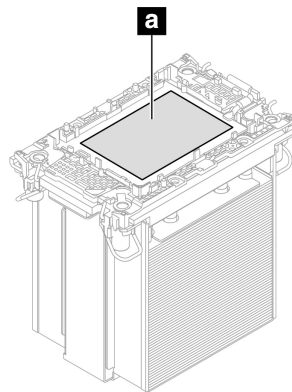

*Figure 12. Illustrations of the thermal grease area*

- Touch only the edges of the CPU. Do not touch the gold contacts on the bottom.

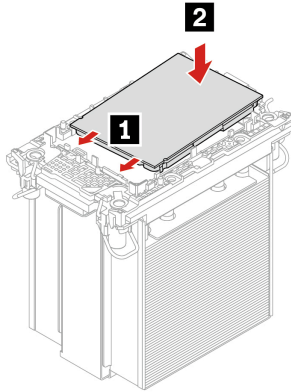

---

## Cover presence switch

### Prerequisite

Before you start, read *Generic Safety and Compliance Notices*, and print the following instructions.

For access, do the following:

1. Remove the “Side cover” on page 59.
2. Remove the “Memory fan duct” on page 72.
3. Remove the “Memory fan” on page 73.

### Removal steps

Remove the cover presence switch.

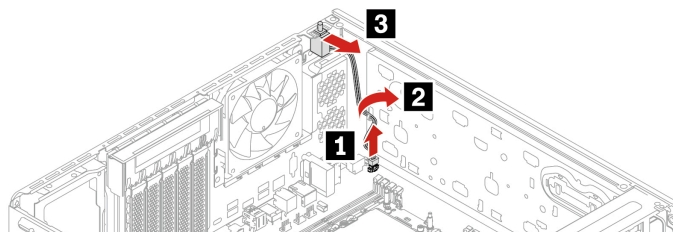

---

## Coin-cell battery

### Prerequisite

Before you start, read [Generic Safety and Compliance Notices](#), and print the following instructions.

For access, do the following:

1. Remove the “Side cover” on page 59.
2. Remove the “Memory fan duct” on page 72.

### About the coin-cell battery

The computer has a special type of memory that maintains the date, time, and settings for built-in features, such as parallel connector assignments (configurations). A coin-cell battery keeps this information active when you turn off the computer.

The coin-cell battery normally requires no charging or maintenance throughout its life; however, no coin-cell battery lasts forever. If the coin-cell battery fails, the date and time information is lost. An error message is displayed when you turn on the computer.

To dispose of the coin-cell battery, refer to the “Lithium coin-cell battery notice” in the *Safety and Warranty Guide*.

### Replacement steps

1. Press and hold the retaining clip, then pivot the coin-cell battery out of the holder.

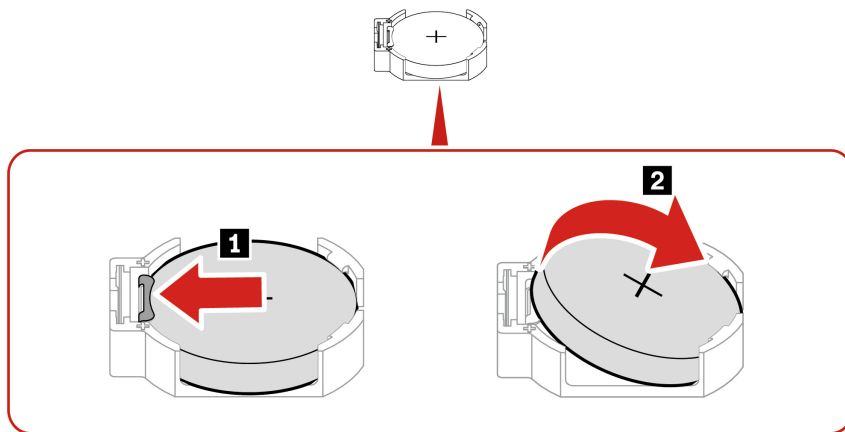

2. Tilt the coin-cell battery into the holder and press it down until it sits flat.

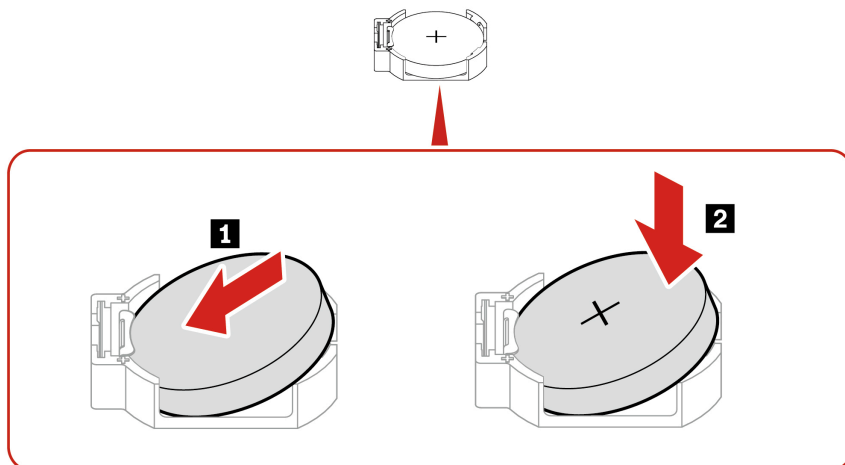

3. Install other removed parts and cables in reverse order.

### After replacement

After installing a new coin-cell battery, reset the system date and time in the UEFI BIOS menu.

---

## System board

### Prerequisite

Before you start, read *Generic Safety and Compliance Notices*, and print the following instructions.

### CAUTION:



**Avoid contact with hot components inside the computer. During operation, some components become hot enough to burn the skin. Before you open the computer cover, turn off the computer, disconnect power, and wait approximately 10 minutes for the components to cool.**

For access, do the following:

1. Remove these parts in order, if any:
  - “Side cover” on page 59
  - “Rear fan” on page 72
  - “Memory fan duct” on page 72
  - “Memory fan” on page 73
  - “Optional HDD and its cage” on page 77
  - “Flex bay fan” on page 74
  - “Flex bay cage” on page 78
  - “Flex module” on page 79
  - “Front panel I/O assembly” on page 62
  - “Internal speaker” on page 63
  - “Front fan” on page 71
  - “HDD and its bracket” on page 75
  - “HDD fan” on page 74
  - “Think LED cable” on page 64
  - “Power supply assembly” on page 65
  - “Power supply unit cover” on page 67
  - “Power distribution board and bracket” on page 68
  - “NVLINK bridge” on page 94
  - “Super capacitor module” on page 95
  - “PCIe card and extender” on page 97
  - “PCIe bracket ” on page 96
  - “M.2 SSD on an M.2 SSD PCIe adapter” on page 85
  - “Onboard M.2 SSD and its heatsink kit” on page 82
  - “M.2 SSD holder” on page 84
  - “BMC card” on page 106
  - “Wi-Fi card” on page 107
  - “Wi-Fi antenna” on page 108
  - “Ambient temp sensor” on page 109

- “CPU heat sink” on page 110
  - “CPU” on page 111
  - “Cover presence switch” on page 113
2. Record the cable routing and cable connections, and then disconnect all cables from the system board. See “System board illustration” on page 54.

### Removal steps

Remove the system board.

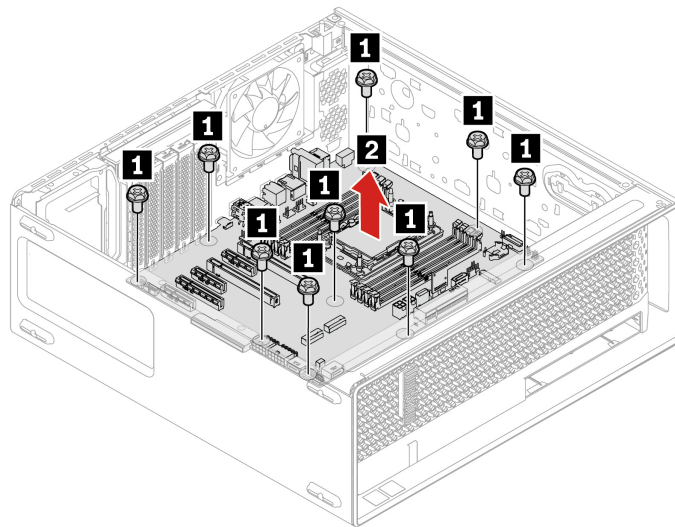

Screw (quantity)	Color	Torque
M3 x 5 mm, Nickel coated (9)	Black	5 ± 0.5 lb/in

### When installing:

Clean all thermal grease that have been used and then apply new thermal grease if needed.

---

## Appendix A. Important notice for Quebec consumers

In regard to section 79.18 of Quebec's Regulation respecting the application of the Consumer Protection Act, Lenovo in no way guarantees the availability of (a) replacement parts; (b) repair services; and (c) information necessary to maintain or repair the goods. For up-to-date information on the technical support and parts available for your purchase, please consult <https://support.lenovo.com/ca/en>.

En ce qui concerne l'article 79.18 du Règlement d'application de la Loi sur la protection du consommateur du Québec, Lenovo ne garantit en aucune façon la disponibilité des éléments suivants : (a) les pièces de rechange; (b) les services de réparation; et (c) les renseignements nécessaires à l'entretien à la réparation du bien. Pour obtenir des renseignements à jour sur le soutien technique et les pièces disponibles pour votre achat, veuillez consulter <https://support.lenovo.com/ca/fr>.

---

## Appendix B. Notices and trademarks

### Notices

Lenovo may not offer the products, services, or features discussed in this document in all countries. Consult your local Lenovo representative for information on the products and services currently available in your area. Any reference to a Lenovo product, program, or service is not intended to state or imply that only that Lenovo product, program, or service may be used. Any functionally equivalent product, program, or service that does not infringe any Lenovo intellectual property right may be used instead. However, it is the user's responsibility to evaluate and verify the operation of any other product, program, or service.

Lenovo may have patents or pending patent programs covering subject matter described in this document. The furnishing of this document does not give you any license to these patents. You can send license inquiries, in writing, to:

*Lenovo (United States), Inc.  
8001 Development Drive  
Morrisville, NC 27560  
U.S.A.  
Attention: Lenovo Director of Licensing*

LENOVO PROVIDES THIS PUBLICATION "AS IS" WITHOUT WARRANTY OF ANY KIND, EITHER EXPRESS OR IMPLIED, INCLUDING, BUT NOT LIMITED TO, THE IMPLIED WARRANTIES OF NON-INFRINGEMENT, MERCHANTABILITY OR FITNESS FOR A PARTICULAR PURPOSE. Some jurisdictions do not allow disclaimer of express or implied warranties in certain transactions, therefore, this statement may not apply to you.

Changes are made periodically to the information herein; these changes will be incorporated in new editions of the publication. To provide better service, Lenovo reserves the right to improve and/or modify the products and software programs described in the manuals included with your computer, and the content of the manual, at any time without additional notice.

The software interface and function and hardware configuration described in the manuals included with your computer might not match exactly the actual configuration of the computer that you purchase. For the configuration of the product, refer to the related contract (if any) or product packing list, or consult the distributor for the product sales. Lenovo may use or distribute any of the information you supply in any way it believes appropriate without incurring any obligation to you.

The products described in this document are not intended for use in implantation or other life support applications where malfunction may result in injury or death to persons. The information contained in this document does not affect or change Lenovo product specifications or warranties. Nothing in this document shall operate as an express or implied license or indemnity under the intellectual property rights of Lenovo or third parties. All information contained in this document was obtained in specific environments and is presented as an illustration. The result obtained in other operating environments may vary.

Lenovo may use or distribute any of the information you supply in any way it believes appropriate without incurring any obligation to you.

Any references in this publication to non-Lenovo Web sites are provided for convenience only and do not in any manner serve as an endorsement of those Web sites. The materials at those Web sites are not part of the materials for this Lenovo product, and use of those Web sites is at your own risk.

Any performance data contained herein was determined in a controlled environment. Therefore, the result obtained in other operating environments may vary significantly. Some measurements may have been made on development-level systems and there is no guarantee that these measurements will be the same on generally available systems. Furthermore, some measurements may have been estimated through extrapolation. Actual results may vary. Users of this document should verify the applicable data for their specific environment.

This document is copyrighted by Lenovo and is not covered by any open source license, including any Linux agreement(s) which may accompany software included with this product. Lenovo may update this document at any time without notice.

For the latest information or any questions or comments, contact or visit the Lenovo Web site:

- For computers purchased in mainland China  
<https://newsupport.lenovo.com.cn>
- For computers purchased outside mainland China  
<https://pcsupport.lenovo.com>

### **HEVC Standard**

This product may support digital video coding under certain versions of HEVC (High Efficiency Video Coding) standard and, if so, may be covered by patents at <https://accessadvance.com/advance-patent-lists/>.



### **Trademarks**

Lenovo, Lenovo logo, ThinkStation, and ThinkStation logo are trademarks of Lenovo. Intel, Core, and Thunderbolt are trademarks of Intel Corporation or its subsidiaries in the U.S. and/or other countries. Windows and Cortana are trademarks of the Microsoft group of companies. Mini DisplayPort (mDP) and DisplayPort are trademarks of the Video Electronics Standards Association. Wi-Fi is registered trademarks of Wi-Fi Alliance. USB-C is a registered trademark of USB Implementers Forum. All other trademarks are the property of their respective owners.

**Lenovo**