

Linux User Guide

Lenovo
ThinkStation

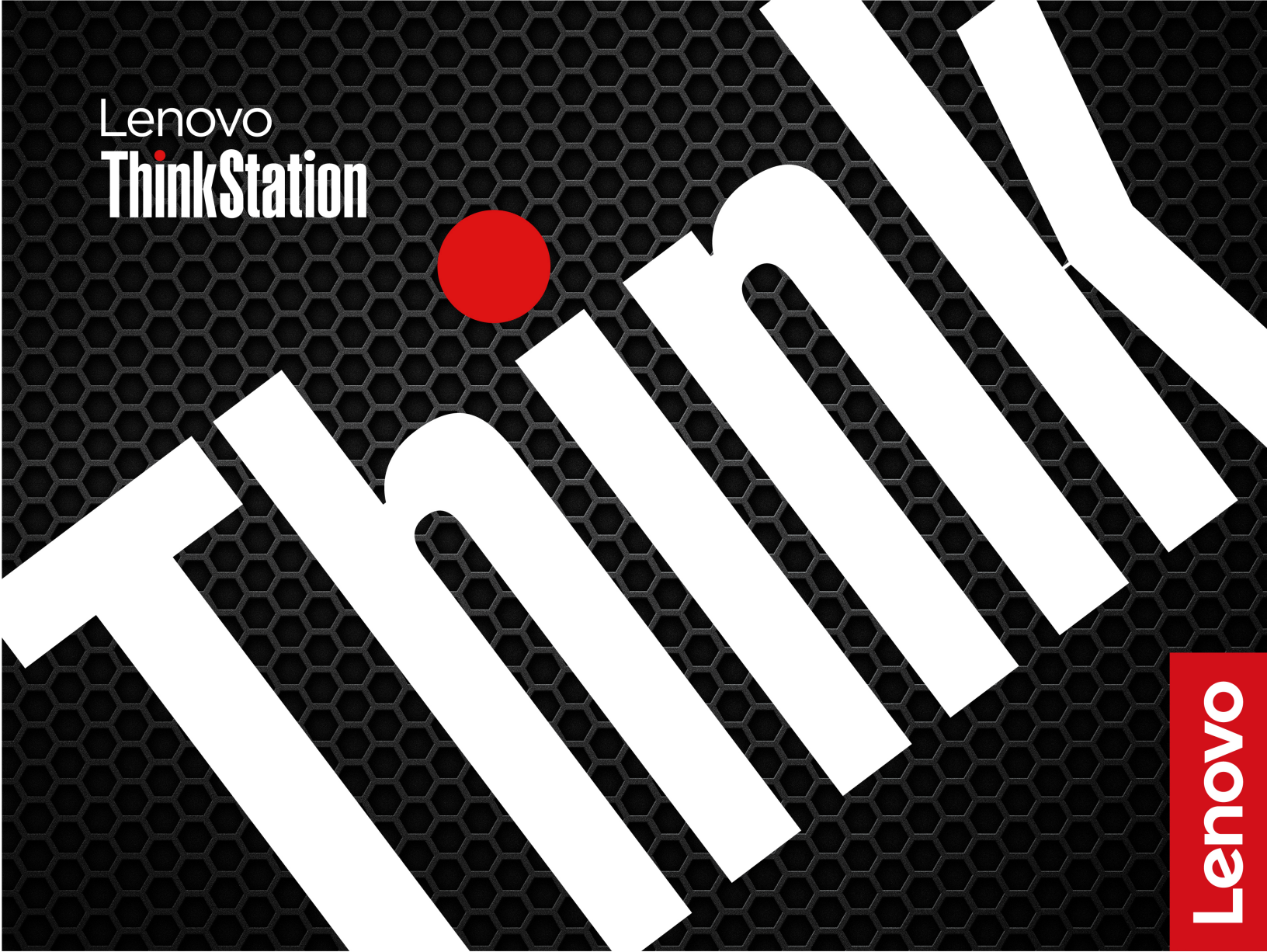

ThinkStation PX

Read this first

Before using this documentation and the product it supports, ensure that you read and understand the following:

- *Safety and Warranty Guide*
- *Generic Safety and Compliance Notices*
- *Setup Guide*

Seventh Edition (February 2026)

© Copyright Lenovo 2023, 2026.

LIMITED AND RESTRICTED RIGHTS NOTICE: If data or software is delivered pursuant to a General Services Administration "GSA" contract, use, reproduction, or disclosure is subject to restrictions set forth in Contract No. GS-35F-05925.

Contents

Discover your Lenovo computeriii

Chapter 1. Overview 1

Front	1
Left	3
Rear	5
Workplace power notice	6
Specifications	8
USB specifications	10

Chapter 2. Get started. 12

Connect an external display	12
Get started with Ubuntu Desktop (22.04 LTS)	12
Get started with Ubuntu Desktop (24.04 LTS)	12
Access networks in Ubuntu Desktop	13
Connect to the wired Ethernet	13
Connect to Wi-Fi networks (22.04 LTS) (for selected models)	13
Connect to Wi-Fi networks (24.04 LTS) (for selected models)	13
Transfer data	13
Connect to a Bluetooth-enabled device (22.04 LTS) (for selected models)	13
Connect to a Bluetooth-enabled device (24.04 LTS) (for selected models)	14
Set the power plan	15
Security solutions	15
Lock the computer	15
Use BIOS security solutions	16
UEFI BIOS passwords	18

Chapter 3. Explore your computer 20

Expand your computer	20
Memory slots	20
On-board M.2 SSD slots	21
PCIe slots	21
Front-access bays	22
PSU bays	22
UEFI BIOS	23
What is UEFI BIOS	23
Enter the BIOS menu	23
Navigate in the BIOS interface	23
Change the display language of UEFI BIOS	24
Change the display mode of UEFI BIOS (for selected models)	24
Set the system date and time.	24
Change the priority boot order	24

Enable or disable the configuration change detection feature	25
Enable or disable the automatic power-on feature	25
Change BIOS settings before installing a new operating system	26
Update UEFI BIOS	26
Reset system to factory default	26
View UEFI BIOS Event logs	27

Chapter 4. Hardware replacement 29

Before CRU replacement	29
What is CRU	29
CRU list	29
System board.	32
Prerequisites for hardware replacement	34
ThinkStation logo badge	35
ID badge	35
Dummy cover for the upper PSU bay	36
Power supply assembly.	37
Top cover	37
Wi-Fi antenna cover	38
Left side cover	39
Lock kit for the left side cover	41
Right side cover.	44
CPU duct	47
Blank bezel	47
Fans	48
Front fan assembly.	48
Front fan bracket	49
Rear fan assembly	50
Storage fan assembly.	51
Memory fan	51
Storage drives	52
HDD in the front access bay	52
HDD in the PSU bay storage enclosure	54
M.2 SSD in the front access bay	56
Dual M.2 SSD enclosure	58
Onboard M.2 SSD and its heatsink kit	59
M.2 SSD on an M.2 SSD PCIe adapter	62
PCIe cards.	65
NVLINK retainer	66
NVLINK bridge	66
Super capacitor module.	68
PCIe bracket	68
Half-length PCIe card.	69
Full-length PCIe card	71

PCIe card installation rule	73
Cable connection	74
Lock kit for the front access bay	78
Memory module	80
Front panel IO assembly	83
Think LED holder and cable	84
Power distribution board and bracket	85
BCB board and bracket.	86
Chapter 5. Help and support	88
Self-help resources	88
Lenovo diagnostic tools	88
Call Lenovo	88
Certification-related information	89

Compliance information	89
Purchase additional services.	90
Purchase accessories	90
Accessibility features.	90

Appendix A. Supplemental information about the Ubuntu operating system 91

Appendix B. Important notice for Quebec consumers 93

Appendix C. Notices and trademarks. 94

Discover your Lenovo computer

Thank you for choosing a Lenovo® computer! We are dedicated to delivering the best solution to you.

Before starting your tour, please read the following information:

- Illustrations in this documentation might look different from your product.
- Depending on the model, some optional accessories, features, software programs, and user interface instructions might not be applicable to your computer.
- Documentation content is subject to change without notice. Lenovo makes constant improvements to the documentation of your computer, including this *User Guide*. To get the latest documentation, go to:
 - For computers purchased in mainland China: <https://iknow.lenovo.com.cn>
 - For computers purchased outside mainland China: <https://support.lenovo.com/documentation>

Chapter 1. Overview

Front

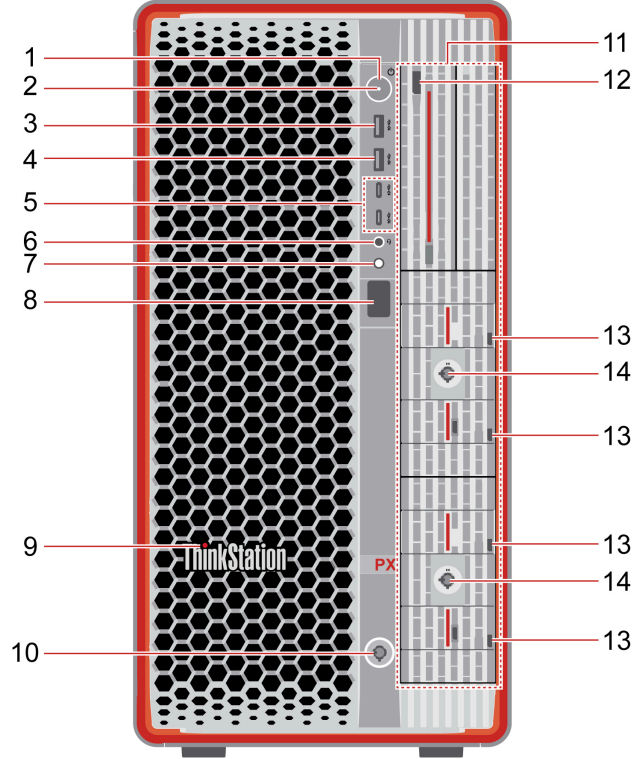

Item	Description	Item	Description
1.	Power button	2.	Power indicator
3.	USB-A 3.2 Gen 2 connector*	4.	Always On USB-A 3.2 Gen 2 connector*
5.	USB-C® (3.2 Gen 2) connectors*	6.	Headset connector
7.	Diagnostic LCD switch	8.	Diagnostic LCD
9.	ThinkStation®LED	10.	Front access bay lock
11.	Front access bays (1 to 6)	12.	HDD (hard disk drive) LED label*
13.	M.2 SSD (solid-state drive) LED labels*	14.	Dual M.2 SSD enclosure locks*

* for selected models

Statement on USB transfer rate

Depending on many factors such as the processing capability of the host and peripheral devices, file attributes, and other factors related to system configuration and operating environments, the actual transfer rate using the various USB connectors on this device will vary and will be slower than the data rate listed below for each corresponding device.

USB device	Data rate (Gbit/s)
3.2 Gen 1	5
3.2 Gen 2	10
3.2 Gen 2 × 2	20
Thunderbolt 3 (USB-C)	40
Thunderbolt 4 (USB-C)	40

Power indicator

Show the system status of your computer.

- **On:** The computer is starting up or working.
- **Off:** The computer is off or in hibernation mode.
- **Blinking slowly:** The computer is in sleep mode.

Always On USB-A 3.2 Gen 2 connector

With the Always On USB feature enabled, the Always On USB-A 3.2 Gen 2 connector can charge a USB-A compatible device when the computer is on, off, in sleep mode, or in hibernation mode.

To enable the Always On USB feature, do the following:

1. Enter the UEFI BIOS menu. See “Enter the BIOS menu” on page 23.
2. Click **Devices** → **USB Setup** → **Front USB Ports** → **USB Port 2** to enable the Always On USB feature.

Diagnostic LCD switch

Use the diagnostic LCD switch to turn on or turn off the diagnostic LCD, and handle occurred events.

Status	Behavior and function
No event	Short press: Turn on or turn off the diagnostic LCD. Date and time will be displayed on the LCD when it is turned on. The LCD will turn off automatically if idle for three minutes.
Error events occur	The diagnostic LCD will turn on automatically when an error event occurs. <ul style="list-style-type: none"> • Short press (when multiple events occur): Switch among error events and display the corresponding QR code of the selected event. • Long press (about 3 seconds): Clear the selected event.

The diagnostic LCD behavior can be changed in the UEFI BIOS as follows.



1. Turn on or restart the computer. When the logo screen is displayed, press F1 or Fn+F1 to enter the UEFI BIOS menu.
2. Go to **Advanced** → **Diagnostics**. Choose to show only the Diagnostic Error Code or both it and the BIOS POST Code. Adjust other settings if needed.

Diagnostic LCD

Display the diagnostic information when an issue or error is detected. You can decode the error code at <https://www.thinkworkstationsoftware.com/?view=codes>.

HDD or M.2 SSD LED label

The storage drives have the following two types of LEDs:

LED	Status and indication
 Status LED	<ul style="list-style-type: none"> • Solid on: The storage drive status is failure. • 4 Hz blinking (four times per second): Locating the storage drive. • 1 Hz blinking (once a second): Rebuilding RAID. • Off (when the computer is powered on): The storage drive status is normal.
 Activity LED	<ul style="list-style-type: none"> • Solid on: The storage drive is online, installed, or powered on (no activity). • Variable blinking: Accessing the storage drive. • Off (when the computer is powered on): The storage drive is not installed or powered.

Left

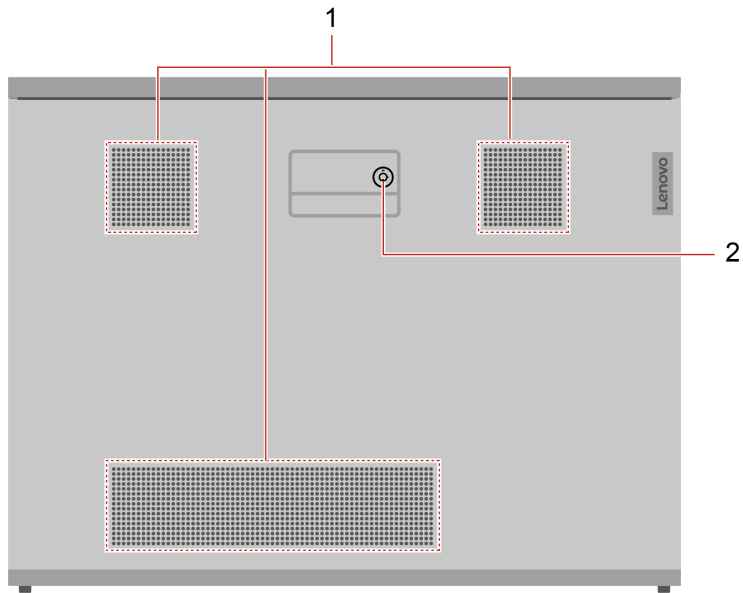

Item	Description	Item	Description
1	Side air vents*	2	Lock for side cover*

* for selected models

Side ventilation notice

Side ventilation design is available on some models. Pay attention to the ventilation distance requirements for models with different configurations:

- Systems configured with rear-exhausting graphics cards (such as NVIDIA RTX 6000 Ada) do not require side ventilation.
- Systems configured with internal-exhausting graphics cards (such as GeForce RTX 4070 and GeForce RTX 4080) require side ventilation. Do not block air vents on the left side cover. To ensure heat dissipation, do not place any objects within 4.5 cm (1.8 inches) or 1 rack unit from the left side cover.
- For rack-mounted systems, a rack spacer is recommended in the gap above the system.

Note: Do not install internal-exhausting graphics cards (such as GeForce RTX 4070 and GeForce RTX 4080) on systems without side ventilation on the left side cover.

Related topics

“Use physical locks” on page 15

Rear

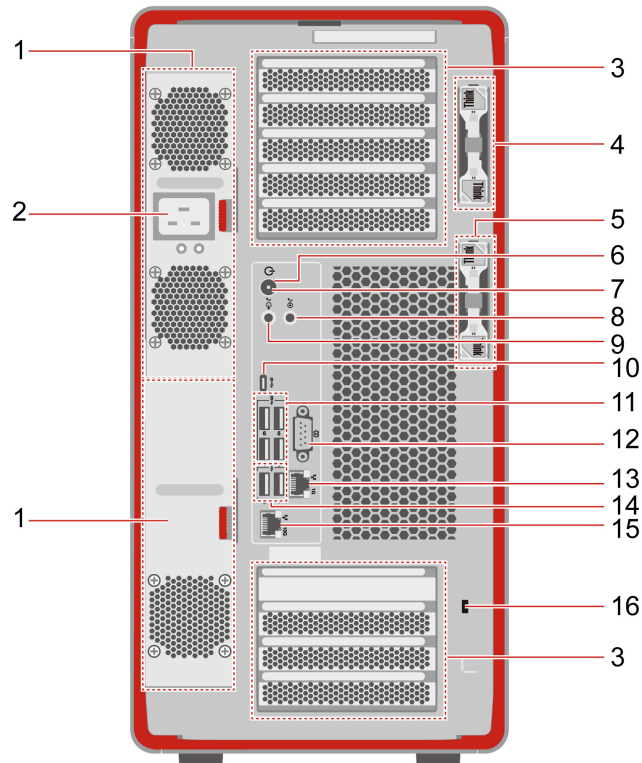

Item	Description	Item	Description
1.	Power supply unit bays (2)	2.	Power cord connector
3.	PCIe card areas	4.	Key-nest for the left side cover and front access bays
5.	Key-nest for the dual M.2 SSD enclosure	6.	Power button
7.	Power indicator	8.	Audio line-in connector
9.	Audio line-out connector	10.	USB-C (3.2 Gen 2x2) connector
11.	USB-A 3.2 Gen 1 connectors	12.	Serial connector*
13.	Ethernet connector (1 G)	14.	USB-A 2.0 connectors
15.	Ethernet connector (10 G)	16.	Security-lock slot

* for selected models

Power indicator

Show the system status of your computer.

- **On:** The computer is starting up or working.
- **Off:** The computer is off or in hibernation mode.
- **Blinking slowly:** The computer is in sleep mode.

Serial connector

Connect an external modem, a serial printer, or other devices that use a serial connector.

PCIe card areas

Install PCIe cards into these areas to improve the operating performance of the computer. Depending on the computer model, the video output connectors in these areas might be DisplayPort™ connectors or Mini DisplayPort™ connectors.

Workplace power notice



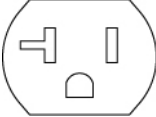
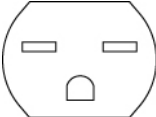
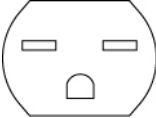

- Only use the power cord shipped with your computer.
- General power supply requirements:
 - Ensure that your workplace is able to support the AC outlet and AC current requirements.
 - Low AC voltage countries require up to 20 amps of AC power.
 - Japan and Taiwan region require a high AC voltage outlet.
 - See details in the table below for North America, Japan, and Taiwan region.

Low / High AC voltage	Countries or regions	Requirements
Low AC voltage	North America (110-127V AC typical)	<ul style="list-style-type: none">– Require 110-127V / 20A AC receptacle.– Lenovo power cord part number: SL60P41047  <p>125V / 20A</p>
Low AC voltage	Japan (100V AC typical)	<ul style="list-style-type: none">– Require 200V / 12A AC receptacle.– Lenovo power cord part number: SL60P41056  <p>250V / 15A</p>
Low AC voltage	Taiwan region (110V AC typical)	<ul style="list-style-type: none">– Require 220V / 12A AC receptacle.– Lenovo power cord part number: SL60P41049  <p>250V / 15A</p>
High AC voltage	Countries or regions except North America, Japan, and Taiwan region	<ul style="list-style-type: none">– Require 220-240V / 12A AC various receptacle.– Minimum 12A circuit per power supply

- Redundant mode hot-plug power supply requirements:
 - A dedicated circuit is recommended for each power supply to maximize redundancy.
 - System must be configured to the maximum output of single power supply. Upgrading system components may compromise redundancy.
- Teamed mode power supply requirements:
 - A dedicated circuit is required for each power supply for low AC voltage workplace and is recommended for high AC voltage workplace.
 - Teaming allows system power output up to 2350 W. Total output power is 100-240V / 27-12A AC.
 - Do not hot plug in teamed mode with system power consumption above single PSU maximum output power. This might result in immediate power off.

Specifications

Specifications	Description
Dimensions	<ul style="list-style-type: none">• Width: 220 mm (8.7 inches)• Height: 440.4 mm (17.3 inches, with feet)• Depth: 575 mm (22.6 inches)
Weight (without packaging)	Maximum configuration as shipped: 35.6 kg (78.5 lb)
Hardware configuration	<ul style="list-style-type: none">• For Ubuntu 22.04:<ol style="list-style-type: none">1. Open the system menu from the top-right corner and click Settings.2. Click About.• For Ubuntu 24.04:<ol style="list-style-type: none">1. Open the system menu from the top-right corner and click .2. Click System → About.
Power supply	<p>1850-watt 92% hot-swappable power supply, downgrade to 1400-watt (supported by firmware in some regions)</p> <p>Notes:</p> <ul style="list-style-type: none">• Only use the power cord shipped with the system and ensure that your workplace is able to support the AC outlet and AC current requirements.• A dedicated circuit is recommended for each power supply.• Pay attention to the hot swap using scenarios in case system power consumption above single PSU maximum output power. This might result in immediate power off.
Electrical input	<ul style="list-style-type: none">• Input voltage: From 100 V ac to 240 V ac• Input frequency: 50/60 Hz
Microprocessor	<ul style="list-style-type: none">• For Ubuntu 22.04:<p>To view the microprocessor information of your computer, enter Settings and click About.</p>• For Ubuntu 24.04:<p>To view the CPU information of your computer:</p><ol style="list-style-type: none">1. Open the system menu from the top-right corner and click .2. Click System → About.
Memory	<ul style="list-style-type: none">• Quantity:<ul style="list-style-type: none">– 1 CPU: 1, 2, 4, 6, or 8 memory modules– 2 CPUs: 2, 4, 8, 12, or 16 memory modules• Type:<ul style="list-style-type: none">– DDR5-4800 (double data rate 5 at 4800 MT/s) ECC (error correction code) RDIMM (registered dual inline memory modules)– DDR5-5600 ECC RDIMM <p>Note: See “System memory speed” on page 9 for memory speed statements.</p> <ul style="list-style-type: none">• Capacity: 16 GB, 32 GB, 64 GB, or 128 GB

Specifications	Description
Storage device	<ul style="list-style-type: none"> • 3.5-inch HDD* (hot-swappable in the front access bay) • 3.5-inch HDD* (in the PSU bay 2) • 2280 Gen 4 or Gen 5 M.2 SSD* (Onboard) • 2280 Gen 4 M.2 SSD* (hot-swappable in the front access bay) • 2280 Gen 4 or Gen 5 M.2 SSD* on an M.2 SSD PCIe adapter* <p>Type Disks in the search box and use the Disks application to view the storage drive capacity of your computer.</p> <p>Note: The storage drive capacity indicated by the system is less than the nominal capacity.</p>
Video features	<ul style="list-style-type: none"> • PCIe x16 card slots on the system board for a discrete graphics card • Video connectors on a discrete graphics card: <ul style="list-style-type: none"> – DisplayPort connector – Mini DisplayPort connector
Expansion	<ul style="list-style-type: none"> • Front access bay • Memory slots • M.2 SSD slots • PCIe slots • Power supply unit bay
Network features	<ul style="list-style-type: none"> • Bluetooth* • Ethernet LAN • Wireless LAN*

* for selected models

Note: You can enhance your computer capacity and performance by adding various devices according to the rules listed in “Expand your computer” on page 20

System memory speed

Your computer can come with the following types of memory modules and will run up to the following speed:

Memory module type	Memory module speed
DDR5–4800 ECC RDIMM	4800 MT/s
DDR5–5600 ECC RDIMM	5600 MT/s

To avoid unexpected frequency reduction, ensure that you install memory modules in a right way:

- Installed memory module quantity:
 - 1 CPU: 1, 2, 4, 6, or 8 memory modules
 - 2 CPUs: 2, 4, 8, 12, or 16 memory modules
- Install memory modules of the same type, the same capacity, and the same DRAM densities.
- Install memory modules in the correct order. See “Memory module” on page 80.

Notes:

- The actual system memory speed of the memory modules depends on the microprocessor model. For example, your computer comes with 4800 MT/s memory modules, but the microprocessor only supports up to 4400 MT/s memory modules. Then the system memory speed will be no faster than 4400 MT/s. For microprocessor models supported in your computer, contact the Lenovo Customer Support Center.
- If you install memory modules of different speed, the actual system memory speed will be set to the lowest speed of all the memory modules.

Operating environment**Maximum altitude (without pressurization)**

- Operating: From 0 m (0 ft) to 3048 m (10 000 ft)
- Storage: From 0 m (0 ft) to 12192 m (40 000 ft)

Temperature

- Operating: From 10°C (50°F) to 35°C (95°F)
- Storage: From -40°C (-40°F) to 60°C (140°F)

Relative humidity

- Operating: 20%-80% (non-condensing)
- Storage: 10%-90% (non-condensing)



USB specifications

Note: Depending on the model, some USB connectors might not be available on your computer.

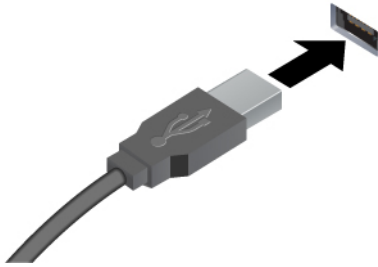
Connector name	Description
----------------	-------------



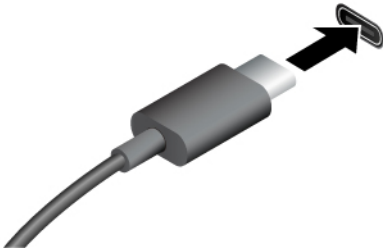

Connect USB-A compatible devices, such as a USB-A keyboard, USB-A mouse, USB-A storage device, or USB-A printer.

-  USB-A 2.0 connector
-  USB-A 3.2 Gen 1 connector
-  USB-A 3.2 Gen 2 connector



- Charge USB-C compatible devices with the output voltage and current of 5 V and 3 A.
- Connect to USB-C accessories to help expand your computer functionality. To purchase USB-C accessories, go to <https://www.lenovo.com/accessories>.

-  USB-C (3.2 Gen 2) connector
-  USB-C (3.2 Gen 2x2) connector

Chapter 2. Get started

Connect an external display

1. Right-click a blank area on the desktop and select display settings.
 2. Select the display that you want to configure and change display settings of your preference.
-

Get started with Ubuntu Desktop (22.04 LTS)

Learn the basics of Ubuntu and start working with it right away. For more information about Ubuntu, see the Ubuntu documentation site at: <https://help.ubuntu.com/lts/ubuntu-help/index.html>.

The Gnome desktop is installed by default and is designed to be simple and easy to use. Details on using Gnome are available by launching the Help application or online at <https://help.gnome.org/users/>.

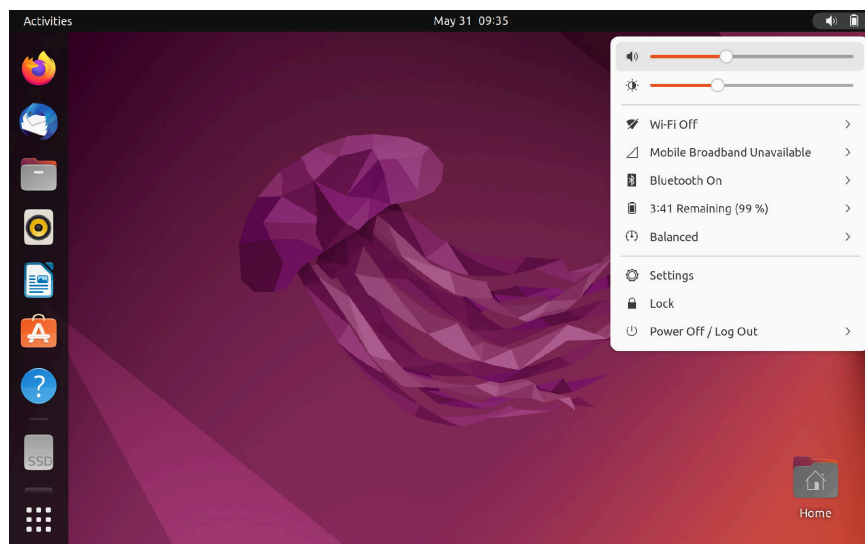

Launch an app

- Press the Super key (with the Windows logo) or open the Activities menu on the top left and type in the name of the application you want to launch.
- Click the **Show Applications** button on the lower left, and select the application you want to launch.

Launch settings

Open the system menu from the top-right corner and click **Settings**.

Get started with Ubuntu Desktop (24.04 LTS)

Learn the basics of Ubuntu and start working with it right away. For more information about Ubuntu, see the Ubuntu documentation site at: <https://help.ubuntu.com/lts/ubuntu-help/index.html>.

The Gnome desktop is installed by default and is designed to be simple and easy to use. Details on using Gnome are available by launching the Help application or online at <https://help.gnome.org/users/>.

Launch an app

- Press the Super key (with the Windows logo) or open the Activities menu on the top left and type in the name of the application you want to launch.
- Click the **Show Apps** button on the lower left, and select the application you want to launch.

Launch settings

Open the system menu from the top-right corner and click .

Access networks in Ubuntu Desktop

This section helps you access networks through connecting to a wired or wireless network.

Connect to the wired Ethernet

Connect your computer to a local network through the Ethernet connector on your computer with an Ethernet cable.

Connect to Wi-Fi networks (22.04 LTS) (for selected models)

If your computer includes a wireless LAN module, you can connect your computer to Wi-Fi® networks.

1. Open the system menu from the top-right corner and expand the Wi-Fi section of the menu.
2. Click **Select Network**. A list of available wireless networks is displayed.
3. Select a network available for connection. Provide required information, if needed.

Connect to Wi-Fi networks (24.04 LTS) (for selected models)

If your computer includes a wireless LAN module, you can connect your computer to Wi-Fi® networks.

1. Open the system menu from the top-right corner and turn on the Wi-Fi by clicking **Wi-Fi** button.
2. Click **>** to expand the Wi-Fi section of the menu. A list of available wireless networks is displayed. Click **All Networks** to see extra options.
3. Select an available network for connection. Provide required information if needed.

Transfer data

Quickly share your files using the built-in Bluetooth technology among devices with the same features. You also can install a disc or media card to transfer data.

Connect to a Bluetooth-enabled device (22.04 LTS) (for selected models)

You can connect all types of Bluetooth-enabled devices to your computer, such as a keyboard, a mouse, a smartphone, or speakers. Place the device that you are attempting to connect to less than 10 meters (33 feet) from the computer.

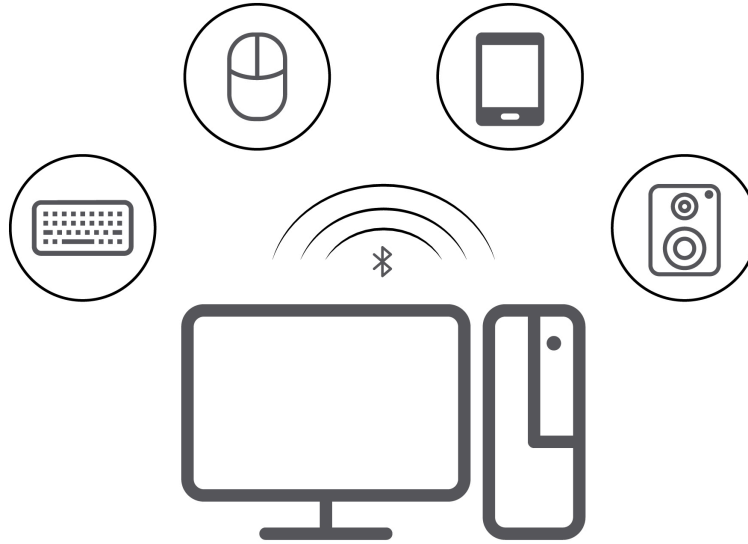

1. Turn on Bluetooth on the computer.
 - a. Open the system menu from the top-right corner and then click **Settings** → **Bluetooth**.
 - b. In the Bluetooth section enable Bluetooth with the toggle button at the top.
2. Any discoverable devices will be shown in the **Devices** list.
3. Select a Bluetooth device, and then follow the on-screen instructions.

Connect to a Bluetooth-enabled device (24.04 LTS) (for selected models)

You can connect all types of Bluetooth-enabled devices to your computer, such as a keyboard, a mouse, a smartphone, or speakers. Place the device that you are attempting to connect to less than 10 meters (33 feet) from the computer.



1. Open the system menu from the top-right corner and turn on the Bluetooth by clicking **Bluetooth** button.
2. Click > to expand the Bluetooth section of the menu. A list of discoverable devices is displayed.

3. Select a Bluetooth device, and then follow the on-screen instructions.

Your Bluetooth-enabled device and computer will automatically connect the next time if the two devices are in range of each other with Bluetooth turned on. You can use Bluetooth for data transfer or remote control and communication.

Set the power plan

For ENERGY STAR® compliant computers, the following power plan takes effect when your computers have been idle for a specified duration:

- Turn off the display: After 5 minutes
- Put the computer to sleep: After 20 minutes

To awaken the computer from Sleep mode, press any key on your keyboard.

To set the power plan:

1. Go to **Settings → Power**.
2. Choose or customize a power plan of your preference.

Security solutions

Lenovo values your information security. Your computer can be secured by physical locks, software solutions, and BIOS solutions. They can protect your computer from harm, theft, or unauthorized use.

Lock the computer

Note: Lenovo makes no comments, judgments, or warranties about the function, quality, or performance of the locking device and security feature. You can purchase computer locks from Lenovo.

Key lock

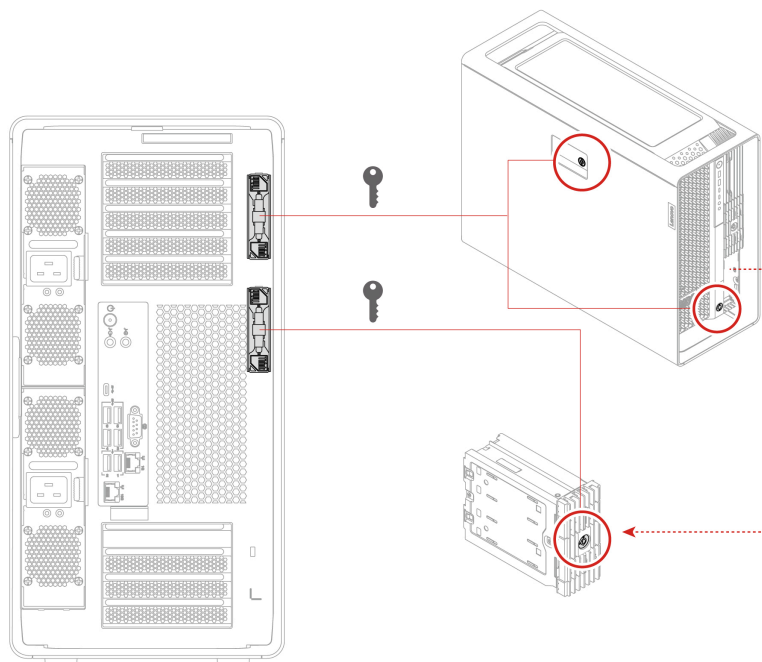

- Locks
 - Locks for side cover, front access bay, and dual M.2 SSD enclosure prevent unauthorized access to the inside of your computer chassis or storage drives.
 - The storage drive in the front access bay can be hot-swappable, which means that you can install or replace the drive without even turning off your computer. Therefore, lock the front access bay to prevent unexpected removal.
- Keys
 - The keys are attached to the rear of the machine. For security, store the keys in a secure place when you are not using them.
 - The keys can be carved with numbers, for example, **00**, **01**, **02**, and **03**. The key can unlock locks that are carved with the same number on the same computer or on other computers.

Security lock

Lock your computer to a desk, table, or other fixtures through a security lock.

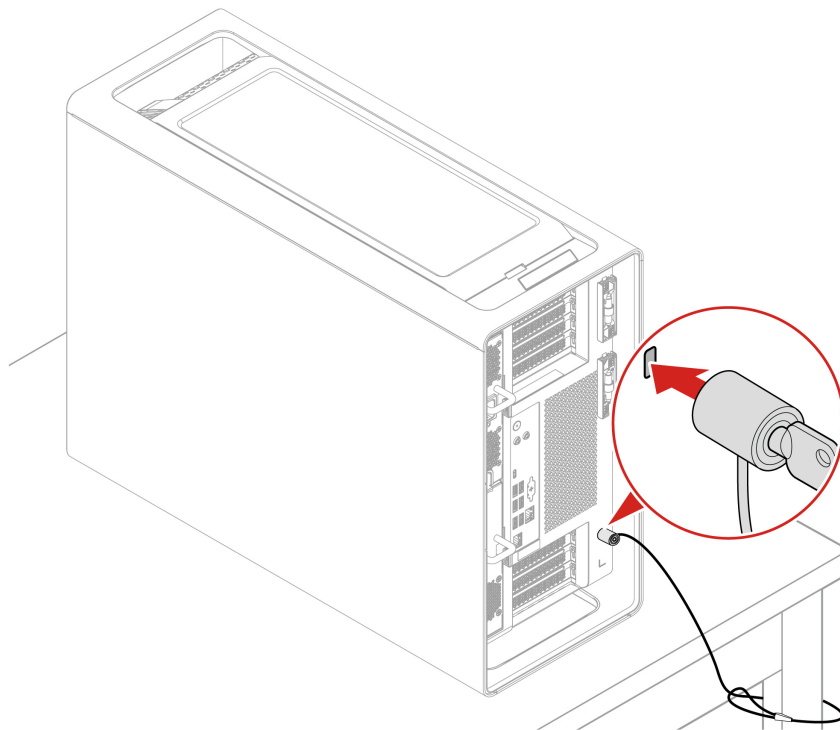

Use BIOS security solutions

This section provides BIOS solutions to secure your computer and information.

Wipe the storage drive data

It is recommended that you wipe the storage drive data before recycling the storage drive or the computer.

To wipe the storage drive data:

1. Restart the computer. When the logo screen is displayed, press F1 or Fn+F1.
2. Select **Security** → **secure wipe** → **Enabled**.
3. Press F10 or Fn+F10 to save the changes and exit.

4. Restart the computer. When the logo screen is displayed, press F12 or Fn+F12.
5. Select **App Menu** → **secure wipe** and press Enter.
6. Select the storage drive you will wipe and click **NEXT**.
7. Select the entire storage drive or partition to wipe as desired.
8. Select the method as desired and click **NEXT**.
9. Click **Yes** to confirm your option when the prompting window is displayed.
10. If you have set a hard disk password for the storage drive, enter the password. Otherwise, set a temporary password following the on-screen instructions. Then, click **NEXT**. The wiping process begins.

Note: Duration of the wiping process varies depending on the storage drive capacity.

11. Click **Reboot** when you are prompted to reset the system, and then one of the following will happen:
 - If the system storage drive data is wiped, you will be prompted that no operating system is found.
 - If the non-system storage drive data is wiped, the computer restarts automatically.

Cover presence switch

The cover presence switch prevents the computer from logging in to the operating system when the computer cover is not properly installed or closed.

To enable or disable the cover presence switch on the system board:

1. Restart the computer. When the logo screen is displayed, press F1 or Fn+F1.
2. Select **Security** → **Cover Tamper Detected** and press Enter.
3. Select **Enabled** or **Disabled** and press Enter.
4. Press F10 or Fn+F10 to save the changes and exit.

If the cover presence switch is enabled and the computer cover is not correctly installed or closed, an error message will be displayed when you turn on the computer. To bypass the error message and log in to the operating system:

1. Properly install or close the computer cover.
2. Enter the BIOS menu, save and then exit.

Intel BIOS guard

The Intel® BIOS Guard module cryptographically verifies all BIOS updates. This hardware-based security helps prevent software and malware attacks on the computers BIOS.

Smart USB Protection

The Smart USB Protection function is a security function that helps prevent data from being copied from the computer to USB storage devices connected to the computer. You can set the Smart USB Protection function to one of the following modes:

- **Disabled** (default setting): You can use the USB storage devices without limitation.
- **Read Only:** You cannot copy data from the computer to the USB storage devices. However, you can access data on the USB storage devices.
- **No Access:** You cannot access the USB storage devices from the computer.

To configure the Smart USB Protection function:

1. Restart the computer. When the logo screen is displayed, press F1 or Fn+F1.
2. Select **Security** → **Smart USB Protection** and press Enter.

3. Select the desired setting and press Enter.
4. Press F10 or Fn+F10 to save the changes and exit.

Absolute Persistence (for computers purchased outside mainland China)

Absolute Persistence technology is embedded in BIOS. It detects changes that happen on the hardware, software, or the call-in location. It keeps you always knowing what condition the computer is in. To activate the technology, you have to purchase a subscription to Absolute.

UEFI BIOS passwords

You can set passwords in UEFI (Unified Extensible Firmware Interface) BIOS (Basic Input/Output System) to strengthen the security of your computer.

Password types

You can set a power-on password, supervisor password, system management password, or hard disk password in UEFI BIOS to prevent unauthorized access to your computer. However, you are not prompted to enter any UEFI BIOS password when your computer resumes from sleep mode.

- Power-on password

When a power-on password is set, you are prompted to enter a valid password each time the computer is turned on.

- Supervisor password

Setting a supervisor password deters unauthorized users from changing configuration settings. If you are responsible for maintaining the configuration settings of several computers, you might want to set a supervisor password.

When a supervisor password is set, you are prompted to enter a valid password each time you try to enter the BIOS menu.

If both the power-on password and supervisor password are set, you can enter either password. However, you must use your supervisor password to change any configuration settings.

- Hard disk password (for selected models)

Setting a hard disk password prevents unauthorized access to the data on the storage drive. When a hard disk password is set, you are prompted to enter a valid password each time you try to access the storage drive.

Note: After you set a hard disk password, your data on the storage drive is protected even if the storage drive is removed from one computer and installed in another.

- System management password (for selected models)

You can enable the system management password to have the same authority as the supervisor password to control security related features. To customize the authority of the system management password through the UEFI BIOS menu:

1. Restart the computer. When the logo screen is displayed, press F1 or Fn+F1.
2. Select **Security → System Management Password Access Control**.
3. Follow the on-screen instructions.

If you have set both the supervisor password and the system management password, the supervisor password overrides the system management password.

Set, change, and remove a password

Before you start, print these instructions.

1. Restart the computer. When the logo screen is displayed, press F1 or Fn+F1.

2. Select **Security**.
3. Depending on the password type, select **Set Supervisor Password**, **Set Power-On Password**, **Set System Management Password**, or **Hard Disk Password** and press Enter.
4. Follow the on-screen instructions to set, change, or remove a password.
5. Press F10 or Fn+F10 to save the changes and exit.

You should record your passwords and store them in a safe place. If you forget the passwords, contact a Lenovo-authorized service provider.

Note: If the hard disk password is forgotten, Lenovo cannot remove the password or recover data from the storage drive.

Chapter 3. Explore your computer

Expand your computer

You can enhance your computer capacity and performance by adding various devices into the following slots or bays. To add or replace a device, see Chapter 4 “Hardware replacement” on page 29 for replacement instructions.

Memory slots

Your computer has sixteen memory slots. You can expand the configurations according to the rules listed in the following table.

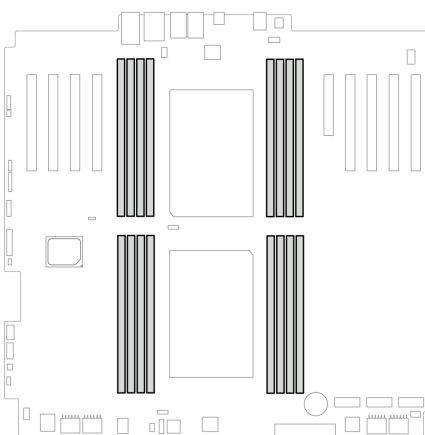

Items	Rules
Quantity	<ul style="list-style-type: none">• 1 CPU: 1, 2, 4, 6, or 8 memory modules• 2 CPUs: 2, 4, 8, 12, or 16 memory modules
Type	<ul style="list-style-type: none">• DDR5-4800 ECC RDIMM• DDR5-5600 ECC RDIMM <p>Note: See “System memory speed” on page 9 for memory speed statements.</p>
Capacity	16 GB, 32 GB, 64 GB, 128 GB, or 256 GB
Others	<ul style="list-style-type: none">• Install memory modules of the same type, the same capacity, and the same DRAM densities.• Install memory modules in the correct order. See “Memory module” on page 80.

Memory fan

Your computer has at least one memory fan. If you install any of the following memory modules, two memory fans are required.

- 128 GB or 256 GB DDR5-4800 ECC RDIMM
- 64 GB, 128 GB, or 256 GB DDR5-5600 ECC RDIMM

On-board M.2 SSD slots

Your computer has three on-board M.2 SSD slots. You can expand the configurations according to the following rules.

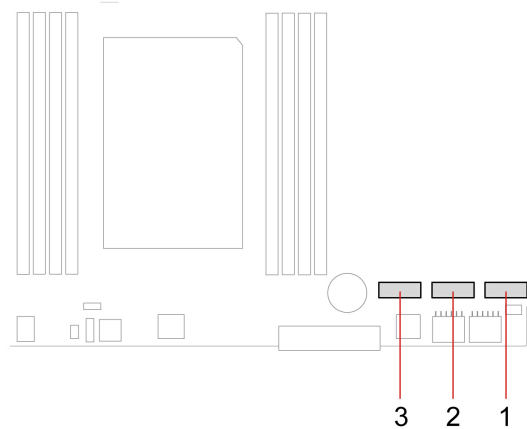

Installation order

Installation order	Slot
1	slot 1
2	slot 2
3	slot 3

Supported M.2 SSD type

Slot	Supported M.2 SSD type
Slot 1, slot 2	<ul style="list-style-type: none">• 2280 or 22110 Gen 4 M.2 SSD• 2280 or 22110 Gen 5 M.2 SSD
Slot 3	<ul style="list-style-type: none">• 2280 Gen 4 M.2 SSD• 2280 Gen 5 M.2 SSD

Note: For better performance, it's recommended that you install on-board M.2 SSD of the same generation.

Power of Gen 5 M.2 SSD

Slot	Power of Gen 5 M.2 SSD
Slot 1, slot 2	<ul style="list-style-type: none">• 10 W (when slot 3 is empty)• 8 W (when slot 3 is installed with Gen 5 M.2 SSD)
Slot 3	8 W

PCIe slots

Your computer has nine PCIe slots to install PCIe cards such as graphics card, BMC card, and different kinds of PCIe adapter card. For PCIe card installation order and special installation rules for certain PCIe cards, see “PCIe card installation rule” on page 73.

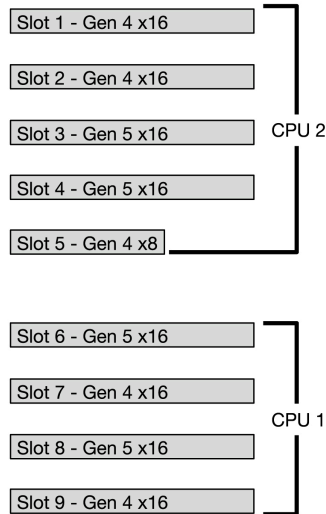

Front-access bays

Your computer has six front-access bays. The configuration of storage drive devices in the bays should follow the rules as shown below.

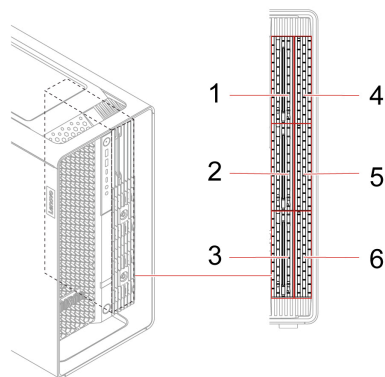

Option	Dual M.2 SSD enclosure	3.5-inch HDD (hot-swappable) in HDD bracket
1	Zero	Up to three (in bay 1 to 3)
2	One (in bay 2+5)	Up to two (in bay 1 and 3)
3	Two (in bay 2+5 and 3+6)	Up to one (in bay 1)

Note: Each dual M.2 SSD enclosure supports up to two Gen 4 M.2 SSDs (hot-swappable).

PSU bays

Your computer has two PSU bays. The configuration of devices in the bays should follow the rules as shown below.

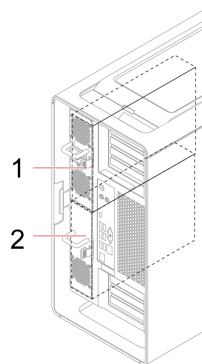

Option	Bay 1	Bay 2
1	Empty	One PSU
2	One PSU	One PSU
3	One PSU	One 3.5-inch HDD in a PSU bay storage enclosure

UEFI BIOS

What is UEFI BIOS

Note: The operating system settings might override any similar settings in UEFI BIOS.

UEFI BIOS is the first program that the computer runs when the computer is turned on. UEFI BIOS initializes the hardware components and loads the operating system and other programs. Your computer comes with a setup program with which you can change UEFI BIOS settings.

Enter the BIOS menu

Restart the computer. When the logo screen is displayed, press F1 or Fn+F1 to enter the BIOS menu.

Note: If you have set BIOS passwords, enter the correct passwords when prompted. You also can select **No** or press Esc to skip the password prompt and enter the BIOS menu. However, you cannot change the system configurations that are protected by passwords.

Navigate in the BIOS interface

Attention: The default configurations are already optimized for you in **boldface**. Improper change of the configurations might cause unexpected results.

Depending on your keyboard, you can navigate in the BIOS interface by pressing the following keys, or combinations of Fn and the following keys:

Key	Function
F1 or Fn+F1	General Help
Esc or Fn+Esc	Exit the submenu
↑ ↓ or Fn+↑ ↓	Locate an item

Key	Function
← → or Fn+← →	Move keyboard focus
+/- or Fn++/-	Change value
Enter	Enter the submenu
F9 or Fn+F9	Setup Defaults
F10 or Fn+F10	Save and exit

Change the display language of UEFI BIOS

UEFI BIOS supports three or four display languages: English, French, simplified Chinese, and Russian (for selected models).

To change the display language of UEFI BIOS:

1. Select **Main → Language** and press Enter.
2. Set the display language as desired.

Change the display mode of UEFI BIOS (for selected models)

You can use UEFI BIOS in the graphic mode or the text mode according to your needs.

The keys on the keyboard used to perform various tasks are displayed at the bottom of the screen. In addition to the keyboard, you also can use the mouse to make selections.

To change the display mode of UEFI BIOS:

1. Restart the computer. When the logo screen is displayed, press F1 or Fn+F1.
2. Select **Main → Setup Mode Select** and press Enter.
3. Set the display mode as desired.

Set the system date and time

1. Restart the computer. When the logo screen is displayed, press F1 or Fn+F1.
2. Select **Main → System Time & Date** and press Enter.
3. Set the system date and time as desired.
4. Press F10 or Fn+F10 to save the changes and exit.

Change the priority boot order

If the computer does not boot from a device as expected, you can change the boot priority order permanently or select a temporary boot device.

Change the priority boot order permanently

1. Depending on the type of the storage device, do one of the following:
 - If the storage device is internal, go to step 2.
 - If the storage device is a disc, ensure that the computer is on or turn on the computer. Then, insert the disc into the optical drive.
 - If the storage device is an external device other than a disc, connect the storage device to the computer.
2. Restart the computer. When the logo screen is displayed, press F1 or Fn+F1.

3. Select **Startup → Priority Boot Order**, and then follow the on-screen instructions to change the boot priority order.
4. You can also select the first priority device group by selecting **Startup → First Boot Device**, and then follow the on-screen instructions to select the first boot device within this group. Your computer will boot from the first boot device before trying the boot priority order you set in the previous step.
5. Press F10 or Fn+F10 to save the changes and exit.

Select a temporary boot device

Note: Not all discs and storage drives are bootable.

1. Depending on the type of the storage device, do one of the following:
 - If the storage device is internal, go to step 2.
 - If the storage device is a disc, ensure that the computer is on or turn on the computer. Then, insert the disc into the optical drive.
 - If the storage device is an external device other than a disc, connect the storage device to the computer.
2. Restart the computer. When the logo screen is displayed, press F12 or Fn+F12.
3. Select the storage device as desired and press Enter.

If you want to change the boot priority order permanently, select **Enter Setup** on Startup Device Menu and press Enter to enter the BIOS menu.

Enable or disable the configuration change detection feature

If you enable configuration change detection, when the POST detects configuration changes of some hardware devices (such as storage drives or memory modules), an error message will be displayed when you turn on the computer.

To enable or disable the configuration change detection feature:

1. Restart the computer. When the logo screen is displayed, press F1 or Fn+F1.
2. Select **Security → Configuration Change Detection** and press Enter.
3. Enable or disable the feature as desired.
4. Press F10 or Fn+F10 to save the changes and exit.

To bypass the error message and log in to the operating system, press F2 or Fn+F2. To clear the error message, enter the BIOS menu, save and then exit.

Enable or disable the automatic power-on feature

The Automatic Power On item in UEFI BIOS provides various options for you to make your computer start up automatically.

To enable or disable the automatic power-on feature:

1. Restart the computer. When the logo screen is displayed, press F1 or Fn+F1.
2. Select **Power → Automatic Power On** and press Enter.
3. Select the feature as desired and press Enter.
4. Enable or disable the feature as desired.
5. Press F10 or Fn+F10 to save the changes and exit.

Change BIOS settings before installing a new operating system

BIOS settings vary by operating system. Change the BIOS settings before installing a new operating system.

To change the BIOS settings:

1. Restart the computer. When the logo screen is displayed, press F1 or Fn+F1.
2. From the main interface, select **Security** → **Secure Boot** and press Enter.
3. Depending on the operating system to be installed, do one of the following:
 - To install the Windows 10 (64-bit) and most of Linux operating system, select **Enabled** for **Secure Boot**.
 - To install an operating system that does not support secure boot, select **Disabled** for **Secure Boot**.
4. Press F10 or Fn+F10 to save the changes and exit.

Update UEFI BIOS

When you install a new program, device driver, or hardware component, you might need to update UEFI BIOS. You can update the BIOS from your operating system or a flash update disc (supported only on selected models).

Download and install the latest UEFI BIOS update package by one of the following methods:

- Using the built-in software update service:
 - For Ubuntu operating system, Ubuntu software update will check the LVFS site for any firmware updates and notify you when updates are available.
 - For IGEL operating system (for selected models), update, downgrade, or reinstall the UEFI BIOS using the IGEL Universal Management Suite (UMS). See [Universal Firmware Update in the IGEL UMS](#).
- From the Lenovo Support Web site:
 1. Go to <https://pcsupport.lenovo.com>.
 2. Download the flash BIOS update driver for the operating system version or the ISO image version (used to create a flash update disc). Then, download the installation instructions for the flash BIOS update driver you have downloaded.
 3. Print the installation instructions and follow the instructions to update the BIOS.

Reset system to factory default

This feature allows you to reset the UEFI BIOS to the factory default settings, including all UEFI BIOS settings and internal data. It helps you wipe user data in case that you want to dispose of or reuse your computer.

1. Restart the computer. When the logo screen is displayed, press F1 to enter the UEFI BIOS menu.
2. Select **Security** → **Reset system to Factory Default** and press Enter.
3. Several warning windows might be displayed. Do the following before resetting the system to the factory default settings:
 - a. Deactivate the Absolute Persistence Module.
 - b. Remove the NVMe password if you have set one.
4. For computer models with RAID settings, a window is displayed to remind you of data damage. Select **Yes** to proceed.
5. A window is displayed to confirm all UEFI BIOS settings will be reset. Select **Yes** to proceed.

Note: If the **Intel AMT control** and **Absolute Persistence(R) Module** are permanently disabled, these settings cannot be reset successfully.

6. Enter the supervisor password, system management password or power-on password in the window prompted.

Your computer will restart immediately. It takes a few minutes to complete the initialization process. Your computer screen might be blank during this process. This is normal and you should not interrupt it.

View UEFI BIOS Event logs

The UEFI BIOS Event log viewer provides the brief information about UEFI BIOS events. Do the following to view the logs:

1. Restart the computer. When the logo screen is displayed, press F1.
2. Select **Main → BIOS Event log**. Then, press Enter. The UEFI BIOS Event log interface is displayed.
3. Navigate the interface by pressing the following keys, and then check details by selecting each item.
 - ↑ ↓: Move keyboard focus
 - PgUp / PgDn: Scroll page
 - Enter: Select
 - F3: Exit

The following UEFI BIOS event logs might be listed on your screen depending on UEFI BIOS activities. Each log consists of a date, a time, and a description of the event.

- **Power On** event: This log shows the Power On Self Test (POST) routine has started with the power-on process. It includes the power-on reason, the boot mode, and the shutdown reason.
- **Subcomponent Code Measurement** event: This log shows the subcomponent code measurement has worked. It includes the validation result of each component.
- **System Preboot Authentication** event: This log shows what credential is provided to gain preboot authentication. It includes the installed password, the password type, the input device, and the authentication result.
- **BIOS Password Change** event: This log shows the change history of the UEFI BIOS passwords. It includes the password type, the type and result of the event.
- **Subcomponent Self-healing** event: This log shows the information about the subcomponent where the recovery event occurred. It includes the cause and result of the event, and the recovered firmware version.
- **BIOS Setup Configuration Change** event: This log shows the change history of the UEFI BIOS Setup configuration. It includes the item name and value.
- **Device Change** event: This log shows the change history of devices. It includes the cause and type of the event.
- **System Boot** event: This log shows which device was utilized to boot the system. It includes the boot option, the description, and the file path list.
- **System Tamper** event: This log shows the occurrence of system tamper events. It includes the cause and type of the event.
- **POST Error** event: This log shows the occurrence of errors during the POST routine. It includes the error code.
- **Flash Update** event: This log shows the occurrence of flash update. It includes the cause and result of the event, and the updated firmware version.
- **Capsule Update** event: This log shows the occurrence of UEFI capsule firmware update. It includes the cause and result of the event, and the updated firmware version.
- **Log Cleared** event: This log shows UEFI BIOS event logs are cleared. It includes the cause and result of the event.

- **Shutdown / Reboot** event: This log shows the UEFI BIOS is successfully shut down or the system is rebooted. It includes the cause and type of the event.

Chapter 4. Hardware replacement

This chapter provides instructions on how to remove and install hardware for your computer.

Before CRU replacement

Before replacing hardware of your computer, read this section first. You will get to know what is CRU, the CRU list, system board connectors, and prerequisites for CRU replacement.

What is CRU

Customer Replaceable Units (CRUs) are parts that can be replaced by the customer. Lenovo computers contain the following types of CRUs:

- **Self-service CRUs:** Refer to parts that can be replaced easily by customer themselves or by trained service technicians at an additional cost.
- **Optional-service CRUs:** Refer to parts that can be replaced by customers with a greater skill level. Trained service technicians can also provide service to replace the parts under the type of warranty designated for the customer's machine.

If you intend on installing the CRU, Lenovo will ship the CRU to you. CRU information and replacement instructions are shipped with your product and are available from Lenovo at any time upon request. You might be required to return the defective part that is replaced by the CRU. When return is required: (1) return instructions, a prepaid shipping label, and a container will be included with the replacement CRU; and (2) you might be charged for the replacement CRU if Lenovo does not receive the defective CRU within thirty (30) days of your receipt of the replacement CRU. For full details, see the Lenovo Limited Warranty documentation at:

https://www.lenovo.com/warranty/llw_02

CRU list

The following is the CRU list of your computer.

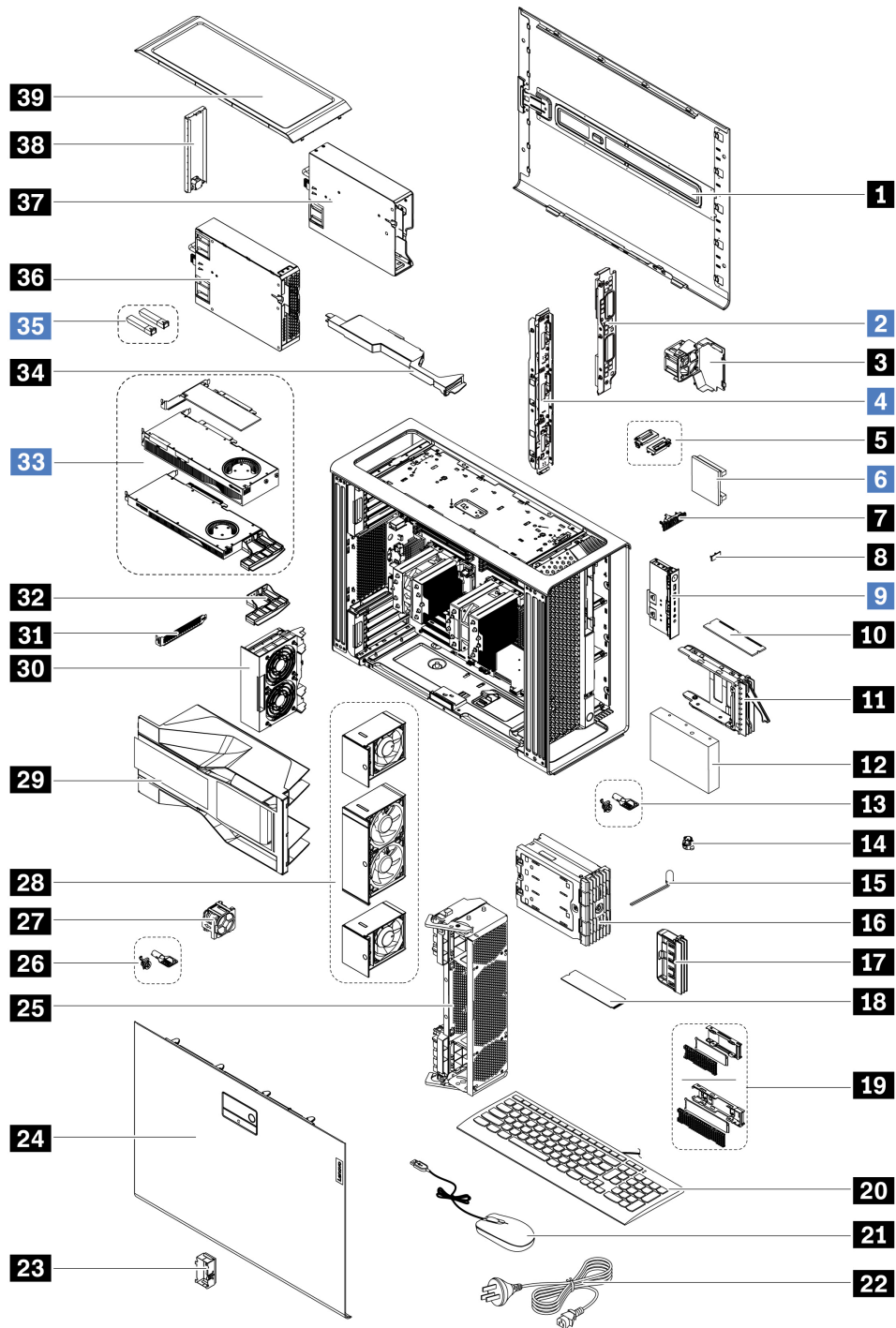

Number	Description	Self-service CRU	Optional-service CRU
1	Right side cover	Yes	
2	Power distribution board and bracket		Yes
3	Storage fan assembly	Yes	
4	BCB board and bracket		Yes
5	Wi-Fi antenna cover	Yes	

Number	Description	Self-service CRU	Optional-service CRU
6	NVLINK bridge*		Yes
7	ThinkStation logo badge	Yes	
8	ID badge	Yes	
9	Front panel IO assembly		Yes
10	Memory module	Yes	
11	HDD bracket*	Yes	
12	HDD*	Yes	
13	Lock kit for the front access bay*	Yes	
14	Think LED holder	Yes	
15	Think LED cable	Yes	
16	Dual M.2 SSD enclosure*	Yes	
17	Blank bezel	Yes	
18	M.2 SSD*	Yes	
19	On board M.2 SSD heatsink kit	Yes	
20	Keyboard	Yes	
21	Mouse	Yes	
22	Power cord	Yes	
23	NVLINK retainer*	Yes	
24	Left side cover	Yes	
25	Front fan bracket	Yes	
26	Lock kit for the left side cover*	Yes	
27	Memory fan	Yes	
28	Front fan assembly	Yes	
29	CPU duct	Yes	
30	Rear fan assembly	Yes	
31	PCIe bracket	Yes	
32	Customized PCIe extender*	Yes	
33	PCIe card		Yes
34	Super capacitor module*	Yes	
35	Ethernet-adapter-card fiber modules		Yes
36	Power supply assembly	Yes	
37	PSU bay storage enclosure	Yes	
38	Dummy cover for the upper PSU bay	Yes	
39	Top cover	Yes	

* for selected models

System board

Note: The system board might look slightly different from the illustration.

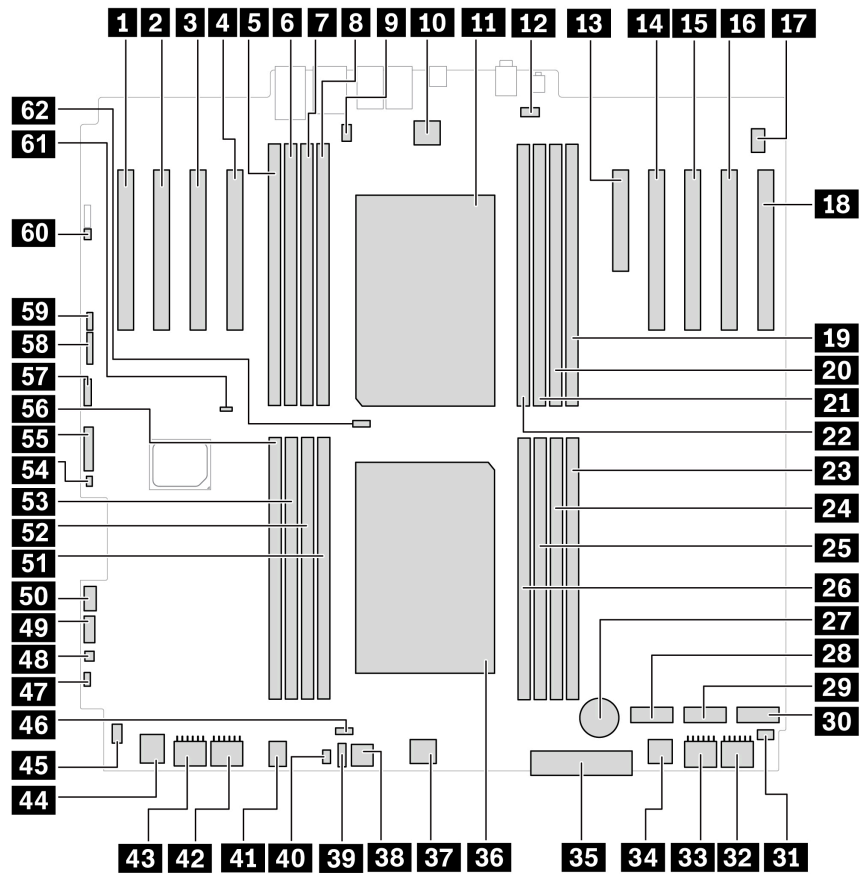

Figure 1. System board (front) part locations

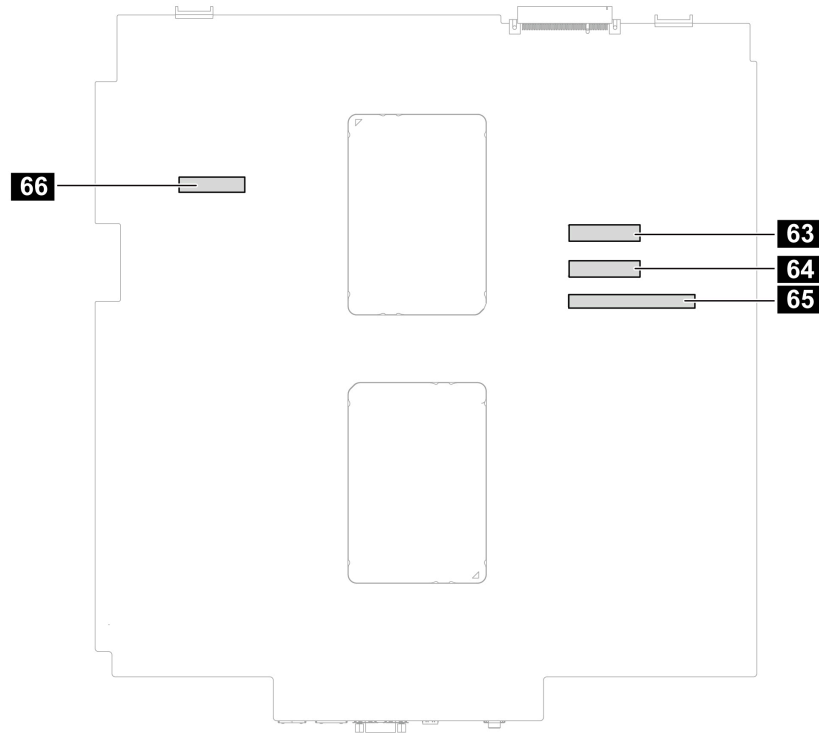

Figure 2. System board (back) part locations

Item	Item
1 PCIe card slot 9 (x 16, Gen4, Microprocessor 1)	21 PCIe card slot 8 (x 16, Gen5, Microprocessor 1)
3 PCIe card slot 7 (x 16, Gen4, Microprocessor 1)	4 PCIe card slot 6 (x 16, Gen5, Microprocessor 1)
5 Memory slot 9	6 Memory slot 10
7 Memory slot 11	8 Memory slot 12
9 Serial port (COM) connector	10 Rear-fan-assembly connector
11 Microprocessor 2*	12 Top memory-fan connector
13 PCIe card slot 5 (x 8, Gen4, Microprocessor 2)	14 PCIe card slot 4 (x 16, Gen5, Microprocessor 2)
15 PCIe card slot 3 (x 16, Gen5, Microprocessor 2)	16 PCIe card slot 2 (x 16, Gen4, Microprocessor 2)
17 Internal-speaker connector	18 PCIe card slot 1 (x 16, Gen4, Microprocessor 2)
19 Memory slot 16	20 Memory slot 15
21 Memory slot 14	22 Memory slot 13
23 Memory slot 1	24 Memory slot 2
25 Memory slot 3	26 Memory slot 4
27 Coin-cell battery	28 M.2 SSD slot 3
29 M.2 SSD slot 2	30 M.2 SSD slot 1
31 Right cover presence switch connector (intrusion switch connector)	32 Graphics card power connector 4

Item	Item
33 Graphics card power connector 3	34 Front fan assembly connector 2
35 Front panel connector	36 Microprocessor 1
37 Front fan assembly connector 1	38 Misc power connector
39 Thermal sensor connector	40 Logo LED connector
41 Bottom memory-fan connector	42 Graphics card power connector 1
43 Graphics card power connector 2	44 Front fan assembly connector 3
45 Left cover presence switch connector (intrusion switch connector)	46 Microprocessor 1 fan connector
47 Power button header	48 Thunderbolt™ power connector
49 Thunderbolt control connector	50 USB 3.2 Gen1
51 Memory slot 5	52 Memory slot 6
53 Memory slot 7	54 Drive_ACT
55 Alternative Trusted Platform Module (TPM) header	56 Memory slot 8
57 USB 2.0	58 BMC
59 VROC	60 Reset header
61 Clear CMOS jumper	62 Microprocessor 2 fan connector
63 MCIO connector 2	64 MCIO connector 1
65 Power distribution board connector	66 Drive_backplane

Prerequisites for hardware replacement

General prerequisites

Read *Generic Safety and Compliance Notices*.

Prerequisites for opening computer cover

-



During operation, some components become hot enough to burn the skin. Before you open the computer cover, remove any media from the drives, turn off the computer and connected devices, disconnect power, remove all cables and locking devices, and wait approximately 10 minutes until the computer is cool.

- Before reaching parts with cables, record the cable routing for future reference and then disconnect its cable from the system board.

Prerequisites for storage drive replacement

Attention: The internal storage drive is sensitive. Inappropriate handling might cause damage and loss of data. When handling the internal storage drive, observe the following guidelines:

- Replace the internal storage drive only for repair. The internal storage drive is not designed for frequent changes or replacement.

- Before replacing the internal storage drive, make backup copy of all the data that you want to keep.
- Do not touch the contact edge of the internal storage drive. Otherwise, the internal storage drive might get damaged.
- Do not apply pressure to the internal storage drive.
- Do not make the internal storage drive subject to physical shocks or vibration. Put the internal storage drive on soft material, such as a cloth, to absorb physical shocks.

Prerequisites for hot-swappable storage drives

You can install or replace a storage drive in the front access bay. The storage drive also can be hot-swappable, which means that you can install or replace the drive without even turning off your computer. Therefore, lock the storage drive to prevent the unexpected removal. The keys are attached at the rear of the computer. Store the keys in a secure place.

Attention: To avoid damage and loss of data, ensure that the operating system of your computer does not reside on the storage drive installed in the front access bay. If the requirement is not met, do not remove or install the storage drive when the computer is turned on.

ThinkStation logo badge

Before you start, ensure that you have read “Prerequisites for hardware replacement” on page 34.

Removal steps

Remove the ThinkStation logo badge.

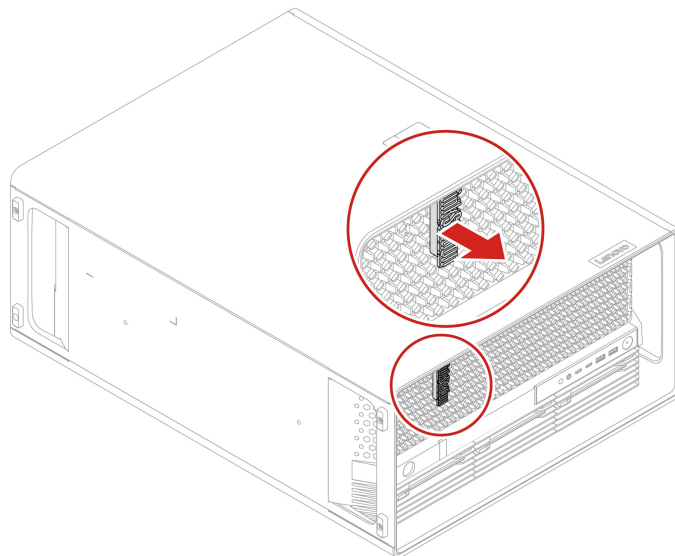

ID badge

Before you start, ensure that you have read “Prerequisites for hardware replacement” on page 34.

Removal steps

Remove the ID badge.

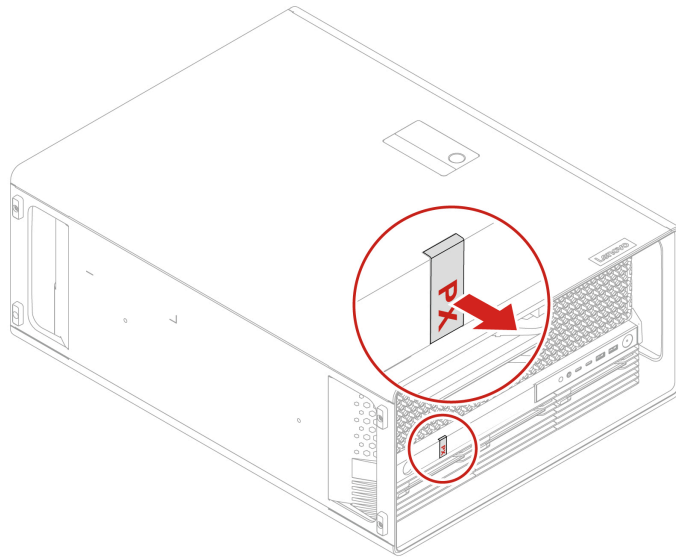

Dummy cover for the upper PSU bay

Before you start, ensure that you have read “Prerequisites for hardware replacement” on page 34.

Removal steps

Remove the dummy cover for the upper PSU bay.

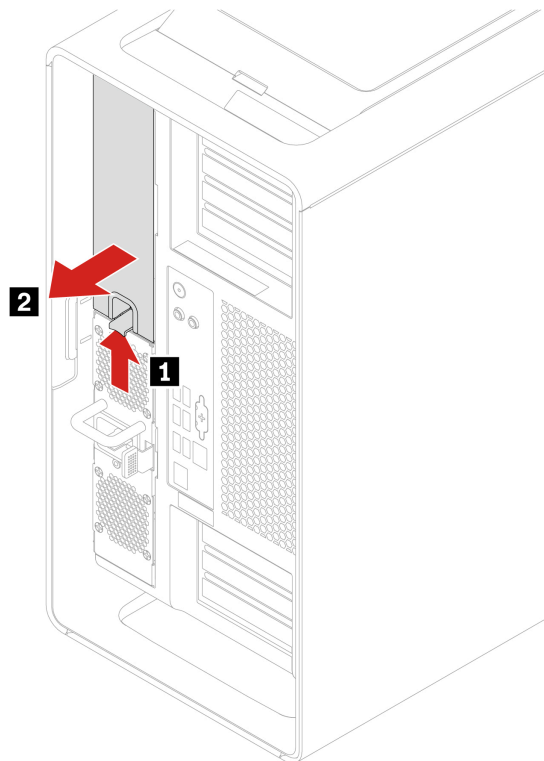

Power supply assembly

- Before you start, ensure that you have read “Prerequisites for hardware replacement” on page 34.
- The power supply assembly is hot-swappable.

Removal steps

Remove the power supply assembly.

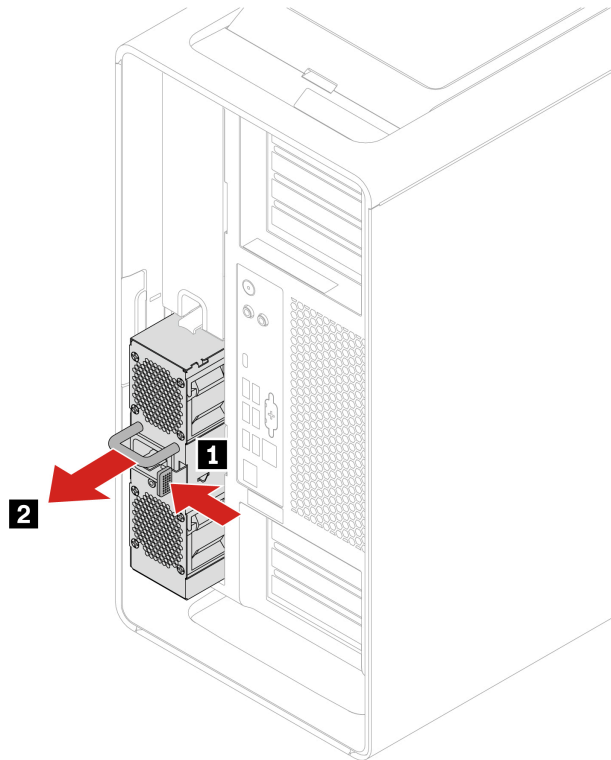

Top cover

Before you start, ensure that you have read “Prerequisites for hardware replacement” on page 34.

Removal steps

Remove the top cover.

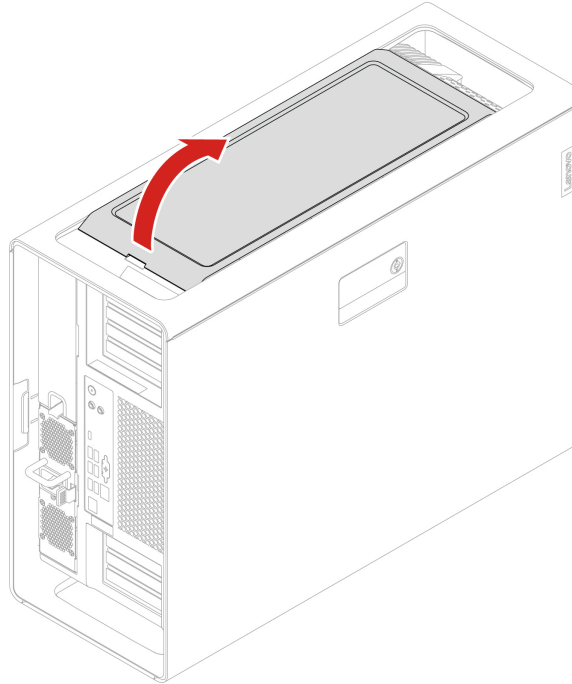

Wi-Fi antenna cover

Before you start, ensure that you have read “Prerequisites for hardware replacement” on page 34.

Removal steps

1. Remove the “Top cover” on page 37.
2. Remove the Wi-Fi antenna cover.

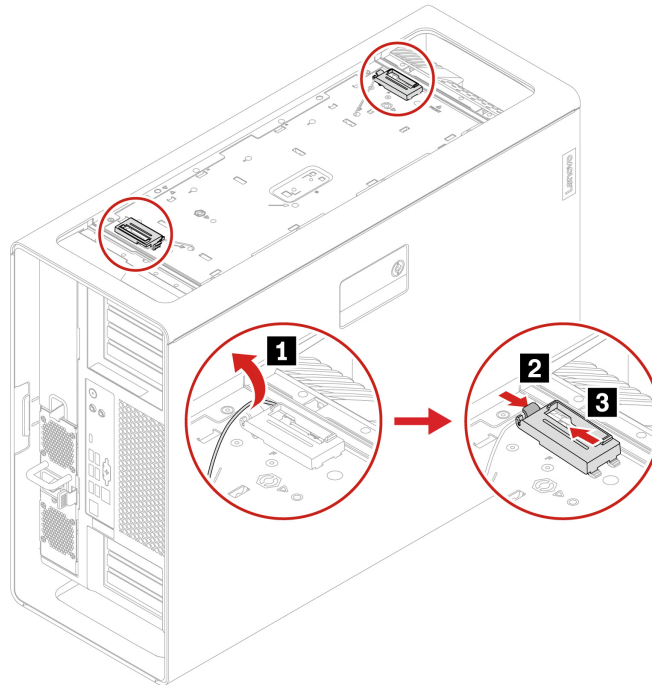

Left side cover

Before you start, ensure that you have read “Prerequisites for hardware replacement” on page 34.

Removal steps

1. Lay the computer on its side for easier access to the left side cover.
2. Remove the left side cover.

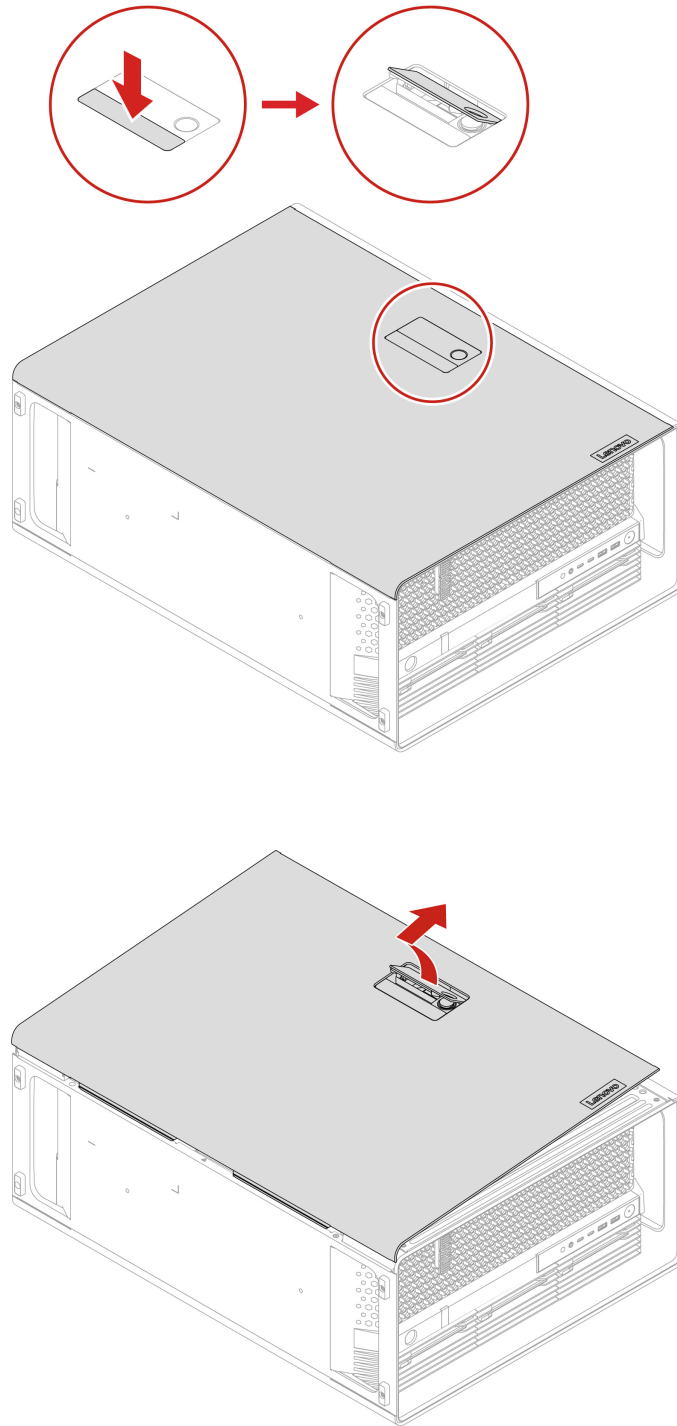

Installation steps

Install the left side cover.

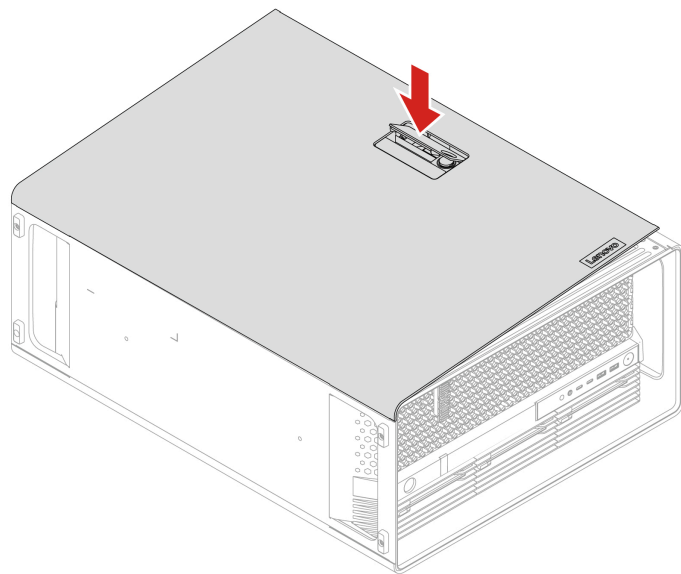
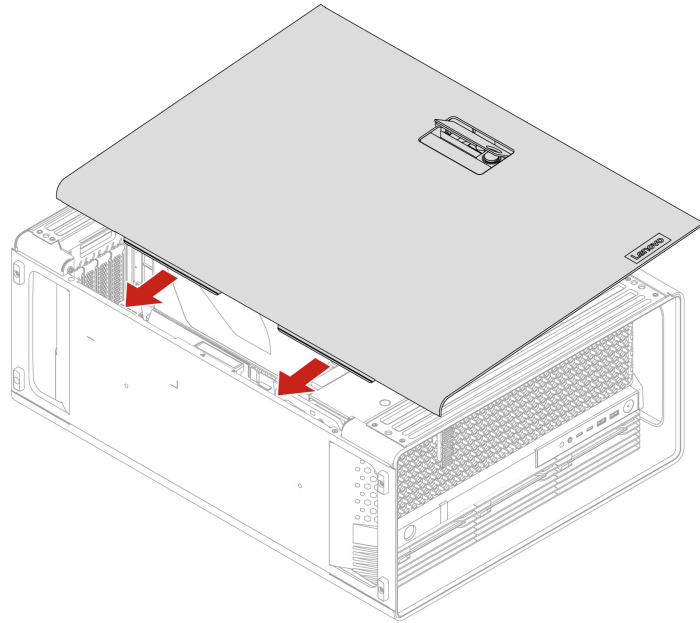

Note: If a locking device is available, use it to lock the computer after installing the computer cover.

Lock kit for the left side cover

Before you start, ensure that you have read “Prerequisites for hardware replacement” on page 34.

Removal steps

1. Remove the “Left side cover” on page 39.
2. Remove the left side cover lock.

Note: Loosen the two screws that secure the lock handle cover. The two screws cannot be removed from the lock handle cover.

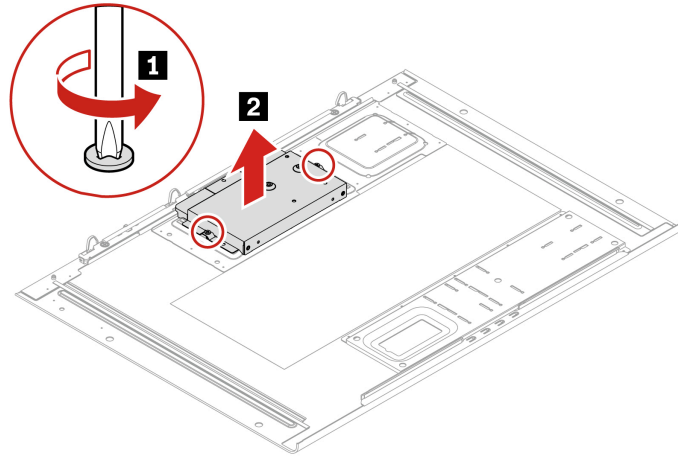

Screw (quantity)	Color	Torque
6-32*3.8 mm, Zn coated (2)	Blue	3.0 ± 0.5 lb/in

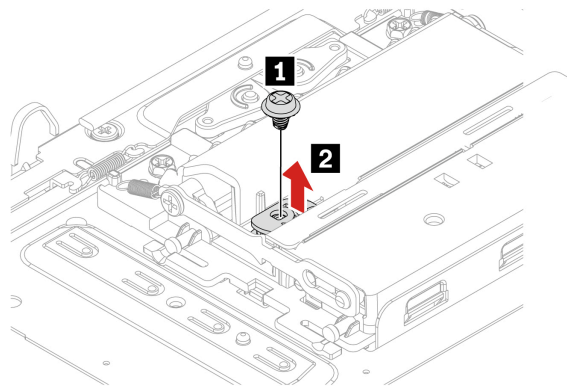

Screw (quantity)	Color	Torque
M3 x 4.2 mm, Zn coated (1)	Blue	5.0 ± 0.5 lb/in

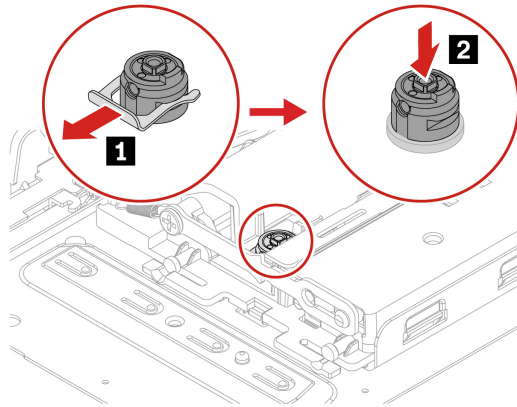

Installation steps

Install the left side cover lock.

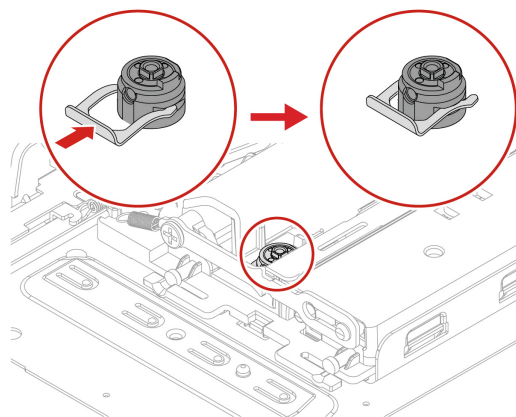
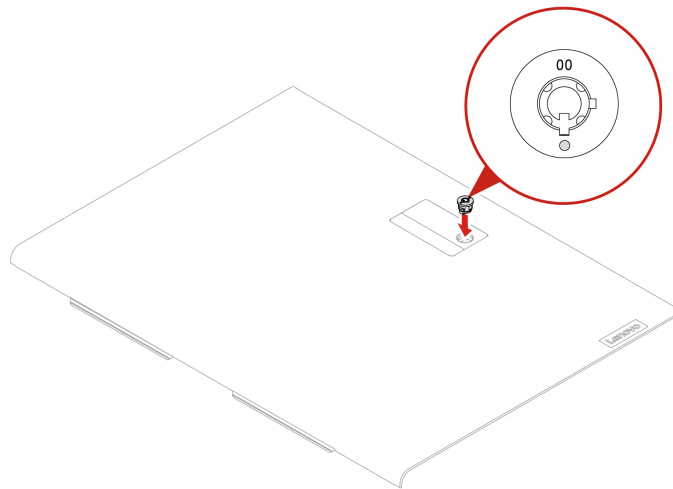

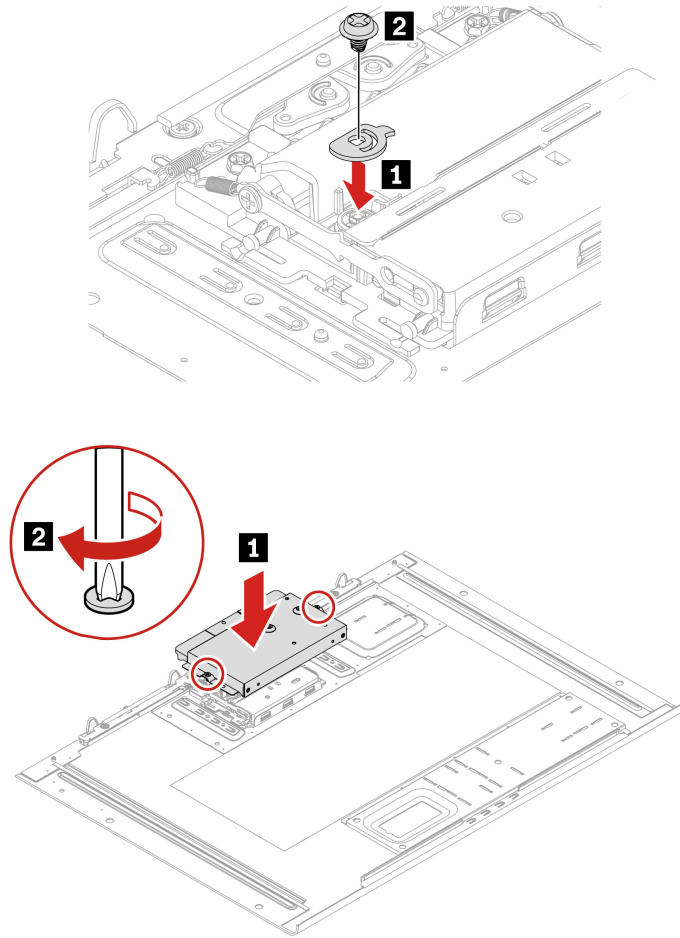

Right side cover

Before you start, ensure that you have read “Prerequisites for hardware replacement” on page 34.

Removal steps

1. Remove the “Left side cover” on page 39.
2. Remove the right side cover.

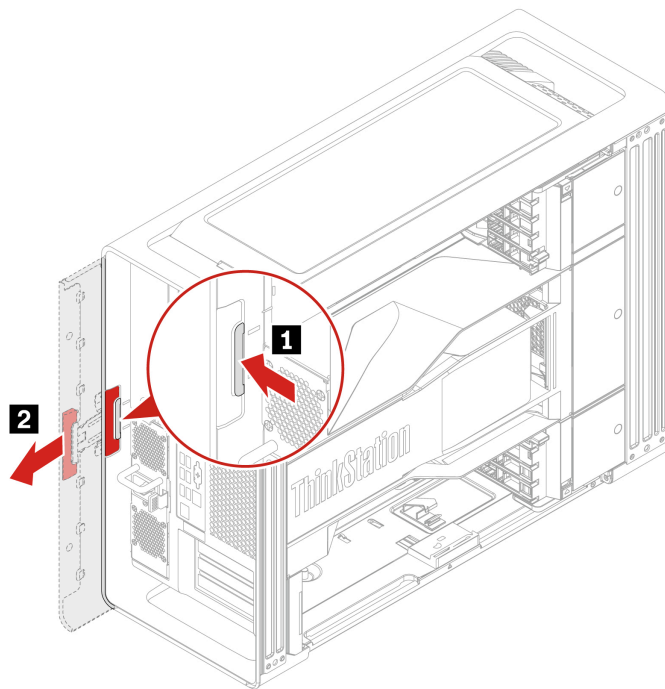
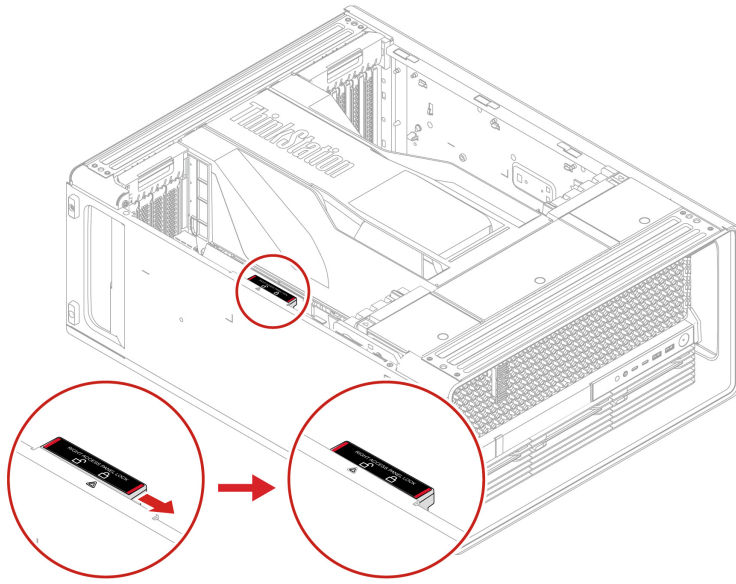

Installation steps

Install the right side cover.

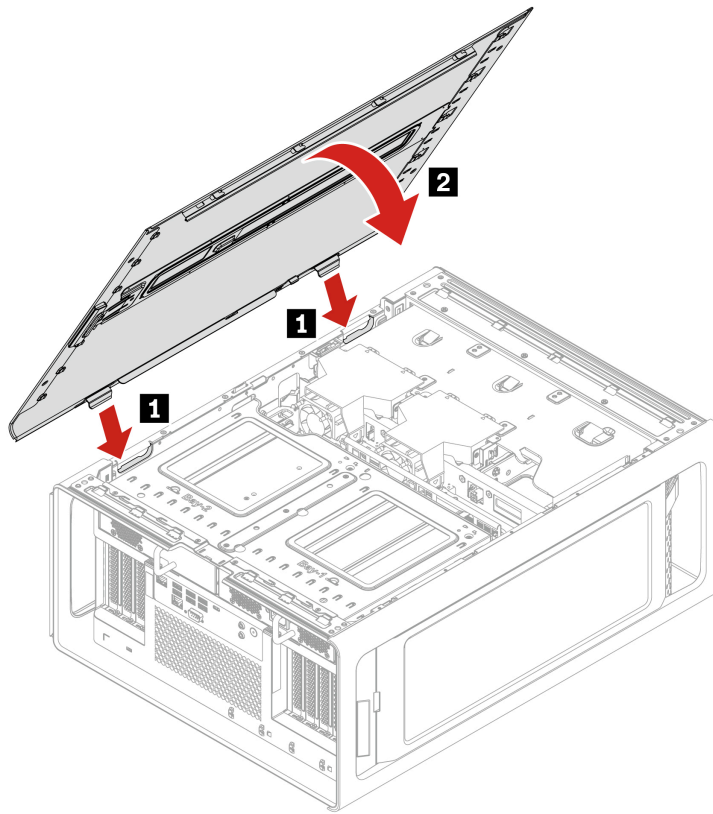
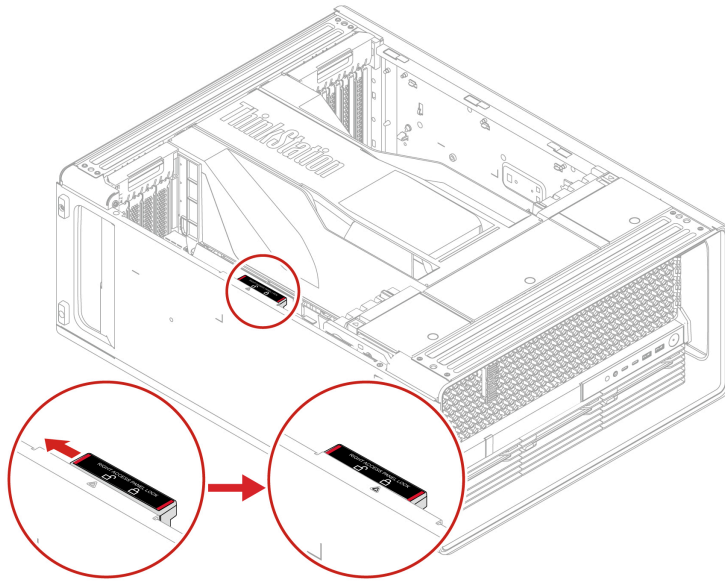

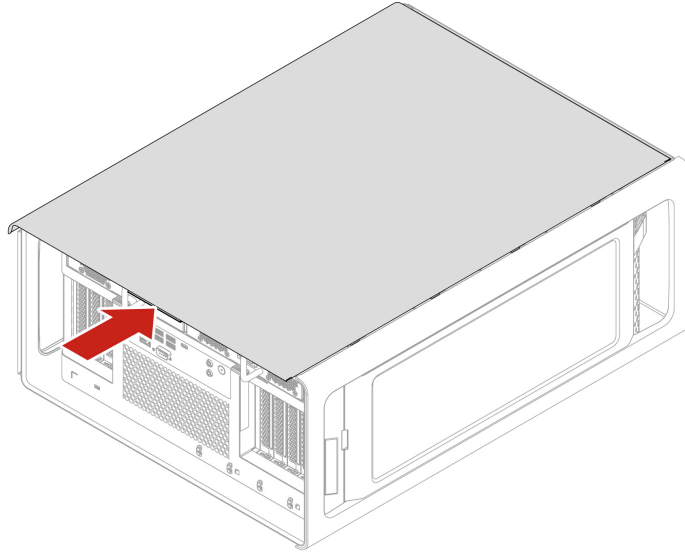

CPU duct

Before you start, ensure that you have read “Prerequisites for hardware replacement” on page 34.

Removal steps

1. Remove the “Left side cover” on page 39.
2. Remove the CPU duct.

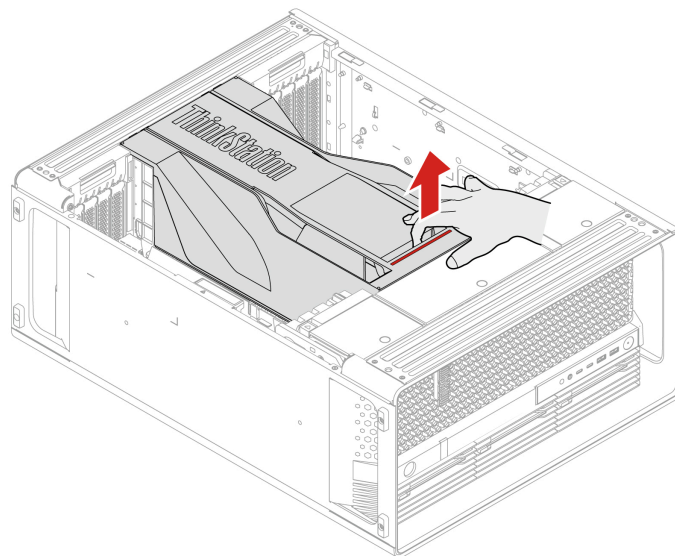

Blank bezel

Before you start, ensure that you have read “Prerequisites for hardware replacement” on page 34.

Removal steps

1. Remove the HDD bracket beside the blank bezel. See “HDD in the front access bay” on page 52.
2. Remove the blank bezel.

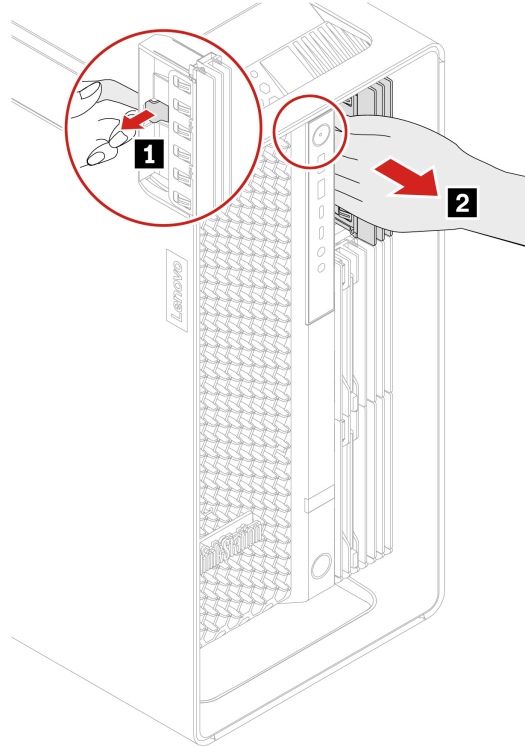

Fans

By reading this section, you will learn to replace the fans in your computer.

Front fan assembly

Before you start, ensure that you have read “Prerequisites for hardware replacement” on page 34.

Removal steps

1. Remove the “Left side cover” on page 39.
2. Remove the front fan assembly.

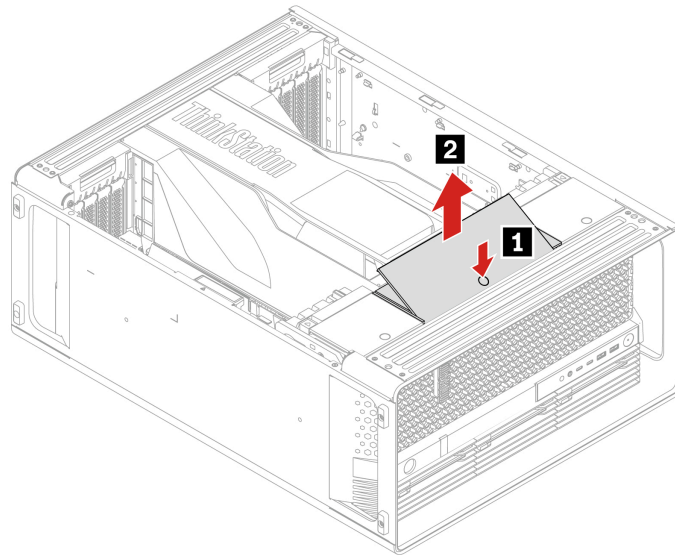

Front fan bracket

Before you start, ensure that you have read “Prerequisites for hardware replacement” on page 34.

Removal steps

1. Remove the following parts, if any:
 - a. “Left side cover” on page 39
 - b. “CPU duct” on page 47
 - c. “Front fan assembly” on page 48
2. Remove the front fan bracket.

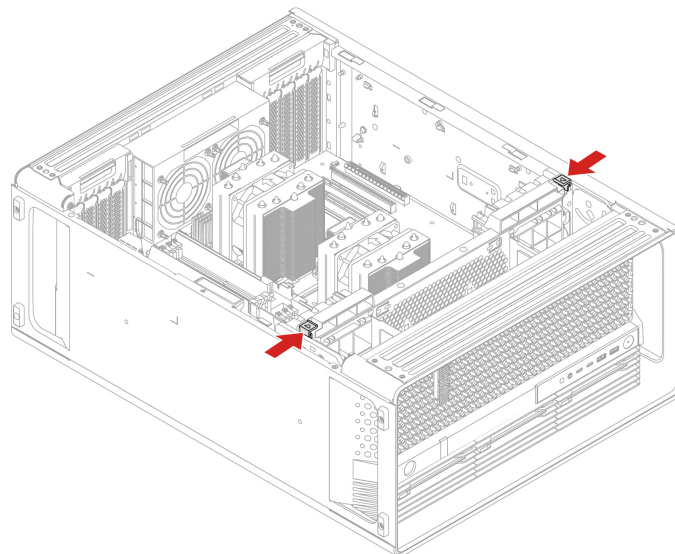

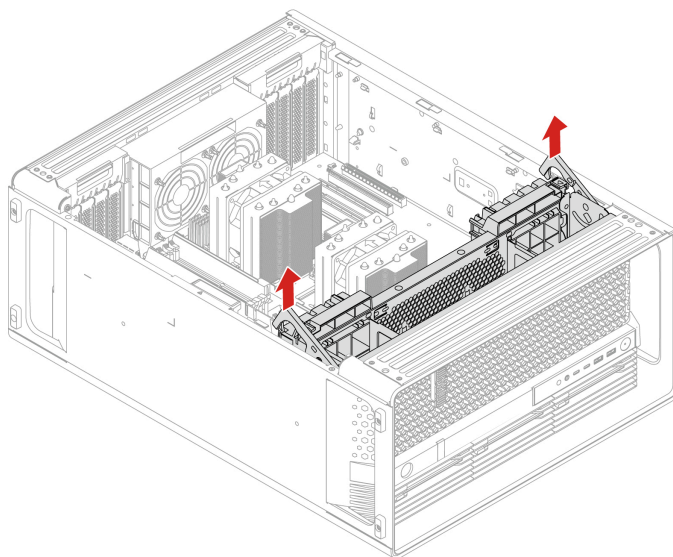

Rear fan assembly

Before you start, ensure that you have read “Prerequisites for hardware replacement” on page 34.

Removal steps

1. Remove the following parts, if any:
 - a. “Left side cover” on page 39
 - b. “CPU duct” on page 47
2. Remove the rear fan assembly.

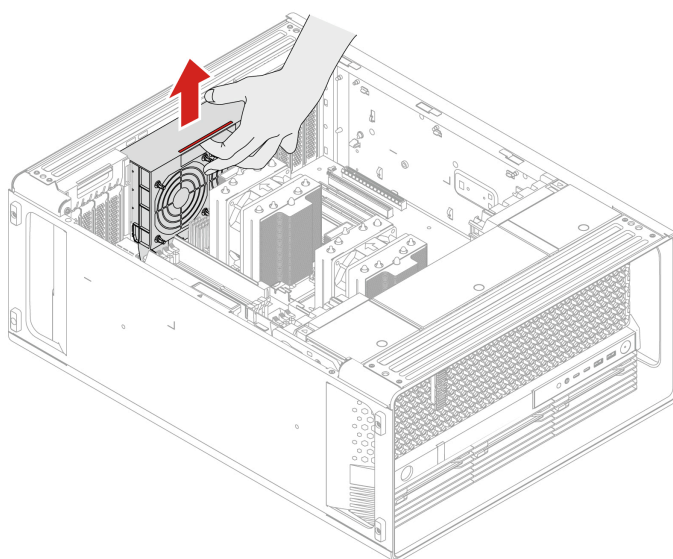

Storage fan assembly

Before you start, ensure that you have read “Prerequisites for hardware replacement” on page 34.

Removal steps

1. Remove the following parts, if any:
 - a. “Left side cover” on page 39
 - b. “Right side cover” on page 44
2. Remove the storage fan assembly.

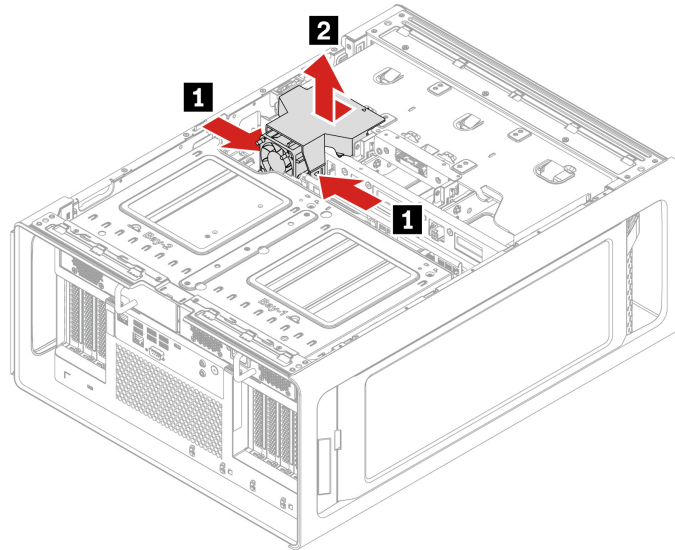

Memory fan

Before you start, ensure that you have read “Prerequisites for hardware replacement” on page 34.

Removal steps

1. Remove the following parts, if any:
 - a. “Left side cover” on page 39
 - b. “CPU duct” on page 47
 - c. “Front fan assembly” on page 48
 - d. “Front fan bracket” on page 49
 - e. “Rear fan assembly” on page 50
2. Remove the memory fan.

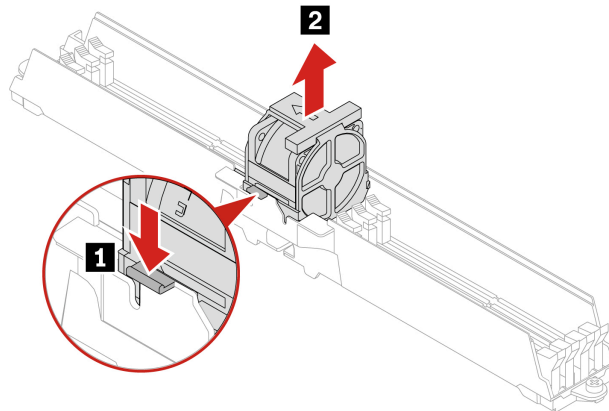

Storage drives

By reading this section, you will learn to replace storage drives in your computer.

HDD in the front access bay

Before you start, ensure that you have read “Prerequisites for hardware replacement” on page 34.

Removal steps

You might need to use the key attached at the rear of the computer to unlock the front access bay and then remove the HDD.

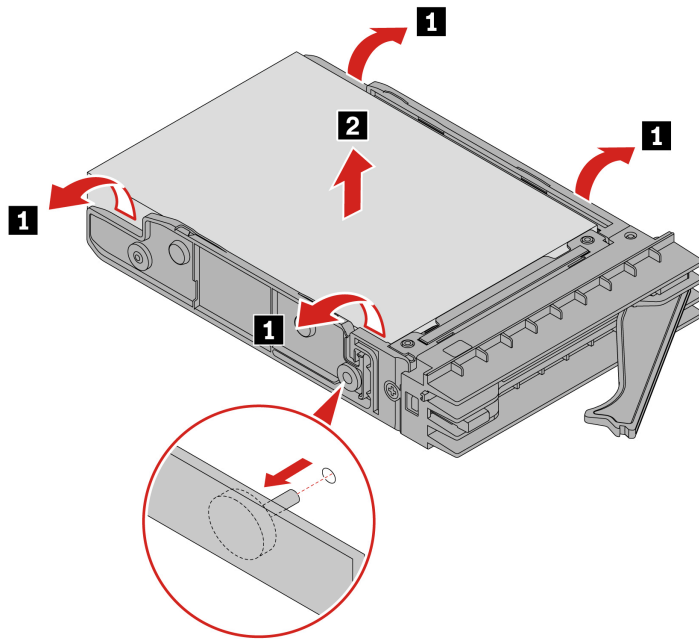
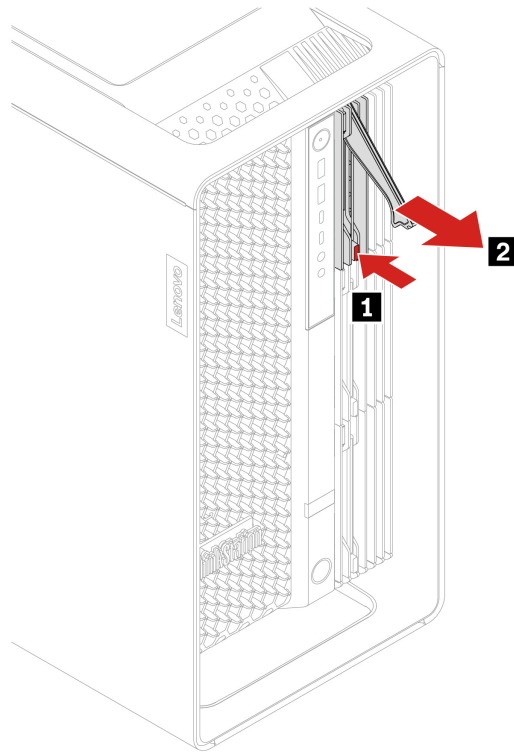

Installation steps

Install the HDD.

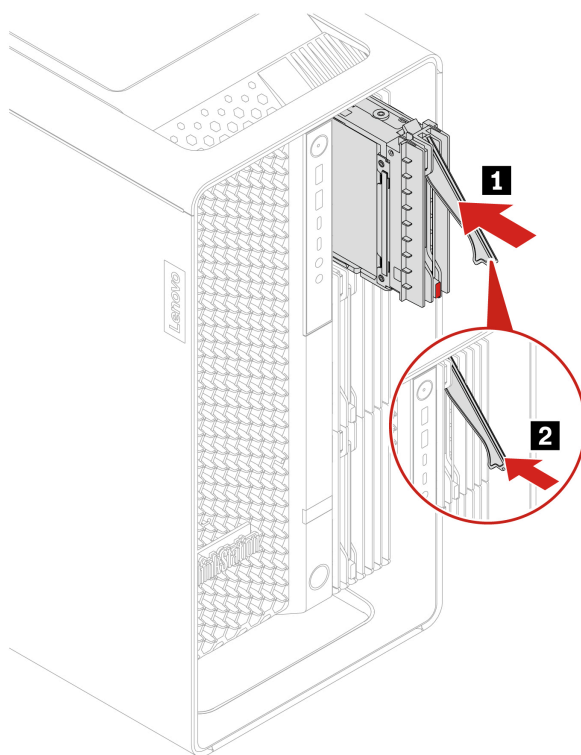

HDD in the PSU bay storage enclosure

Before you start, ensure that you have read “Prerequisites for hardware replacement” on page 34.

Removal steps

1. Remove the following parts, if any:
 - a. “Left side cover” on page 39
 - b. “Right side cover” on page 44
2. Remove the HDD in the PSU bay storage enclosure.

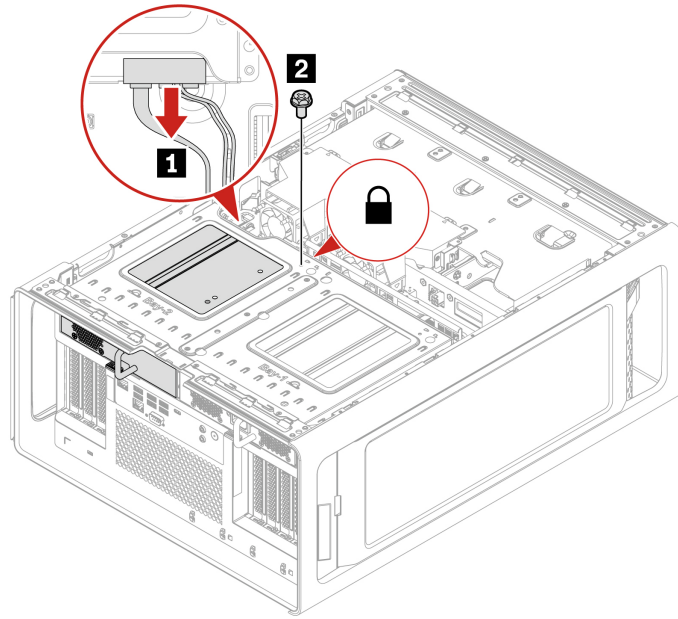

Screw (quantity)	Color	Torque
M3 x 5 mm, Nickel coated (1)	Black	5.0 ± 0.5 lb/in

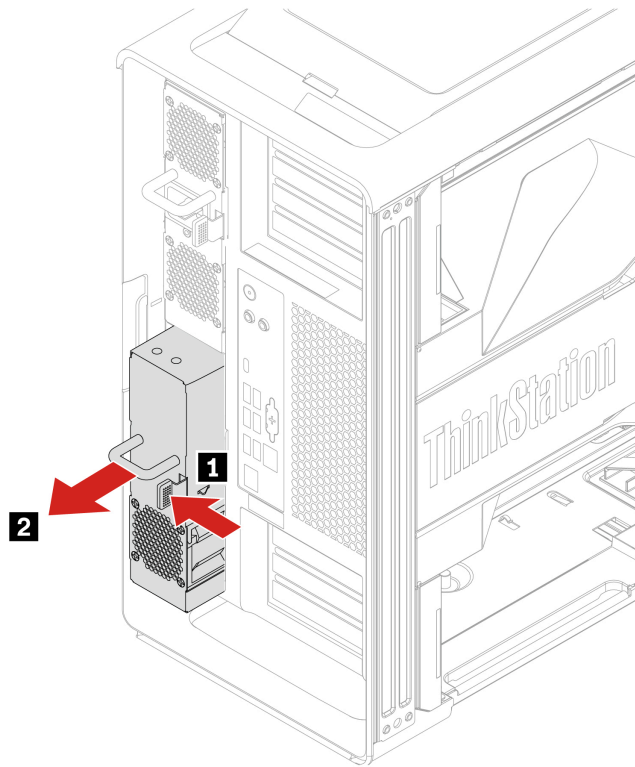

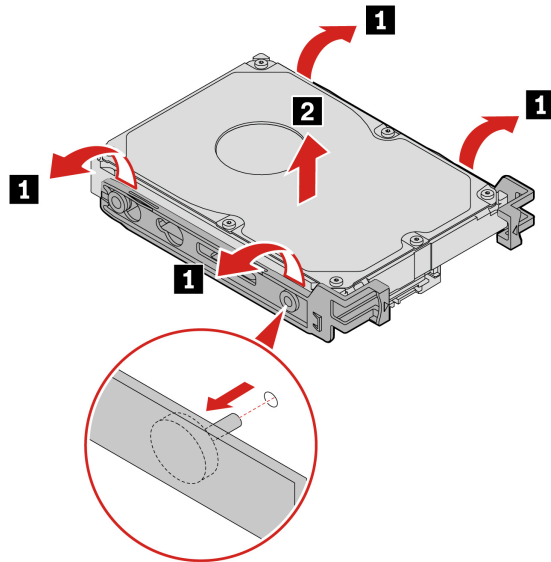
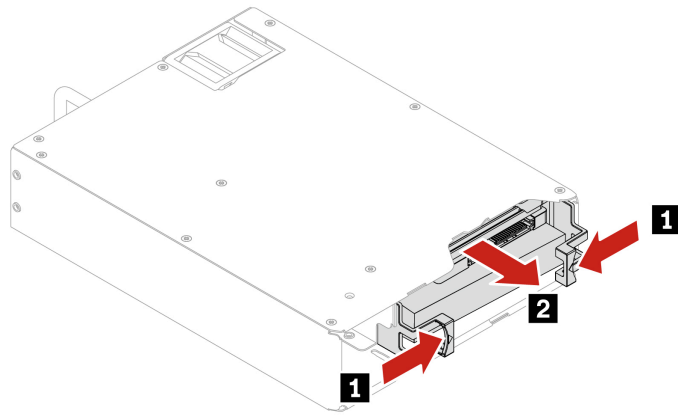

M.2 SSD in the front access bay

Before you start, ensure that you have read “Prerequisites for hardware replacement” on page 34.

Removal steps

Remove the M.2 SSD.

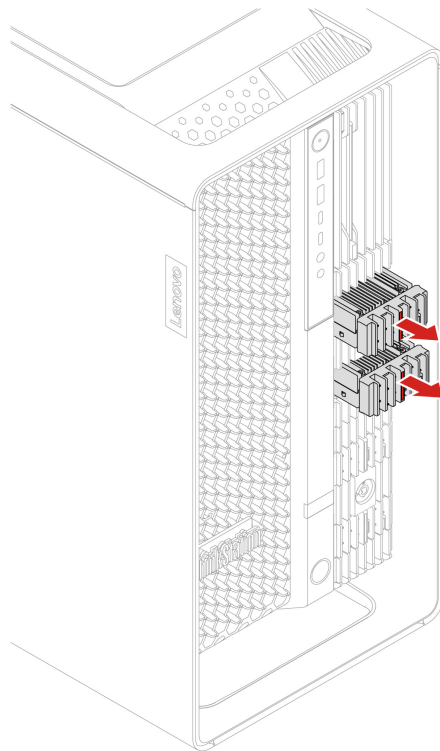
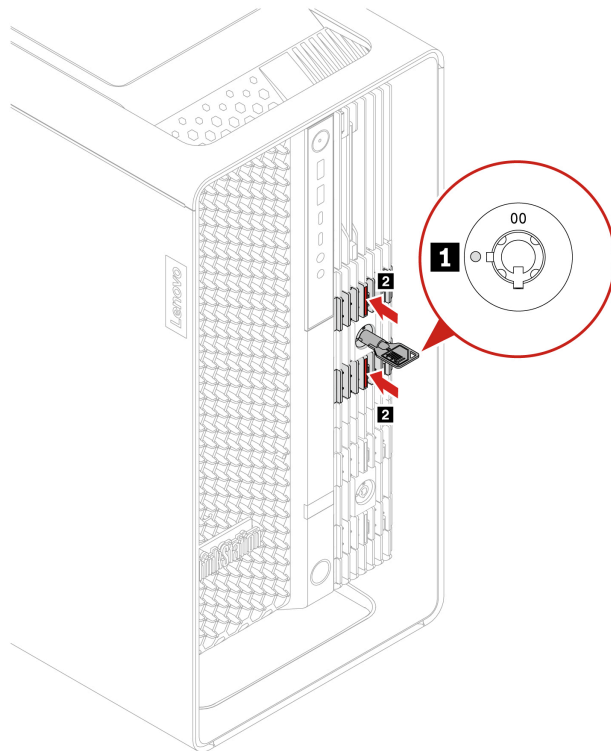

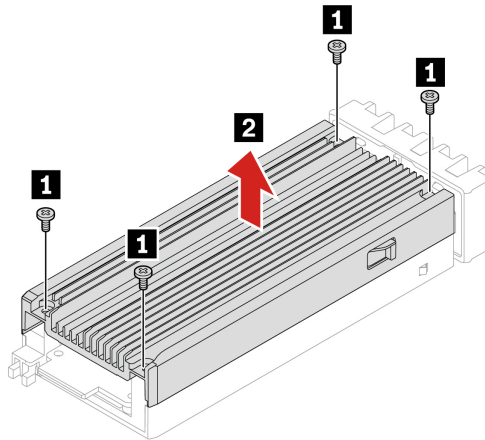

Screw (quantity)	Color	Torque
M2 x 4.5 mm, Zn coated (4)	Black	1.5 ± 0.2 lb/in

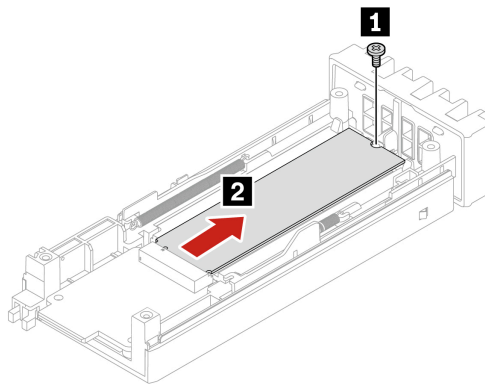

Screw (quantity)	Color	Torque
M2 x 4.5 mm, Zn coated (1)	Black	1.5 ± 0.2 lb/in

Dual M.2 SSD enclosure

Before you start, ensure that you have read “Prerequisites for hardware replacement” on page 34.

Removal steps

1. Remove the following parts, if any:
 - a. “M.2 SSD in the front access bay” on page 56
 - b. “Left side cover” on page 39
 - c. “Right side cover” on page 44
 - d. “Storage fan assembly” on page 51
2. Remove the dual M.2 SSD enclosure.

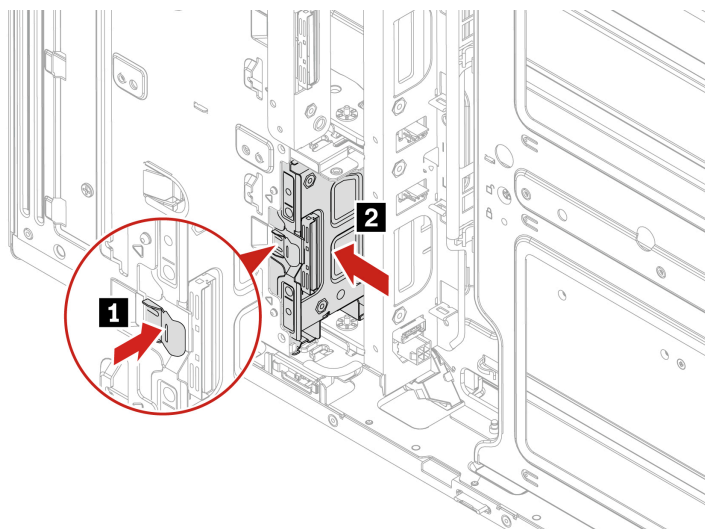

Onboard M.2 SSD and its heatsink kit

Before you start, ensure that you have read “Prerequisites for hardware replacement” on page 34.

Removal steps

1. Remove the following parts, if any:
 - a. “Left side cover” on page 39
 - b. “CPU duct” on page 47
 - c. “Front fan assembly” on page 48
 - d. “Front fan bracket” on page 49
2. Remove the onboard M.2 SSD with its heatsink kit.

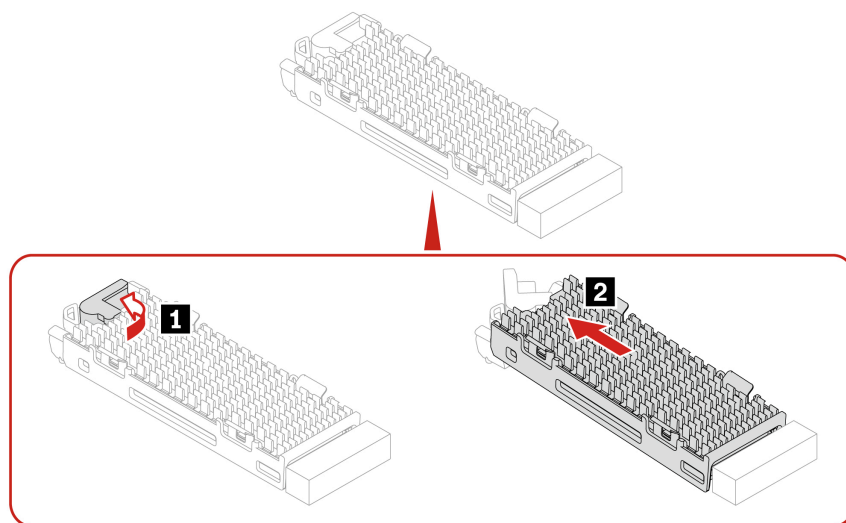

3. Remove the M.2 SSD from its heatsink kit.
 - Gen 4 M.2 SSD

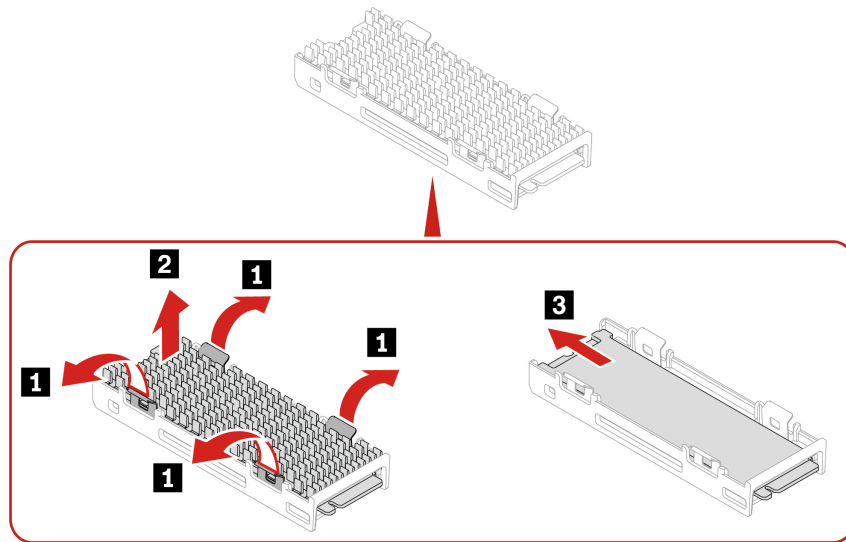

- Gen 5 M.2 SSD

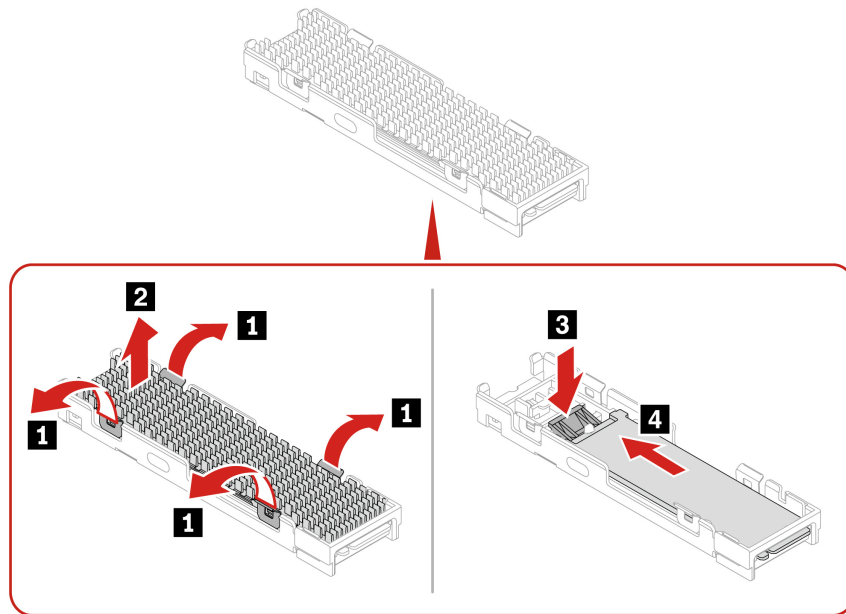

Installation steps

1. Remove the protective film from both heatsink and thermal pad before installing the onboard M.2 SSD.
2. Install the M.2 SSD into its heatsink kit.

- Gen 4 M.2 SSD

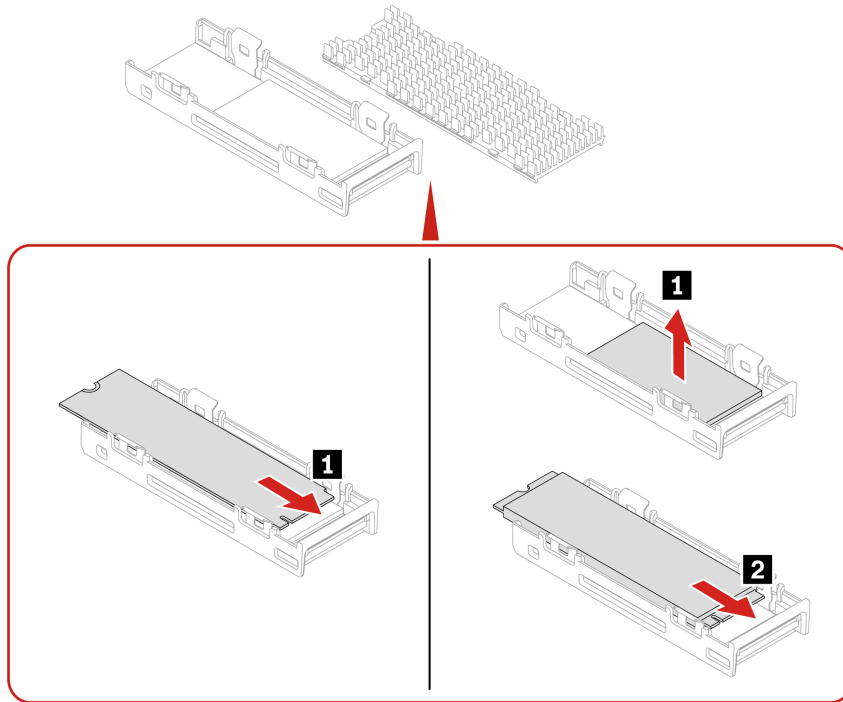

Note: If the new Gen 4 M.2 SSD is double-sided, remove the 1.5-mm thick thermal pad upward first.

- Gen 5 M.2 SSD

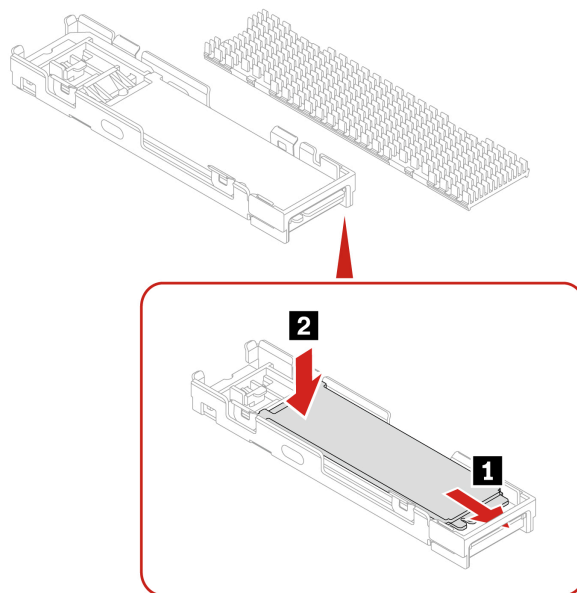

3. Install the M.2 SSD heatsink.

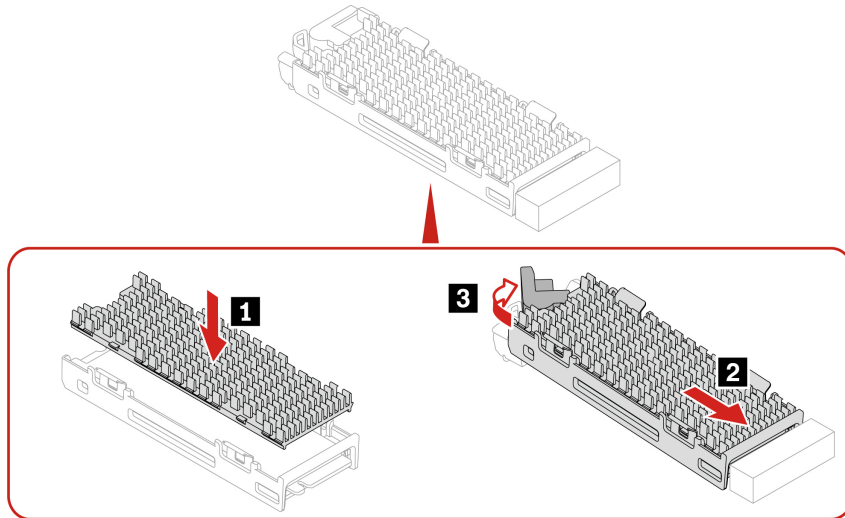

M.2 SSD on an M.2 SSD PCIe adapter

- Before you start, ensure that you have read “Prerequisites for hardware replacement” on page 34.
- Install M.2 SSDs in the following order as shown:

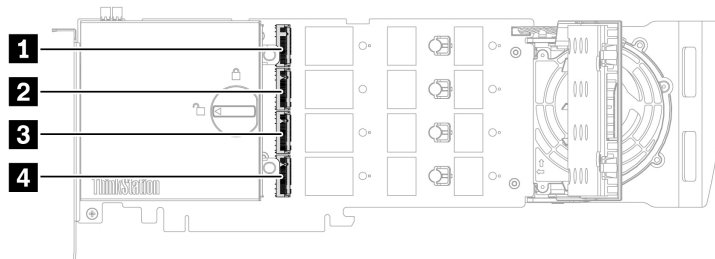

- For better performance, it's recommended that the generation of M.2 SSD match with the generation of M.2 SSD PCIe adapter. For example, install Gen 4 M.2 SSD on Gen 4 M.2 SSD PCIe adapter and install Gen 5 M.2 SSD on Gen 5 M.2 SSD PCIe adapter.

Replacement steps

1. Remove the following parts, if any:
 - a. “Left side cover” on page 39
 - b. “CPU duct” on page 47
2. Remove the M.2 SSD PCIe adapter from the PCIe card slot. See “Full-length PCIe card” on page 71.
3. Replace the M.2 SSD on the M.2 SSD PCIe adapter.

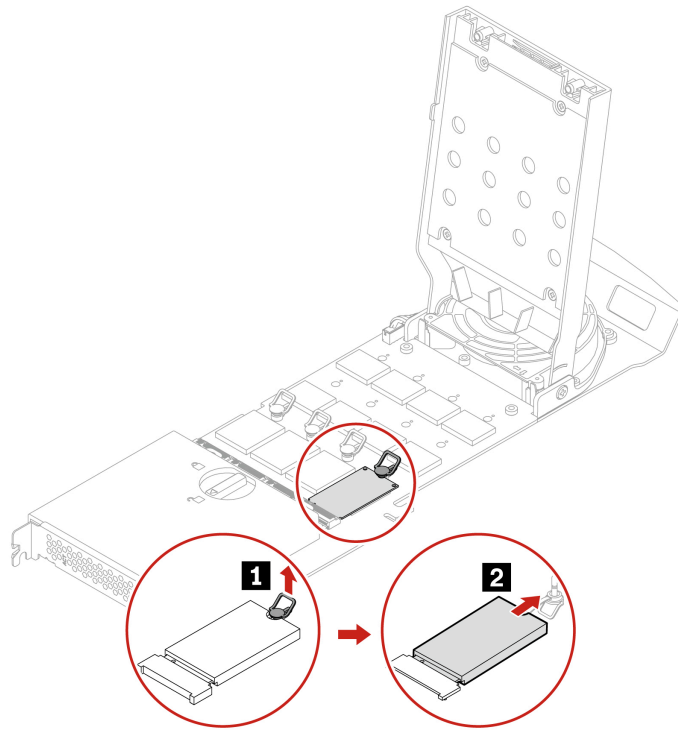
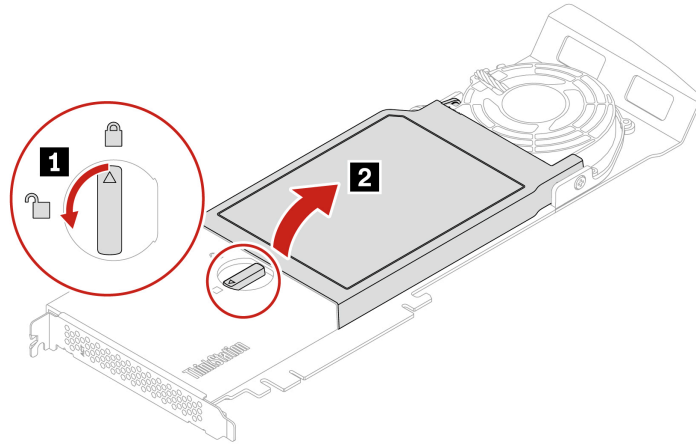

If necessary, move the retention latch to an appropriate location to suit the length of the new M.2 SSD.

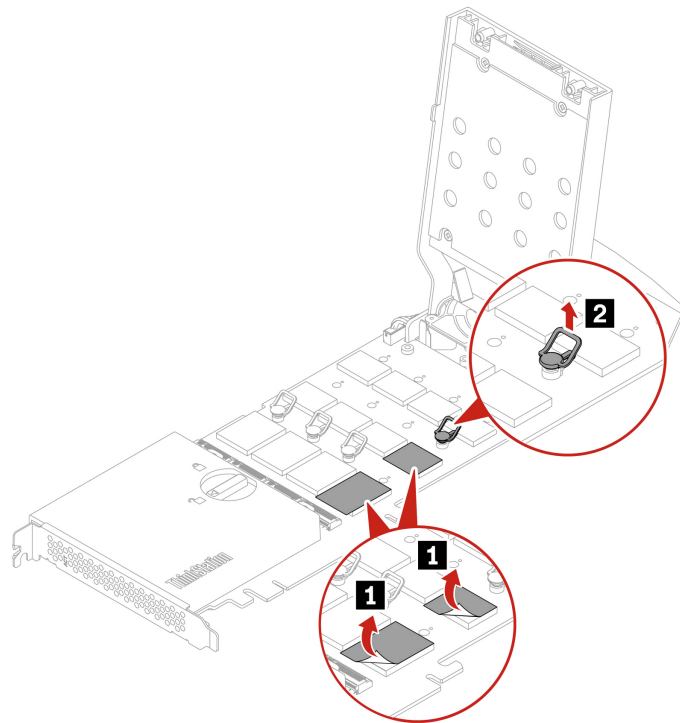
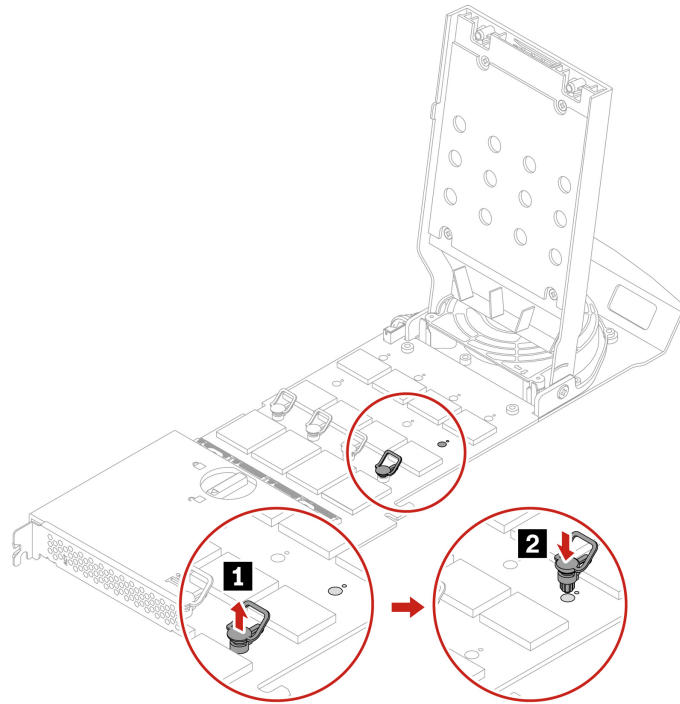

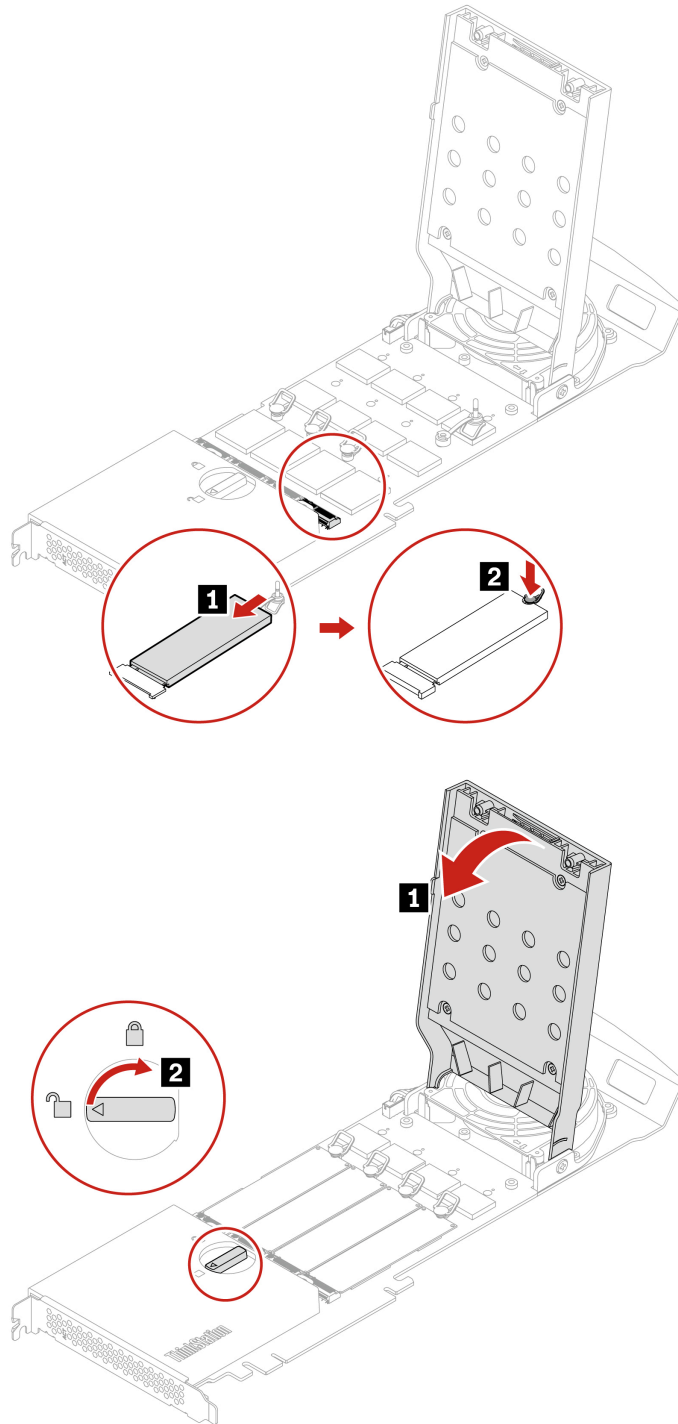

Note: Install the M.2 SSD PCIe adapter in a PCIe x16 card slot on the system board. See “System board” on page 32.

PCIe cards

By reading this section, you will learn to replace PCIe cards, including graphics cards, in your computer.

NVLINK retainer

Before you start, ensure that you have read “Prerequisites for hardware replacement” on page 34.

Removal steps

1. Remove the “Left side cover” on page 39.
2. Remove the NVLINK retainer.

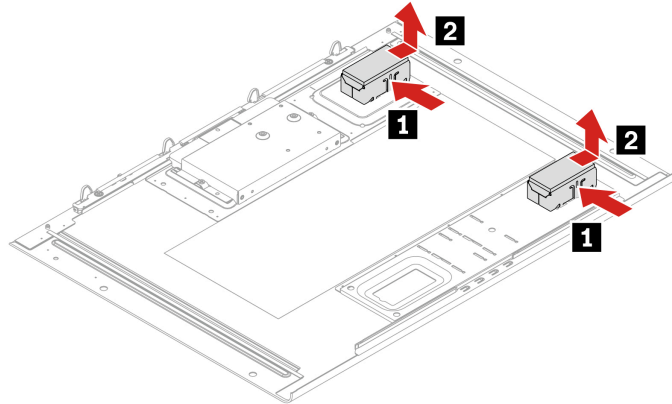

NVLINK bridge

- Before you start, ensure that you have read “Prerequisites for hardware replacement” on page 34.
- The NVLINK bridge is shipped in an accessory box within the computer carton box. You need to take it out from the packaging and install it by yourself.

Installation steps

1. Remove the following parts, if any:
 - a. “Left side cover” on page 39
 - b. “CPU duct” on page 47
2. Install the NVLINK bridge.

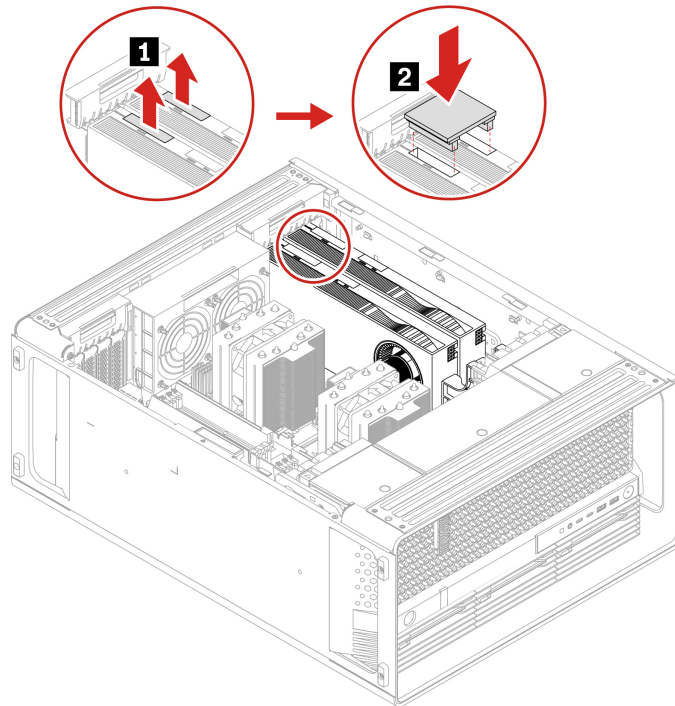

Removal steps

1. Remove the following parts, if any:
 - a. “Left side cover” on page 39
 - b. “CPU duct” on page 47
2. Remove the NVLINK bridge.

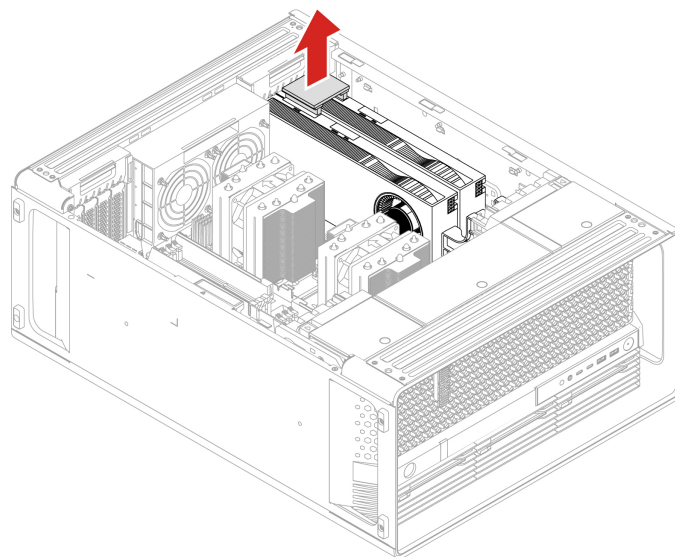

Super capacitor module

Before you start, ensure that you have read “Prerequisites for hardware replacement” on page 34.

Removal steps

1. Remove the following parts, if any:
 - a. “Left side cover” on page 39
 - b. “CPU duct” on page 47
2. Remove the super capacitor module.

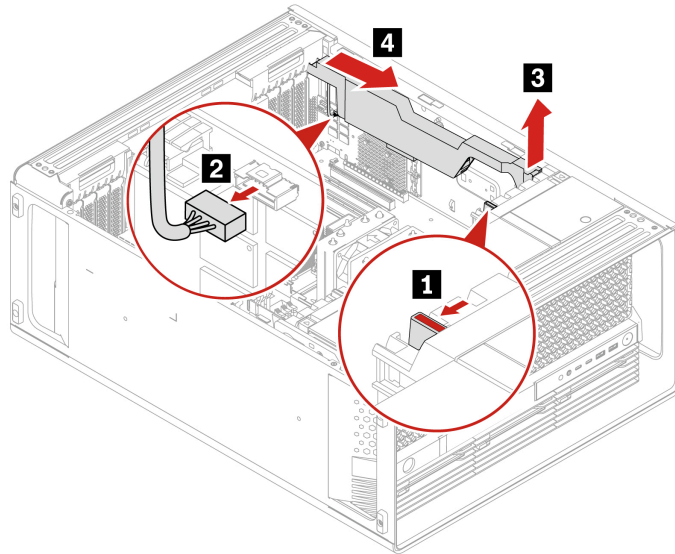

Note: When installing a new super capacitor module, connect the super capacitor module cable to the super capacitor module connector (J14) on the RAID card.

PCIe bracket

Before you start, ensure that you have read “Prerequisites for hardware replacement” on page 34.

Removal steps

1. Remove the following parts, if any:
 - a. “Left side cover” on page 39
 - b. “CPU duct” on page 47
2. Remove the PCIe bracket.

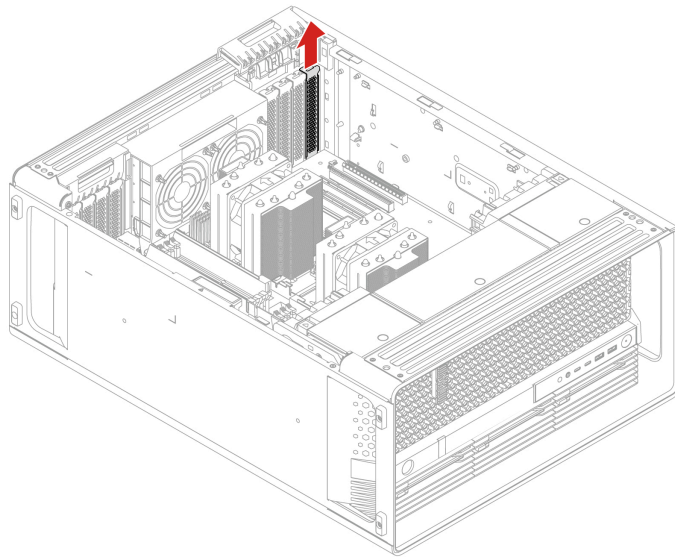
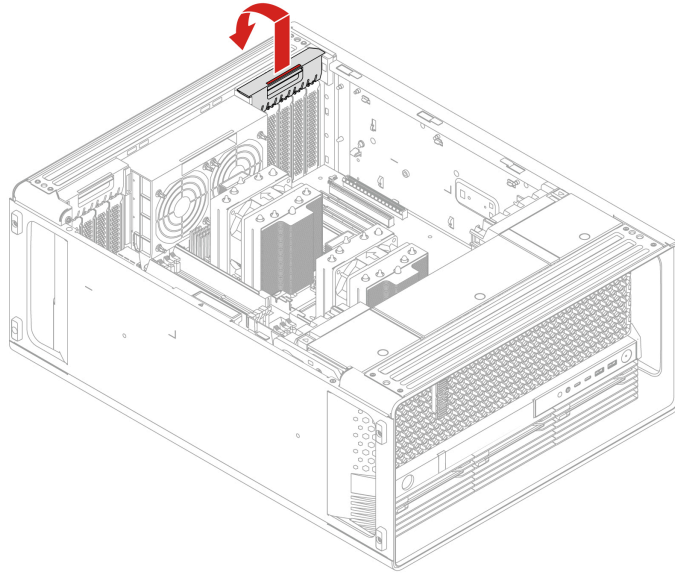

Half-length PCIe card

Before you start, ensure that you have read “Prerequisites for hardware replacement” on page 34.

Removal steps

1. Remove the following parts, if any:
 - a. “Left side cover” on page 39
 - b. “CPU duct” on page 47
2. Remove the PCIe card.
 - a. Remove the PCIe card retainer. The PCIe card retainer is only available on some graphics cards.

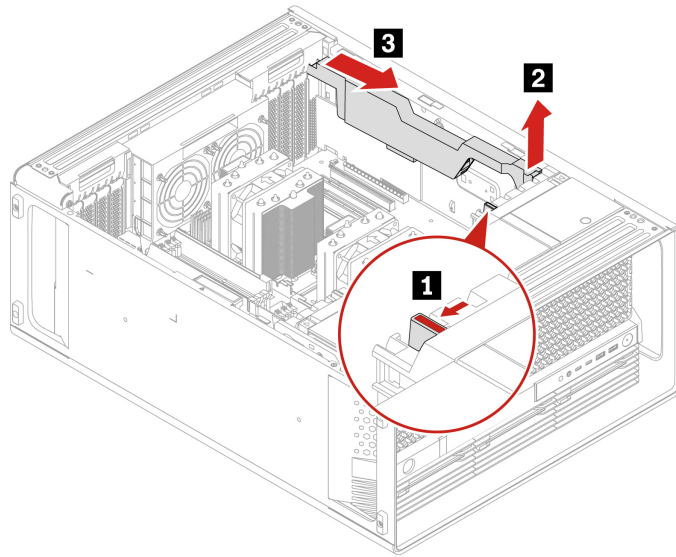

- b. Open the handle and remove the PCIe card. The card might fit tightly into the slot. If necessary, alternately move each side of the card a small amount until the card is removed from the slot.

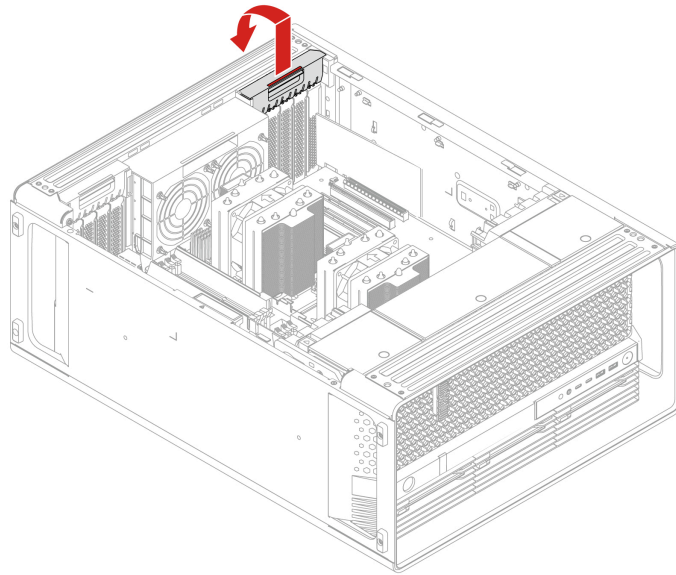

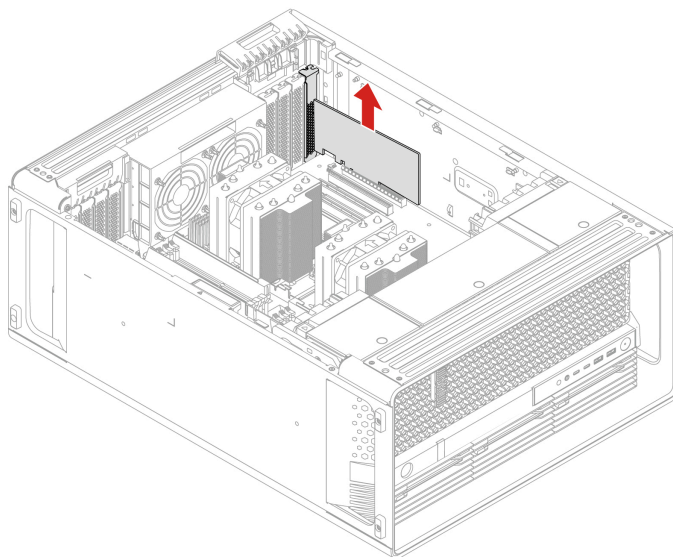

c. For some Ethernet adapter cards, the following fiber modules can be removed.

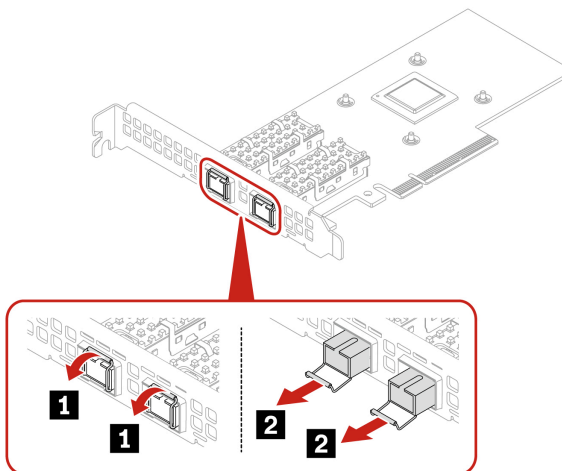

Full-length PCIe card

Before you start, ensure that you have read “Prerequisites for hardware replacement” on page 34.

Removal steps

1. Remove the following parts, if any:
 - a. “Left side cover” on page 39
 - b. “CPU duct” on page 47
2. Remove the full-length PCIe card.
 - a. Open the handle.

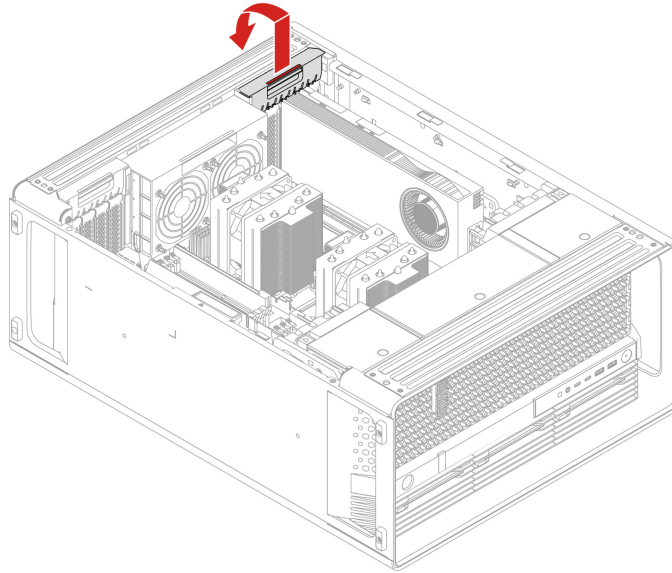

- b. Remove the PCIe card. The card might fit tightly into the slot. If necessary, alternately move each side of the card a small amount until the card is removed from the slot.

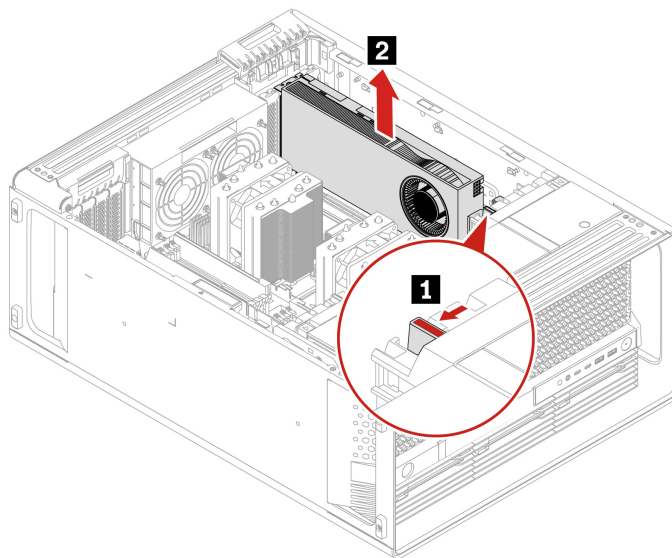

- c. Remove the PCIe card extender if needed.

Notes:

- For computer models with GFX RTX 4000 Ada, the graphics card and the PCIe card extender work as a CRU assembly. Do not try to remove the extender.
- For computer models with double-width or wider graphics cards (such as NVIDIA RTX 6000 Ada and GeForce RTX 4080), the PCIe card extender is a customized CRU part. You can remove it according to the following illustration.
- If you want to install a double-width or wider graphics card, install the customized PCIe card extender first.

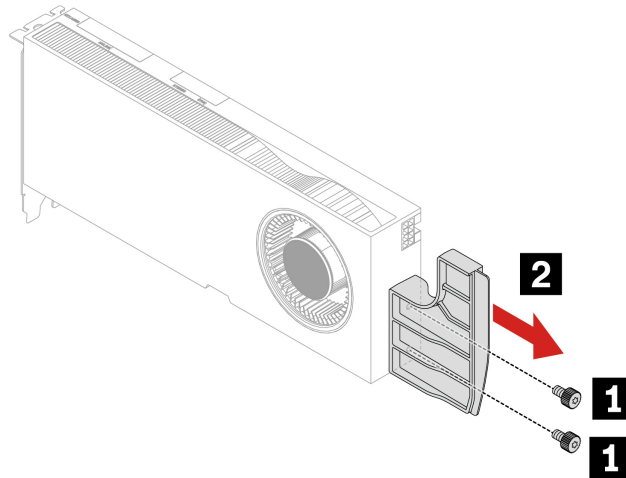

Screw (quantity)	Color	Torque
M3 x 5.5 mm, Nickel coated (2)	Black	5.5 ± 0.5 lb/in

PCIe card installation rule

Before installing PCIe card, you need to remove “PCIe card bracket” on page 68.

Install PCIe cards according to the following order and special rules for certain PCIe cards.

- **Installation order**

- 1 CPU

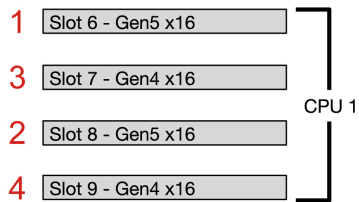

- 2 CPUs

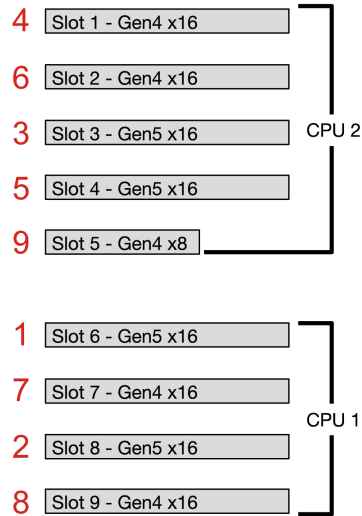

- **Special installation rules for certain PCIe cards**

PCIe card	Installation rules
Intel AX210 Wi-Fi card	Install in slot 1.
Thunderbolt card	Install in slot 9.
Gen 5 M.2 SSD PCIe adapter	Install in slot 8, slot 3, and slot 4.
NVIDIA ConnectX-6 Ethernet Adapter card	Do not install in slot 5.
Intel X710-DA2 Ethernet Adapter card	Do not install in slot 5.
Geforce RTX 40X0 graphics card	Do not change its original installation slot.
NVIDIA A800 graphics card	<ul style="list-style-type: none"> – Ensure that one of the following graphics cards for display is installed. <ul style="list-style-type: none"> – NVIDIA RTX 4000 Ada – NVIDIA RTX A1000 – NVIDIA RTX T1000 – If the quantity of NVIDIA A800 graphics card is 4, install them in slot 6, slot 8, slot 2, and slot 4.
Graphics card for display <ul style="list-style-type: none"> – NVIDIA RTX 4000 Ada – NVIDIA RTX A1000 – NVIDIA RTX T1000 	<ul style="list-style-type: none"> – Ensure that at least one NVIDIA A800 graphics card is installed. – If the quantity of NVIDIA A800 graphics card is 1, 2, or 3, install the graphics card for display in slot 6. – If the quantity of NVIDIA A800 graphics card is 4, install the graphics card for display in slot 1.
BMC card (for selected models)	<ul style="list-style-type: none"> – Install in slot 8. – Ensure that at least one graphics card is installed.

Cable connection

Note: The connectors on the cards or system board might look slightly different from the illustrations.

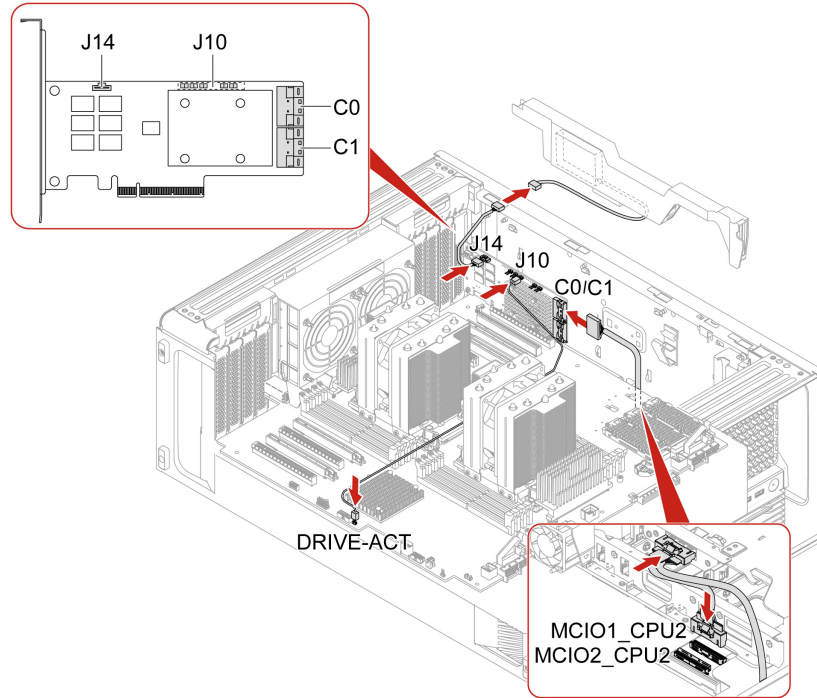

Notes:

- C0 connector priority is higher than C1 connector.
- MCI0 connector 1 priority is higher than MCI0 connector 2.
- Front access bay 2+5 priority is higher than front access bay 3+6 .

Figure 3. Cable connection for BCM9560 RAID AIC

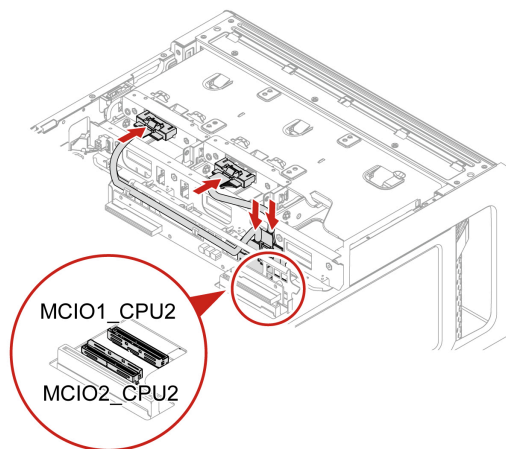

Notes:

- MCI0 connector 1 priority is higher than MCI0 connector 2.
- Front access bay 2+5 priority is higher than front access bay 3+6.

Figure 4. Cable connection for M.2 SSD enclosure

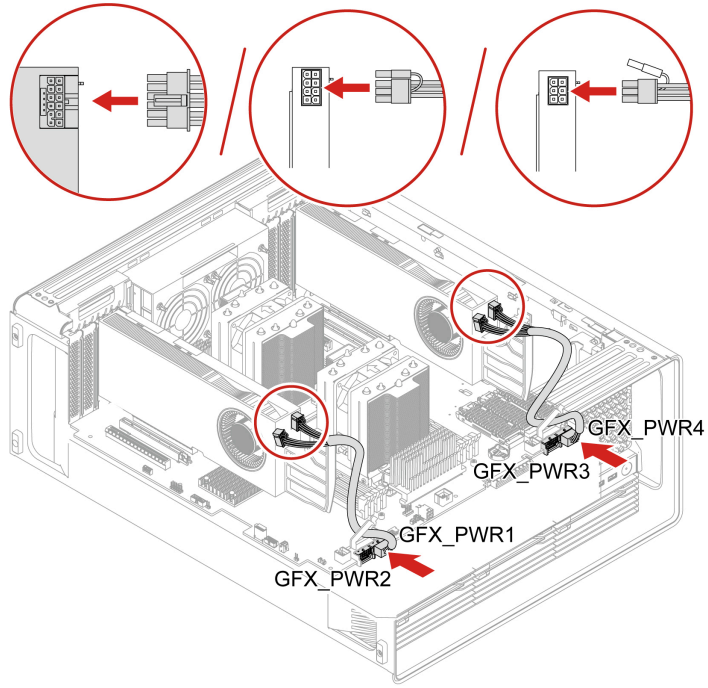

Figure 5. GTX GV100/RTX A5500/RTX A4500/RTX 5000 Ada/RTX 4500 Ada/RTX 4000 Ada Aux power connection

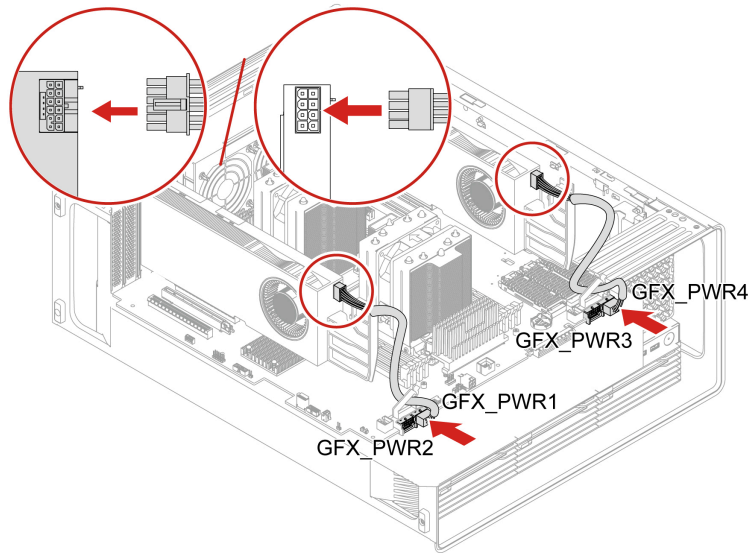
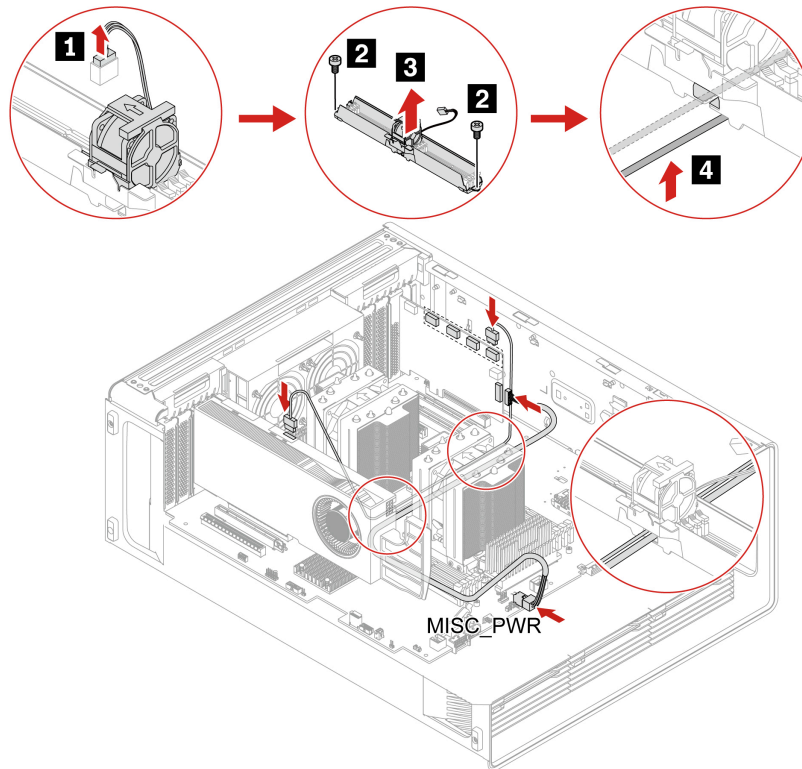

Figure 6. GTX RTX A6000/RTX 6000 Ada Aux power connection



Note: When the NVIDIA Quadro SYNC II card and the graphics card are located in the upper PCIe card area and lower PCIe card area respectively, ensure that you remove the memory fan duct to route the SYNC II card cable and power cable through the cable slot of the memory fan duct as illustrated above.

Figure 7. Cable connection for NVIDIA Quadro SYNC II card

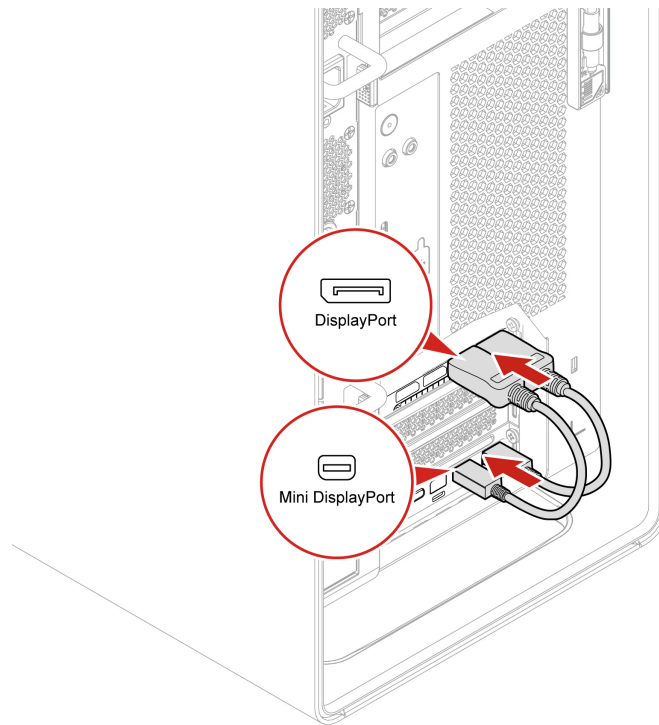

Figure 8. Cable connection for Thunderbolt card

Lock kit for the front access bay

Before you start, ensure that you have read “Prerequisites for hardware replacement” on page 34.

Removal steps

1. Remove the following parts, if any:
 - a. “Left side cover” on page 39
 - b. “CPU duct” on page 47
 - c. “Front fan assembly” on page 48
 - d. “Front fan bracket” on page 49
2. Remove the front access bay lock.

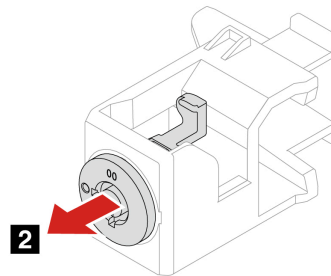
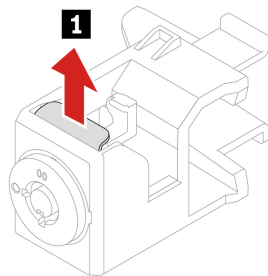
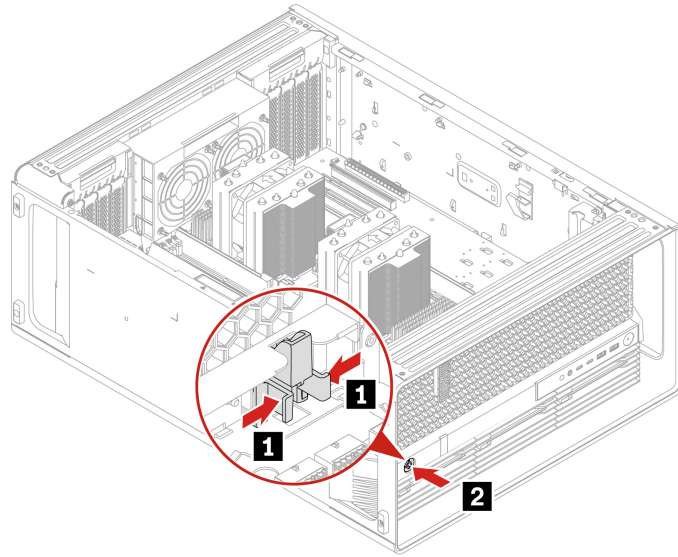

Installation steps

Install the front access bay lock.

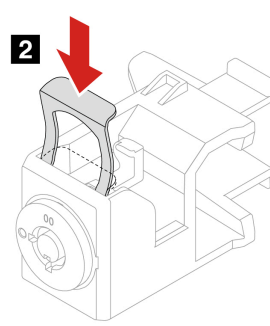
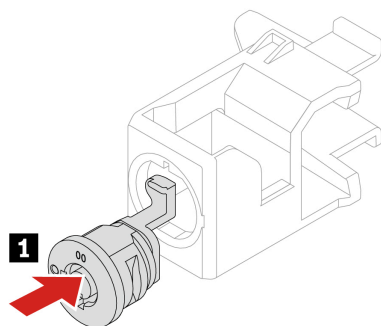

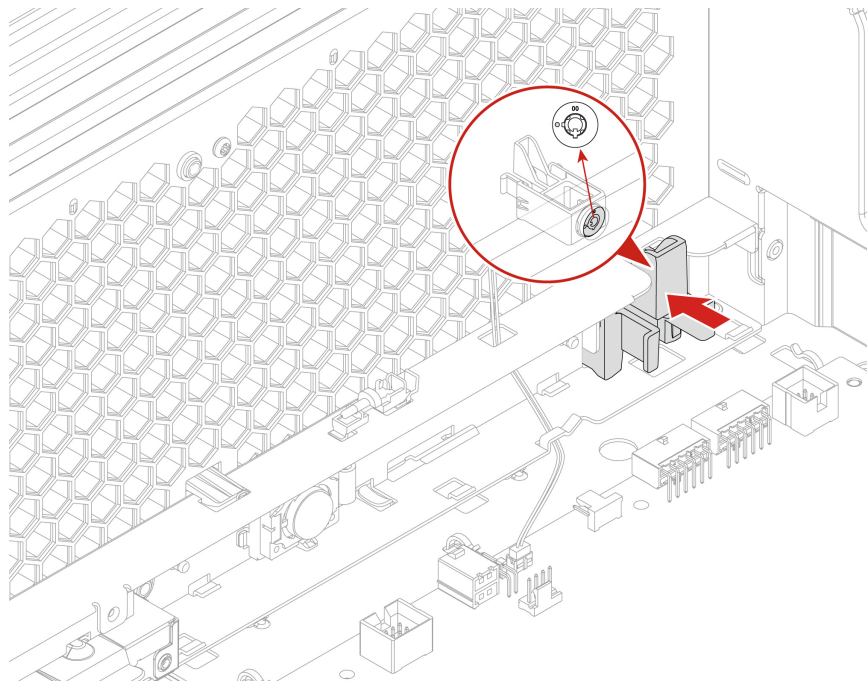

Memory module

- Before you start, ensure that you have read “Prerequisites for hardware replacement” on page 34.
- To remove or install the memory module, wait for several seconds after disconnecting power cords from the system according to the following table. It allows the system to be completely discharged of electricity.

Power supply assembly status	Waiting time
Removed	15 seconds
Installed	30 seconds

- Ensure that you follow the installation order for memory modules shown in the following illustration.
 - **1 CPU**

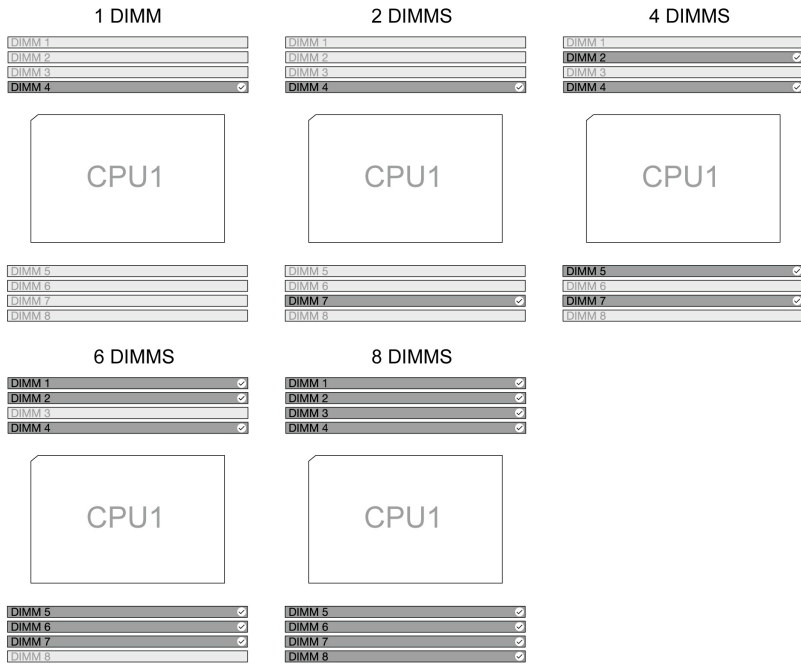

- 2 CPUs

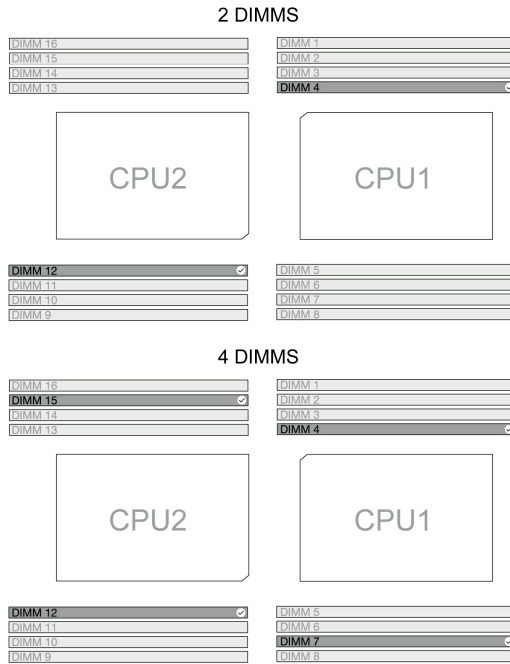

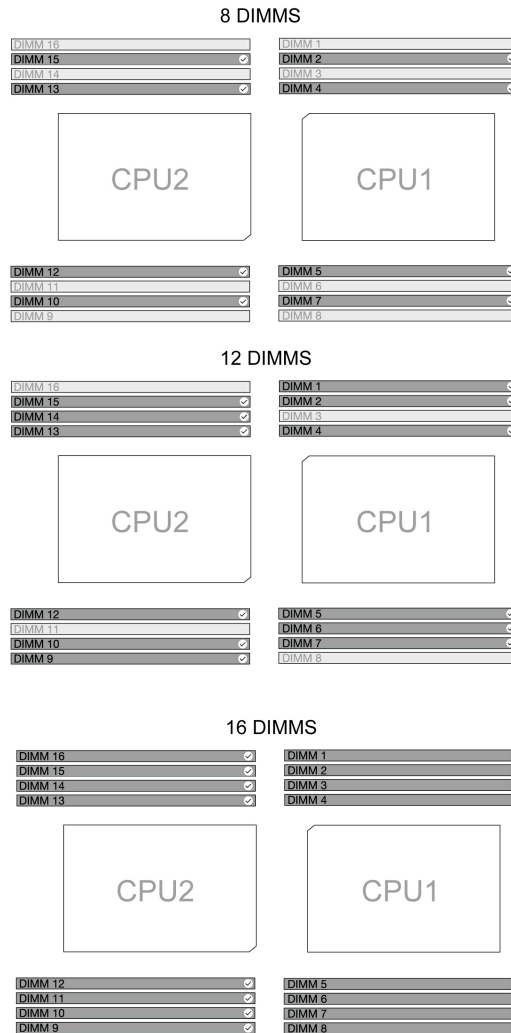

Removal steps

1. Remove the following parts, if any:
 - a. “Left side cover” on page 39
 - b. “CPU duct” on page 47
 - c. “Front fan assembly” on page 48
 - d. “Front fan bracket” on page 49
 - e. “Rear fan assembly” on page 50
 - f. “Memory fan” on page 51
2. Remove the memory module.

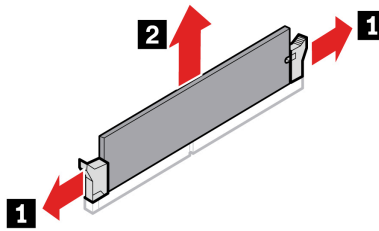

Installation steps

Install the memory module.

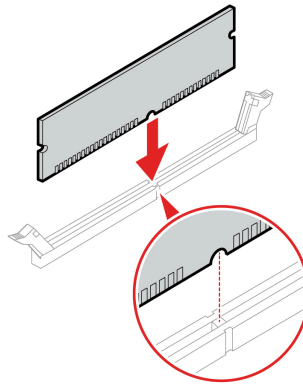

Front panel IO assembly

Before you start, ensure that you have read “Prerequisites for hardware replacement” on page 34.

Removal steps

1. Remove the following parts, if any:
 - a. “Left side cover” on page 39
 - b. “CPU duct” on page 47
 - c. “Front fan assembly” on page 48
 - d. “Front fan bracket” on page 49
2. Remove the front panel IO assembly.

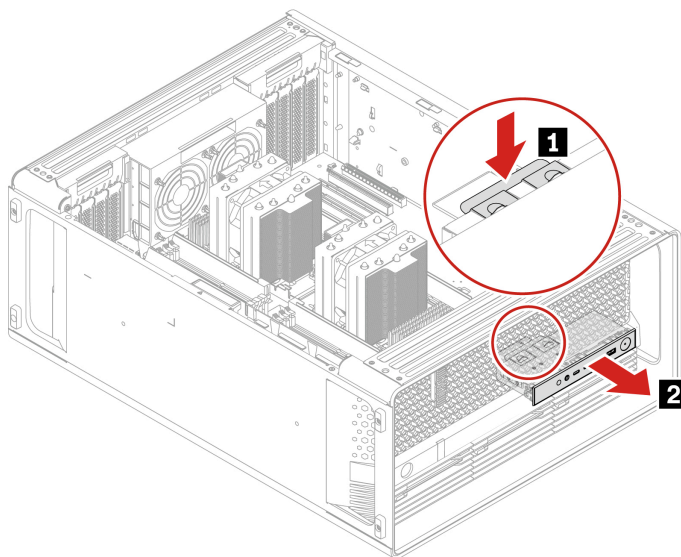

Think LED holder and cable

Before you start, ensure that you have read “Prerequisites for hardware replacement” on page 34.

Removal steps

1. Remove the following parts, if any:
 - a. “Left side cover” on page 39
 - b. “CPU duct” on page 47
 - c. “Front fan assembly” on page 48
 - d. “Front fan bracket” on page 49
2. Remove the Think LED holder and cable.

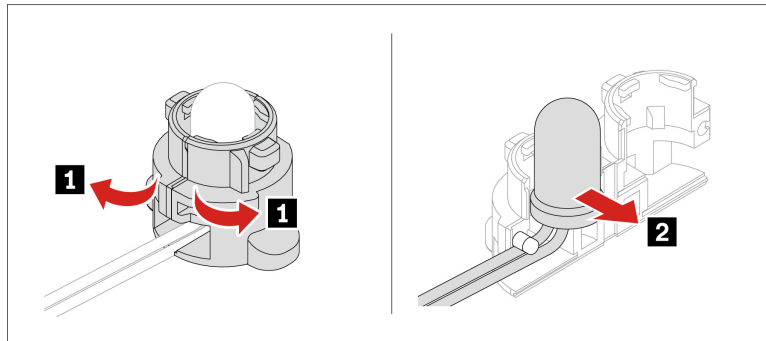
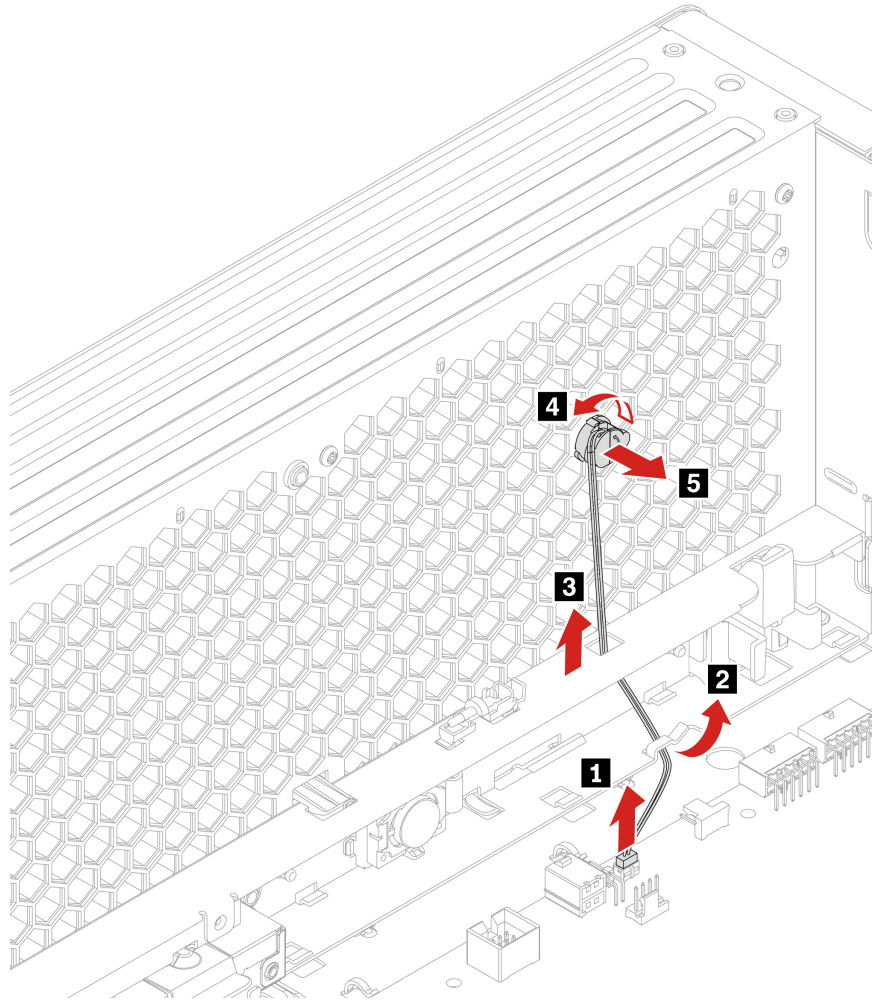

Power distribution board and bracket

Before you start, ensure that you have read “Prerequisites for hardware replacement” on page 34.

Removal steps

1. Remove the following parts, if any:
 - a. “Power supply assembly” on page 37

- b. “Left side cover” on page 39
 - c. “Right side cover” on page 44
 - d. “HDD in the PSU bay storage enclosure” on page 54
2. Loosen the three screws to remove the power distribution board and bracket.

Note: The three screws cannot be removed from the power distribution board bracket.

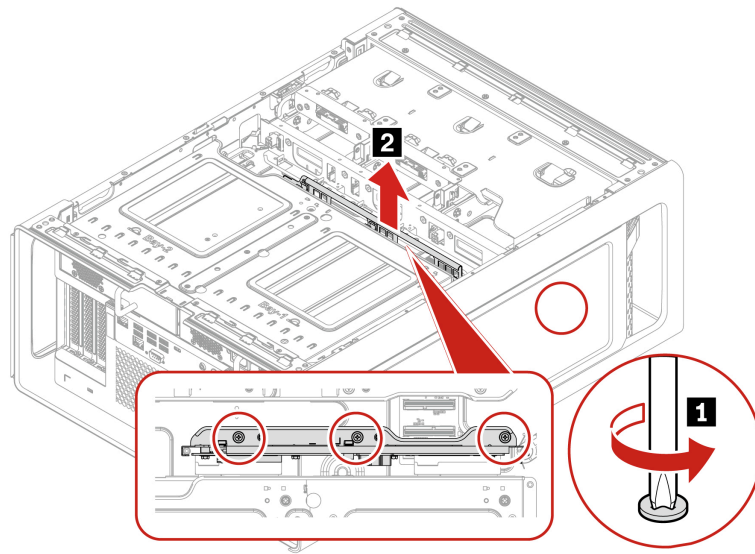

Screw (quantity)	Color	Torque
6-32*3.8 mm, Zn coated (3)	Blue	3.0 ± 0.5 lb/in

BCB board and bracket

Before you start, ensure that you have read “Prerequisites for hardware replacement” on page 34.

Removal steps

1. Remove the following parts, if any:
 - a. “HDD in the front access bay” on page 52 and “M.2 SSD in the front access bay” on page 56
 - b. “Left side cover” on page 39
 - c. “Right side cover” on page 44
 - d. “Storage fan assembly” on page 51
2. Loosen the three screws to remove the BCB board and bracket.

Note: The three screws cannot be removed from the BCB board bracket.

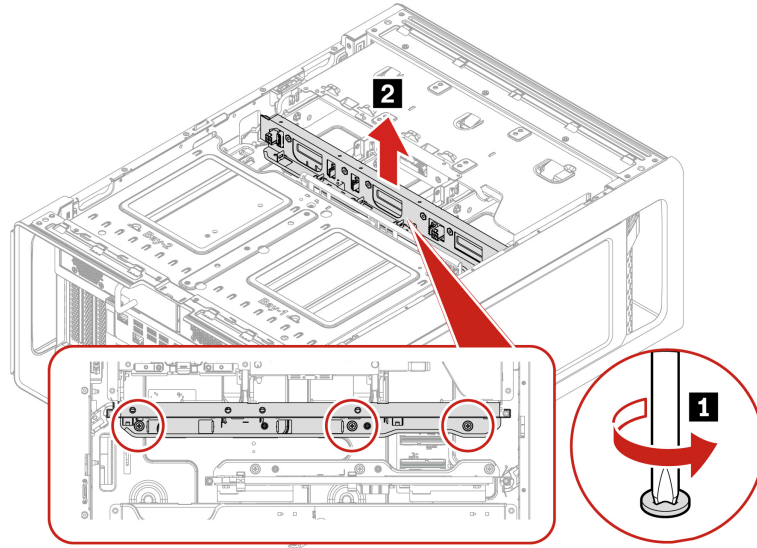

Screw (quantity)	Color	Torque
6-32*3.8 mm, Zn coated (3)	Blue	3.0 ± 0.5 lb/in

Chapter 5. Help and support

Self-help resources

Use the following self-help resources to learn more about the computer and troubleshoot problems.

Resources	How to access?
Product documentation: <ul style="list-style-type: none">• <i>Safety and Warranty Guide</i>• <i>Generic Safety and Compliance Notices</i>• <i>Setup Guide</i>• <i>This User Guide</i>• <i>Regulatory Notice</i>	Go to https://support.lenovo.com/documentation and search by product.
Lenovo Support Web site with the latest support information of the following: <ul style="list-style-type: none">• Drivers and software• Diagnostic solutions• Product and service warranty• Product and parts details• Knowledge base and frequently asked questions	https://pcsupport.lenovo.com
Ubuntu help information	https://help.ubuntu.com/its/ubuntu-help/index.html
IGEL support information	https://support.igel.com/

Lenovo diagnostic tools

For information about Lenovo diagnostic tools, go to:
<https://pcsupport.lenovo.com/lenovodiagnosicsolutions>

Call Lenovo

If you have tried to correct the problem yourself and still need help, you can call Lenovo Customer Support Center.

Before you contact Lenovo

Prepare the following before you contact Lenovo:

1. Record the problem symptoms and details:
 - What is the problem? Is it continuous or intermittent?
 - Any error message or error code?
 - What operating system are you using? Which version?
 - Which software applications were running at the time of the problem?
 - Can the problem be reproduced? If so, how?
2. Record the system information:
 - Product name

- Machine type and serial number

The following illustration shows where to find the machine type and serial number of your computer.

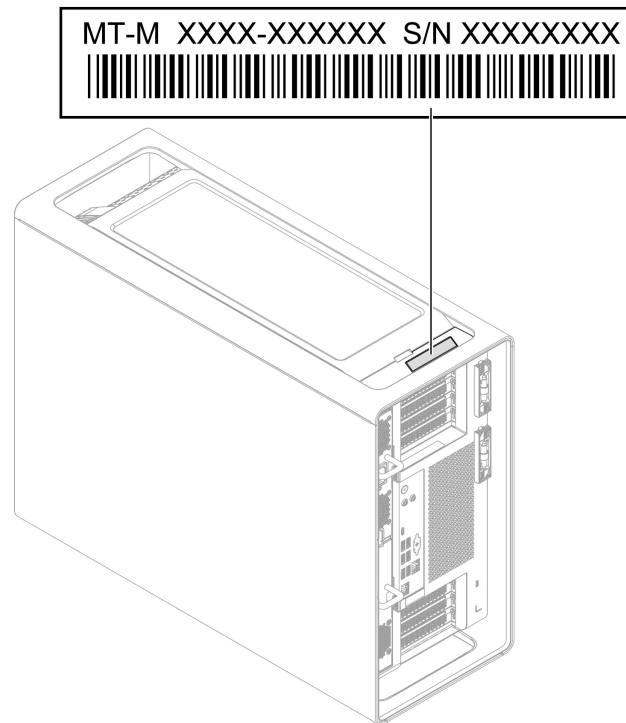

Lenovo Customer Support Center

During the warranty period, you can call Lenovo Customer Support Center for help.

Telephone numbers

For a list of the Lenovo Support phone numbers for your country or region, go to:

<https://pcsupport.lenovo.com/supportphonenumberlist>

Note: Phone numbers are subject to change without notice. If the number for your country or region is not provided, contact your Lenovo reseller or Lenovo marketing representative.

Certification-related information

Product name: ThinkStation PX

Machine types: 30EU, 30EV, and 30EY

Further compliance information related to your product is available at <https://www.lenovo.com/compliance>.

Compliance information

For more compliance information, refer to *Regulatory Notice* at https://support.lenovo.com/docs/common_commercial_rn and *Generic Safety and Compliance Notices* at https://pcsupport.lenovo.com/docs/generic_notices.

Purchase additional services

During and after the warranty period, you can purchase additional services from Lenovo at: <https://pcsupport.lenovo.com/warrantyupgrade>

Service availability and service name might vary by country or region.

Purchase accessories

Lenovo has a number of hardware accessories and upgrades to help expand the capabilities of your computer. Options include memory modules, storage devices, network cards, power adapters, keyboards, mice, and more.

To shop at Lenovo, go to <https://www.lenovo.com/accessories>.

Accessibility features

Lenovo is committed to making information technology accessible to everyone, including individuals with hearing, vision, mobility, cognitive, or speech disabilities. To get the most up-to-date and detailed accessibility features information for the product, go to https://support.lenovo.com/docs/product_accessibility_features.

Appendix A. Supplemental information about the Ubuntu operating system

In limited countries or regions, Lenovo offers customers an option to order computers with the preinstalled Ubuntu® operating system.

If the Ubuntu operating system is available on your computer, read the following information before you use the computer. Ignore any information related to Windows-based programs, utilities, and Lenovo preinstalled applications in this documentation.

Access the Lenovo Limited Warranty

This product is covered by the terms of the Lenovo Limited Warranty (LLW), version L505-0010-02 08/2011. You can view the LLW in a number of languages from the following Web site. Read the Lenovo Limited Warranty at:

https://www.lenovo.com/warranty/llw_02

The LLW also is preinstalled on the computer. To access the LLW, go to the following directory:

```
/opt/Lenovo
```

If you cannot view the LLW either from the Web site or from your computer, contact your local Lenovo office or reseller to obtain a printed version of the LLW.

Access the Ubuntu help system

The Ubuntu help system provides information about how to use the Ubuntu operating system. To access the help system from Home Screen, move your pointer to the Launch bar, and then click the **Help** icon. If you cannot find the **Help** icon from the Launch bar, click the **Search** icon on the bottom left, and type Help to search it.

To learn more about the Ubuntu operating system, go to:

<https://www.ubuntu.com>

Access IGEL distributions

To learn more about the IGEL operating system, go to <https://www.igel.com/support>.

Get support information

If you need help, service, technical assistance, or more information about the Ubuntu operating system or other applications, contact the provider of the Ubuntu operating system or the provider of the application. If you need the service and support for hardware components shipped with your computer, contact Lenovo. For more information about how to contact Lenovo, refer to the *User Guide* and *Safety and Warranty Guide*.

To access the latest *User Guide* and *Safety and Warranty Guide*, go to:

<https://pcsupport.lenovo.com>

Access open-source information

This device includes software made publicly available by Lenovo, including software licensed under the General Public License and/or the Lesser General Public License (the open source software).

You may obtain a copy of the corresponding source code for any such open source software licensed under the General Public License and/or the Lesser General Public License (or any other license requiring us to

make a written offer to provide corresponding source code to you) from Lenovo for a period of three years without charge except for the cost of media, shipping, and handling, upon written request to Lenovo. This offer is valid to anyone in receipt of this device.

You may send your request in writing to the address below accompanied by a check or money order for \$15 to:

Lenovo Legal Department
Attn: Open Source Team / Source Code Requests
8001 Development Dr.
Morrisville, NC 27560

Please include the version of the OS and the version of the Linux Kernel pre-shipped on this Device as part of your request. Be sure to provide a return address.

The open source software is distributed in hope it will be useful, but WITHOUT ANY WARRANTY; without even the implied warranty of MERCHANTABILITY or FITNESS FOR A PARTICULAR PURPOSE. See for example the GNU General Public License and/or the Lesser General Public License for more information.

To view additional information regarding licenses, acknowledgments and required copyright notices for the open source software shipped on your Device, go to `/usr/share/doc/*/copyright`.

Appendix B. Important notice for Quebec consumers

In regard to section 79.18 of Quebec's Regulation respecting the application of the Consumer Protection Act, Lenovo in no way guarantees the availability of (a) replacement parts; (b) repair services; and (c) information necessary to maintain or repair the goods. For up-to-date information on the technical support and parts available for your purchase, please consult <https://support.lenovo.com/ca/en>.

En ce qui concerne l'article 79.18 du Règlement d'application de la Loi sur la protection du consommateur du Québec, Lenovo ne garantit en aucune façon la disponibilité des éléments suivants : (a) les pièces de rechange; (b) les services de réparation; et (c) les renseignements nécessaires à l'entretien à la réparation du bien. Pour obtenir des renseignements à jour sur le soutien technique et les pièces disponibles pour votre achat, veuillez consulter <https://support.lenovo.com/ca/fr>.

Appendix C. Notices and trademarks

Notices

Lenovo may not offer the products, services, or features discussed in this document in all countries. Consult your local Lenovo representative for information on the products and services currently available in your area. Any reference to a Lenovo product, program, or service is not intended to state or imply that only that Lenovo product, program, or service may be used. Any functionally equivalent product, program, or service that does not infringe any Lenovo intellectual property right may be used instead. However, it is the user's responsibility to evaluate and verify the operation of any other product, program, or service.

Lenovo may have patents or pending patent programs covering subject matter described in this document. The furnishing of this document does not give you any license to these patents. You can send license inquiries, in writing, to:

*Lenovo (United States), Inc.
8001 Development Drive
Morrisville, NC 27560
U.S.A.
Attention: Lenovo Director of Licensing*

LENOVO PROVIDES THIS PUBLICATION "AS IS" WITHOUT WARRANTY OF ANY KIND, EITHER EXPRESS OR IMPLIED, INCLUDING, BUT NOT LIMITED TO, THE IMPLIED WARRANTIES OF NON-INFRINGEMENT, MERCHANTABILITY OR FITNESS FOR A PARTICULAR PURPOSE. Some jurisdictions do not allow disclaimer of express or implied warranties in certain transactions, therefore, this statement may not apply to you.

Changes are made periodically to the information herein; these changes will be incorporated in new editions of the publication. To provide better service, Lenovo reserves the right to improve and/or modify the products and software programs described in the manuals included with your computer, and the content of the manual, at any time without additional notice.

The software interface and function and hardware configuration described in the manuals included with your computer might not match exactly the actual configuration of the computer that you purchase. For the configuration of the product, refer to the related contract (if any) or product packing list, or consult the distributor for the product sales. Lenovo may use or distribute any of the information you supply in any way it believes appropriate without incurring any obligation to you.

The products described in this document are not intended for use in implantation or other life support applications where malfunction may result in injury or death to persons. The information contained in this document does not affect or change Lenovo product specifications or warranties. Nothing in this document shall operate as an express or implied license or indemnity under the intellectual property rights of Lenovo or third parties. All information contained in this document was obtained in specific environments and is presented as an illustration. The result obtained in other operating environments may vary.

Lenovo may use or distribute any of the information you supply in any way it believes appropriate without incurring any obligation to you.

Any references in this publication to non-Lenovo Web sites are provided for convenience only and do not in any manner serve as an endorsement of those Web sites. The materials at those Web sites are not part of the materials for this Lenovo product, and use of those Web sites is at your own risk.

Any performance data contained herein was determined in a controlled environment. Therefore, the result obtained in other operating environments may vary significantly. Some measurements may have been made on development-level systems and there is no guarantee that these measurements will be the same on generally available systems. Furthermore, some measurements may have been estimated through extrapolation. Actual results may vary. Users of this document should verify the applicable data for their specific environment.

This document is copyrighted by Lenovo and is not covered by any open source license, including any Linux agreement(s) which may accompany software included with this product. Lenovo may update this document at any time without notice.

For the latest information or any questions or comments, contact or visit the Lenovo Web site:

<https://pcsupport.lenovo.com>

Trademarks

Lenovo, Lenovo logo, ThinkStation, and ThinkStation logo are trademarks of Lenovo. Intel and Thunderbolt are trademarks of Intel Corporation or its subsidiaries in the U.S. and/or other countries. Mini DisplayPort (mDP) and DisplayPort are trademarks of the Video Electronics Standards Association. Wi-Fi and Miracast are registered trademarks of Wi-Fi Alliance. USB-C is a registered trademark of USB Implementers Forum. All other trademarks are the property of their respective owners.

Lenovo