

Linux User Guide

Lenovo
ThinkStation



Lenovo

ThinkStation P3 Ultra SFF G2

Third Edition (March 2026)

© Copyright Lenovo 2025, 2026.

LIMITED AND RESTRICTED RIGHTS NOTICE: If data or software is delivered pursuant to a General Services Administration "GSA" contract, use, reproduction, or disclosure is subject to restrictions set forth in Contract No. GS-35F-05925.

Contents

Chapter 1. Overview 1

Front	1
Rear	3
Specifications	3
USB specifications	5

Chapter 2. Get started. 7

Initial setup	7
Connect to an external display	7
Get started with Ubuntu Desktop (24.04 LTS)	7
Access networks	7
Connect to a Bluetooth-enabled device (24.04 LTS) (for selected models).	8
Set the power plan	9
Smart power-on feature (for selected models)	9

Chapter 3. Features 10

Expand your computer	10
Security solutions	11
Use physical locks	11
Use BIOS security solutions	11
UEFI BIOS passwords	13

Chapter 4. UEFI BIOS 15

Enter the UEFI BIOS menu	15
Navigate the UEFI BIOS menu	15
Update the UEFI BIOS	15
Using the built-in software update service.	16
From the Lenovo Support Web site	16

Chapter 5. CRU replacement 17

Before CRU replacement	17
What is CRU	17
CRU list	17
System board illustration	18

Prerequisites for hardware replacement	20
Power adapter and power cord.	20
Dust filter	21
Chassis	22
M.2 solid-state drive thermal kit	23
M.2 solid-state drive	25
Hard disk drive fan.	30
3.5-inch hard disk drive bracket kit	30
3.5-inch hard disk drive.	31
LED cable and holder	32
Memory module	33
PCI-Express bracket	35
PCI-Express card (including graphics card)	36
PCI-Express card converter	38

Chapter 6. Help and support 41

Find your serial number.	41
Lenovo diagnostic tools	41
Call Lenovo	41
Before you contact Lenovo	41
Lenovo Customer Support Center	42
Self-help resources	42
Purchase accessories or additional services	42
Accessibility features.	43
Supplemental information about the Ubuntu operating system	43

Appendix A. Important notice for Quebec consumers 45

Appendix B. Notice for USB connector name update 46

Appendix C. Notices and trademarks. 47

About this documentation

This documentation applies to the ThinkStation® product models listed below.

Model name	Machine types (MT)
ThinkStation P3 Ultra SFF G2	30J5, 30J6, 30J8, 30J9, 30JA, 30J3, 30J4, 30JC

Further compliance information related to your product is available at <https://www.lenovo.com/compliance>.

Before using this documentation, please read the following information:

- *Setup Guide*
- *Safety and Warranty Guide*
- For more compliance information, refer to *Regulatory Notice* at <https://pcsupport.lenovo.com> and *Generic Safety and Compliance Notices* at https://pcsupport.lenovo.com/docs/generic_notices.
- Illustrations in this documentation might look different from your product.
- Depending on the model, some optional accessories, features, software programs, and user interface instructions might not be applicable to your computer.
- Documentation content is subject to change without notice. To get the latest documentation, go to <https://pcsupport.lenovo.com>.

Chapter 1. Overview

Front

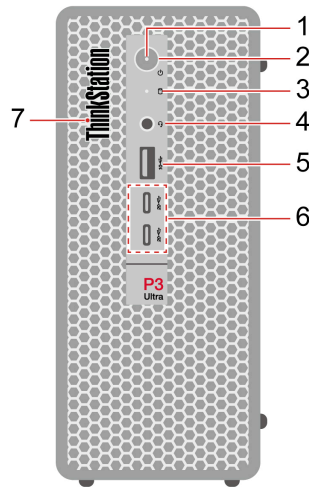

Item	Description	Item	Description
1	Power indicator	2	Power button
3	Storage drive activity indicator	4	Headset connector
5	USB-A connector (USB 10Gbps)	6	USB-C® connectors (USB 20Gbps)
7	ThinkStation LED		

Statement on USB transfer rate

Depending on many factors such as the processing capability of the host and peripheral devices, file attributes, and other factors related to system configuration and operating environments, the actual transfer rate using the various USB connectors on this device will vary and will be slower than the data rate listed in the connector name or below for each corresponding device.

USB device	Data rate (Gbit/s)
Thunderbolt 3	40
Thunderbolt 4	40

Power indicator

Show the system status of your computer.

- **On:** The computer is starting up or working.
- **Off:** The computer is off or in hibernation mode.
- **Blinking:** The computer is in sleep mode.

Headset connector

The headset connector is compatible with:

- Headphones or earphones with a 3.5mm (0.14 inch), TRS (3-pole) plug
- Headsets with a 3.5mm (0.14 inch), CTIA-compliant TRRS (4-pole) plug

Note: This headset connector does not support standalone external microphones with a TRS (3-pole) plug or headsets with an OMTP-compliant TRRS (4-pole) plug.

Related topics

- “USB specifications” on page 5.
- “Connect to a Bluetooth-enabled device” on page .

Rear

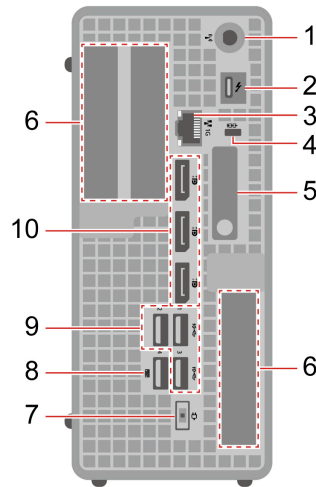



Item	Description	Item	Description
1	Wi-Fi® antenna slot	2	USB-C connector (Thunderbolt™ 4)*
3	Ethernet connector (1 GbE)	4	Security-lock slot
5	Chassis latch	6	PCI-Express card area
7	Power cord connector	8	USB-A connector (USB 10Gbps, smart power on)
9	USB-A connector (USB 10Gbps)	10	DisplayPort™ out connectors

Related topics

- “USB specifications” on page 5.
- “Use physical locks” on page 11.
- “” on page .
- “Smart power-on feature (for selected models)” on page 9.

Specifications

Specification	Description
Dimensions	<ul style="list-style-type: none"> • Width: 87 mm (3.43 inches) • Height: 202 mm (7.95 inches) • Depth: 223 mm (8.78 inches)
Weight (without packaging)	Maximum configuration as shipped: 3.5 kg (7.72 lb)
Hardware configuration	<ol style="list-style-type: none"> 1. Open the system menu from the top-right corner and click . 2. Click System → About.

Specification	Description
Power supply	<ul style="list-style-type: none"> • 170-watt automatic voltage-sensing power supply • 230-watt automatic voltage-sensing power supply • 245-watt automatic voltage-sensing power supply • 330-watt automatic voltage-sensing power supply
Electrical input	<ul style="list-style-type: none"> • Input voltage: From 100 V ac to 240 V ac • Input frequency: 50/60 Hz
Microprocessor	<p>To view the microprocessor information of your computer:</p> <ol style="list-style-type: none"> 1. Open the system menu from the top-right corner and click . 2. Click System → About.
Memory	<p>Up to two double data rate 5 (DDR5) small outline dual in-line memory module (SODIMM)</p> <p>Maximum memory capacity: 128 GB</p>
Storage device	<ul style="list-style-type: none"> • 3.5-inch hard disk drive* • On-board M.2 solid-state drive* • PCI-Express M.2 solid-state drive* <p>Type Disks in the search box and use the Disks application to view the storage drive capacity of your computer.</p> <p>Note: The storage drive capacity indicated by the system is less than the nominal capacity.</p>
Video features	<ul style="list-style-type: none"> • The integrated graphics card supports the following: <ul style="list-style-type: none"> – DisplayPort out connector – USB-C connector (Thunderbolt 4) • The optional discrete graphics card provides an enhanced video experience and extended capabilities.
Expansion	<ul style="list-style-type: none"> • Memory slots • M.2 solid-state drive slot • Storage drive bay • PCI Express slots
Network features	<ul style="list-style-type: none"> • Bluetooth* • Ethernet LAN • Wireless LAN*

* for selected models

Operating environment

Maximum altitude (without pressurization)

- Operating: From 0 m (0 ft) to 3048 m (10 000 ft)
- Storage: From 0 m (0 ft) to 12192 m (40 000 ft)

Temperature

- Operating: From 10°C (50°F) to 35°C (95°F)
- Storage: From -40°C (-40°F) to 60°C (140°F)

Relative humidity

- Operating: 20%-80% (non-condensing)
- Storage: 10%–90% (non-condensing)

System memory speed

Your computer can come with the following types of memory modules and will run up to the following speed:

Memory module type	Memory module speed
DDR5 ECC 6400 SoDIMMs	6400 MT/s
DDR5 non-ECC 6400 SoDIMMs	
DDR5 ECC 5600 SoDIMMs	5600 MT/s
DDR5 non-ECC 5600 SoDIMMs	

Notes:

- The actual system memory speed of the memory modules varies depending on the microprocessor model. For example, your computer comes with 4800 MT/s memory modules, but the microprocessor only supports up to 4000 MT/s memory modules. Then the system memory speed will be no faster than 4000 MT/s.
- The microprocessor models supported in your computer might vary. For a list of supported microprocessor models, contact the Lenovo Customer Support Center.
- The ECC memory modules are not supported on the computer models with Intel Ultra 5 225T or Intel Ultra 5 225 microprocessors.

USB specifications

Note: Depending on the model, some USB connectors might not be available on your computer.

Connector name	Description
----------------	-------------

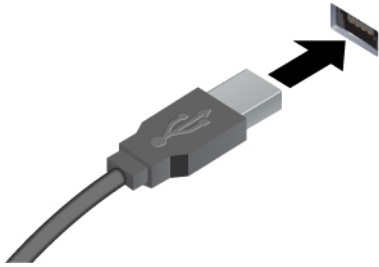

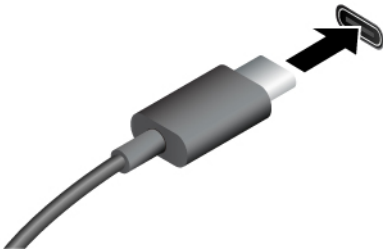

Connect USB-A compatible devices, such as a USB-A keyboard, USB-A mouse, USB-A storage device, or USB-A printer.

-  USB-A connector (USB 10Gbps)



- Charge USB-C compatible devices with the output voltage and current of 5 V and 3 A.
- Connect to USB-C accessories to help expand your computer functionality. To purchase USB-C accessories, go to <https://www.lenovo.com/accessories>.

-  USB-C connector (USB 20Gbps)
-  USB-C connector (Thunderbolt 4)

Chapter 2. Get started

Initial setup

This section helps you set up your computer.

1. Connect the cables of external displays to appropriate connectors on the graphics card installed in the computer.
 2. Connect the mouse and the keyboard to the computer respectively.
 3. Connect the cables of other devices according to the devices' instructions.
 4. Connect the power cord to the power adapter. Then connect the power cord to the power cord connector on the computer and connect it to a properly-grounded electrical outlet.
 5. Press the power button to turn on the computer.
 6. Follow the on-screen instructions to complete the setup procedures.
-

Connect to an external display

Connect a projector or a monitor to your computer to give presentations or expand your workspace.

Connect to a wired display

1. Connect the external display to an appropriate video connector on your computer.
2. Connect the external display to an electrical outlet.
3. Turn on the external display.

Change display settings

1. Right-click a blank area on the desktop and select display settings.
 2. Select the display that you want to configure and change display settings of your preference.
-

Get started with Ubuntu Desktop (24.04 LTS)

Learn the basics of Ubuntu and start working with it right away. For more information about Ubuntu, see the Ubuntu documentation site at: <https://help.ubuntu.com/lts/ubuntu-help/index.html>.

The Gnome desktop is installed by default and is designed to be simple and easy to use. Details on using Gnome are available by launching the Help application or online at <https://help.gnome.org/users/>.

Launch an app

- Press the Super key (with the Windows logo) or open the Activities menu on the top left and type in the name of the application you want to launch.
- Click the **Show Apps** button on the lower left, and select the application you want to launch.

Launch settings

Open the system menu from the top-right corner and click .

Access networks

This section helps you access networks through connecting to a wireless or wired network.

Connect to Wi-Fi networks (for selected models)

If your computer includes a wireless LAN module, you can connect your computer to Wi-Fi® networks.

1. Open the system menu from the top-right corner and turn on the Wi-Fi by clicking **Wi-Fi** button.
2. Click **>** to expand the Wi-Fi section of the menu. A list of available wireless networks is displayed. Click **All Networks** to see extra options.
3. Select an available network for connection. Provide required information if needed.

Note: The wireless LAN module on your computer may support different standards. For some countries or regions, the use of 802.11ax and 802.11be may be disabled according to local regulations.

Connect to the wired Ethernet

Connect your computer to a local network through the Ethernet connector on your computer with an Ethernet cable.

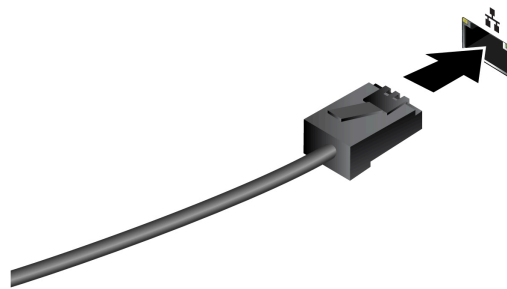

Note: For models with an Intel X710-T2L Ethernet adapter, it's recommended to prepare a Shielded Twisted Pair (STP) Category 6A Ethernet cable for Ethernet connection on the adapter.

Connect to a Bluetooth-enabled device (24.04 LTS) (for selected models)

You can connect all types of Bluetooth-enabled devices to your computer, such as a keyboard, a mouse, a smartphone, or speakers. Place the device that you are attempting to connect to less than 10 meters (33 feet) from the computer.



1. Open the system menu from the top-right corner and turn on the Bluetooth by clicking **Bluetooth** button.
2. Click > to expand the Bluetooth section of the menu. A list of discoverable devices is displayed.
3. Select a Bluetooth device, and then follow the on-screen instructions.

Your Bluetooth-enabled device and computer will automatically connect the next time if the two devices are in range of each other with Bluetooth turned on. You can use Bluetooth for data transfer or remote control and communication.

Set the power plan

For ENERGY STAR® compliant computers, the following power plan takes effect when your computers have been idle for a specified duration:

- Turn off the display: After 5 minutes
- Put the computer to sleep: After 20 minutes

To awaken the computer from Sleep mode, press any key on your keyboard.

To set the power plan:

1. Go to **Settings → Power**.
2. Choose or customize a power plan of your preference.

Smart power-on feature (for selected models)

The smart power-on feature helps you start up or wake up the computer from the hibernation mode simply by pressing Alt+P.

Note: Ensure that the keyboard is connected to a USB connector supporting the smart power-on feature.

Enable or disable the smart power-on feature

To enable or disable the smart power-on feature:

- Step 1. Restart the computer. When the logo screen is displayed, press F1 or Fn+F1.
- Step 2. Select **Power → Smart Power On** and press Enter.
- Step 3. Enable or disable the feature as desired.
- Step 4. Press F10 or Fn+F10 to save the changes and exit.

Chapter 3. Features

Expand your computer

You can enhance your computer capacity and performance by adding various devices according to the following rules:

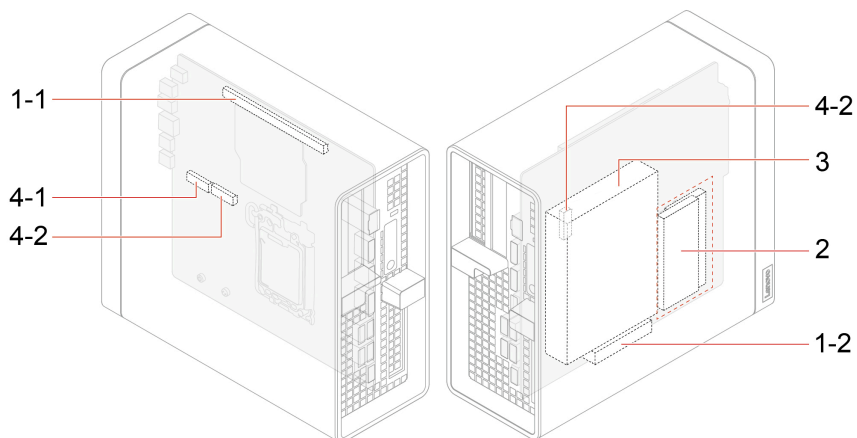

Item	Description	Expansion
1-1	Gen 4 PCI-Express x16 slot	<p>You can install the following compatible PCI-Express cards in the PCI-Express cards slots:</p> <ul style="list-style-type: none"> • DisplayPort graphics card (2-port) • Mini-DisplayPort graphics card (4-port) • USB-C connector (USB 20Gbps) expansion card (1-port) • USB-C connector (USB 5Gbps) expansion card (2-port) • USB-C connector (USB 10Gbps) expansion card (2-port) • Ethernet expansion card (2-port or 4-port) • Serial expansion card (4-port) • Baseboard Management Controller (BMC) card
1-2	Gen 3 PCI-Express x4 slot (physical link width x8; negotiable link width x4)	
2	Memory slots	You can install up to two memory cards in the memory slots.
3	Storage drive bay*	You can install one 3.5-inch hard disk drive in the storage drive bay.

Item	Description	Expansion
4-1	Gen 5 M.2 solid-state drive slot	You can install one Gen 5 M.2 solid-state drive in the M.2 solid-state drive slots.
4-2	Gen 4 M.2 solid-state drive slots	You can install up to two Gen 4 M.2 solid-state drives in the M.2 solid-state drive slots.

* for selected models

Related topics

- “PCI-Express card (including graphics card)” on page 36
- “Memory module” on page 33
- “3.5-inch hard disk drive” on page 31
- “M.2 solid-state drive” on page 25

Security solutions

Lenovo values your information security. Your computer can be secured by physical locks, software solutions, and BIOS solutions. They can protect your computer from harm, theft, or unauthorized use.

Use physical locks

Note: Lenovo makes no comments, judgments, or warranties about the function, quality, or performance of the locking device and security feature. You can purchase computer locks from Lenovo.

MicroSaver® lock

Lock your computer to a desk, table, or other fixtures through a MicroSaver lock.

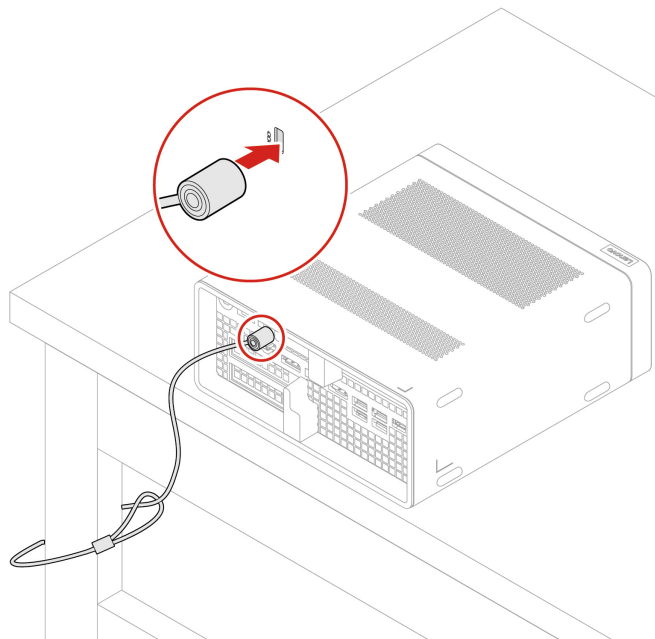

Use BIOS security solutions

This section provides BIOS solutions to secure your computer and information.

Wipe the storage drive data (for selected models)

It is recommended that you wipe the storage drive data before recycling the storage drive or the computer.

To wipe the storage drive data:

1. Restart the computer. When the logo screen is displayed, press F1 or Fn+F1.
2. Select **Security** → **secure wipe** → **Enabled**.
3. Press F10 or Fn+F10 to save the changes and exit.
4. Restart the computer. When the logo screen is displayed, press F12 or Fn+F12.
5. Select **App Menu** → **secure wipe** and press Enter.
6. Select the storage drive you will wipe and click **NEXT**.
7. Select the entire storage drive or partition to wipe as desired.
8. Select the method as desired and click **NEXT**.
9. Click **Yes** to confirm your option when the prompting window is displayed.
10. If you have set a hard disk password for the storage drive, enter the password. Otherwise, set a temporary password following the on-screen instructions. Then, click **NEXT**. The wiping process begins.

Note: Duration of the wiping process varies depending on the storage drive capacity.

11. Click **Reboot** when you are prompted to reset the system, and then one of the following will happen:
 - If the system storage drive data is wiped, you will be prompted that no operating system is found.
 - If the non-system storage drive data is wiped, the computer restarts automatically.

Cover presence switch

The cover presence switch prevents the computer from logging in to the operating system when the computer cover is not properly installed or closed.

To enable or disable the cover presence switch connector on the system board:

1. Restart the computer. When the logo screen is displayed, press F1 or Fn+F1.
2. Select **Security** → **Cover Tamper Detected** and press Enter.
3. Select **Enabled** or **Disabled** and press Enter.
4. Press F10 or Fn+F10 to save the changes and exit.

If the cover presence switch is enabled and the computer cover is not correctly installed or closed, an error message will be displayed when you turn on the computer. To bypass the error message and log in to the operating system, properly install and close the computer cover, and then enable the cover presence switch connector again in the BIOS menu.

Intel BIOS guard

The Intel® BIOS Guard module cryptographically verifies all BIOS updates. This hardware-based security helps prevent software and malware attacks on the computers BIOS.

Smart USB Protection

The Smart USB Protection function is a security function that helps prevent data from being copied from the computer to USB storage devices connected to the computer. You can set the Smart USB Protection function to one of the following modes:

- **Disabled** (default setting): You can use the USB storage devices without limitation.
- **Read Only**: You cannot copy data from the computer to the USB storage devices. However, you can access data on the USB storage devices.

- **No Access:** You cannot access the USB storage devices from the computer.

To configure the Smart USB Protection function:

1. Restart the computer. When the logo screen is displayed, press F1 or Fn+F1.
2. Select **Security → Smart USB Protection** and press Enter.
3. Select the desired setting and press Enter.
4. Press F10 or Fn+F10 to save the changes and exit.

Absolute Persistence (for computers purchased outside mainland China)

Absolute Persistence technology is embedded in BIOS. It detects changes that happen on the hardware, software, or the call-in location. It keeps you always knowing what condition the computer is in. To activate the technology, you have to purchase a subscription to Absolute.

UEFI BIOS passwords

You can set passwords in UEFI (Unified Extensible Firmware Interface) BIOS (Basic Input/Output System) to strengthen the security of your computer.

Password types

You can set a power-on password, supervisor password, system management password, or hard disk password in UEFI BIOS to prevent unauthorized access to your computer. However, you are not prompted to enter any UEFI BIOS password when your computer resumes from sleep mode.

- Power-on password

When a power-on password is set, you are prompted to enter a valid password each time the computer is turned on.

- Supervisor password

Setting a supervisor password deters unauthorized users from changing configuration settings. If you are responsible for maintaining the configuration settings of several computers, you might want to set a supervisor password.

When a supervisor password is set, you are prompted to enter a valid password each time you try to enter the BIOS menu.

If both the power-on password and supervisor password are set, you can enter either password. However, you must use your supervisor password to change any configuration settings.

- Hard disk password (for selected models)

Setting a hard disk password prevents unauthorized access to the data on the storage drive. When a hard disk password is set, you are prompted to enter a valid password each time you try to access the storage drive.

Note: After you set a hard disk password, your data on the storage drive is protected even if the storage drive is removed from one computer and installed in another.

- System management password (for selected models)

You can enable the system management password to have the same authority as the supervisor password to control security related features. To customize the authority of the system management password through the UEFI BIOS menu:

1. Restart the computer. When the logo screen is displayed, press F1 or Fn+F1.
2. Select **Security → System Management Password Access Control**.
3. Follow the on-screen instructions.

If you have set both the supervisor password and the system management password, the supervisor password overrides the system management password.

Set, change, and remove a password

Before you start, print these instructions.

1. Restart the computer. When the logo screen is displayed, press F1 or Fn+F1.
2. Select **Security**.
3. Depending on the password type, select **Set Supervisor Password**, **Set Power-On Password**, **Set System Management Password**, or **Hard Disk Password** and press Enter.
4. Follow the on-screen instructions to set, change, or remove a password.
5. Press F10 or Fn+F10 to save the changes and exit.

You should record your passwords and store them in a safe place. If you forget the passwords, contact a Lenovo-authorized service provider.

Note: If the hard disk password is forgotten, Lenovo cannot remove the password or recover data from the storage drive.

Chapter 4. UEFI BIOS

UEFI BIOS is the first program that the computer runs. When the computer turns on, the UEFI BIOS performs a self test to make sure that various devices in the computer are functioning properly.

Enter the UEFI BIOS menu

Turn on or restart the computer. When the logo screen is displayed, press F1 or Fn+F1 to enter the UEFI BIOS menu.

Note: If you have set UEFI BIOS passwords, enter the correct passwords when prompted. You also can select **No** or press Esc to skip the password prompt and enter the UEFI BIOS menu. However, you cannot change the system configurations that are protected by passwords.

Navigate the UEFI BIOS menu

Follow the on-screen instructions to navigate in the UEFI BIOS menu.

The table below introduces the available settings of the UEFI BIOS menu. You can follow the on-screen instruction to navigate in the UEFI BIOS menu.

Note: The UEFI BIOS menu might vary depending on system configurations.

Menu	Introduction
Main	This category provides the general product-related and firmware information including system summary, machine type, product serial number, UUID number, etc.
Devices	This category introduces how to configure various devices such as USB ports and audio controllers.
Advanced	This category provides advanced information about the computer such as the CPU features.
Power	This category introduces power and thermal management solutions.
Security	This category introduces various passwords, locks, and software to protect your computer.
Startup	This category introduces how to set the boot priority order.
Exit	This category introduces how to exit as you prefer.

You can go to Lenovo BIOS Simulator Center <https://download.lenovo.com/bsco/index.html> to explore the detailed settings by your product name.

Note: The Lenovo BIOS Simulator Center makes periodic updates of the settings. The UEFI BIOS simulator interface and description of settings might be different from that on your actual user interface.

Update the UEFI BIOS

When you install a new program, device driver, or hardware component, you might need to update the UEFI BIOS.

Download and install the latest UEFI BIOS update package by one of the following methods:

Using the built-in software update service

Ubuntu software update will check the LVFS site for any firmware updates and notify you when updates are available.

From the Lenovo Support Web site

Follow the instructions to update the UEFI BIOS from the Lenovo Support Web site.

- Step 1. Go to <https://pcsupport.lenovo.com> and select the entry for your computer.
- Step 2. Click **Drivers & Software → Manual Update → BIOS/UEFI**.
- Step 3. Follow the on-screen instructions to download and install the latest UEFI BIOS update package.

Chapter 5. CRU replacement

Before CRU replacement

Before replacing the hardware of your computer, read this section first. You will get to know what CRU is, the CRU list, system board connectors, and prerequisites for CRU replacement.

What is CRU

Customer Replaceable Units (CRUs) are parts that can be replaced by customers. Lenovo computers contain the following types of CRUs:

- **Self-service CRUs:** Refer to parts that can be replaced easily by customers themselves or by trained service technicians at an additional cost.
- **Optional-service CRUs:** Refer to parts that can be replaced by customers with a greater skill level. Trained service technicians can also provide service to replace the parts under the type of warranty designated for the customer's machine.

If you intend on installing the CRU, Lenovo will ship the CRU to you. CRU information and replacement instructions are shipped with your product and are available from Lenovo at any time upon request. You might be required to return the defective part that is replaced by the CRU. When return is required: (1) return instructions, a prepaid shipping label, and a container will be included with the replacement CRU; and (2) you might be charged for the replacement CRU if Lenovo does not receive the defective CRU within thirty (30) days of your receipt of the replacement CRU. For full details, see the Lenovo Limited Warranty documentation at:

https://www.lenovo.com/warranty/llw_02

CRU list

The following is the CRU list of your computer.

Self-service CRUs

- ac power adapter
- Chassis
- Dust filter*
- Keyboard*
- Mouse*
- PCI-Express card bracket
- Power cord

Optional-service CRUs

- LED cable
- LED cable holder
- Memory
- M.2 solid-state drive*
- M.2 solid-state drive thermal kit with thermal pad*
- COM cable kit
- PCI-Express card*

- PCI-Express card converter*
- Graphics card*
- Fiber modules of Ethernet PCI-Express adapter card*
- 3.5-inch HDD*
- HDD bracket kit*
- HDD cable*
- HDD Fan*

* for selected models

System board illustration

Note: The system board might look slightly different from the illustration.

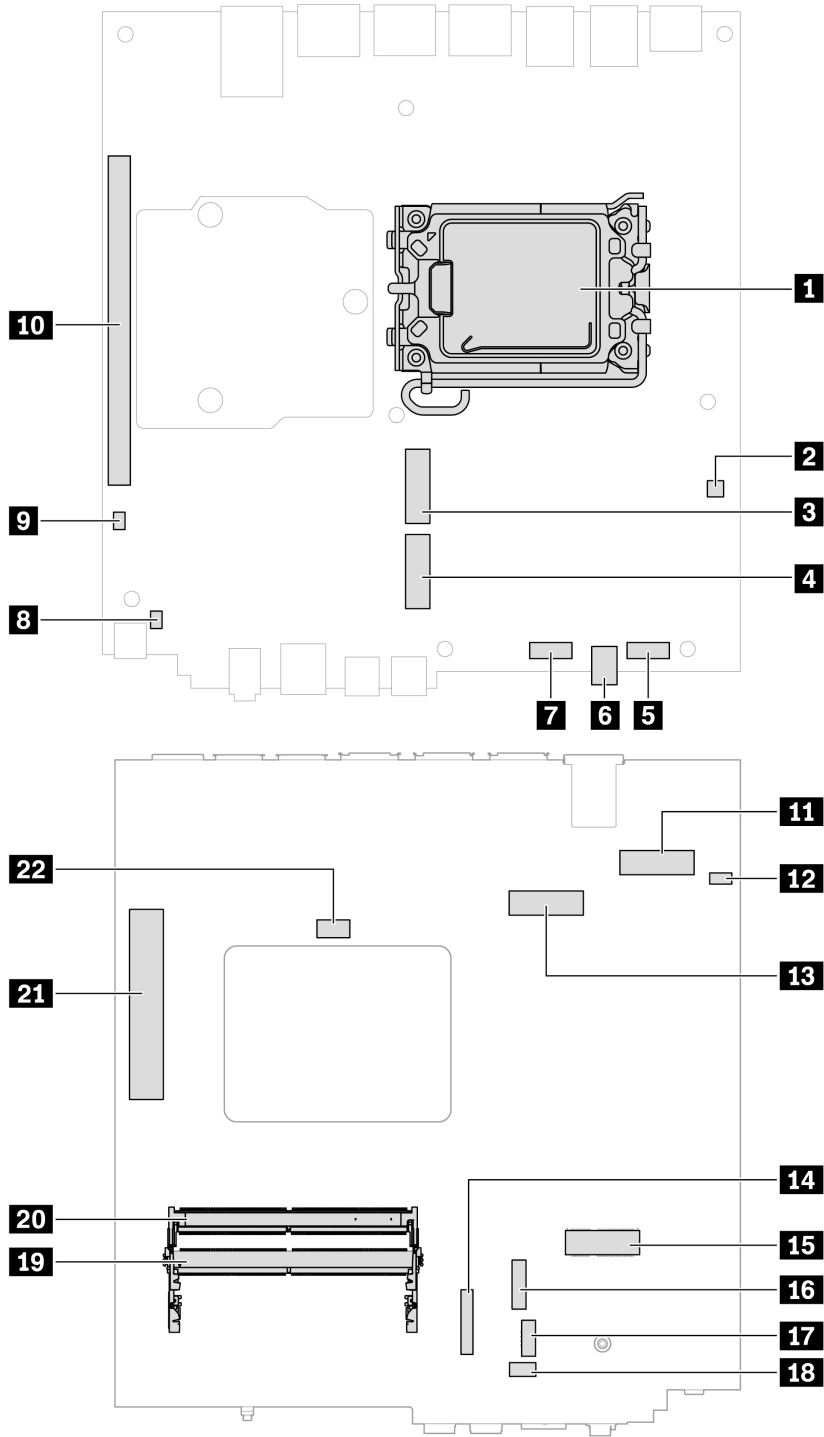

Figure 1. System board part locations

Item	Item
1 Microprocessor	2 Clear CMOS/Recovery jumper
3 Gen 4 M.2 solid-state drive slot 2	4 Gen 5 M.2 solid-state drive slot 1

Item	Item
5 System fan connector 1	6 Cover presence switch
7 System fan connector 2	8 Internal speaker connector
9 Power button connector	10 PCI-Express x16 card slot
11 Thunderbolt 4 board to board connector	12 Coin-cell battery connector
13 Gen 4 M.2 solid-state drive slot 3	14 BMC connector
15 M.2 Wi-Fi card slot	16 SATA connector
17 Auxiliary fan connector	18 ThinkStation LED connector
19 DIMM slot 1	20 DIMM slot 2
21 PCI-Express x4 slot (physical link width x8; negotiable link width x4)	22 COM port connector

Prerequisites for hardware replacement

General prerequisites

Read *Generic Safety and Compliance Notices*.

Prerequisites for opening computer chassis



During operation, some components become hot enough to burn the skin. Before you open the computer cover, do the following :

- Turn off the computer and remove all connected devices and cables.
- Disconnect the computer from ac power and all connected cables.
- Unlock any locking device that secures the chassis.
- Wait approximately 10 minutes until the computer is cool.

Prerequisites for storage drive replacement

Attention: The internal storage drive is sensitive. Inappropriate handling might cause damage and loss of data. When handling the internal storage drive, observe the following guidelines:

- Replace the internal storage drive only for repair. The internal storage drive is not designed for frequent changes or replacement.
- Before replacing the internal storage drive, make backup copy of all the data that you want to keep.
- Do not touch the contact edge of the internal storage drive. Otherwise, the internal storage drive might get damaged.
- Do not apply pressure to the internal storage drive.
- Do not make the internal storage drive subject to physical shocks or vibration. Put the internal storage drive on soft material, such as a cloth, to absorb physical shocks.

Power adapter and power cord

Before you start, ensure that you have read “Prerequisite for CRU replacement” on page 20.

For access, turn off the computer and remove all connected devices and cables.

Removal steps

1. Remove the power adapter.

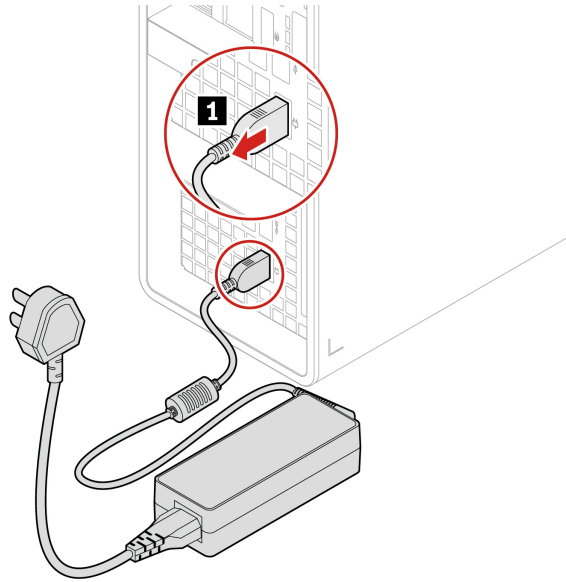

2. Remove the power cord.

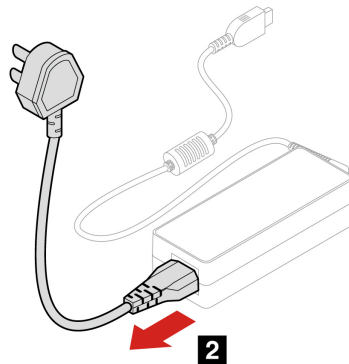

Dust filter

Before you start, ensure that you have read “Prerequisite for CRU replacement” on page 20.

Removal steps

Pull the dust filter to remove it from the chassis.

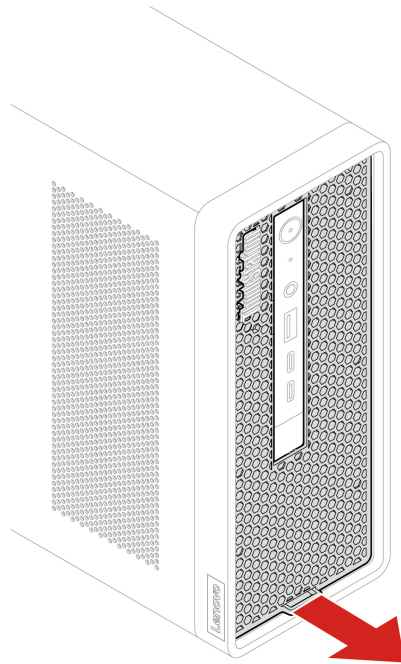

Chassis

Before you start, ensure that you have read “Prerequisite for CRU replacement” on page 20.

Removal steps

1. Push and open the chassis latch.

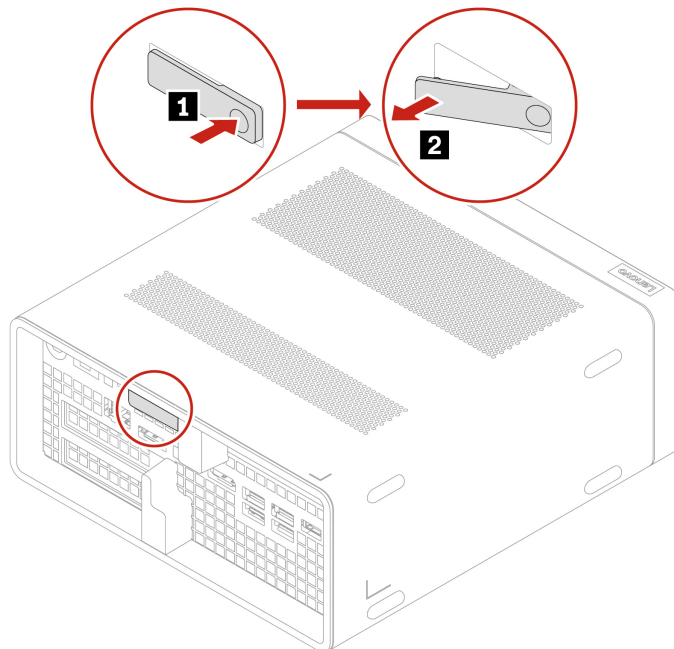

2. Pull the latch to remove the chassis.

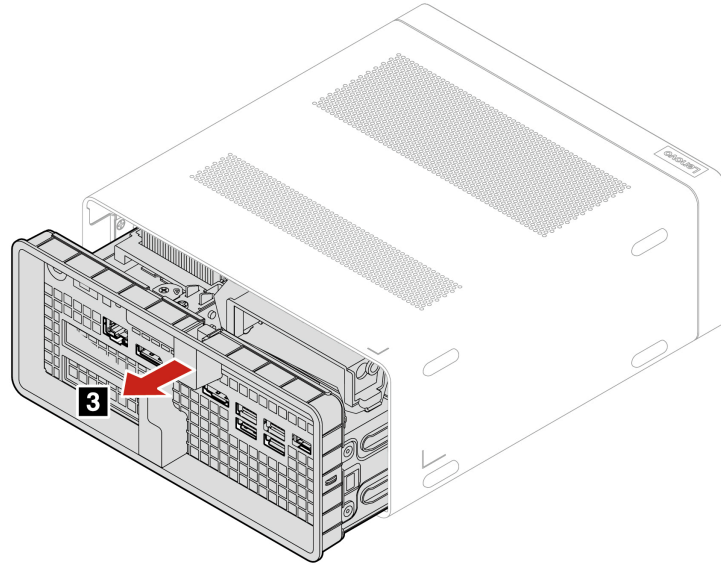

Installation steps

Install the chassis.

Note: Push the parts into place until you hear a clicking sound.

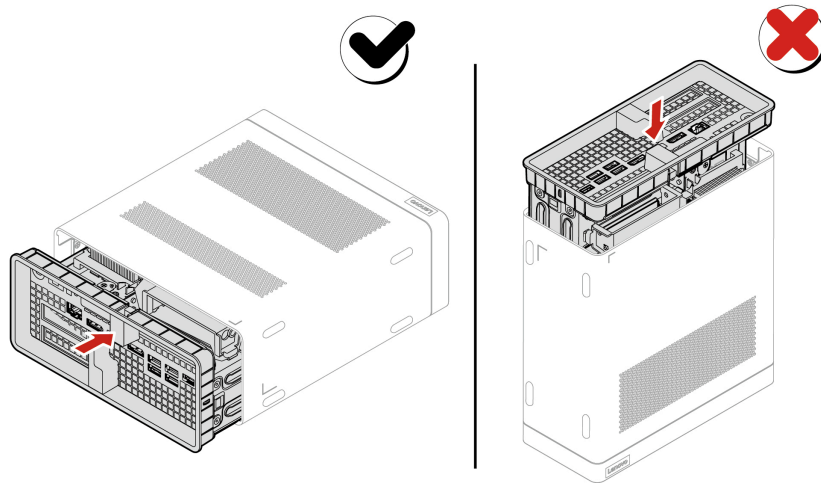

M.2 solid-state drive thermal kit

Before you start, ensure that you have read “Prerequisite for CRU replacement” on page 20.

For access, do the following:

1. Remove the power adapter and cord. See “Power adapter and power cord” on page 20.
2. Remove the chassis. See “Chassis” on page 22.
3. Remove the 3.5-inch hard disk drive bracket kit. See “3.5-inch hard disk drive bracket kit” on page 30
4. Disconnect the power cable from the thermal kit.

Removal steps

1. Remove the screw which secures the M.2 solid-state drive thermal kit to the chassis. Find screw specification in the following screw table.

Screw	Quantity	Torque
M3 x L5, hex screw	1	3 ± 0.5 in-lb

2. Remove the M.2 solid-state drive thermal kit.

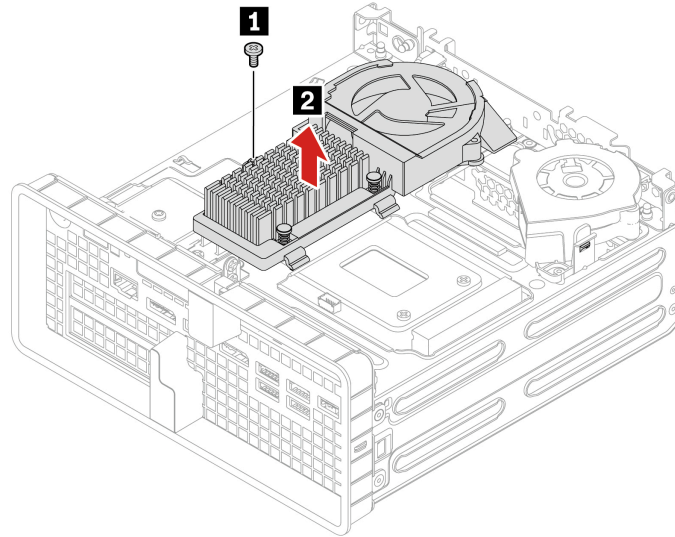

Installation steps

1. Align the two hooks on the M.2 solid-state drive thermal kit with the holes on the chassis.
2. Secure the M.2 solid-state drive thermal kit with a screw. Find screw specification in the following screw table.

Screw	Quantity	Torque
M3 x L5, hex screw	1	3 ± 0.5 in-lb

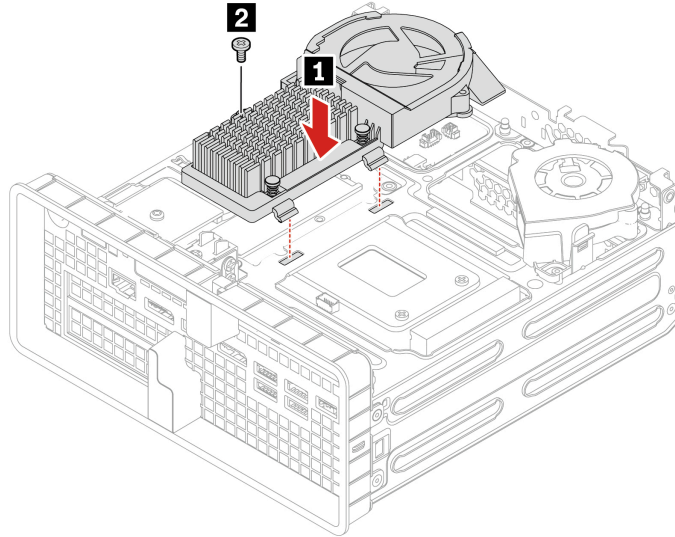

Attention: Use the screws provided by Lenovo to avoid any unpredictable damage to your computer.

M.2 solid-state drive

Before you start, ensure that you have read “Prerequisite for CRU replacement” on page 20.

For access, do the following:

1. Remove the power adapter and cord. See “Power adapter and power cord” on page 20.
2. Remove the chassis. See “Chassis” on page 22.
3. Remove the 3.5-inch hard disk drive bracket kit. See “3.5-inch hard disk drive bracket kit” on page 30.
4. Remove the M.2 solid-state drive thermal kit. See “M.2 solid-state drive thermal kit” on page 23.

Notes:

- Ensure that you follow the installation order for M.2 solid-state drives shown in the following illustration.
- Install Gen 5 M.2 solid-state drive only in slot 1.

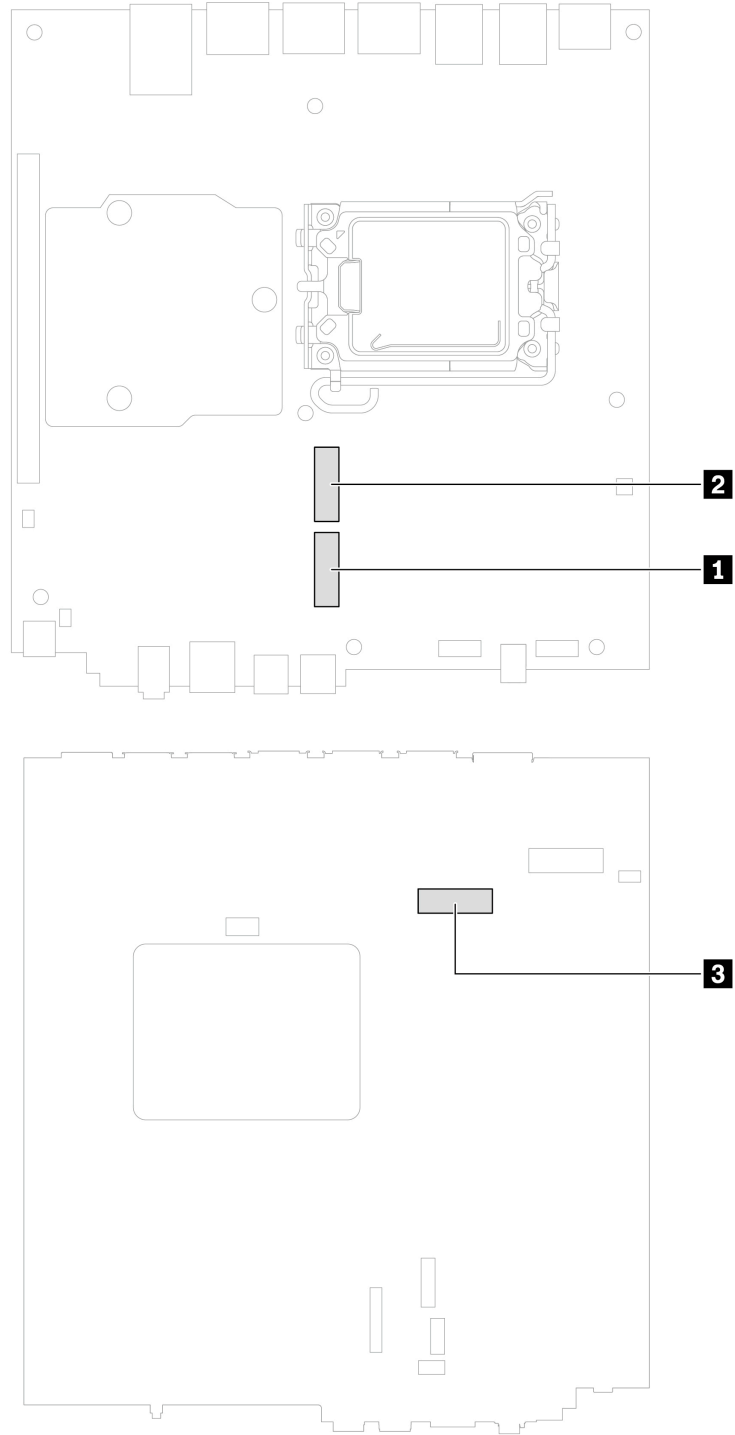

Removal steps for M.2 solid-state drive in slot 3

1. Remove the screw which secures the M.2 solid-state drive to the system board. Find screw specification in the following screw table.

Screw	Quantity	Torque
M2 x L3, flat head	1	1.5 ± 0.2 in-lb

- Remove the M.2 solid-state drive.

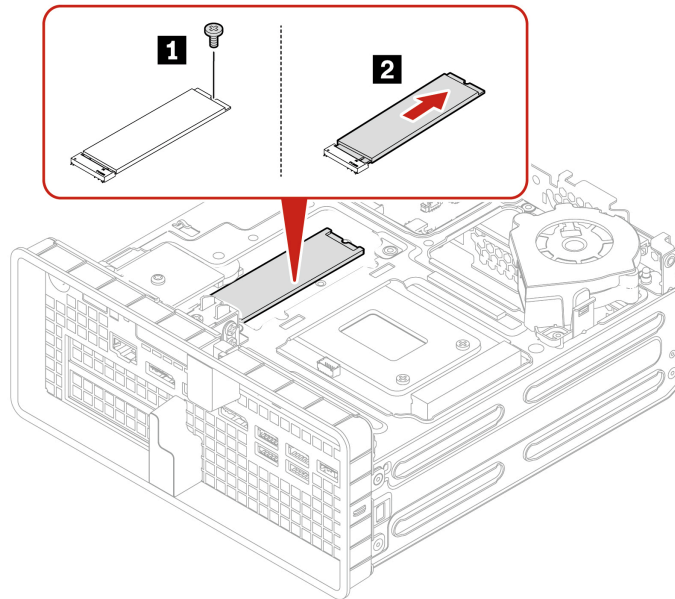

Removal steps for M.2 solid-state drive in slot 1 and slot 2

- Remove the system fan.
 - Remove the 65-watt system fan.
 - Remove the three screws which secure the 65-watt system fan. Find screw specification in the following screw table.

Screw	Quantity	Torque
M2.5 x L4.5, flat head	3	1.5 ± 0.2 in-lb

- Lift the system fan.

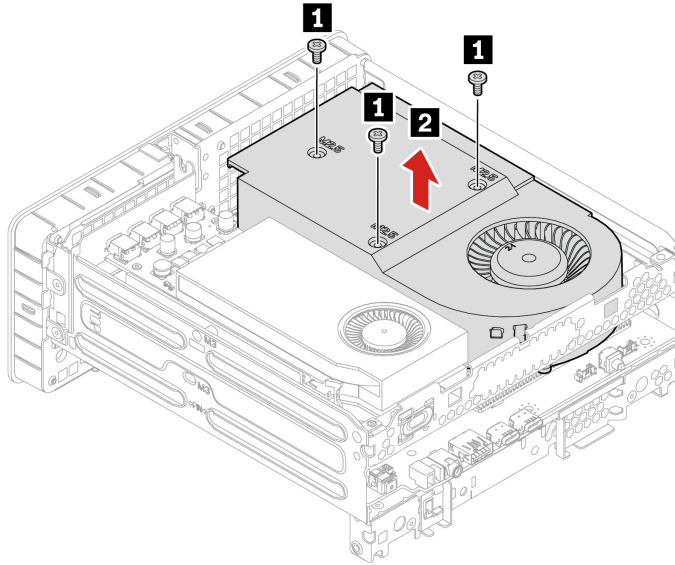

- Remove the 125-watt system fan.
 - a. Remove the seven screws which secure the 125-watt system fan. Find screw specification in the following screw table.

Screw	Quantity	Torque
M2.5 x L4.5, flat head	6	1.5 ± 0.2 in-lb
M3 x L5, countersunk	1	5.0 ± 0.5 in-lb

- b. Lift the system fan.

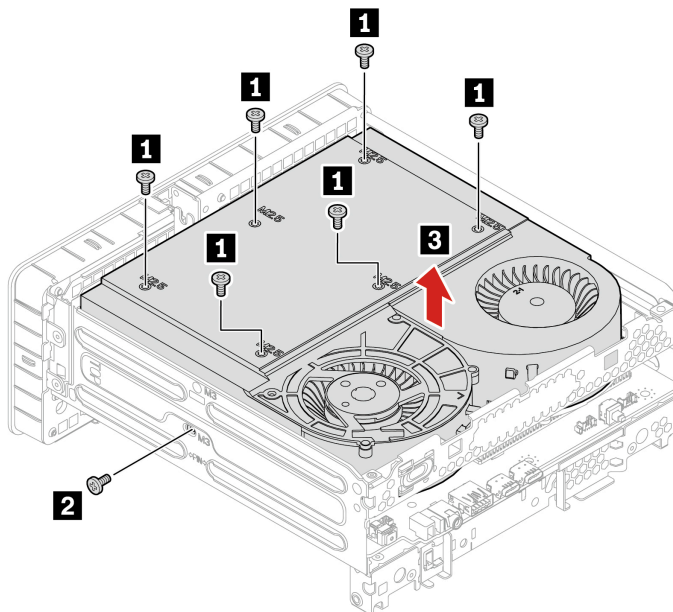

2. Remove the M.2 solid-state drive heatsink. Find screw specification in the following screw table.

Screw	Quantity	Torque
M2 x L3, flat head	1	1.5 ± 0.2 in-lb

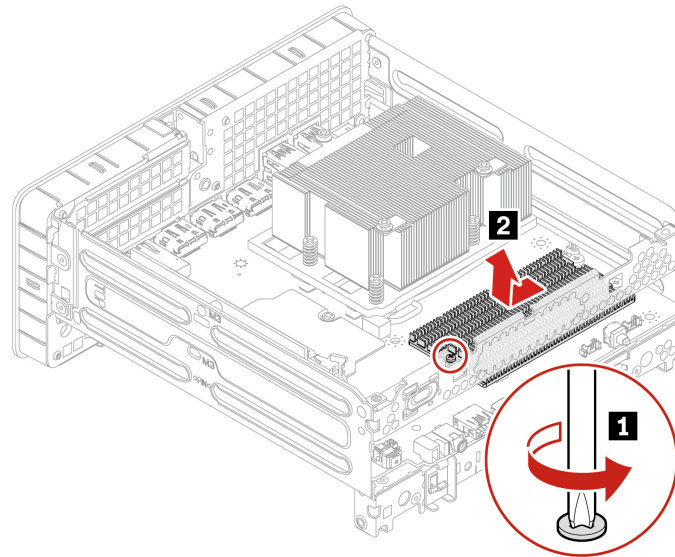

3. Remove the M.2 solid-state drive. Find screw specification in the following screw table.

Screw	Quantity	Torque
M2 x L3, flat head	1	1.5 ± 0.2 in-lb

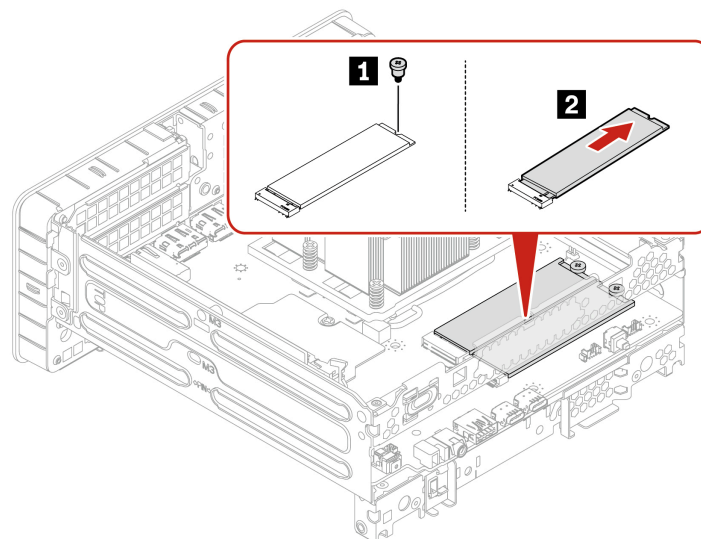

Hard disk drive fan

Before you start, ensure that you have read “Prerequisite for CRU replacement” on page 20.

For access, do the following:

1. Remove the power adapter and cord. See “Power adapter and power cord” on page 20.
2. Remove the chassis. See “Chassis” on page 22.
3. Disconnect the cable from the hard disk drive fan.

Removal steps

Press the tab to release the hard disk drive fan from the chassis.

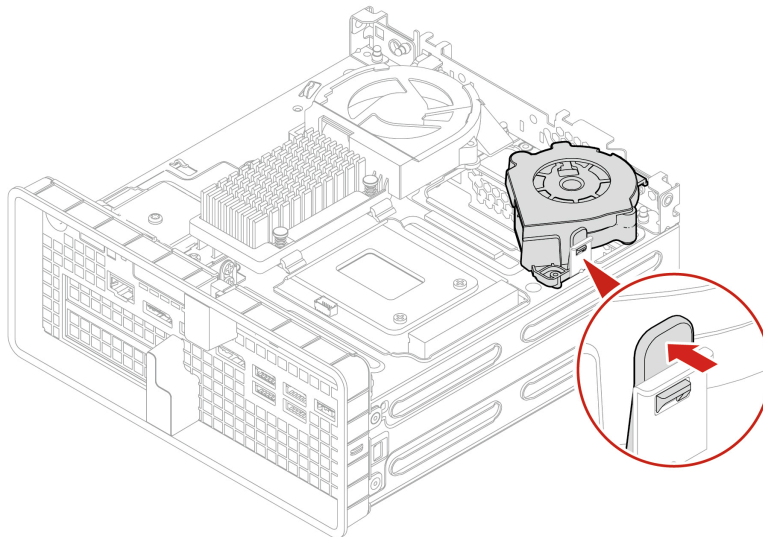

3.5-inch hard disk drive bracket kit

Before you start, ensure that you have read “Prerequisite for CRU replacement” on page 20.

For access, do the following:

1. Remove the power adapter and cord. See “Power adapter and power cord” on page 20.
2. Remove the chassis. See “Chassis” on page 22.
3. Disconnect the signal cable and the power cable from the storage drive.

Removal steps

1. Remove the four screws which secure the 3.5-inch hard disk drive bracket kit to the chassis. Find screw specification in the following screw table.

Screw	Quantity	Torque
M3 x L5, hex screw	4	5 ± 0.5 in-lb

2. Lift the 3.5-inch hard disk drive bracket kit.

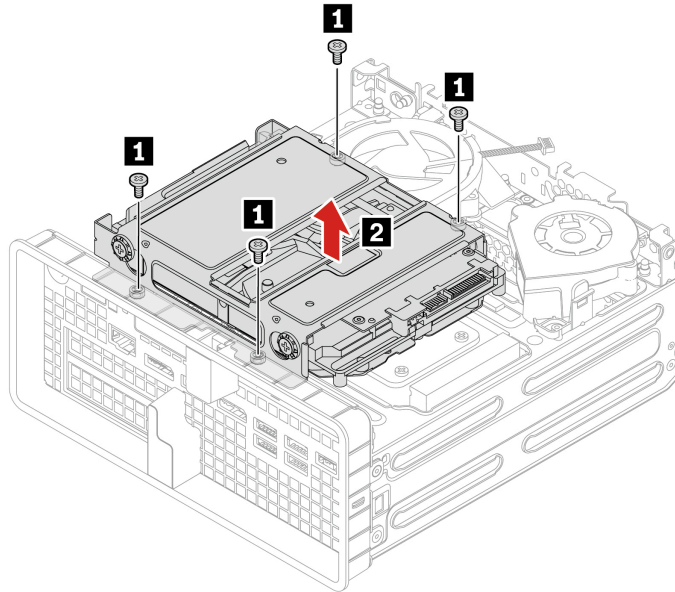

3.5-inch hard disk drive

Before you start, ensure that you have read “Prerequisite for CRU replacement” on page 20.

For access, do the following:

1. Remove the power adapter and cord. See “Power adapter and power cord” on page 20.
2. Remove the chassis. See “Chassis” on page 22.
3. Remove the 3.5-inch hard disk drive bracket kit. See “3.5-inch hard disk drive bracket kit” on page 30.
4. Disconnect the signal cable and the power cable from the storage drive.

Removal steps

1. Remove the four screws which secure the 3.5-inch hard disk drive to the bracket kit. Find screw specification in the following screw table.

Screw	Quantity	Torque
#6-32 x L11, flat head	4	5 ± 0.5 in-lb

2. Remove the 3.5-inch hard disk drive from the bracket kit.

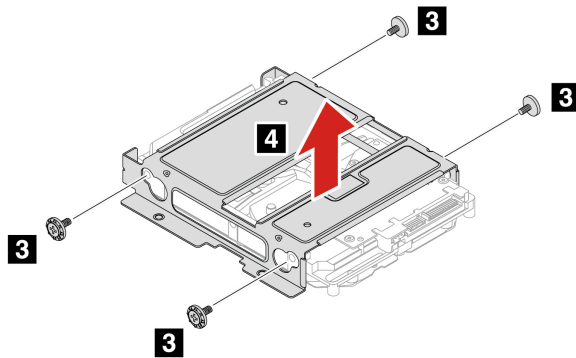

LED cable and holder

Before you start, ensure that you have read “Prerequisite for CRU replacement” on page 20.

For access, do the following:

1. Remove the power adapter and cord. See “Power adapter and power cord” on page 20.
2. Remove the chassis. See “Chassis” on page 22.

Removal steps for LED holder

Pinch the two tabs of the LED holder and pull to remove it from the chassis.

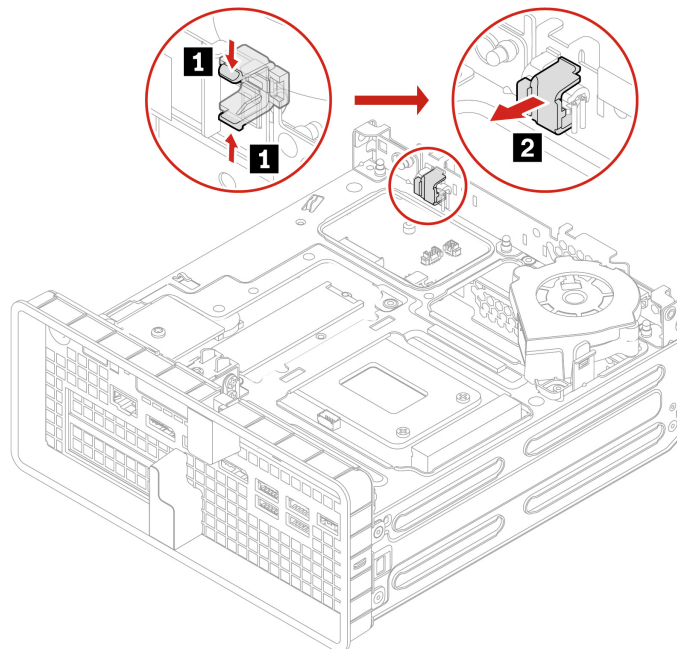

Removal steps for LED cable

Twirl to remove the LED cable.

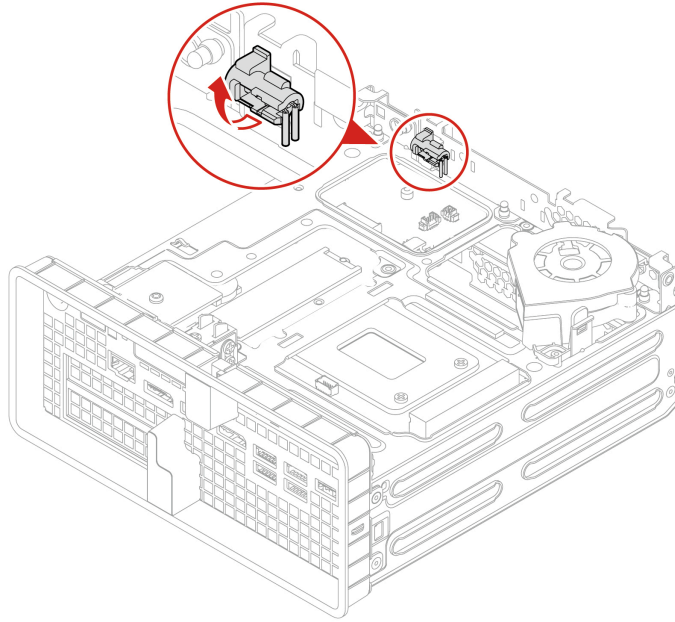

Memory module

Before you start, ensure that you have read “Prerequisite for CRU replacement” on page 20.

Notes:

- To remove or install the memory module, wait at least 20 seconds after disconnecting power cords from the system. It allows the system to be completely discharged of electricity.
- Ensure that you follow the installation order for memory modules shown in the following illustration.

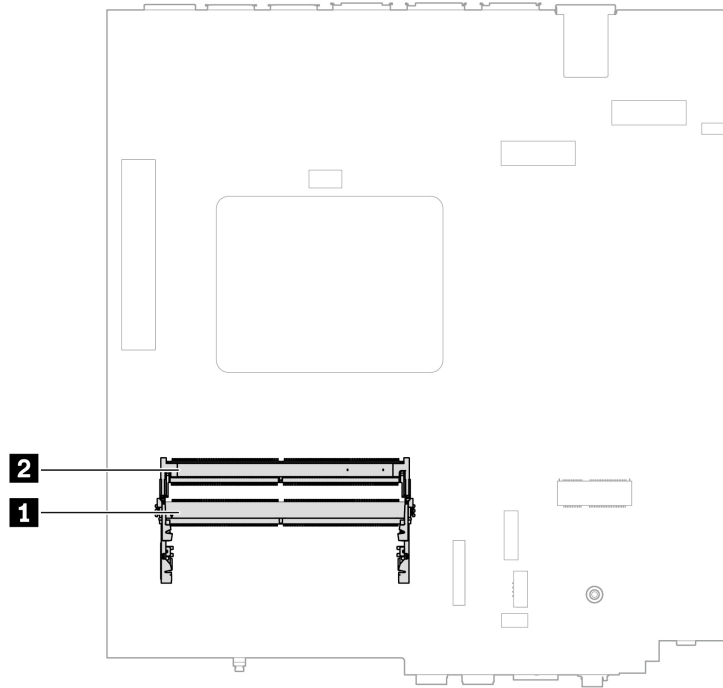

For access, do the following:

1. Remove the power adapter and cord. See “Power adapter and power cord” on page 20.
2. Remove the chassis. See “Chassis” on page 22.
3. Remove the hard disk drive fan. See “Hard disk drive fan” on page 30.

Removal steps

1. Open the two retaining tabs.
2. Lift the memory module out of the slot.

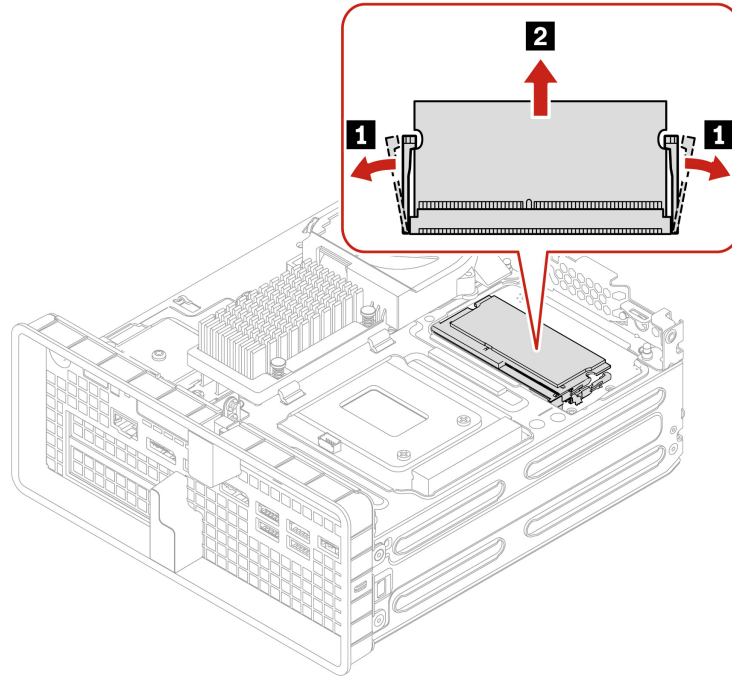

Installation steps

Align the memory module to the slot and push until the latches are fully engaged with a click.

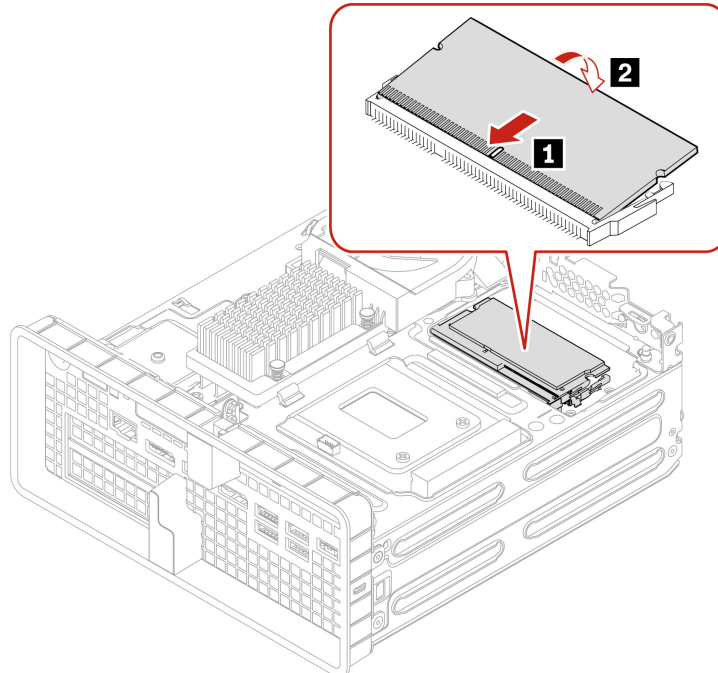

PCI-Express bracket

Before you start, ensure that you have read “Prerequisite for CRU replacement” on page 20.

For access, do the following:

1. Remove the power adapter and cord. See “Power adapter and power cord” on page 20.
2. Remove the chassis. See “Chassis” on page 22.

Removal steps

Open the latch and remove the PCI-Express bracket.

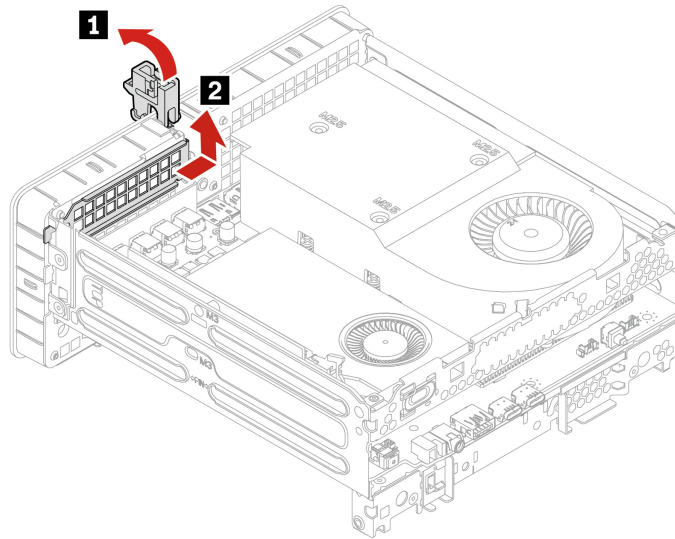

PCI-Express card (including graphics card)

Before you start, ensure that you have read “Prerequisite for CRU replacement” on page 20.

For access, do the following:

1. Remove the power adapter and cord. See “Power adapter and power cord” on page 20.
2. Remove the chassis. See “Chassis” on page 22.
3. Remove the PCI-Express bracket. See “PCI-Express bracket” on page 35.

Note: Before installing a new PCI-Express card, remove any PCI-Express connector cables that impede the installation.

PCI-Express card installation rule

- For graphics cards installation, the PCI-Express x16 slot is the primary slot, and the PCI-Express x4 slot is the secondary slot.
- For other PCI-Express cards installation, the PCI-Express x4 slot is the primary slot, and the PCI-Express x16 slot is the secondary slot.
- Before installing a new PCI-Express card, ensure your power supply has adequate capacity and verify the microprocessor’s power requirements to maintain system stability. You can refer to the table below for detailed power requirement.

Power supply	Microprocessor	PCI-Express card
230 watt	35 watt	You can install a graphics card and a PCI-Express card with power consumption below 30 watt. Note: You are recommended to install one graphics card only.
230 watt	65 watt	You can install a graphics card with power consumption below 50 watt only.
330 watt	35 watt / 65 watt	330-watt power supply can support higher-consumption PCI-Express cards and graphics cards.

- To install a dual-slot graphics card, such as RTX 2000E Ada or RTX 4000 SFF Ada, a single-slot PCI-Express card converter is required.

Removal steps

1. Open the latch and pull to remove the PCI-Express card.

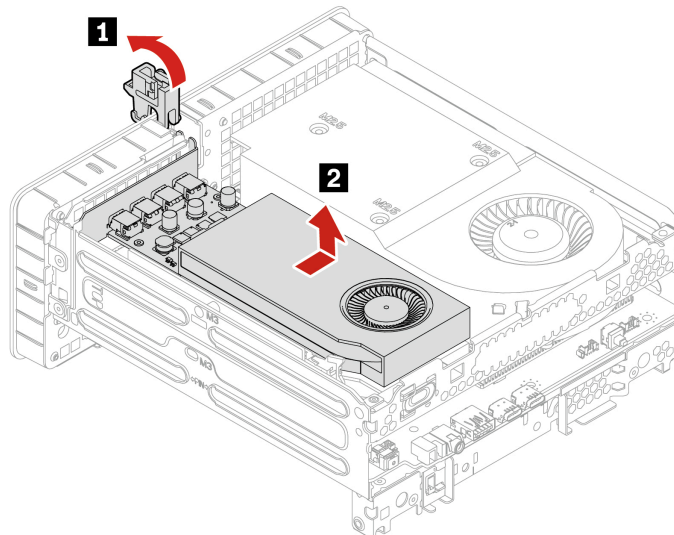

2. For some Ethernet PCI-Express adapter cards, the following fiber modules can be removed.

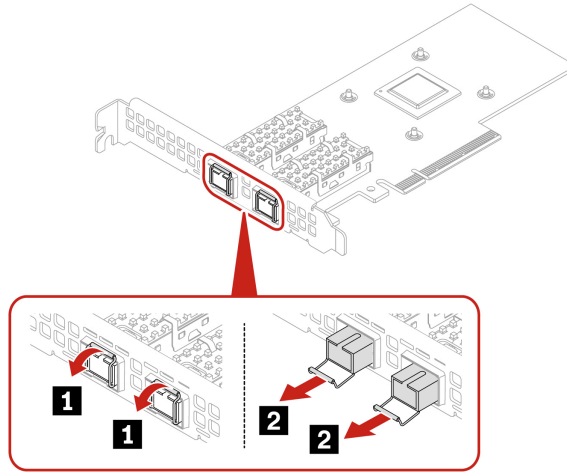

PCI-Express card converter

Before you start, ensure that you have read “Prerequisite for CRU replacement” on page 20.

For access, do the following:

1. Remove the power adapter and cord. See “Power adapter and power cord” on page 20.
2. Remove the chassis. See “Chassis” on page 22.
3. Remove the PCIe bracket. See “PCI-Express bracket” on page 35.
4. Remove the PCIe card. See “PCI-Express card (including graphics card)” on page 36

Removal steps for dual-slot PCI-Express card converter

1. Remove the screw that secure the converter to the chassis. Find screw specification in the following screw table.

Screw	Quantity	Torque
M3 x L5, countersunk	1	3 ± 0.5 in-lb

2. Pull the PCI-Express card converter out of the PCI-Express slot.

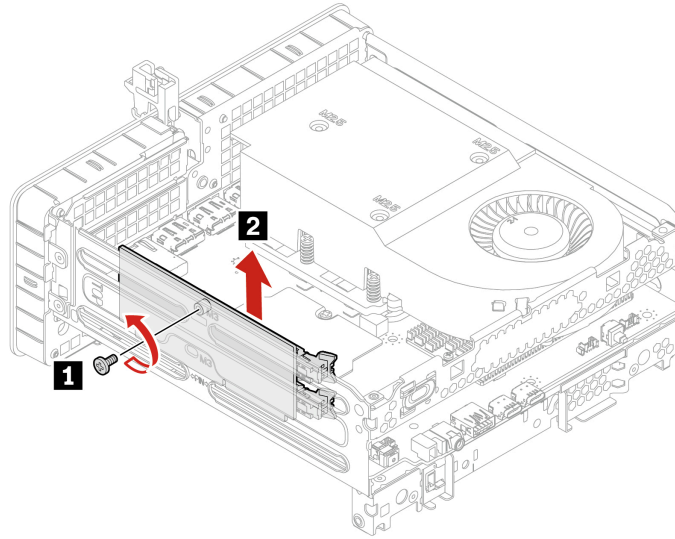

Notes: Ensure that you follow the installation order for dual-slot PCI-Express card converter:

- For graphics cards installation, slot 1 is the primary slot.
- For other PCI-Express cards installation, slot 2 is the primary slot and slot 1 is the secondary slot.

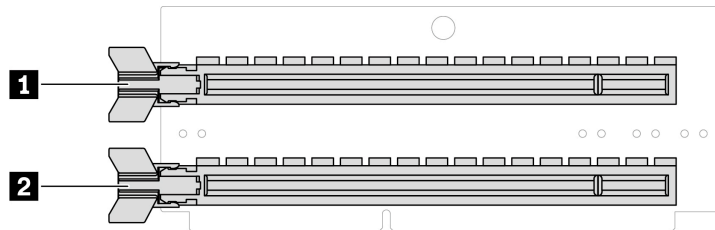

Removal steps for single-slot PCI-Express card converter

1. Remove the screw that secure the converter to the chassis. Find screw specification in the following screw table.

Screw	Quantity	Torque
M3 x L5, countersunk	1	3 ± 0.5 in-lb

2. Pull the PCI-Express card converter out of the PCI-Express slot.

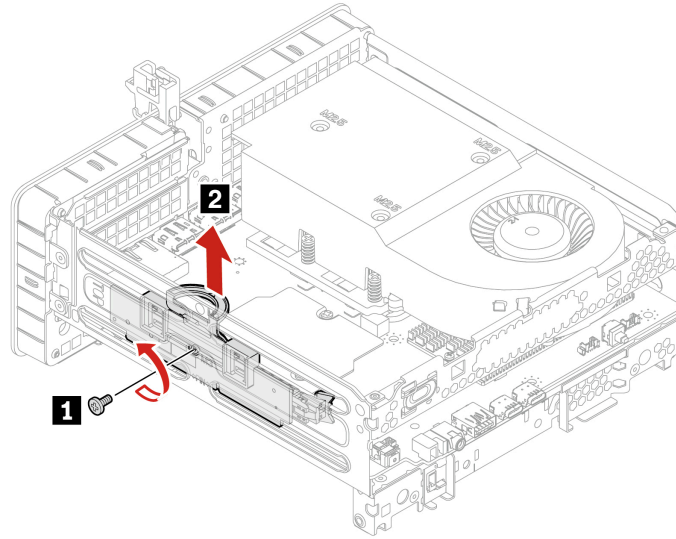

Chapter 6. Help and support

Find your serial number

This topic helps you find computer serial number.

You can find your serial number via:

- Open the Terminal and run `sudo dmidecode -t system | grep Serial`.
- Check the machine-type model and serial-number label of your computer (see illustration below).

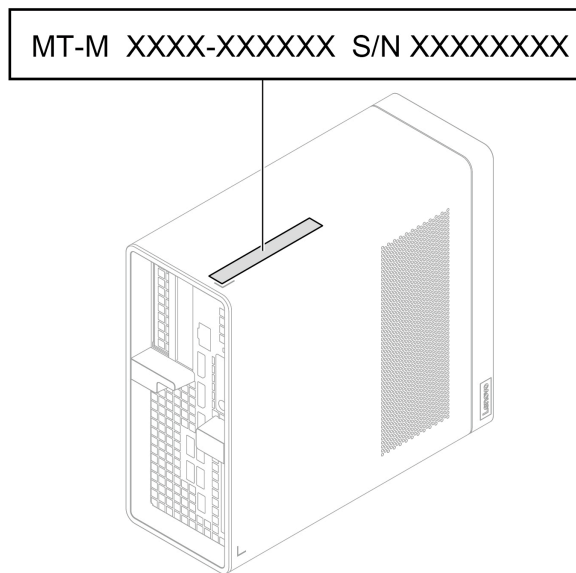

Lenovo diagnostic tools

For information about Lenovo diagnostic tools, go to:
<https://pcsupport.lenovo.com/lenovodiagnosicsolutions>

Call Lenovo

If you have tried to correct the problem yourself and still need help, you can call Lenovo Customer Support Center.

Before you contact Lenovo

Prepare the needed information before you contact Lenovo.

1. Record the problem symptoms and details:
 - What is the problem? Is it continuous or intermittent?
 - Any error message or error code?
 - What operating system are you using? Which version?
 - Which software applications were running at the time of the problem?
 - Can the problem be reproduced? If so, how?

- Record the system information:
 - Product name.
 - Machine type and “serial number” on page 41.

Lenovo Customer Support Center

During the warranty period, you can call Lenovo Customer Support Center for help.

Telephone numbers

For a list of the Lenovo Support phone numbers for your country or region, go to:
<https://pcsupport.lenovo.com/supportphonenumberlist>

Note: Phone numbers are subject to change without notice. If the number for your country or region is not provided, contact your Lenovo reseller or Lenovo marketing representative.

Services available during the warranty period

- Problem determination - Trained personnel are available to assist you with determining if you have a hardware problem and deciding what action is necessary to fix the problem.
- Lenovo hardware repair - If the problem is determined to be caused by Lenovo hardware under warranty, trained service personnel are available to provide the applicable level of service.
- Engineering change management - Occasionally, there might be changes that are required after a product has been sold. Lenovo or your reseller, if authorized by Lenovo, will make selected Engineering Changes (ECs) that apply to your hardware available.

Services not covered

- Replacement or use of parts not manufactured for or by Lenovo or nonwarranted parts
- Identification of software problem sources
- Configuration of UEFI BIOS as part of an installation or upgrade
- Changes, modifications, or upgrades to device drivers
- Installation and maintenance of network operating systems (NOS)
- Installation and maintenance of programs

For the terms and conditions of the Lenovo Limited Warranty that apply to your Lenovo hardware product, see *Safety and Warranty Guide* that comes with your computer.

Self-help resources

Use the following self-help resources to learn more about the computer and troubleshoot problems.

Resources	How to access?
Lenovo Support Web Site	https://pcsupport.lenovo.com
Tips	https://www.lenovo.com/tips
Lenovo Community	https://forums.lenovo.com
Accessibility information	https://www.lenovo.com/accessibility
Ubuntu help information	https://help.ubuntu.com/its/ubuntu-help/index.html

Purchase accessories or additional services

This topic provides instructions on how to purchase accessories or additional services.

Accessories

Lenovo has a number of hardware accessories and upgrades to help expand the functionalities of your computer. Accessories include memory modules, storage devices, network cards, power adapters, keyboards, mice, and so on.

To shop at Lenovo, go to <https://www.lenovo.com/accessories>.

Additional services

During and after the warranty period, you can purchase additional services from Lenovo at <https://pcsupport.lenovo.com/warrantyupgrade>.

Service availability and service names might vary by country or region.

Accessibility features

Lenovo is committed to making information technology accessible to everyone, including individuals with hearing, vision, mobility, cognitive, or speech disabilities. To get the most up-to-date and detailed accessibility features information for the product, go to https://support.lenovo.com/docs/product_accessibility_features.

Supplemental information about the Ubuntu operating system

In limited countries or regions, Lenovo offers customers an option to order computers with the preinstalled Ubuntu® operating system.

If the Ubuntu operating system is available on your computer, read the following information before you use the computer. Ignore any information related to Windows-based programs, utilities, and Lenovo preinstalled applications in this documentation.

Access the Lenovo Limited Warranty

This product is covered by the terms of the Lenovo Limited Warranty (LLW), version L505-0010-02 08/2011. You can view the LLW in a number of languages from the following Web site. Read the Lenovo Limited Warranty at:
https://www.lenovo.com/warranty/llw_02

The LLW also is preinstalled on the computer. To access the LLW, go to the following directory:

```
/opt/Lenovo
```

If you cannot view the LLW either from the Web site or from your computer, contact your local Lenovo office or reseller to obtain a printed version of the LLW.

Access the Ubuntu help system

The Ubuntu help system provides information about how to use the Ubuntu operating system. To access the help system from Home Screen, move your pointer to the Launch bar, and then click the **Help** icon. If you cannot find the **Help** icon from the Launch bar, click the **Search** icon on the bottom left, and type Help to search it.

To learn more about the Ubuntu operating system, go to:
<https://www.ubuntu.com>

Access IGEL distributions

To learn more about the IGEL operating system, go to <https://www.igel.com/support>.

Get support information

If you need help, service, technical assistance, or more information about the Ubuntu operating system or other applications, contact the provider of the Ubuntu operating system or the provider of the application. If you need the service and support for hardware components shipped with your computer, contact Lenovo. For more information about how to contact Lenovo, refer to the *User Guide* and *Safety and Warranty Guide*.

To access the latest *User Guide* and *Safety and Warranty Guide*, go to:

<https://pcsupport.lenovo.com>

Access open-source information

This device includes software made publicly available by Lenovo, including software licensed under the General Public License and/or the Lesser General Public License (the open source software).

You may obtain a copy of the corresponding source code for any such open source software licensed under the General Public License and/or the Lesser General Public License (or any other license requiring us to make a written offer to provide corresponding source code to you) from Lenovo for a period of three years without charge except for the cost of media, shipping, and handling, upon written request to Lenovo. This offer is valid to anyone in receipt of this device.

You may send your request in writing to the address below accompanied by a check or money order for \$15 to:

Lenovo Legal Department
Attn: Open Source Team / Source Code Requests
8001 Development Dr.
Morrisville, NC 27560

Please include the version of the OS and the version of the Linux Kernel pre-shipped on this Device as part of your request. Be sure to provide a return address.

The open source software is distributed in hope it will be useful, but WITHOUT ANY WARRANTY; without even the implied warranty of MERCHANTABILITY or FITNESS FOR A PARTICULAR PURPOSE. See for example the GNU General Public License and/or the Lesser General Public License for more information.

To view additional information regarding licenses, acknowledgments and required copyright notices for the open source software shipped on your Device, go to `/usr/share/doc/*/copyright`.

Appendix A. Important notice for Quebec consumers

In regard to section 79.18 of Quebec's Regulation respecting the application of the Consumer Protection Act, Lenovo in no way guarantees the availability of (a) replacement parts; (b) repair services; and (c) information necessary to maintain or repair the goods. For up-to-date information on the technical support and parts available for your purchase, please consult <https://support.lenovo.com/ca/en>.

En ce qui concerne l'article 79.18 du Règlement d'application de la Loi sur la protection du consommateur du Québec, Lenovo ne garantit en aucune façon la disponibilité des éléments suivants : (a) les pièces de rechange; (b) les services de réparation; et (c) les renseignements nécessaires à l'entretien à la réparation du bien. Pour obtenir des renseignements à jour sur le soutien technique et les pièces disponibles pour votre achat, veuillez consulter <https://support.lenovo.com/ca/fr>.

Appendix B. Notice for USB connector name update

The USB Implementers Forum published a revision of the guideline for USB connector names in September, 2022. Lenovo follows the revised guideline and updates USB connector names accordingly. You can refer to the table below for naming update details.

Current name	Previous name
USB-A connector (Hi-Speed USB)	USB-A 2.0 connector
USB-A connector (USB 5Gbps)	USB-A 3.2 Gen 1 connector
USB-A connector (USB 10Gbps)	USB-A 3.2 Gen 2 connector
USB-A connector (USB 5Gbps, Always On USB)	Always on USB-A 3.2 Gen 1 connector
USB-A connector (USB 10Gbps, Always On USB)	Always on USB-A 3.2 Gen 2 connector
USB-C connector (USB 5Gbps)	USB-C (3.2 Gen 1) connector
USB-C connector (USB 10Gbps)	USB-C (3.2 Gen 2) connector
USB-C connector (USB 20Gbps)	USB 3.2 Gen 2x2
USB-C connector (USB4 20Gbps)	USB 4 Gen 2x2
USB-C connector (USB4 40Gbps)	USB-C (USB 4) connector
USB-C connector (Thunderbolt 3)	USB-C (Thunderbolt 3) connector
USB-C connector (Thunderbolt 4)	USB-C (Thunderbolt 4) connector

Appendix C. Notices and trademarks

Notices

Lenovo may not offer the products, services, or features discussed in this document in all countries. Consult your local Lenovo representative for information on the products and services currently available in your area. Any reference to a Lenovo product, program, or service is not intended to state or imply that only that Lenovo product, program, or service may be used. Any functionally equivalent product, program, or service that does not infringe any Lenovo intellectual property right may be used instead. However, it is the user's responsibility to evaluate and verify the operation of any other product, program, or service.

Lenovo may have patents or pending patent programs covering subject matter described in this document. The furnishing of this document does not give you any license to these patents. You can send license inquiries, in writing, to:

*Lenovo (United States), Inc.
8001 Development Drive
Morrisville, NC 27560
U.S.A.
Attention: Lenovo Director of Licensing*

LENOVO PROVIDES THIS PUBLICATION "AS IS" WITHOUT WARRANTY OF ANY KIND, EITHER EXPRESS OR IMPLIED, INCLUDING, BUT NOT LIMITED TO, THE IMPLIED WARRANTIES OF NON-INFRINGEMENT, MERCHANTABILITY OR FITNESS FOR A PARTICULAR PURPOSE. Some jurisdictions do not allow disclaimer of express or implied warranties in certain transactions, therefore, this statement may not apply to you.

Changes are made periodically to the information herein; these changes will be incorporated in new editions of the publication. To provide better service, Lenovo reserves the right to improve and/or modify the products and software programs described in the manuals included with your computer, and the content of the manual, at any time without additional notice.

The software interface and function and hardware configuration described in the manuals included with your computer might not match exactly the actual configuration of the computer that you purchase. For the configuration of the product, refer to the related contract (if any) or product packing list, or consult the distributor for the product sales. Lenovo may use or distribute any of the information you supply in any way it believes appropriate without incurring any obligation to you.

The products described in this document are not intended for use in implantation or other life support applications where malfunction may result in injury or death to persons. The information contained in this document does not affect or change Lenovo product specifications or warranties. Nothing in this document shall operate as an express or implied license or indemnity under the intellectual property rights of Lenovo or third parties. All information contained in this document was obtained in specific environments and is presented as an illustration. The result obtained in other operating environments may vary.

Lenovo may use or distribute any of the information you supply in any way it believes appropriate without incurring any obligation to you.

Any references in this publication to non-Lenovo Web sites are provided for convenience only and do not in any manner serve as an endorsement of those Web sites. The materials at those Web sites are not part of the materials for this Lenovo product, and use of those Web sites is at your own risk.

Any performance data contained herein was determined in a controlled environment. Therefore, the result obtained in other operating environments may vary significantly. Some measurements may have been made on development-level systems and there is no guarantee that these measurements will be the same on generally available systems. Furthermore, some measurements may have been estimated through extrapolation. Actual results may vary. Users of this document should verify the applicable data for their specific environment.

This document is copyrighted by Lenovo and is not covered by any open source license, including any Linux® agreement(s) which may accompany software included with this product. Lenovo may update this document at any time without notice.

For the latest information or any questions or comments, contact or visit the Lenovo Web site:

<https://pcsupport.lenovo.com>

HEVC Standard

This product may support digital video coding under certain versions of HEVC (High Efficiency Video Coding) standard and, if so, may be covered by patents at <https://accessadvance.com/advance-patent-lists/>.



Trademarks

Lenovo, the Lenovo logo, ThinkStation and the ThinkStation logo are trademarks of Lenovo. Intel, Intel Optane, and Thunderbolt are trademarks of Intel Corporation or its subsidiaries in the U.S. and/or other countries. Microsoft and Windows are trademarks of the Microsoft group of companies. Mini DisplayPort (mDP) and DisplayPort are trademarks of the Video Electronics Standards Association. NVIDIA is a registered trademark of NVIDIA Corporation. Dolby, Dolby Voice, Dolby Audio and Dolby Atmos are trademarks of Dolby Laboratories Licensing Corporation. The terms HDMI and HDMI High-Definition Multimedia Interface are trademarks or registered trademarks of HDMI Licensing LLC in the United States and other countries. USB4® and USB-C® are registered trademarks of USB Implementers Forum. Wi-Fi and Miracast are registered trademarks of Wi-Fi Alliance. All other trademarks are the property of their respective owners.

Lenovo