

**PHILIPS**

HD1175



English 3  
Bahasa Indonesia 8  
Bahasa Melayu 13  
Español 18  
Français 23  
Português do Brasil 28  
Tiếng Việt 33  
ภาษาไทย 38  
简体中文 44  
繁體中文 49  
한국어 54  
العربية 59  
فارسی 64

# Introduction

Congratulations on your purchase and welcome to Philips! To fully benefit from the support that Philips offers, register your product at [www.philips.com/welcome](http://www.philips.com/welcome). Read this user manual, the important information leaflet, and the quick start guide carefully before you use the appliance. Save them for future reference.

## Product overview

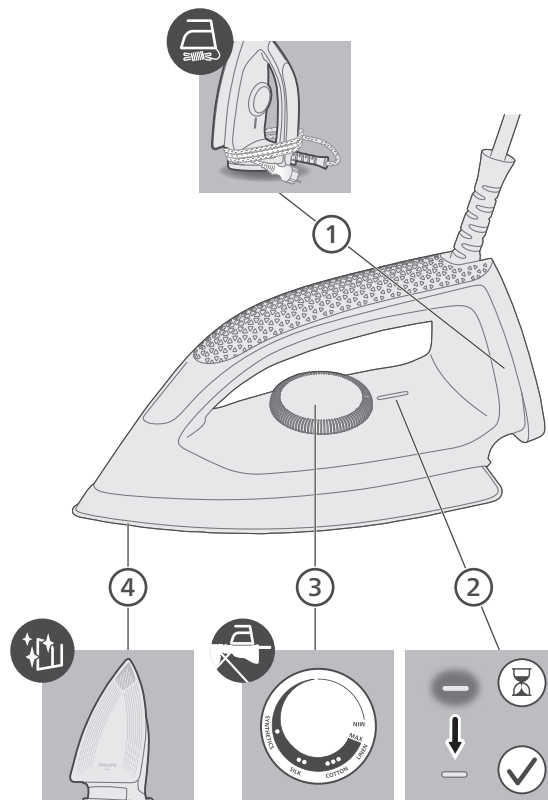

- 1 Cord storage
- 2 Indicator light
- 3 Temperature dial
- 4 Soleplate

# Hot iron warning



Caution: the soleplate and surrounding metal plate of the iron will be hot when in use.

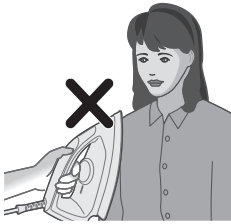

Do not position the iron towards yourself or others when in use.

# Using the appliance

## Setting the temperature



MAX  
LINEN



● ● ●  
COTTON



● ●  
SILK



●  
SYNTHETICS

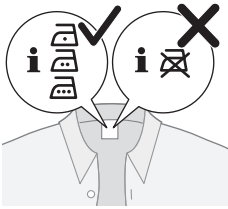

- 1 Check the garment label to ensure that the fabric is ironable.

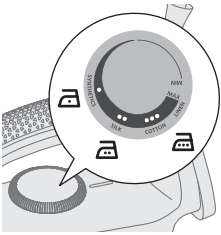

- 2 Check the table above for the correct temperature setting for the fabric. Turn the temperature dial to the correct setting - the indicator light marks the setting position.

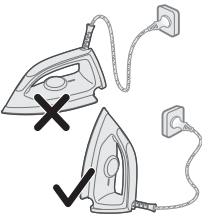

- 3 Plug into an earthed wall socket and allow the iron to rest on its heel. If using an extension plug, ensure that the power rating of the extension plug is suitable for the iron.

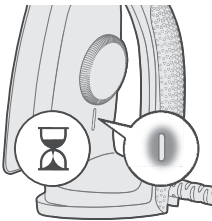

- 4 Wait for the iron to heat up. The indicator light will switch on when the iron is heating up.

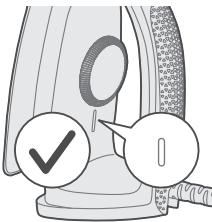

- 5 When the indicator light switches off, the iron is ready to use.

# Cleaning and maintenance

1 Ensure the iron is not plugged in.

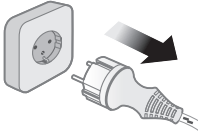

2 Ensure the iron has cooled down.

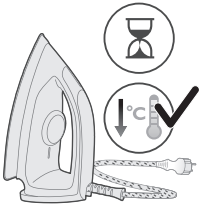

3 Wipe the soleplate with a damp cloth.

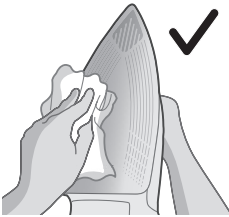

Note: To keep the soleplate smooth, avoid hard contact with metal objects. Never use a scouring pad, vinegar or other chemicals to clean the soleplate.



4 Do not wash/clean the iron under running water as it may damage the electrical components within.



# Storage

1 Unplug the iron.

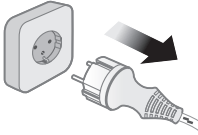

2 Let the iron cool down.

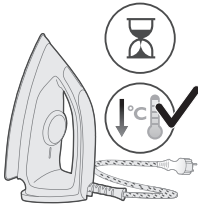

3 Coil the power cord neatly before storing it.

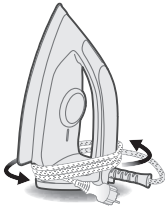

## Pendahuluan

Terima kasih telah membeli produk Philips! Untuk mendapatkan manfaat dukungan Philips secara penuh, daftarkan produk Anda di [www.philips.com/welcome](http://www.philips.com/welcome). Baca petunjuk pengguna ini, sebaran informasi penting, dan panduan mulai singkat dengan saksama sebelum Anda menggunakan alat ini. Simpanlah sebagai referensi jika dibutuhkan kelak.

## Ringkasan produk

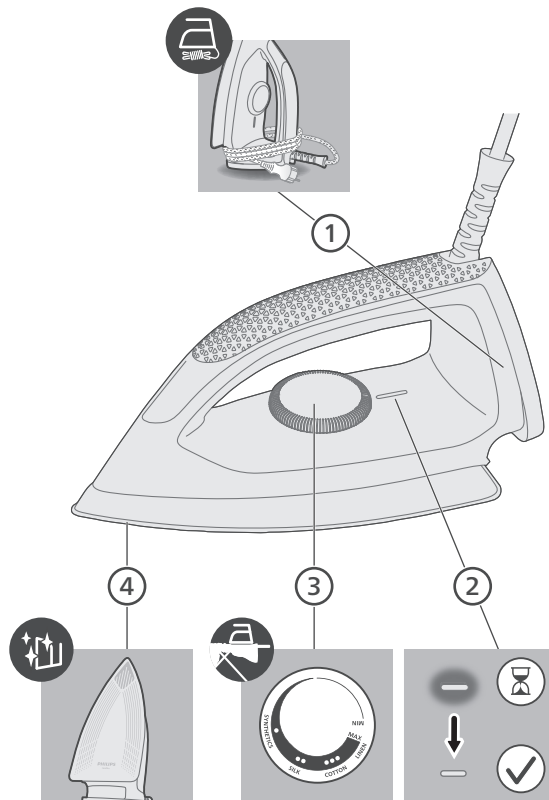

- 1 Penyimpanan kabel
- 2 Lampu indikator
- 3 Kenop suhu
- 4 Tapak setrika

## Peringatan setrika panas



Perhatian: tapak setrika dan pelat logam di sekeliling setrika akan panas saat alat digunakan.

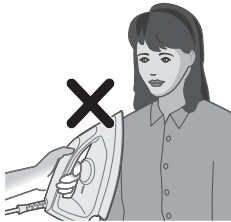

Jangan arahkan setrika menghadap Anda atau orang lain saat alat digunakan.

## Menggunakan alat

### Mengatur suhu



	MAKS LINEN
	● ● ● ● KATUN
	● ● SUTRA
	● SINTETIS

## 10 Bahasa Indonesia

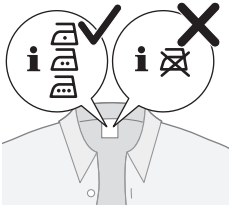

- 1 Lihat label pada pakaian untuk mengetahui bahannya aman disetrika atau tidak.

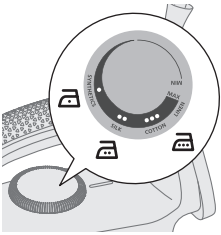

- 2 Lihat tabel di atas untuk mengetahui pengaturan suhu yang tepat untuk kain. Putar kenop suhu ke pengaturan yang tepat - lampu indikator menandakan posisi pengaturan.

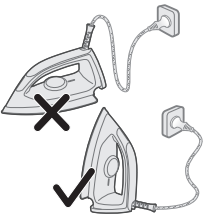

- 3 Colokkan steker ke stopkontak berarde dan berdirikan setrika. Jika menggunakan stopkontak ekstensi, pastikan kapasitas dayanya sesuai untuk setrika.

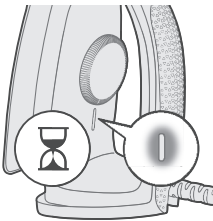

- 4 Tunggu hingga setrika memanas. Lampu indikator akan menyala ketika setrika sedang dipanaskan.

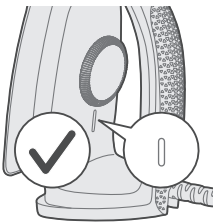

- 5 Setelah lampu indikator padam, setrika siap digunakan.

## Pembersihan dan pemeliharaan

- 1 Pastikan steker setrika tidak dicolokkan ke stopkontak.

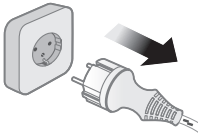

- 2 Pastikan setrika sudah dingin.

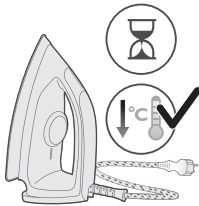

- 3 Seka tapak setrika dengan kain lembap.

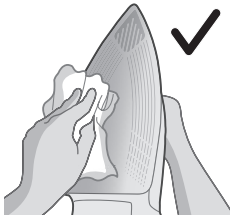

Catatan: Agar tapak setrika tetap licin, hindari kontak dengan benda logam. Jangan sekali-kali menggunakan sabut gosok, cuka, atau bahan kimia lain untuk membersihkan tapak setrika.



- 4 Jangan mencuci atau membersihkan setrika di bawah air mengalir karena dapat merusak komponen listrik yang ada di dalamnya.



## Penyimpanan

- 1 Cabut steker setrika dari stopkontak.

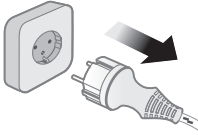

- 2 Biarkan setrika mendingin.

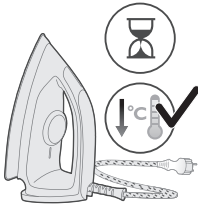

- 3 Gulung kabel listrik dengan rapi sebelum menyimpan alat.

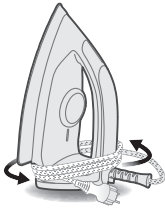

## Pengenalan

Tahniah atas pembelian anda dan selamat menggunakan Philips! Untuk mendapatkan manfaat sepenuhnya daripada sokongan yang ditawarkan oleh Philips, daftar produk anda di [www.philips.com/welcome](http://www.philips.com/welcome). Baca manual pengguna ini, risalah maklumat penting dan panduan permulaan ringkas dengan teliti sebelum anda menggunakan perkakas. Simpan untuk rujukan masa hadapan.

## Gambaran keseluruhan produk

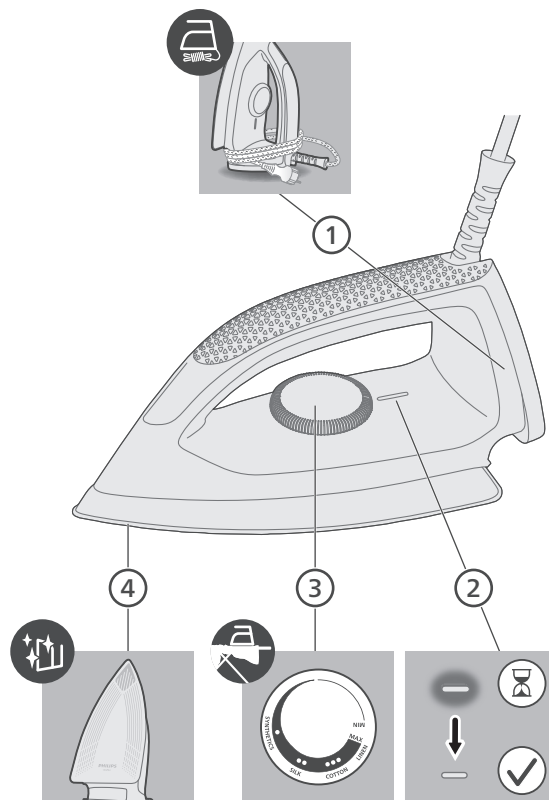

- 1 Penyimpanan kord
- 2 Lampu penanda
- 3 Tombol suhu
- 4 Tapak

## Amaran seterika panas



**Awas: tapak dan plat logam sekeliling seterika akan menjadi panas semasa penggunaan.**

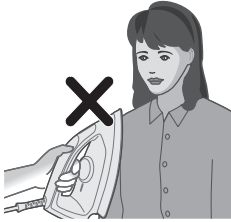

Jangan halakan seterika ke arah diri anda sendiri atau orang lain semasa penggunaan.

## Menggunakan perkakas

### Menetapkan suhu



MAX  
LINEN



● ● ●  
KAPAS



● ●  
SUTERA



●  
SINTETIK

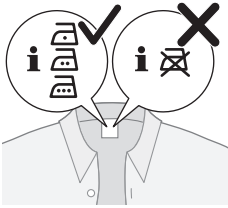

1 Periksa label pakaian untuk memastikan fabrik boleh diseterika.

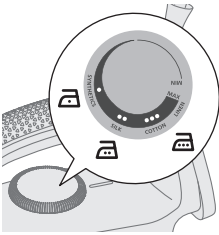

2 Semak jadual di atas untuk mengetahui tetapan suhu yang betul untuk fabrik. Putarkan tombol suhu kepada tetapan yang betul - lampu penanda menandakan kedudukan tetapan.

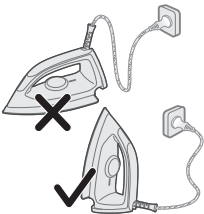

3 Pasangkan palam pada soket yang dibumikan dan dirikan seterika pada tumit seterika. Jika menggunakan palam sambungan, pastikan pengedaran kuasa palam sambungan sesuai untuk seterika.

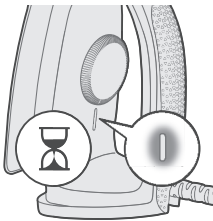

4 Tunggu seterika menjadi panas. Lampu penanda akan hidup apabila seterika sedang memanas.

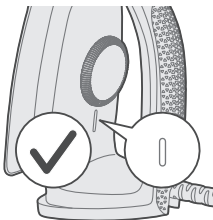

5 Apabila lampu penanda mati, seterika sedia digunakan.

# Pembersihan dan penyelenggaraan

1 Pastikan palam seterika tidak dipasang.

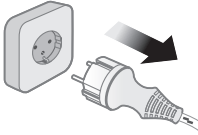

2 Pastikan seterika telah menyejuk.

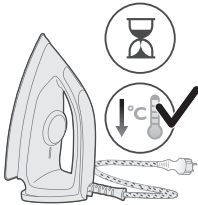

3 Lap tapak dengan kain lembap.

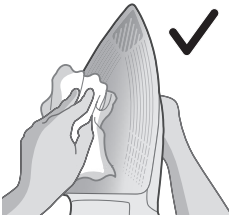

Nota: Untuk memastikan tapak kekal licin, elakkan daripada terlanggar dengan bahan logam. Jangan sekali-kali menggunakan pad penyental, cuka atau bahan kimia lain untuk membersihkan tapak plat.



4 Jangan cuci/bersihkan seterika di bawah air yang mengalir kerana ini boleh merosakkan komponen elektrik di dalam seterika.



# Penyimpanan

1 Cabut palam seterika.

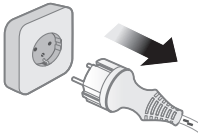

2 Biarkan seterika menyejuk.

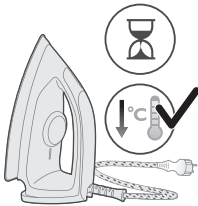

3 Gulungkan kord kuasa dengan kemas sebelum disimpan.

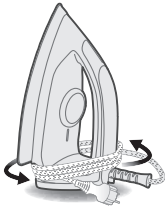

## Introducción

Le damos la enhorabuena por su adquisición y la bienvenida a Philips. Para poder beneficiarse por completo de la asistencia que ofrece Philips, registre el producto en [www.philips.com/welcome](http://www.philips.com/welcome). Lea con atención este manual de usuario, el folleto de información importante y la guía de inicio rápido antes de utilizar el aparato. Consérvelos por si necesitara consultarlos en el futuro.

## Descripción del producto

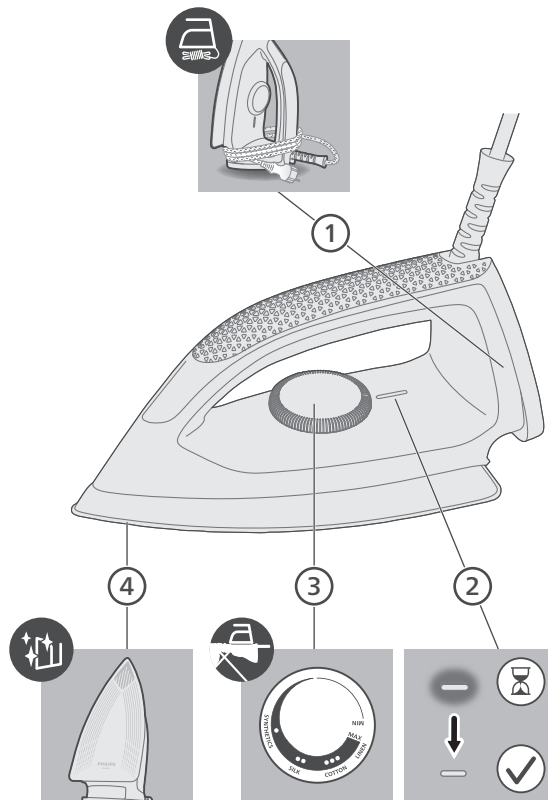

- 1 Recogecable
- 2 Piloto indicador
- 3 Botón de temperatura
- 4 Suela

## Advertencia sobre planchas calientes



**Precaución:** La suela de la plancha y la placa metálica que la rodea se calentarán durante el uso.

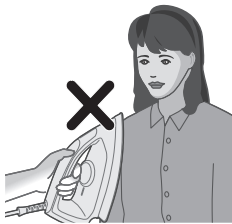

No apunte con la plancha hacia usted ni hacia otras personas cuando esté en uso.

## Uso del aparato

### Ajuste de la temperatura



MAX  
LINO



● ● ● ●  
ALGODÓN



● ●  
SEDA



●  
SINTÉTICO

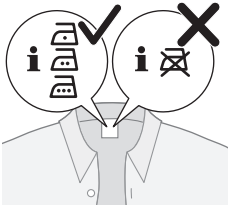

1 Consulte la etiqueta de la prenda para asegurarse de que el tejido es planchable.

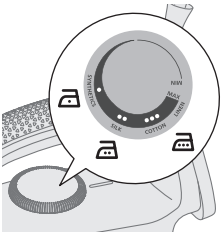

2 Consulte la tabla superior para conocer el ajuste de temperatura correcto para cada tipo de tejido. Coloque el dial de temperatura en el ajuste correcto; la luz indicadora marca la posición seleccionada.

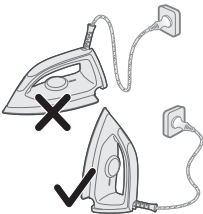

3 Enchufe la plancha a una toma con tierra y deje que descance sobre su base de apoyo. Si utiliza un enchufe de extensión, asegúrese de que la potencia nominal del enchufe de extensión es adecuada para la plancha.

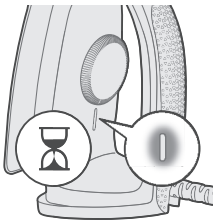

4 Espere a que la plancha se caliente. El piloto indicador se encenderá para indicar que la plancha se está calentando.

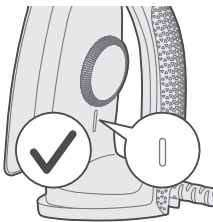

5 Cuando el piloto indicador se apague, la plancha estará lista para su uso.

# Limpeza y mantenimiento

- 1 Asegúrese de que la plancha no esté enchufada.

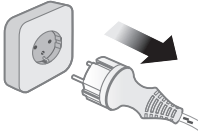

- 2 Asegúrese de que la plancha se haya enfriado.

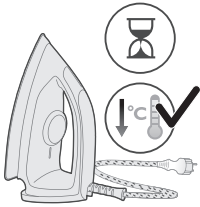

- 3 Limpie la suela con un paño húmedo.

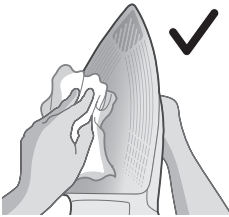

Nota: Con el fin de mantener la suela lisa, evite un contacto fuerte con objetos metálicos. No utilice nunca estropajos, vinagre ni productos químicos para limpiar la suela.

- 4 No lave ni limpie la plancha bajo el grifo, ya que podría dañar los componentes eléctricos de su interior.



# Almacenamiento

1 Desenchufe la plancha.

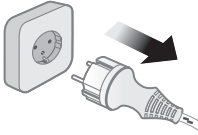

2 Deje enfriar la plancha.

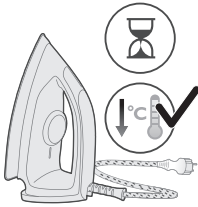

3 Enrolle el cable de alimentación de forma ordenada antes de guardarla.

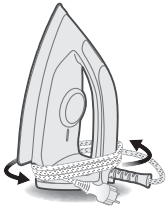

# Introduction

Félicitations pour votre achat et bienvenue chez Philips ! Pour profiter pleinement de l'assistance offerte par Philips, enregistrez votre produit à l'adresse suivante : [www.philips.com/welcome](http://www.philips.com/welcome). Lisez attentivement ce mode d'emploi, la brochure « Informations importantes » et le guide de démarrage rapide avant d'utiliser l'appareil. Conservez-les pour une consultation ultérieure.

## Présentation du produit

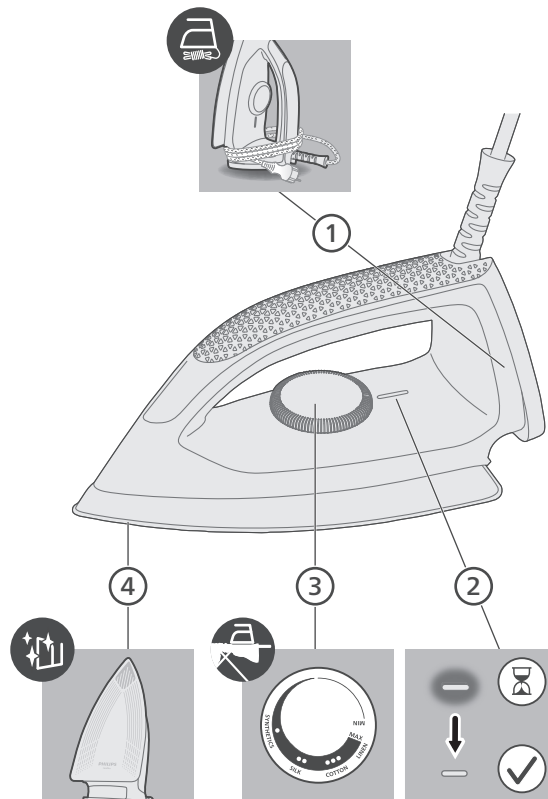

- 1 Range-cordon
- 2 Voyant
- 3 Thermostat
- 4 Semelle

## Fer chaud : avertissement



Attention : la semelle et la plaque métallique entourant le fer à repasser sont chaudes pendant l'utilisation.

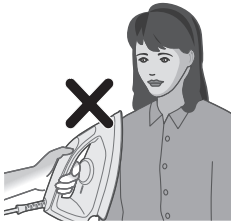

N'orientez pas le fer vers vous ou d'autres personnes lorsque vous l'utilisez.

## Utilisation de l'appareil

### Réglage de la température



MAX  
LIN



● ● ● ●  
COTON



● ●  
SOIE



●  
SYNTHÉTIQUE

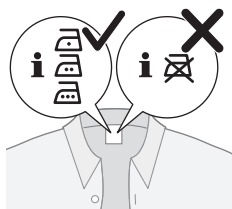

- 1 Consultez l'étiquette du vêtement pour vous assurer que le tissu est repassable.

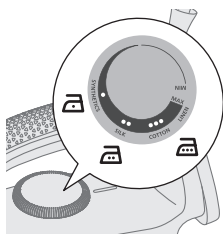

- 2 Consultez le tableau ci-dessus pour connaître le réglage de température adapté au tissu. Réglez le thermostat sur la position adéquate ; le voyant indique la position sélectionnée.

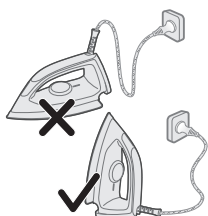

- 3 Branchez le fer à repasser sur une prise secteur et posez-le sur son talon. Si vous utilisez une rallonge, assurez-vous que sa puissance nominale est adaptée au fer à repasser.

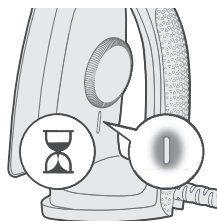

- 4 Attendez que le fer chauffe. Le voyant s'allume pendant la période de chauffe.

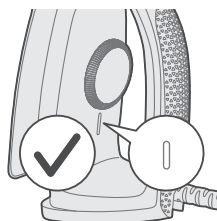

- 5 Lorsque le voyant s'éteint, le fer est prêt à l'emploi.

# Nettoyage et entretien

1 Assurez-vous que le fer n'est pas branché.

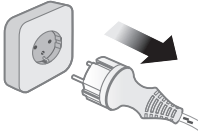

2 Assurez-vous que le fer a refroidi.

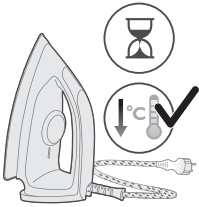

3 Essuyez la semelle avec un chiffon humide.

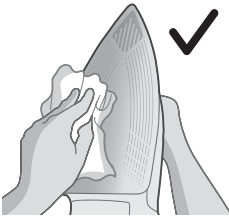

Remarque : évitez le contact de la semelle avec tout objet métallique afin de ne pas l'endommager. N'utilisez jamais de tampons à récurer, vinaigre ou autres produits chimiques pour nettoyer la semelle.



4 Ne nettoyez pas le fer sous le robinet. Cela pourrait endommager les composants électriques à l'intérieur.



# Rangement

1 Débranchez le fer à repasser.

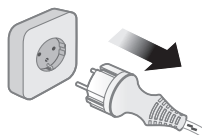

2 Laissez le fer refroidir.

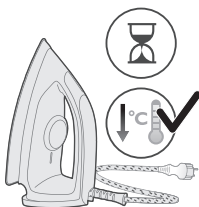

3 Avant de le ranger, enroulez soigneusement le cordon d'alimentation.

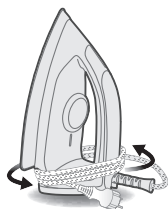

## Introdução

Parabéns pela sua aquisição e bem-vindo à Philips! Para aproveitar ao máximo o suporte oferecido pela Philips, registre seu produto em [www.philips.com/welcome](http://www.philips.com/welcome). Leia atentamente este manual do usuário, o folheto de informações importantes e o guia de início rápido antes de usar o aparelho. Guarde-os para consultas futuras.

## Visão geral do produto

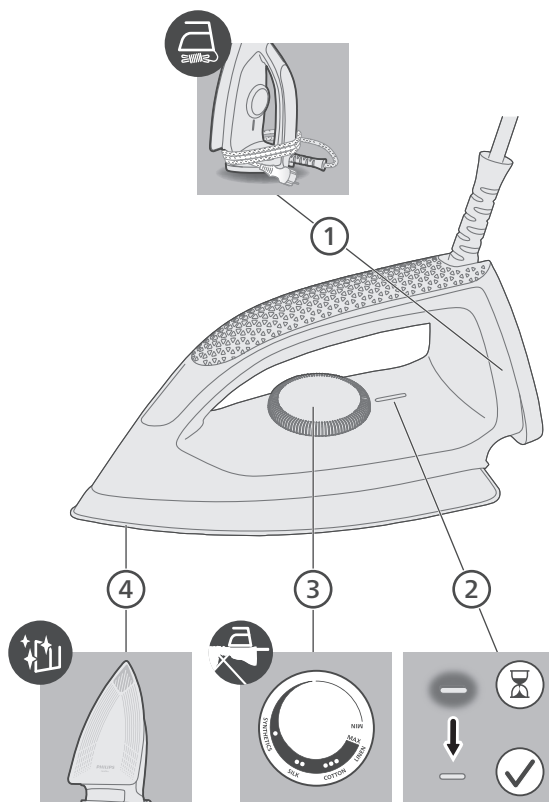

- 1 Armazenamento do cabo
- 2 Luz indicativa
- 3 Termostato
- 4 Base

## Aviso de ferro quente



**Cuidado:** a base e a estrutura de metal em volta do ferro estarão quentes durante o uso do aparelho.

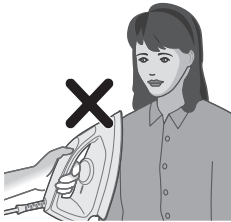

Não posicione o ferro na sua direção ou na direção de outras pessoas durante o uso.

## Utilização do aparelho

### Ajuste da temperatura



MÁX  
LINHO



● ● ● ●  
ALGODÃO



● ●  
SEDA



●  
SINTÉTICO

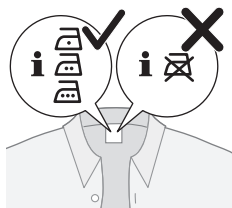

- 1 Leia a etiqueta da peça de roupa para verificar se o tecido pode ser passado a ferro.

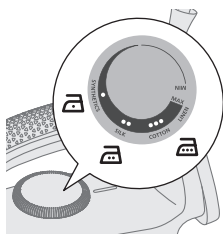

- 2 Consulte a tabela acima para saber o ajuste de temperatura correto para cada tecido. Gire o termostato para o ajuste correto. A luz indicadora marcará a posição de ajuste.

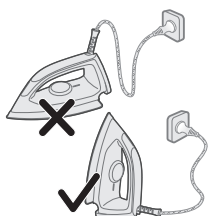

- 3 Conecte o aparelho a uma tomada de parede aterrada e deixe que o ferro descanse na posição vertical. Se estiver usando uma extensão, certifique-se de que sua potência seja adequada para o ferro.

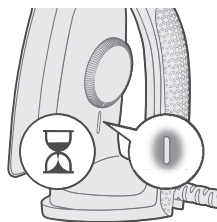

- 4 Aguarde até que o ferro aqueça. A luz indicadora acenderá quando o ferro estiver aquecendo.

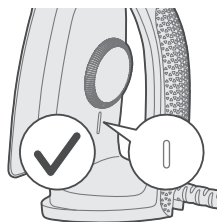

- 5 Assim que a luz indicadora se apagar, o ferro estará pronto para uso.

## Limpeza e manutenção

- 1 Certifique-se de que o ferro não está conectado à tomada elétrica.

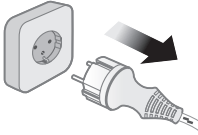

- 2 Certifique-se de que o ferro esteja frio.

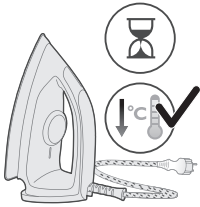

- 3 Limpe a base com um pano úmido.

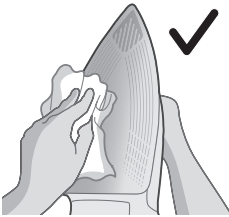

Nota: Mantenha a base lisa e evite o contato direto com objetos metálicos. Nunca use palha de aço, vinagre ou outras substâncias químicas para limpar a base.



- 4 Não lave/limpe o ferro com água corrente, pois isso pode danificar os componentes elétricos no seu interior.



## Armazenamento

- 1 Desconecte o ferro.

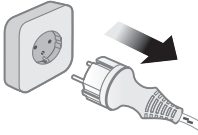

- 2 Deixe o ferro esfriar.

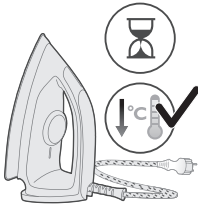

- 3 Enrole o cabo de alimentação de forma organizada antes de guardar o aparelho.

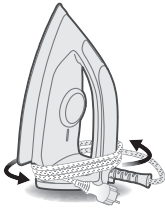

## Giới thiệu

Chúc mừng bạn đã mua hàng và chào mừng bạn đến với Philips! Để có được lợi ích đầy đủ từ sự hỗ trợ do Philips cung cấp, hãy đăng ký sản phẩm tại [www.philips.com/welcome](http://www.philips.com/welcome). Hãy đọc kỹ sách hướng dẫn sử dụng này, tờ rơi thông tin quan trọng và hướng dẫn sử dụng nhanh trước khi bạn sử dụng thiết bị. Hãy cất giữ để tiện tham khảo sau này.

## Tổng quan về sản phẩm

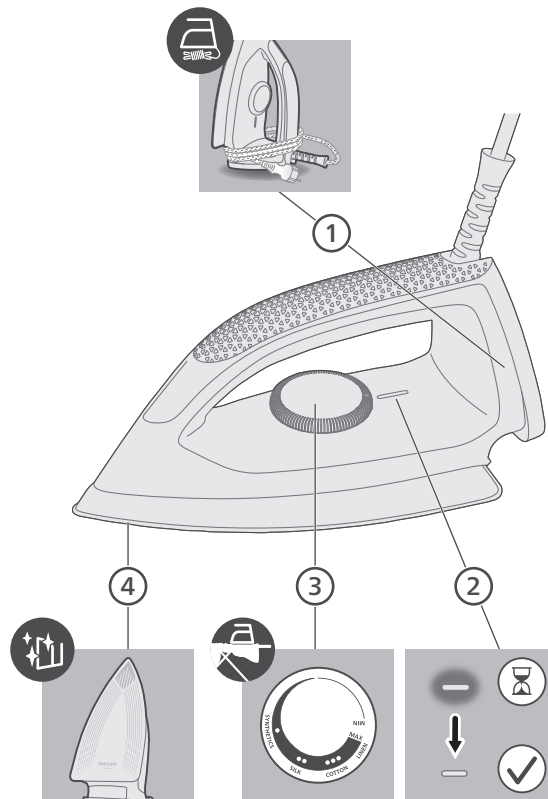

- 1 Ngăn bảo quản dây điện
- 2 Đèn báo
- 3 Núm điều chỉnh nhiệt độ
- 4 Mặt đế

## Cảnh báo bàn ủi nóng



**Thận trọng: Mặt đế và tấm kim loại xung quanh bàn ủi sẽ nóng khi sử dụng.**

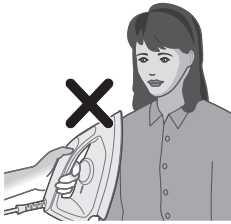

Không đặt bàn ủi hướng về phía bạn hoặc người khác khi đang sử dụng.

## Sử dụng thiết bị

### Cài đặt nhiệt độ



MAX (TÔI ĐÀ)  
LINEN (VẢI LẠNH)



● ● ●  
COTTON (VẢI COTTON)



● ●  
SILK (LỤA)



●  
SYNTHETICS (VẢI SỢI TỔNG HỢP)

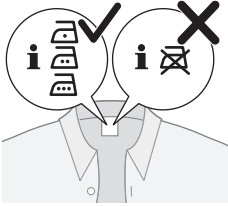

1 Kiểm tra nhãn quần áo để đảm bảo vải có thể ủi được.

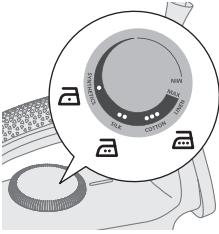

2 Kiểm tra bảng trên để biết cài đặt nhiệt độ chính xác cho vải. Xoay núm điều chỉnh nhiệt độ đến đúng cài đặt - đèn báo sẽ đánh dấu vị trí cài đặt.

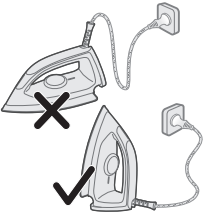

3 Cắm phích cắm vào ổ cắm có nối đất và dựng đứng bàn ủi. Nếu sử dụng phích cắm nối dài, hãy đảm bảo rằng công suất định mức của phích cắm nối dài phù hợp với bàn ủi.

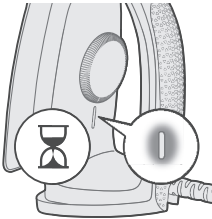

4 Đợi bàn ủi nóng lên. Đèn báo sẽ sáng khi bàn ủi nóng lên.

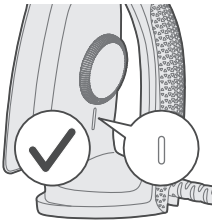

5 Khi đèn báo tắt, bàn ủi đã sẵn sàng để sử dụng.

## Vệ sinh và bảo dưỡng

- 1 Đảm bảo bàn ủi chưa cắm điện.

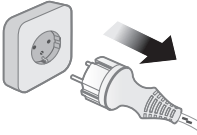

- 2 Đảm bảo bàn ủi đã nguội.

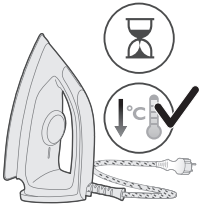

- 3 Lau mặt đế bàn ủi bằng vải ẩm.

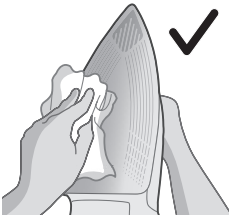

Lưu ý: Để giữ mặt đế bàn ủi trơn nhẵn, tránh va chạm mạnh với các đồ vật kim loại. Tuyệt đối không sử dụng miếng cọ rửa, giấm hoặc các hóa chất khác để làm sạch mặt đế.

- 4 Không rửa/vệ sinh bàn ủi dưới vòi nước chảy vì có thể làm hỏng các bộ phận điện bên trong.



## Bảo quản

1 Rút phích cắm bàn ủi.

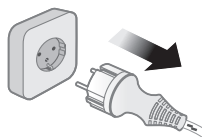

2 Để bàn ủi nguội.

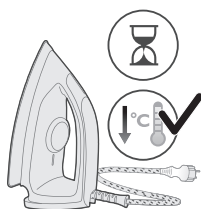

3 Cuộn dây điện gọn gàng trước khi cất giữ.

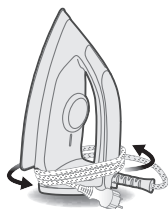



- 1 ที่เก็บสายไฟ
- 2 ไฟแสดงสถานะ
- 3 ปุ่มปรับอุณหภูมิ
- 4 แผ่นความร้อน

## คำเตือนเตารีดร้อน

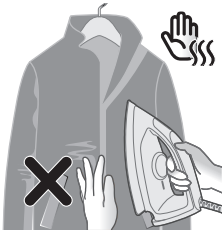

**ข้อควรระวัง:** แผ่นรองเตารีดและแผ่นโลหะรอบๆ จะร้อนเมื่อใช้งาน

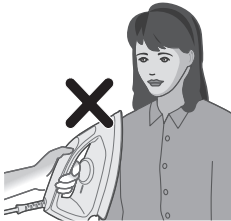

อย่าวางหันเตารีดเข้าหาตัวคุณหรือบุคคลอื่นขณะใช้งาน

## การใช้เครื่อง

### การตั้งอุณหภูมิ

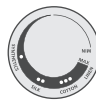

ระดับสูงสุด

ผ้าลินิน



ผ้าฝ้าย



ผ้าไหม



ผ้าใยสังเคราะห์

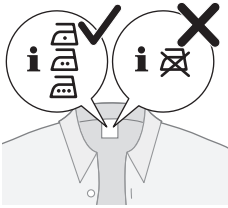

1 ตรวจสอบฉลากบนเสื้อผ้าเพื่อให้แน่ใจว่าผ้านั้นสามารถรีดได้

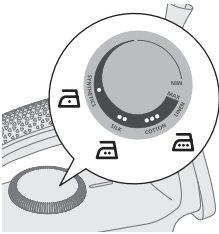

2 ตรวจสอบตารางด้านบนเพื่อดูการตั้งค่าอุณหภูมิที่ถูกต้องสำหรับผ้า หมุนปุ่มปรับอุณหภูมิไปที่ตำแหน่งที่ถูกต้อง - ไฟแสดงสถานะจะระบุตำแหน่งการตั้งค่า

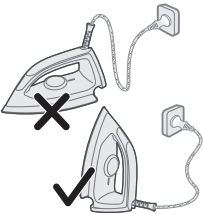

3 เสียบปลั๊กเข้ากับเต้าเสียบติดผนังที่มีสายดินและให้เตารีดวางอยู่บนฐาน หากใช้ปลั๊กต่อพ่วง โปรดตรวจสอบให้แน่ใจว่าปลั๊กต่อพ่วงมีกำลังไฟเหมาะกับเตารีด

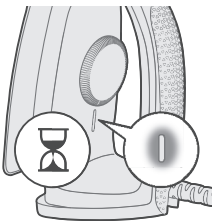

4 รอให้เตารีดร้อนขึ้น  
ไฟแสดงสถานะจะเปิดเมื่อเตารีดกำลังทำความร้อน

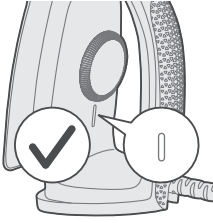

5 เมื่อไฟแสดงสถานะดับ แสดงว่าเตารีดพร้อมใช้งานแล้ว

## การทำความสะอาดและบำรุงรักษา

1 ตรวจสอบให้แน่ใจว่าไม่ได้เสียบปลั๊กเตารีดไว้

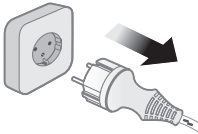

2 ตรวจสอบให้แน่ใจว่าเตารีดเย็นลงแล้ว

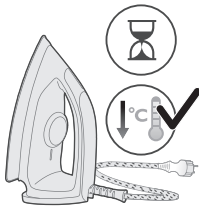

3 ใช้ผ้าหมาดเช็ดแผ่นความร้อน

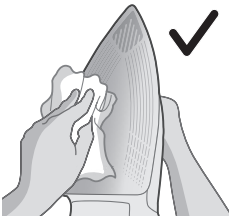

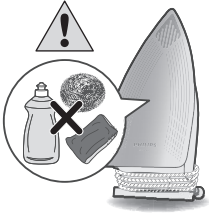

หมายเหตุ: เพื่อรักษาแผ่นความร้อนให้เรียบสั  
น ให้หลีกเลี่ยงการสัมผัสกับวัตถุที่เป็นโลหะ ห้ามใช้แผ่นขัดถู น้ำส้มสายชู  
หรือสารเคมีอื่นๆ ในการทำความสะอาดแผ่นความร้อน



4 ห้ามล้าง/ ทำความสะอาดเตารีดใต้น้ำก๊อก  
เพราะอาจทำให้ส่วนประกอบทางไฟฟ้าภายในได้รับความเสียหาย

## การจัดเก็บ

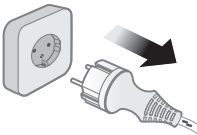

1 ถอดปลั๊กเตารีด

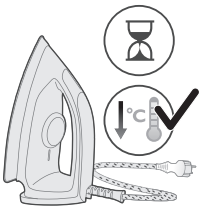

2 ปล่อยให้เตารีดเย็นลง

3 ควรม้วนสายไฟให้เรียบร้อยก่อนจัดเก็บ

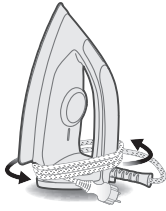



4 底板

## 熨斗高温警告

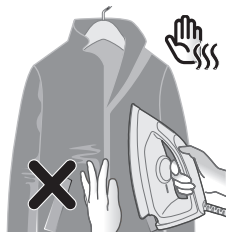

注意：熨斗的底板及其周围金属部分在使用过程中会变热。

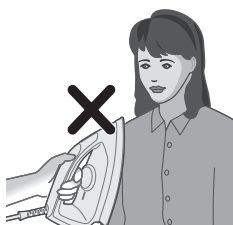

使用过程中切勿将熨斗朝向自己或他人。

## 使用本产品

### 设置温度



	最高 亚麻
	●●● 棉质
	●● 丝质
	● 化纤

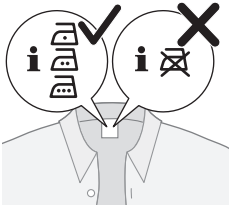

1 检查服装标签，以确保面料可以熨烫。

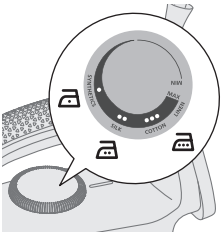

2 请查看上表，选择与织物相匹配的正确温度设置。将温度旋钮调至相应档位 - 指示灯所指的位置即为设定档位。

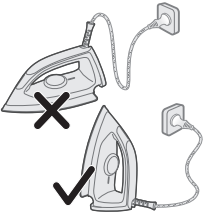

3 将插头插入带接地的墙壁插座，并将熨斗竖直放在后支架上。若使用延长插座，应确保其额定功率符合电熨斗的功率要求。

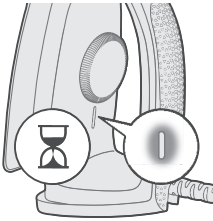

4 请等待电熨斗加热。熨斗在加热时，指示灯将亮起。

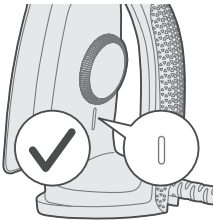

5 当指示灯熄灭时，即表示电熨斗预热已完成，可开始使用。

## 清洁和保养

- 1 确保熨斗电源插头已拔下。

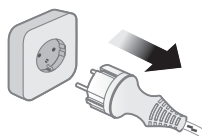

- 2 确保熨斗已完全冷却。

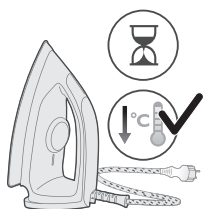

- 3 用湿布擦拭熨斗底板。



注意: 为保持底板光滑, 请避免底板与金属物体碰撞。切勿使用钢丝球、醋或其他化学品清洗底板。



- 4 请勿在流水下冲洗或清洗熨斗, 否则可能会损坏内部电气元件。



## 存储

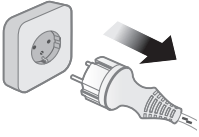

1 拔下熨斗插头。

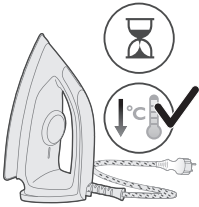

2 让熨斗自然冷却。

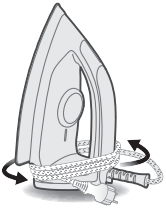

3 存放前请将电源线整齐缠好。

## 簡介

感謝您購買本產品。歡迎來到飛利浦的世界！請至 [www.philips.com/welcome](http://www.philips.com/welcome) 註冊您的產品，以獲得飛利浦提供的完整支援。使用本產品前，請先詳閱本使用手冊、重要資訊手冊及快速入門指南。請妥善保存，以供日後參考。

## 產品概覽

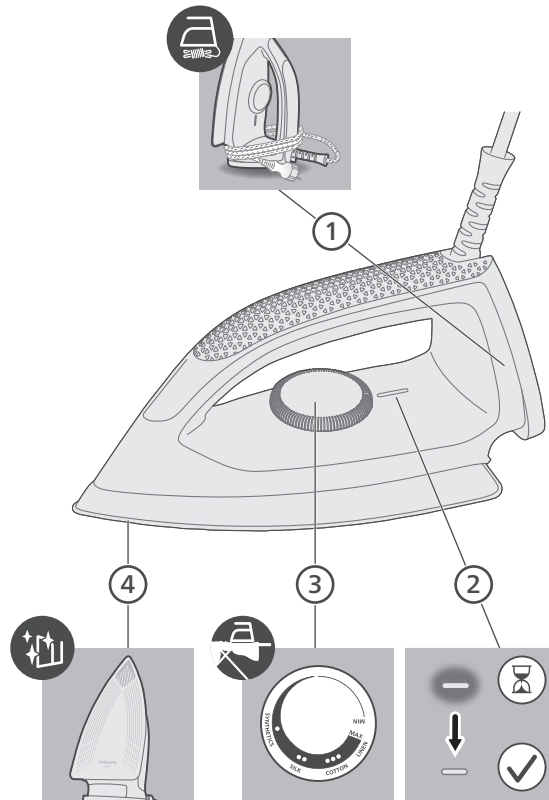

- 1 電線收納
- 2 指示燈
- 3 溫度旋鈕
- 4 底盤

## 高溫熨斗警告



注意：使用時熨斗底盤和周圍的金屬板會很燙。

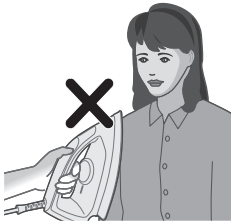

使用時，請勿將熨斗朝向自己或他人。

## 使用產品

### 設定溫度



MAX (最大)  
LINEN (亞麻)



● ● ●  
COTTON (棉)



● ●  
SILK (絲)



●  
SYNTHETICS (合成纖維)

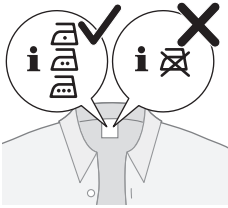

1 請查看衣物標籤以確認布料可熨燙。

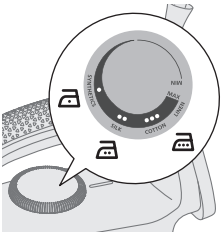

2 請查看上表以瞭解適合布料的正確溫度設定。將溫度旋鈕轉到正確的設定 - 指示燈會標示設定位置。

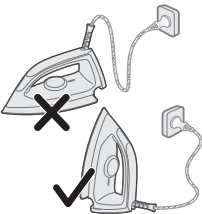

3 插入接地的牆上插座，並讓熨斗直立放置。若使用延長線插頭，請確保延長線插頭的電源功率適用於熨斗。

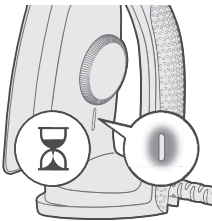

4 請等待熨斗加熱。熨斗加熱時，指示燈會亮起。

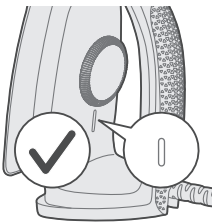

5 指示燈熄滅後，即可開始使用熨斗。

## 清潔與維護

- 1 請確認熨斗未插電。

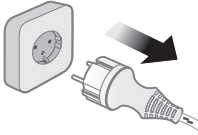

- 2 請確認熨斗已經冷卻。

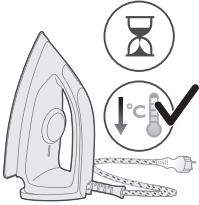

- 3 請用濕布擦拭底盤。

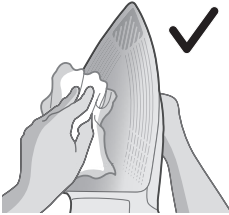

備註：為保持底盤平滑，請避免底盤撞擊金屬物體。切勿使用鋼絲絨、醋或其他的化學物質來清洗底盤。

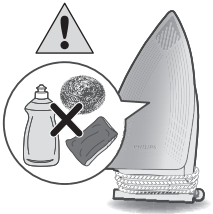

- 4 請勿在流水下清洗/清潔熨斗，以免損壞內部的電子元件。



## 收納

- 1 拔下熨斗插頭。

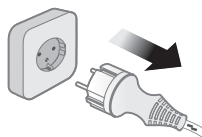

- 2 讓熨斗冷卻。

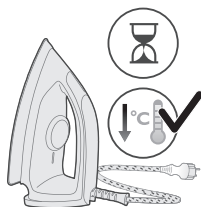

- 3 收納前請將電源線整齊繞好。

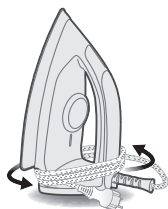

## 소개

필립스 제품을 구입해 주셔서 감사합니다! 필립스가 드리는 지원 혜택을 받으실 수 있도록 [www.philips.com/welcome](http://www.philips.com/welcome)에서 제품을 등록하십시오. 본 제품을 사용하기 전에 이 사용 설명서와 중요 정보 책자, 요약 설명서를 주의 깊게 읽으십시오. 나중에 참조할 수 있도록 이 설명서를 보관하십시오.

## 제품 개요

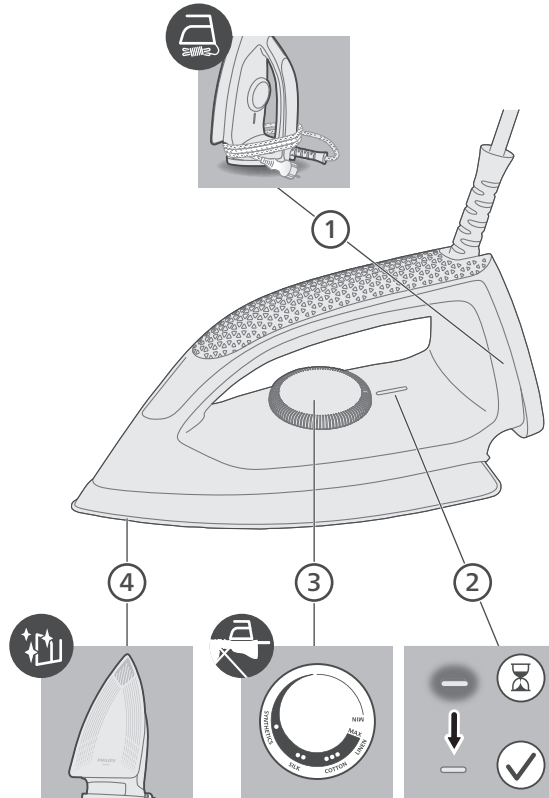

- 1 코드 보관
- 2 표시등
- 3 온도 조절기
- 4 열판

## 뜨거운 다리미 경고



주의: 다리미의 열판과 주변 금속판이 사용 중 뜨거우니 주의하십시오.

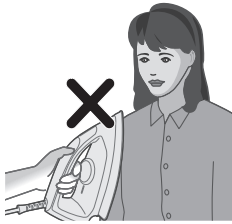

사용 중에는 다리미를 자신이나 다른 사람에게 가까이 대지 마십시오.

## 제품 사용하기

### 온도 설정



	최대 마
	● ● ● 면
	● ● 실크
	● 합성섬유

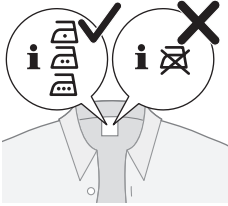

1 옷감에 다림질이 가능한지 확인하려면 의류 라벨을 확인하십시오.

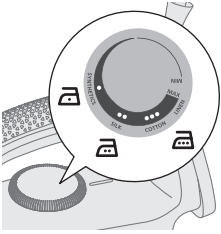

2 위 표를 참조하여 옷감에 맞는 올바른 온도 설정을 확인하십시오. 온도 다이얼을 올바른 설정으로 돌리십시오. 표시등이 설정 위치를 표시합니다.

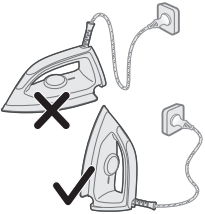

3 접지된 벽면 콘센트에 꽂고 다리미를 세워 두십시오. 연장선을 사용할 경우 정격 전력이 다리미에 적합한지 확인합니다.

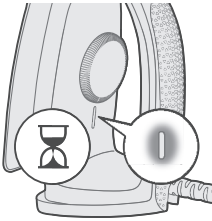

4 다리미가 가열될 때까지 기다립니다. 다리미가 가열되면 표시등이 켜집니다.

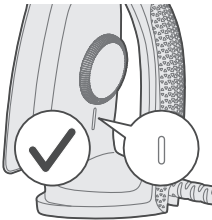

5 표시등이 꺼지면 다리미를 사용할 준비가 된 것입니다.

## 청소 및 유지관리

- 1 다리미가 전원에 연결되지 않도록 합니다.

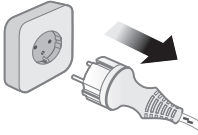

- 2 다리미가 식었는지 확인합니다.

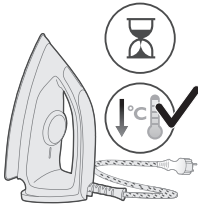

- 3 젖은 천을 사용하여 열판을 닦으십시오.

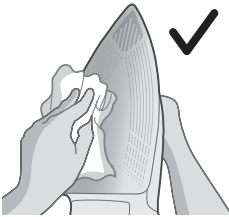

참고: 열판을 매끄럽게 유지하려면, 금속 물질에 긁히지 않도록 주의하십시오. 열판을 닦을 때는 절대 수세미나 식초 또는 기타 화학 약품을 사용하지 마십시오.



- 4 흐르는 물에 다리미를 세척하지 마십시오. 내부 전기 부품이 손상될 수 있습니다.



## 보관

- 1 다리미의 전원을 뽑으십시오.

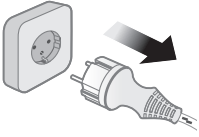

- 2 다리미를 식혀주십시오.

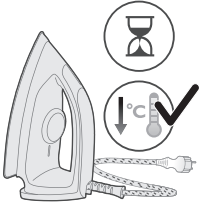

- 3 보관하기 전에 전원 코드를 깔끔하게 감아 주십시오.

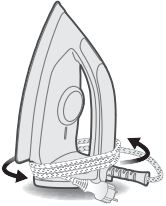

## المقدمة

تهانينا على شرائك المنتج، ومرحبًا بك في Philips! للاستفادة بالكامل من الدعم الذي تقدّمه Philips، سجّل منتجك على [www.philips.com/welcome](http://www.philips.com/welcome). اقرأ دليل المستخدم هنا وكتيّب المعلومات الهامة ودليل البدء السريع بدقة قبل استخدام الجهاز. واحتفظ بكل المستندات للرجوع إليها في المستقبل.

## نظرة عامة حول المنتج

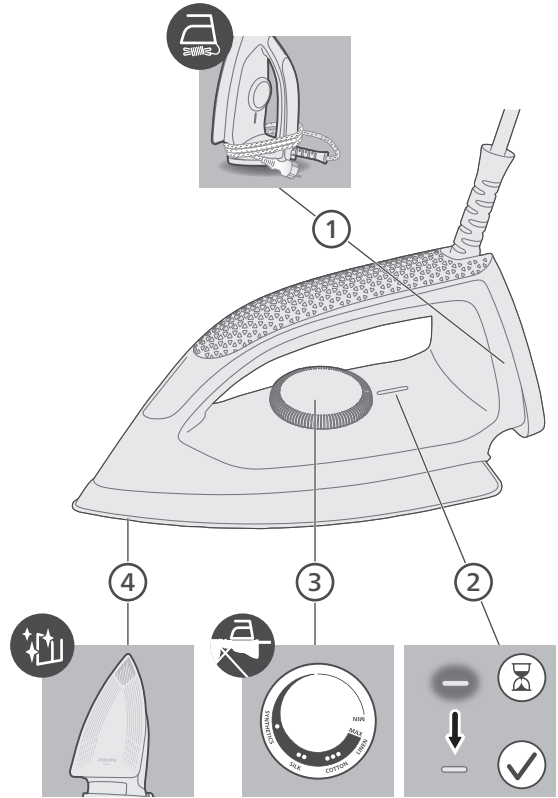

- 1 مخزن الكبل
- 2 ضوء المؤشر
- 3 قرص درجة الحرارة
- 4 قاعدة المكواة

## تحذير من المكواة الساخنة

تنبيه: ستصبح قاعدة المكواة واللوح المعدنية المحيطة بها ساخنة أثناء الاستخدام.

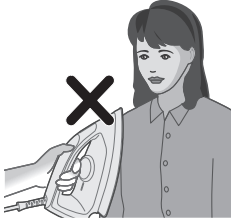

لا توجه المكواة نحوك أو نحو أشخاص آخرين أثناء استخدامها.

## استخدام الجهاز

### تعيين درجة الحرارة



الحد الأقصى	
كتان	
قطن	
حرير	
صناعي	

1 تحقق من الملصق الموجود على الملابس للتأكد من أن القماش قابل للكي.

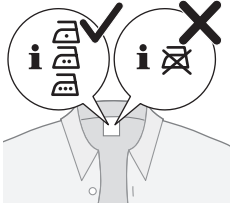

2 تحقق من الجدول أعلاه لتعيين درجة الحرارة المناسبة للقماش. اضبط قرص درجة الحرارة على الإعداد الصحيح. يشير ضوء المؤشر إلى موضع الإعداد.

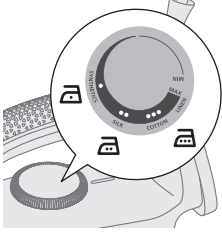

3 اوصل المكواة بمأخذ مؤرض في الحائط وضعها على قاعدتها. إذا كنت تستخدم وصلة تمديد، فتأكد من أن تصنيف الطاقة الخاص بها مناسب للمكواة.

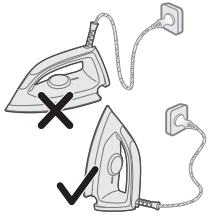

4 انتظر حتى تحمي المكواة. سيضيء ضوء المؤشر عندما تبدأ المكواة بالإحماء.

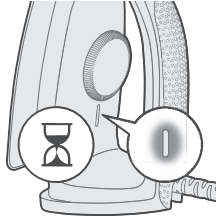

5 عند انطفاء المؤشر، تصبح المكواة جاهزة للاستخدام.

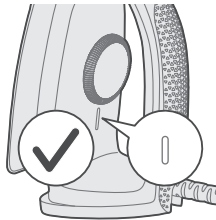

## التنظيف والصيانة

1 تأكد من أن المكواة غير موصولة بمصدر طاقة.

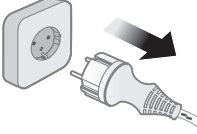

2 تأكد من أن المكواة قد بردت.

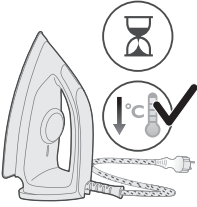

3 امسح قاعدة المكواة بواسطة قطعة قماش رطبة.

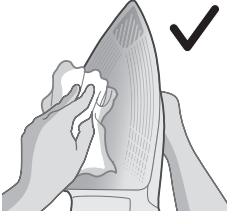

ملاحظة: للحفاظ على نعومة قاعدة المكواة، تجنب ارتطامها بالأغراض المعدنية. لا تستخدم أبداً إسفنجة خشنة أو خلاطاً أو أي مواد كيميائية أخرى لتنظيف قاعدة المكواة.

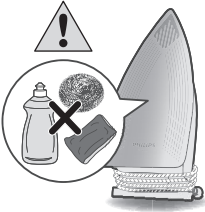

4 لا تغسل/تنظف المكواة باستخدام المياه الجارية، فقد يؤدي ذلك إلى تلف المكونات الكهربائية بداخلها.



## التخزين

1 افصل المكواة عن مصدر الطاقة.

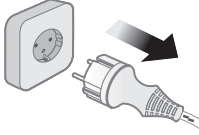

2 دَع المكواة تبرد.

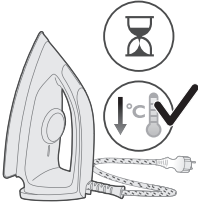

3 قم بلف سلك الطاقة بشكل مرتب قبل تخزينها.

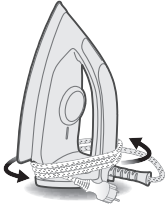

## مقدمه

به دنیای محصولات Philips خوش آمدید. به شما برای خرید این محصول تبریک می‌گوییم! برای استفاده بهینه از خدمات پس از فروش Philips، دستگاه خود را در سایت [www.philips.com/welcome](http://www.philips.com/welcome) ثبت نام کنید. این راهنمای کاربر، برشور اطلاعات مهم و راهنمای شروع سریع را قبل از استفاده از دستگاه به دقت مطالعه کنید. آنها را برای مراجعات بعدی نزد خود نگه دارید.

## نمای کلی دستگاه

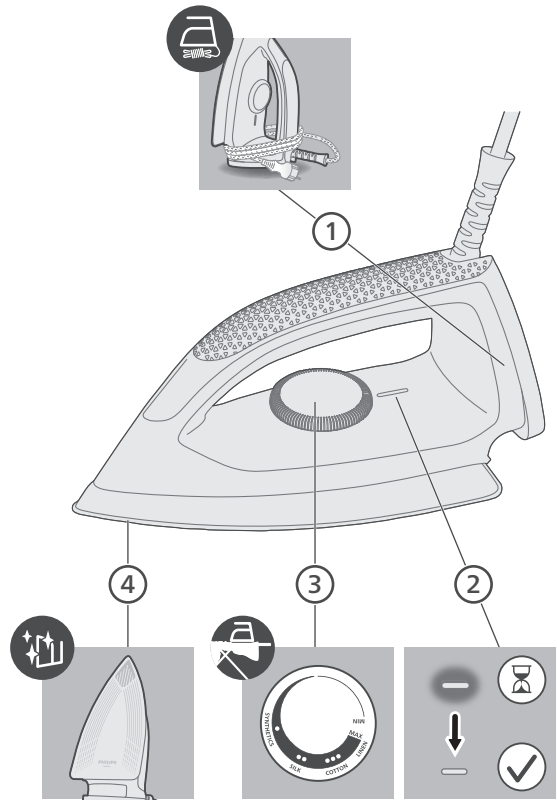

- 1 محل نگهداری سیم
- 2 چراغ نشانگر
- 3 پیچ دما
- 4 کف اتو

## هشدار داغ بودن اتو

احتیاط: هنگام استفاده از اتو، کف اتو و صفحه فلزی اطراف آن داغ می‌شوند.

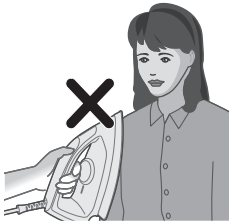

هنگام استفاده، از قرار دادن اتو به طرف خودتان یا دیگران خودداری کنید.

## استفاده از دستگاه

### تنظیم دما



حداکثر

نخی



کتانی



اپریشمی



الیاف مصنوعی

1 برای اطمینان از قابل اتو پارچه برچسب لباس را بررسی کنید.

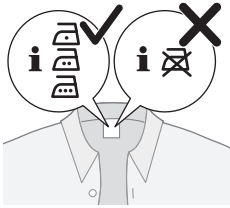

2 برای تنظیم دمای صحیح برای هر پارچه، جدول بالا را بررسی کنید. پیچ دما را روی تنظیم صحیح بگذارید - چراغ نشانگر وضعیت تنظیم را نشان می‌دهد.

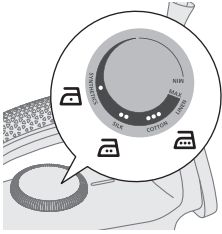

3 دوشاخه را به پریز برق دارای اتصال زمین وصل کنید و اجازه دهید اتو روی پایه خود قرار گیرد. در صورت استفاده از دوشاخه اضافی، مطمئن شوید که توان دوشاخه اضافی برای اتو مناسب است.

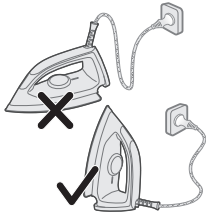

4 صبر کنید تا اتو گرم شود. هنگام داغ شدن اتو، چراغ نشانگر روشن می‌شود.

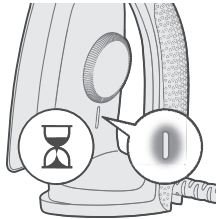

5 زمانی که چراغ نشانگر خاموش شد، اتو آماده استفاده است.

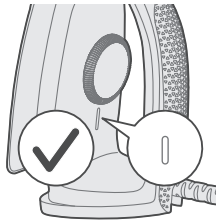

## تمیز کردن و مراقبت از دستگاه

1 مطمئن شوید اتو در پریز نباشد.

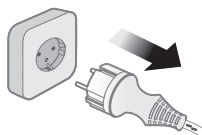

2 مطمئن شوید اتو خنک شده است.

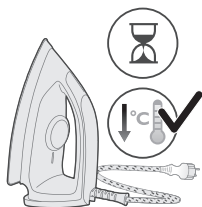

3 کف اتو را با یک پارچه مرطوب تمیز کنید.



توجه: برای خنثی برداشتن صفحه کف اتو، از تماس فلزات و اشیای سخت با کف اتو خودداری کنید. هرگز از یک پد ساینشی، سرکه یا مواد شیمیایی دیگر برای تمیز کردن صفحه صاف کف اتو استفاده نکنید.



4 اتو را زیر آب جاری نشویید/تمیز نکنید، زیرا ممکن است به قطعات الکتریکی داخلی آن آسیب وارد شود.



## نگهداری

1 اتو را از برق بکشید.

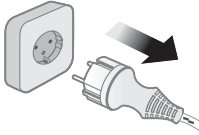

2 اجازه دهید اتو خنک شود.

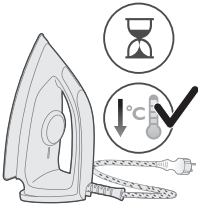

3 قبل از کنار گذاشتن دستگاه، سیم را به طور مرتب در محل نگهداری سیم جمع کنید.

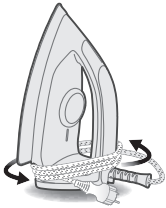

PHILIPS and the Philips Shield Emblem are registered trademarks of Koninklijke Philips N.V. and are used under license.

This product has been manufactured by and is sold under the responsibility of Versuni Holding B.V., and Versuni Holding B.V. is the warrantor in relation to this product.

2025 © Versuni Holding B.V.

642001029572 (09/2025)

