

Clip Counter Flex

Assembly Instructions

Tools Required:

- Socket Driver

Sheet Code: BP-IM-139_REV0

Release Date: 07/11/2025

Copyright 2025 SpotSpot Ltd. (T/A Bouncepad) all rights reserved. Confidential, no part of this publication may be reproduced or transmitted in any form without the written permission of the copyright holder.

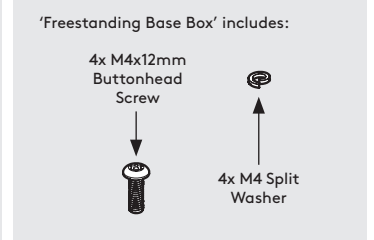
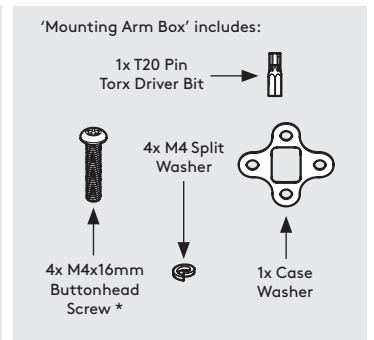
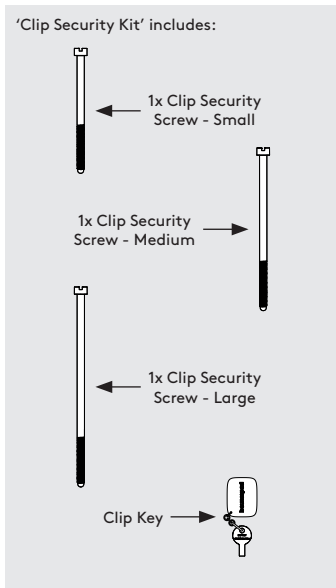
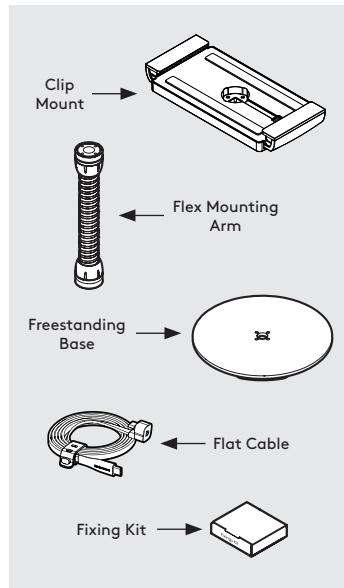

In the Box



Fixings List

Due to the modular nature of our product range you may receive additional fixings in the fixings kit. * Previous models may have been supplied with 20mm.

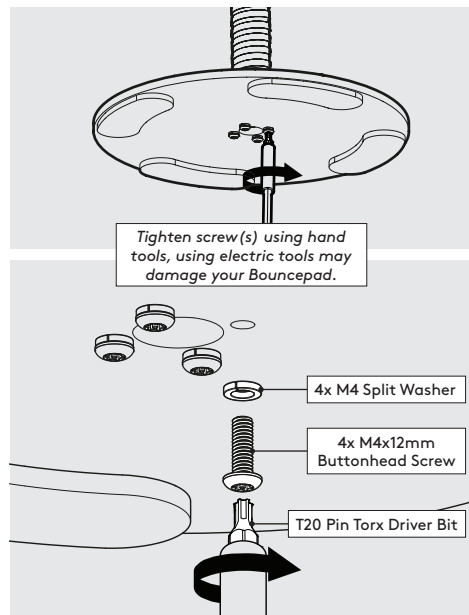

1 Locate & secure the Flex Mounting Arm to the Freestanding Base.

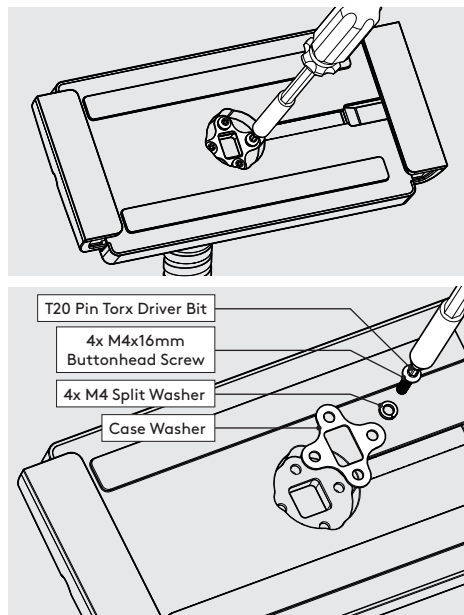

3 Attach the Clip Mount to the Flex as shown.

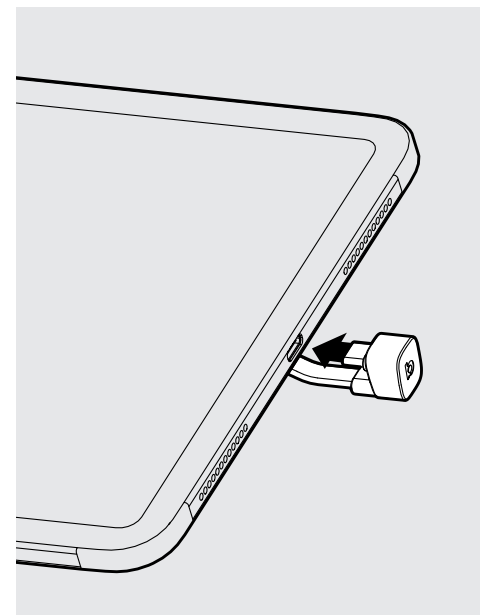

4 Attach the Flat Cable to the Tablet with the U-Bend Head.

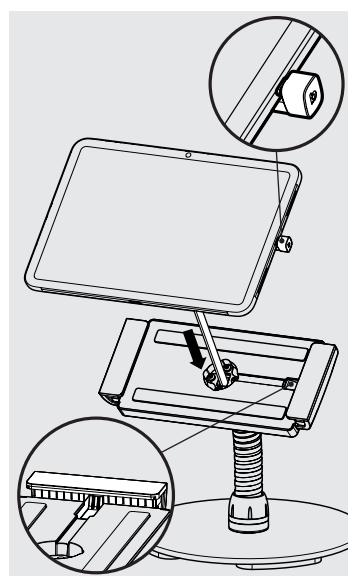

5 Feed the Flat Cable into the Assembly.

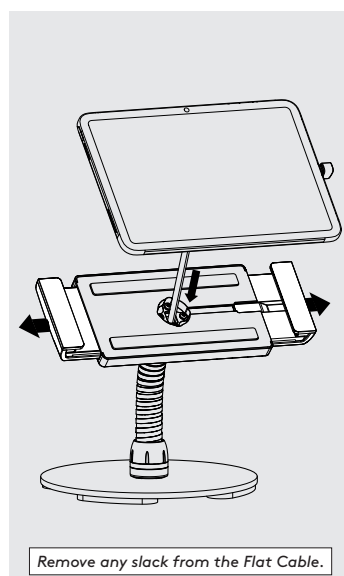

6 Open the Clip Mount Jaws & Lower the Tablet.

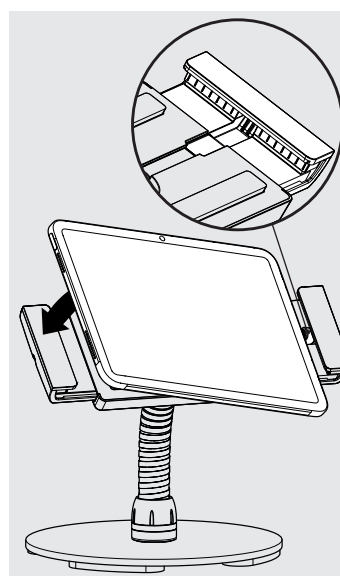

7 Locate the Flat Cable's U-Bend Head into the slot & place the Tablet into the Clip Mount.

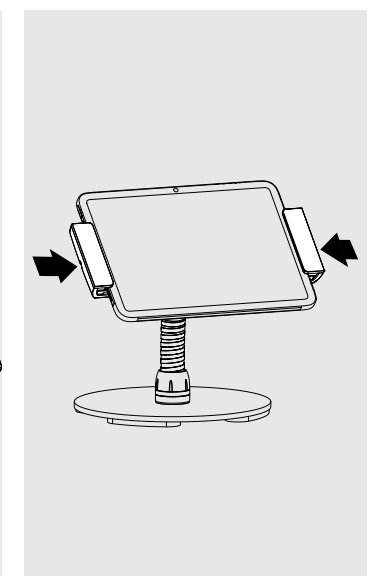

8 Close the Clip Mount Jaws around the Tablet.

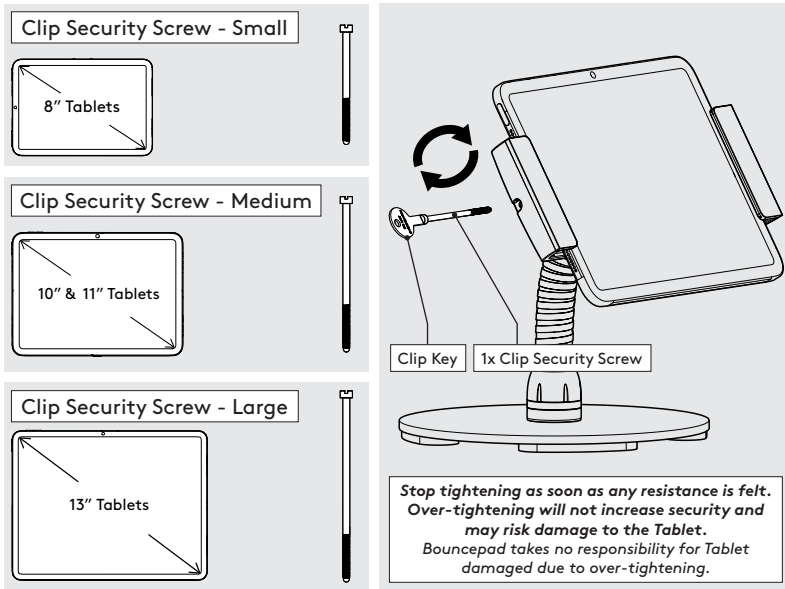

9 Secure the Clip Mount Jaws with the correct Clip Security Screw. This must only be done using the Clip Key.

