

Clip Twist

Assembly Instructions

Tools Required:

- Pencil
- Electric Drill
- 7mm Spanner **or adjustable spanner*
- 5.0mm Drillbit **if fixing from below*
- 2.5mm Drillbit **if fixing from above*
- 16mm Holesaw **if routing the tablet cable through your mounting surface*
- Socket Driver

Tighten screw(s) using hand tools, using electric tools may damage your Bouncepad.

Sheet Code: BP-IM-149_REV0

Release Date: 13/02/2026

Copyright 2026 SpotSpot Ltd. (T/A Bouncepad) all rights reserved. Confidential, no part of this publication may be reproduced or transmitted in any form without the written permission of the copyright holder.

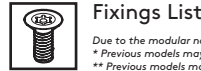
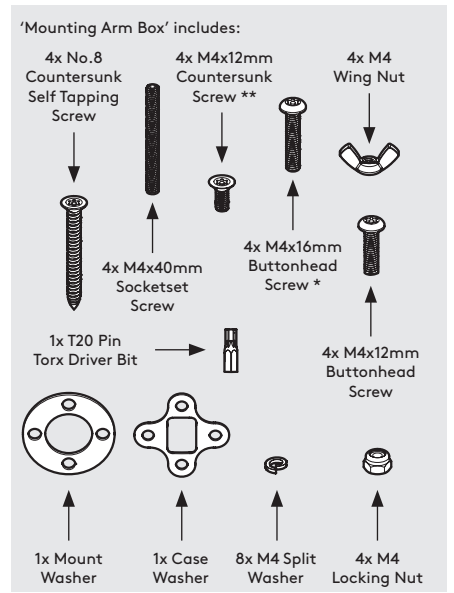
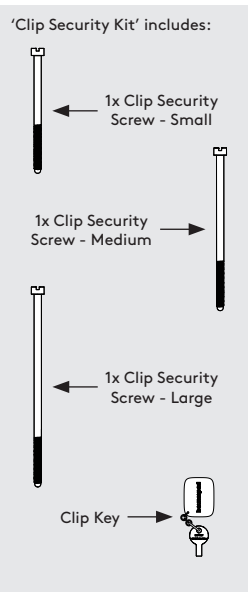
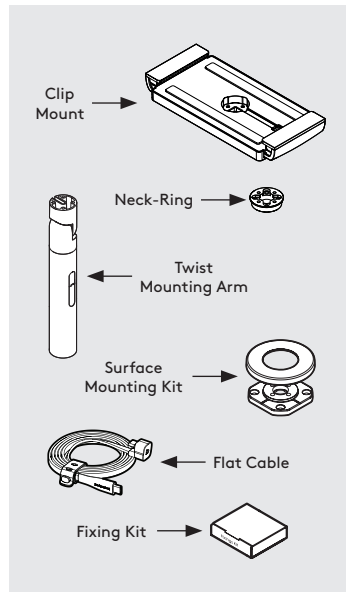

Due to the modular nature of our product range you may receive additional fixings in the fixings kit.
* Previous models may have been supplied with 20mm.
** Previous models may have been supplied with 10mm.

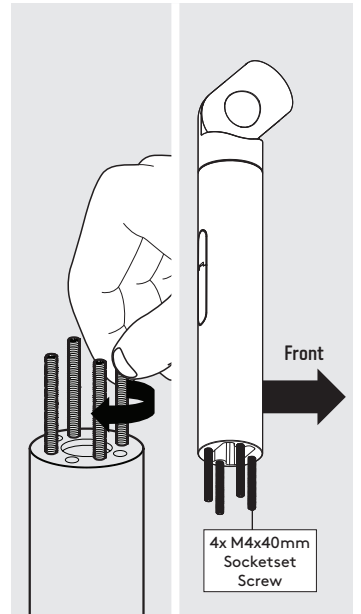
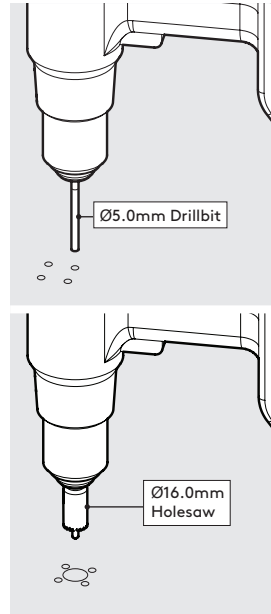
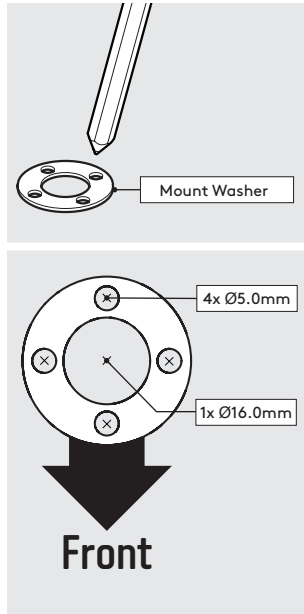
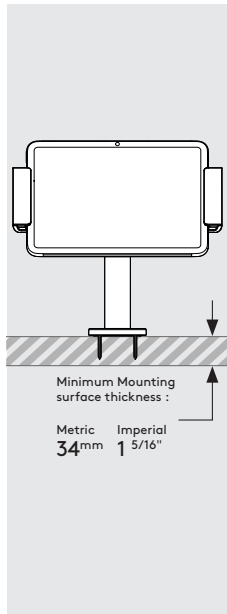
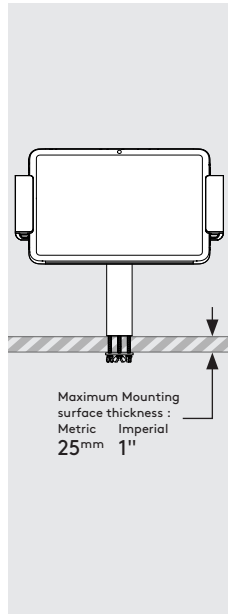

A Follow steps A if "Fixing from below".

B Follow steps B if "Fixing from Above".

A1 Using the Mount Washer, mark the drill hole locations.

A2 Drill each hole - using the specified drill size.

A3 Locate & screw the Socket Screws into the Twist as shown.

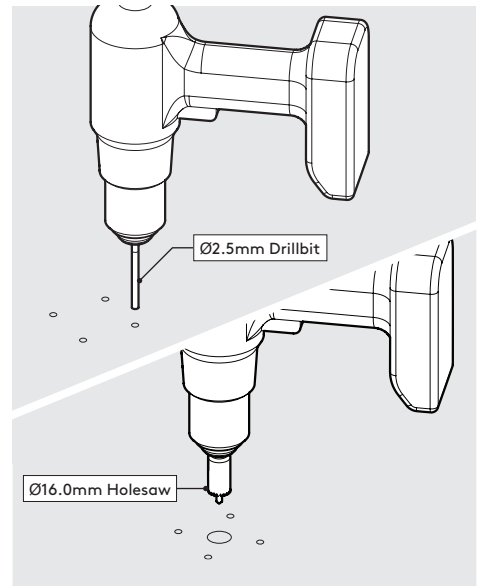
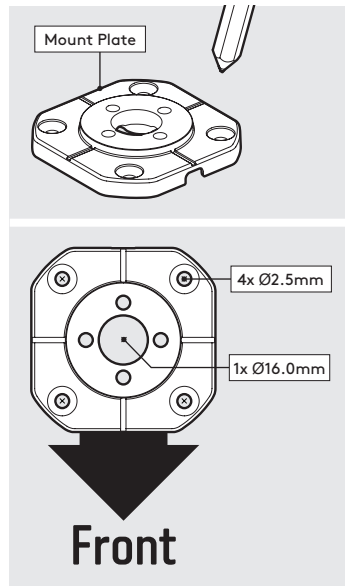
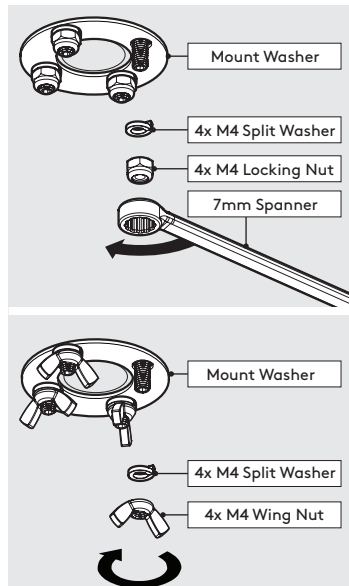

A4 Secure the Twist to the surface. Locking Nuts offer higher security.

A5 Go to step 1.

B1 Using the Mount Plate, mark the drill hole locations as shown.

B2 Drill each hole - using the specified drill sizes.

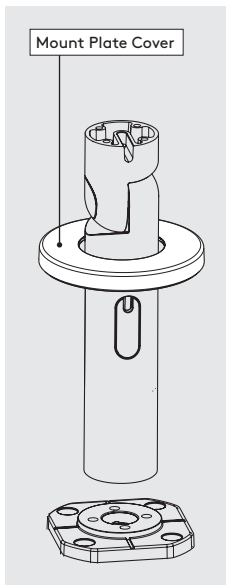

B3 Locate the Cover onto the Twist.

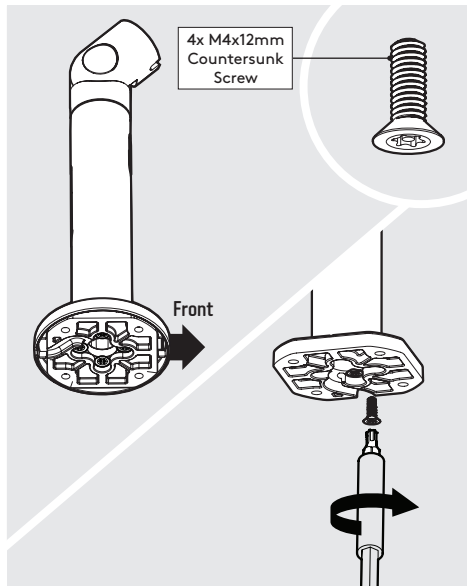

B4 Join the Twist & Mount Plate in the orientation shown.

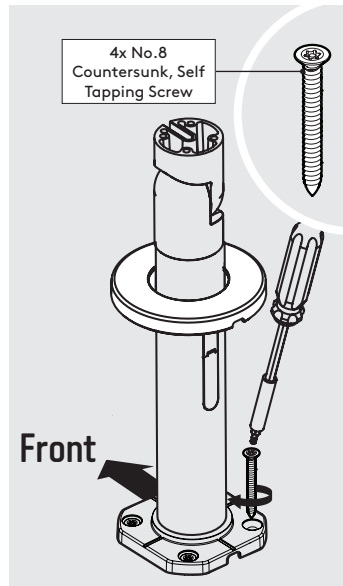

B5 Secure the Twist to the surface with the 4x Countersunk Fixings.

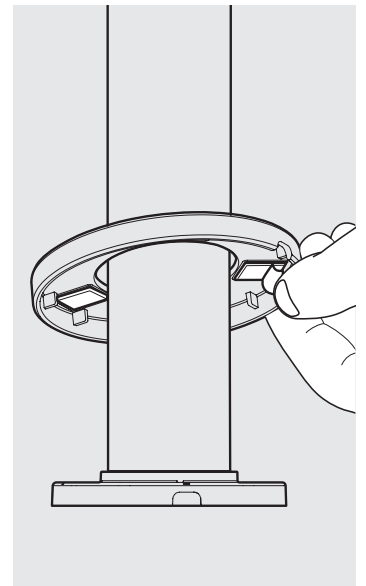

B6 Adhere the Mount Cover onto the Mount Plate with the adhesive tabs.

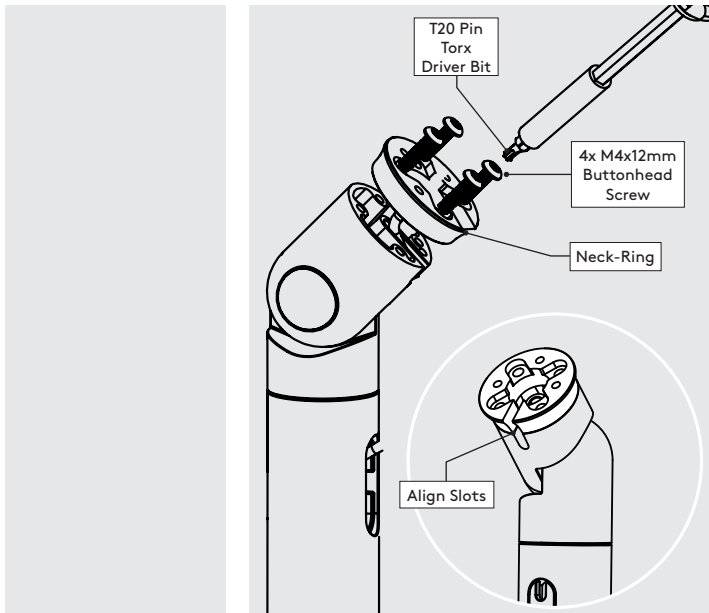

B7 Go to step 1. **1** Attach Neck-Ring to the Twist with 4x M4x12 Buttonhead Screws as shown. The slots must be aligned.

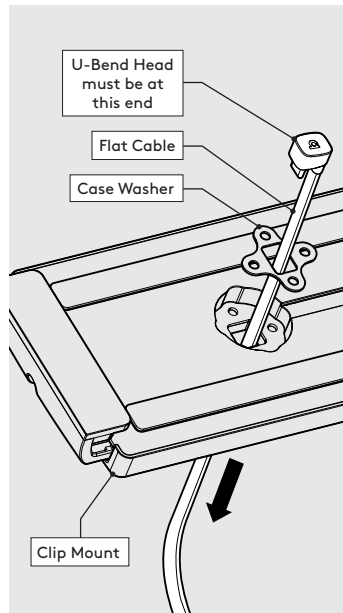

2 Feed the Flat Cable through the Case Washer & Clip Mount as shown.

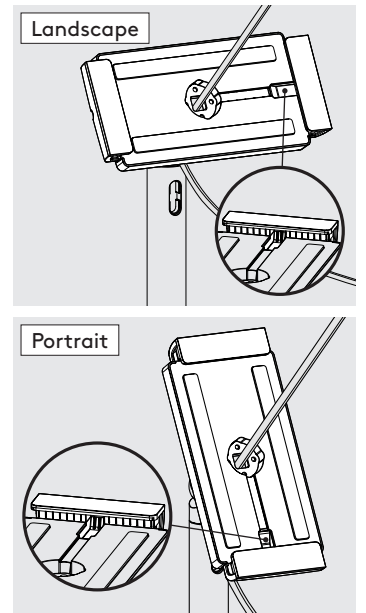

3 Locate the Clip Mount onto the Twist in your chosen orientation.

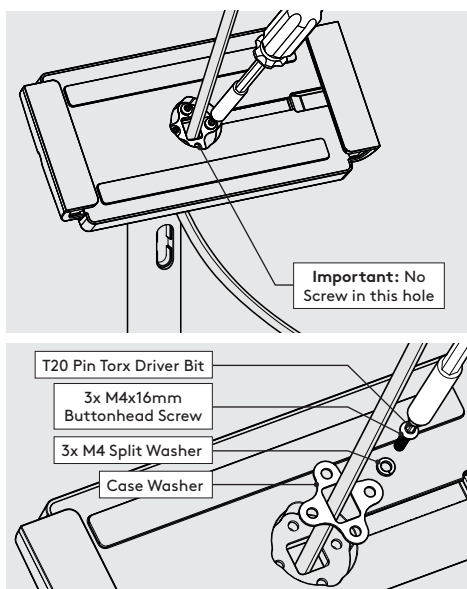

4 Attach the Clip Mount to the Neck-Ring as shown.

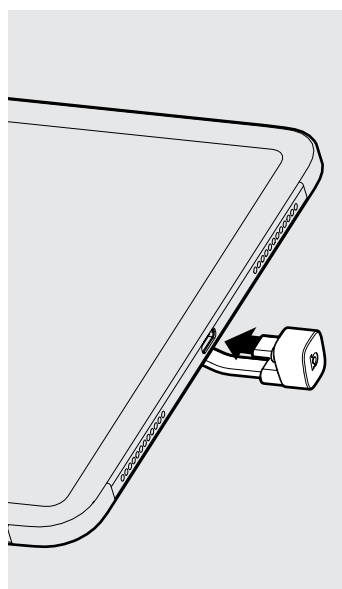

5 Attach the Flat Cable to the Tablet with the U-Bend Head.

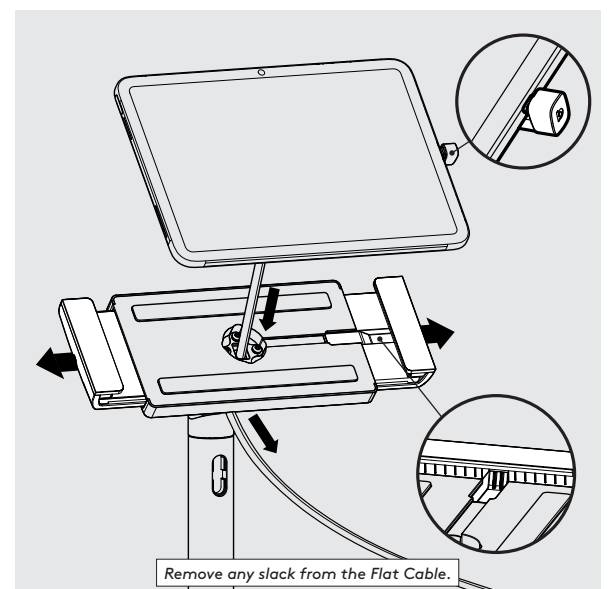

6 Open the Clip Mount Jaws & Lower the Tablet

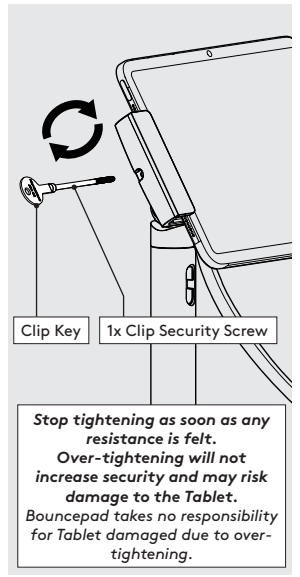
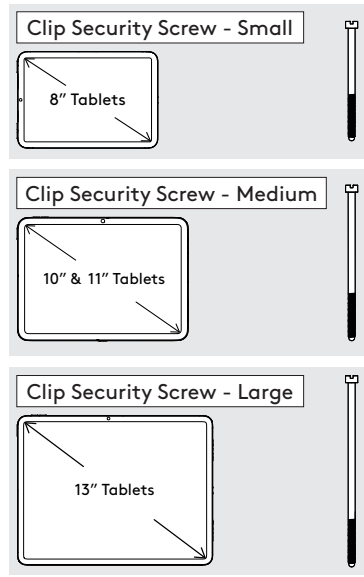
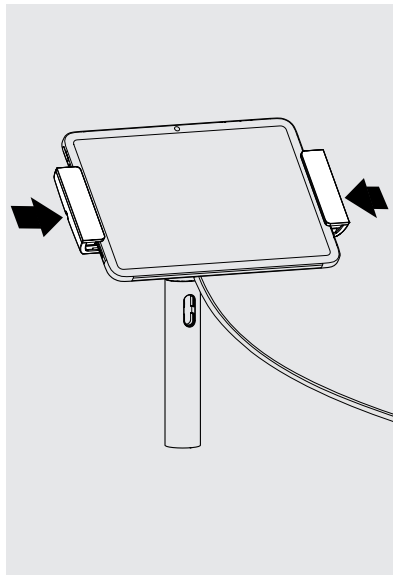
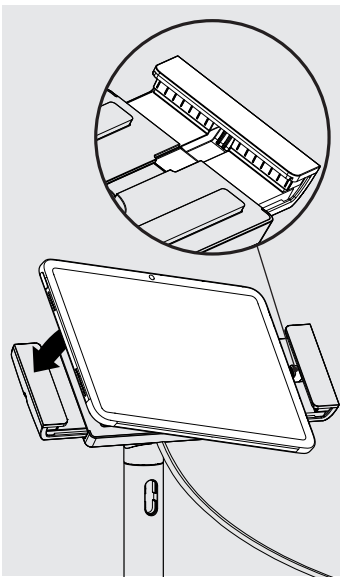

7 Locate the Flat Cable's U-Bend Head into the slot & place the Tablet into the Clip Mount.

8 Close the Clip Mount Jaws around the Tablet.

9 Secure the Clip Mount Jaws with the correct Clip Security Screw. This must only be done using the Clip Key.

Stop tightening as soon as any resistance is felt. Over-tightening will not increase security and may risk damage to the Tablet. Bouncepad takes no responsibility for Tablet damaged due to over-tightening.

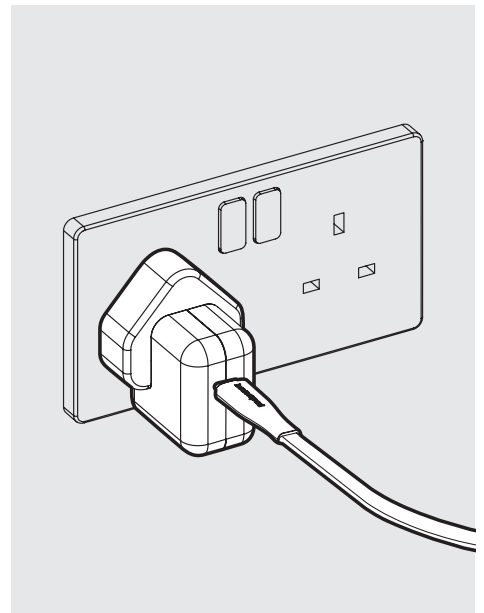
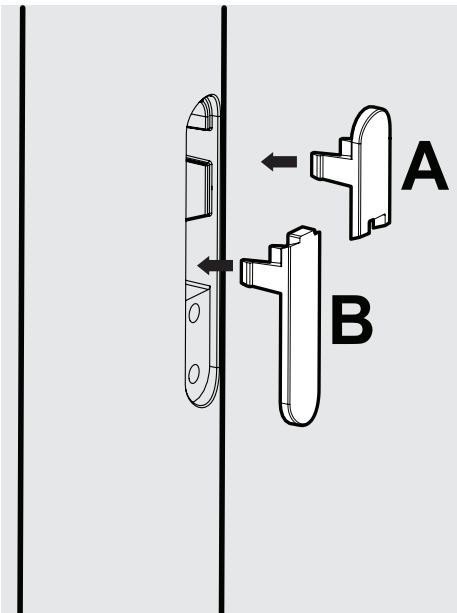
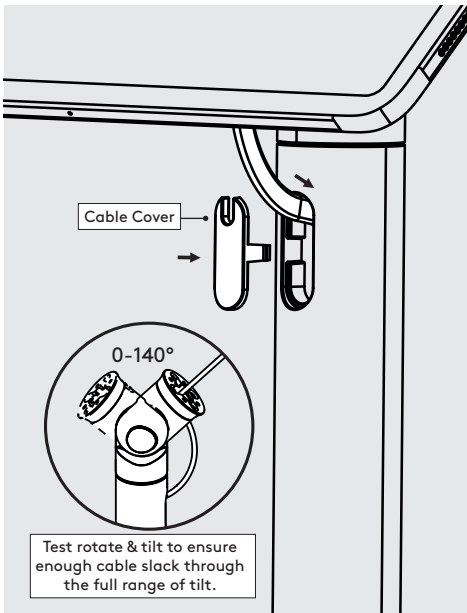

10 Feed Flat Cable into the Cable Slot. Ensure there is adequate slack before attaching Cable Cover.

11 Fit Second Screen Attachment Covers. Fit cover 'B' before cover 'A'.

12 Connect the Flat Cable to a Mains Power Source.

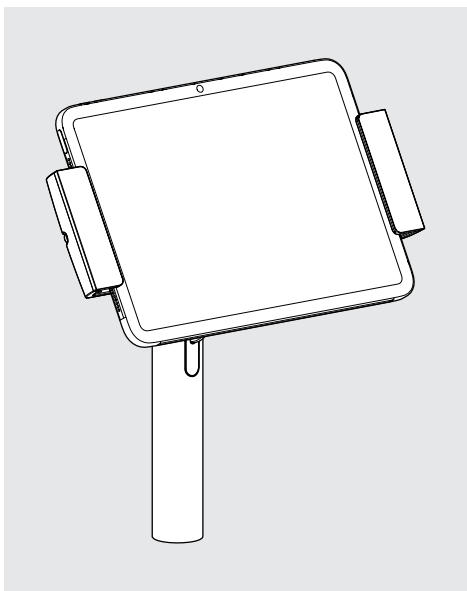

13 Installation is now complete.