

# INSTRUCTIONS FOR USE

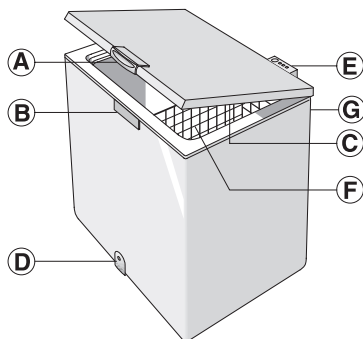

- A. Lid Handle.
- B. Lock (if provided).
- C. Seal.
- D. Defrost water drain plug (depending on model).
- E. Control panel.
- F. Basket (depending on model).
- G. Condenser (located at the rear).

## INSTALLATION

- Refer to chapter “Before using the appliance”.
- **Unpack the appliance.**
- **Remove the 4 protection pieces inserted between lid and appliance.**
- **Warning: two of the four protection pieces must be fitted in the seat of the condenser plastic supports, located at the rear of the product.**

This is necessary to ensure the correct distance from the wall.

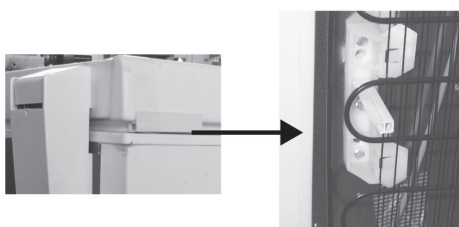

- **Clean the inside of the appliance before using it.**

- Ensure that the defrosting water drainage plug (if provided) is correctly positioned (D).
- For best operation of the appliance and in order to avoid damage when the lid is opened, leave a space of at least 7 cm from the rear wall and 7 cm at the sides.
- Fit the accessories (if provided).

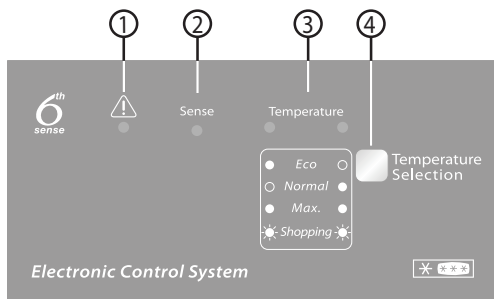

- 1. Red LED:** when flashing, it indicates that an alarm condition is present (see “TROUBLESHOOTING GUIDE”)
- 2. Blue LED:** the function “6th Sense” is automatically activated and does not need to be selected by the user, therefore **the blue LED (2) “Sense” always remains on**. For more technical details, refer to paragraph “6th Sense function”.
- 3. Green LEDs:** they indicate that the appliance is in operation, and the temperature has been set.
- 4. Temperature setting button:** to adjust the set temperature and to activate/deactivate the fast freezing operations.

## Switching on the appliance

- Plug in the appliance.
- The green LED lights up (“Normal”).
- The blue LED lights up (“Sense”).
- The red LED flashes to indicate that the temperature inside the appliance is not yet sufficiently low for food storage. The red LED will normally switch off within the first six hours after the appliance is switched on.
- Place food inside the product only when the red LED has switched off.

## Note:

As the seal is tight, the appliance lid cannot be reopened immediately after closing. Wait a few minutes before re-opening the lid of the appliance.

# INSTRUCTIONS FOR USE

## Temperature adjustment

Use the key (4) to select the desired temperature. To adjust the internal temperature, proceed as follows:

- Repeatedly press the key (4). Each time the key is pressed, the set temperature is updated, displaying the "Normal", "Eco" and "Max" values in succession.
- Select "Max" for a colder storage temperature.
- With partial loads "Eco" is recommended: this setting will optimise energy consumption.

The green indicator lamps (3) indicate the selected setting according to the following diagram:



**Eco:** least cold temperature (left indicator lamp lit).

**Normal:** intermediate temperature (right indicator lamp lit).

**Max.:** extra low temperature (both indicator lamps lit).

**Shopping:** Fast Freezing (both indicator lamps lit). See section "Freezing fresh food".

**Note:** The settings will be saved in the memory even if a power cut occurs. The time needed for the temperature inside the freezer to reach the set value, can vary depending on climatic conditions and the set temperature itself.

## 6th Sense" Function

The "6th Sense" function is always active to control the internal temperature of the appliance and guarantee the optimum conditions.

It automatically intervenes in the following cases:

### • door opening

This function activates every time the opening of the door changes the internal temperature of the appliance. The function remains active for the time needed to reinstate optimum operating conditions.

### • storing food inside the freezer

This function activates every time significant quantities of food are introduced. It remains active for the time needed to reinstate optimum freezing conditions of the food introduced, ensuring the best compromise between the quality of the freezing process and energy consumption.

**Note:** The duration of the "6th Sense" function is set automatically, and may vary depending on the way the product is used.

## FREEZING FOOD

### Preparation of fresh food for freezing

- Before freezing, wrap and seal fresh food in: aluminium foil, cling film, air and water-tight plastic bags, polyethylene containers with lids, provided they are suitable for freezing foods.
- Food must be fresh, mature and of prime quality in order

to obtain high quality frozen food.

- Fresh vegetables and fruit should preferably be frozen as soon as they are picked to maintain the full original nutritional value, consistency, colour and flavour.
- Always leave hot food to cool before placing in the appliance.

### Freezing fresh food

- Place foods to be frozen in direct contact with the walls of appliance:
  - A) - foods to be frozen,
  - B) - foods already frozen.
- Avoid placing foods to be frozen in direct contact with food already frozen.
- For best and fastest freezing, foods should be split into small portions; this will also be useful when the frozen items are to be used.
- If minimum quantities of food are introduced (up to 1/4 of the maximum freezing power stated on the rating plate), the operation of the appliance will be controlled automatically by the "6th Sense" function without any need for intervention from the user.
- When freezing higher quantities of food, up to the maximum freezing capacity of the appliance, indicated on the rating plated, proceed as follows:

1. At least 24 hours before storing fresh foods inside the product for freezing, activate the fast freezing function by pressing (4) for approximately 3 seconds. The green LEDs (3) flash in sequence.
2. Introduce the food to freeze inside the appliance, and keep the door of the appliance closed for 24 hours. After this period the food will be frozen.

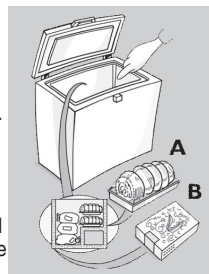

The fast freezing function can be deactivated manually by pressing (4).

If the fast freeze function is not manually deactivated, it will be automatically deactivated by the appliance after 50 hours.

# INSTRUCTIONS FOR USE

## FOOD STORAGE

Refer to the table on the appliance.



### Classification of frozen foods

Put the frozen products into the appliance and classify them; The storage date should be indicated on the packs, to allow use within expiry dates.

### Advice for storing frozen food

When purchasing frozen food products:

- Ensure that the packaging is not damaged (frozen food in damaged packaging may have deteriorated). If the package is swollen or has damp patches, it may not have been stored under optimal conditions and defrosting may have already begun.

MONTHS	FOOD
1-3	
4-7	
8-12	

- When shopping, leave frozen food purchases until last and transport the products in a thermally insulated cool bag.
- Once at home, place the frozen foods immediately in the appliance.
- Avoid, or reduce temperature variations to the minimum. Respect the best-before date on the package.
- Always observe the storage information on the package.

### Note:

**Eat fully or partially defrosted foods immediately. Do not refreeze unless the food is cooked after it has thawed. Once cooked, the thawed food can be refrozen.**

### If there is a long power failure:

- **Do not open the appliance lid except to place ice packs (if provided) over the frozen foods on the right and left of the appliance. This will slow down the rise in temperature.**

## DEFROSTING THE APPLIANCE

The appliance should be defrosted when the thickness of ice on the walls reaches 5-6 mm.

- Disconnect the appliance from the mains power supply.
- Remove the packs of food from the appliance and wrap them close together in newspaper and store in a very cool place or thermally insulated bag.
- Leave the appliance lid open.
- Remove the internal defrost water drain plug (depending on model).
- Remove the external defrost water drain plug (depending on model) and reposition it as shown in the figure.
- Place a bowl beneath the drainage channel to collect the residual water. If available, use the divider.
- Speed up defrosting by using a spatula to detach the ice from the appliance walls.
- **Remove the ice from the bottom of the appliance.**
- **In order to avoid permanent damage to the appliance interior, do not use pointed or sharp metal instruments for removing the ice.**
- **Do not use abrasive products or heat up the interior artificially.**
- **Dry the interior of the appliance thoroughly.**
- On completion of the defrosting, refit the plug.

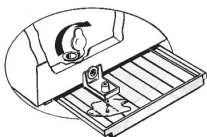
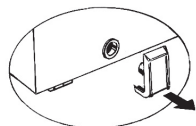

same wattage and voltage.

- Refit the diffuser and plug in the appliance.

## TROUBLESHOOTING GUIDE

### 1. The red LED flashes.

- Is there a power failure?
- Is a defrosting operation in progress?
- Has fresh food recently been introduced?
- Is the appliance lid properly closed?
- Is the appliance placed near a heat source?
- Are the ventilation grille and condenser clean?

### 2. All LEDs flash at the same time.

- Contact the After-Sales Service.

### 3. The appliance is too noisy.

- Is the appliance perfectly horizontal?
- Is the appliance in contact with other furniture or objects that may cause vibrations?
- Has the packaging been removed from under the appliance?

**Note:** Gurgling noises from the refrigerating circuit after the compressor cuts out are perfectly normal.

### 4. All LEDs are off and the product is not working.

- Is there a power failure?
- Is the plug properly inserted in the socket?
- Is the electric cable intact?

### 5. All LEDs are off and the product is working.

- Contact the After-Sales Service.

### 6. The compressor runs continuously.

- Have hot foods been put in the appliance?
- Has the appliance lid been left open for a long time?
- Is the appliance placed in a very warm room or near heat sources?
- Has the fast freeze function been activated? (The green LEDs flash alternatively)

### 7. Too much ice on the upper edge.

- Are the defrost water drainage plugs correctly positioned?
- Is the appliance lid properly closed?
- Is the appliance lid seal damaged or deformed? (See

## CHANGING THE LID LIGHT BULB (if provided)

- Disconnect the appliance from the mains power supply.
- Remove the diffuser by following the sequence of steps shown in the figure.
- Unscrew the light bulb and replace it with an identical bulb of the

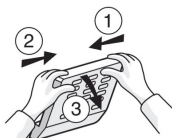

# INSTRUCTIONS FOR USE

- chapter "Installation")
  - Have the 4 protection pieces been removed? (See chapter "Installation")
- 8. Formation of condensate on the external walls of the appliance.**
- It is normal for condensation to form under certain

atmospheric conditions (humidity above 85%) or if the appliance is located in a damp or poorly ventilated room. The performance of the appliance is in no way affected.

**9. The layer of ice on the internal walls of the appliance is not uniform.**

- This phenomenon is quite normal.

## AFTER-SALES SERVICE

### Before contacting After-Sales Service:

1. See if you can solve the problem yourself.
2. Switch the appliance on again to see if the problem has been solved. If it has not, disconnect the appliance from the power supply and wait for about an hour before switching on again.
3. If the problem persists after this course of action, contact After-Sales Service.

### Specify:

- the nature of the fault,
- the model,
- the service number (the number after the word SERVICE on the rating plate on the rear of the appliance)
- your full address,
- your telephone number and area code.

**SERVICE** 0000 000 00000



## ELECTRICAL CONNECTION FOR GREAT BRITAIN AND IRELAND ONLY

**Warning – this appliance must be earthed.**

### Fuse replacement

If the mains lead of this appliance is fitted with a BS 1363A 13amp fused plug, to change a fuse in this type of plug use an A.S.T.A. approved fuse to BS 1362 type and proceed as follows:

1. Remove the fuse cover (A) and fuse (B).
2. Fit replacement 13A fuse into fuse cover.
3. Refit both into plug.

### Important:

The fuse cover must be refitted when changing a fuse and if the fuse cover is lost the plug must not be used until a correct replacement is fitted.

Correct replacement are identified by the colour insert or the colour embossed in words on the base of the plug.

Replacement fuse covers are available from your local electrical store.

### For the Republic of Ireland only

The information given in respect of Great Britain will frequently apply, but a third type of plug and socket is also used, the 2-pin, side earth type.

### Socket outlet / plug (valid for both countries)

If the fitted plug is not suitable for your socket outlet, please contact After-sales Service for further instruction.

Please do not attempt to change plug yourself. This procedure needs to be carried out by a qualified technician in compliance with the manufactures instructions and current standard safety regulations.

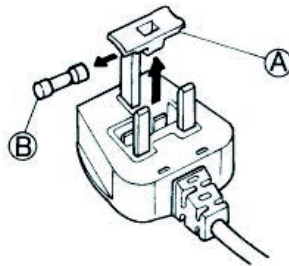

400011234463