

HD Color Video Camera

Operating Instructions

Before operating the unit, please read this manual thoroughly and retain it for future reference.

SRG-360SHE

Table of Contents

Overview

Features	5
How to Use This Operating Instructions ...	6
Camera and Supplied Accessories	6
Location and Functions of Parts and Controls	8
Camera	8
Infrared Remote Commander	10
System Configuration	12
Operating the Camera Via a Network.....	12
Operating a Camera Using the Remote Controller	13
Operating Multiple Cameras Using Multiple Remote Controllers.....	14
Precautions for Preventing Access to the Camera by an Unintended Third Party	15

Installation and Connection

Installing the Camera	16
Installing the Camera on a Desk	16
Attaching the Camera to a Tripod	16
Installing the Camera Using the M3 Fixing Screw Holes.....	16
Installing the unit on the ceiling.....	16
Connections	19
Connecting the power supply	19
Connecting to the PoE+ (Power over Ethernet plus) power supply system.....	20
RS-422 connection with IP remote controller RM-IP10	20
LAN connection with IP remote controller RM-IP10	21
Connecting a Video Monitor, etc., Equipped with HDMI Input Connector.....	21
Connecting with monitors with SDI input connectors	22
Connection with commercially-available microphones etc.	22

Adjusting and Setting with Menus

About On-Screen Menus	23
Main Menu.....	23
Setting Menus.....	23
Control Button Display Section	23
EXPOSURE Menu	24
WHITE BALANCE Menu	25
PICTURE Menu	26
PAN TILT ZOOM Menu	27
SYSTEM Menu	28
STATUS Menu	28

Operation Using the Supplied Infrared Remote Commander

Before Operating	29
Turning on the Power	29
Pan/Tilt and Zoom Operation	30
Panning and Tilting	30
Zooming	31
Operating Multiple Cameras with the Infrared Remote Commander	31
Adjusting the Camera	31
Focusing on a Subject.....	31
Shooting with Back Lighting.....	31
Presetting Feature	32
PTZ TRACE Feature	33
Recording pan/tilt/zoom operations	33
Playing back pan/tilt/zoom operations.....	33
Deleting pan/tilt/zoom operations	33

Operation Using the Remote Controller

Preparation	34
Operating a Camera Using the Remote Controller	35
Operating Multiple Cameras Using Multiple Remote Controllers	35
Pan/Tilt and Zoom Operation	35
Panning and Tilting	35
Zooming	36
Adjusting the Camera	36
Focusing on a Subject.....	36
Shooting with Back Lighting.....	37
Adjusting the White Balance	37
Presetting Feature.....	37
Storing Camera Settings	37
PTZ TRACE Feature	39
Recording pan/tilt/zoom operations.....	39
Playing back pan/tilt/zoom operations.....	39
Deleting pan/tilt/zoom operations	39

Setting with the Remote Controller

About On-Screen Menus	40
Operating with the Remote Controller.....	40
Main Menu.....	40
Setting Menu	40
Control Button Display Section	41
EXPOSURE Menu	41
WHITE BALANCE Menu.....	42
PICTURE Menu	43
PAN TILT ZOOM Menu	44
SYSTEM Menu	45
STATUS Menu.....	45

Operating the Camera Via a Network

Accessing the Camera Using the Web

Browser	46
About Viewers.....	46
Operating the Camera.....	47
Main menu	47
Monitor screen.....	47
Operation panels	48
Pan/Tilt and Zoom Operation	49
Controlling via the control panel	49
Controlling via the preset position panel....	50
Controlling using the monitor screen	50

Setting the Camera Via a Network

Basic Operations of the Administrator

Menu	51
How to set up the Administrator menu	51
Configuration of the Administrator menu	51
System Menu	52
Information Tab.....	52
Installation Tab.....	52
Initialize Tab	53
System log Tab	54
Access log Tab	54
Video Menu	54
Picture Tab.....	54
Video codec Tab.....	56
Superimpose Tab	57
Day/Night ICR Tab.....	57
Audio Menu.....	58
Audio Tab	58
Network Menu.....	59
Network Tab	59
Security Menu.....	61
Administrator and User	61
User Tab	61
Access limit Tab	62
Referer check Tab.....	62
PTZF control Menu.....	63
PTZF control Tab	63
Preset position Tab.....	64
Streaming Menu	65
Streaming Tab	65

Appendix

Message List	67
Troubleshooting	68
Menu Configuration	69
Initial value and preset	71
Specifications	72
Using the VISCA RS-422 connector pin assignments	74

Features

- Supports simultaneous IP image output and HDMI/SDI output.
- Stereo audio (2ch), which is applicable for microphone/line input.
Transfers input audio signal to IP/HDMI/SDI simultaneously.
- The 1/2.8 type Exmor CMOS delivers high-definition shooting with superior picture quality.
- Adopts wide and dynamic range functions. Creates images achieving high visibility, even when bright and dark subjects are incorporated.
- Noise Reduction function delivers clearer images even in low light environment.
- H.264 High Profile video compression mode (video codec) achieves high compression rate while keeping the image quality.
Lessens the network bandwidth load required for image transferring.
- Supports multi-streaming of IP transfer. Up to 3 codec modes can be selected.
- Equipped with smooth, wide-range pan/tilt function and Eflip function. You can install the camera on ceilings.
- Equipped with 30x optical magnification and F1.6 high power and luminous zoom lens that achieves high-quality image.
- Up to 256 camera positions can be preset.
- Equipped with RS-422 interface, industry standard VISCA camera protocol with external connection.
- Capable of PTZ interlocking and recording and replaying the track.
- Pan, Tilt, Zoom, and other camera settings can be set on the menu display.
- Power can be supplied from the AC power adaptor as well as via the network cable (PoE+), making installing easier.

* When power is supplied by PoE+, the available functions will be limited. For details, refer to “Connecting to the PoE+ (Power over Ethernet plus) power supply system” on page 20.

NOTICE TO USERS

© 2014 Sony Corporation. All rights reserved. This manual or the software described herein, in whole or in part, may not be reproduced, translated or reduced to any machine readable form without prior written approval from Sony Corporation.

SONY CORPORATION PROVIDES NO WARRANTY WITH REGARD TO THIS MANUAL, THE SOFTWARE OR OTHER INFORMATION CONTAINED HEREIN AND HEREBY EXPRESSLY DISCLAIMS ANY IMPLIED WARRANTIES OF MERCHANTABILITY OR FITNESS FOR ANY PARTICULAR PURPOSE WITH REGARD TO THIS MANUAL, THE SOFTWARE OR SUCH OTHER INFORMATION. IN NO EVENT SHALL SONY CORPORATION BE LIABLE FOR ANY INCIDENTAL, CONSEQUENTIAL OR SPECIAL DAMAGES, WHETHER BASED ON TORT, CONTRACT, OR OTHERWISE, ARISING OUT OF OR IN CONNECTION WITH THIS MANUAL, THE SOFTWARE OR OTHER INFORMATION CONTAINED HEREIN OR THE USE THEREOF.

Sony Corporation reserves the right to make any modification to this manual or the information contained herein at any time without notice. The software described herein may also be governed by the terms of a separate user license agreement.

- **HD** is trademark of Sony Corporation.
- “Exmor” and *Exmor*[™] are trademarks of Sony Corporation.
- Microsoft, Windows, Internet Explorer and Microsoft DirectX are registered trademarks of Microsoft Corporation in the United States and/or other countries.
- Java Script is a trademark of Sun Microsystems, Inc. in the United States and other countries.
- Intel Core is a registered trademark of Intel Corporation or its subsidiaries in the United States and other countries.
- Adobe, Adobe Reader and Adobe Flash are trademarks of Adobe Systems Incorporated in the United States and/or other countries.
- The terms HDMI and HDMI High-Definition Multimedia Interface, and the HDMI Logo are trademarks or registered trademarks of HDMI Licensing LLC in the United States and other countries.

All other company and product names are trademarks or registered trademarks of the respective companies or their respective makers.

How to Use This Operating Instructions

This Operating Instruction manual describes how to operate the HD Color Video Camera using the infrared remote commander in the package, a PC via a network, or an optional remote controller.

The Operating Instructions is designed to be read on the computer display.

This section gives tips on making the most of the Operating Instructions. Read it before you operate the camera.

Jumping to a related page

When you read the Operating Instructions on the computer display, you can click on a sentence to jump to a related page.

Software display examples

Note that the displays shown in the Operating Instructions are explanatory examples. Some displays may be different from the ones that appear in actual use. The illustrations of the camera and menu display in the Operating Instructions show the SRG-360SHE as an example.

Printing the Operating Instructions

Depending on your system, certain displays or illustrations in the Operating Instructions, when printed out, may differ from those that appear on your screen.

Remote Controller

You can operate and set the camera by using the IP Remote Controller (RM-IP10) (optional accessory). The IP Remote Controller is described simply as “Remote Controller” in this manual.

Camera and Supplied Accessories

When you unpack, check that all the supplied accessories are included.

Camera (1)

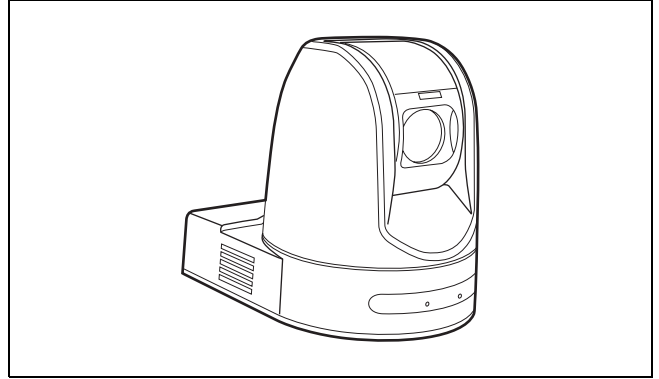

AC power adaptor (MPA-AC1) (1)

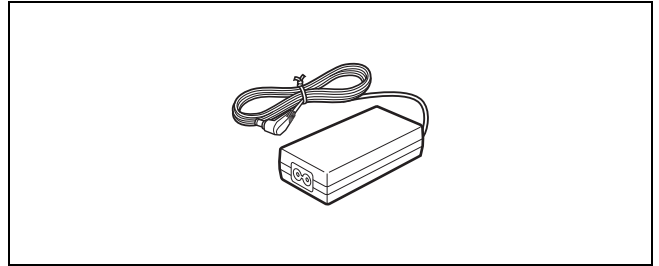

AC power cord (1)

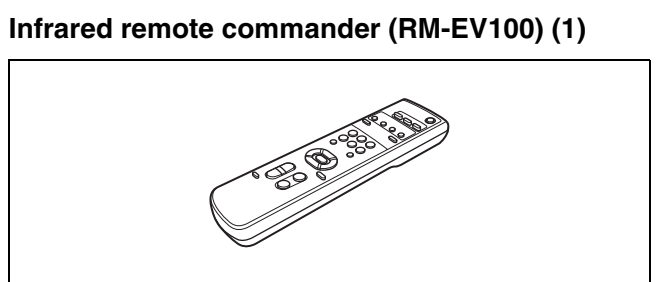

AC power cord (1)

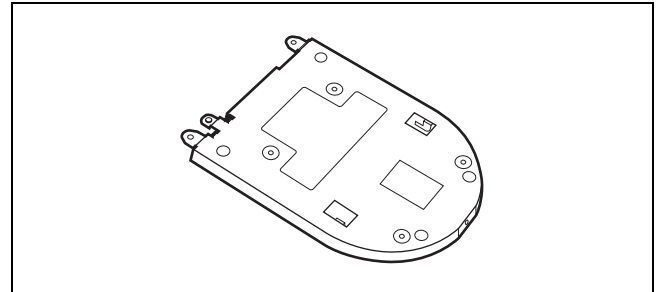

Ceiling bracket (B) (1)

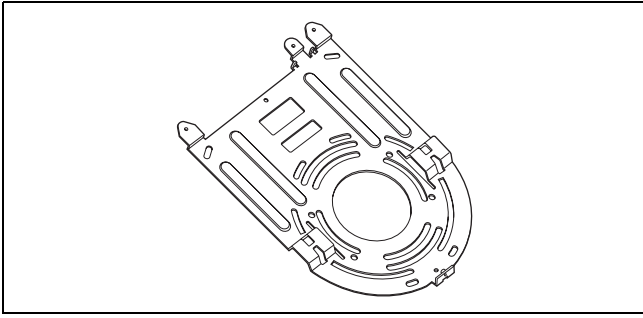

Wire rope (1)

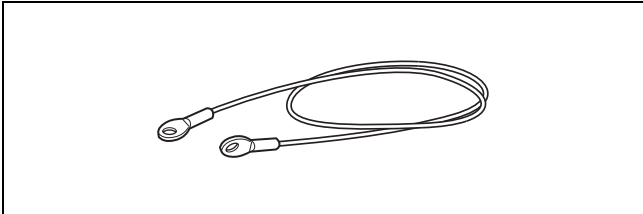

Screw +M3 × 8 (9)

Screw +M2.6 × 6 black (1)

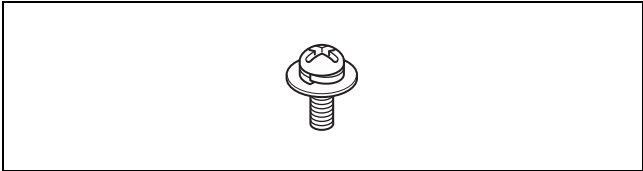

HDMI cable fixing plate (1)

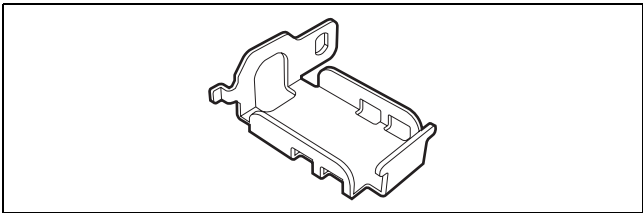

Operating Instructions - Download site Information (1)

Safety Regulations (1)

Warranty (1)

Optional Products

RM-IP10 IP Remote Controller

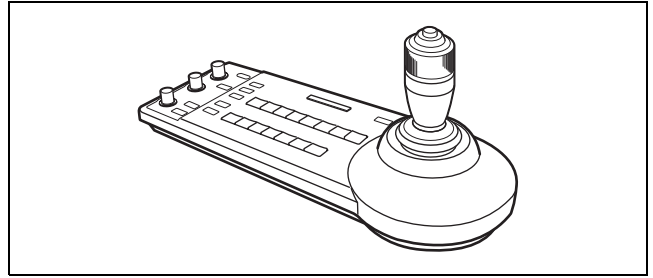

Operate up to 112 cameras that are compatible with an IP connection. Up to five RM-IP10 IP remote controllers can be installed to the same system.

The joystick of the IP remote controller offers comfortable pan/tilt and zoom operations. Up to seven cameras can be operated via the RS-232 connection or RS-422 connection. However, for SRG-360SHE, only one camera can be operated via the RS-422 connection.

Location and Functions of Parts and Controls

Camera

Front

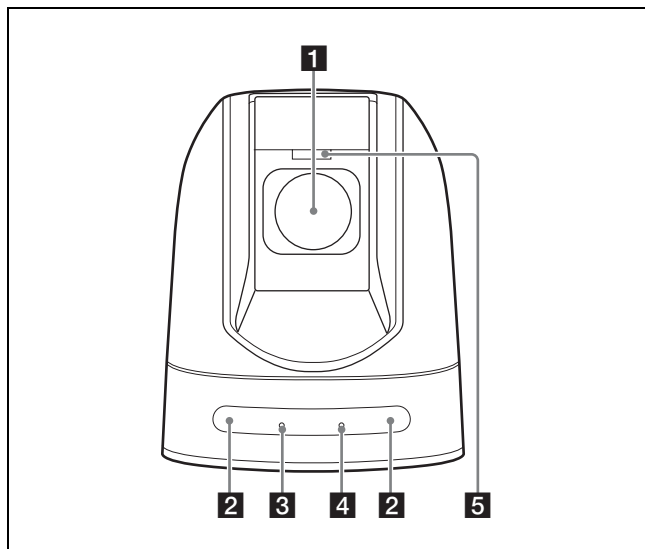

1 Lens

This is a 30-magnification optical zoom lens.

2 Infrared remote commander sensors

These are sensors for the supplied infrared remote commander.

3 POWER lamp

The green light turns on when the camera is connected to an AC outlet using the supplied AC power adaptor and AC power cable, or when power is supplied via the LAN connector with PoE+.

4 NETWORK lamp

The green light will turn on when the preparation for network connection is done and all movements are available.

5 TALLY lamp

The status of video shooting can be indicated by the lamp.

Rear

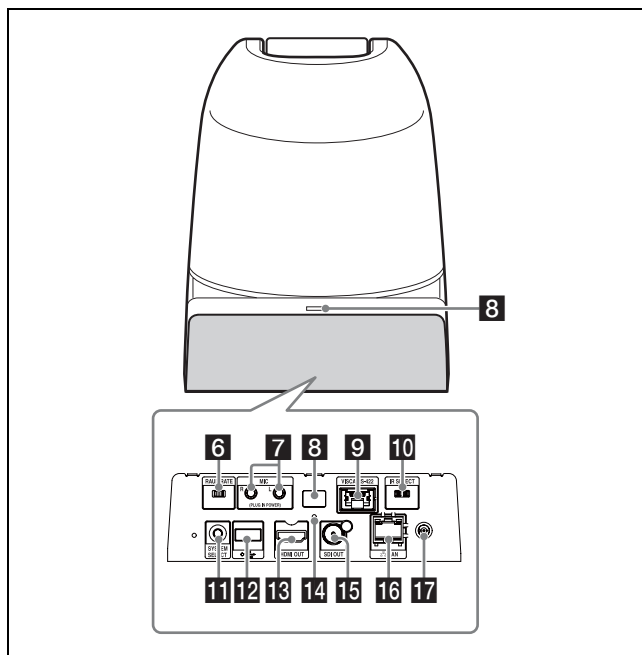

6 BAUD RATE switch

Used to switch between 9,600bps and 38,400bps for the RS-422 baud rate.

7 MIC input

Input for commercially-available MIC or LINE to connect an Audio device.

* Switch between MIC and LINE input, as indicated on page 22.

8 Infrared remote commander sensors

These are sensors for the supplied infrared remote commander.

9 VISCA RS-422 connector (RJ-45 8-pin)

To communicate via RS-422, use this connector. For the connecting cables, see “RS-422 connection with IP remote controller RM-IP10” (page 20).

10 IR SELECT switch

Select the camera number when you operate multiple cameras with the same infrared remote commander.

11 SYSTEM SELECT switch

Used to set method to output image signal, which is output via HDMI and SDI OUT video connector. For details, see “Setting of the SYSTEM SELECT switch” (page 9).

12 USB connector

This is not available to use. It is for maintenance purposes.

13 HDMI OUT video connector

Outputs the image from the camera as an HDMI video signal.

14 Screw hole for HDMI cable fixing plate

Mount the supplied “HDMI cable fixing plate”.

15 SDI OUT connector

Outputs video from this product as an HD SDI (3G-HD SDI compatible) video signal.

16 LAN connector (RJ-45 8-pin)

Network communication and PoE+* power supply are performed by using the network cable (category 5e or higher, shielded twist pair).

For more information on the connection, refer to the Operating Instructions included with power supply system.

(*PoE+: an abbreviation of Power over Ethernet Plus, which complies with IEEE802.3at)

The green indicator lights when the link is established.

The orange indicator will blink during communication.

17 DC 12 V connector

Connect the supplied AC power adaptor.

Bottom

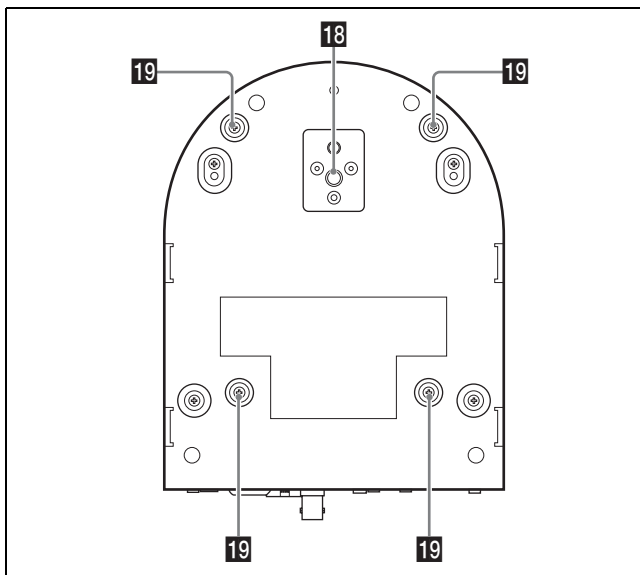

18 Tripod screw hole

Screw hole to mount tripod.

For details, refer to “Attaching the Camera to a Tripod” (page 16).

19 Ceiling bracket mounting screw holes

Screw hole to mount the supplied ceiling bracket (A) when you mount the camera on the ceiling.

For details, refer to “Installing the Camera” (page 16).

Setting of the SYSTEM SELECT switch

This switch allows you to select the video format of the signal to be output from the HDMI OUT/SDI OUT connectors.

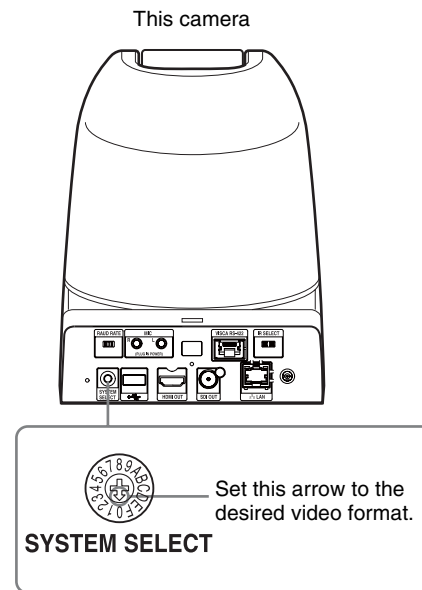

Switch position	Video format	
0	1920×1080p/59.94 (A)	59.94 Hz system
1	1920×1080p/59.94 (B)	
2	1920×1080p/29.97	
3	1920×1080i/59.94	
4	1280×720p/59.94	
5	1280×720p/29.97	
6	1920×1080p/59.94 (A)	
7	WEB UI	–
8	1920×1080p/50 (A)	50 Hz system
9	1920×1080p/50 (B)	
A	1920×1080p/25	
B	1920×1080i/50	
C	1280×720p/50	
D	1280×720p/25	
E	1920×1080p/59.94 (A)	59.94 Hz system
F	No output	–

Notes

- Configure the setting of the switch before turning the camera on.
Turn on the power supply after setting the switch.
- Always use a cross slot screwdriver to toggle the switch. Otherwise, the cross chase might be stripped.
- When the switch is positioned as 7 (WEB UI), the video format can be set via the external connection.

For details, refer to “Installation Tab” on page 52.

Infrared Remote Commander

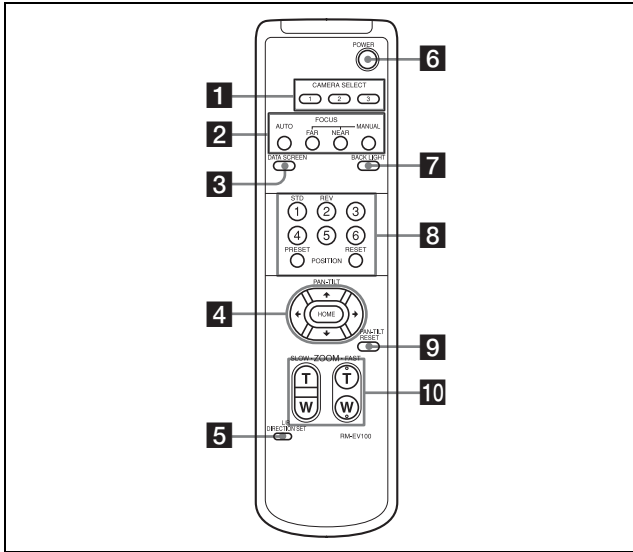

1 CAMERA SELECT buttons

Press the button corresponding to the camera you want to operate with the infrared remote commander. The camera number can be set using the IR SELECT switch on the rear of the camera.

Note

If two or more cameras are adjacent and have the same camera number, they are operated simultaneously with the same infrared remote commander. When you install the cameras close to each other, set different camera numbers.

For the camera number setting, see “Operating Multiple Cameras with the Infrared Remote Commander” (page 31).

2 FOCUS buttons

Used for focus adjustment.

Press the AUTO button to adjust the focus automatically. To adjust the focus manually, press the MANUAL button, and adjust it with the FAR and NEAR buttons.

Note

Press the MANUAL button and adjust the focus manually when shooting the following objects.

- White walls and other objects without contrast
- Objects behind glass
- Objects with horizontal stripes
- Objects on which bright lights are cast or reflected
- Nightscapes and other dark objects with blinking lights
- Lit objects shot with darkened exposure adjustment or exposure compensation settings

3 DATA SCREEN button

Press this button to display the main menu. Press it again to turn off the menu. If you press the button when a lower-level menu is selected, the display goes back to a higher-level menu.

Note

The pan/tilt operation will be disabled when MENU is displayed (except: PAN/TILT LIMIT or PTZ TRACE settings).

4 PAN-TILT buttons

Press the arrow buttons to adjust the direction of the camera. Press the HOME button to face the camera back to the front.

When the menu is displayed, use \uparrow or \downarrow to select the menu items and \leftarrow or \rightarrow to change the set values. The selected setting menu is displayed, by pressing the HOME button when the main menu is displayed. You can change the menu position with either the \leftarrow or \rightarrow button.

5 L/R DIRECTION SET button

Hold down this button and press the REV button to change the direction of the camera movement opposite to that indicated by the arrow of the \leftarrow/\rightarrow buttons.

To reset the direction of the camera movement, press the STD button while holding down this button.

6 POWER button

Turns on/off the camera output video.

7 BACK LIGHT button

Press this button to enable the backlight compensation. Press it again to disable the backlight compensation.

8 POSITION buttons

Hold down the PRESET button and press button 1 to 6 to store the current camera direction, zooming, focus adjustment and backlight compensation in the memory of the pressed number button.

To erase the memory contents, hold down the RESET button and press button 1 to 6.

Note

These buttons do not function when the menu is displayed.

9 PAN-TILT RESET button

Press this button to reset the pan/tilt position.

10 ZOOM buttons

Use the SLOW button to zoom slowly, and the FAST button to zoom quickly.

Press the T (telephoto) side of the button to zoom in, and the W (wide angle) side to zoom out.

To install batteries

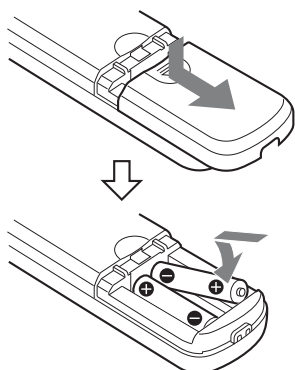

Two R6 (size AA) batteries
(not supplied)

CAUTION

Danger of explosion if battery is incorrectly replaced.
Replace only with the same or equivalent type
recommended by the manufacturer.
When you dispose of the battery, you must obey the law
in the relative area or country.

Installing batteries

Two R6 (size AA) batteries are supplied for Infrared
Remote Commander.
To avoid risk of explosion, use R6 (size AA) manganese
or alkaline batteries.

System Configuration

This camera has various system configuration capabilities using optional products. This section describes typical system examples with the required components and the main usage of each system.

Operating the Camera Via a Network

What you can do with this system

Multiple users can view video and audio from one camera via a network at the same time.

System Configuration

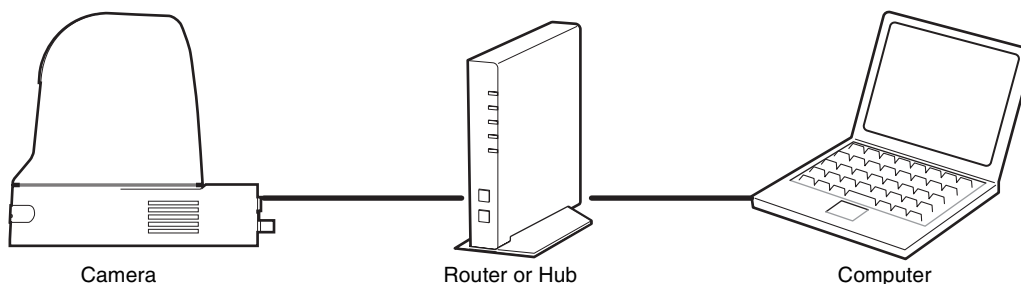

For details concerning operation and the setting of the camera via a network, see “Operating the Camera Via a Network” on page 46 or “Setting the Camera Via a Network” on page 51.

Notes

- **Factory settings for IP**
IP address: 192.168.0.100
Subnet mask: 255.255.255.0
- The maximum number of users that can view changes depending on the video and audio settings.
- If the simultaneous connections via a network increase, the frame rate may decrease.

Operating Environment Requirements

The following operating environment is necessary for the computer to display images and the controls of the camera. (July 2016)

OS

Windows 7 (32bit version, 64-bit version), Windows 8.1 Pro (32bit version, 64-bit version)*¹, Windows 10 Pro (32bit version, 64-bit version) *²

Authorized editions:

Windows 7: Ultimate, Professional

Windows 8.1: Pro

Windows 10: Pro

Web Browser

Windows Internet Explorer Ver. 11.0*¹

Google Chrome Ver.50.0

CPU

Intel Core i7, 2.8 GHz or higher

Or Intel Core i3 / Intel Core i5 / Intel Core i7 (with built-in Intel HD Graphics)

Memory

2 GB or more

Display

1600 × 1200 pixels or higher

*1 If you use Windows 8.1, use the Internet Explorer for the desktop user interface (desktop UI).

*2 If you use Windows 10, turn off the tablet mode.

Operating a Camera Using the Remote Controller

What you can do with this system

To perform pan/tilt and zoom operations using the joystick of the remote controller, and to perform the Preset operation using the button.

System Configuration

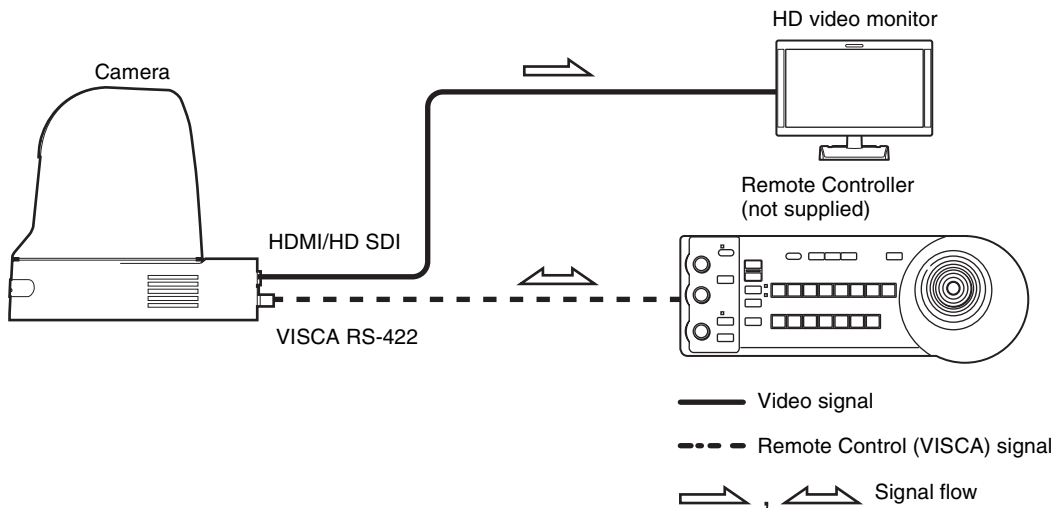

Notes

- Only RS-422 connection is available for VISCA CONTROL.
- The communication speed should be adjusted with the BAUD RATE switch on the back of the unit and the remote controller.
- To change the video format, you should choose the one you want using the SYSTEM SELECT switch or on the browser window via a network.
 - * Settings cannot be changed via the menu displayed on HDMI OUT/SDI OUT.

For details concerning operation and the setting of the camera using the remote controller, see “Operation Using the Remote Controller” on page 34 or “Setting with the Remote Controller” on page 40.

Operating Multiple Cameras Using Multiple Remote Controllers

What you can do with this system

- You can connect up to 112 cameras and five remote controllers.
- The joystick of the remote controller allows comfortable pan/tilt and zoom operations.

System Configuration

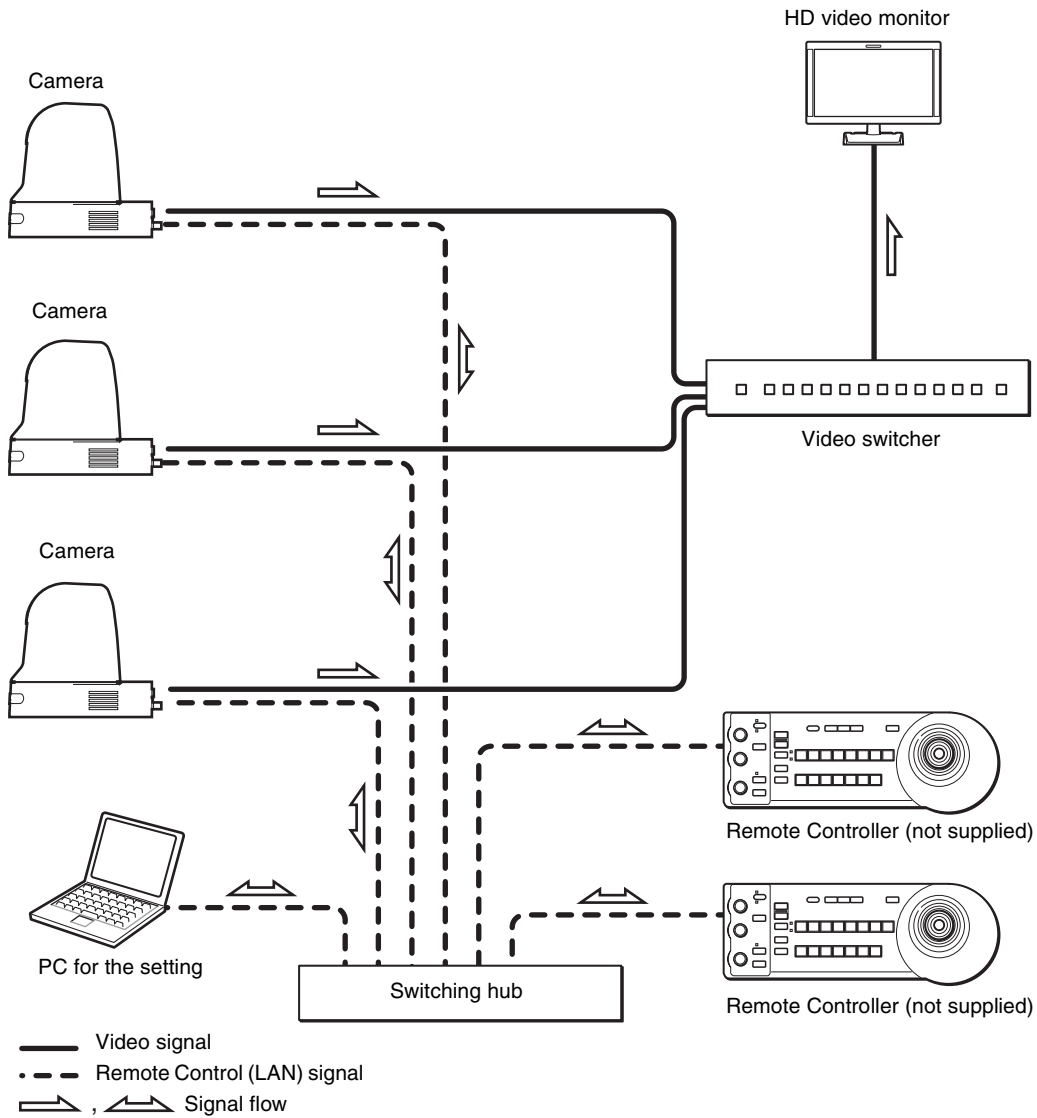

Note

When you control the camera by using the LAN connection, use a shielded twisted pair network cable that is category 5e or higher.

Precautions for Preventing Access to the Camera by an Unintended Third Party

The camera may be accessed by an unintended third party on the network, depending on the usage environment. Changing the user name and password of the camera administrator from the default settings is highly recommended for security reasons. If the camera is accessed by an unintended third party, there may be undesired effects such as operations or settings that may interfere with viewing.

Also, this camera's RTSP stream is not encrypted. Use the camera in a safe network.

The camera can be fraudulently accessed in a network environment where a device is connected or connectable to the network without the administrator's permission, or a PC or other network device connected to the network can be used without any permission. Connect to these environments at your own risk.

Do not use the browser you use to set the camera to access other websites while you set or after setting the camera. You will remain logged in to the camera as long as the browser is open, so to prevent an unintended third party's use or execution of malicious programs, close the browser after you finish setting the camera.

Installation and Connection

Installing the Camera

Installing the Camera on a Desk

Place the camera on a flat surface.

If you have to place the camera on an inclined surface, make sure that the inclination is less than ± 15 degrees to guarantee pan/tilt performance, and take measures to prevent it from falling.

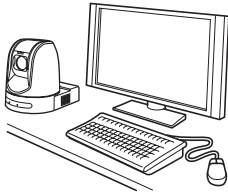

Notes

- Do not grasp the camera head when carrying the camera.
- Do not turn the camera head by hand. Doing so may result in a camera malfunction.

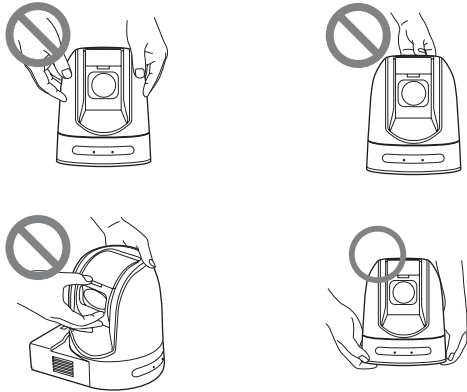

Attaching the Camera to a Tripod

Attach a tripod to the screw hole used for attaching a tripod on the bottom of the camera.

The tripod must be set up on a flat surface and its screws tightened firmly by hand.

Use a tripod with screws of the following specifications.

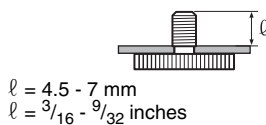

Caution

Installation of the camera using the tripod screws and screw holes should not be done for installation on a ceiling or a shelf, etc., in a high position.

Installing the Camera Using the M3 Fixing Screw Holes

Attach the camera using 4 M3 fixing screw holes located on the bottom of the camera.

Attach the camera to a fitting with a flat surface using M3 screws with the following specifications.

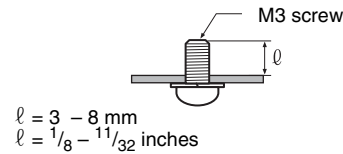

Installing the unit on the ceiling

Using the ceiling bracket, wire rope, and screws supplied, you can attach the camera to the ceiling.

When you install the unit, always install it on a level ceiling. If you have to install it on a sloping or uneven ceiling, make sure that the place where you install it is within ± 15 degrees of the horizontal.

CAUTION

- Entrust installation to an experienced contractor or installer when installing the unit on ceilings or other high locations.
- When installing the unit in a high location, be sure that the location and installation components (excluding the supplied accessories) are strong enough to support the unit and the mounting bracket, and install the unit securely. If the components are not strong enough, the unit may fall and cause serious injury.
- Always install the supplied wire rope to prevent the unit from falling.
- If you install the unit in a high location, check periodically, at least once a year, to ensure that the connection has not loosened. If conditions warrant, make this periodic check more frequently.

Before installation

Determine the shooting direction of the camera, and then make the holes for the ceiling bracket (B) and the connecting cables on the ceiling.

Notes

- The connecting cables cannot be passed through ceiling bracket (B). A hole for the wiring is required in the ceiling at the back of the unit where it is attached to the ceiling.
- The recommended tightening torque for each screw are described in below.
M3: 0.6 N·m (6.1 kgf·cm)
M2.6: 0.4 N·m (4.1 kgf·cm)

Installation

- 1 Attach the wire rope to the ceiling.

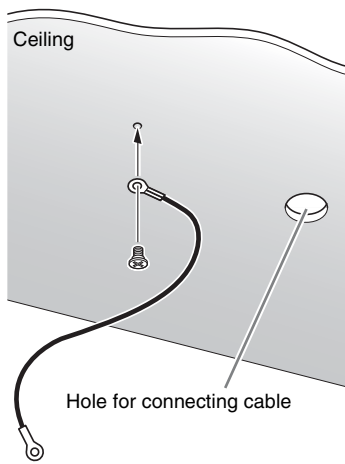

- 1-2 In the case that a wire cannot be attached on the ceiling, attach the wire on the ceiling bracket (B) as illustrated below with the supplied screws (M 3 × 8).

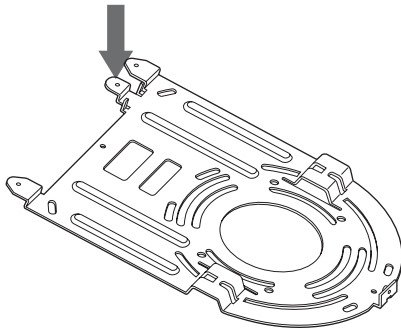

- 2 Attach the ceiling bracket (B) to the ceiling. When attaching the ceiling bracket (B) to the ceiling, it is recommended to fix at the 4 positions illustrated below.

There are elongated holes for the screws along the rounded edges of the ceiling bracket (B). Later, the front of the camera will be positioned along this edge. Face the camera to the front, adjust the aim, and attach it securely.

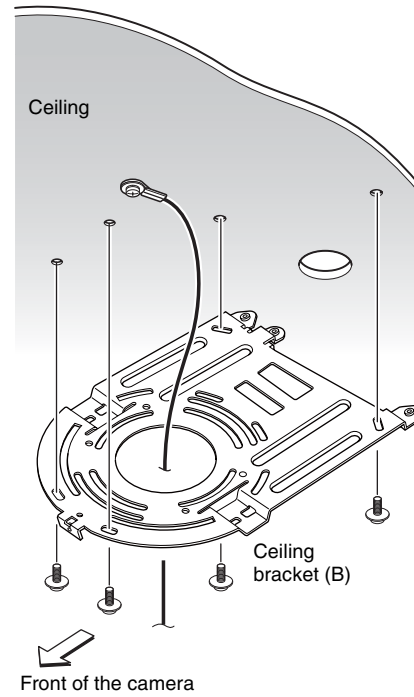

- 3** Attach the ceiling bracket (A) to the bottom of the camera using the 4 screws (M 3 × 8) supplied. Align the bracket holes with the screw holes on the camera, and attach the bracket to the camera.

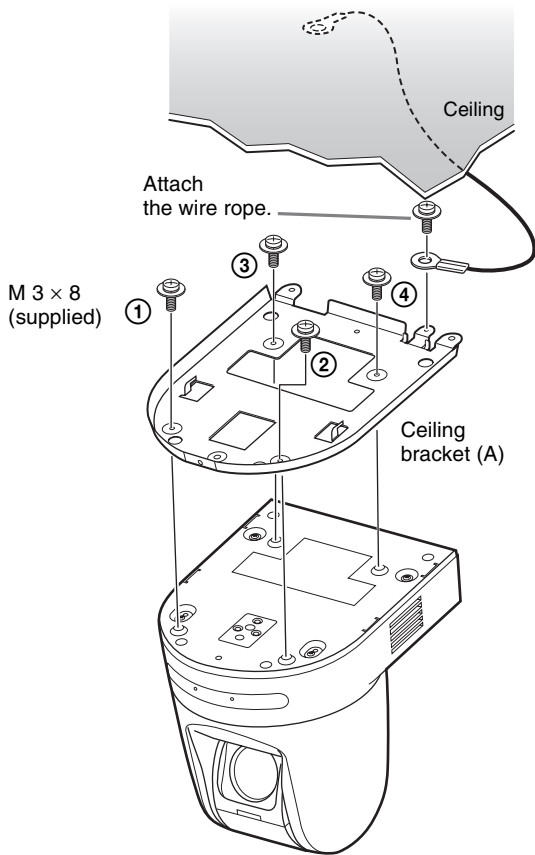

Tighten the screws a bit at a time in the numbered order shown in the illustration. After all of the screws are inserted and temporarily tightened properly, securely tighten each one in turn.

Note

For assembly, use only the screws supplied with the unit. Using other screws may damage the unit.

- 4** Insert the protrusions raised on the ceiling bracket (A) into the spaces prepared in the ceiling bracket (B), and temporarily attach them by pushing the ceiling bracket (A) to the rear.

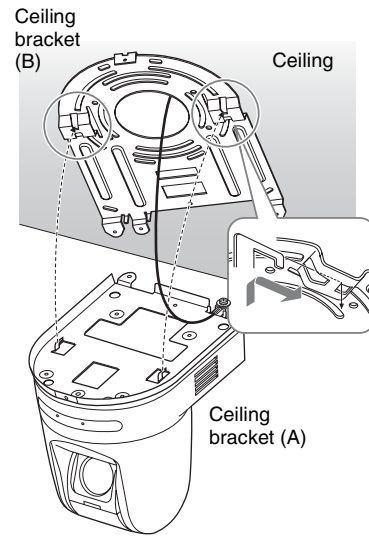

- 5** While pushing up on the front part of the camera, attach it using the 3 screws (M 3 × 8) supplied, starting with the screw at position ①.

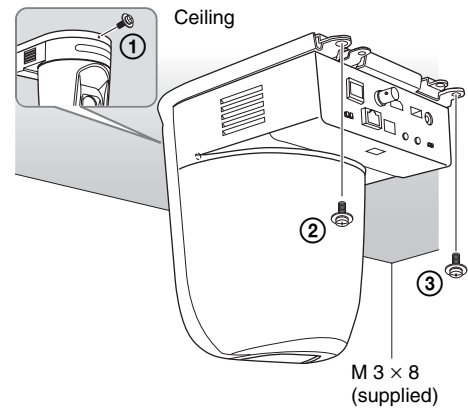

Lightly tighten screws temporarily in the order indicated in the figure. Afterwards, screw each of them firmly.

- 6-1** Connect the cables to the connectors on the rear of the camera.

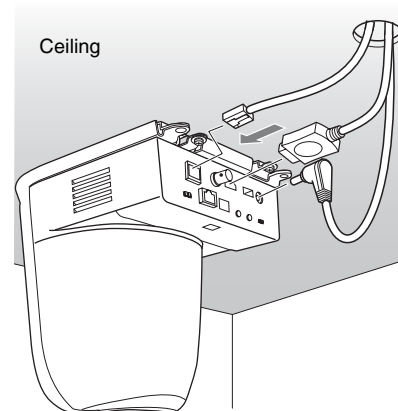

Notes

- Take the proper steps to ensure that the load of the cables connected does not cause problems.
- To prevent cables from coming off, it is recommended to proceed to 6-2 after connecting the HDMI cable, and then connect other cables.

6-2 To prevent the HDMI cable from coming off, mount the HDMI cable fixing plate with the supplied screw (single, M2.6 × 6, black) on the rear side of the camera, then fix the HDMI cable with a banding band etc.

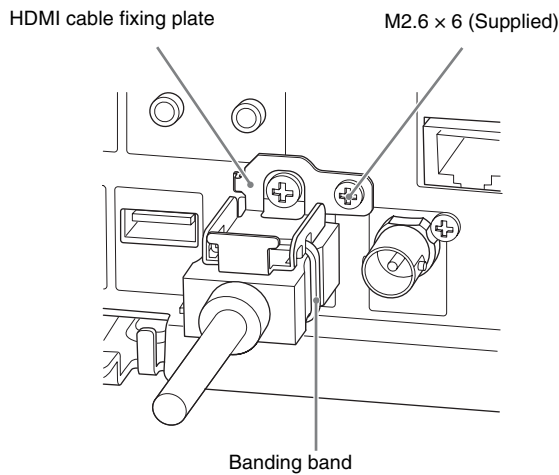

Note

Do not attach the HDMI cable on the camera unit, if you do not use them.

7 Adjust the Eflip function to optimize the ceiling mounting status via the Web browser or menu display.

Note

All preset settings will return to their default when adjusting the setting of the Eflip function. When setting, make sure to set the Eflip function before the preset settings.

Removing the camera

- 1** Remove the 3 screws used to attach the camera in step 5 of “Installation.”
- 2** While pushing the entire camera up towards the ceiling, move the camera to the front. The hooks will disengage, and you can remove the camera.

Connections

Connecting the power supply

Power is supplied to the unit using the following methods.

- Supplied AC power adaptor
- PoE+* (power supply system, which complies with IEEE802.3at)

* PoE+: an abbreviation of Power over Ethernet plus.

Power supply with the supplied AC power adaptor

Use the supplied AC power adaptor and AC power cord to connect the camera to an AC outlet.

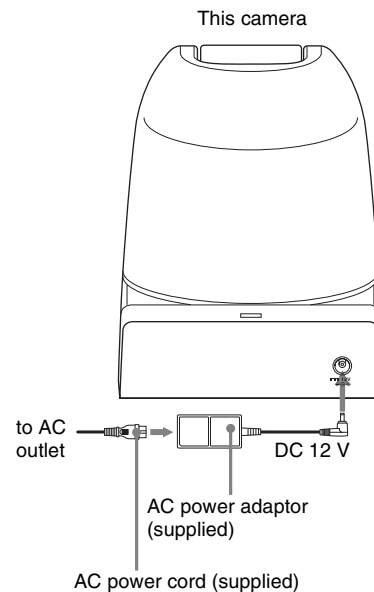

CAUTION

- This product is not equipped with a power switch. When installing this product, install dedicated cutoff equipment within the fixed wiring that can be easily accessed or connect the power plug to an outlet near the camera where it can be easily inserted/removed. If an abnormality occurs, apply the cutoff equipment or remove the power plug.
- When supplying power using the AC power adaptor, do not connect the PoE+ power supply system.
- Wait approximately 10 seconds before turning the power on again.

Connecting to the PoE+ (Power over Ethernet plus) power supply system

PoE+ (complied with IEEE802.3at) power supply equipment supplies power via a commercially-available network cable. For details, refer to the instruction manual of your power supply device.

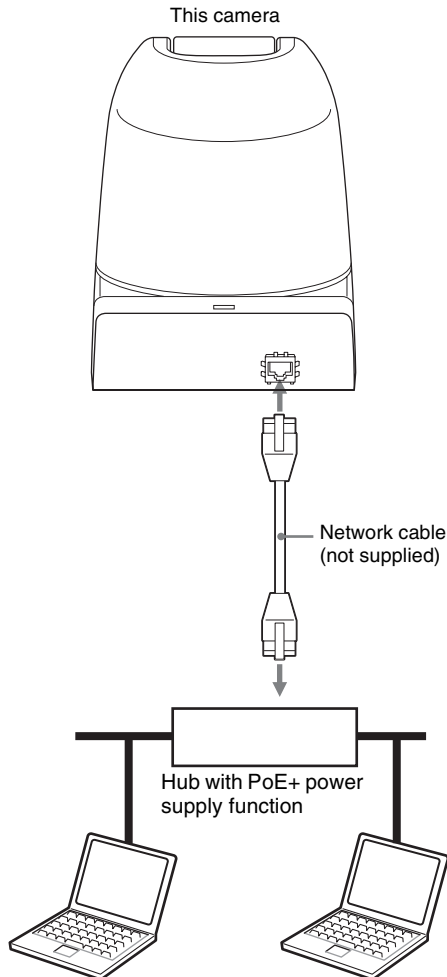

Notes

- To supply power via PoE+, use a shielded twisted pair network cable of category 5e or higher. Do not connect the AC power adapter, when supplying power via PoE+.
- When power is supplied via PoE+, the POWER light does not turn on until the initial authentication is completed (the time varies depending on the model; it is approximately one minute).
- HDMI video output and the video outputs 2 and 3 via a network become disabled when power is supplied via PoE+.
- Wait approximately 10 seconds before turning the power on again.
- The HD Color Video Camera is to be connected only to PoE+ networks without routing to the outside plant.

RS-422 connection with IP remote controller RM-IP10

Connect to the IP remote controller using the connection cable.

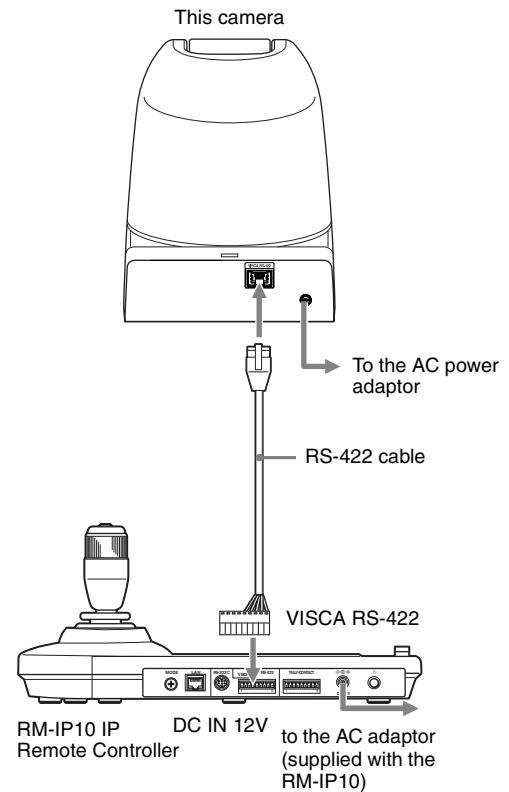

Note

To connect using the VISCA RS-422 connector, create the connection cable using the RS-422 connector block which is supplied with the camera and IP remote controller.

For making the cable, refer to “Using the VISCA RS-422 connector pin assignments” on page 74.

LAN connection with IP remote controller RM-IP10

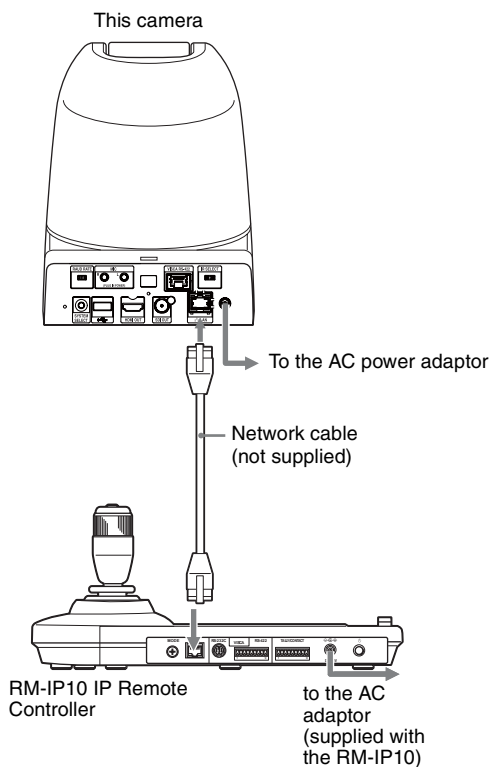

Notes

- Use the network cable of category 5e or higher, shield twist pair.
- Use the crossover cable if you want to connect directly to the LAN connector of one camera and one IP remote controller without using a switching hub.

Connecting a Video Monitor, etc., Equipped with HDMI Input Connector

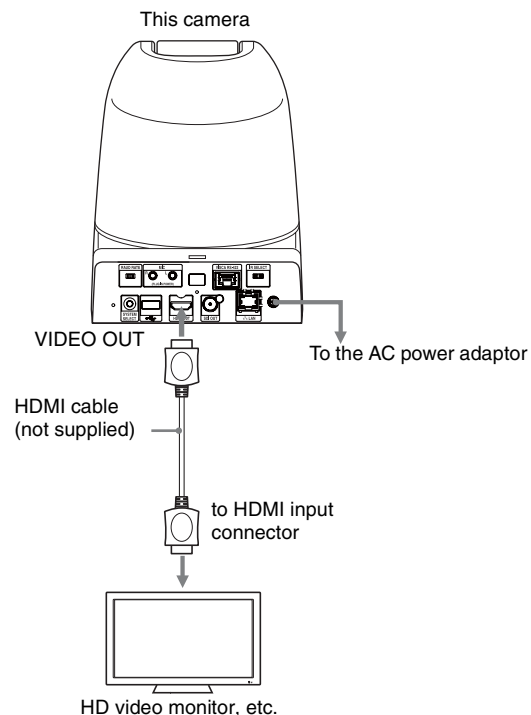

Notes

- Configure the VIDEO FORMAT, based on the specifications of the HD monitor.
- Depending on the performance capabilities of the HDMI cable, some picture noise may occur. It is recommended to use a Sony high-speed HDMI cable.
- If the volume of the monitor is set to maximum, a sound may emit for a moment when activated, depending on the product. This is not a malfunction.
- It takes approximately 40 seconds for the video to come out.
- When installing, use attached fixing parts in order to prevent HDMI cables from removing due to the cable's weight or external force.
- This becomes disabled when power is supplied via PoE+.

Connecting with monitors with SDI input connectors

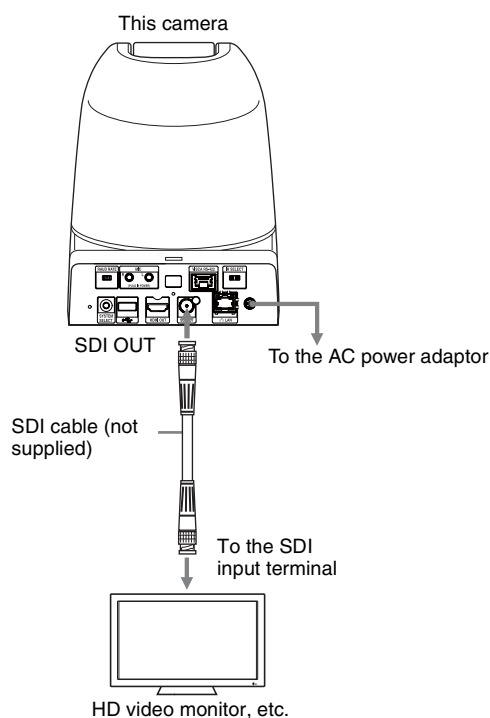

Notes

- Set VIDEO FORMAT based on the specifications of the HD monitor.
- Depending on the performance of the HD SDI cable, some noise can occur on the image. We recommend to use a 5C-FB cable that meets the HD SDI rating.
- When the volume of the monitor is set to the maximum, a sound can be heard for a moment on launching on some devices. This is not a malfunction.
- It takes approximately 40 seconds for the video to come out.
- When power is supplied via PoE+, it takes approximately 90 seconds depending on the PoE+ device.

Connection with commercially-available microphones etc.

Connect a commercially-available microphone, mixer, etc.

Input audio will be superimposed to the HDMI OUT/SDI OUT/IP video output via stereo.

Switch between the microphone input and line input by selecting either input on the web browser.

Connect a commercially-available microphone when using the microphone input.

Connect a commercially-available mixer when using the line input.

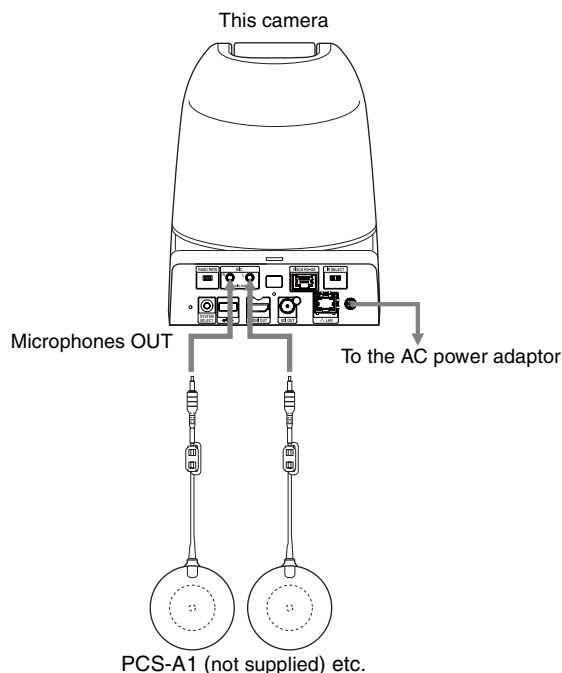

Notes

- Do not place the camera near devices that may generate noise.
- If you place a microphone near this camera, it may pick up the sound from the camera. Check the audio of the microphone input in advance when installing.
- When microphone input is selected, the unit supplies 2.5 VDC Plug-in-power. Do not connect a non-supported microphone when the microphone input is selected.

Adjusting and Setting with Menus

About On-Screen Menus

You can change various settings, such as shooting conditions and system setup of the camera, while observing menus displayed on a connected computer screen.

This section explains how to read the on-screen menus before starting menu operations.

For the overall menu configurations, see “Menu Configuration” (page 69).

Note

You cannot perform pan/tilt operations while the menu is displayed.

This menu will be shown only for HDMI OUT/SDI OUT.

Main Menu

To display the main menu, press the DATA SCREEN button on the supplied infrared remote commander.

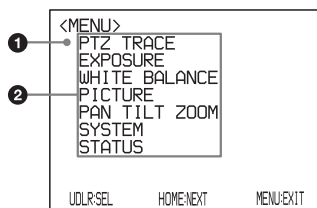

1 Selected item

Selects a setting menu.

The currently selected item is shown in red.

The selected item shifts up or down when you press the \uparrow or \downarrow button on the infrared remote commander.

2 Menu items

To display a setting menu, select one using the \uparrow or \downarrow button on the infrared remote commander and press the HOME button on the infrared remote commander. The menu display position changes when you press the \rightarrow or \leftarrow button in the main menu.

Setting Menus

The setting menu selected on the main menu is displayed.

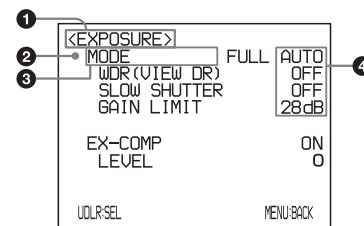

1 Setting menu

The name of the setting menu currently selected is displayed here.

2 Selected item

Selects a setting item.

The currently selected item is shown in red.

The selected item shifts up or down when you press the \uparrow or \downarrow button on the infrared remote commander.

3 Setting items

The setting items for this setting menu are displayed.

Select the setting item using the \uparrow or \downarrow button on the infrared remote commander.

4 Set value

The currently set values are displayed.

To change a set value, use the \leftarrow or \rightarrow button on the infrared remote commander.

For the default value of each setting item, see “Menu Configuration” (page 69).

Control Button Display Section

Names of buttons displayed on the monitor are different from buttons on the infrared remote commander to be used.

Use the proper buttons on the infrared remote commander, referring to the following pictures.

Main menu

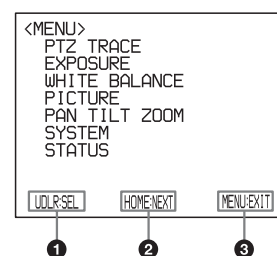

- ❶ Indicates that you can select a menu item by \uparrow or \downarrow button on the infrared remote commander. The selected item is shown in red.
- ❷ Indicates that you can move to the next layer by pressing the HOME button.
- ❸ Indicates that you can return to the normal display by pressing the DATA SCREEN button.

Setting menu

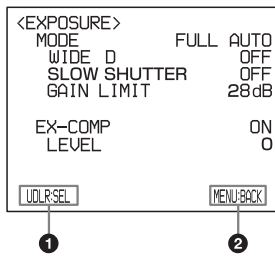

- ❶ Indicates that you can select the setting item by using the \uparrow or \downarrow button and you can change the set value by using the \leftarrow or \rightarrow button.
- ❷ Indicates that you can return to the main menu by pressing the DATA SCREEN button.

Note

For detailed information on how to connect and VISCA command list, refer to the Technical Manual of the camera. For details on obtaining a Technical Manual, consult your Sony dealer.

EXPOSURE Menu

The EXPOSURE menu is used to set the items related to the exposure.

This can be set via the Web browser. See “Exposure” (page 54).

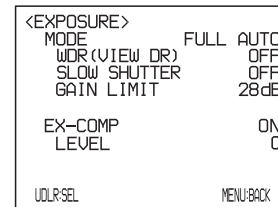

MODE (exposure mode)

FULL AUTO: The exposure is adjusted automatically using the sensitivity, electronic shutter speed, and iris.

BRIGHT: Adjust the brightness level (LEVEL) manually.

SHUTTER PRI: Shutter Priority mode. The exposure is adjusted automatically using the sensitivity and iris. Adjust the electronic shutter speed (SPEED) manually.

IRIS PRI: Iris Priority mode. The exposure is adjusted automatically using the sensitivity and electronic shutter speed. Adjust the iris (IRIS) manually.

MANUAL: Adjust the sensitivity (GAIN), electronic shutter speed (SPEED) and iris (IRIS) manually.

When you select one from among the various exposure modes, some of the following setting items that are required for the selected mode appear.

GAIN: Select the gain from among the following:

0, 3, 6, 9, 12, 15, 18, 21, 24, 27, 30, 33, 36, 39, 43 dB

SPEED: Select the electronic shutter speed from among the following:

For the 59.94/29.97 video format:

1/1, 1/2, 1/4, 1/8, 1/15, 1/30,
1/60, 1/90, 1/100, 1/125, 1/180, 1/250,
1/350, 1/500, 1/725, 1/1000, 1/1500,
1/2000, 1/3000, 1/4000, 1/6000,
1/10000 sec.

For the 50/25 video format:

1/1, 1/2, 1/3, 1/6, 1/12, 1/25,
1/50, 1/75, 1/100, 1/120, 1/150, 1/215,
1/300, 1/425, 1/600, 1/1000, 1/1250,
1/1750, 1/2500, 1/3500, 1/6000,
1/10000 sec.

IRIS: Select the iris from among the following:

CLOSE, F14, F11, F9.6, F8.0, F6.8, F5.6, F4.8, F4.0,
F3.4, F2.8, F2.4, F2.0, F1.6

LEVEL: Select the brightness level.

Select the brightness level from among 0, 5 to 31.

WDR (VIEW-DR): When MODE (exposure mode) is set to FULL AUTO, the camera distinguishes light and dark areas in the same scene, adjusts the brightness for dark areas, and also controls the blown out highlights.

You can select the wide dynamic range mode from among OFF, LOW, MID and HIGH.

Notes

- You can set the wide dynamic range mode when WDR (VIEW-DR) is set to FULL AUTO only.
- When changing WDR (VIEW-DR), a change in screen luminance occurs for a moment.
- When the change of exposure is big, the screen may stop for a moment.
- The audio will be muted for approximately 1 second when WDR (VIEW-DR) switches.

GAIN LIMIT: Select the upper limit of the gain rise in FULL AUTO, SHUTTER PRI and IRIS PRI modes. Select from among 9, 12, 15, 18, 21, 24, 27, 30, 33, 36, 39, 43 dB.

EX-COMP (exposure compensation)

When MODE is set to one of FULL AUTO, SHUTTER PRI or IRIS PRI, set this item to ON to enable exposure compensation. When you set EX-COMP to ON, LEVEL appears and you can select the exposure compensation level from among the following:

-7, -6, -5, -4, -3, -2, -1, 0, 1, 2, 3, 4, 5, 6, 7

If you set the level to 0, exposure compensation will be disabled. Level 7 is the brightest and -7 is the darkest compensation value.

When EX-COMP is set to OFF, exposure compensation does not function.

SLOW SHUTTER

When you set the mode to ON, the camera automatically uses slow shutter speed for exposure as the illumination of the object to be shot decreases. This mode is only available when AE mode is set to FULL AUTO.

WHITE BALANCE Menu

The WHITE BALANCE menu is used to select the white balance mode.

This can be set via the Web browser.

See “White balance” (page 55).

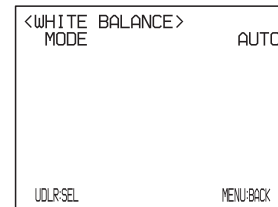

MODE (white balance mode)

Select the white balance mode from among the following: AUTO, IN DOOR, OUT DOOR, ONE PUSH, ATW (Auto Tracing White Balance), MANUAL.

When you select MANUAL, R.GAIN (R gain), B.GAIN (B gain) will be displayed. These can be adjusted within the range between 0 and 255.

When you select the ONE PUSH mode

Perform the following while the white balance menu is displayed.

- 1 Zoom in on a white subject in the center of the screen.
- 2 Press the HOME button of the supplied infrared remote commander.
The one-push white balance adjustment is activated.

PICTURE Menu

The PICTURE menu is used to set the items related to the picture.

See “Picture” (page 56) or “Installation Tab” (page 52).

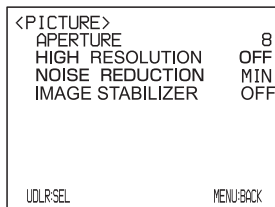

APERTURE (aperture compensation)

Select the aperture compensation level from among MIN, 1 to 14 and MAX.

HIGH RESOLUTION (high resolution mode)

You can set this mode to ON or OFF. When set to ON, you can enjoy emphasised edge and high-resolution images.

Note

When this is turned on, the image will have more noise than when shooting with it turned off.

NOISE REDUCTION (noise reduction)

You can enjoy clearer images by removing unnecessary noise (fixed pattern and randomised noise). You can select 6 levels from OFF (MIN), 1 to 5 (MAX).

IMAGE STABILIZER (image stabilizer)

You can select this function according to the shooting conditions.

OFF: The image stabilization feature becomes disabled.

ON: The image stabilization feature becomes enabled.

When set to ON, you can obtain steadier images if vibration is present. This stabilizer is effective for vibration frequencies around 10 Hz. This function utilizes digital zoom; therefore, the angle of view and resolution of images may be affected. However, image sensitivity is retained.

Notes

- The image stabilizer function is not effective during pan/tilt operations. It may take some time for the image to stabilize after performing pan/tilt operations.
- If the image stabilizer function is already enabled, it may take some time for the image to stabilize after turning on the power of the camera.
- Depending on the installation conditions, the image stabilizer may not be effective.
- When the image stabilizer function is enabled, the subject appears closer.

- The image stabilizer may not be effective in an installation environment where high frequency vibration is present. In this case, set the image stabilizer function to OFF.

PAN TILT ZOOM Menu

The PAN TILT ZOOM menu is used to select the pan/tilt/zoom mode.

This can be set via the Web browser.

See “PTZF control Tab” (page 63).

<PAN TILT ZOOM>	
PAN/TILT LIMIT	OFF
RIGHT	+170°
LEFT	-170°
UP	+090°
DOWN	-020°
D-ZOOM	ON
UDLR:SEL	MENU:BACK

PAN/TILT LIMIT (PAN/TILT LIMIT)

When you set PAN/TILT LIMIT to ON, you can limit the range to pan/tilt.

You can select the following values:

RIGHT: +170° to -169°, selectable in 1° steps.

LEFT: +169° to -170°, selectable in 1° steps.

UP: +90° to -29° (IMAGE FLIP:OFF)
+30° to -89° (IMAGE FLIP:ON)
selectable in 1° steps.

DOWN: +89° to -30° (IMAGE FLIP:OFF)
+29° to -90° (IMAGE FLIP:ON)
selectable in 1° steps.

Notes

- If you turn the PAN/TILT LIMIT from OFF to ON, the stored positions will be cleared. Perform PAN/TILT LIMIT first, then preset.
- If you change the PAN/TILT LIMIT settings to OFF, all set values will return to the factory settings.
- The set value displayed will be updated, when you release the joystick right/left operation. The display remains during the pan/tilt operation.
- PAN/TILT LIMIT will be applied immediately after it is set. If you want to reflect the status just before the power is turned off when turning the camera on again, set POSITION 1 to remember the setting.

Setting the range of LEFT/RIGHT movement

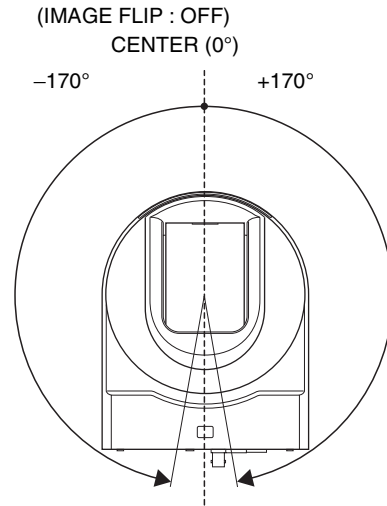

Setting the range of UP/DOWN movement

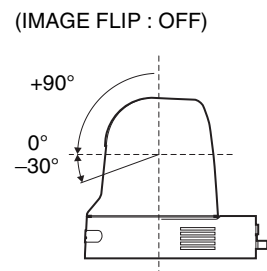

Note

When you turn the camera to the right or left beyond the 90° with the camera pointed downward by 30°, the camera may be caught on the lens, depending on the zoom position of the lens.

PAN/TILT SLOW (Slow Pan Tilt mode)

If you turn the function ON, the pan/tilt movement will slow, making it easier to shoot slow moving targets.

D-ZOOM (digital zoom)

You can set digital zoom to ON or OFF. When set to OFF, digital zoom does not operate, and only optical zoom is available. When set to ON, digital zoom takes over after optical zoom reaches MAX (×30). Up to ×360 can be zoomed digitally.

SYSTEM Menu

As this menu is for maintenance purpose, users cannot operate it.

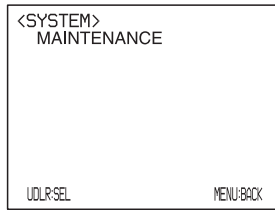

STATUS Menu

The STATUS menu is used to display the settings selected with the menus.

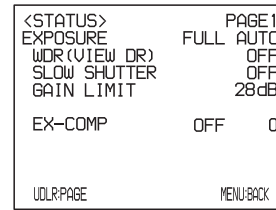

The STATUS menu consists of PAGE1 to PAGE4. This menu only displays the current menu settings, and you cannot change them with this menu.

PAGE1: Shows the settings selected with the EXPOSURE menu.

PAGE2: Items in the WHITE BALANCE menu and the PICTURE menu

PAGE3: Shows the settings selected with the PAN TILT ZOOM menu.

PAGE4: Settings of AUDIO mode, VIDEO mode, and VISCA transmission baud rate

Note

The current video format and the VISCA baud rate communication for the camera are displayed. If you adjust BAUD RATE and SYSTEM SELECT switches on the back after you turn on the power, these new settings are ignored and not changed on the display.

Operation Using the Supplied Infrared Remote Commander

Before Operating

Before operating the camera, check that the camera and peripheral devices are properly installed and connected.

For details, see “Setting of the SYSTEM SELECT switch” (page 9), “Installing the Camera” (page 16) and “Connections” (page 19).

Note

The supplied infrared remote commander may not work correctly near the inverter lighting fixtures. In such a case, try to install the camera far from the inverted luminaire. You can check whether or not the installed location is good for the usage of the infrared remote commander.

Turning on the Power

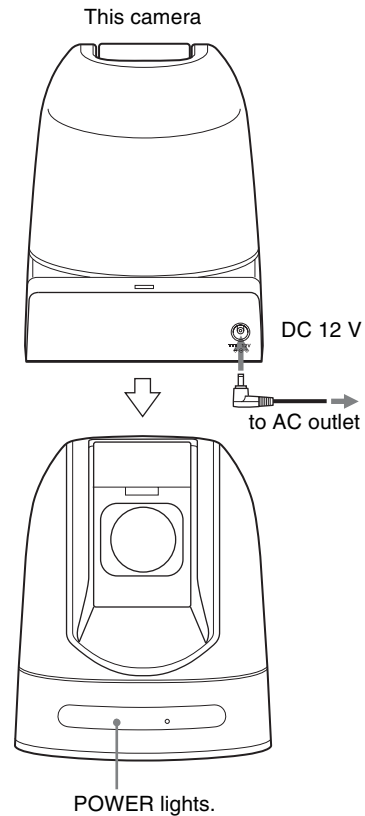

- 1 Connect the camera to an AC outlet using the supplied AC power adaptor and AC power cable or to a LAN connector for PoE+. The power is turned on and the POWER light turns on. The camera automatically pans and tilts to come to the position stored in POSITION 1 when the power is turned on. (Pan/Tilt reset) After this, SDI OUT and HDMI OUT images are output and the NETWORK light comes on. Then, all operations become available (up to two minutes).

Note

When power is supplied via PoE+, the POWER light does not come on until the initial authentication is completed (the time varies depending on the model; it is approximately one minute).

2 Turn on the peripheral devices.

To switch ON/OFF the video output using the infrared remote commander

You can switch ON/OFF the video output using the POWER switch on the infrared remote commander when supplying power to the camera.

When the POWER is off, the POWER/NETWORK lamp will go out.

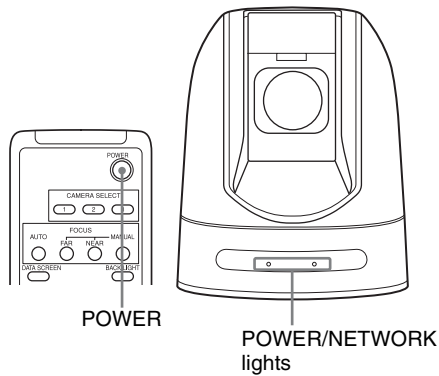

Pan/Tilt and Zoom Operation

Panning and Tilting

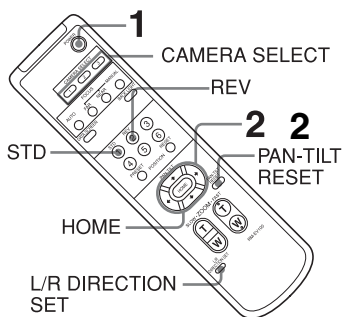

1 Press the POWER switch.
You can turn on and off the video output of the unit. When it is ON, the camera automatically resets pan/tilt and moves the Preset1 position.

2 Press the arrow button to pan or tilt the camera. While checking the picture on the screen, press the desired arrow button.
To move the camera little by little, press the button just for a moment.
To move the camera in a wide range, press and hold the button.
To move the camera diagonally, press the ◀ or ▶ button while holding down the ▲ or ▼ button.

To face the camera back to the front
Press the HOME button.

If the camera moves in a different direction from the one you intended

The camera is preset so that the image output from the camera is rotated toward the right whenever you press the ▶ button.

To face the camera toward the opposite direction

You might wish to face the camera toward the opposite direction from that of the button you pressed, for example, when you change the direction of the camera while checking the picture on the screen. In such a case, press the 2 (REV) button while holding down the L/R DIRECTION SET button.

Arrow button	Movement of the camera	Setting
		 While holding down Press

To reset the setting

To reset the setting, press the 1 (STD) button while holding down the L/R DIRECTION SET button.

Arrow button	Movement of the camera	Setting
		 While holding down Press

Note

The setting above only changes the signal emitted from the infrared remote commander, and does not change the setting of the camera itself. Therefore, repeat the setting for each infrared remote commander if you are using more than one infrared remote commander.

Zooming

Press either of the ZOOM buttons.

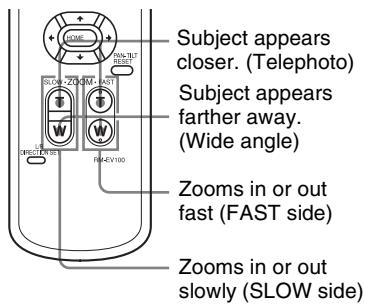

Note

When you perform pan/tilt operation while the camera is in the telephoto mode, the moving speed of the image on the screen may be a little jerky.

Operating Multiple Cameras with the Infrared Remote Commander

- 1 Set the IR SELECT switch on the rear of the camera you want to operate to 1, 2 or 3.



- 2 Press the CAMERA SELECT button on the infrared remote commander that corresponds to the number set in step 1.

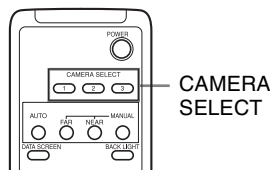

Then, you can operate the camera(s) specified by number. Every time you operate the camera(s) using the infrared remote commander, the CAMERA SELECT button pressed in step 2 lights.

Adjusting the Camera

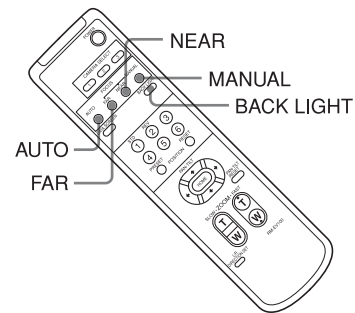

Focusing on a Subject

Focusing the camera on a subject automatically

Press the AUTO button.

The camera focuses on the subject at the center of the screen automatically.

Focusing the camera on a subject manually

After pressing the MANUAL button, press either the FAR or the NEAR button to have the camera focus on the subject.

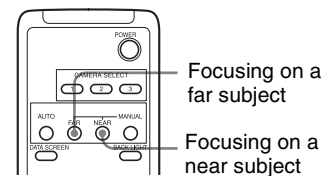

Shooting with Back Lighting

When you shoot a subject with a light source behind it, the subject becomes dark. In such a case, press the BACK LIGHT button.

To cancel the function, press the BACK LIGHT button again.

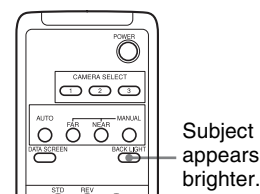

Note

The BACK LIGHT function is effective if MODE is set to FULL AUTO in the EXPOSURE menu of the camera.

Presetting Feature

Up to 6 combinations of settings (6 positions) including camera position, zooming, focusing, and backlighting, can be preset.

For details of the camera settings to be preset, see “Initial value and preset” (page 71).

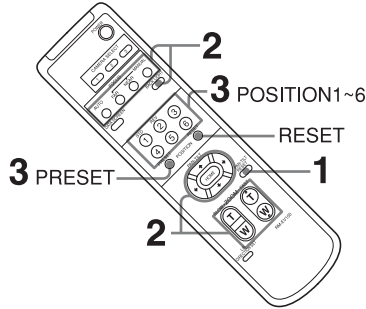

- 1** Press the PAN-TILT RESET button to reset the pan/tilt position.
- 2** Adjust the position, zooming, focusing and backlighting of the camera (pages 30 and 31).
- 3** While holding down the PRESET button, press any of the POSITION buttons, 1 to 6, in which you want to store the settings.

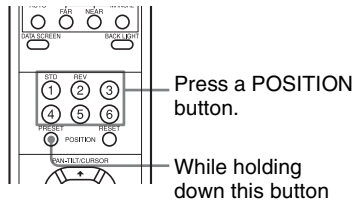

Recalling the stored settings

Press any of the POSITION buttons, 1 to 6, in which you have stored the settings.

Cancelling the preset memory

While holding down the RESET button, press the POSITION button from which you want to cancel the settings.

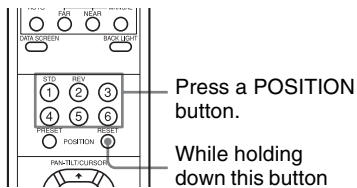

Notes

- When the power is turned on, the camera starts with the settings stored in POSITION 1.
- If you want to retain the previous pan and tilt positions, etc. before the power is turned off and turned on again, store those positions in POSITION 1.
- When you are storing or cancelling the settings in one POSITION, you cannot call up, store or cancel the settings in another POSITION.
- You can register, call, or delete the preset even while the menu is being displayed. However, you cannot change the position with the pan/tilt operation.
- If you turn the PAN/TILT LIMIT from OFF to ON, the stored positions will be cleared. Perform PAN/TILT LIMIT first, then preset.
- Please note that if you flip the image, the set position will be cleared.

PTZ TRACE Feature

You can record and playback up to eight different operations of pan, tilt, and zoom to the maximum length of 180 seconds using the infrared remote control.

Notes

- Other operations are not available during recording or playing back.
- Since Positions 1 through 6 of the infrared remote control are used for playback, be sure that they do not overlap with preset functions.
- Since the IR remote commander has only POSITION 1 through 6 buttons, 7 and 8 cannot be played back.
- If you turn the PAN/TILT LIMIT from OFF to ON, the stored operation will be cleared.
Perform PAN/TILT LIMIT first, then preset.
- Please note that if you flip the image, the stored operation will be cleared.

Recording pan/tilt/zoom operations

- 1** Press the DATA SCREEN button on the infrared remote control to display the main menu.
Using the arrow buttons, move the cursor to select **PTZ TRACE**. Press the HOME button to open the **PTZ TRACE** menu.
- 2** On the TRACE NO setting items in the **PTZ TRACE** menu, use the arrow buttons to select the number you want to register.
This TRACE NO value will be the POSITION NO of the infrared remote control during playback.
- 3** On the ACTION setting items, use the right or left arrow buttons to select START POSITION SET.
Pressing the HOME button allows you to pan/tilt/zoom with the arrow and ZOOM buttons. Press the HOME button again when the camera moves to the initial position to start recording.
The initial position settings will be completed.
- 4** On the ACTION setting items, use the arrow buttons to select RECORD/STOP.
The recording starts when you press the HOME button (the MENU screen does not get turned off).
- 5** When operation recording starts, the REMAIN (SEC) countdown will start. The recording will finish when the count reaches 0 or when the HOME button is pressed again.
- 6** You can review your recorded operation when you press the HOME button after selecting PREVIEW using the arrow buttons on the ACTION menu.

Playing back pan/tilt/zoom operations

- 1** When the menu is not displayed, press the POSITION NO button of the same number as the TRACE NO you want to playback once.
Move to the playback start position.
- 2** When you press the same button again, the stored playback of pan/tilt/zoom operation starts.
- 3** Press the HOME button during the recording playback to end the playback immediately.
- 4** If you operate pan/tilt/zoom during playback, the playback ends immediately and then it follows the pan/tilt/zoom operation via the remote control.

Note

There is no pause feature.

Deleting pan/tilt/zoom operations

- 1** Press the DATA SCREEN button on the infrared remote control to display the main menu.
Using the arrow buttons, move the cursor to select **PTZ TRACE**.
- 2** On the TRACE NO menu, use the right and left arrow buttons to select the number you want to delete.
- 3** On the ACTION menu, use the right and left arrow buttons to select DELETE.
The recording is deleted when you press the HOME button.

Operation Using the Remote Controller

This chapter describes how to operate the camera using the optional remote controller.

When you make the settings of the camera using the remote controller, see “Setting with the Remote Controller” on page 40.

Before operating, check that the camera, the remote controller, and peripheral devices are properly installed and connected.

For details, see “System Configuration” on page 12.

Notes

- You can select the IP connection and the serial connection (RS-422) for the connection between the camera and the remote controller. Set the communication speed of the VISCA RS-422 connector of the connected camera using the serial connection to be the same speed of the remote controller. For details, see “Location and Function of Parts and Controls” — “BAUD RATE switch” (page 8).
- When performing the IP output of video and audio, the response of the camera to operation from the remote controller may delay.
- For details of the remote controller settings, see the Operating Instructions of the remote controller.

Preparation

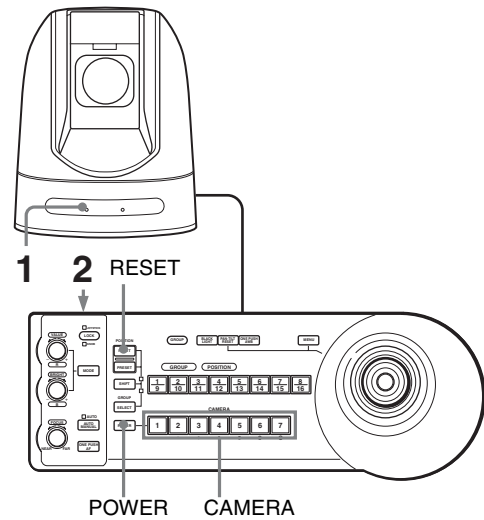

- 1 Connect the camera to an AC outlet using the supplied AC power adaptor and AC power cable or to a LAN connector for PoE+.
The power is turned on and the POWER light turns on.
The camera automatically pans and tilts to come to the position stored in POSITION 1 when the power is turned on. (Pan/Tilt reset)
After this, SDI OUT and HDMI OUT images are output and the NETWORK light comes on. Then, all operations become available (up to two minutes).

Note

When power is supplied via PoE+, the POWER light does not come on until the initial authentication is completed (the time varies depending on the model; it is approximately one minute).

- 2 Press the ON/OFF switch on the remote controller to turn it on.
The CAMERA button representing the camera whose power was turned off last lights.
(The CAMERA 1 button lights by default.)
- 3 Turn on the peripheral devices.

Notes

- Be sure to turn on the power of the camera before the power of the remote controller. Otherwise, the remote controller may not recognize the connected camera.
- After turning on the power of the camera, wait more than two minutes and turn on the power of the remote controller. Otherwise, the connection may not be recognized.

Operating a Camera Using the Remote Controller

When the camera and the remote controller are connected with RS-422, only one camera can be connected to one remote controller.

When this camera is connected with RS-422, Camera Address 1 is automatically assigned.

Operating Multiple Cameras Using Multiple Remote Controllers

When using the camera and the remote controller with the IP connection, up to 112 cameras and 5 remote controllers can be operated.

For details on how to assign camera addresses, refer to the Operating Instructions supplied with the remote controller.

Pan/Tilt and Zoom Operation

Panning and Tilting

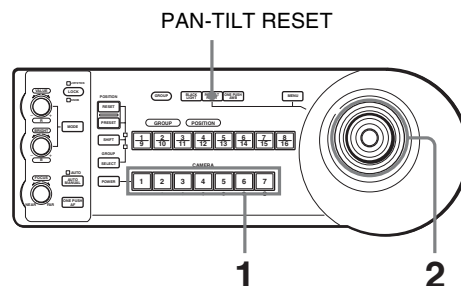

- 1** Press the CAMERA button corresponding to the camera you want to operate.
- 2** Pan or tilt the camera using the joystick. While checking the picture on the screen, incline the joystick in the desired direction. The panning/tilting speed changes according to the angle at which you incline the joystick. Release the joystick to stop panning/tilting.

To face the camera back to the front

Press the upper button on the joystick for 1 or 2 seconds.

Press for 1 or 2 seconds.

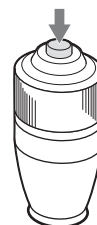

If you accidentally move the camera with your hand

Press the PAN-TILT RESET button to perform the pan/tilt reset action.

If the camera moves in a different direction from that you intended

The camera is preset to face toward the right whenever the joystick is inclined to the right. If you wish to face the camera toward the opposite direction from the direction in which you inclined the joystick, for example, when you change the direction of the camera while checking the picture on the screen. In such a case, you can change the panning direction to the opposite direction you inclined the joystick by using the L/R DIRECTION switch on the remote controller.

For details, see the Operating Instructions of the remote controller.

Note

This setting only changes the signal emitted from the remote controller and does not change the setting of the camera itself.

Zooming

Turn the dial on the upper part of the joystick.

Subject appears farther away. (Wide angle)

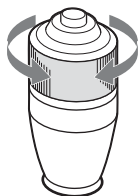

Subject appears closer. (Telephoto)

Note

When you perform pan/tilt operation while the camera is in the telephoto mode, the moving speed of the image on the screen may be a little jerky.

Adjusting the Camera

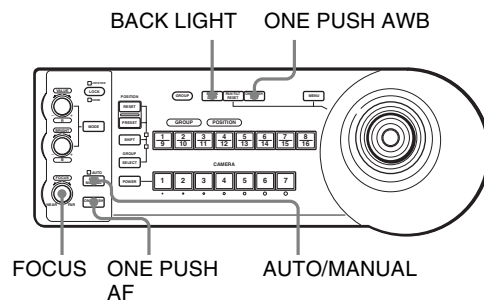

Focusing on a Subject

To focus the camera on a subject automatically

Press the AUTO/MANUAL button so that the AUTO indicator lights.

The camera focuses on the subject in the center of the screen automatically.



To focus the camera on a subject manually

Press the AUTO/MANUAL button so that the AUTO indicator turns off. Then turn the FOCUS control clockwise or counterclockwise to have the camera focus on the subject.

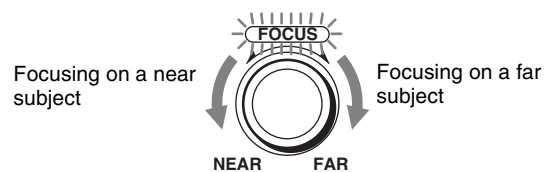

One-push auto focusing during manual focus adjustment

Press the ONE PUSH AF button. The camera focuses on the subject in the center of the screen automatically.



Shooting with Back Lighting

When you shoot a subject with a light source behind it, the subject becomes dark. In such a case, press the BACK LIGHT button.

To cancel the function, press the BACK LIGHT button again.



Note

The BACK LIGHT function is enabled only when MODE is set to FULL AUTO in the EXPOSURE menu.

Adjusting the White Balance

Before adjusting the white balance, shoot a white object that fills the entire screen under the same lighting conditions as for the object you will be zooming in on. (You can use a white wall, etc., instead of the object.) The white balance is adjusted by using this white color.

To adjust the white balance automatically

- 1 Set MODE to ONE PUSH in the WHITE BALANCE menu.

For setting, see “WHITE BALANCE Menu” on page 42.

- 2 Press ONE PUSH AWB button.
The white balance is adjusted automatically.



Presetting Feature

Up to 16 combinations of settings (16 positions), including camera position, zooming, focusing, and backlighting, can be stored in the memory of the camera using the remote controller.

For details of the camera settings to be preset, see “Initial value and preset” on page 71.

Note

Only POSITION 1 to 16 (Preset 1 to 16) are available for storing, calling, and canceling from the remote controller. Set the positions other than POSITION 1 to 16 via a Network.

Storing Camera Settings

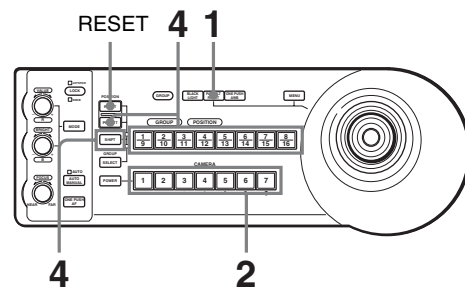

- 1 Press the PAN-TILT RESET button to reset the pan/tilt position.
- 2 Press the CAMERA button to select the camera whose settings you want to preset.

Note

When the camera and the remote controller are connected with RS-422, the camera address will be always 1. To use multiple cameras by switching, use them with the IP connection.

- 3 Adjust the position, zooming, focusing and backlighting of the camera. (See pages 35, 36, and 37.)
- 4 While holding down the PRESET button (for POSITION 1 to 8) or the PRESET button and the SHIFT button (for POSITION 9 to 16), press any of the GROUP/POSITION buttons in which you want to store the settings.

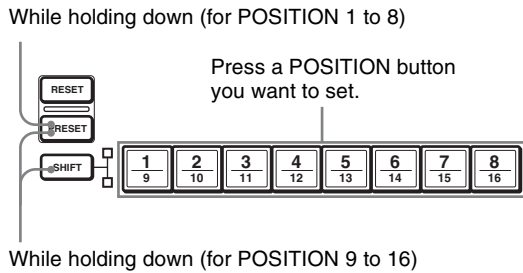

The settings are stored in the memory of the camera. The pressed button flashes during storing. Flashing stops when storing is completed.

- When you toggle the pan/tilt limit OFF to ON, the remembered position will be cleared. Perform the pan/tilt limit, then preset.
- Please note that if you flip the image, the set position will be cleared.

To recall the stored settings

Press any of the GROUP/POSITION buttons in which you have stored the settings. For POSITION 9 to 16, hold down the SHIFT button and press any of the GROUP/POSITION buttons.

To cancel the preset memory

While holding down the RESET button (for POSITION 1 to 8) or the RESET button and the SHIFT button (for POSITION 9 to 16), press the GROUP/POSITION button from which you want to cancel the settings.

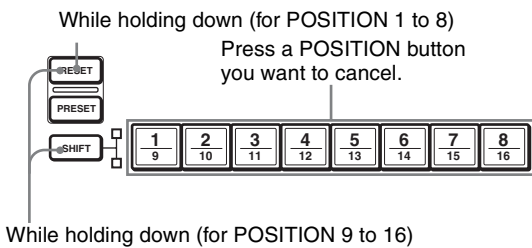

The pressed button flashes during canceling of the settings. Flashing stops when the settings have been canceled.

Notes

- When the power is turned on, the camera starts with the settings stored in POSITION 1.
- If you want to retain the previous pan and tilt positions when the power is turned off and turned on again, store those positions in POSITION 1.
- When you are storing or canceling the settings in one POSITION, you cannot call up, store or cancel the settings in another POSITION.
- When you store the position, zooming, and focusing, etc. of the camera, make sure to install and secure the camera on the place to be used properly. If you change the installations of the camera after storing the settings, the differences may occur in the settings.
- You can also set and store the camera settings in POSITION 1 to 16 with operation via a network. Also, the stored settings can be canceled with the operation via a network.
- For the setting items can be stored and canceled, see “Initial value and preset” on page 71.

PTZ TRACE Feature

You can record and play back up to eight different operations of pan, tilt, and zoom to a maximum length of 180 seconds using the remote controller.

Notes

- No other operation can be performed during recording playback.
- Since Positions 1 through 8 of the infrared remote control are used for the record playback, be sure that they do not overlap with preset functions.
- If you turn the PAN/TILT LIMIT from OFF to ON, the stored operations will be cleared. Perform PAN/TILT LIMIT first, then the record operation.
- Please note that if you flip the image, the stored operation will be cleared.

Recording pan/tilt/zoom operations

- 1** Press and hold the MENU button of the remote controller for one second or longer to view the main menu.
Using the joystick, move the cursor to select **PTZ TRACE**. Press the top button on the joystick to open the **PTZ TRACE** menu.
- 2** On the TRACE NO setting items in the **PTZ TRACE** menu, move the joystick to select the number you want to register.
TRACE NO will be the POSITION NO of the remote controller during playback.
- 3** On the ACTION setting items, move the joystick to select START POSITION SET.
Pressing the top button of the joystick allows you to pan/tilt/zoom with the joystick. Press the top button of the joystick again when the camera moves to the initial position to start recording.
The initial position settings will be completed.
- 4** On the ACTION setting items, move the joystick right or left to select RECORD/STOP.
The recording starts when you press the top button of the joystick (the MENU screen does not turn off).
- 5** The REMAIN (SEC) countdown will start as well as the recording of operation. The recording will be finished when the count reaches 0 or you press the button on the joystick again.
- 6** On the ACTION setting items, move the joystick right or left to select PREVIEW.
You can review the recorded operation when you press the top button of the joystick.

Playing back pan/tilt/zoom operations

- 1** When the menu is not displayed, press the POSITION NO button of the same number as the TRACE NO you want to playback once.
Move to the playback start position.
- 2** When you press the same button again, the stored playback of pan/tilt/zoom operation starts.
- 3** Press the HOME button during the recording playback to end the playback immediately.
- 4** If you operate the joy stick during the record playback, the playback will finish immediately and then it follows the pan/tilt/zoom operation via the joy stick.

Note

There is no pause feature.

Deleting pan/tilt/zoom operations

- 1** Press and hold the MENU button of the remote controller for one second or longer to view the main menu.
Using the joystick, move the cursor to select **PTZ TRACE**.
- 2** On the TRACE NO setting items in the **PTZ TRACE** menu, move the joystick to select the number you want to delete.
- 3** On the ACTION setting items, move the joystick right or left to select DELETE.
The recording is deleted when you press the top button of the joystick.

Setting with the Remote Controller

About On-Screen Menus

This section explains the conditions and system setup to shoot referring to the menu items displayed on the screen of the external monitor connected to the HDMI OUT/SDI OUT connector.

When you operate pan, tilt, zoom, etc. using the remote controller, see “Operation Using the Remote Controller” on page 34.

This section explains how to read the on-screen menus before starting menu operations.

For the overall menu configurations, see “Menu Configuration” on page 69.

Note

You cannot perform pan/tilt operations while the menu is displayed.
This menu is displayed on HDMI OUT/SDI OUT only.

Operating with the Remote Controller

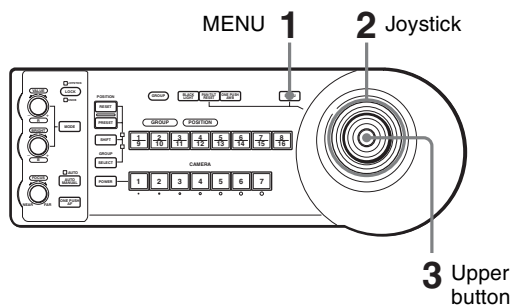

- 1 Press the MENU button of the remote controller and hold it for about 1 second.
The main menu is displayed.
- 2 Select a setting menu with the joystick.
- 3 Decide the setting menu pressing the upper button of the joystick.

Main Menu

Press the MENU button on the remote control and hold it for about 1 second to display the main menu.

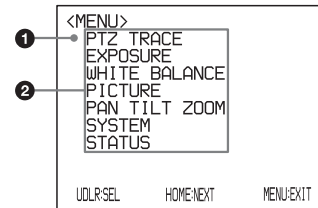

1 Selected item

Select a setting menu.

The currently selected item is shown in red.

The selected item shifts up or down when you tilt the joystick on the remote control up or down.

2 Menu items

Select a setting menu with the joystick of the remote controller and press the upper button. The selected setting menu is displayed.

The menu display position changes when you tilt the joystick to the right or left in the main menu.

Setting Menu

The setting menu selected on the main menu is displayed.

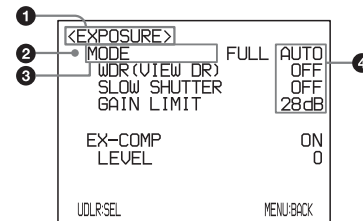

1 Setting menu

The name of the setting menu currently selected is displayed here.

2 Selected item

Select a setting item.

The currently selected item is shown in red.

The selected item shifts up or down when you tilt the joystick up or down.

3 Setting items

The setting items for this setting menu are displayed.

4 Set value

The currently set values are displayed.

To change a set value, incline the joystick of the remote controller to the right or left.

For the default value of each setting item, see “Menu Configuration” on page 69.

To cancel the menu

When the main menu is displayed, press the MENU button once. When the sub menu is displayed, press the MENU button twice.

Control Button Display Section

Main menu

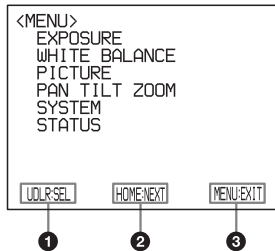

- 1 Indicates that you can select an item by inclining the joystick of the remote controller up or down. The selected item is shown in red.
- 2 Indicates that you can move to the next layer by pressing the upper button of the joystick.
- 3 Indicates that you can return to the normal display from the main menu by pressing the MENU button of the remote controller.

Setting menu

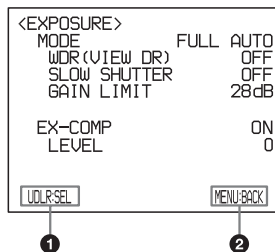

- 1 Indicates that you can select the setting item by inclining the joystick of the remote controller up or down, and you can change the set value by inclining the joystick of the remote controller right or left.
- 2 Indicates that you can return to the main menu by pressing the MENU button of the remote controller.

EXPOSURE Menu

The EXPOSURE menu is used to set the items related to the exposure.

You can also set via a Web browser.

See “Exposure” on page 54.

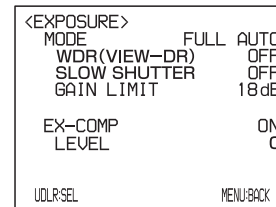

MODE (exposure mode)

FULL AUTO: The exposure is adjusted automatically using the sensitivity, electronic shutter speed, and iris.

BRIGHT: Adjust the brightness level (LEVEL).

SHUTTER PRI: The exposure is adjusted automatically using the sensitivity and iris. Adjust the electronic shutter speed (SPEED) manually.

IRIS PRI: The exposure is adjusted automatically using the sensitivity and electronic shutter speed. Adjust the iris (IRIS) manually.

MANUAL: Adjust the sensitivity (GAIN), electronic shutter speed (SPEED) and iris (IRIS) manually.

When you select one from among the various exposure modes, some of the following setting items that are required for the selected mode appear.

GAIN: Select the gain from among the following:

0, 3, 6, 9, 12, 15, 18, 21, 24, 27, 30, 33, 36, 39, 43 dB

SPEED: Select the electronic shutter speed from among the following:

For the 59.94/29.97 video format:

1/1, 1/2, 1/4, 1/8, 1/15, 1/30, 1/60, 1/90, 1/100, 1/125, 1/180, 1/250, 1/350, 1/500, 1/725, 1/1000, 1/1500, 1/2000, 1/3000, 1/4000, 1/6000, 1/10000 sec.

For the 50/25 video format:

1/1, 1/2, 1/3, 1/6, 1/12, 1/25, 1/50, 1/75, 1/100, 1/120, 1/150, 1/215, 1/300, 1/425, 1/600, 1/1000, 1/1250, 1/1750, 1/2500, 1/3500, 1/6000, 1/10000 sec.

IRIS: Select the iris from among the following:

CLOSE, F14, F11, F9.6, F8.0, F6.8, F5.6, F4.8, F4.0, F3.4, F2.8, F2.4, F2.0, F1.6

LEVEL: Select the brightness level.

Select the brightness level from among 0, 5 to 31.

WDR (VIEW-DR): When MODE (exposure mode) is set to FULL AUTO, the camera distinguishes light and dark areas in the same scene, adjusts the brightness for dark areas, and also controls the blown out highlights.

You can select the mode from among OFF, LOW, MID and HIGH.

Notes

- You can set WDR (VIEW-DR) only when MODE is set to FULL AUTO.
- When changing WDR (VIEW-DR), a change in screen luminance occurs for a moment.
- When the change of exposure is big, the screen may stop for a moment.
- The audio is muted for about 1 second when you toggle WDR (VIEW-DR).

GAIN LIMIT: Select the upper limit of the gain rise in FULL AUTO, SHUTTER PRI and IRIS PRI modes. Select from among 9, 12, 15, 18, 21, 24, 27, 30, 33, 36, 39, 43 dB.

EX-COMP (exposure compensation)

When MODE (exposure mode) is set to FULL AUTO, SHUTTER PRI, or IRIS PRI and turn this function ON, the exposure correction is enabled. When you set EX-COMP to ON, LEVEL appears and you can select the exposure compensation level from among the following: -7, -6, -5, -4, -3, -2, -1, 0, 1, 2, 3, 4, 5, 6, 7

If you set the level to 0, exposure compensation will be disabled. Level 7 is the brightest and -7 is the darkest compensation value.

When EX-COMP is set to OFF, exposure compensation does not function.

SLOW SHUTTER (slow shutter)

When you set the mode to ON, the camera automatically uses slow shutter speed for exposure as the illumination of the object to be shot decreases. This mode is available only when AE mode is set to FULL AUTO.

WHITE BALANCE Menu

The WHITE BALANCE menu is used to select the white balance mode.

You can also set via a Web browser.

See “White balance” on page 55.

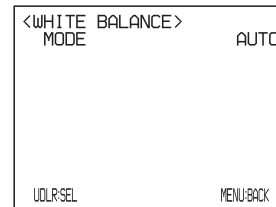

MODE (white balance mode)

Select the white balance mode from among the following: AUTO (auto), IN DOOR (indoor), OUT DOOR (outdoor), ONE PUSH (one push), ATW, MANUAL (manual)

When you select MANUAL, R.GAIN (R gain) and B.GAIN (B gain) appear. These can be adjusted within the range between 0 and 255.

When you select the ONE PUSH mode

Perform the following while the white balance menu is displayed.

- 1** Zoom in on a large white subject in the center of the screen.
- 2** Press ONE PUSH AWB button of the remote controller.
The one-push white balance adjustment is activated.

When you use the remote controller, pressing the ONE PUSH AWB button on the remote controller performs ONE PUSH AWS even if the menu screen is not displayed.

PICTURE Menu

The PICTURE menu is used to set the items related to the picture.

You can also set via a Web browser.

See “Picture” on page 56 or “Installation Tab” on page 52.

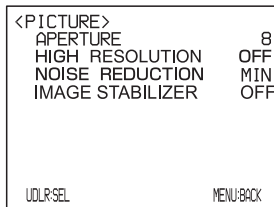

- The image stabilizer may not be effective under environments with high frequency vibration. To use the camera in such environments, set the image stabilizer function to OFF.

APERTURE (aperture compensation)

Select the aperture compensation level from among MIN, 1 to 14 and MAX.

HIGH RESOLUTION (high resolution mode)

You can select ON/OFF of HIGH RESOLUTION (high resolution mode). When set to ON, you can enjoy emphasized edge and high-resolution images.

Note

When set to ON, the image is noisier than when set to OFF.

NOISE REDUCTION (noise reduction)

You can enjoy clearer images by removing unnecessary noise (fixed pattern and randomized noise). You can select 6 levels from OFF (MIN) to 5 (MAX).

IMAGE STABILIZER (image stabilizer)

You can select the effect of image stabilizer according to the shooting conditions.

OFF: The image stabilization feature becomes disabled.

ON: The image stabilization feature becomes enabled.

When set to ON, you can obtain steadier images if vibration is present. This stabilizer is effective for vibration frequencies around 10 Hz. This function utilizes digital zoom; therefore, the angle of view and resolution of images may be affected. However, image sensitivity is retained.

Notes

- The image stabilizer function is not effective during pan/tilt operations. It may take some time for the image to stabilize after stopping pan/tilt operations.
- If the image stabilizer function is enabled, it may take some time for the image to stabilize after turning on the power of the camera.
- Depending on the installation conditions, the image stabilizer may not be effective.
- When the image stabilizer function is enabled, the subject appears closer.

PAN TILT ZOOM Menu

The PAN TILT ZOOM menu is used to select the pan/tilt/zoom mode.

You can also set via a Web browser.
See “PTZF control Tab” on page 63.

<PAN TILT ZOOM>	
PAN/TILT LIMIT	OFF
RIGHT	+170°
LEFT	-170°
UP	+090°
DOWN	-020°
PAN/TILT SLOW	OFF
D-ZOOM	ON
UDLRSEL	MENU/BACK

PAN/TILT LIMIT (pan/tilt limit)

Set PAN/TILT LIMIT to ON to limit the range of pan/tilt.

You can select the following values:

RIGHT: +170° to -169°, selectable in 1° steps.

LEFT: +169° to -170°, selectable in 1° steps.

UP: +90° to -29° (IMAGE FLIP: OFF)

+30° to -89° (IMAGE FLIP: ON)

Selectable in 1° steps.

DOWN: +89° to -30° (IMAGE FLIP: OFF)

+29° to -90° (IMAGE FLIP: ON)

Selectable in 1° steps.

Notes

- If you change PAN/TILT LIMIT to OFF, the set values will be returned to the factory settings.
- If you set PAN/TILT LIMIT to OFF, the set values will be returned to the factory settings.
- The set value displayed will be updated when you release the joystick right/left operation. The display does not change during the pan/tilt operation.
- The PAN/TILT LIMIT will be applied immediately after it is set. If you want to reflect the status just before the power is turned off when turning the camera on again, set POSITION 1 to remember the setting.

Setting the range of the RIGHT/LEFT movement

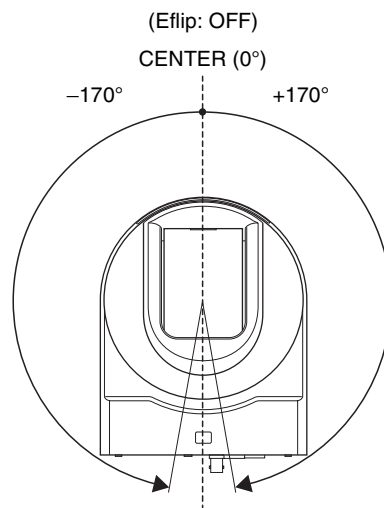

Setting the range of the UP/DOWN movement

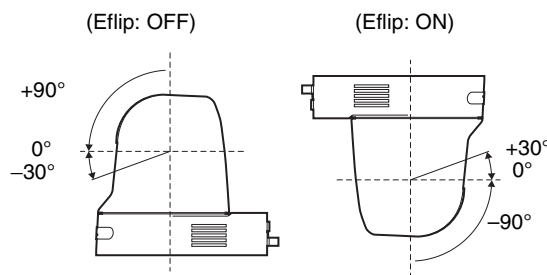

Note

When you turn the camera to the right or left beyond the 100° with the camera pointed downward by 30°, the camera may be caught on the lens, depending on the zoom position of the lens.

PAN/TILT SLOW (Slow Pan Tilt mode)

When this function is set to ON, the active speed of PAN/TILT LIMIT will be slow, making it easy to shoot slow-moving objects.

D-ZOOM (digital zoom)

You can set digital zoom to ON or OFF. When set to OFF, digital zoom does not operate, and only optical zoom is available. When set to ON, digital zoom takes over after optical zoom reaches MAX (×30). Up to maximum ×360 can be zoomed digitally.

SYSTEM Menu

As this menu is for maintenance purpose, users cannot operate it.

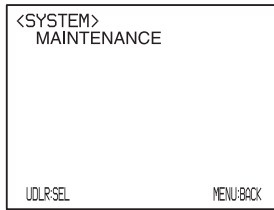

STATUS Menu

The STATUS menu is used to display the settings selected with the menus.

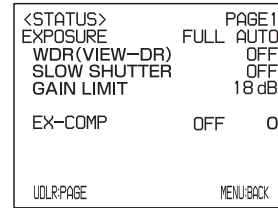

The STATUS menu consists of PAGE1 to PAGE4. This menu only displays the current menu settings, and you cannot change them with this menu.

PAGE1: Shows the settings selected with the EXPOSURE menu.

PAGE2: Items in the WHITE BALANCE menu and the PICTURE menu

PAGE3: Shows the settings selected with the PAN TILT ZOOM menu.

PAGE4: Settings of AUDIO mode, VIDEO mode, and VISCA transmission baud rate

Note

The currently functioning settings will be displayed for the VISCA communication baud rate and VIDEO modes. Even if you change the setting of the BAUD RATE switch or SYSTEM SELECT switch on the rear side, those settings will be discarded and the display does not switch.

Operating the Camera Via a Network

This section explains how to monitor the image from the camera using your Web browser.

The functions of the camera should be set by the Administrator. For the setting of the camera, see “Setting the Camera Via a Network” on page 51.

When you operate pan, tilt, zoom, etc. using the remote controller, see “Operation Using the Remote Controller” on page 34.

Notes

- Do not operate the camera via a network or use a remote controller at the same time.
- About 2 minutes after turning on the power, the camera will automatically reset to the pan/tilt position and the camera settings stored in Preset 1 (Pan/tilt reset action). For the setting items retained in the memory when starting the camera, see “Initial value and preset” on page 71.
- If the camera settings are not stored in Preset 1, the camera settings are cleared from the memory and reset to the default settings when the power is turned on.

Accessing the Camera Using the Web Browser

Check that you can actually access the camera using the Web browser installed on your computer.

- 1** Assign an IP address to the camera.
The IP address can be changed via **Network** menu under the **Administrator Settings** menu. The factory setting is IP [192.168.0.100].
- 2** Start the Web browser on the computer and type the IP address of the camera in the URL address bar.



The live viewer window is displayed.

Display sample:

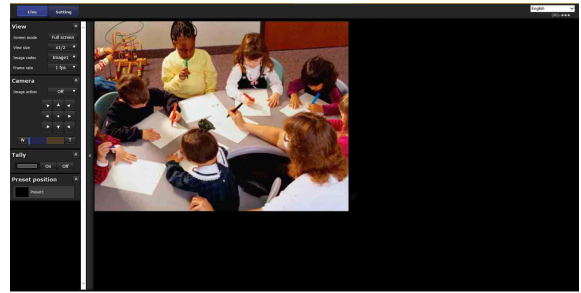

Notes

- The maximum number of users who can watch the viewer concurrently for video is 5. However, if the transmission ability of the camera is overloaded, access to the camera may not be possible, even if there are fewer than 5 users.
- If the simultaneous connections via a network increase, the frame rate may decrease.

About Viewers

Plug-in free viewer

This is a viewer to view images on the Web browser.

Notes

- If Automatic configuration is enabled in the Local Area Network (LAN) settings of Internet Option, the image may not be displayed. In that case, set the proxy server manually without using Automatic configuration. For the setting of the proxy server, consult your network administrator.
- Displayable frame rate is up to around 10 fps.

Tip

Every page of this software is optimized for Internet Explorer in **Medium** font.

To display the viewer correctly

To operate the viewer correctly, set the security level of Internet Explorer to **Medium** or lower, as follows:

- 1** Select **Tools** from the menu bar for Internet Explorer, then select **Internet Options** and click the **Security** tab.
- 2** Click the **Internet** icon (when using the camera via the Internet), or **Local intranet** icon (when using the camera via a local network).
- 3** Set the slider to **Medium** or lower. (If the slider is not displayed, click **Default Level**.)

When using antivirus software, etc., on the computer

- When you use antivirus software, security software, personal firewall or pop-up blocker on your computer, the camera performance may be reduced, for example, the frame rate for displaying the image may be lower.
- The Web page displayed when you log in to the camera uses JavaScript. The display of the Web page may be affected if you use antivirus software or other software described above on your computer.

Operating the Camera

This section explains the functions of the parts and controls of the live viewer. For a detailed explanation on each part or control, see the specified pages.

Live viewer

Main menu

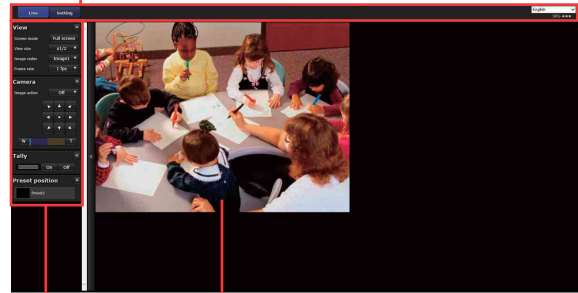

Control panel section

Monitor screen

Main menu

Live

Displays the live viewer screen through the Plug-in free viewer.

Setting

Click to display the Administrator menu. (page 51)
You need to log in as an Administrator to operate this function.



Language

Set the language to be used in the viewer display.

Monitor screen

The image shot with the camera is shown here. You can operate the pan, tilt, zoom using the mouse.

Operation panels

The advanced settings screen will be hidden when you click  for each panel. It will be shown when you click  again.

View panel

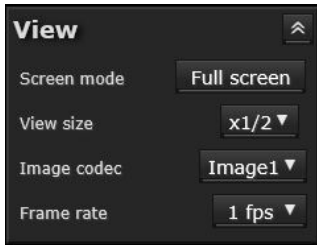

You can change the screen mode, view size of the image, image codec, and frame rate.

Screen mode

Select the display mode of the live viewer from **Window** or **Full screen**.

View size

Selects the view size of the monitor screen.

Select **x1/4** to display images, reduced to 1/4 of the size set in **Image size**.

Select **x1/2** to display images, reduced to 1/2 of the size set in **Image size**.

Select **x1** to display images set in **Image size** (page 54) of the Video menu.

Select **Full** to display images according to the view size. Select **Fit** to display images according to the view size, with fixed aspect ratio.

Image codec

Select the image codec setting of the image displayed on the monitor screen from **Image 1**, **Image 2**, and **Image 3**.

Frame rate

Select the frame rate to transmit images.

Note

Displayable frame rate is up to around 10 fps.

Camera control panel



You can operate the pan/tilt, moving to the home position, zoom, and focus of the camera by using the control panel for the monitor image currently displayed (page 49).

Image action



Select the mode of image operation between **Off** and **Area zoom**.

Pan/Tilt control

Click the arrow button the direction in which you want to move the camera. Keep it pressed to move the camera continuously.

To return to the home position, click . When returning to the home position, the positions of pan, tilt, zoom, and focus is returned to the factory setting.

Zoom control

Click  to zoom out, and click  to zoom in.

Zooming continues while the button remains pressed.



Note

The four edges of the image may be dark depending on the zoom position. This is a phenomenon related to the structure of the camera, and does not cause a problem.

Focus control

This function is displayed when **Focus mode** is set to **Manual** in the PTZF control menu (page 63).

Tally panel

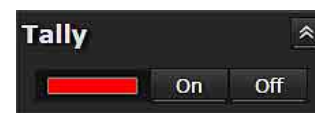

This is lit when the camera Tally lamp is On. When it is Off, the light will be off.

Preset position panel



Displays only when one or more preset positions are stored in memory.

Displays the registered preset positions.

If you select a thumbnail when registering a preset position, it will be displayed with a thumbnail.

Select the Preset position name from the list. The camera will move to the preset position that you have stored in memory using the Preset position menu.

Note

No audio is output if the Plug-in free viewer is used.

Pan/Tilt and Zoom Operation

To operate pan/tilt/zoom of the camera, there are three operations: “Controlling via the control panel,” “Controlling via the preset position panel,” and “Controlling using the monitor screen.” “Controlling using the monitor screen” includes 2 modes, **Area zoom** and **PTZ control bar**.

Controlling via the control panel

You can operate the pan/tilt, moving to the home position, zoom, and focus of the camera by using the control panel for the monitor image currently displayed.



Image action



Select the image operation method between **Off** and **Area zoom**.

Pan/Tilt control

Click the arrow button in the direction in which you want to move the camera. Continue clicking on the arrow to keep moving the direction of the camera.

To return to the home position, click . When returning to the home position, the positions of pan, tilt, zoom, and focus is returned to the factory setting.

Zoom control

Click  to zoom out, and click  to zoom in.

Zooming continues while the button remains pressed.



Indicates the available area of optical zoom.

Indicates the available area of digital zoom.

Note

The four edges of the image may be dark depending on the zoom position. This is a phenomenon related to the structure of the camera, and does not cause a problem.

Controlling via the preset position panel



The preset position registered in the memory is displayed on the preset position panel.

When selecting a preset position name from the preset position panel, the camera will move to the preset position.

Register the preset position using the Preset position tab of the PTZF control menu (page 64).

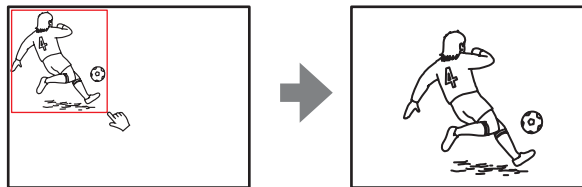

Note

When the specified area is zoomed in, the center may be shifted or some portion of the image may appear out of the monitor image section. In this case, click the point you want to move to the center or click the arrow button on the camera control panel.

Controlling using the monitor screen

There are two operations for pan/tilt/zoom on the image: Area zoom mode and PTZ control bar, where you click on the control bar.

• Area zoom mode

By clicking an image, the camera moves to the direction where the clicked point will be the center of the image. The Area zoom will move the camera in the direction that displays the area selected by the operator and zooms in at the same time. The operator can choose a part of the image to view and zoom in by surrounding the area with a frame by dragging the mouse. The zoom operation using the mouse wheel is available.

Panning and tilting by clicking the screen (Area zoom mode)

Click on the monitor image, and the camera moves so that the clicked portion is positioned at the center of the image.

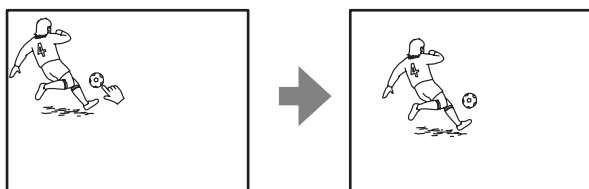

Panning, tilting and zooming by specifying the area (Area zoom mode)

Click and hold the left button of the mouse on the monitor image, and drag the mouse diagonally to draw a red frame around the portion you want to enlarge. The camera moves so that framed portion is positioned at the center of the display and is zoomed in.

Setting the Camera Via a Network

This section explains how to set the functions of the camera by an Administrator.

For details concerning the monitoring of the camera image, see “Operating the Camera Via a Network” on page 46.

When you make the settings of the camera using the remote controller, see “Setting with the Remote Controller” on page 40.

This section explains the basic operations and each option of the Administrator menu.

Note on the display of menu options

The setting menus of this unit will clearly display only the setting options that you can currently select. Grayed out options cannot be selected.

Only supported functions are displayed.

Basic Operations of the Administrator Menu

You can use the Administrator menu to set all functions to suit the user’s needs.

Click **Setting** in the viewer to display the Administrator menu.

How to set up the Administrator menu

- 1 Access to the camera to display the viewer.
For details, see “Accessing the Camera Using the Web Browser” on page 46.
- 2 Click **Setting** on the main menu.
The authentication dialog appears. Enter the user name and password for Administrator. The Administrator menu appears.
For the administrator, the factory set user name is “admin” and the factory set password is “Admin_1234”.
Change the password from the factory setting for the security of your devices.
- 3 Click the menu name (example: System) on the left side of the Administrator menu.
The clicked menu appears.
Example: “System” menu



- 4 Select the required tab above the menu, and set each setting option in the tab.

Example: “Installation” tab of “System” menu

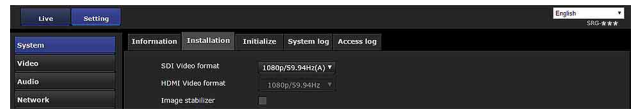

See page 52 for details of the menu tabs and setting options.

- 5 After setting, click **OK**.
The settings you have made become active.

Click **Cancel** to nullify the set values and return to the previous settings.

Buttons common to every menu

The following common buttons are displayed in the tab of each menu as required.

OK

Click this button to enable the settings in each tab. The settings are not reflected in the camera unless this button is clicked.

Cancel

Click this button to nullify the set values and return to the previous settings.

General notes on menus

- One-byte katakana character is not valid for any text field, such as User name.
- After changing a setting on a menu, wait at least 2 minutes before turning off the power of the camera. If the power is turned off immediately, the new setting may not be stored correctly.
- If the camera settings are changed while watching the live viewer, some settings cannot be restored. To reflect the change on the opening live viewer, click **Refresh** on the Web browser.

Configuration of the Administrator menu

System

Displays the System menu. (“System Menu” on page 52)

Video

Displays the Video menu for setting the camera image. (“Video Menu” on page 54)

Audio

Displays the Audio menu for setting the camera audio. (“Audio Menu” on page 58)

Network

Displays the Network menu for setting the network connection. (“Network Menu” on page 59)

Security

Displays the Security menu for setting the login user specification and the computer(s) can connected to the camera. (“Security Menu” on page 61)

PTZF control

Displays the PTZF menu for setting pan, tilt, zoom, and focus operations. (“PTZF control Menu” on page 63)

Streaming

Displays the Streaming menu for setting sending. (“Streaming Menu” on page 65)

System Menu

When you click **System** in the Administrator menu, the System menu appears.

Use this menu to perform the principal settings of the software.

The System menu consists of the following tabs:

Information, Installation, Initialize, System log and Access log.

Information Tab

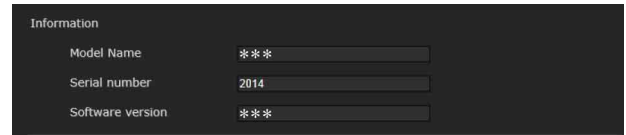

Model Name

The model name of the camera is displayed.

Serial number

The serial number of the camera is displayed.

Software version

The software version of the camera is displayed.

Installation Tab

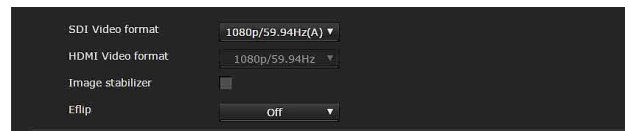

You can perform settings related to installation.

SDI Video format

Set the video format of the signal to be output from the SDI OUT connector.

	Video format
59.94 Hz system	1920 × 1080p/59.94 (A)
	1920 × 1080p/59.94 (B)
	1920 × 1080i/59.94
	1920 × 1080p/29.97
	1280 × 720p/59.94
	1280 × 720p/29.97
50 Hz system	1920 × 1080p/50 (A)
	1920 × 1080p/50 (B)
	1920 × 1080i/50
	1920 × 1080p/25
	1280 × 720p/50
	1280 × 720p/25

Notes

- To enable settings via WEB UI, select “7” for the SYSTEM SELECT switch on the back, and turn power on again.
- The frame rate and image size that can be selected for the IP image may differ depending on the video format.
- After changing the video format, the PTZF position is returned to the position originally set when starting the camera and the video codec setting is returned to the default setting in accordance with the SDI video format.

HDMI Video format

If you change the SDI video format, the HDMI video format will be changed automatically.
To change the HDMI video format, change the SDI video format.

Note

You cannot configure using this menu.

Image stabilizer

Set the image stabilizer function. Select the checkbox to display steadier images when the camera is installed in a place subject to vibration.

Notes

- When the image stabilizer function is set, the angle of images taken will be smaller than usual.
- The image stabilizer may not respond depending on the amount of vibration.
- Be sure to set this function during the installation.

Eflip

Flip an image vertically. This function is set to **Off** normally. When installing the camera to ceilings, set it to **On**.

Note

If you switch On/Off of the Eflip function, all preset settings and pan-tilt limit settings are deleted. The video codec setting is returned to the default setting in accordance with the SDI video format.

Initialize Tab

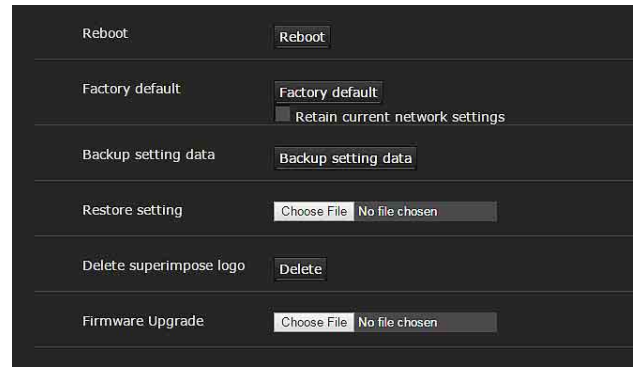

Reboot

Used when rebooting the system.
Click **Reboot**, and the message “This System will be rebooted. Are you sure?” appears. Click **OK** to reboot the camera. It takes about two minutes to restart.

Factory default

Resets the camera to the factory settings.

Retain current network settings

Factory settings for IP

IP address: 192.168.0.100

Subnet mask: 255.255.255.0

When this item is checked, only the current network settings will be retained after reset.

Click **Factory default**, and the message “This System will be rebooted. Are you sure?” appears.

When you click **OK**, the network indicator on the camera starts to blink. After adjustments of the default settings have finished, the camera reboots automatically. Do not turn off the camera until the camera reboots.

Backup setting data

Saves the setting data of the camera in a file.

Click **Backup setting data**, and follow the instructions on the Web browser to specify the folder and save the setting data of the camera.

Restore setting

Loads the stored setting data of the camera.

Click **Choose File** and select the file in which the setting data is stored. Click **OK**, and the camera is adjusted according to the loaded data.

Delete superimpose logo

Click **Delete** to delete the superimposed logo, specified by Position in the Superimpose tab of the Video menu, from the camera.

To set whether to show or hide the superimpose logo, you need to configure the setting under the Superimpose tab.

Firmware Upgrade

Use this to upgrade the firmware. Click **Select the file** and select the firmware to upgrade, then click **Open**.

The confirmation dialog is displayed. Operate according to the contents.

System log Tab

The data of the software activity of the camera is recorded in this log. It includes data that is useful if a problem occurs.

Click **Reload** to reload the latest data.

Access log Tab

The access record of the camera is displayed.

Click **Reload** to reload the latest data.

Video Menu

When you click **Video** in the Administrator menu, the Video menu appears.

Use this menu to set the functions of the camera.

The Video menu consists of the **Picture**, **Video codec**, **Superimpose**, and **Day/Night ICR** tabs.

Picture Tab

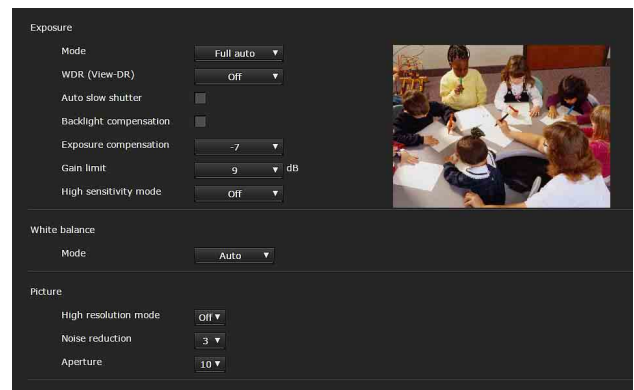

You can set the color conditions, exposure, etc., of the camera.

Preview screen

Preview the image and adjust the picture setting.

Exposure

You can also set from the remote controller. See “EXPOSURE Menu” on page 41.

Mode

Adjust the settings of exposure.

Full auto: The camera performs the gain, iris and shutter speed adjustments automatically.

Shutter priority: The camera performs the gain and iris adjustments automatically, and you can select the shutter speed.

Iris priority: The camera performs the gain and shutter speed adjustments automatically, and you can select the iris.

Manual: Adjust the gain, iris and shutter speed manually.

Bright: Adjust the brightness level (combined with gain or iris) of the camera.

Note

When the gain limit setting is set to a value other than 43 dB (maximum), the brightness level range is also limited.

WDR (VIEW-DR)

In high-contrast scenes such as against a back light, this function reduces overexposure and underexposure. This function is enabled if the setting values other than **Off** are selected from the list box. This function is enabled only when **Mode** is set to **Full auto**.

Notes

- When the function is enabled, a change in screen luminance occurs for a moment.
- When the change of exposure is great, the screen may stop for a moment.

Auto slow shutter

The automatic slow shutter function is enabled when the check box is checked. This function can be selected only when **Mode** is set to **Full auto**.

Backlight compensation

Select the checkbox to enable the backlight compensation function. This function is enabled only when **Mode** is set to **Full auto**.

Exposure compensation

Select the exposure correction value from the list box to adjust the target brightness for the automatic exposure setting. Select high values to make the image brighter, lower values to make the image darker. This function can be selected only when **Mode** is set to **Full auto**, **Shutter priority**, **Iris priority**.

Gain limit

Select the maximum gain value of automatic exposure control from the list box. This function can be selected only when **Mode** is set to **Full auto**, **Shutter priority**, **Iris priority**.

Note

The value shown in the auto gain maximum rate is a standard value, and may differ from the actual one.

Shutter speed

Select the shutter speed from the list box. This function can be selected only when **Mode** is set to **Shutter priority**, **Manual**.

Note

When you change the current shutter speed setting value to a value that differs greatly, it may take some time to reflect the setting value.

During that time, the setting value on the display does not match with the actual setting value. By reloading the browser, the correct setting value is displayed.

Iris

Select the amount of iris (F value) from the list box. This function can be selected only when **Mode** is set to **Iris priority**, **Manual**.

Note

When you change the current F value to a value that differs greatly, it may take some time to reflect the setting value.

During that time, the setting value on the display does not match with the actual setting value. By reloading the browser, the correct setting value is displayed.

Gain

Select the gain from the list box. This function can be selected only when **Mode** is set to **Manual**.

Level

Select the bright level from the list box. This function can be selected only when **Mode** is set to **Bright**.

High sensitivity mode

Select **On/Off** of the high sensitivity mode from the list box.

When set to **On**, the high-sensitivity gain is amplified according to the increase of general gain value. This function can be selected in all modes.

Note

When set to **On**, the image is noisier than when set to **Off**.

White balance

You can also set from the remote controller. See “WHITE BALANCE Menu” on page 42.

Mode

Select the White balance mode.

Auto: Automatically adjusts the color to be closest to the image you are viewing (approximately 2500 K to 6000 K).

ATW: Eliminating the influences caused by environmental illumination or lights, adjust the white balance automatically to reproduce original colors of the objects (approximately 2000 K to 10000 K).

Indoor: Sets a white balance suitable for indoor photography.

Outdoor: Sets a white balance suitable for outdoor photography.

One push WB: The **One push trigger** button becomes active. Click **On** to adjust the white balance instantly. Shoot and zoom with a large white subject in the center of the screen before adjustment.

Manual: When this option is selected, **R gain** and **B gain** become active. Selectable gain values are from 0 to 255.

Picture

You can also set from the remote controller.
See “PICTURE Menu” on page 43.

High resolution mode

Select **On/Off** of the high resolution mode. When set to **On**, you can enjoy emphasised edge and high-resolution images.

Noise reduction

You can enjoy clearer images by removing unnecessary noise (fixed pattern and randomized noise).
You can select **Off** (MIN) or 5 levels from **1** to **5** (MAX) for noise reduction.

Aperture

Set the sharpness. Select high values to make the image edges sharper, lower values to make the image edges smoother.
You can select from 0 (MIN), 1 to 14, and 15 (MAX).

Video codec Tab

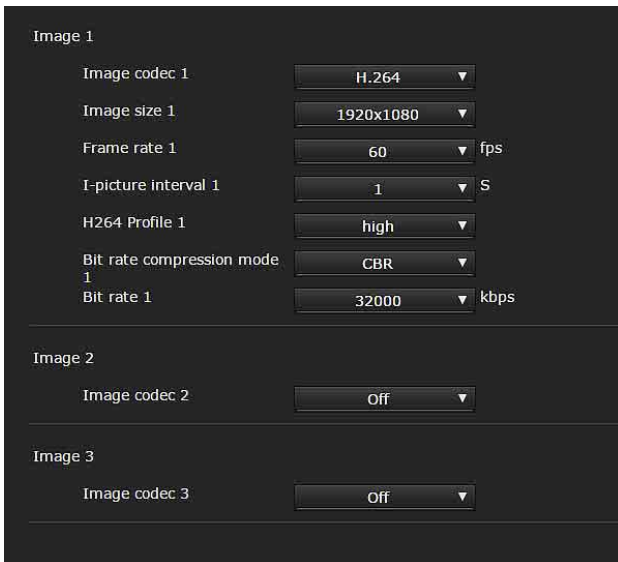

Use this tab to set the items for the video codec.

Image 1, Image 2 and Image 3

Up to three image codec modes can be set. Configure the following setting for each image mode.

Notes

- The frame rate and image size that can be selected may change, depending on the setting of the SDI video format.
- Video 2 and Video 3 are turned off when power is supplied via PoE+. No output is present.

Image codec

Choose **H.264** or **Off**. Video 1 cannot be turned off.

Notes

The selectable image size, frame rate, and image quality for Image 2 and Image 3 codecs may be limited depending on the setting of the image size and frame rate for Image 1.

If you set Image 2 or 3 to other than OFF, the bitrate cannot be set to a value over 8000kbps.

The following symptoms may occur depending on the combination of the image size, frame rate and bit rate for Image 1, 2 and 3.

In this case, adjust the value in each parameter to be low.

- The image delays more than usual.
- The frame is skipped when playing an image.
- The voice is broken.
- The response of the camera to commands delays.
- The response of the camera to operation from the remote controller delays.
- The moving speed of the Viewer and camera settings will be slow.

Image size

You can select the size of images sent from the camera.

Notes

- Some parts of the screen may not be displayed depending on the image size.
- If you use Images 1, 2, and 3, do not use Plug-in Free Viewer.

Frame rate

Set the frame rate of the image.

“fps” is a unit indicating the number of frames transmitted per second.

I-picture interval

Set the I-picture insertion interval in seconds.

H264 Profile

Set the profile setting for H.264 video codec to **high**, **main** or **baseline**. The video compression efficiency is **high**, **main** and **baseline** in sequence. The specified profile may not be available depending on the program you use. Select the profile which is suitable for your program.

Bit rate compression mode

Select **CBR** or **VBR**.

If you want to keep the bit rate fixed, select **CBR**. If you want to keep the image quality fixed, select **VBR**.

Note

The frame rate or bit rate that is actually transmitted may be different from the set values depending on image size, scene, network environment.

Bit rate

When the **Bit rate control** is set to **CBR**, you can set the bit rate for each line of image distribution. When the bit rate is set to a high level, a high image quality can be enjoyed.

Image quality

Image quality is enabled when **Bit rate compression mode** is set to **VBR**.

Selectable values are from **1** to **10**. When **10** is selected, the best image quality is achieved. Selectable values are changed depending on the setting.

Maximum bit rate limit

Enable the check box when **Bit rate compression mode** is set to **VBR**, to set the maximum value of the bit rate.

Max: Set the maximum value of the bit rate when the camera is operated with **VBR**.

Superimpose Tab

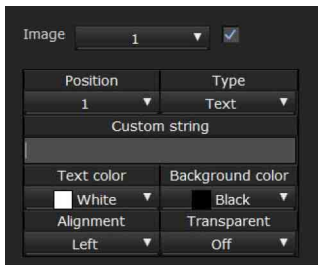

Select whether or not to superimpose the custom string on the image.

Three custom strings and one logo (still image) can be superimposed simultaneously.

Notes

- For setting the superimposing, set **Image size1** in the Video codec tab of the Video menu to the maximum rate.
- Deselect the checkbox of **Image stabilizer** in the Installation tab of the System menu. After setting superimpose, set the Image stabilizer function again.

Preview screen

Preview the image, and adjust the superimposed image. You can move the position of superimposed image displayed on the preview screen by drag and drop.

Image

Select the video codec mode to set for the superimposed image.

The setting for the superimposed image is available if you select the checkbox next to the list box.

For details about the video codec mode, see the Video codec tab in the Video menu.

Position

Select the number of the display position or logo, on the preview screen. When **Logo** is selected, the logo file setting is displayed.

Note

Permissible logo file specifications;
File format: PNG8 with alpha channel
Image size: 160 × 120 or smaller
Width (pixels): multiples of 16
You can cancel the logo files in the Initialize tab.

When display position number **1**, **2** or **3** is selected, the following setting menus appear.

Type

Sets codec, text, or zoom ratio for the display information type.

Codec: Displays the video codec information.

Text: Displays the custom string.

Zoom ratio: Displays the zoom ratio information.

Custom string

Describes the superimposed content for each position. <codeinfo> is displayed for codec and <zoomratio> for zoom rate, depending on the type. You can add an optional string around them.

Text color

Select the font color of the superimposed text.

Background color

Select the background color of the superimposed text.

Alignment

Set the horizontal position of the superimposed text.

Transparent

Select the background color transparent of the superimposed text. When you select **Off**, transparent is not available.

Day/Night ICR Tab

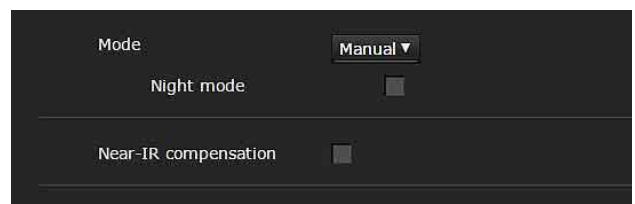

Use this tab to set the day/night ICR function of the camera.

Mode

Select the day/night ICR mode. This function has the following modes.

Auto

Normally works in day mode; switches automatically to night mode in a dark place.

Threshold

This mode is available when **Auto** is selected.
Set the brightness level when the day mode is set.

Note

When set to **Auto**, depending on the gain limit setting value in the Picture tab, the camera may switch to Night mode even when in bright surroundings. In this case, set the gain limit value to be high.

Manual

Switch the day/night ICR mode manually. When you select **Manual** and the checkbox of the Night mode is selected, the camera works in night mode. Otherwise, the camera works in day mode.

Near-IR compensation

Adjust background light when using the IR lamp or where there is much near short infrared ray. Select the checkbox to increase the accuracy of auto-focus in night mode.

Audio Menu

When you click **Audio** in the Administrator menu, the Audio menu appears.

Use this menu to set the audio functions of the camera. The Audio menu consists of the **Audio** tab.

Audio Tab

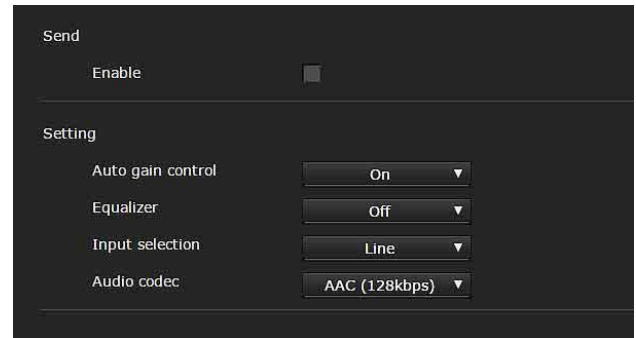

Send

Note

No audio is output if the Plug-in free viewer is used.

Enable

Select the checkbox if you want to send audio from the camera.

Note

Audio is available only when you retrieved the stream via RTSP.

Setting

Make settings for sending audio.

Auto gain control

Controls the audio input level to a suitable volume level automatically.

Equalizer

Uses to change the frequency response of audio in accordance with its use environment.

Off: Disable the equalizer setting.

Low cut: Reduces the noise from air conditioners and a projector, etc., and cuts low-frequency.

Voice enhancement: Enhances the voice clearly, cutting low- and high-frequency.

Input selection

Select microphone input or line input.

Audio codec

Select the codec type for sending audio.

AAC (128kbps): Select this type when you prioritize the audio quality.

AAC (64kbps): Select this type when you prioritize the data capacity.
This setting will not effect on the audio signal superimposed.

Network Menu

When you click **Network** in the Administrator menu, the Network menu appears.

Use this menu to configure the network to connect the camera and the computer.

The network menu is configured with the **Network** tabs.

Network Tab

Status		
MAC address	84:ab:19:5a:34:5e	
Ethernet status	1000M	
Auto-MDI/MDIX	MDI	
IP address	192.168.0.100	
Subnet mask	255.255.255.0	
Default gateway		
LinkLocal IP address		
Primary DNS server		
Secondary DNS server		
IPv6 address 1		
IPv6 address 2		
IPv6 default gateway		
IPv4 setting		
Obtain an IP address automatically (DHCP)	<input checked="" type="checkbox"/>	
Host name		
Domain suffix		
IPv6 setting		
Obtain IP address automatically	<input checked="" type="checkbox"/>	
Common setting		
HTTP port number	80	(80, 1024 to 65534)
MTU	1500	(1280 to 1500)
Obtain DNS server address automatically	<input checked="" type="checkbox"/>	

This section provides the menus for connecting the camera through the network cable.

Status

MAC address

Displays the MAC address of the camera.

Ethernet status

Displays the current transmission rate.

Auto-MDI/MDIX

According to the port of the connected Ethernet device, automatically switches the port of the unit between MDI and MDI-X for transmission.

Displays the Ethernet port mode of the unit.

IP address

Displays the current IP address.

Subnet mask

Displays the current subnet mask.

Default gateway

Displays the current default gateway.

LinkLocal IP address

Displays the current link-local IP address.

Primary DNS server

Displays the current primary DNS server.

Secondary DNS server

Displays the current secondary DNS server.

IPv6 address 1, 2

Displays the current IPv6 address.

IPv6 default gateway

Displays the current IPv6 default gateway.

IPv4 setting

Configure the IPv4 network setting.

To obtain the IP address automatically from a DHCP server

Select **Obtain an IP address automatically (DHCP)**.

The IP address, subnet mask, default gateway are assigned automatically.

Note

When you select **Obtain an IP address automatically (DHCP)**, make sure that a DHCP server is operating on the network.

Host name

Type the host name of the camera to be transmitted to the DHCP server. This setting is valid only when **Obtain an IP address automatically (DHCP)** is selected.

Domain suffix

Type the domain suffix of the camera to be transmitted to the DHCP server. This setting is valid only when **Obtain an IP address automatically (DHCP)** is selected.

Note

The domain suffix is sent to the DHCP server as FQDN (Fully Qualified Domain Name) information when **Host name** is set.

To specify the IP address manually

Deselect **Obtain an IP address automatically (DHCP)**. Type the address in the **IP address**, **Subnet mask** and **Default gateway** boxes. **Host name** and **Domain suffix** are not available.

IP address

Type the IP address of the camera.

Subnet mask

Type the subnet mask value.

Default gateway

Type the default gateway.

IPv6 setting

Configure the IPv6 network setting.

To obtain the IPv6 address automatically

Select **Obtain IP address automatically**.

The IP address, prefix length, default gateway are assigned automatically.

Note

If you select **Obtain IP address automatically**, ask the network administrator whether an IPv6 address can be assigned.

This function is not available in a multi-prefix environment. The transmission may not work properly.

To specify the IPv6 address manually

Deselect **Obtain IP address automatically**. Type the address in the **IP address**, **Prefix length** and **Default gateway** boxes.

IP address

Type the IP address of the camera.

Prefix length

Type the prefix length value.

Default gateway

Type the default gateway.

Common setting

Configure the common setting for IPv4 and IPv6 network.

HTTP port number

Type the HTTP port number. Normally select 80.

MTU

Type the MTU value for the Ethernet port.

To obtain DNS server address automatically

Select **Obtain DNS server address automatically**. The **Primary DNS server** and **Secondary DNS server** are assigned automatically.

Note

To obtain a DNS server address automatically, first enable **Obtain an IP address automatically (DHCP)** in the IPv4 setting, or **Obtain IP address automatically** in the IPv6 setting.

Ask the network administrator whether a DNS server address can be obtained automatically.

To specify the DNS server address manually

Deselect **Obtain DNS server address automatically**. Type the address in the **Primary DNS server** and **Secondary DNS server** boxes.

Primary DNS server

Type the IP address of the primary DNS server.

Secondary DNS server

Type the IP address of the secondary DNS server, if necessary.

Security Menu

When you click **Security** in the Administrator menu, the Security menu appears.

The security menu consists of the **User**, **Access limit**, and **Referer check** tabs.

Administrator and User

This camera identifies those who log in as the **Administrator** or **User**.

The **Administrator** can use all the functions of this camera, including camera settings. The **User** can use functions for monitoring the image from the camera and control the camera. The **Viewer mode** setting is used to restrict the user's access rights. There are five types of users.

Each type of user can use the corresponding functions below.

Function	Administrator	User			
		Full	Pan/Tilt	Light	View
Monitor a live image	●	●	●	●	●
Control the frame rate	●	●	●	●	—
Control the image view size	●	●	●	●	—
Perform the pan/tilt/zoom operation	●	●	●	—	—
Control the setting menu	●	—	—	—	—

- Usable function
- Not usable function

User Tab

Set the user names and passwords of Administrator and up to 9 types of user (User 1 to User 9), and the viewer mode of each user.

Administrator, User 1 to 9

Specify **User name**, **Password**, **Re-type password** and **Viewer mode** for each user ID.

User name

Type a user name between 5 and 16 characters.

Password

Type a password between 8 and 16 characters.

Note

The password entered must be a combination of numbers and alphabets.

Re-type password

To confirm the password, retype the password that you typed in the **Password** box.

Viewer mode

When the user is authenticated for logging in the viewer, select the viewer mode to be displayed after authentication.

Administrator: The user can operate all functions including the setting menu in this mode.

Full: The user can operate all functions other than the setting menu.

Pan/Tilt: In addition to the **Light** mode, the user can operate pan/tilt/zoom.

Light: In addition to the **View** mode, the user can select the image size of the live viewer, select codec and capture a still image.

View: The user can only monitor the camera image.

Viewer authentication

Set whether the user is authenticated or not when the viewer is displayed.

When the checkbox is selected, the viewer is displayed in accordance with the viewer mode of the authenticated user. When the checkbox is not selected, select the viewer

mode of the viewer which is displayed without authentication from **Full**, **Pan/Tilt**, **Light** or **View**.

Authentication mode

Set the authentication method for user authentication.

Basic authentication: Use the basic access authentication.

Digest authentication: Use the digest access authentication.

Note

If you change the settings in **Authentication mode**, close the web browser and access again.

Access limit Tab

Enable	<input checked="" type="checkbox"/>
Default policy	Allow
Network address/Subnet 1	192.168.0.1 8 (8 to 32) Allow
Network address/Subnet 2	(8 to 128) Allow
Network address/Subnet 3	(8 to 128) Allow
Network address/Subnet 4	(8 to 128) Allow
Network address/Subnet 5	(8 to 128) Allow
Network address/Subnet 6	(8 to 128) Allow
Network address/Subnet 7	(8 to 128) Allow
Network address/Subnet 8	(8 to 128) Allow
Network address/Subnet 9	(8 to 128) Allow
Network address/Subnet 10	(8 to 128) Allow

This allows you to control which computers can have access to the camera.

Likewise, when using IPv6, security settings can be configured for each network.

Enable

Select the checkbox to enable the access limit.

Default policy

Select the basic policy of the limit from **Allow** and **Deny** for the computers that are not specified in the Network address/Subnet 1 to Network address/Subnet 10 menus below.

Network address/Subnet 1 to Network address/Subnet 10

Type the network addresses and subnet mask values that you want to allow or deny access to the camera.

You can specify up to 10 network addresses and subnet mask values. For a subnet mask, type 8 to 32.

(In the case of IPv6, enter a value between 8 and 128.)

Select **Allow** or **Deny** from the drop-down list on the right for each network address/subnet mask.

Note

The subnet mask value represents the bit number from the left of the network address.

For example, the subnet mask value for “255.255.255.0” is 24.

If you set **192.168.0.0/24** and **Allow**, you can allow access from computers having an IP address between “192.168.0.0” and “192.168.0.255”.

Note

You can access the camera even from a computer with an IP address whose access right is set to **Deny**, if you enter the user name and password set for the Administrator in the User tab of the Security menu in the authentication screen.

Referer check Tab

Referer check	<input checked="" type="checkbox"/>
Exception list	No. Host name Port number
	1 80 80
	2 80
	3 80
	4 80
	5 80
	6 80
	7 80
	8 80
	9 80
	10 80

Referer check checks if the web page which requires access is authorized when the camera is accessed. If the web page is not authorized, the camera denies access of the web page to the camera.

If you want to access from web pages other than the one that the camera provides, register their host names and port numbers in the **Exception list**.

Referer check

Select the checkbox for the **Referer check**.

Exception list

Register the hosts that are not targeted for the **Referer check**.

No.

Select the registered numbers of the **Exception list**.

Host name

Type the host name or IP address of the PC that supplies the web page you want to register on the **Exception list**.

Port number

Type the host name or the port number of the PC that supplies the web page you want to register on the

Exception list.

Set

Register the values of the **Host name** and **Port number** you typed to the list of the selected number.

Delete

Delete the contents of the list selected in **No.**

PTZF control Menu

When you click **PTZF control** in the Administrator menu, the PTZF control menu appears.

The PTZF operation menu is configured with the **PTZF operation**, **Preset positions** tabs.

PTZF control Tab

You can also set from the remote controller. See “PAN TILT ZOOM Menu” on page 44.

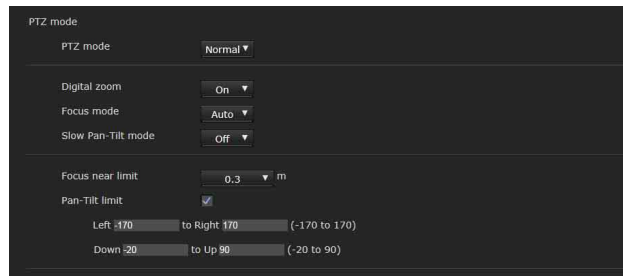

PTZ mode

Set the pan/tilt control mode using the 8-direction arrow buttons (page 48) and the zoom control mode using the **W**/**T** buttons (page 48). Select **Normal** or **Step**.

Normal: When you click the mouse button, the camera starts panning, tilting or zooming, and the operation continues while you hold down the mouse button. To stop the operation, release the mouse button.

Step: Each time you click the mouse button, the camera moves (pans, tilts or zooms). If you keep the mouse button held down for more than 1 second, the operation mode is temporarily changed to **Normal**.

When you release the mouse button, camera operation stops and the **Step** mode is restored.

When you select **Step**, **Pan/Tilt level** and **Zoom level** are selectable.

Pan/Tilt level: Select the camera transition level from **1** to **10** by clicking the 8-direction arrow buttons for panning/tilting. Selecting **10** provides the maximum transition level.

Zoom level: Select the camera transition level from **1** to **10** by clicking **W**/**T** for zooming. Selecting **10** provides the maximum transition level.

Digital zoom

Select On/Off of the digital zoom.



On: An image can be zoomed up to 30× optical zoom and 12× digital zoom, 360× zoom in total.

Off: An image can be zoomed up to 30× optical zoom.

Focus mode

Select the focus mode.

Auto: The focus is automatically adjusted.

Manual: The focus can be adjusted by using the ,  and **One Push Focus** buttons of the control panel displayed in the main viewer.

Slow Pan-Tilt mode

When set to **Slow Pan-Tilt mode** for the panning/tilting, select **On**.

Focus near limit

Set the range at which to automatically focus. If a subject is nearer than the set range, it will not be focused.

Pan-Tilt limit

When you check the checkbox, it limits the panning/tilting range. You can select the following values:

Left: -170° to 169° , selectable in 1° steps.

Right: -169° to 170° , selectable in 1° steps.

Up: -29° to 90° (Eflip: OFF)

-89° to 30° (Eflip: ON), selectable in 1° steps.

Down: -30° to 89° (Eflip: OFF)

-90° to 29° (Eflip: ON), selectable in 1° steps.

Note

When switching the Eflip function On/Off, the setting is returned to the factory setting. Set the Eflip function setting in accordance with the installation condition of the camera and select the value.

Setting the range of the UP/DOWN movement

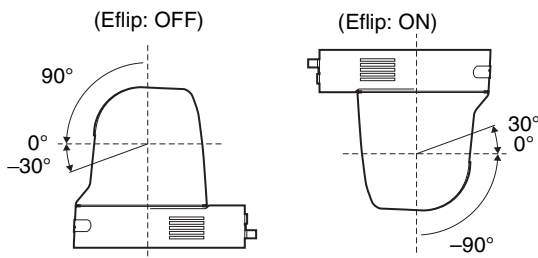

Preset position Tab

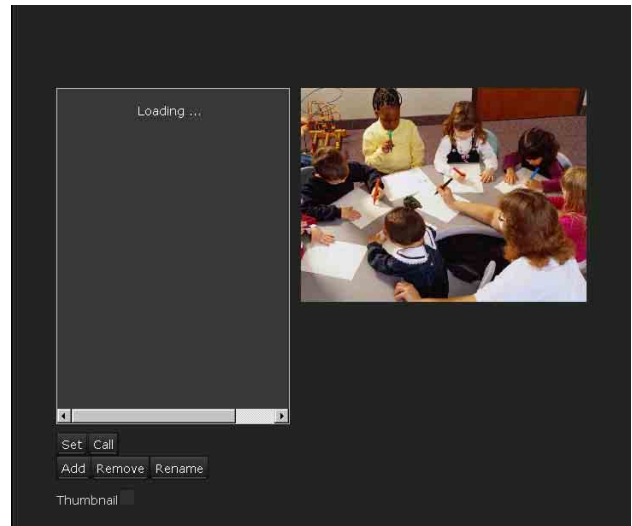

You can set up camera pan, tilt, and zoom positions to 256 positions. You can also store the camera settings in the preset positions from 1 to 16 through operation from the remote controller. For details, see “Operation Using the Remote Controller” - “Presetting Feature” on page 37. Preset reserves the camera settings. For details of the camera settings to be preset, see “Initial value and preset” on page 71.

Note

If the camera settings are not stored in Preset 1, the camera settings are cleared from the memory and reset to the default settings when the power is turned on. For the setting items and actions that are retained in the memory, “Initial value and preset” on page 71.

Preview screen

This screen is for monitoring images and setting preset.

Set

Click to save a selected position, such as pan, tilt or zoom positions in the preset. You can also store the camera settings in the preset positions from 1 to 16. For the setting items that can be stored, see “Initial value and preset” on page 71.

Call

Move to the pan, tilt and zoom positions saved in the selected preset. You can also call the stored camera settings from the preset positions 1 to 16. Depending on where to read out, pan/tilt and zoom don't sync.

Add

Save the current pan, tilt and zoom positions as a new preset. You can also store the camera settings in the preset positions from 1 to 16. For the setting items that can be stored, see “Initial value and preset” on page 71.

Remove

Delete the selected preset items and return the stored settings to the factory settings. For the setting items stored in each preset setting, see “Initial value and preset” on page 71.

Rename

Change the name of a selected preset.

Thumbnail

Check this checkbox to registers a thumbnail. Select a radio button to determine whether to register the current camera image as a thumbnail or to register with a specified image. To specify an image, click **Choose File**.

Note

A thumbnail cannot be registered with the operation using the remote controller. When switching the Eflip function On/Off in the Installation tab of System menu, all preset settings are deleted.

Streaming Menu

When you click **Streaming** in the Administrator menu, the Streaming menu appears.

Use this menu to set the items for the transmission by unicast or multicast.

The Streaming menu consists of the **Streaming** tab.

Streaming Tab

Unicast streaming

RTSP video port number 1 51000 (1024 to 65534)

RTSP video port number 2 53000 (1024 to 65534)

RTSP video port number 3 55000 (1024 to 65534)

RTSP audio port number 57000 (1024 to 65534)

Multicast streaming

Enable

RTSP multicast address 239.192.0.200

RTSP multicast video port number 1 61000 (1024 to 65534)

RTSP multicast video port number 2 63000 (1024 to 65534)

RTSP multicast video port number 3 65000 (1024 to 65534)

RTSP multicast audio port number 59000 (1024 to 65534)

RTSP setting

RTSP port number 554 (554, 1024 to 65534)

RTSP time out 0 (0 to 600)

Unicast streaming

Specify the transmission port numbers of the H.264 video data and audio data to be used when **Unicast** is selected from the **Connection** drop-down list in the **Other** panel on the live viewer.

Note

Specify different numbers for the video port number and the audio port number.

RTSP video port number 1, 2, 3

Specify the H.264 video transmission port number used for RTSP unicast streaming. The default setting is 51000, 53000 or 55000. Specify an even number from 1024 to 65534. Two port numbers (the number specified here and an odd number with 1 added to the specified number) are actually used for video data communication and control. When performing simultaneous multi-transmission, a different port number will be used for every transmission, based on the port number specified here. The settings for Image 1, Image 2 and Image 3 apply to RTSP video port number 1, 2 and 3 respectively.

RTSP audio port number

Specify the audio transmission port number used for RTSP unicast streaming. The default setting is 57000. Specify an even number from 1024 to 65534. Two port numbers (the number specified here and an odd number with 1 added to the specified number) are actually used for audio data communication and control. When performing simultaneous multi-transmission, a different

port number will be used for every transmission, based on the port number specified here.

Multicast streaming

Set whether the camera uses multicast streaming for H.264 video data and audio data or not. It reduces the transmission load on the camera by having a computer of the same segment network receive the same transmitting data.

Enable

Select the checkbox to allow multicast sending.

When you select the checkbox, set **Multicast address**, **Video port number** and **Audio port number** properly.

Note

Specify different numbers for the video port number and the audio port number.

RTSP multicast address

Set the multicast address used on RTSP multicast streaming.

RTSP multicast video port number 1, 2, 3

Specify the H.264 video transmission port number used for RTSP multicast streaming. The default setting is 61000, 63000 or 65000. Specify an even number from 1024 to 65534. Two port numbers (the number specified here and an odd number with 1 added to the specified number) are actually used for video data communication and control.

The settings for Image 1, Image 2 and Image 3 apply to Video port number 1, 2 and 3 respectively.

RTSP multicast audio port number

Specify the audio transmission port number used for RTSP multicast streaming. The default setting is 59000. Specify an even number from 1024 to 65534. Two port numbers (the number specified here and an odd number with 1 added to the specified number) are actually used for audio data communication and control.

RTSP setting

Set the RTSP setting which cannot be set in the Unicast streaming setting and Multicast streaming.

RTSP port number

Set the port number used for RTSP streaming. The default setting is 554.

If you change the setting, the RTSP server will be rebooted.

RTSP time out

Specify the time out of the Keep-Alive command by RTSP streaming. You can set the time out from **0** second to **600** seconds.

At the **0** setting, time out of the Keep-Alive command is not available.

Message List

The following messages and indications may appear for this camera. Perform the following as necessary.

Lamp display

Lamp	Meaning and solution
POWER and NETWORK lights flash simultaneously.	A hardware failure (internal temperature abnormal or FAN motor faulty) is detected. Check if the FAN motor is running.

Troubleshooting

Before bringing in your camera for servicing, check the following as a guide for troubleshooting the problem. If the problem cannot be corrected, consult your Sony Service Center.

Symptom	Cause	Remedy
The power of the camera is not turned on.	The AC power adaptor is not connected to the DC 12 V connector firmly.	Insert the power cord firmly as far as it will go.
	The AC power cord is not inserted firmly into the AC power adaptor or the AC outlet.	Insert the power cord firmly as far as it will go.
	PoE+ power supply device is not working properly.	Check the connection between the PoE+ power supply and the unit. Or, replace the connection cable or the power supply device.
The picture is not displayed on the video monitor connected to the camera.	The video cable is not connected properly.	Check the connection between the camera and video monitor.
	The exposure is not set correctly on the camera.	Set the exposure correctly on the EXPOSURE menu (page 24).
	The SYSTEM SELECT switch on the rear of the camera is not set correctly.	Check the selected output signal format of the camera and the input signal format of the connected monitor.
Pan, tilt, or zoom cannot be operated.	A menu is displayed on the monitor screen.	Press the DATA SCREEN button on the supplied infrared remote commander to remove the menu from the monitor screen.
	The panning or tilting range is limited.	Change the pan/tilt limit settings on the PAN TILT ZOOM menu (page 27).
The infrared remote commander does not work.	The CAMERA SELECT button you pressed on the infrared remote commander does not match the number set with the IR SELECT switch on the camera.	Press the CAMERA SELECT button corresponding to the IR SELECT switch setting on the camera (page 10).
The VISCA CONTROL is not available with a computer connected to the camera.	The computer is not correctly connected to the camera.	Make sure the connection between the computer and camera is made correctly.
LAN communication is not available with a computer connected to the camera.	The computer is not correctly connected to the camera.	Make sure the connection between the computer and camera is made correctly.
	The computer is not correctly set.	Check the precautions in the setting of the dedicated PC application.
The camera does not work when connected one-to-one to the IP remote controller.	A crossover cable is not used.	Use a crossover cable for one-to-one LAN connection.
All actions are performed but the symptom remains.	—	Pull out the plug of the power cord from the AC outlet, then reinsert it into the AC outlet after waiting a while.

Menu Configuration

The menus of the camera are configured as described below. For more details, refer to the pages in parentheses. The initial settings of each item are in bold.

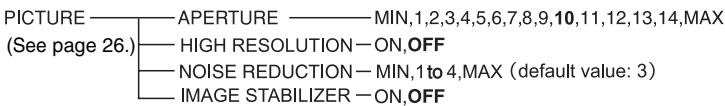
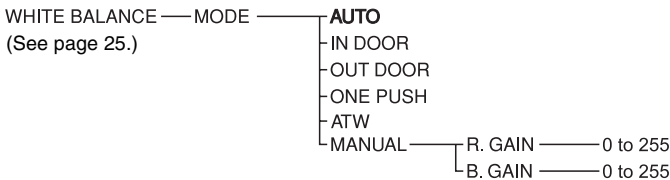
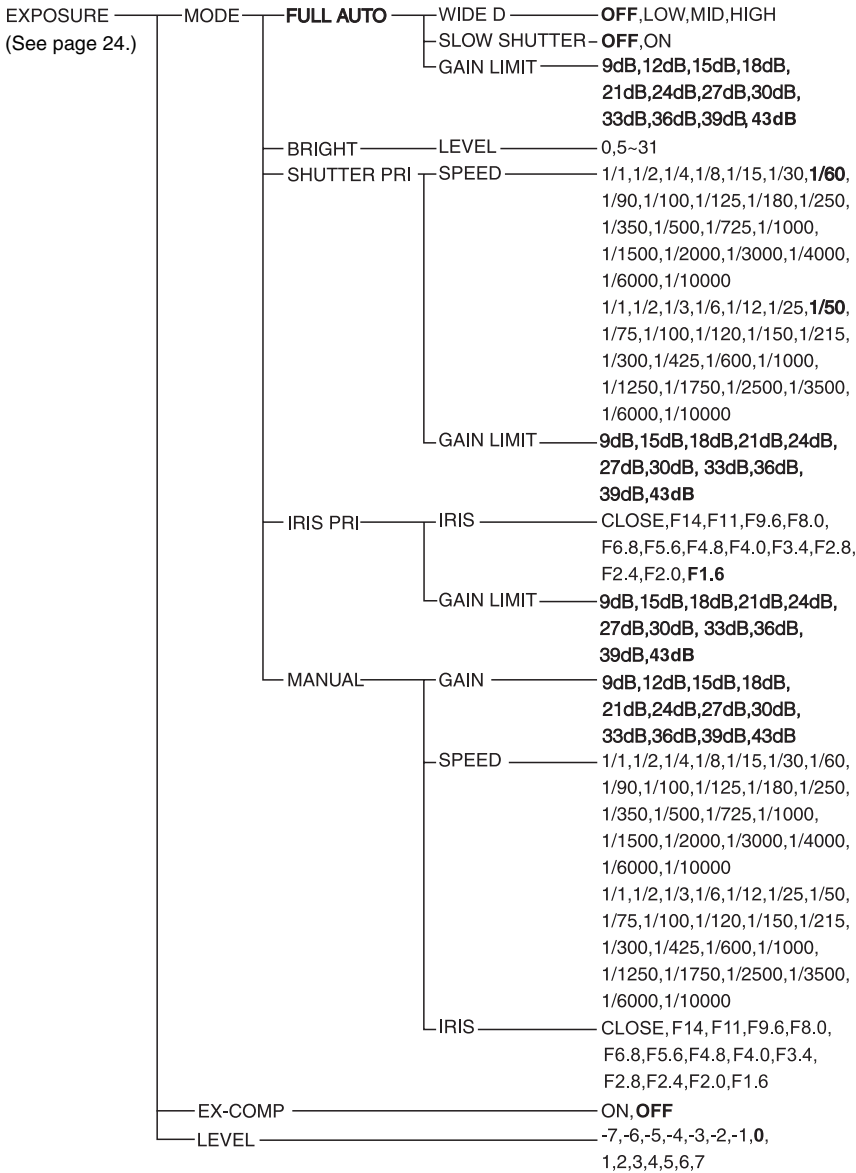
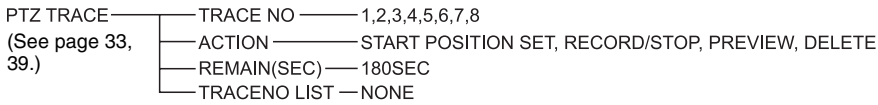

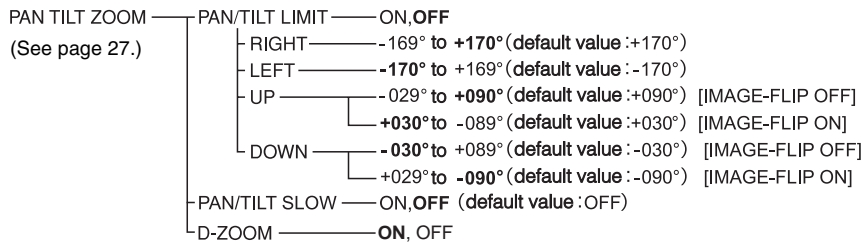

SYSTEM (See page 28.) — MAINTENANCE

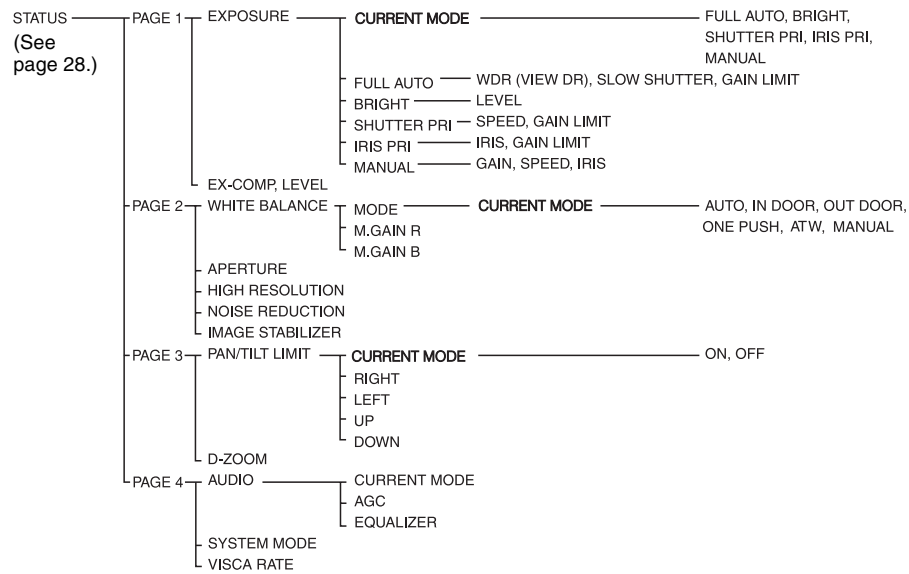

Initial value and preset

- The initial values are the factory settings.
- When the power is turned on, this unit starts operation with the settings stored in preset 1.
- In “Preset 1 to 256”, the items that are preserved even after the power from the camera is turned off are indicated by a circle (○), and the items that are not preserved are indicated by a cross (×).

Mode/Position setting	Initial settings	Preset 1	Presets 2 to 256
Pan/Tilt Position	Home position	○	○
Pan/Tilt Limit Position	Maximum range of movement	○	×
Zoom Position	Wide end	○	○
D-Zoom On/Off	On	○	○
Focus Position	—	○	○
Focus Auto/Manual	Auto	○	○
Near Limit settings	D000h (30 cm)	○	×
AF Sensitivity	Normal	○	×
AF Mode	Normal	○	×
AF Run Time	5 sec	○	×
AF Interval	5 sec	○	×
WB Mode	Auto	○	○
WB Data (Rgain, Bgain)	—	○	○
One Push WB Data	—	○	×
AE Mode	Full Auto	○	○
WD Mode	Off	○	○
Auto Slow Shutter Mode	Off	○	○
Shutter Position	—	○	○
Iris Position	—	○	○
Gain Position	—	○	○
Bright Position	—	○	○
Exposure Compensation On/Off	Off	○	○
Exposure Compensation Amount	±0	○	○
BackLight On/Off	Off	○	○
Aperture Level	0Ah	○	○
High Resolution Mode On/Off	Off	○	×
Picture Effect	Off	○	×
ICR On/Off	Off	○	○
Auto ICR On/Off	Off	○	×
Auto ICR Threshold Level	0Eh	○	×
Image Stabilizer On/Off	Off	○	×
High Sensitivity Mode On/Off	Off	○	×
Gamma	0:standard	○	×
Defog On/Off	Off	○	○
NR level	3	○	×
Gain Limit	—	○	×
Low-Illumination Chroma Suppress	2h (Middle)	○	×
Color Gain	4h (100%)	○	×
Color Hue	7h (0 degree)	○	×

Notes

- When turning the power off and on again, if you want to reflect the camera conditions and pan/tilt position that are set before the power is turned off, store the settings in POSITION1.
- The setting or deleting of memory to/from preset 1 takes approx. 2 seconds longer than other channels.
- When ImageFlip is executed, all presets are reset to the initial value.
- CAM_Memory command is effective only for PRESET 1 through 16.

Specifications

System

Video signal	1920 × 1080p/59.94(A) 1920 × 1080p/59.94(B) 1920 × 1080p/29.97 1920 × 1080i/59.94 1280 × 720p/59.94 1280 × 720p/29.97 1920 × 1080p/50(A) 1920 × 1080p/50(B) 1920 × 1080p/25 1920 × 1080i/50 1280 × 720p/50 1280 × 720p/25
Web UI	(switched with the SYSTEM SELECT switch)
Synchronization	Internal synchronization
Image device	1/2.8 type Exmor CMOS
Lens	30× (optical), 12× (digital) f = 4.3 mm (wide) to 129 mm (tele) F1.6 to 4.7 Horizontal angle: 65 degrees (WIDE end)
Minimum object distance	10 mm ($13/32$ inches) (WIDE end) to 1200 mm (47 $1/4$ inches) (TELE end)
Minimum illumination	1.4 lux (F1.6, 50 IRE, high-sensitivity mode OFF, 30fps) 2.8 lux (F1.6, 50 IRE, high-sensitivity mode OFF, 60fps) 0.35 lux (F1.6, 50 IRE, high-sensitivity mode ON, 30fps) 0.7 lux (F1.6, 50 IRE, high-sensitivity mode ON, 60fps)
Shutter speed	1/1 to 1/10000 sec. (22 steps)
Video S/N	50 dB
Pan/tilt action	Horizontal: ±170 degrees Maximum panning speed: 60 degrees/sec. Vertical: +90, -30 degrees (IMAGE FLIP: OFF) +30, -90 degrees (IMAGE FLIP: ON) Maximum tilting speed: 60 degrees/sec.

Input/output connectors

HDMI OUT connector	(HDMI connector)
VISCA RS-422 connector	RJ-45
Power connector	JEITA type4 (DC 12 V)
SDI OUT connector	BNC connector
LAN connector	RJ-45 (IEEE802.3at compatible)

MIC input connector	Mini jack (x2)
USB connector	USB connector (for maintenance)

General

Input voltage	DC 12 V (AC adaptor 100 to 240 V, 50/60Hz) PoE+ (IEEE802.3at compatible)
Power consumption	25.5 W
Operating temperature	0 °C to +40 °C (+32 °F to +104 °F)
Storage temperature	-20 °C to +60 °C (-4 °F to +140 °F)
Dimensions	Video camera: 159 × 187.5 × 200.5 mm (6 $3/8$ × 7 $1/2$ × 8 inches) (w/h/d) (Projection is not included) Infrared Remote Commander: 56 × 26 × 210 mm (2 $1/4$ × 1 $1/16$ × 8 $3/8$ inches) (w/h/d)
Installation angle	Less than ±15 degrees to the horizontal surface

Supplied accessories

AC power adaptor (1)
AC power cord (1)
Infrared Remote Commander (1)
Ceiling bracket (A) (1)
Ceiling bracket (B) (1)
Wire rope (1)
Screw M3 × 8 (9)
Screw M2.6 × 6 BLACK (1)
HDMI cable fixing plate (1)
Safety Regulations (1)
Operating Instructions - Download site information (1)
Warranty (1)

Design and specifications are subject to change without notice.

Dimensions

Top

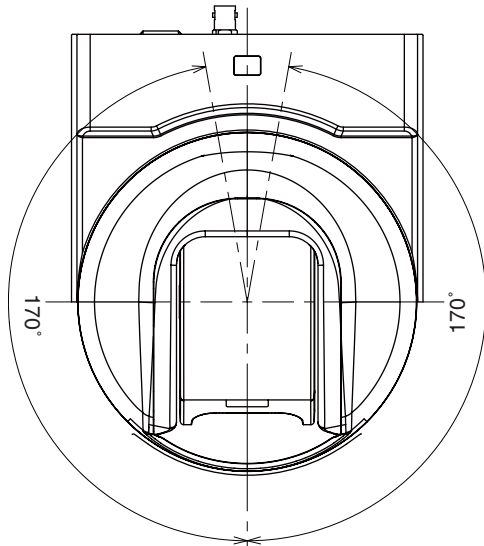

Back

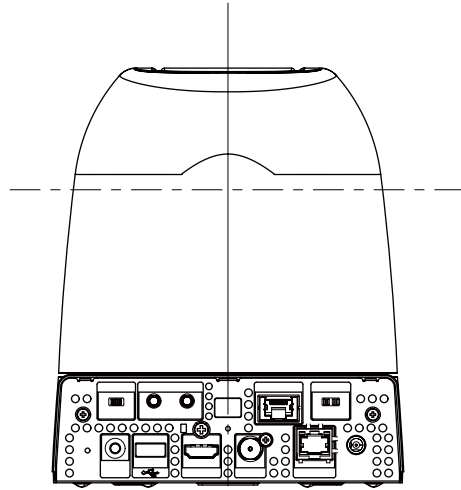

Front

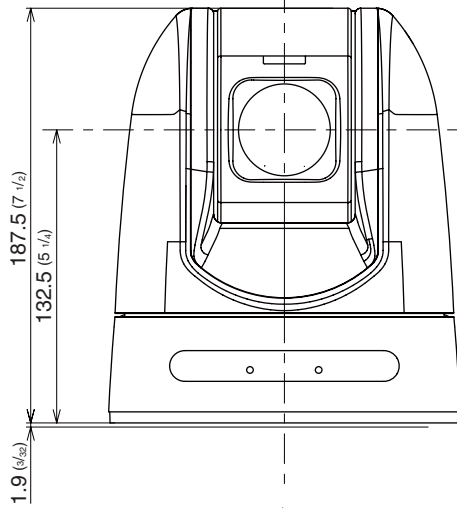

Side

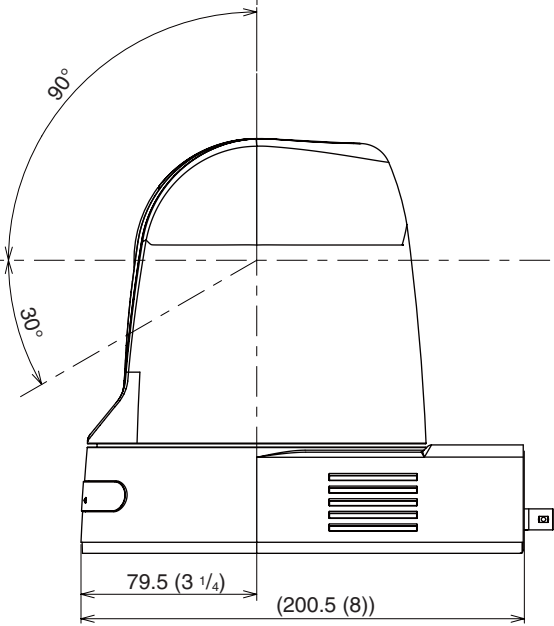

Bottom

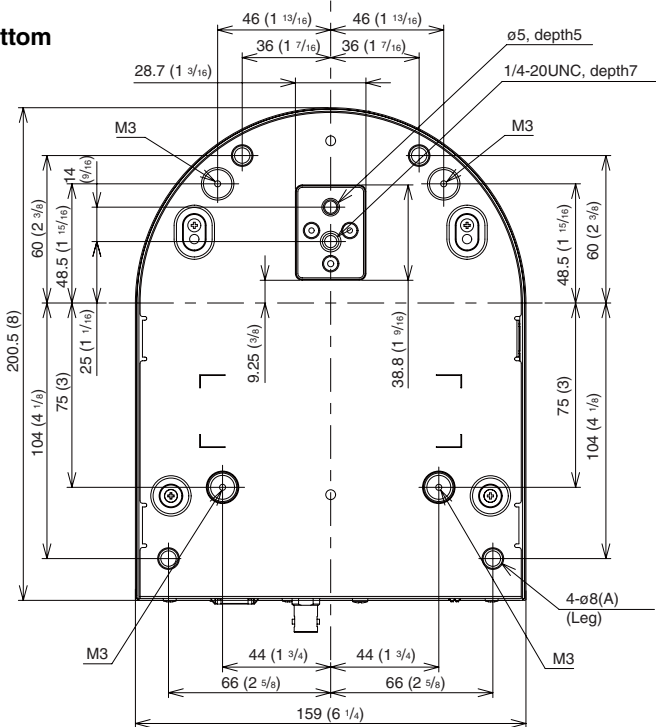

Ceiling bracket (B)

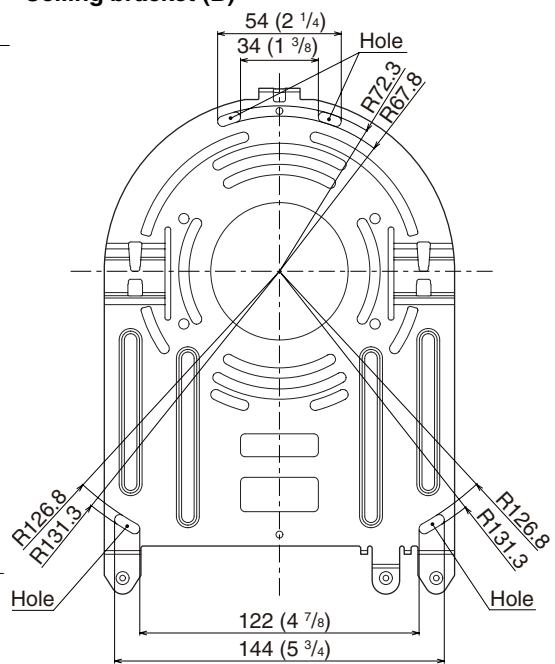

Unit: mm (inches)

Using the VISCA RS-422 connector pin assignments

The VISCA RS-422 connector pin assignments



Pin No.	Function
1	TX -
2	TX +
3	RX -
4	GND
5	GND
6	RX +
7	
8	

Connection diagram of a Remote Control unit (RM-IP10)

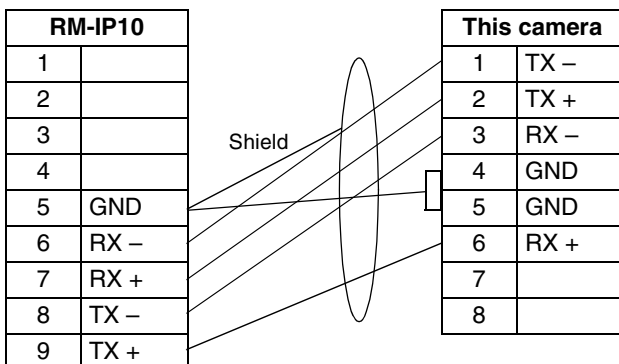

Notes

- In order to stabilize the voltage level of the signal, connect both ends to GND.
- For the network cable, use a cable that is category 5e or higher and is equivalent or higher than a shield twist pair.

<http://www.sony.net/>

Sony Corporation