

## LIMITED WARRANTY

The Little Tikes Company makes fun, high quality toys. We warrant to the original purchaser that this product is free of defects in materials or workmanship for one year\* from the date of purchase (dated sales receipt is required for proof of purchase). At the sole election of The Little Tikes Company, the only remedies available under this warranty will be the replacement of the defective part or replacement of the product. This warranty is valid only if the product has been assembled and maintained per the instructions. This warranty does not cover abuse, accident, cosmetic issues such as fading or scratches from normal wear, or any other cause not arising from defects in material and workmanship. \*The warranty period is three (3) months for daycare or commercial purchasers.

U.S.A and Canada: For warranty service or replacement part information, please visit our website at [www.littletikes.com](http://www.littletikes.com), call 1-800-321-0183 or write to: Consumer Service, The Little Tikes Company, 2180 Barlow Road, Hudson OH 44236, U.S.A. Some replacement parts may be available for purchase after warranty expires—contact us for details.

Outside U.S.A and Canada: Contact place of purchase for warranty service. This warranty gives you specific legal rights, and you may also have other rights, which vary from country/state to country/state. Some countries/states do not allow the exclusion or limitation of incidental or consequential damages, so the above limitation or exclusion may not apply to you.

## BATTERY SAFETY INFORMATION

- Charging of rechargeable batteries should only be done under adult supervision. Use only size "AA" (LR6) alkaline batteries (3 required).
- Never mix old batteries with new batteries, rechargeable (nickel-cadmium) or carbon zinc with alkaline batteries.
- Be sure to insert the batteries correctly and follow the toy and battery manufacturer's instruction.
- Always remove exhausted or dead batteries from the product.
- Dispose of dead batteries properly: do not burn or bury them.
- Do not attempt to recharge non-rechargeable batteries.
- Remove rechargeable batteries from the product before recharging.
- Charging of rechargeable batteries should only be done under adult supervision with batteries removed from product.
- Avoid short-circuiting battery terminals.
- Remove batteries before placing the unit into storage for a prolonged period of time.

## FCC COMPLIANCE

NOTE: This equipment has been tested and found to comply with the limits for a Class B digital device, pursuant to Part 15 of the FCC Rules. These limits are designed to provide reasonable protection against harmful interference in a residential installation. This equipment generates, uses and can radiate radio frequency energy and, if not installed and used in accordance with the instructions, may cause harmful interference to radio communications. However, there is no guarantee that interference will not occur in a particular installation. If this equipment does cause harmful interference to radio or television reception, which can be determined by turning the equipment off and on, the user is encouraged to try to correct the interference by one or more of the following measures:

- Reorient or relocate the receiving antenna.
- Increase the separation between the equipment and receiver.
- Connect the equipment into an outlet on a circuit different from that to which the receiver is connected.
- Consult the dealer or an experienced radio/TV technician for help.

This device complies with Part 15 of the FCC Rules. Operation is subject to the following two conditions: (1) This device may not cause harmful interference, and (2) this device must accept any interference received, including interference that may cause undesired operation.

Caution: Modifications not authorized by the manufacturer may void users authority to operate this device. CAN ICES-3 (B)/NMB-3(B).



Let's care for the environment!  
The wheelee bin symbol indicates that the product must not be disposed of with other household waste. Please use designated collection points or recycling facilities when disposing of the item.  
Do not treat old batteries as household waste. Take them to a designated recycling facility.

Please keep this manual as it contains important information.



© The Little Tikes Company, an MGA Entertainment company. LITTLE TIKES® is a trademark of Little Tikes in the U.S. and other countries. All logos, names, characters, likenesses, images, slogans, and packaging appearance are the property of Little Tikes.  
Little Tikes Consumer Service  
2180 Barlow Road  
Hudson, Ohio 44236 U.S.A.  
1-800-321-0183  
Printed in China

MGA Entertainment UK Ltd.  
50 Presley Way  
Crownhill  
Milton Keynes  
MK8 0ES  
Bucks, UK  
0800 521 558



Visit our website at  
[www.littletikes.com](http://www.littletikes.com)  
to register your product  
online!

[www.littletikes.com](http://www.littletikes.com)  
[www.littletikes.co.uk](http://www.littletikes.co.uk)

little tikes®

Little Tikes®  
Big Dog Truck™

ENG

635762C

AGES 1-3 YEARS  
ADULT BATTERY INSTALLATION AND ASSEMBLY REQUIRED

## CONTENTS

- A. 1 Big Dog Truck    B. 3 Boulders    C. 1 Smoke Stack    D. 4 Wheels

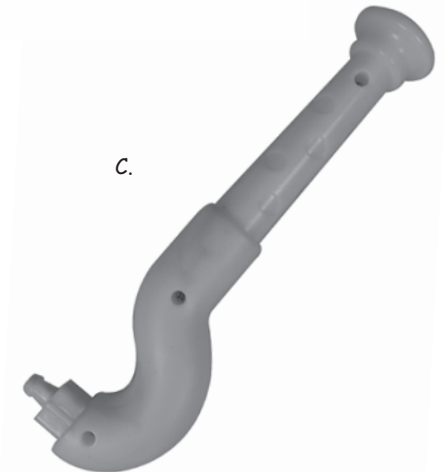

Illustrations are for reference only. Styles may vary from actual contents.

## ASSEMBLY

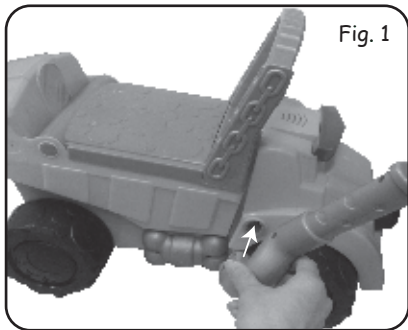

Fig. 1

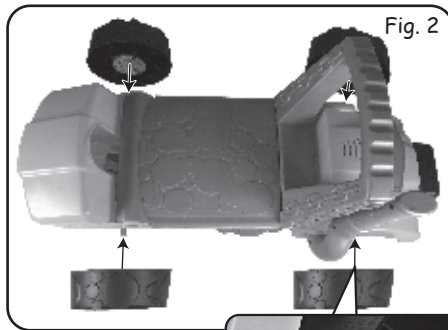
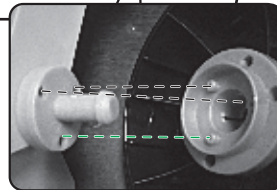

Fig. 2



1. Press the smoke stack into the opening on the vehicle body until it snaps into place. (Fig. 1)
2. Snap the wheels onto the sides of the vehicle by aligning the openings on the wheel with the pegs on the vehicle body. (Fig. 2)

## BEFORE YOU BEGIN

1. Using a Phillips screwdriver (not included) remove the screw and battery compartment cover from the bottom of the Truck. (Fig.3)
2. Install three (3) 1.5V AA alkaline batteries (not included) making sure the (+) and (-) ends face the proper direction as indicated inside the battery compartment. (Fig. 3)
3. Replace the compartment cover and tighten the screw.

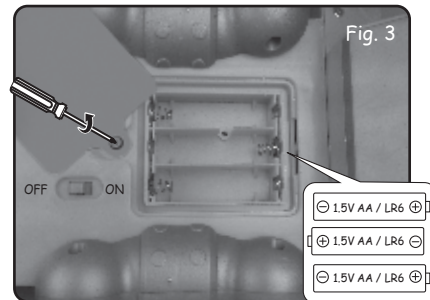

Fig. 3

## HOW TO PLAY

1. To turn on the Big Dog Truck™, move the switch by the battery compartment to the "ON" position.
2. Place the Boulders on the floor.
3. Ride the Big Dog Truck™ or push it over the Boulders to watch the dog eat them up and make sounds. (Fig. 4)
4. Push the Smoke Stack forward (Fig. 5) to release the boulders from the back of the Big Dog Truck™.
5. The truck will make dog noises as the boulders are dumped! (Fig. 6)
6. The truck's nose will make sounds and the light bar will activate when it is pressed or bumped!
7. Move the ON/OFF switch to "OFF" when the Big Dog Truck™ is not in use.

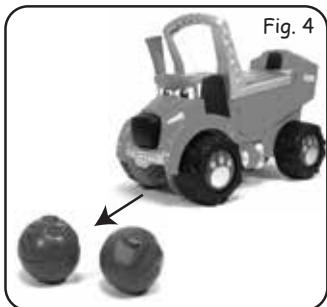

Fig. 4

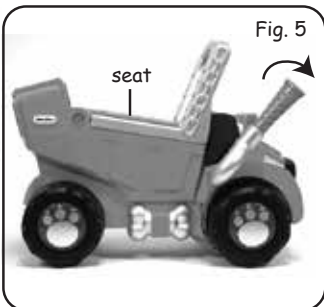

Fig. 5

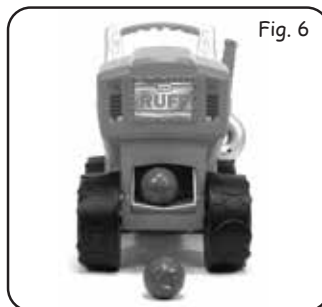

Fig. 6

## OTHER USES

1. Turn the dial on the handle hinge until the arrows are aligned as shown. This will lock the handle so that the child can safely push the truck as a walker. (Fig. 7)
2. Turn the dial on the handle hinge so the arrow faces upward to unlock the handle as shown. The seat will open and close freely and the unit can be pulled along as a wagon. (Fig. 8)
3. Lift open the seat to store Boulders when not in use. (Fig. 9)

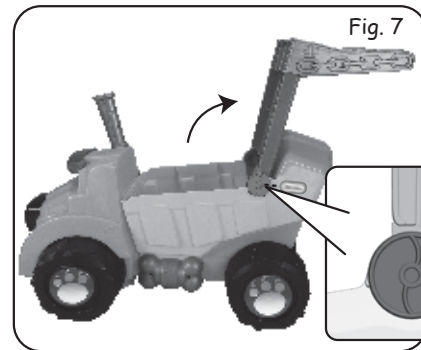

Fig. 7

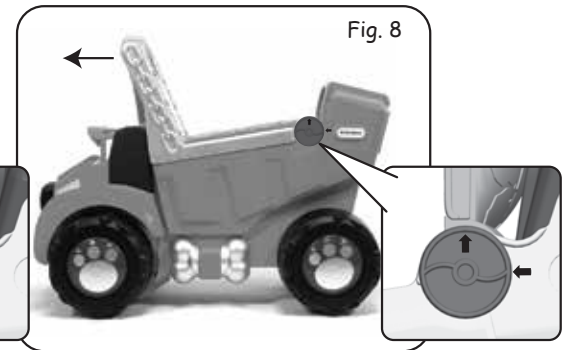

Fig. 8



Fig. 9

## ⚠️ WARNING:

### ADULT ASSEMBLY REQUIRED.

- Keep away from children until assembled.
- Constant, competent adult supervision is required when child is riding the Truck.
- DO NOT stick fingers or other objects into the rotating device that picks up the Boulders.
- DO NOT attempt to pick up any objects other than the included Boulders.
- Keep long hair away from unit when riding and/ or picking up Boulders.
- Use the Big Dog Truck™ in an open space away from furniture, pets, etc.
- Ride-on toys should not be used near swimming pools, on or near steps, hills, roadways, or inclines.
- Ride-on toys should be used with caution since skill is required to avoid falls or collisions causing injury to the user or third parties.
- Shoes must be worn at all times.
- Only one rider at a time.
- Maximum weight: 50 lbs. (23 kg) per child.
- Not to be used by children over 36 months due to size limitations.