

Ceiling Light

Instruction Manual

Mode d'emploi

Betriebsanleitung

Manuale d'istruzioni

Manual de instrucciones

Manual de Instruções

Instrukcja

Руководство по эксплуатации

Návod k použití

Kezelési útmutató

Priručnik s uputama

Uputstvo za upotrebu

Part numbers: 52290, 52291, 52292, 52293,
52294, 52295, 52296, 52297

 Verbatim™

1x Part number: 52290, 52291, 52292, 52293, 52294, 52295, 52296, 52297

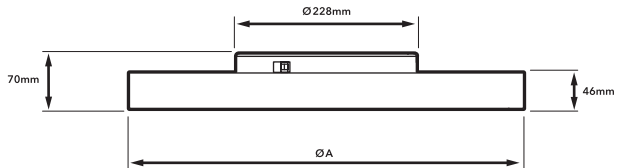

IP40

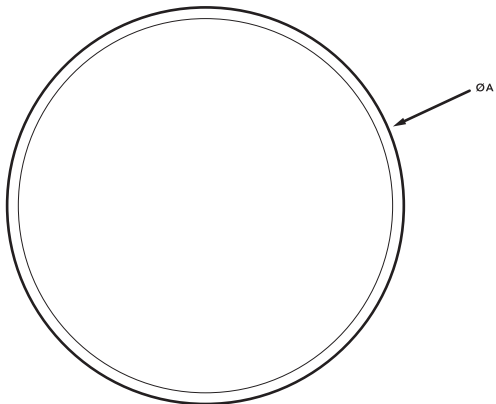

Mounting Accessories

x2



x2



x4 (ø320mm)

x6 (ø500mm)

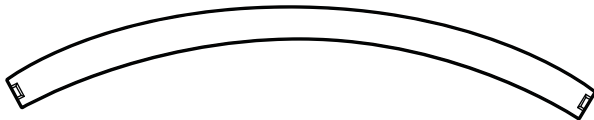

x1

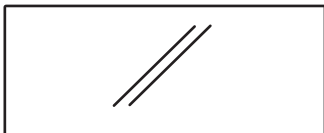

LED Ceiling Light Specifications

| | |
|--------------------|---------|
| Part No. | 52290 |
| Power (W) | 18 |
| Voltage (V) | 220-240 |
| Luminous flux (lm) | 1800 |
| CCT (K) | 3000 |
| Lifetime (hours) | 50 000 |
| A | 320mm |
| Weight (Kg) | 1.85 |
| Safety Class | Class I |
| Protection Class | IP40 |

| | |
|--------------------|---------|
| Part No. | 52291 |
| Power (W) | 35 |
| Voltage (V) | 220-240 |
| Luminous flux (lm) | 3500 |
| CCT (K) | 3000 |
| Lifetime (hours) | 50 000 |
| A | 500mm |
| Weight (Kg) | 3.1 |
| Safety Class | Class I |
| Protection Class | IP40 |

| | |
|--------------------|---------|
| Part No. | 52292 |
| Power (W) | 18 |
| Voltage (V) | 220-240 |
| Luminous flux (lm) | 1850 |
| CCT (K) | 4000 |
| Lifetime (hours) | 50 000 |
| A | 320mm |
| Weight (Kg) | 1.85 |
| Safety Class | Class I |
| Protection Class | IP40 |

| | |
|--------------------|---------|
| Part No. | 52293 |
| Power (W) | 35 |
| Voltage (V) | 220-240 |
| Luminous flux (lm) | 3600 |
| CCT (K) | 4000 |
| Lifetime (hours) | 50 000 |
| A | 500mm |
| Weight (Kg) | 3.1 |
| Safety Class | Class I |
| Protection Class | IP40 |

LED Ceiling Light Specifications

| | |
|--------------------|---------|
| Part No. | 52294 |
| Power (W) | 18 |
| Voltage (V) | 220-240 |
| Luminous flux (lm) | 1450 |
| CCT (K) | 3000 |
| Lifetime (hours) | 50 000 |
| A | 320mm |
| Weight (Kg) | 1.85 |
| Safety Class | Class I |
| Protection Class | IP40 |
| UGR | <19 |

| | |
|--------------------|---------|
| Part No. | 52295 |
| Power (W) | 35 |
| Voltage (V) | 220-240 |
| Luminous flux (lm) | 2800 |
| CCT (K) | 3000 |
| Lifetime (hours) | 50 000 |
| A | 500mm |
| Weight (Kg) | 3.1 |
| Safety Class | Class I |
| Protection Class | IP40 |
| UGR | <19 |

| | |
|--------------------|---------|
| Part No. | 52296 |
| Power (W) | 18 |
| Voltage (V) | 220-240 |
| Luminous flux (lm) | 1500 |
| CCT (K) | 4000 |
| Lifetime (hours) | 50 000 |
| A | 320mm |
| Weight (Kg) | 1.85 |
| Safety Class | Class I |
| Protection Class | IP40 |
| UGR | <19 |

| | |
|--------------------|---------|
| Part No. | 52297 |
| Power (W) | 35 |
| Voltage (V) | 220-240 |
| Luminous flux (lm) | 2900 |
| CCT (K) | 4000 |
| Lifetime (hours) | 50 000 |
| A | 500mm |
| Weight (Kg) | 3.1 |
| Safety Class | Class I |
| Protection Class | IP40 |
| UGR | <19 |

Specifications subject to change without notice - Caractéristique sujette à modification et ce sans préavis - Technische Daten können ohne vorherige Ankündigung geändert werden - Specifiche soggette a modifiche senza preavviso - Especificaciones sujetas a cambio sin previo aviso - Especificação sujeita a alteração sem aviso - Dane techniczne mogą ulec zmianie bez wcześniejszego powiadomienia - Спецификация может быть изменена без уведомления - Technické údaje podléhají změnám bez předchozího upozornění - Az adatok külön értesítés nélkül megváltozhatnak - Specifikacija podleže promjenama bez obaveštenja - Tehnički podaci podložni su promjenama bez prethodne najave

Installation Procedure

1

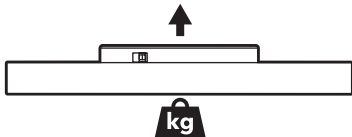

OFF



Diffuser



Do not push
the diffuser

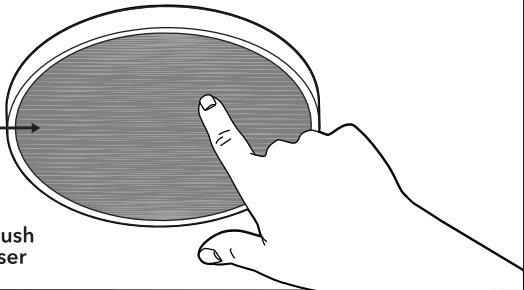

Installation Procedure

2

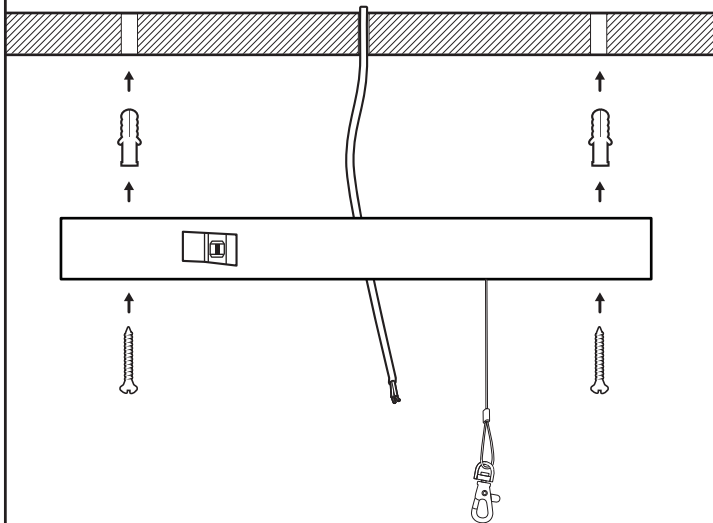

Installation Procedure

3

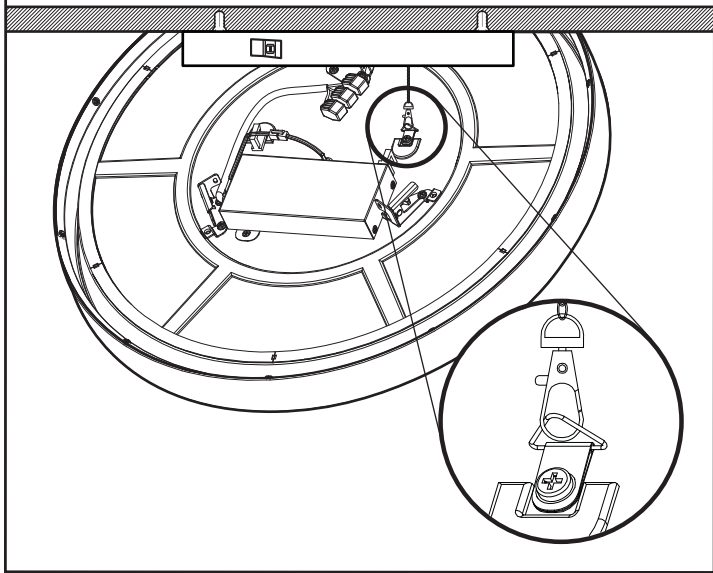

Installation Procedure

4

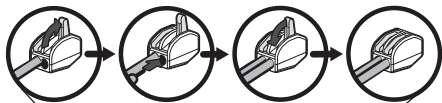

L - Brown



N - Blue



 Green-Yellow

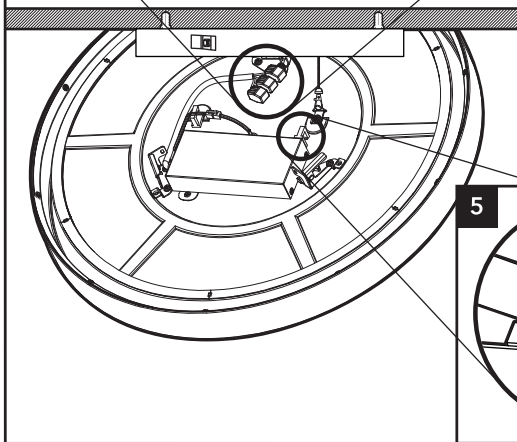

5

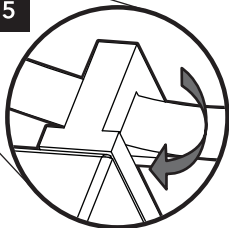

Installation Procedure

6

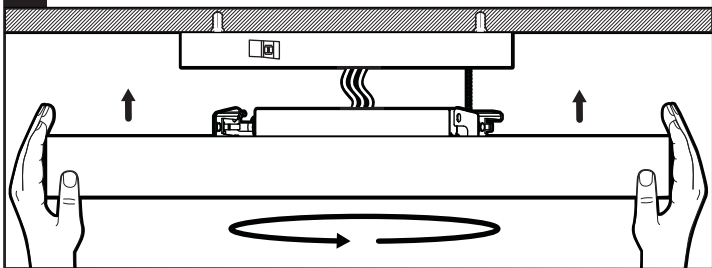

7

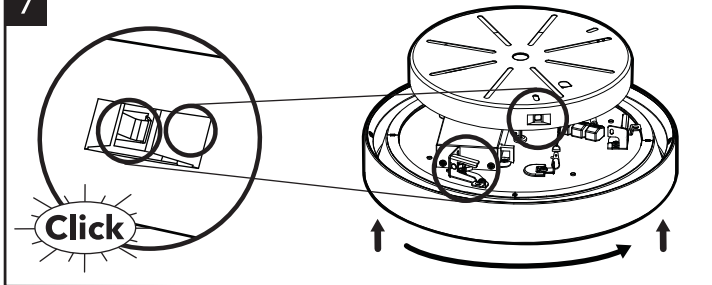

Installation Procedure

8

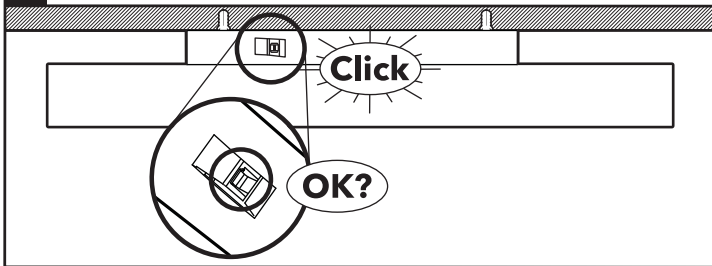

9

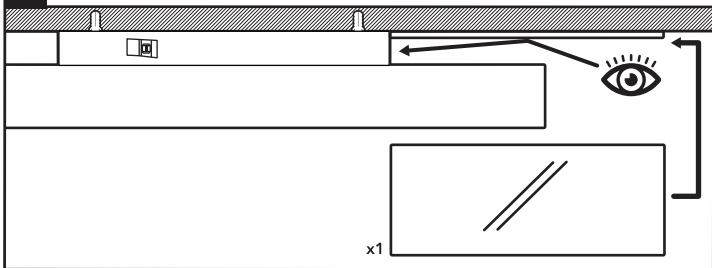

Installation Procedure

10 OPTIONAL: INSTALATION WITHOUT CORONA EFFECT

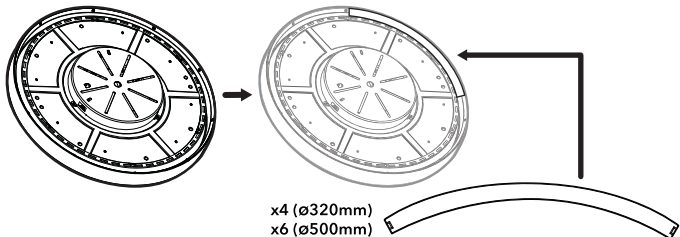

11

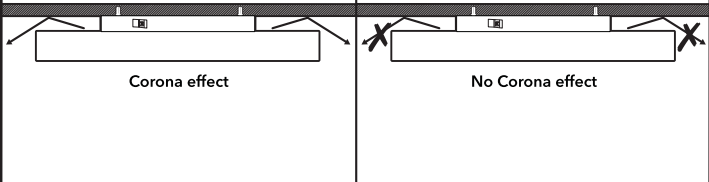

English

Safety Instructions



This product is for indoor use only.



This product is only dimmable when used in conjunction with a dimmable driver.
Please visit www.verbatim.com for dimming options.



Always disconnect the product from mains voltage before installing or replacing it.



Regional installation regulations should be observed.



Installation and repairs should only be carried out by a qualified person and using genuine spare parts. Incorrect repairs could pose a significant risk.
Please store in a safe place.



If there is any malfunction with the product, please exchange the whole luminaire.

3 year limited warranty – for further details visit www.verbatim.com/warranty.

If you have any questions about this product, please contact the Verbatim support team – www.verbatim.com/support

Français

Instructions de sécurité



Ce produit est destiné à un usage en intérieur uniquement.



La fonctionnalité de variation d'intensité de ce produit requiert l'utilisation conjointe d'un pilote de régulation d'intensité. Rendez-vous à l'adresse www.verbatim.com pour en savoir plus sur les options proposées.



Débranchez toujours le produit de l'alimentation secteur avant d'effectuer une installation ou un remplacement.



Les prérogatives régionales doivent être prises en compte.



Les procédures d'installation et de réparation doivent uniquement être effectuées par une personne qualifiée et à l'aide de pièces de rechange authentiques. L'utilisation de pièces de rechange non conformes peut se révéler dangereuse. Conservez ce produit dans un lieu sûr.



En cas de dysfonctionnement du produit, échangez l'appareil d'éclairage complet.

Wichtige Sicherheitshinweise



Dieses Produkt darf nur im Innenbereich verwendet werden.



Dieses Produkt ist nur in Verbindung mit einem dimmbaren Treiber dimmbar. Dimmoptionen finden Sie auf www.verbatim.com.



Trennen Sie das Produkt immer vom Stromnetz, bevor Sie es anbringen oder auswechseln.



Vor Ort geltende Installationsvorschriften sind einzuhalten.



Installations- und Reparaturarbeiten sollten ausschließlich von einer qualifizierten Fachkraft und unter Verwendung von Original-Ersatzteilen durchgeführt werden. Nicht ordnungsgemäß durchgeführte Reparaturen stellen ein erhebliches Risiko dar. Bitte sicher aufbewahren.



Falls bei dem Produkt jegliche Fehler oder Funktionsstörungen auftreten, tauschen Sie bitte den gesamten Beleuchtungskörper aus.

Informazioni di sicurezza



Questo prodotto è progettato esclusivamente per essere utilizzato in ambienti chiusi.



Questo prodotto è a luminosità regolabile solo se utilizzato con il relativo driver. Per le opzioni di regolazione della luminosità, visitare il sito www.verbatim.com.



Scollegare sempre il prodotto da una presa elettrica in tensione prima di installarlo o sostituirlo.



Osservare la normativa locale per l'installazione.



Installazione e riparazioni devono essere eseguite solo da una persona qualificata, usando parti di ricambio originali. Le riparazioni errate possono comportare rischi significativi. Conservare in un luogo sicuro.



In caso di malfunzionamento del prodotto, cambiare l'intero apparecchio di illuminazione.

Español

Instrucciones de seguridad



Este producto sólo debe usarse en interiores.



Este producto solo puede atenuarse cuando se utiliza conjuntamente con un atenuador. Visite www.verbatim.com para consultar las opciones disponibles de atenuación.



Desconecte siempre el producto de la red de alimentación antes de instalarlo o sustituirlo.



Deben cumplirse las normativas regionales sobre la instalación.



La instalación y las reparaciones solo debe llevarla a cabo una persona cualificada y con piezas de repuesto originales. Las reparaciones incorrectas podrían entrañar graves riesgos. Guarde el producto en un lugar seguro.



Si el producto no funciona correctamente, cambie toda la luminaria.

Garantía limitada de 3 años. Para obtener más información, visite www.verbatim.com/warranty. Si tiene alguna pregunta sobre este producto, póngase en contacto con el equipo de soporte de Verbatim: www.verbatim.com/support

Português

Instrucciones de seguridad



Este produto destina-se a ser utilizado apenas em ambientes interiores.



Este produto só é regulável ao nível da intensidade da luz em conjugação com um controlador também regulável a esse nível. Visite o site www.verbatim.com para conhecer as opções de regulação da intensidade da luz.



Desligue sempre o produto da corrente antes de o instalar ou substituir.



Os regulamentos regionais de instalação devem ser respeitados.



A instalação e as reparações só devem ser realizadas por uma pessoa qualificada e usando peças sobresselentes originais. Reparações incorrectas poderão representar um risco significativo. Guarde num local seguro.



Se ocorrer alguma anomalia no produto, substitua toda a luminária.

Instrukcje bezpieczeństwa



Produkt należy stosować tylko wewnątrz pomieszczeń.



Warunkiem uzyskania możliwości ściemniania jest skorzystanie ze sterownika ściemniającego. Informacje o możliwościach ściemniania dostępne są na stronie www.verbatim.com.



Przed zainstalowaniem lub wymianą produktu należy go zawsze odłączyć od sieci elektrycznej.



Należy przestrzegać lokalnych przepisów dotyczących montażu.



Montaż i naprawa mogą być wykonywane wyłącznie przez wykwalifikowane osoby i za pomocą oryginalnych części zamiennych. Nieprawidłowa realizacja naprawy może stwarzać znaczne zagrożenie. Przechowywać w bezpiecznym miejscu.



W przypadku awarii produktu należy wymienić całą oprawę oświetleniową.

Инструкции по технике безопасности



Это изделие предназначено для эксплуатации исключительно внутри помещения.



Для использования этого изделия со светорегулятором необходим драйвер.
Дополнительные сведения см. на сайте www.verbatim.com.



Всегда отключайте устройство от сетевого напряжения перед его установкой или заменой.



Должны соблюдаться региональные требования к установке.



Установка и ремонт должны производиться только квалифицированным специалистом с использованием оригинальных запасных частей. Последствия неправильного ремонта могут представлять серьезную опасность. Хранить в безопасном месте.



Если изделие неисправно, замените его целиком.

Česky

Bezpečnostní pokyny



Tento produkt je určen pouze pro použití v budovách.



Tento produkt je stmívatelný pouze při použití se stmívatelným ovladačem. Navštivte stránky www.verbatim.com, kde najdete informace o možnostech stmívání.



Před instalací nebo výměnou vždy odpojte produkt od zdroje napájení.



Je třeba dodržet místní předpisy pro montáž.



Montáž a opravy smí provádět pouze kvalifikované osoby, které používají originální náhradní díly. Nesprávné opravy mohou představovat vysoké riziko. Uchovávejte na bezpečném místě.



Pokud dojde k jakémukoli selhání produktu, vyměňte celou jednotku lampy.

Třiletá omezená záruka. Více informací naleznete na stránce www.verbatim.com/warranty. Máte-li k tomuto produktu nějaké otázky, kontaktujte tým podpory společnosti Verbatim – www.verbatim.com/support.

Magyar

Biztonsági utasítások



A termék kizárólag beltéri használatra való.



Ezen a terméken csak akkor működik a fényerőszabályzás, ha fényerőszabályzó előtéttel együtt használja. Kérjük, látogasson el a www.verbatim.com webhelyre a fényerőszabályzási lehetőségek megtekintéséhez.



Üzembe helyezés vagy csere előtt mindig áramtalanítsa a készüléket a tápkábel kihúzásával.



A helyi telepítési követelményeket is figyelembe kell venni.



A telepítést és javítást szakembernek kell végeznie eredeti pótalkatrészek felhasználásával. A nem megfelelő javítás komoly kockázatot jelenthet. Csak biztonságos helyen tárolja!



A termék meghibásodása esetén az egész világítótestet cserélje ki.

Hrvatski

Sigurnosne upute



Ovaj proizvod namijenjen je samo za upotrebu u zatvorenom.



Proizvod je prigušiv samo kada se upotrebljava s pogonskim sklopom za prigušivanje. Posjetite www.verbatim.com i provjerite dostupne mogućnosti prigušivanja.



Prije svake instalacije ili zamjene obavezno isključite proizvod iz naponske mreže.



Moraju se poštovati regionalni propisi za instalaciju.



Instalaciju i popravak trebaju obavljati samo kvalificirani serviseri, korištenjem originalnih rezervnih dijelova. Nepravilni popravci mogu uzrokovati značajne rizike. Čuvajte na sigurnom mjestu.



Ako je proizvod u kvaru, zamijenite ga cijelog.

Ograničeno 3-godišnje jamstvo – za više informacija posjetite www.verbatim.com/warranty. Ukoliko imate pitanja u vezi ovog proizvoda, obratite se timu za podršku tvrtke Verbatim – www.verbatim.com/support

Srpski

Sigurnosne instrukcije



Ovaj proizvod se može koristiti samo u zatvorenom prostoru.



Ovaj proizvod se može prigušiti samo kada se koristi uz drajvere koji se mogu prigušivati. Opcije za prigušivanje potražite na www.verbatim.com.



Uvek isključite proizvod iz strujne mreže pre instalacije ili zamene.



Potrebno je poštivati regionalne propise za instalaciju.



Instalaciju i popravke bi trebalo da vrši samo kvalifi kovana osoba koristeći originalne rezervne delove. Nepravilne popravke bi mogle da dovedu do značajnog rizika. Držite na bezbednom mestu.



Ako se proizvod pokvari, zamenite celo svetlosno telo.

CE Declaration – EC Declaration of Conformity

It is hereby declared that this product complied with the essential protection requirements of Council Directive 2004/108/EC and its amendments on the approximation of the laws of the Member States relating to electromagnetic compatibility. This product also complied with the listed harmonized standards as referred to in the Council Directive 2006/95/EC , Low Voltage Directive.

This declaration applies to all specimens manufactured identical to the model submitted for testing/evaluation.

EN 55015

EN 62471-1+IEC/TR 62471-2

EN 61000-3-2

EN 62031

EN 61000-3-3

EN 60598-1 / EN 60598-2-2

EN 61547

EN 62493



SELV CE EAC

WEEE Notice

The Directive on Waste Electrical and Electronic Equipment (WEEE), which entered into force as European law on 13th February 2003, resulted in a major change in the treatment of electrical equipment at end-of-life.



The WEEE logo (shown at the left) indicates that this product must be disposed in accordance with the Waste Electrical and Electronic Equipment Directive and not with your other household waste.

Company Details

www.verbatim.com

- EUROPE/ MIDDLE EAST/ AFRICA: Verbatim GmbH, Düsseldorfferstrasse 13, 65760 Eschborn/Germany
- AMERICAS: USA Verbatim Americas LLC. Charlotte, NC
- AUSTRALIA/ NEW ZEALAND: Verbatim Australia Pty Ltd, Unit 6, 450 Princes Highway, Noble Park, Victoria, 3174 Australia
Tel: +61 3 9790 8999 Fax:+61 3 9790 8955 Email:support@verbatim.com.au

銷售公司：香港威寶有限公司
公司地址：香港九龍尖沙咀東部加連威老道92號
幸福中心1101-2室

銷售公司：威宝国际贸易(深圳)有限公司
公司地址：深圳市福田区泰然九路海松大厦B座1406室

台灣地區
委製商/進口商：台灣威寶國際貿易股份有限公司
公司地址：台北市基隆路二段166號4樓
聯絡電話：02-23771698

“VERBATIM” and  logo are trademarks, please refer to www.verbatim.com/trademarks

- Made in China • Fabriqué en Chine
- Сделано в Китае • 原產地：中國 • 原产地：中国

