



SCETA

EL. HEIGHT ADJUSTABLE SYSTEM WITH H-MOBILE STAND

**Factory:**

Conen Produkte GmbH & Co. KG  
Conenstr. 4  
54497 Morbach-Gonzerath  
Germany

**International sales department:**

Mr. Luc van der Sterren  
Office: +49 65 33 75 311  
Cell: +31 612 495 098  
Email: [Luc@conenmounts.com](mailto:Luc@conenmounts.com)

Mr. Arnaud Gielen  
Office: +49 6533 75 310  
Cell: +49 172 655 84 61  
Email: [Arnaud@conenmounts.com](mailto:Arnaud@conenmounts.com)



### PRODUCT FEATURES

- ◆ Electrical height adjustable column, natural anodized
- ◆ 500 mm / 19.7" height adjustment
- ◆ H-shaped mobile stand with four heavy duty castors – two with brakes, RAL 9006 white aluminum
- ◆ Mount for use with 42" – 100" display
- ◆ VESA 200 x 200 up to 800 x 600
- ◆ Maximum load approximately 150 kg / 330.7 lbs

### HIGHEST POSITION

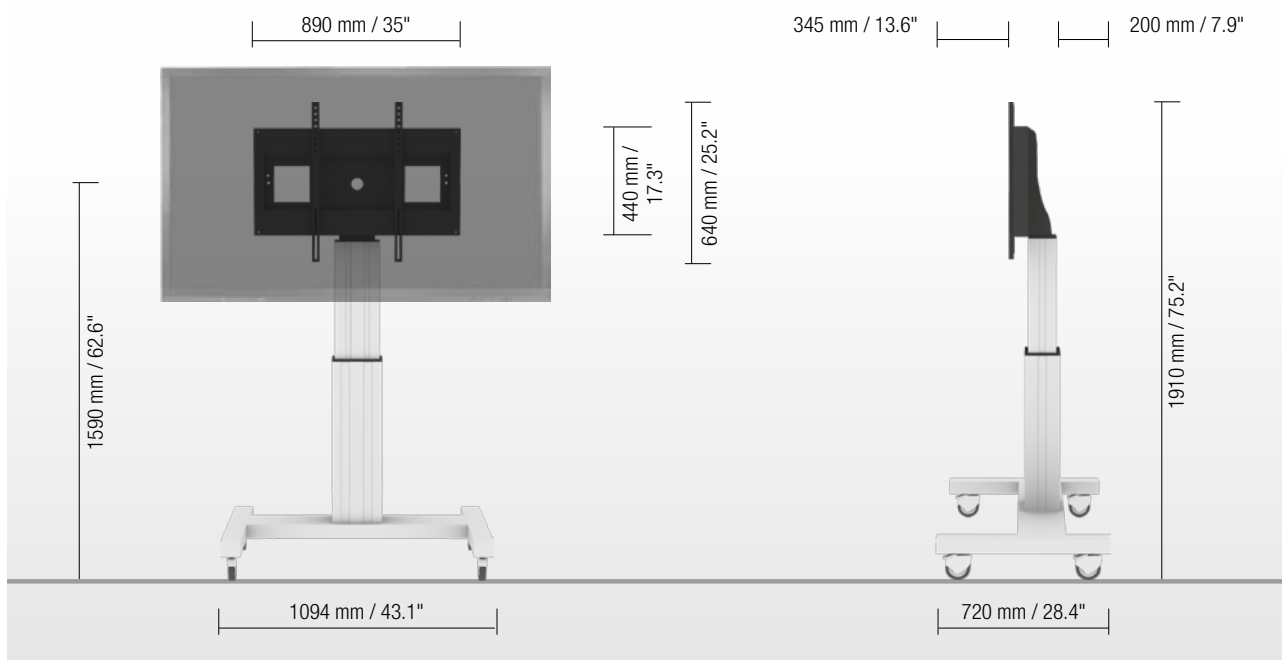

### LOWEST POSITION

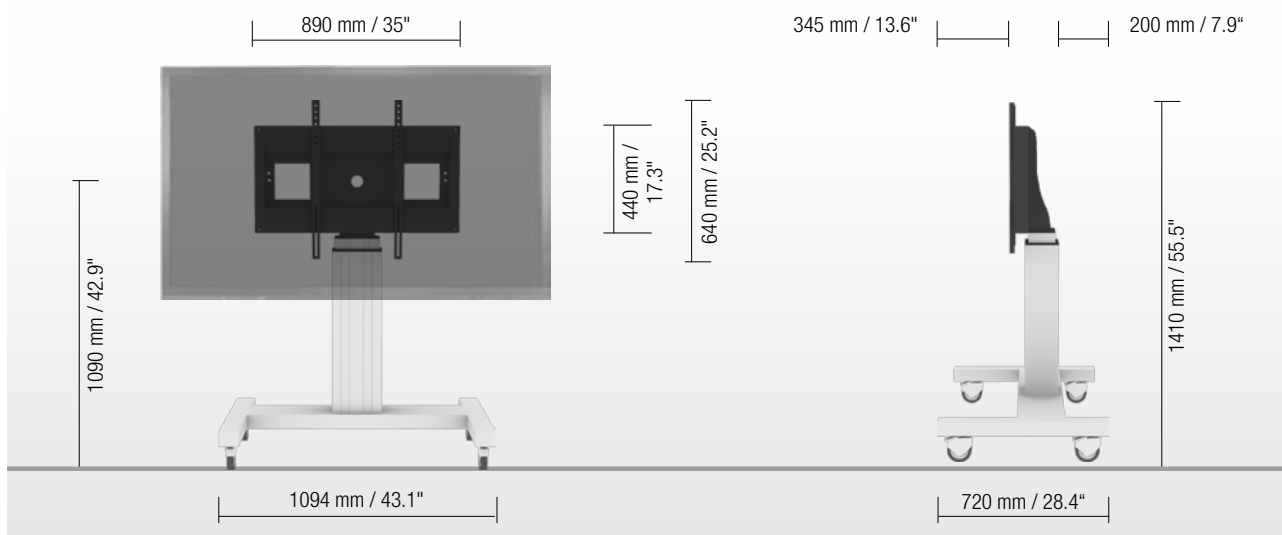

DETAIL VIEWS



Pull & release locking brackets for easier mounting of display



Smooth running & lockable castors



Wired remote control

AVAILABLE ACCESSORIES

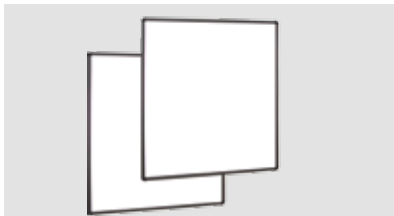

SWBW-..

2 whiteboard side wings

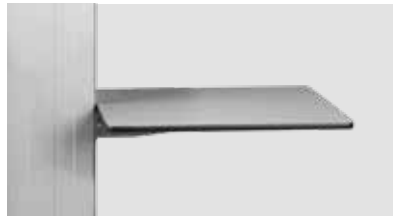

LAP4-..

Side shelf

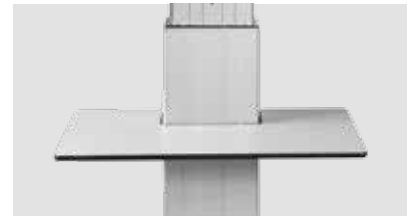

FSH-..

Front shelf



MINI-FUJI

Lockable mini PC bracket



AFSCETAKB

Keyboard shelf



GRIFF-SCETA

2 Handles (not in combination with SWBW-..)



LAP-CAB

Lockable notebook cabinet



VCTSCETA

Video conference camera top shelf



CCE-EXT20

Extender (200 mm / 7.9")



LOCKSCETA

Lockable wall bracket

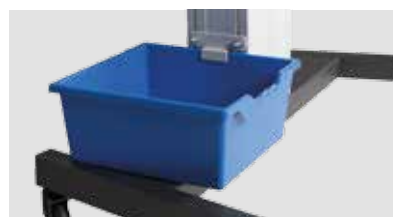

SCETA-ETH (C2-HB)

2 box holders (boxes on request)



SCHLIESS-VH

Display securing padlock

SIZE INDEX

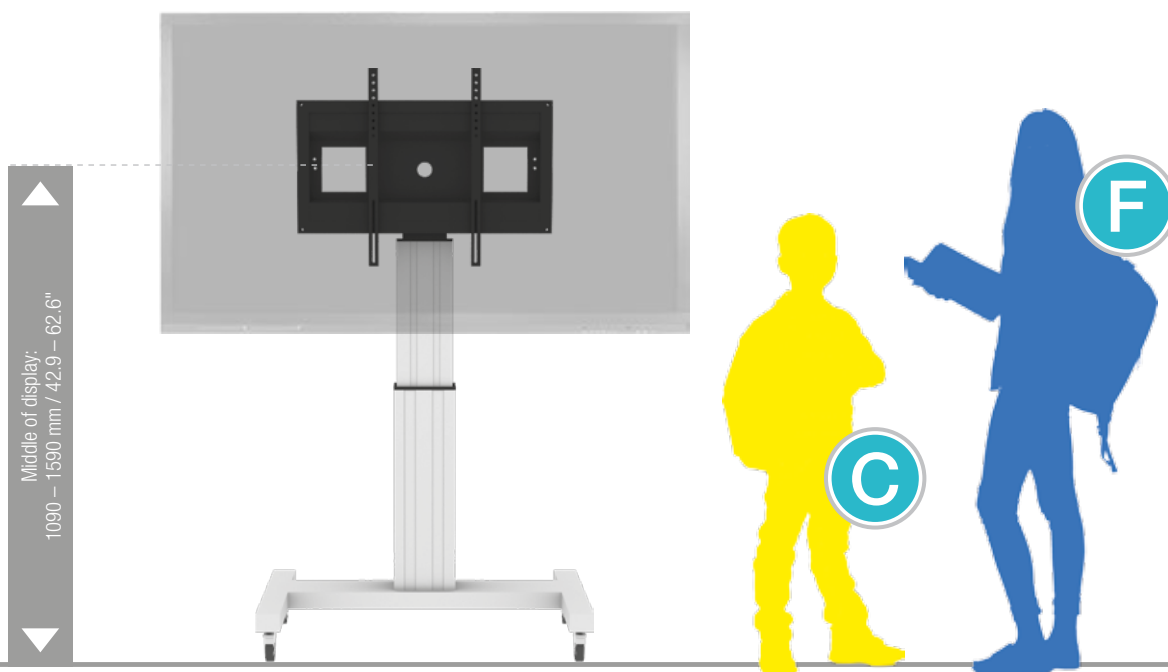

Department	Kindergarten			Primary school			Secondary school		Adults
	A	B	C	D	E	F	G		
Silhouette									
Age (years)	2 – 3	3 – 4	4 – 7	6 – 11	11 – 14	13 – 16	from 16		
Body size (mm / ")	930 – 980 37 – 38.6	1080 – 1210 42.5 – 47.6	1190 – 1420 46.9 – 56	1330 – 1590 52.4 – 62.6	1460 – 1765 57.5 – 69.5	1590 – 1880 62.6 – 74	1740 – 2070 68.5 – 81.5		
Color									

PACKING UNITS

Item no.	Description	Packing dimensions (mm / ")	Net weight (kg / lbs)	Gross weight (kg / lbs)
CCE-50	Electrical height adjustable column, 500 mm / 19.7" height adjustment, L = 700 mm / 27.6"	970 x 270 x 220 / 38.2 x 10.6 x 8.7	18 / 39.7	19,5 / 43
AF-SCETA-N	Display mount	160 x 900 x 450 / 6.3 x 35.4 x 17.1	11,7 / 25.8	13,6 / 30
MST-SCETA	H-shaped mobile stand	1140 x 780 x 150 / 44.9 x 30.7 x 5.9	20,7 / 45.6	24,2 / 53.4
Total weight			50,4 / 111.1	57,3 / 126.3