

MOTORIZED MONITOR WALL MOUNT, 50 CM OF VERTICAL TRAVEL

COLUMN BLACK ANODIZED, CENTER OF DISPLAY 99,5 - 149,5 CM

PRODUCT

Motorized monitor wall mount for 42"-100" (interactive) flat-panel displays.

The SCETAWLB is designed for flat panel displays up to 100". The units feature a sturdy display mount with integrated cable management and "pull & release" locking brackets for quick and easy mounting of the display.

The SCETAWLB monitor wall mount comes with a column that offers 50 cm / 20" of vertical travel.

The unit comes flat-packed in 2 cartons and is courier-shippable.

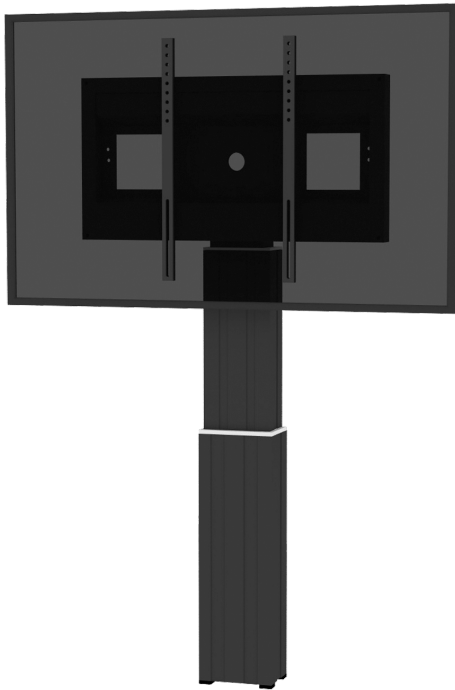

Accessories



Keyboard shelf



Extender for 2-part height adjustable aluminum columns



2 galvanized adjustable wall mounting brackets



Wall mounting set for Systems with one column



2 galvanized wall mounting brackets

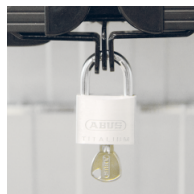

Brackets and wing lock for locking the side wings in front of the display

FEATURES

- > Heavy duty mount for displays up to 100"
- > "Pull & Release" brackets for easy mounting of display
- > VESA pattern, max. 800 x 600
- > Integrated cable management
- > 50 cm / 20" of smooth motorized height adjustment
- > Optimum stability thanks to 4 leveling feet and 2 wall mount brackets



Display mount



Wall mounted



Motorized height adjustable



Single display



5 years warranty



Max. load
136 kg / 299.8 lbs



Max. Vesa
800 x 600

Item number	SCETAWL B	
Vesa horizontal / Vesa vertical	300 mm - 800 mm / 200 mm - 600 mm	
Frame for all	42" - 100"	
Center to floor distance	995 mm - 1495 mm	39.2" - 58.9"
Load capacity	136 kg	299.8 lbs
Width / Height / Depth	890 mm / 1315 mm - 1815 mm / 165 mm	35" / 51.8" - 71.5" / 6.5"
Warranty	5 years limited warranty	
UL certificate	UL Listed	
Frame color	RAL 9005 deep black	
Column color	Black anodized	
Packages	Package dimensions WxHxD	Package weight
AF-SCETA-N	900 x 160 x 450 mm / 35.4 x 6.3 x 17.7"	13,6 kg / 30 lbs
CCE50-WB	970 x 270 x 220 mm / 38.2 x 10.6 x 8.7"	19,5 kg / 43 lbs
Total weight	33,1 kg / 73 lbs	

DIMENSIONS

in mm / inch

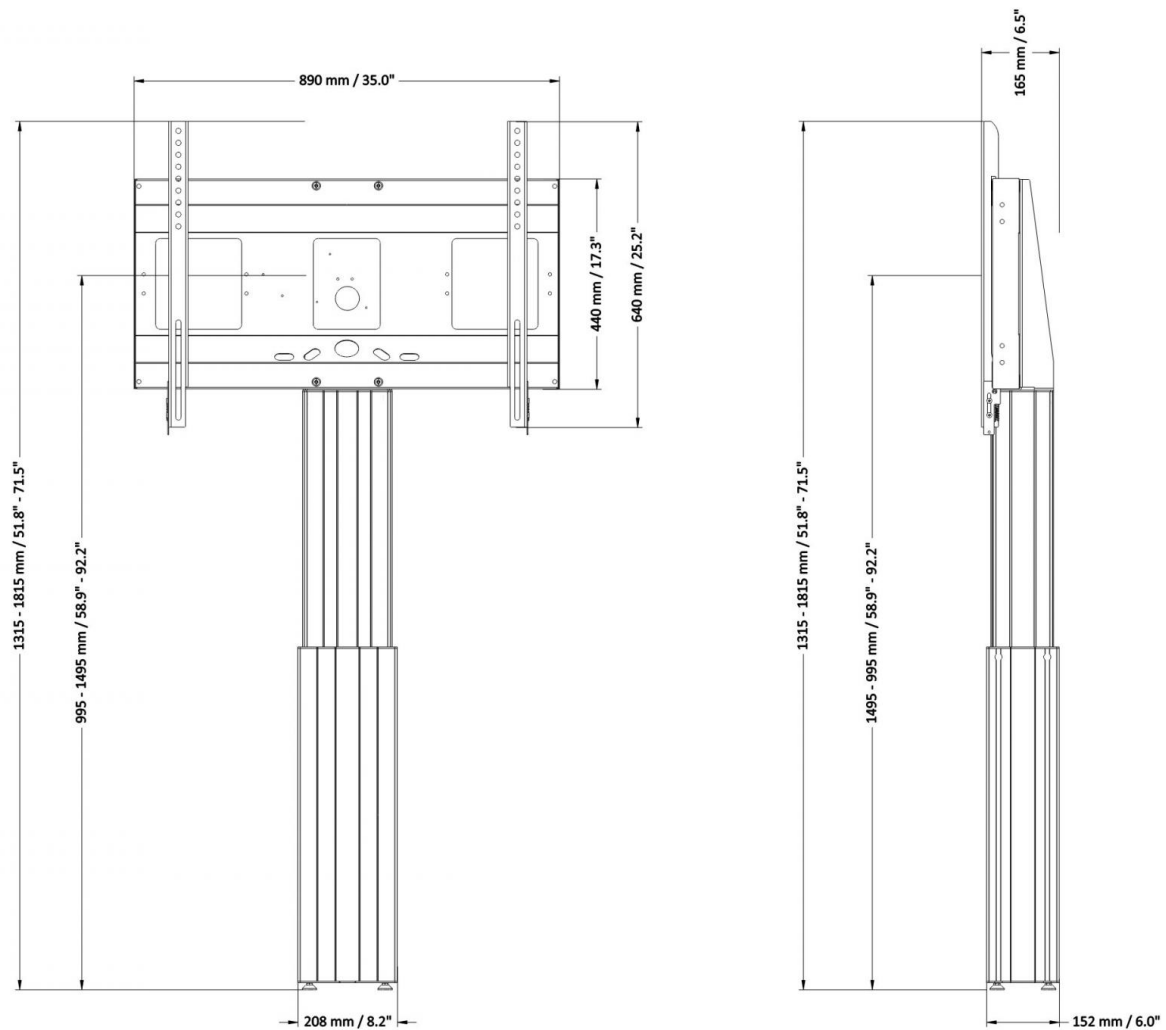

MANUFACTURER:

CONEN Produkte GmbH
 Conenstr. 4
 54497 Morbach-Gonzerath

Phone: +49 (0) 6533 75-100
 Fax: +49 (0) 6533 75-600
 E-Mail: info@conenmounts.com

Germany

www.conenmounts.com