



SCETAP

EL. HEIGHT ADJUSTABLE SYSTEM WITH FLOOR PLATE

Factory:

Conen Produkte GmbH & Co. KG
Conenstr. 4
54497 Morbach – Gonzerath
Germany

International sales department:

Mr. Luc van der Sterren
Office: +49 65 33 75 311
Cell: +31 612 495 098
Email: Luc@conenmounts.com

Mr. Arnaud Gielen
Office: +49 6533 75 310
Cell: +49 172 655 84 61
Email: Arnaud@conenmounts.com



PRODUCT FEATURES

- ◆ electrical height adjustable column, natural anodized
- ◆ 500 mm / 19.7" height adjustment
- ◆ Floor plate made of 8 mm / 0.3" strong steel, powder-coated, RAL 9006 white aluminum
- ◆ mount for use with 42" – 100" display
- ◆ VESA 200 x 200 up to 800 x 600
- ◆ maximum load approximately 150 kg / 330.7 lbs
- ◆ incl. wall brackets (70 mm / 2.8")

HÖCHSTE STELLUNG | HIGHEST POSITION

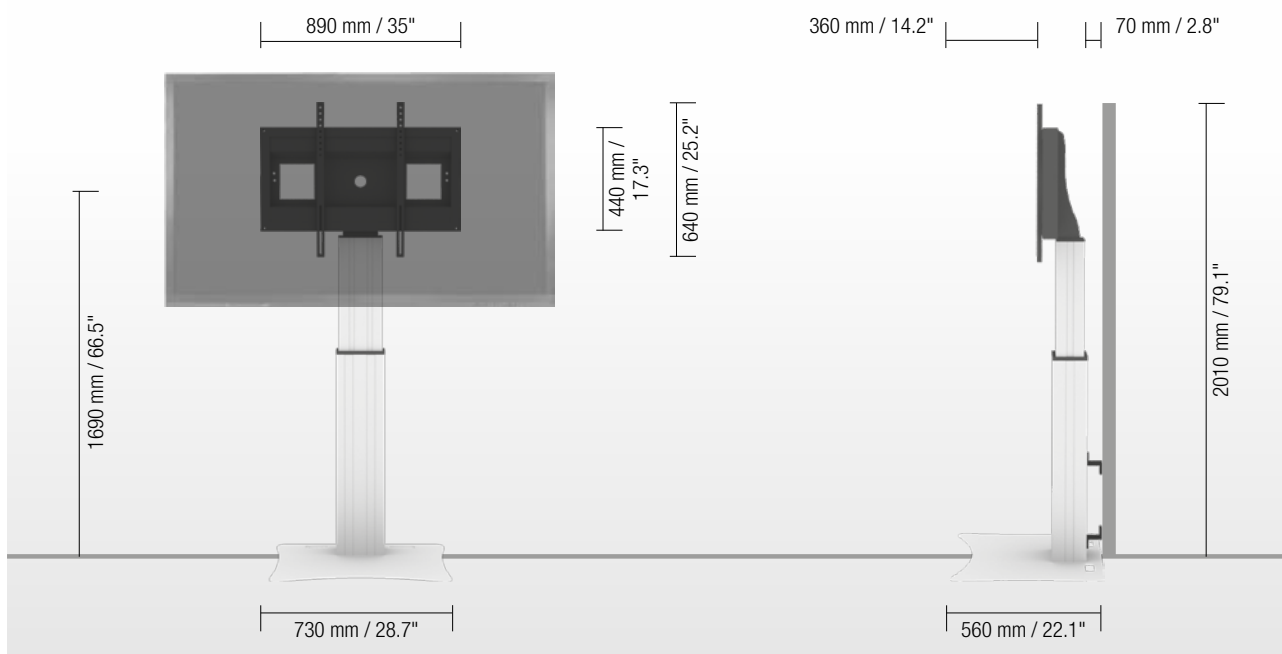

NIEDRIGSTE STELLUNG | LOWEST POSITION

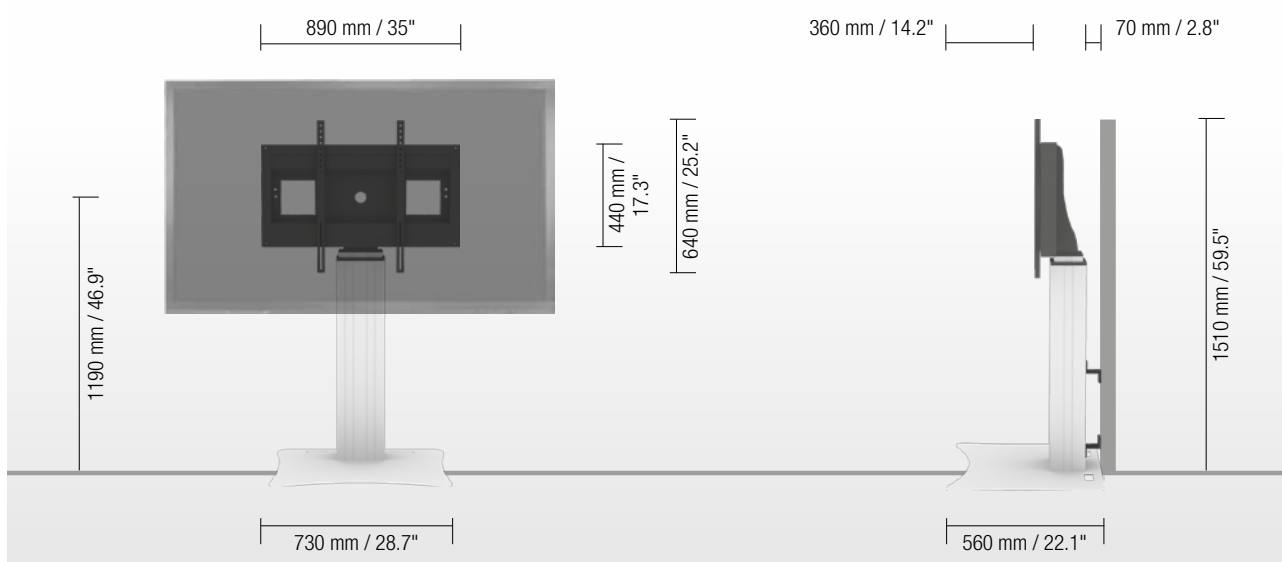

DETAIL VIEWS



Pull & release locking brackets for easier mounting of display

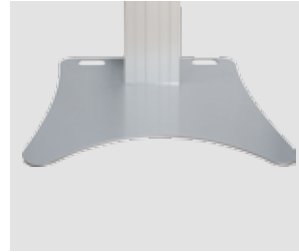

Floor plate



Wired remote control

AVAILABLE ACCESSORIES

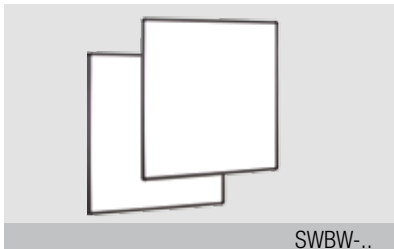

SWBW-..

2 whiteboard side wings



LAP4-..

Side shelf

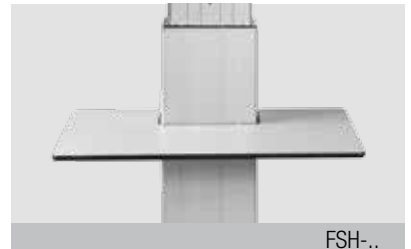

FSH-..

Front shelf



MINI-FUJI

Lockable mini PC bracket



AFSCETAKB

Keyboard shelf



VCTSCETA

Video conference camera top shelf



REM-FOOT

Foot remote control



CCE-EXT20

Extender (200 mm / 7.9")



SCHLISS-VH

Display securing padlock

SIZE INDEX

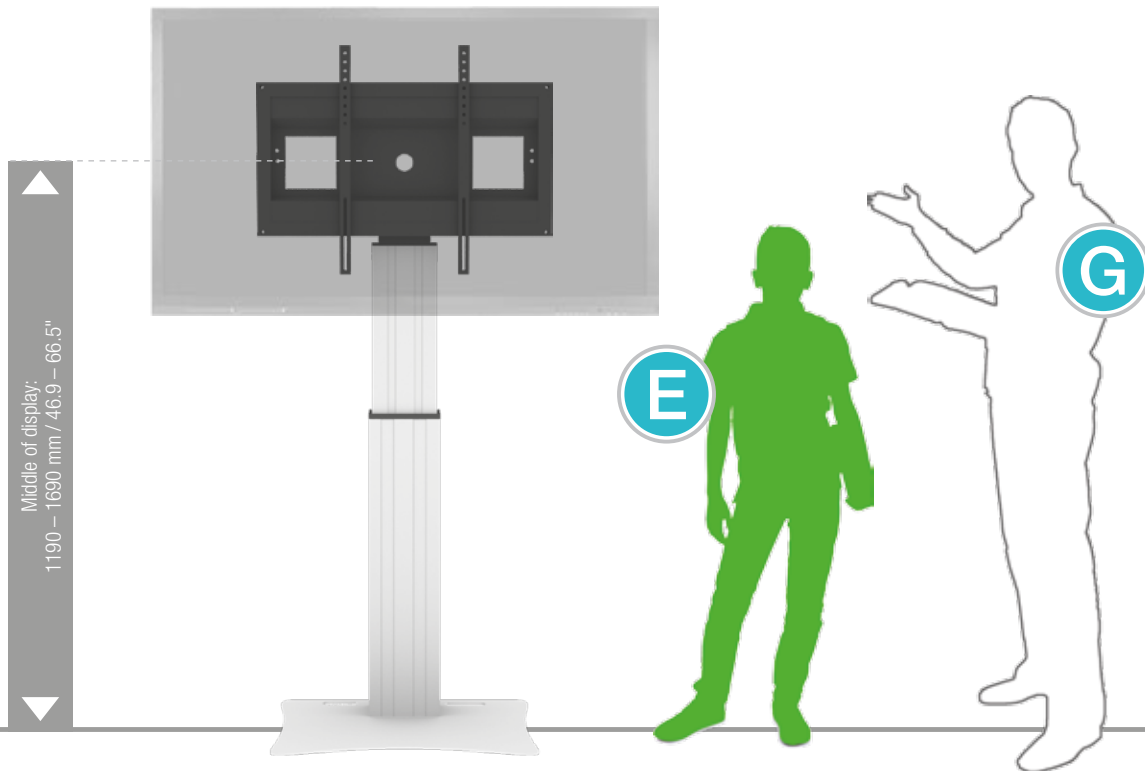

Department	Kindergarten				Primary school		Secondary school		Adults
Silhouette	A	B	C	D	E	F	G		
Age (years)	2 – 3	3 – 4	4 – 7	6 – 11	11 – 14	13 – 16	from 16		
Body size (mm / ")	930 – 980 37 – 38.6	1080 – 1210 42.5 – 47.6	1190 – 1420 46.9 – 56	1330 – 1590 52.4 – 62.6	1460 – 1765 57.5 – 69.5	1590 – 1880 62.6 – 74	1740 – 2070 68.5 – 81.5		
Color	Green	Purple	Yellow	Red	Light Green	Blue			

PACKING UNITS

Part. no.	Description	Packing dimensions (mm / ")	Net weight (kg / lbs)	Gross weight (kg / lbs)
CCE70-W	electrical height adjustable column, 500 mm / 19.7" height adjustment, L = 900 mm / 35.4"	1180 x 270 x 200 / 46.5 x 10.7 x 7.9	21,0 / 46.3	23,1 / 50.9
AF-SCETA-N	Display mount	160 x 900 x 450 / 6.3 x 35.4 x 17.1	11,7 / 25.8	13,6 / 30
PSTSCETA	Bodenplatte I Floor plate	20 x 750 x 600 / 0.8 x 29.5 x 23.6	21,0 / 46.3	21,8 / 48.1
Total weight			53,7 / 118.4	58,5 / 129.0