



SCEXLPL

EL. HEIGHT ADJUSTABLE SYSTEM WITH FLOOR PLATE

Factory:

Conen Produkte GmbH & Co. KG
Conenstr. 4
54497 Morbach-Gonzerath
Germany

International sales department:

Mr. Luc van der Sterren
Office: +49 65 33 75 311
Cell: +31 612 495 098
Email: Luc@conenmounts.com

Mr. Arnaud Gielen
Office: +49 6533 75 310
Cell: +49 172 655 84 61
Email: Arnaud@conenmounts.com



PRODUCT FEATURES

- ◆ Electrical height adjustable column, natural anodized
- ◆ 500 mm / 19.7" height adjustment
- ◆ Floor plate made of 8 mm / 0.3" strong steel, powder-coated, RAL 9006 white aluminum
- ◆ XL-display mount for use with 70" – 120" display
- ◆ VESA 300 x 200 up to 1200 x 600
- ◆ Maximum load approximately 150 kg / 330.7 lbs
- ◆ Incl. wall brackets (70 mm / 2.8")

HIGHEST POSITION

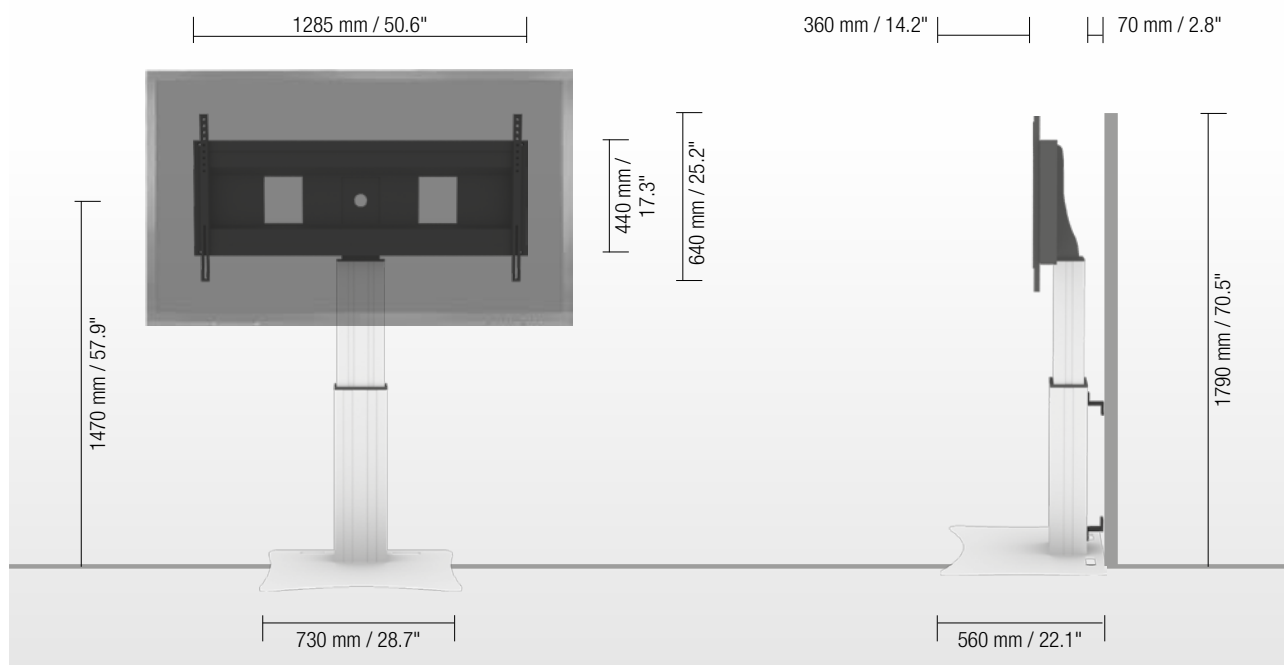

LOWEST POSITION

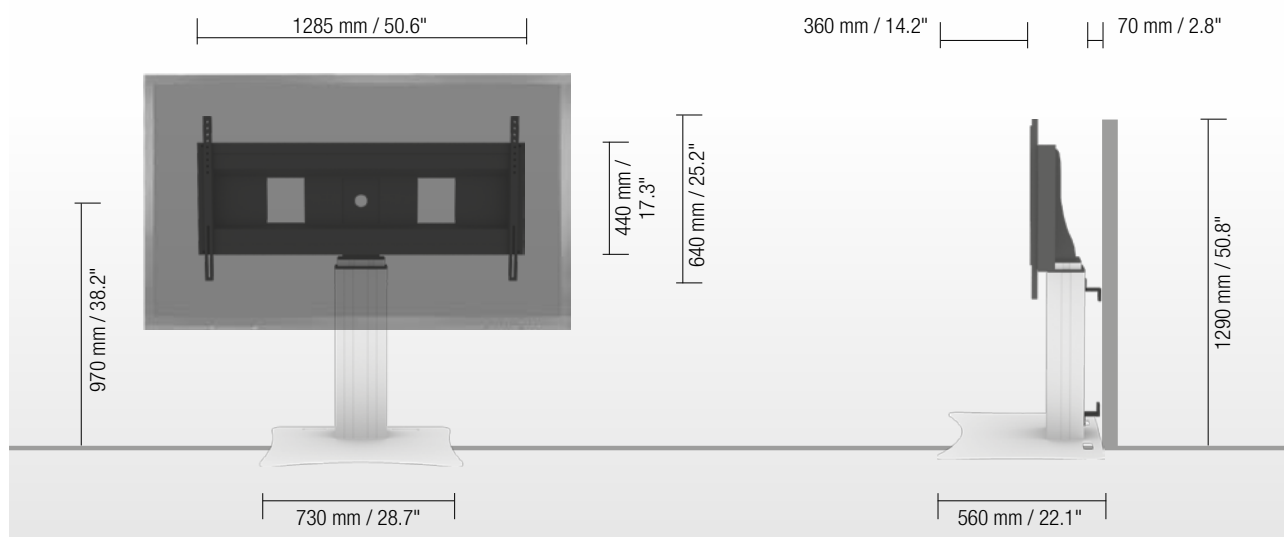

DETAIL VIEWS



Pull & release locking brackets for easier mounting of display

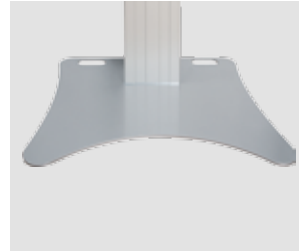

Floor plate



Wired remote control

AVAILABLE ACCESSORIES

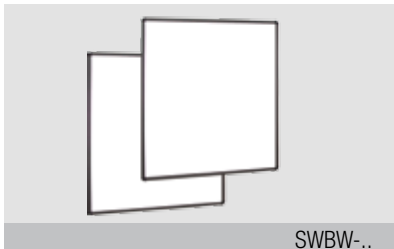

2 whiteboard side wings



Side shelf

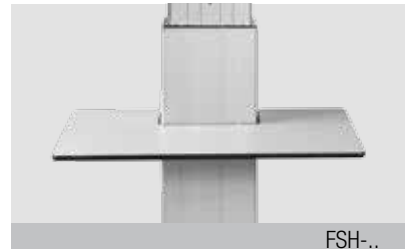

Front shelf



Lockable mini PC bracket



Keyboard shelf



Video conference camera top shelf



Foot remote control

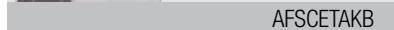

AFSCETAKB

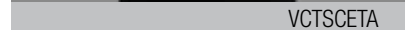

VCTSCETA



Extender (200 mm / 7.9")

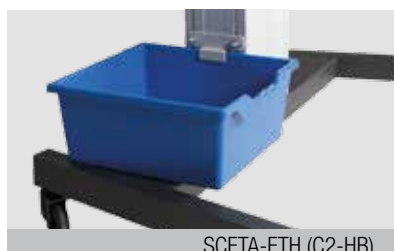

2 box holders (boxes on request)



Display securing padlock

CCE-EXT20

SCETA-ETH (C2-HB)

SCHLIESS-VH

SIZE INDEX

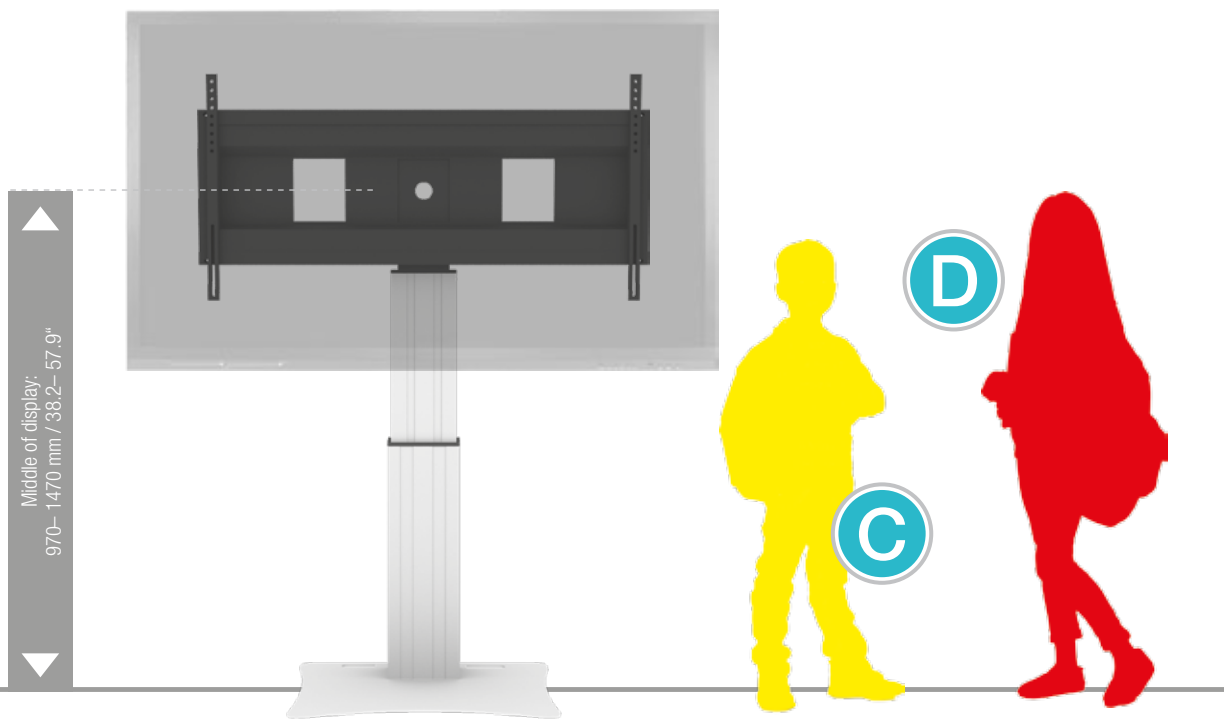

Department	Kindergarten			Primary school			Adults
	Kindergarten			Secondary school			
Silhouette	A	B	C	D	E	F	G
Age (years)	2 – 3	3 – 4	4 – 7	6 – 11	11 – 14	13 – 16	from 16
Body size (mm / ")	930 – 980 37 – 38.6	1080 – 1210 42.5 – 47.6	1190 – 1420 46.9 – 56	1330 – 1590 52.4 – 62.6	1460 – 1765 57.5 – 69.5	1590 – 1880 62.6 – 74	1740 – 2070 68.5 – 81.5
Color	Green	Purple	Yellow	Red	Light Green	Blue	

PACKING UNITS

Item no.	Description	Packing dimensions (mm / ")	Net weight (kg / lbs)	Gross weight (kg / lbs)
CCE50-W	Electrical height adjustable column, 500 mm / 19.7" height adjustment, L = 700 mm / 27.6"	970 x 270 x 220 / 38.2 x 10.6 x 8.7	18 / 39.7	19,5 / 43
AFSCETAN12	XL-display mount	1295 x 160 x 450 / 51 x 6.3 x 17.7	15 / 33.1	18 / 39.7
PSTSCETA	Floor plate	20 x 750 x 600 / 0.8 x 29.5 x 23.6	21 / 46.3	21,8 / 48.1
Total weight			54 / 119.1	59,3 / 130.7