



SCETADPB

EL. HÖHENVERSTELLBARES SYSTEM MIT BODENPLATTE
EL. HEIGHT ADJUSTABLE SYSTEM WITH FLOOR PLATE

Factory:

Conen Produkte GmbH & Co. KG
Conenstr. 4
54497 Morbach-Gonzerath
Germany

International sales department:

Mr. Luc van der Sterren
Office: +49 65 33 75 311
Cell: +31 612 495 098
Email: Luc@conenmounts.com

Mr. Arnaud Gielen
Office: +49 6533 75 310
Cell: +49 172 655 84 61
Email: Arnaud@conenmounts.com



PRODUKTEIGENSCHAFTEN | PRODUCT FEATURES

- ◆ 2 elektrisch höhenverstellbare Pylonen, schwarz eloxiert
 - ◆ 500 mm Hub
 - ◆ 8 mm starke XL-Bodenplatte, RAL 9006 Weißaluminium
 - ◆ XL-Halterung zur Verwendung mit 70" – 120" Display
 - ◆ VESA 300 x 200 bis 1200 x 600
 - ◆ Maximale Belastung ca. 250 kg
 - ◆ Inkl. Wandabstandshalter (70 mm)
- ◆ 2 electrical height adjustable columns, black anodized
 - ◆ 500 mm height adjustment
 - ◆ XL-floor plate made of 8 mm strong steel, powder-coated, RAL 9006 white aluminum
 - ◆ XL-display mount for use with 70" – 120" display
 - ◆ VESA 300 x 200 up to 1200 x 600
 - ◆ Maximum load approximately 250 kg
 - ◆ Incl. wall brackets (70 mm)

HÖCHSTE STELLUNG | HIGHEST POSITION

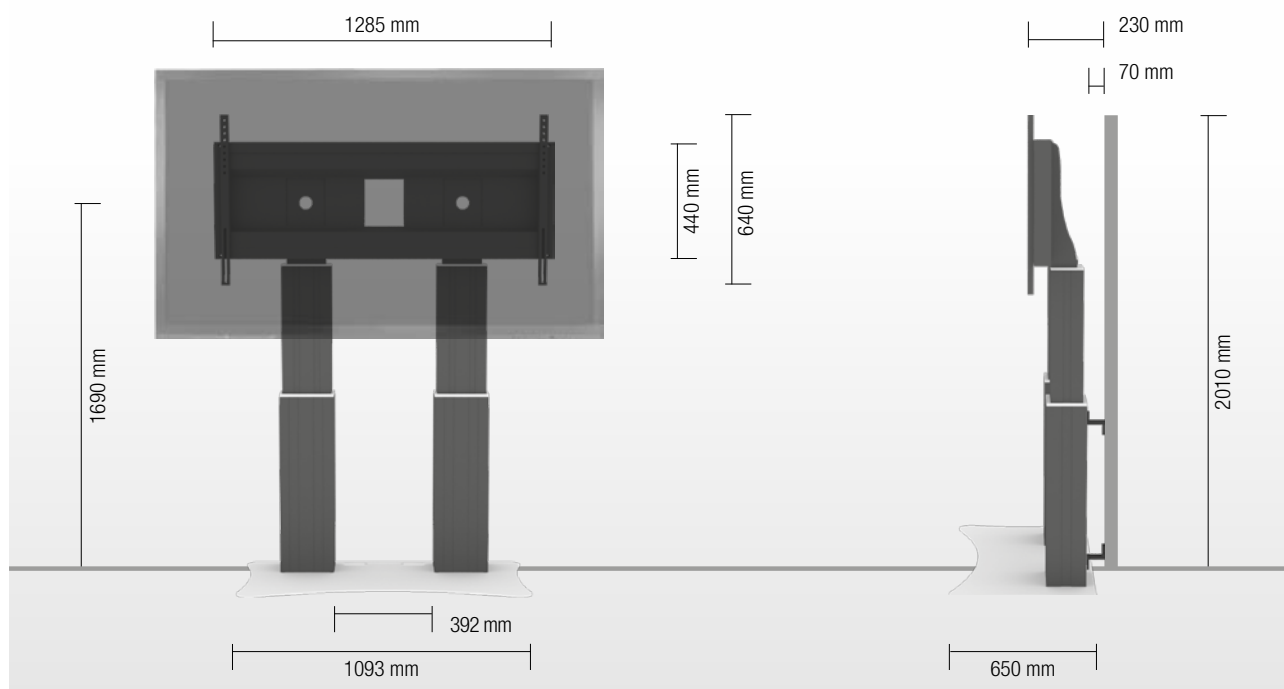

NIEDRIGSTE STELLUNG | LOWEST POSITION

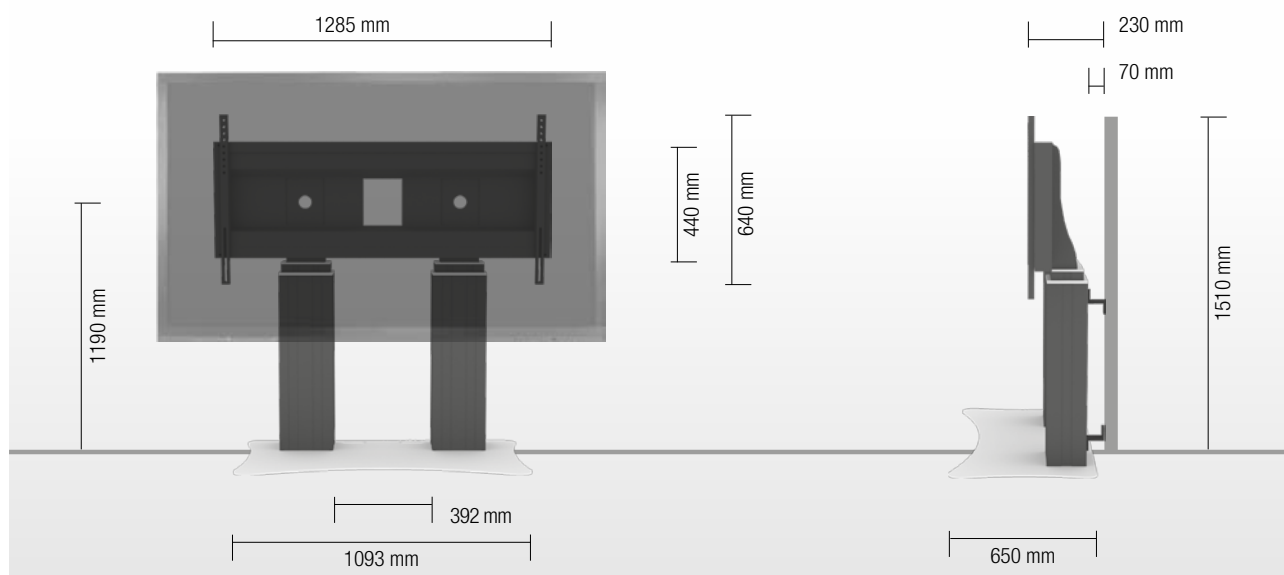

DETAILANSICHTEN | DETAIL VIEWS



Schnappklammern erleichtern die Montage
Pull & release locking brackets for easier mounting of display

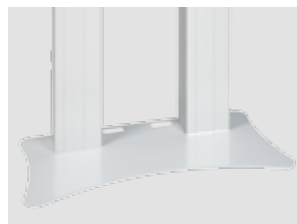

XL-Bodenplatte
XL-floor plate



Elektrische Höhenverstellung
Wired remote control

WÄHLBARES ZUBEHÖR | AVAILABLE ACCESSORIES

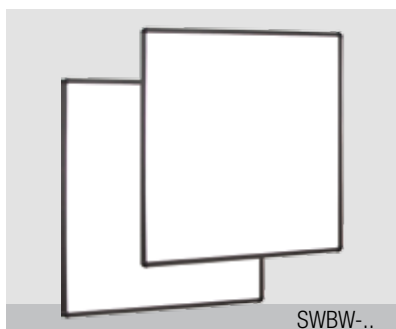

2 Whiteboard Seitenflügel
2 whiteboard side wings



Seitentisch
Side shelf



Abschließbare Mini-PC Halterung
Lockable mini PC bracket



Halter für Videokonferenzkameras
Video conference camera top shelf



Fußschalter
Foot remote control



Verlängerung (200 mm)
Extender (200 mm)



Display Sicherheitsschloss
Display securing padlock

GRÖßENINDEX | SIZE INDEX

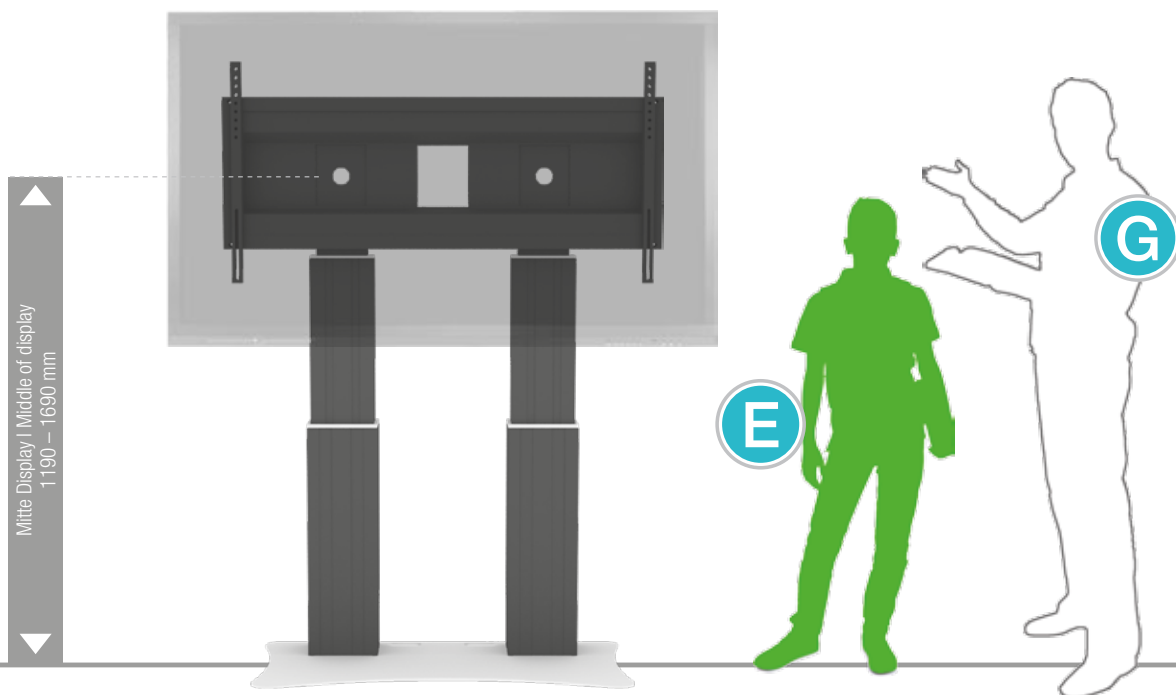

Department	Kindergarten			Primary school		Secondary school		Adults
	A	B	C	D	E	F	G	
Silhouette								
Age (years)	2 – 3	3 – 4	4 – 7	6 – 11	11 – 14	13 – 16	from 16	
Body size (mm / ")	930 – 980 37 – 38.6	1080 – 1210 42.5 – 47.6	1190 – 1420 46.9 – 56	1330 – 1590 52.4 – 62.6	1460 – 1765 57.5 – 69.5	1590 – 1880 62.6 – 74	1740 – 2070 68.5 – 81.5	
Color								

PACKEINHEITEN | PACKING UNITS

Artikel-Nr. Item no.	Beschreibung Description	Packmaße Packing dimensions (mm)	Nettogewicht Net weight (kg)	Bruttogewicht Gross weight (kg)
CCE70-WDB	2 x elektrisch höhenverstellbare Pylone, 500 mm Hub, L = 900 mm 2 x electrical height adjustable column, 500 mm height adjustment, L = 900 mm	2 x 1180 x 270 x 200	2 x 21	2 x 23,1
AFSCETAND	XL-Display Halterung XL-display mount	1295 x 160 x 450	15	18
PSTSCETAD	XL-Bodenplatte XL-floor plate	30 x 750 x 800	30	32
Gesamtgewicht Total weight			87	96,2



SCETADPB

EL. HEIGHT ADJUSTABLE SYSTEM WITH FLOOR PLATE

Factory:

Conen Produkte GmbH & Co. KG
Conenstr. 4
54497 Morbach-Gonzerath
Germany

International sales department:

Mr. Luc van der Sterren
Office: +49 65 33 75 311
Cell: +31 612 495 098
Email: Luc@conenmounts.com

Mr. Arnaud Gielen
Office: +49 6533 75 310
Cell: +49 172 655 84 61
Email: Arnaud@conenmounts.com



PRODUCT FEATURES

- ◆ 2 electrical height adjustable columns, black anodized
- ◆ 500 mm / 19.7" height adjustment
- ◆ XL-floor plate made of 8 mm / 0.3" strong steel, powder-coated, RAL 9006 white aluminum
- ◆ XL-display mount for use with 70" – 120" display
- ◆ VESA 300 x 200 up to 1200 x 600
- ◆ Maximum load approximately 250 kg / 551.2 lbs
- ◆ Incl. wall brackets (70 mm / 2.8")

HIGHEST POSITION

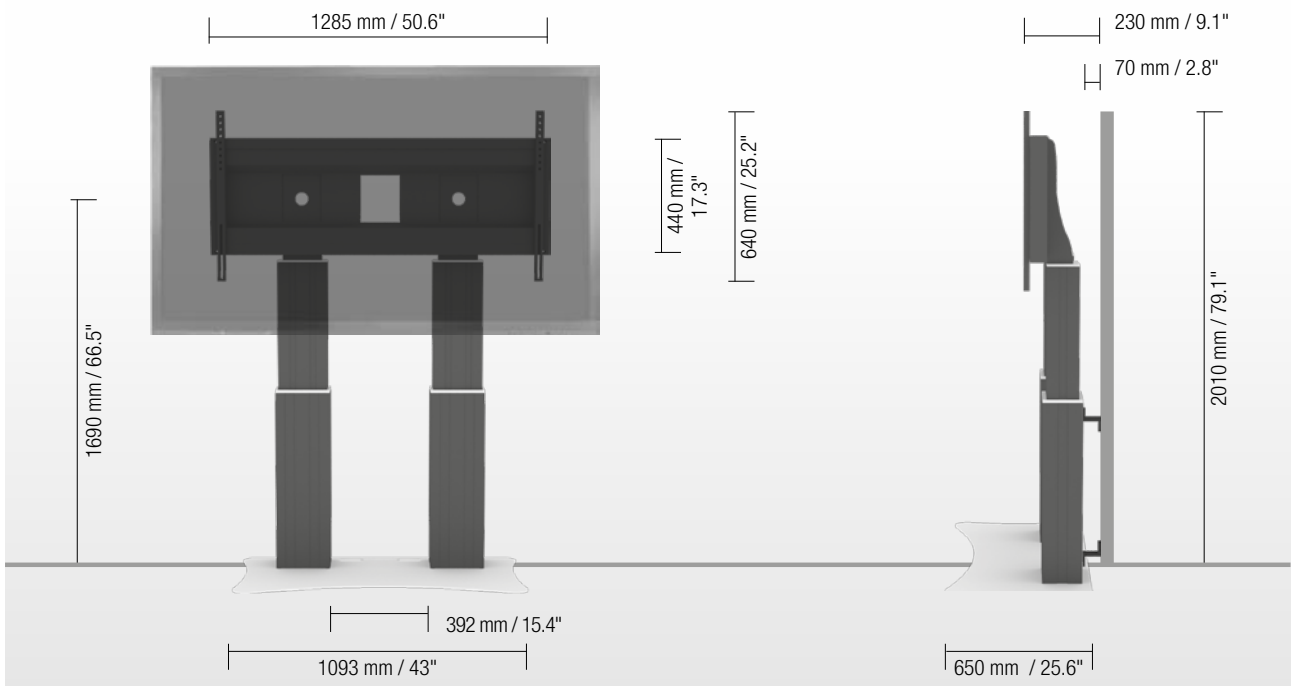

LOWEST POSITION

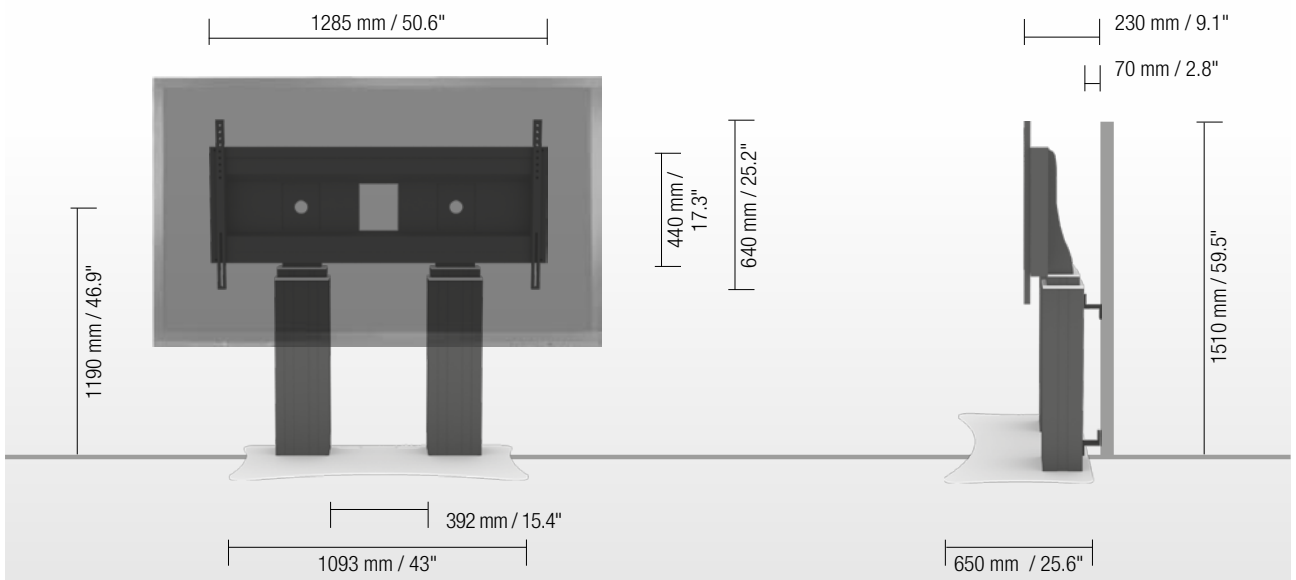

DETAIL VIEWS



Pull & release locking brackets for easier mounting of display



XL-floor plate



Wired remote control

AVAILABLE ACCESSORIES

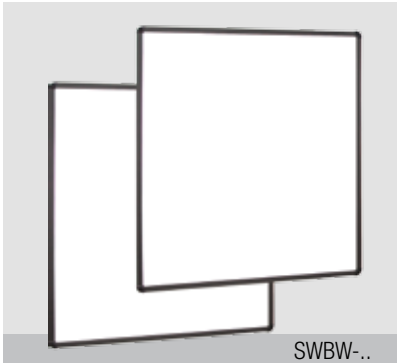

2 whiteboard side wings

SWBW-..



Side shelf

LAP4-..



Lockable mini PC bracket

MINI-FUJI



Video conference camera top shelf

VCTSCETA



Foot remote control

REM-FOOT



Extender (200 mm / 7.9")

CCE-EXT20



Display securing padlock

SCHLIESS-VH

SIZE INDEX

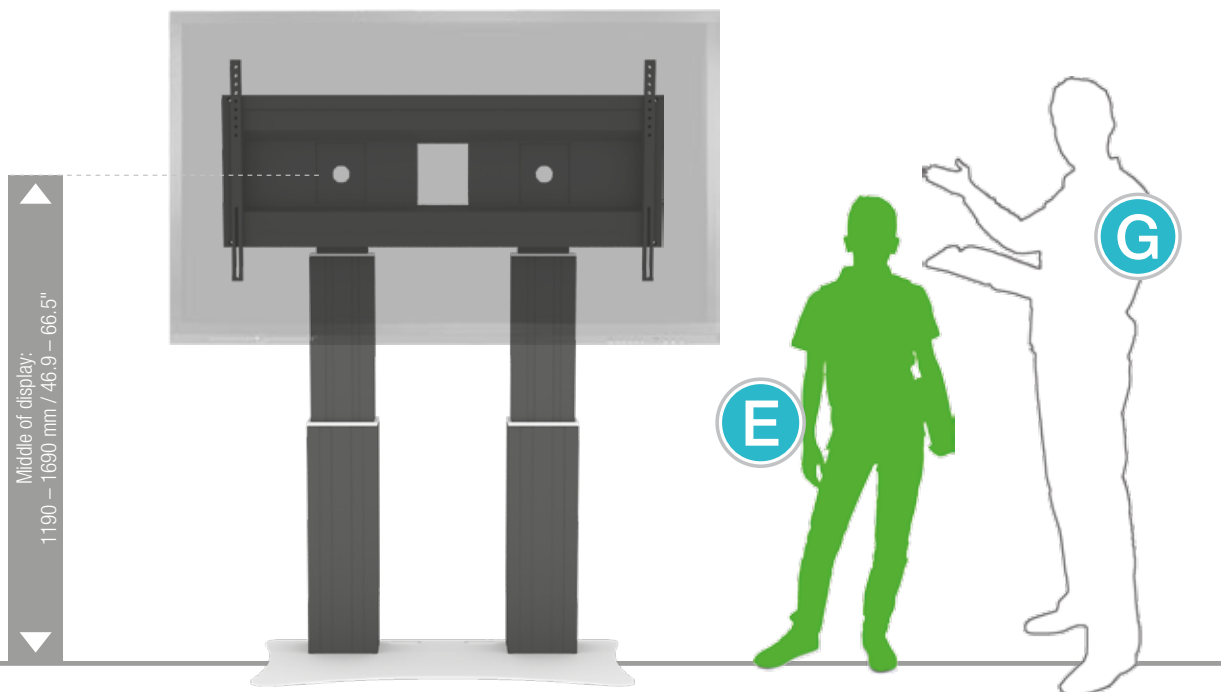

Department	Kindergarten				Primary school		Secondary school		Adults
	A	B	C	D	E	F	G		
Silhouette									
Age (years)	2 – 3	3 – 4	4 – 7	6 – 11	11 – 14	13 – 16	from 16		
Body size (mm / ")	930 – 980 37 – 38.6	1080 – 1210 42.5 – 47.6	1190 – 1420 46.9 – 56	1330 – 1590 52.4 – 62.6	1460 – 1765 57.5 – 69.5	1590 – 1880 62.6 – 74	1740 – 2070 68.5 – 81.5		
Color									

PACKING UNITS

Item no.	Description	Packing dimensions (mm / ")	Net weight (kg / lbs)	Gross weight (kg / lbs)
CCE70-WDB	2 x electrical height adjustable column, 500 mm / 19.7" height adjustment, L = 900 mm / 35.4"	2 x 1180 x 270 x 200 / 46.5 x 10.7 x 7.9	2 x 21 / 46.3	2 x 23,1 / 50.9
AFSCETAND	XL-display mount	1295 x 160 x 450 / 51 x 6.3 x 17.1	15 / 33.1	18 / 39.7
PSTSCETAD	XL-floor plate	30 x 750 x 800 / 1.2 x 29.5 x 31.5	30 / 1.2	32 / 1.3
Total weight			87 / 191.8	96,2 / 212.1