



SCETTACB

EL. HÖHENVERSTELL- & SCHRÄGSTELLBARES SYSTEM MIT C-FAHRGESTELL

EL. HEIGHT & TILT ADJUSTABLE SYSTEM WITH C-MOBILE STAND

Factory:

Conen Produkte GmbH & Co. KG
Conenstr. 4
54497 Morbach-Gonzerath
Germany

International sales department:

Mr. Luc van der Sterren
Office: +49 65 33 75 311
Cell: +31 612 495 098
Email: Luc@conenmounts.com

Mr. Arnaud Gielen
Office: +49 6533 75 310
Cell: +49 172 655 84 61
Email: Arnaud@conenmounts.com



PRODUKTEIGENSCHAFTEN | PRODUCT FEATURES

- ◆ Elektrisch höhenverstellbare Pylone, schwarz eloxiert
- ◆ 500 mm Hub
- ◆ Mobiles C-Fahrgestell mit vier Schwerlastrollen, davon zwei mit Feststellbremse, RAL 9005 Tiefschwarz
- ◆ Halterung zur Verwendung mit 42" – 70"/ 86" Display
- ◆ VESA 200 x 200 bis 800 x 600
- ◆ Maximale Belastung ca. 150 kg
- ◆ Electrical height adjustable column, black anodized
- ◆ 500 mm height adjustment
- ◆ C-shaped mobile stand with four heavy duty castors – two with brakes, RAL 9005 deep black
- ◆ Display mount for use with 42" – 70"/ 86" display
- ◆ VESA 200 x 200 up to 800 x 600
- ◆ Maximum load approximately 150 kg

HÖCHSTE STELLUNG | HIGHEST POSITION

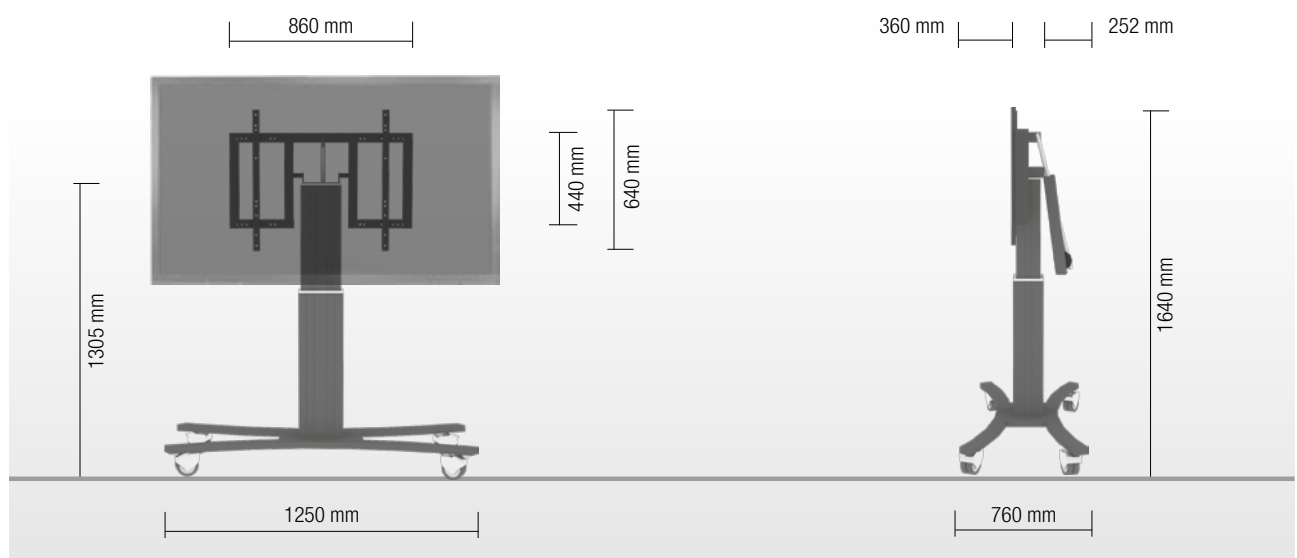

NIEDRIGSTE STELLUNG | LOWEST POSITION

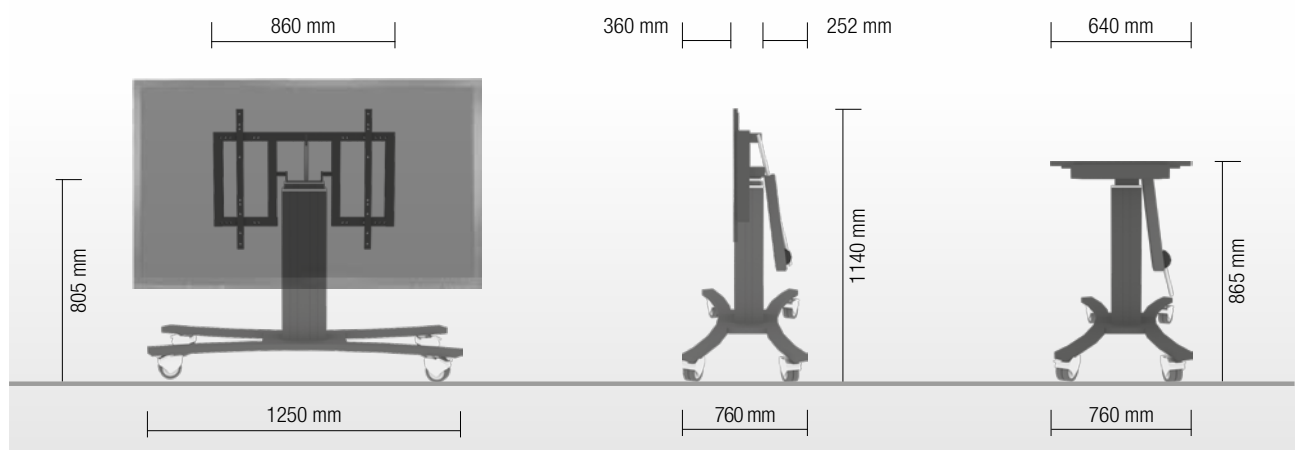

DETAILANSICHTEN | DETAIL VIEWS



Aushängesicherung
Screen secured by screws



Klappmechanismus
Tilt function



Leichtlaufende, feststellbare Rollen
Smooth running & lockable castors



Elektrische Fernbedienung
Wired remote control

WÄHLBARES ZUBEHÖR | AVAILABLE ACCESSORIES



LAP4-..

Seitentisch
Side shelf



FSH-..

Ablagetisch
Front shelf



MINI-FUJI

Abschließbare Mini-PC Halterung
Lockable mini PC bracket



CCE-EXT20

Verlängerung (200 mm)
Extender (200 mm)



LOCKSCETA

Abschließbare Wandhalterung
Lockable wall bracket



SCETA-ETH (C2-HB)

2 Boxenhalter (Boxen auf Anfrage)
2 box holders (boxes on request)

GRÖßENINDEX | SIZE INDEX

Mitte Display | Middle of display
805 – 1305 mm

Tischmodus | Table mode:
865 – 1365 mm

Bereich | Department

	Kindergarten				Grundschule Primary school		Erwachsene Adults
				Weiterführende Schule Secondary school			

Silhouette | Silhouette

	A	B	C	D	E	F	G
--	----------	----------	----------	----------	----------	----------	----------

Alter (Jahre) | Age (years)

	2 – 3	3 – 4	4 – 7	6 – 11	11 – 14	13 – 16	ab from 16
--	-------	-------	-------	--------	---------	---------	--------------

Körpergröße | Body size (mm)

	930 – 980	1080 – 1210	1190 – 1420	1330 – 1590	1460 – 1765	1590 – 1880	1740 – 2070
--	-----------	-------------	-------------	-------------	-------------	-------------	-------------

Farbe | Colour

	Green	Purple	Yellow	Red	Light Green	Blue	White
--	-------	--------	--------	-----	-------------	------	-------

PACKEINHEITEN | PACKING UNITS

Artikel-Nr. Item no.	Beschreibung Description	Packmaße Packing dimensions (mm)	Nettogewicht Net weight (kg)	Bruttogewicht Gross weight (kg)
CCET-50B	Elektrisch höhenverstellbare Pylone, 500 mm Hub, L = 700 mm Electrical height adjustable column, 500 mm height adjustment, L = 700 mm	970 x 280 x 220	19,5	22,1
AF-SCETTA	Display Halterung Display mount	890 x 770 x 480	22,1	26,8
MST-SCETA-CB	C-Fahrgestell C-shaped mobile stand	1350 x 780 x 120	12,8	15,5
Gesamtgewicht Total weight			54,4	64,4



SCETTACB

EL. HEIGHT & TILT ADJUSTABLE SYSTEM WITH C-MOBILE STAND

Factory:

Conen Produkte GmbH & Co. KG
Conenstr. 4
54497 Morbach-Gonzerath
Germany

International sales department:

Mr. Luc van der Sterren
Office: +49 65 33 75 311
Cell: +31 612 495 098
Email: Luc@conenmounts.com

Mr. Arnaud Gielen
Office: +49 6533 75 310
Cell: +49 172 655 84 61
Email: Arnaud@conenmounts.com



PRODUCT FEATURES

- ◆ Electrical height adjustable column, black anodized
- ◆ 500 mm / 19.7" height adjustment
- ◆ C-shaped mobile stand with four heavy duty castors – two with brakes, RAL 9005 deep black
- ◆ Display mount for use with 42" – 70" / 86" display
- ◆ VESA 200 x 200 up to 800 x 600
- ◆ Maximum load approximately 150 kg / 330.7 lbs

HIGHEST POSITION

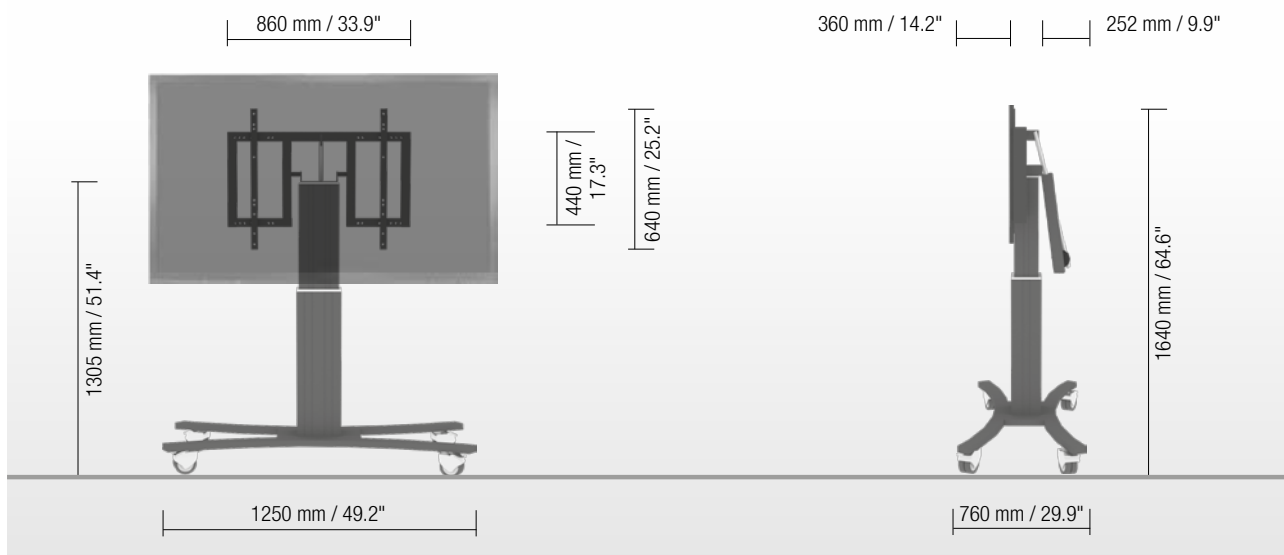

LOWEST POSITION

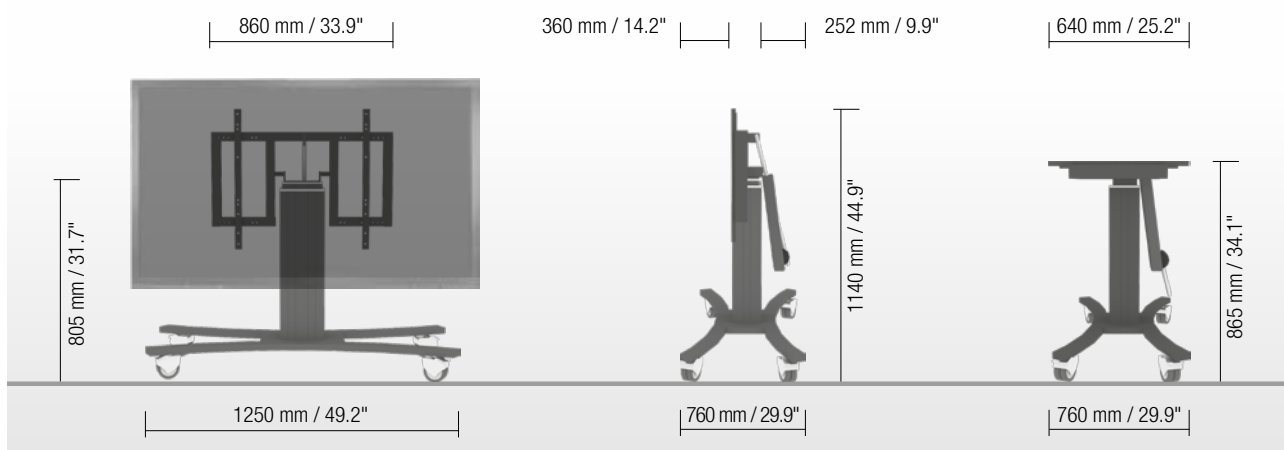

DETAIL VIEWS



Screen secured by screws



Tilt function



Smooth running & lockable castors



Wired remote control

AVAILABLE ACCESSORIES



LAP4-..

Side shelf



FSH-..

Front shelf



MINI-FUJI

Lockable mini PC bracket



CCE-EXT20

Extender (200 mm / 7.9")



LOCKSCETA

Lockable wall bracket



SCETA-ETH (C2-HB)

2 box holders (boxes on request)

SIZE INDEX

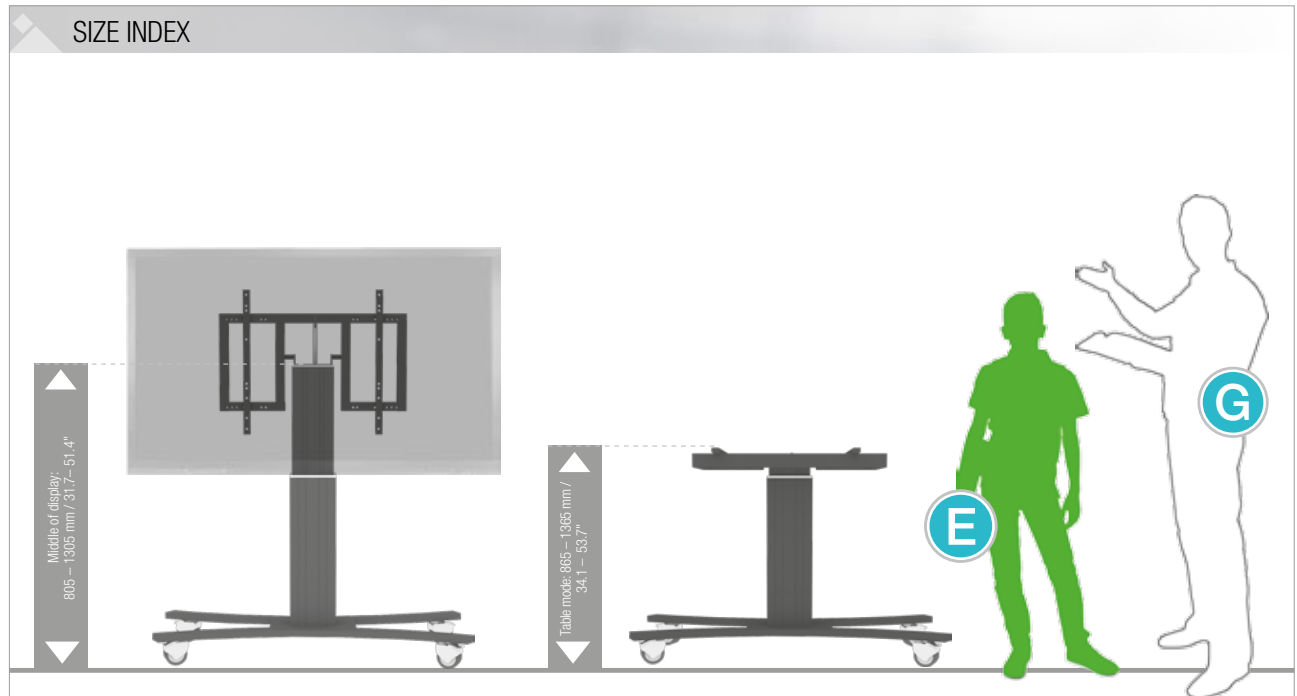

Department	Kindergarten			Primary school		Secondary school		Adults
	A	B	C	D	E	F	G	
Age (years)	2 - 3	3 - 4	4 - 7	6 - 11	11 - 14	13 - 16	from 16	
Body size (mm / ")	930 - 980 37 - 38.6	1080 - 1210 42.5 - 47.6	1190 - 1420 46.9 - 56	1330 - 1590 52.4 - 62.6	1460 - 1765 57.5 - 69.5	1590 - 1880 62.6 - 74	1740 - 2070 68.5 - 81.5	
Color								

PACKING UNITS

Item no.	Description	Packing dimensions (mm / ")	Net weight (kg / lbs)	Gross weight (kg / lbs)
CCET-50B	Electrical height adjustable column, 500 mm / 19.7" height adjustment, L = 700 mm / 27.6"	970 x 280 x 220 / 38.2 x 11 x 8.7	19,5 / 43	22,1 / 48.7
AF-SCETTA	Display mount	890 x 770 x 480 / 35 x 30.3 x 18.9	22,1 / 48.7	26,8 / 59,1
MST-SCETA-CB	C-shaped mobile stand	1350 x 780 x 120 / 53.1 x 30.7 x 4.7	12,8 / 28.2	15,5 / 28.2
Total weight			54,4 / 119.9	64,4 / 142