

LINDY®

CONNECTION PERFECTION

8 Port Nway Gigabit Ethernet Switch

User Manual

English



LINDY No. 25045



www.LINDY.com

Introduction

This switch provides 8 10/100/1000M ports. It was designed for easy installation and high performance in an environment where traffic is on the network and the number of users increases continuously.

The small compact palm size was specifically designed for small to medium workgroups. It can be installed where space is limited; moreover, it provides smooth network migration and easy upgrade to network capacity.



Package Contents

Before you start to install this switch, please verify your package that contains the following items:

- One Gigabit Ethernet Switch
- One Power Adapter
- One User's Manual

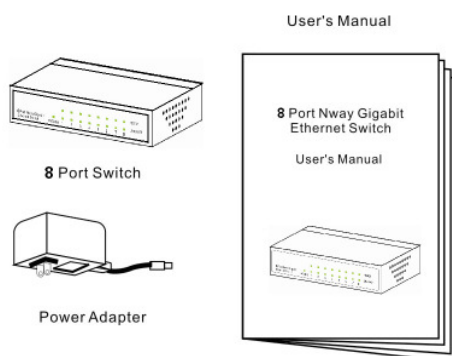

Note: If any of these items is found missing or damaged, please contact your local supplier for replacement.

Key Features

- 8 Port 10/100/1000M Nway (Auto-negotiation) Switch
- Palm size with metal case
- Auto-learn of networking configurations
- Auto-detect full/half-duplex modes for any port
- Dedicated full-duplex 2000Mbps bandwidth
- Store-and-Forward switching methods
- IEEE 802.3x flow control for full-duplex and back-pressure flow control for half-duplex
- Non-blocking & Non-head-of-line blocking full wire speed forwarding
- Auto-MDI/MDI-X function for any port
- Smart plug & play

Power

Power is supplied through an external DC power adapter.

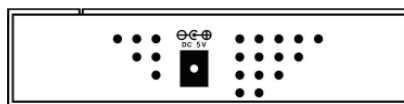

Front Panel (LEDs)

LED Indicators of 8 Port 10/100/1000M Switch

LED	Status	Operation
Power	On	Power is on.
	Off	Power is off.
LINK/ACT	On	Port is for connection
	Off	No connection.
	Flashing	Data is transmitted or received.
1000M	On	Port is on 1000M status
	Off	Port is on 10/100M status.

Rear Panel (Connections)

Switch/Hub to this 8 Port Gigabit Ethernet Switch

This switch provides automatic crossover detection functionality for any port. It is simple and friendly to up-link to another switch without crossover cable.

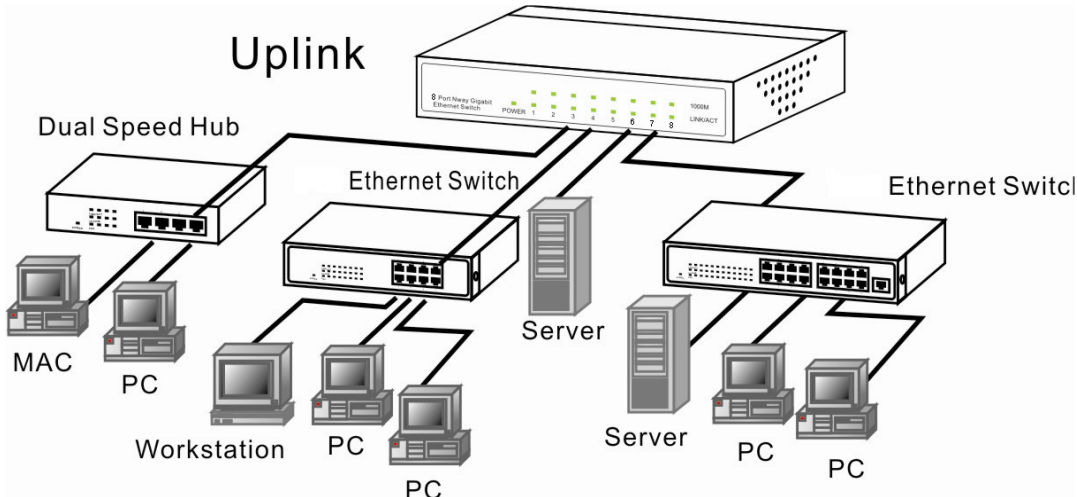

PC/Other devices to this 8 Port Gigabit Ethernet Switch

Via a twisted pair cable straight through, this switch can be connected to PCs, servers and other network devices.

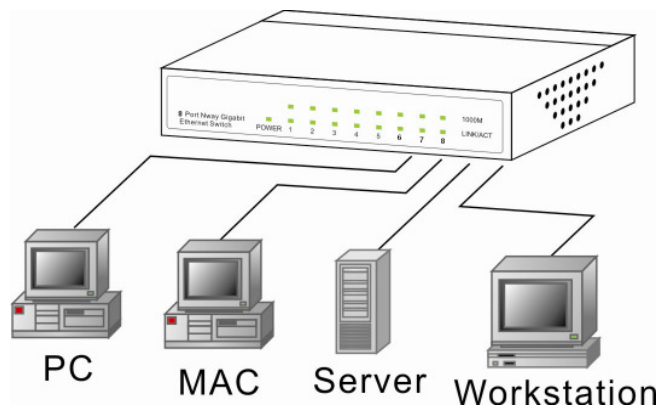

Technical Specifications

Standards	IEEE 802.3 10BaseT IEEE 802.3u 100BaseTX IEEE 802.3ab 1000BaseT IEEE 802.3x Flow control
Features	Number of Ports: 8 MAC Address: 4K Buffer Memory: 128 KB Jumbo Frames: 9KB Transmission Method: Store and Forward
Filtering/Forwarding Rates	1000Mbps port – 1,488,000pps 100Mbps port – 148,800pps 10Mbps – 14,880pps
Transmission Media	10BaseT Cat. 3, 4, 5 UTP/STP 100BaseTX Cat. 5 UTP/STP 1000BaseT Cat. 5E UTP/STP
LED Indicators	Per Port: LINK/ACT, 1000M Per Unit: Power
Power Supply	DC 5V/2A
Power Consumption	7 Watts (Max)
Dimensions	130 x 97 x 24 mm (L x W x H)
Weight	0.40 kg
Operating Temperature	0 to 55°C
Storage Temperature	-20 to 90°C
Humidity	10 to 90% RH (non-condensing)
Certifications	FCC Class B, CE

Radio Frequency Energy, Certifications

FCC Warning

This equipment has been tested and found to comply with the limits for a Class B Digital device, pursuant to part 15 of the FCC Rules. These limits are designed to provide reasonable protection against harmful interference in a residential installation. This equipment generates, uses, and can radiate radio frequency energy and, if not installed and used in accordance with the instructions, may cause harmful interference to radio communications. However, there is no guarantee that interference will not occur in a particular installation. If this equipment does cause harmful interference to radio or television reception, which can be determined by turning the equipment off and on, the user is encouraged to try to correct the interference by one or more of the following measures:

- Reorient or relocate the receiving antenna
- Increase the separation between the equipment and receiver
- Connect the equipment into an outlet on a circuit different from that to which the receiver is connected
- Consult the dealer or an experienced technician for help

You are cautioned that changes or modifications not expressly approved by the party responsible for compliance could void your authority to operate the equipment.

CE Statement, EMC Compatibility

This device complies with EN Standards EN55022 and EN55024 according to the relevant EC EMC Directive. It must be used with shielded cables only to maintain EMC compatibility.

Dieses Produkt entspricht den einschlägigen EMV Richtlinien der EU und darf nur zusammen mit abgeschirmten Kabeln verwendet werden.

LINDY Herstellergarantie

LINDY gewährt für dieses Produkt über die gesetzliche Regelung hinaus eine zweijährige Herstellergarantie ab Kaufdatum. Die detaillierten Bedingungen dieser Garantie finden Sie auf der LINDY Website aufgelistet bei den AGBs.



WEEE (Waste of Electrical and Electronic Equipment), Recycling of Electronic Products

In 2006 the European Union introduced regulations (WEEE) for the collection and recycling of all waste electrical and electronic equipment. The wheeled bin symbol shown indicates that this product must not be disposed of with household waste. Instead the product must be recycled in a manner that is environmentally friendly. For more information on how to dispose of this product, please contact your local recycling centre or your household waste disposal service. Each individual EU member state has implemented the WEEE regulations into national law in slightly different ways. Please follow your national law when you want to dispose of any electrical or electronic products.

More details can be obtained from your national WEEE recycling agency.

Germany / Deutschland

Die Europäische Union hat mit der WEEE Richtlinie umfassende Regelungen für die Verschrottung und das Recycling von Elektro- und Elektronikprodukten geschaffen. Diese wurden von der Bundesregierung im Elektro- und Elektronikgerätegesetz – ElektroG in deutsches Recht umgesetzt. Dieses Gesetz verbietet vom 24. März 2006 an das Entsorgen von Elektro- und Elektronikgeräten über die Hausmülltonne! Diese Geräte müssen den lokalen Sammelsystemen bzw. örtlichen Sammelstellen zugeführt werden! Dort werden sie kostenlos entgegen genommen. Die Kosten für den weiteren Recyclingprozess übernimmt die Gesamtheit der Gerätehersteller.

LINDY No 25045



1st Edition, July 2009
www.lindy.com