

EN  **Caution**

1. To ensure safety, please read this manual carefully before installation and follow the instructions. Store this manual in a secure place for future reference.
2. The manufacturer shall not be legally responsible for any equipment damage or personal injury caused by incorrect installation or operation other than that covered in this manual.
3. The mount is designed for easy installation and removal. The manufacturer shall not be liable for damage to equipment or personnel injuries arising out of human factors or acts of God, such as earthquake or typhoon.
4. It is recommended that the Wall mount bracket be installed by qualified personnel only
5. At least two persons are needed to install or remove the product to avoid hazard of falling objects.
6. Please carefully inspect the area where the wall mount is to be installed:
 - Avoid places that are subject to high temperatures, humidity or contact with water.
 - Do not install the product near air conditioning vents or areas with excess dust and fumes.
 - Only install on vertical walls and avoid slanted surfaces.
 - Do not install in places subject to any shock or vibration.
 - Do not install in places subject to direct exposure to bright light, it may cause eye fatigue when viewing the display panel.
7. Maintain sufficient space around the display to ensure adequate ventilation.
8. To ensure safe installation, first check the structure of the wall and select a secure mounting location.
9. The wall should be strong enough to sustain a weight of at least four times of the display and Wall mount bracket combined. The mounting location must be able to withstand earthquake or other strong shock.
10. Do not modify any accessories or use broken parts. Contact your dealer with any questions.
11. Tighten all screws (do not exert excessive force to avoid breaking the screw or damaging its thread).
12. Drill holes and bolts will be left in the wall once the display and Wall mount bracket are removed. Stains may occur after extended use.
13. Since the manufacturer has no way to control the wall type and installation of wall mount, the warranty of the product shall only cover the body of the wall mount. The warranty period of the product is 5 years.
14. Please consult the English language manual for any dispute on conditions.

FR  **Attention**

1. Afin d'assurer votre sécurité, nous vous prions de bien lire le manuel avant l'installation et de suivre attentivement les instructions qui y sont incluses. Conservez ce manuel dans un endroit sûr comme référence.
2. Le fabricant ne sera tenu légalement responsable d'aucun dommage à l'équipement ou de blessure corporelle causés par une mauvaise installation ou utilisation de l'équipement autre que celle décrite au sein du présent manuel.
3. Le support de fixation murale est conçu de façon à faciliter l'installation et le déplacement. Le fabricant ne sera tenu responsable d'aucun dommage à l'équipement ou de blessure corporelle découlant d'erreur humaine ou de cas de force majeure, tels un tremblement de terre ou un typhon.
4. Il est recommandé de ne permettre qu'à du personnel qualifié d'installer le support de fixation murale.
5. L'installation ou le déplacement du produit doit être accompli par un minimum de deux personnes afin d'éviter les dangers potentiels causés par une chute.
6. Nous vous prions d'inspecter soigneusement l'emplacement où le support de fixation murale sera installé:
 - N'installez pas le produit près de bouches d'air climatisé ou dans des endroits avec beaucoup de poussière ou de vapeurs toxiques.
 - N'installez pas le produit près de bouches d'air climatisé ou dans des endroits avec beaucoup de poussière ou de vapeurs toxiques.
 - N'installez que sur des murs verticaux et évitez les surfaces inclinées.
 - N'installez pas dans des endroits avec des chocs ou des vibrations.
 - N'installez pas dans endroits exposés à des lumières fortes, cela pourrait causer la fatigue visuelle lors de l'observation du panneau d'affichage.
7. Laissez un espace suffisant autour de l'écran pour une ventilation adéquate.
8. Afin d'assurer la sécurité et la prévention des accidents, il est impératif de vérifier la structure du mur et de choisir un endroit solide avant de l'installer.
9. Le mur devrait être assez suffisamment fort pour soutenir un poids quatre fois supérieur à celui du poids combiné de l'écran et du support de fixation murale ensemble. L'emplacement du montage doit pouvoir survivre à un tremblement de terre ou autre choc intense.
10. Ne modifiez aucun accessoire ni utilisez des composants détériorés. Contactez votre distributeur si vous avez des questions.
11. Serrez toutes les vis (n'utilisez pas de force excessive pour éviter d'abîmer les vis ou le filetage).
12. Les trous de perçage et les écrous resteront dans le mur lorsque vous déplacerez l'écran et le support de fixation murale. Des taches peuvent apparaître après une longue utilisation.
13. Puisque le fabricant ne peut en aucun cas contrôler le type de mur et la qualité de l'installation du support de fixation murale, la garantie du produit ne couvre que le support de fixation murale. La durée de la garantie est de 5 ans.

DE  **Vorsicht**

1. Lesen Sie bitte vor der Installation das Handbuch sorgfältig durch und befolgen allAen weisungen, um die Sicherheit zu gewähren. Heben Sie das Handbuch auf, damit Sie später darin nachlesen können.
2. Der Hersteller haftet für keine Geräte- oder Personenschäden, die durch unsachgemäße Installation oder Bedienung, die nicht in diesem Handbuch beschrieben ist, entstanden sind.
3. Die Wandmontage ist für eine einfache Installation und Demontage ausgelegt. Der Hersteller haftet nicht für Geräte- oder Personenschäden, die durch menschliche Faktoren oder höhere Gewalt, wie z.B. Erdbeben oder Orkan entstanden sind.
4. Wir empfehlen Ihnen die Wandhalterung nur von einem qualifiziertenT echniker installieren zu lassen.
5. Die Installation oder Demontage des Produkts muss von mindestens zwei Personen ausgeführt werden, um die Gefa, hrrass Gegenstände herunterfallen, zu vermeiden.
6. Bitte überprüfen Sie sorgfältig die Stelle, wo das Wandmontageset installiert wird:
 - Vermeiden Sie Stellen mit hohen Temperaturen oder Feuchtigkeit bzw. Stellen, die mit Wasser in Kontakt kommen können.
 - Installieren Sie das Produkt nicht in der Nähe von Klimaanlageöffn ungen oder an einer Stelle, wo es übermäßig Staub und Rauch gibt.
 - Montieren Sie das Produkt nur an eine vertikale Wand. Vermeiden Sie schräge Oberflächen.
 - Installieren Sie das Produkt nicht an einer Stelle, an denen es Erschütterungen oder Schwingungen ausgesetzt ist.
 - Installieren Sie das Produkt nicht an einer Stelle mit direkter Sonneneinstrahlung bzw. starkem Licht. Dies fördert beim Anschauen derBildschirmanzeige das Ermüden der Augen.
7. Halten Sie um das Anzeigergerät ausreichend Freiraum, um eine gute Belüftung zu gewähren.
8. Um die Sicherheit zu gewähren und Unfälle zu vermeiden, ist es notwendig, vor der Installation die aWndstruktur zu überprüfen bzw. eine sichere Stelle auszuwählen.
9. Die Wand muss stark genug sein, um ein Gewicht von mindestens dem Vierfachen des Gesamtgewichts des Anzeigergerätes und des Wandmontagesets zu tragen. Der Montageort muss in der Lage sein, Erdbeben oder sonstige starke Erschütterungen standzuhalten.
10. Modifizieren Sie keine Zubehöerteile. Verwenden Sie keine beschädigten Teile. Wenden Sie sich an Ihren Händler, wenn Sie Fragen haben.
11. Ziehen Sie alle Schrauben fest. (Wenden Sie nicht zu viel Kraft an, um ein Brechen der Schraube oder Beschädigen des Gewindes zu vermeiden.)
12. Die Bohrungen und die Schrauben bleiben an der Wand sichtbar, wenn das Anzeigergerät und das Wandmontageset entfernt wird. Nach längerem Gebrauch kann ein Fleck an der Wand bleiben.
13. Der Hersteller hat keinen Einfluss auf den Wandtyp und die Installation des Wandmontagesets. Deshalb deckt die Garantie des Produkts nur das Wandmontageset selbst ab. Die Garantie des Produkts gilt für 5 Jahre.
14. Bitte ziehen Sie die englische Version des Handbuchs zu Rate, falls es Unstimmigkeiten hinsichtlich der Bedingungen gibt.

ES  **Precaución**

1. Para garantizar su seguridad, lea este manual detenidamente antes de la instalación y siga sus instrucciones. Conserve este manual en un lugar seguro para futuras consultas.
2. El fabricante no será legalmente responsable de ningún daño producido sobre el equipo o lesión personal causada por una instalación o uso no mencionado explícitamente en este manual.
3. El soporte de pared ha sido diseñado para instalar y retirar fácilmente el dispositivo. El fabricante no se hace responsable de los daños provocados sobre el equipo o las lesiones personales que se deriven de factores humanos o actos de fuerza mayor, como un terremoto o un tifón.
4. Se recomienda que el soporte de pared sea instalado por personal cualificado.
5. Para evitar que se caiga el producto, la instalación o retirada deberá ser realizada por al menos dos personas.
6. Inspeccione detenidamente el área en el que desea instalar el soporte de pared:
 - Evite los lugares sometidos a altas temperaturas, alto nivel de humedad, o que se encuentren en contacto con el agua.
 - No instale el producto cerca de un orificio de aire acondicionado, o en zonas con gran cantidad de polvo o humos.
 - Instale el producto en una pared vertical. Evite las superficies sesgadas.
 - No instale el producto en lugares sujetos a golpes o vibraciones.
 - No instale el producto en lugares en los que se encuentre expuesto a luces muy brillantes. Ello podría provocar fatiga ocular al mirar el panel de pantalla.
7. Mantenga espacio libre suficiente alrededor de la pantalla para asegurar su adecuada ventilación.
8. Para garantizar su seguridad y evitar accidentes, compruebe la estructura de la pared y seleccione un emplazamiento seguro antes de la instalación.
9. La pared debe tener fuerza suficiente para soportar un peso de al menos cuatro veces la pantalla y el soporte en conjunto. El lugar de montaje debe ser capaz de aguantar terremotos u otros golpes fuertes.
10. No modifique ningún accesorio ni utilice componentes deteriorados. Póngase en contacto con su distribuidor si tiene alguna duda.
11. Apriete todos los tornillos (no ejerza demasiada fuerza para evitar que se roma el tornillo o se dañe la rosca).
12. Mantenga los orificios y los pernos en la pared después de retirar la pantalla y el soporte de pared. Podrían quedar manchas después de un uso prolongado.
13. Dado que el fabricante no dispone de ningún método para comprobar el tipo de pared e instalación del soporte, la garantía del producto cubre únicamente el soporte de pared en sí. El periodo de garantía de este producto es de 5 años.
14. Consulte el manual en inglés si tiene alguna duda acerca de las condiciones.

IT  **Attenzione**

1. Per garantire la sicurezza, leggere attentamente questo manuale prima di effettuare l'installazione e seguire le istruzioni qui contenute. Conservare questo manuale in un luogo sicuro per riferimenti futuri.
2. Il produttore non deve essere ritenuto responsabile legalmente per qualsiasi danno all'apparecchio o lesione alla persona provocati da installazione non corretta o funzionamento diverso da quello riportato nel seguente manuale.
3. Il montaggio a parete è stato ideato per una facile installazione e rimozione. Il produttore non sarà responsabile per danni all'apparecchio o per lesioni alla persona derivanti da fattori umani o eventi naturali, come tifoni o terremoti.
4. Si consiglia di far installare la staffa per il montaggio a parete solo da personale qualificato.
5. Per installare o rimuovere il prodotto sono necessarie almeno due persone per evitare rischi o la caduta di oggetti.
6. Controllare attentamente l'area dove va effettuato il montaggio:
 - Evitare luoghi soggetti a temperature alte, umidità o contatto con l'acqua.
 - Non installare il prodotto accanto a uscite di ventilazione o aree con polvere o fumi eccessivi.
 - Installare solo su pareti verticali, evitare superfici inclinate.
 - Non installare in luoghi soggetti a urti o vibrazioni.
 - Non installare in luoghi soggetti a esposizione diretta alla luce, in quanto si potrebbe provocare fastidiosamente agli occhi durante la visualizzazione del pannello.
7. Mantenere spazio sufficiente intorno al monitor per garantire una adeguata ventilazione.
8. Per garantire la sicurezza e per prevenire incidenti, è necessario, prima di eseguire l'installazione, controllare la struttura della parete e scegliere un posizionamento sicuro.
9. La parete deve essere abbastanza forte per sostenere almeno quattro volte il peso del monitor e della staffa per il montaggio insieme. Il punto di montaggio deve essere in grado di sopportare terremoti o urti forti.
10. Non modificare gli accessori o utilizzare parti rotte. Contattare il rivenditore per qualsiasi domanda.
11. Stringere tutte le viti (non applicare forza eccessiva per evitare la rottura delle viti o il danneggiamento della filettatura).
12. Fori e bulloni possono essere lasciati sulla parete una volta rimossi la staffa e il monitor. Dopo un periodo prolungato di utilizzo, possono formarsi delle macchie.
13. Dato che il produttore non ha alcun modo di controllare il tipo di parete e l'installazione, la garanzia del prodotto coprirà esclusivamente il corpo della struttura per il montaggio. Il periodo di garanzia del prodotto è di 5 anni.
14. Consultare il manuale in lingua inglese per eventuali controversie sulle condizioni.

NEWSTAR

AV & IT MOUNTS



MED-M200

- | | | | |
|---|------------------------------------|---|-------------------------------------|
|  | Medical screen mount |  | Medische monitor steun |
|  | Medical Display Halterung |  | Support médical pour écran |
|  | Supporto medico per schermo |  | Soporte para pantalla medica |
|  | Suporte para ecrã médico |  | Medicinske skærmeslag |
|  | Sairaalaa näyttöjen teline |  | Fäste för medicinska skärmar |
|  | Medisinske skjermfeste |  | Uchwył medyczny monitora |

MED-M200

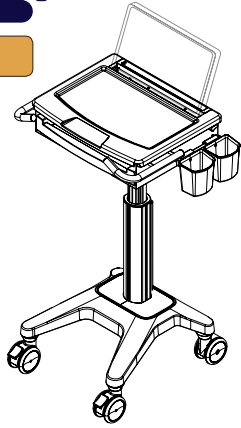

Index

Features-----	p2
Adjustment direction-----	p3
Checklist-----	p3
Assembly instruction-----	p4
Cart's adjustment and operation-----	p7
Summary of warnings-----	p8
Maintenance-----	p10
Troubleshooting-----	p11



5 kg

Features

1. Laptop compartment
2. Storage basket
3. Work surface
4. Lift brake release (release brake to raise or lower the cart)
5. Cable management
6. Sliding keyboard tray with mouse holder and sliding mouse tray (to accommodate both right and left hand users)
7. Casters (2 rear non-locking and 2 front locking)
8. Latch
9. Key and lock hole
10. Hanger for accessories
11. Track for accessories mounted

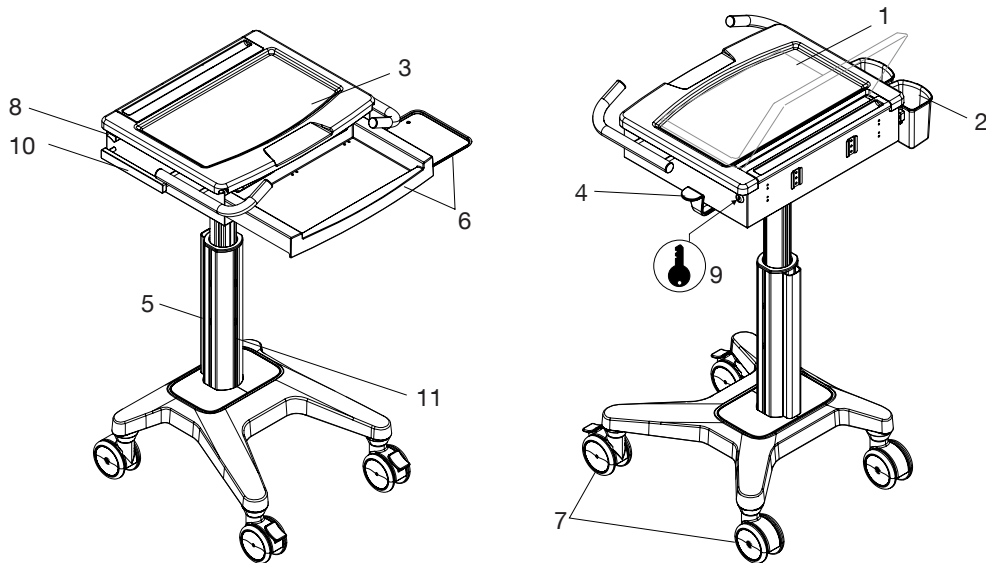

Adjustment direction

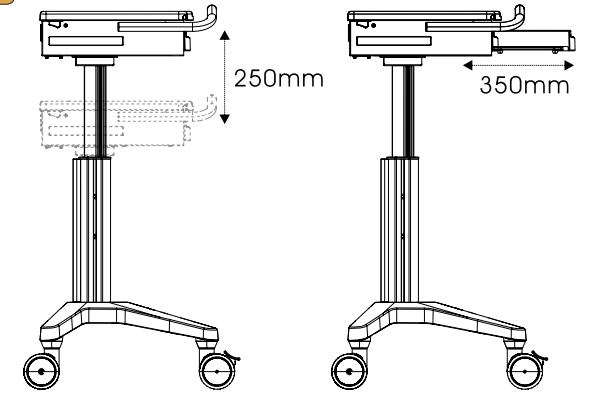

Checklist

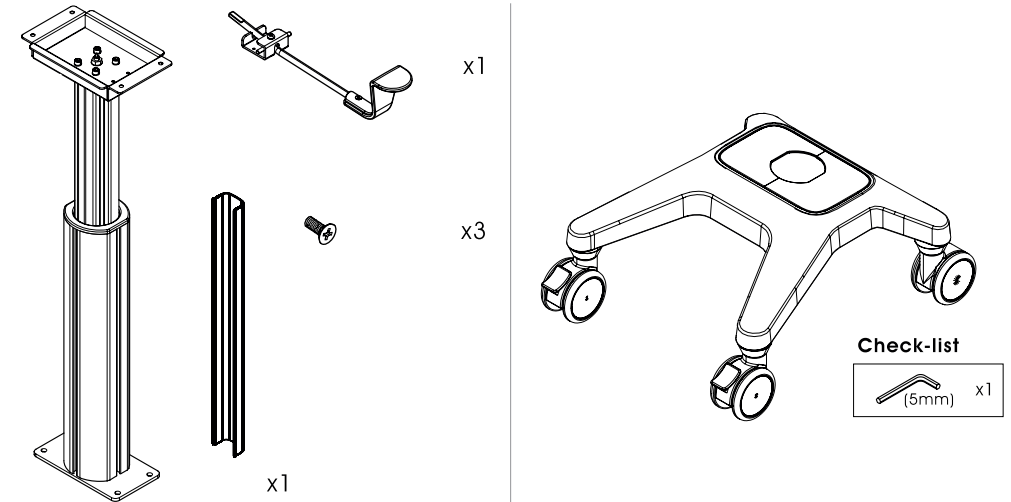
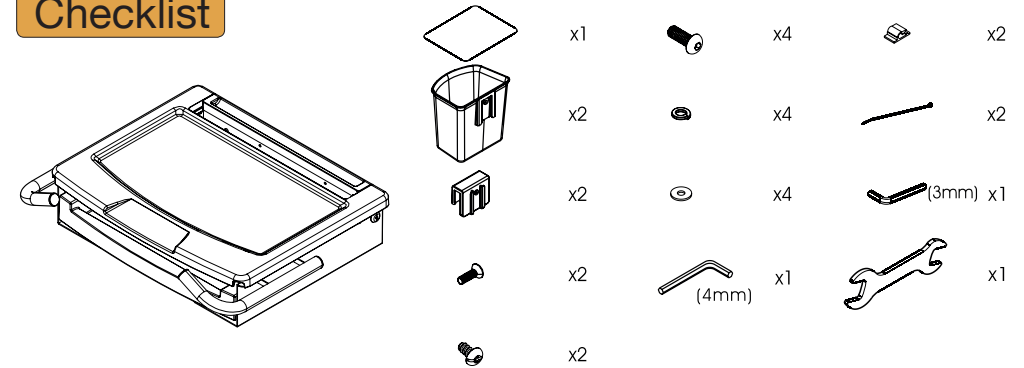

Assembly instruction

Step 1

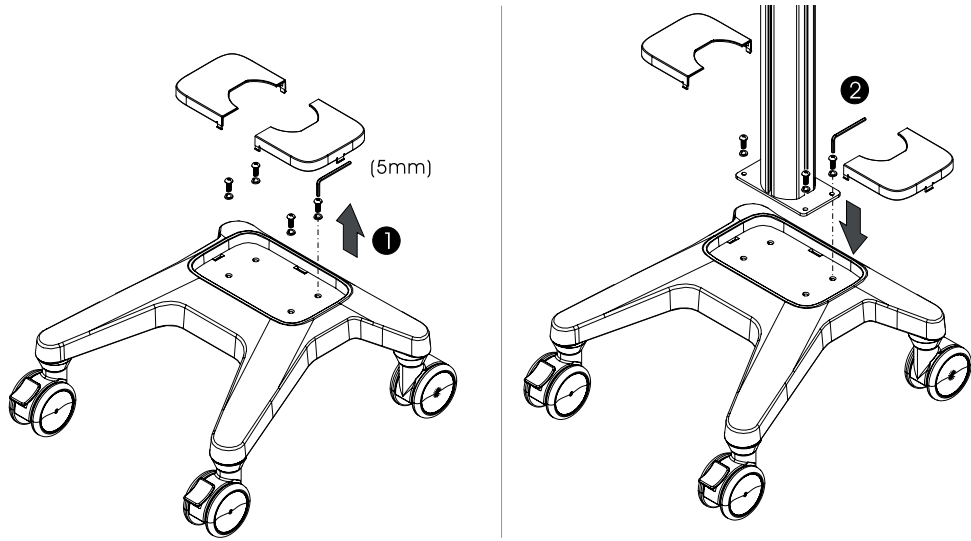

Step 3

(1) Unlock the work surface by turning the key counterclockwise.

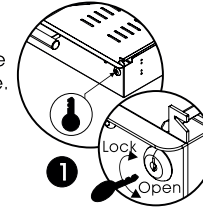

(2) Push the latch backward to lift the work surface.

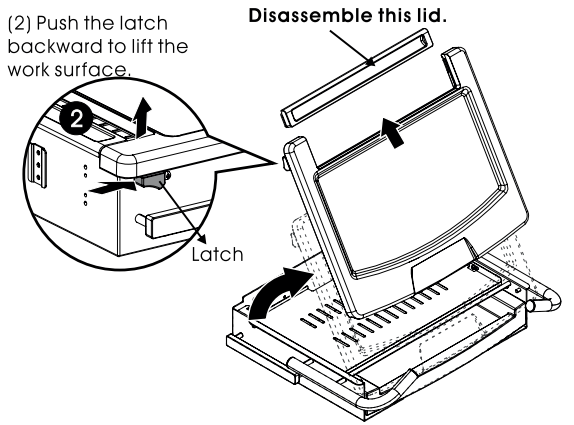

Step 2

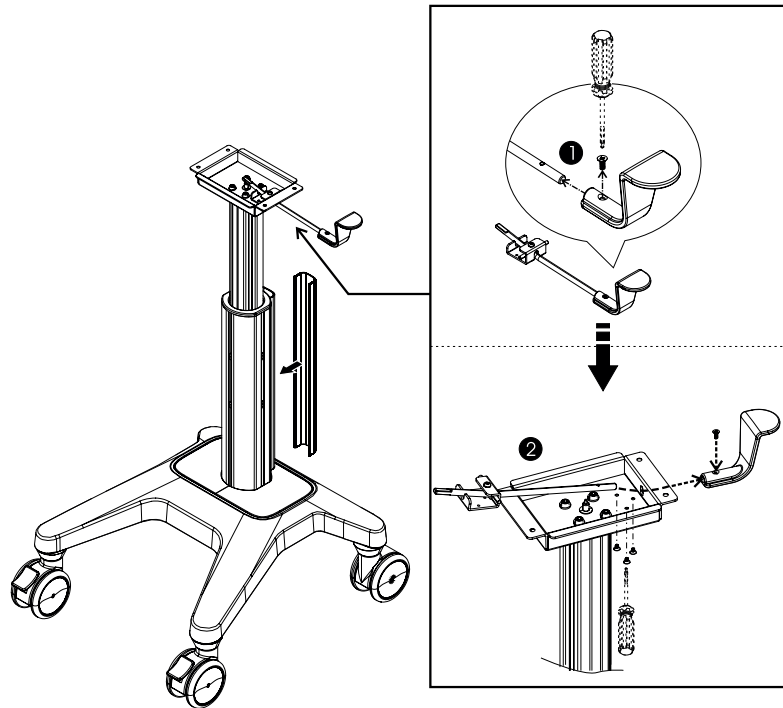

Step 4

Use a 4mm allen key to loose the screw. Push the cooling pad forward to take it out.

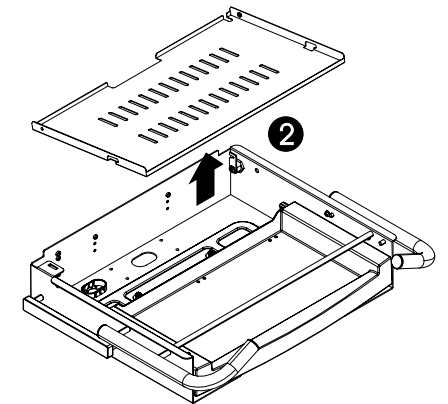
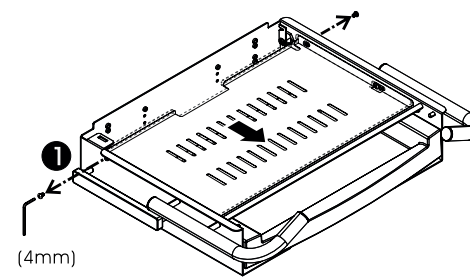

Step 5

Use the screws to combine the top plate and the middle pillar.

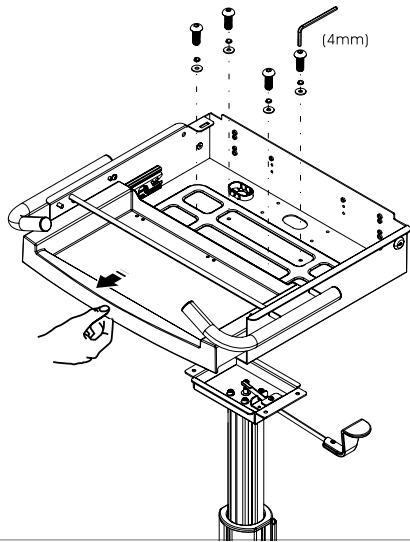

Step 6

Storage basket can be placed as different demands.

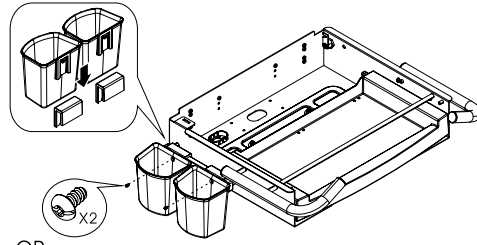

OR

Slide a storage basket into the back side of cart.

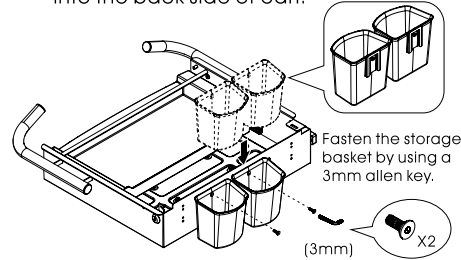

Fasten the storage basket by using a 3mm allen key.

(3mm)

X2

Step 8

Put back the cooling pad and fasten the screws by using a 4mm allen key.

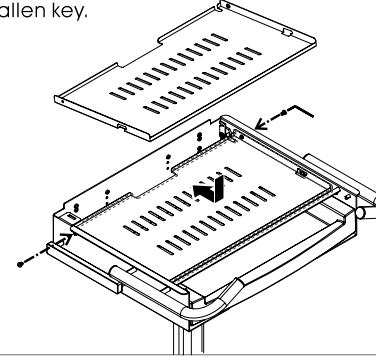

Set the laptop into the compartment and then replace the work surface. Please notice the work surface must be locked and latch must be pushed forward before moving this cart.

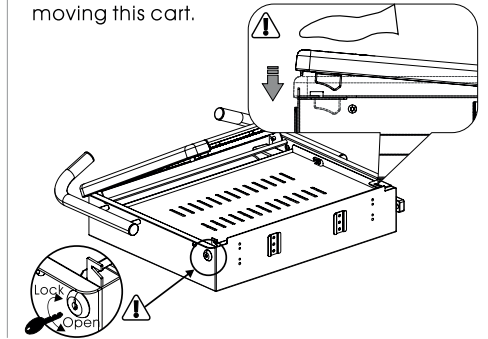

Cart's adjustment and operation



In case of users harm or cart damage, do not adjust lift mechanism with an empty cart which may cause work surface to rise speedily.

Notice:

While releasing brake to move the height of work surface riser or lower, please put two hands on two sides of work surface as figure. Do not push the center of work surface for lower adjustment. Please use two hands to uphold slightly for riser adjustment if the work surface is still motionless.

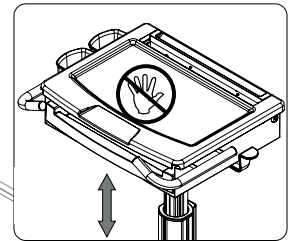

Step 7

Direction of cable management and accessory assembly

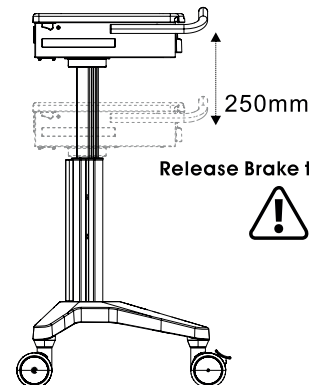
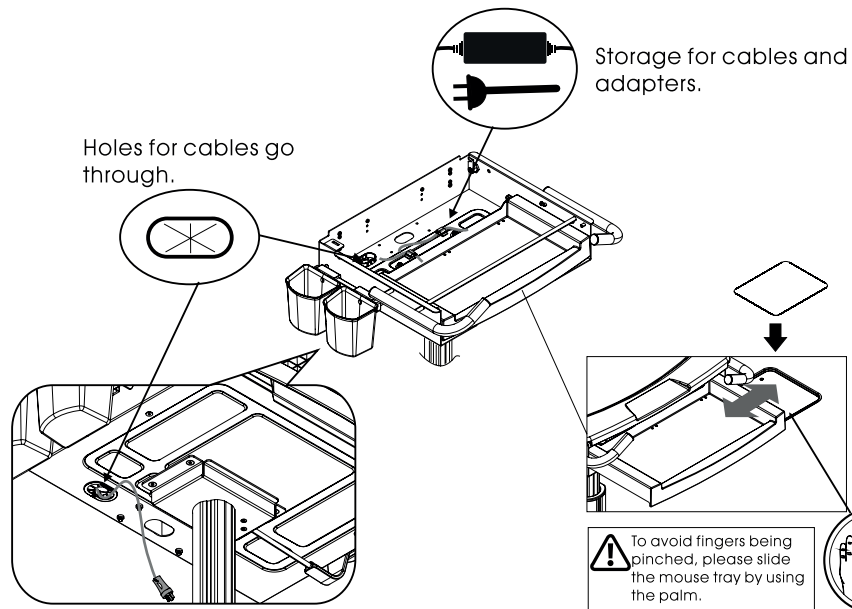

Release Brake to move riser.

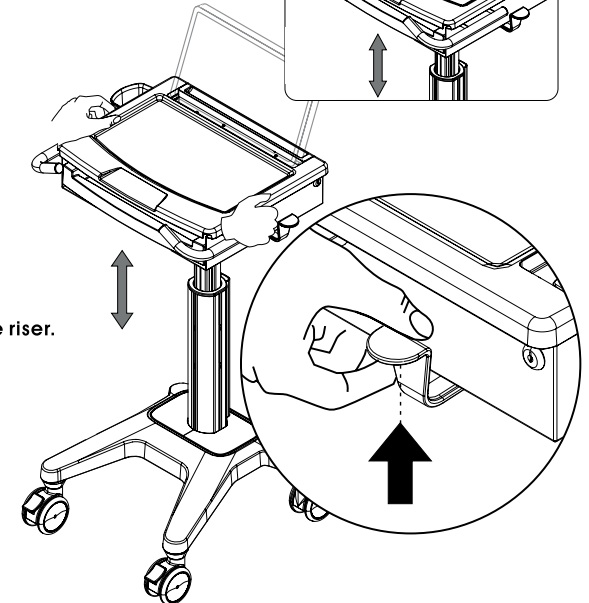

Summary of warnings

⚠ WARNING Please notice that latch must be pushed forward after replacing the work surface.

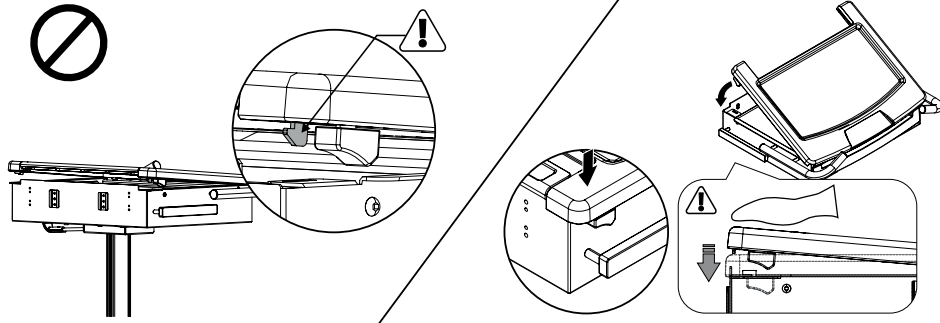

⚠ WARNING

When the cart needs to go across bumpy road or barriers, please lift up the cart from bottom of keyboard compartment as figure. Do not lift up from handles.

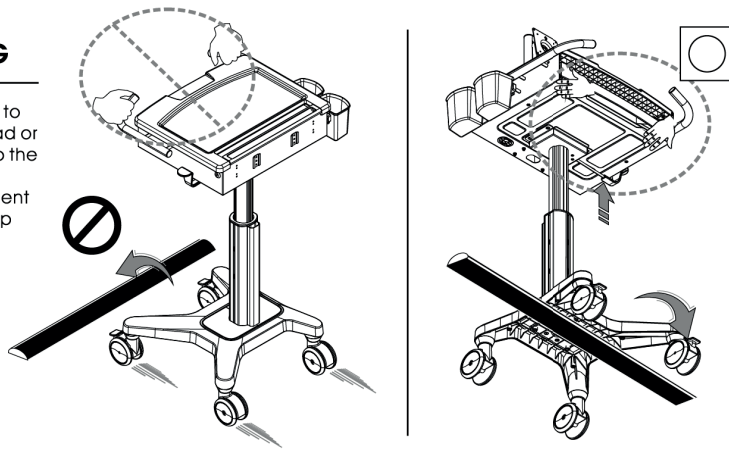

⚠ WARNING When the cart is in motionless, please brake the two front casters.

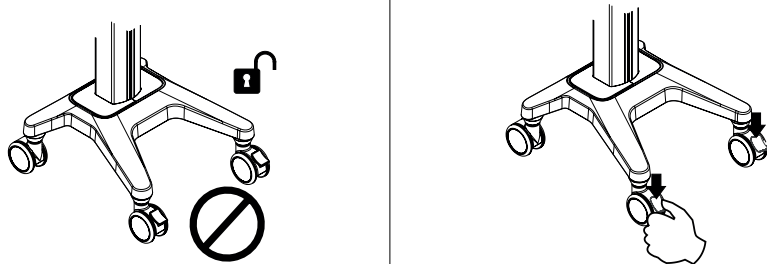

⚠ WARNING

Notice:
While releasing brake to move the height of work surface riser or lower, please put two hands on two sides of work surface as figure. Do not push the center of work surface for lower adjustment. Please use two hands to uphold slightly for riser adjustment if the work surface is still motionless.

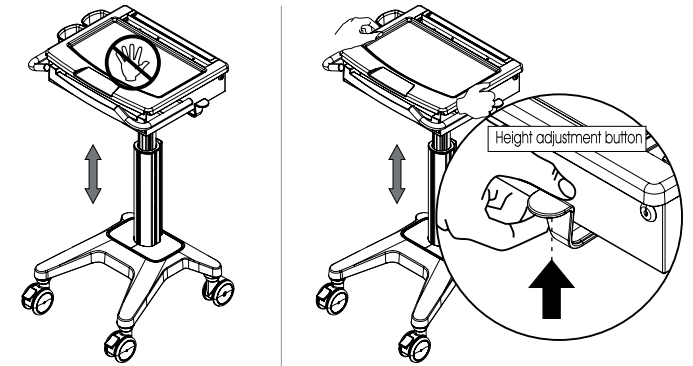

⚠ WARNING

Please do not press the whole work surface especially the center area except height adjustment.



Notes

Maintenance

All cart maintenance must be carried out at least once a month by a professional technician.

Cleaning Warning

▲ Because the cart is under the environment of electrical equipment, inflammable cleansers are forbidden using strictly.

- (1) Before cleaning the cart, please confirm the cart is unplugged from the mains and switched off.
- (2) Please confirm the cart is entirely in dry status before plugging the power into socket.
- (3) While cleaning the cart, please use damp cloth to wipe off the superficial cleansers until completely dry.
- (4) The cart is not only forbidden in moist environment but also forbidden liquids running into the cart.
- (5) To avoid surface finish being damaged, do not use any abrasive materials for clean.
- (6) Before using any cleanser on the cart, please test it on a small part to see whether the surface is damaged or not.

Please be cautioned that these guidelines can not ensure infection control. Please kindly consult hospital's infection control consultant for cleaning advice.

Cleaning Recommendations

- (1) Please use non-abrasive or diluted products to clean plastic components such as soap、water and diluted alcohol.
 - (2) If there are spots of pen or marker on the cart's surface, a soft cloth with 91% isopropyl alcohol is suggested for clean.
 - (3) If there are iodine spots on the cart's surface, a soft cloth with above cleansers is suggested for clean.
- ▲ The following chemicals are forbidden strictly cleaning the cart :
Abrasive cleansers、Acetone、Mineral spirits、Paint thinner or any other harsh or toxic chemicals.

Inspections

All cart inspections must be carried out at least once a month by a professional technician.



In case of faults or damage occurring, stop operating this cart and contact distributors for further assistance instantly.

Caster

To allow cart move as intended, please inspect the casters regularly and keep the cart away from destroyed and untidy ground.

The maximum weight of the cart is 40 kg.

Loading Capacity

Weight capacity	 1 ~ 5 kg
Laptop/monitor	 ~ 5 kg

Fasteners

If there are any fasteners turning into loose and need to be tightened, do not screw fasteners over tightly. Over tighten fasteners/screws might cause not only screws but also components damage.

Troubleshooting

Cart is difficult to move

Ensure the two front locking casters are not locked.
Inspect whether there are any debris sticking to casters.

Cart is difficult to adjust height

1. When the lift mechanism is unable for lift and descent, ensure the lift brake is pressed completely.
2. And then lift the work surface up slightly to prevent work surface rising rapidly.
3. If lift mechanism still doesn't work, please contact distributors for further assistance.
4. If the lift mechanism keeps going up automatically, please contact distributors for further assistance.