



Hardware Reference Guide

HP EliteOne 1000 G2 All-in-One Business PCs

© Copyright 2018 HP Development Company, L.P.

Thunderbolt and the Thunderbolt logo are trademarks of Intel Corporation or its subsidiaries in the U.S. and/or other countries. Windows is either a trademark or registered trademark of Microsoft Corporation in the United States and/or other countries.

The information contained herein is subject to change without notice. The only warranties for HP products and services are set forth in the express warranty statements accompanying such products and services. Nothing herein should be construed as constituting an additional warranty. HP shall not be liable for technical or editorial errors or omissions contained herein.

First Edition: June 2018

Document part number: L28134-001

Product notice

This guide describes features that are common to most models. Some features may not be available on your computer.

Software terms

By installing, copying, downloading, or otherwise using any software product preinstalled on this computer, you agree to be bound by the terms of the HP End User License Agreement (EULA). If you do not accept these license terms, your sole remedy is to return the entire unused product (hardware and software) within 14 days for a full refund subject to the refund policy of your seller.

For any further information or to request a full refund of the computer, please contact your local point of sale (the seller).

About This Book

This guide provides basic information for upgrading this computer model.





-
-  **WARNING!** Indicates a hazardous situation that, if not avoided, **could** result in death or serious injury.
 -  **CAUTION:** Indicates a hazardous situation that, if not avoided, **could** result in minor or moderate injury.
 -  **IMPORTANT:** Indicates information considered important but not hazard-related (for example, messages related to property damage). A notice alerts the user that failure to follow a procedure exactly as described could result in loss of data or in damage to hardware or software. Also contains essential information to explain a concept or to complete a task.
 -  **NOTE:** Contains additional information to emphasize or supplement important points of the main text.
 -  **TIP:** Provides helpful hints for completing a task.
-



Table of contents

1 Product features	1
Overview	1
Base unit top components	1
Base unit side components	2
Base unit rear components	2
Monitor front components (select products only)	3
Webcam components	3
Infrared (IR) webcam (optional)	3
Full High Definition (FHD) webcam (optional)	4
Serial and product number locations	4
2 Setup	5
Installing the monitor head	5
Connecting the power supply	8
Enabling the monitor head detection warning	9
Installing a security cable	9
Adjusting the monitor head position	10
Connecting a secondary monitor	11
Using the webcam	12
Webcam operation	12
Setting up Windows Hello	12
Synchronizing the optional wireless keyboard and mouse	13
3 Hardware repair and upgrade	14
Warnings and cautions	14
Additional information	14
Removing and replacing the base unit access covers	15
Removing and replacing the monitor head	17
Locating internal components	21
Removing and installing memory	21
Memory module specifications	21
Populating memory modules	22
Installing memory modules	22
Replacing the RTC battery	23
Replacing the hard drive	25
Removing or installing an M.2 SSD	26

Replacing or installing a webcam	28
Appendix A Electrostatic discharge	31
Preventing electrostatic damage	31
Grounding methods	31
Appendix B Computer operating guidelines, routine care, and shipping preparation	32
Computer operating guidelines and routine care	32
Shipping preparation	33
Appendix C Accessibility	34
Supported assistive technologies	34
Contacting support	34
Index	35

1 Product features

Overview



 **NOTE:** For the latest manuals on this product, go to <http://www.hp.com/support>. Select **Find your product**, and then follow the on-screen instructions.

Base unit top components

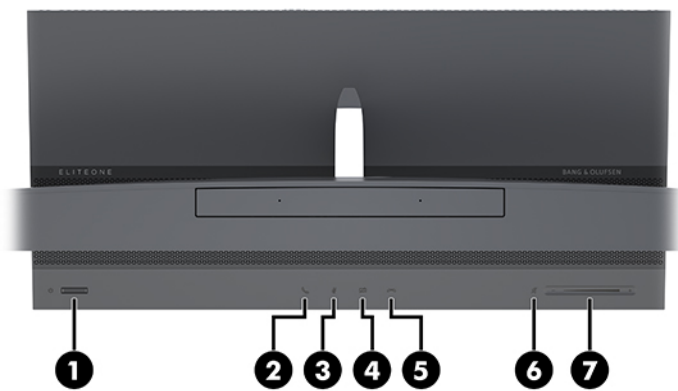

Components

(1) Power button	(5) End call button
(2) Call button	(6) Speaker mute button
(3) Microphone mute button	(7) Volume slider
(4) Webcam mute button	

Base unit side components

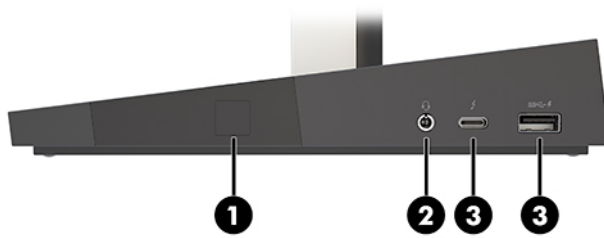

Components

(1) Fingerprint reader	(3) USB Type-C Thunderbolt™ port with HP Sleep and Charge
(2) Audio-out (headphone)/Audio-in (microphone) combo jack	(4) USB SuperSpeed port with HP Sleep and Charge

Base unit rear components

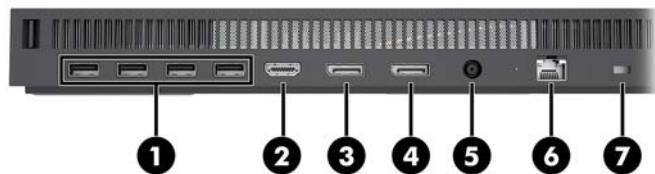

Components

(1) USB SuperSpeed Plus ports (4)	(5) Power connector
(2) HDMI port	(6) RJ-45 (network) jack
(3) DisplayPort Out	(7) Security cable slot
(4) DisplayPort In	

Monitor front components (select products only)

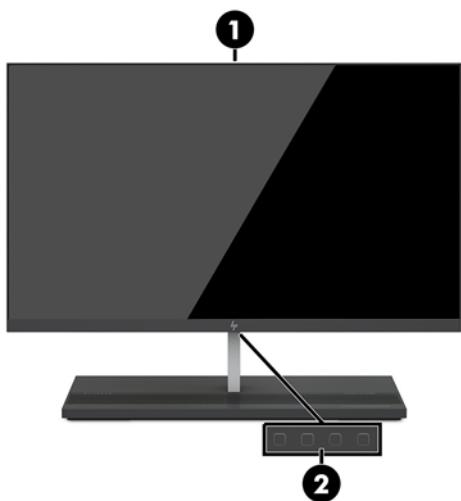

Components	
(1)	Webcam
(2)	On-screen display buttons (for adjusting the screen)

Webcam components

Infrared (IR) webcam (optional)

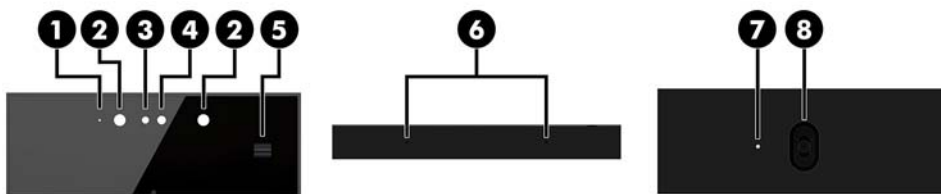

Components	
Front View	
(1)	Webcam light
(2)	IR light
(3)	Full High Definition (FHD) webcam
(4)	IR webcam
(5)	Rear webcam adjustment wheel
Top view	
(6)	Digital microphones
Rear view	
(7)	Webcam light
(8)	FHD webcam

Full High Definition (FHD) webcam (optional)



Components

Front view

- (1) Webcam light
- (2) FHD webcam

Top view

- (3) Digital microphones
-

Serial and product number locations

Each computer has a unique serial number and product ID number that are located on the exterior of the device. Keep these numbers available for use when contacting customer service for assistance.

The computer base unit numbers are located on the underside of the base unit.



2 Setup

Installing the monitor head

A monitor head can be installed in the standalone computer base. The monitor head can then be removed and replaced with a different monitor.

1. Remove all removable media, such as USB flash drives, from the computer.
2. Turn off the computer properly through the operating system, and turn off any external devices.
3. Disconnect the power cord from the AC outlet and disconnect any external devices.

 **IMPORTANT:** Regardless of the power-on state, voltage is always present on the system board as long as the system is plugged into an active AC outlet. You must disconnect the power cord and wait approximately 30 seconds for the power to drain to avoid damage to the internal components of the computer.

4. To remove the rear access cover to access the monitor head installed in a different computer, press the two release buttons on the rear of the base unit (1), and at the same time rotate the rear of the cover up (2). Then, slide the cover back to remove it from the base (3).

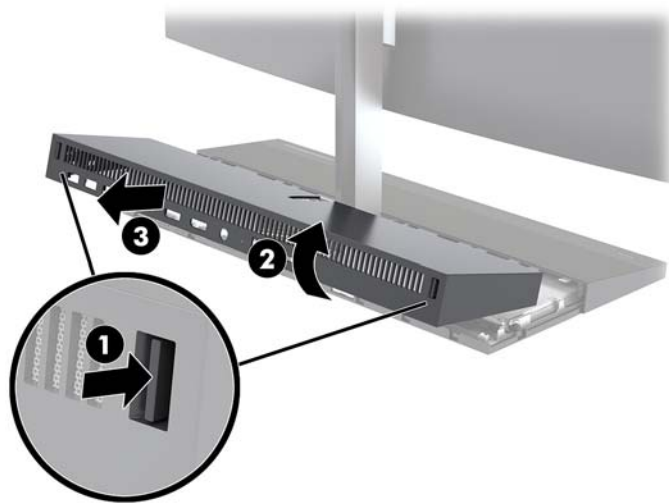

5. Disconnect the two monitor cables attached to the system board by squeezing firmly inward on the two ends of the cable connectors (1) and pulling the cable connectors up and off the system board (2).

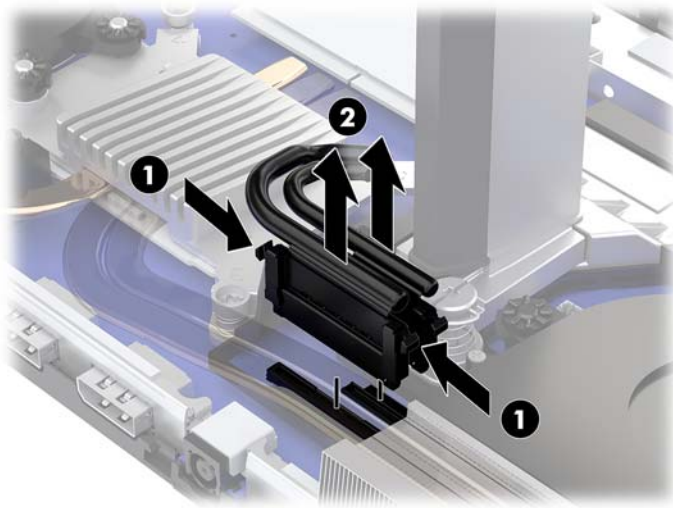

6. To remove the rear access cover from the computer, press the two release buttons on the rear of the base unit (1), and at the same time rotate the rear of the cover up (2). Then, slide the cover back to remove it from the computer (3).

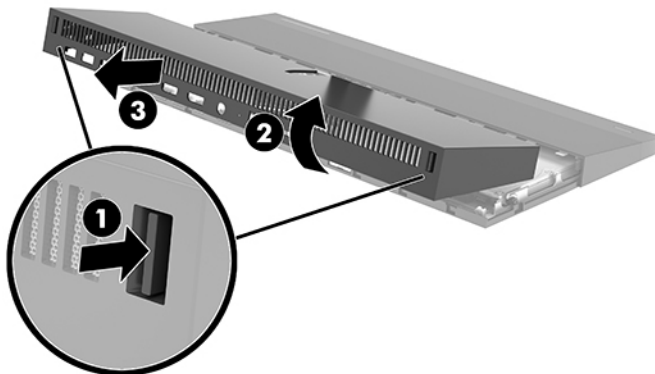

7. Turn the cover over. Lift the tab on the blank, and then slide the blank away from the rear cover to remove it.

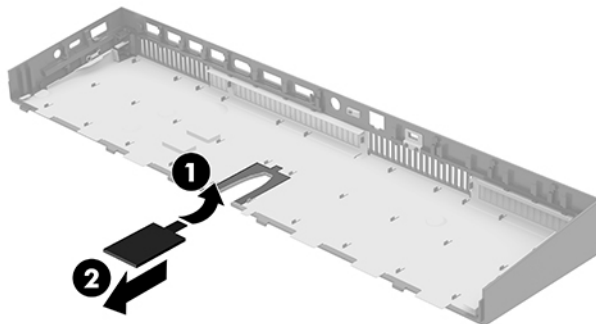

8. Loosen the two captive screws at the base of the monitor head's neck (1). While holding onto the bottom of the monitor head from the front with one hand, slide the monitor head back with your other hand to clear it from the small metal retention tab, and then lift the monitor off the base (2).

 **IMPORTANT:** The monitor head is heavy. Make sure you are holding the monitor head firmly when removing it to prevent the monitor head from falling over and being damaged.



9. To replace the monitor head, hold the bottom of the monitor head from the front with one hand and place the base of the monitor head's neck onto the bracket on the base unit and slide the monitor forward (1) with the other hand. Then tighten the two captive screws that secure the monitor head's neck to the base unit (2).

 **IMPORTANT:** The monitor head is heavy. Make sure you are holding the monitor head firmly when replacing it to prevent the monitor head from falling over and being damaged.



10. Connect the two monitor cables to the system board connectors.

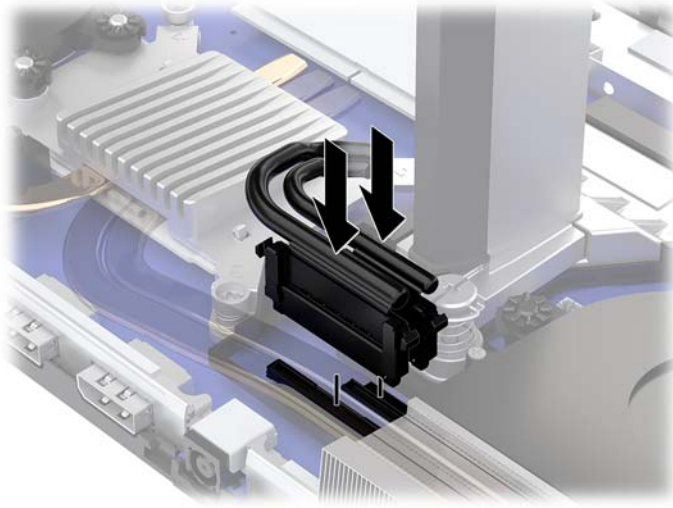

11. To replace the rear access cover, slide the tabs on the front of the rear cover into the slots on the rear of the front cover (1), and then press the rear of the rear cover down (2).



NOTE: Be sure that all cables are properly routed to prevent damage when the cover is replaced.

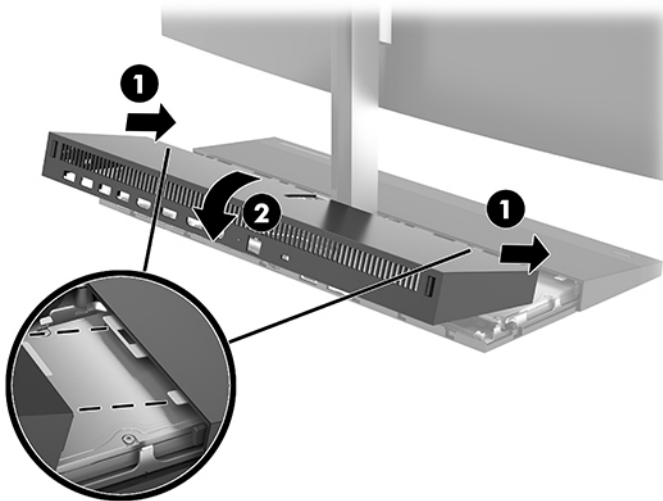

12. Reconnect the power cord and any external devices, and then turn on the computer.

Connecting the power supply

To connect the power supply, connect one end of the power cord to the AC adapter (1) and the other end to a grounded AC outlet (2), and then connect the AC adapter to the DC power connector on the computer base unit (3).

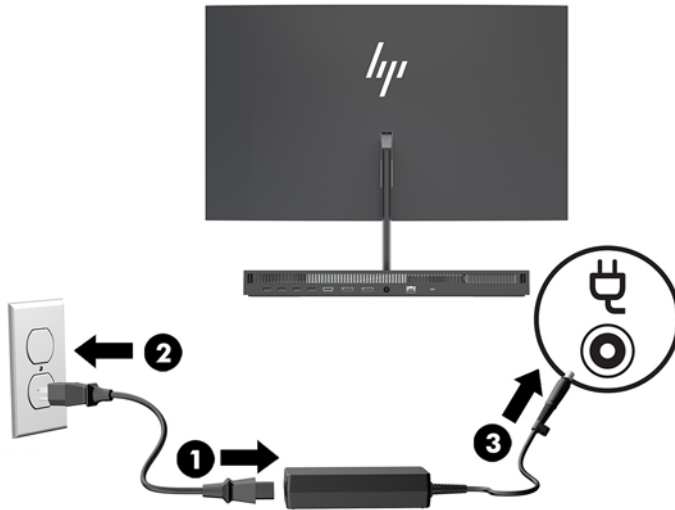

Enabling the monitor head detection warning

This warning is monitored if the monitor head cables are not fully connected. HP recommends ensuring that this warning is enabled on systems with an installed monitor head.

1. Turn on or restart the computer, and when the HP logo appears, press **f10** to enter Computer Setup.
2. Select **Advanced**, and then select **Built-In Devices**.
3. Select **Allow No Panel configuration**.
4. Select **Main**, and then **Save Changes and Exit** to save your settings.

Your changes take effect when the computer restarts.

Installing a security cable

A security cable is a key lock device that has a wire cable attached. Attach one end of the cable to your desk (or other stationary object) and the other end of the cable to the security cable slot on the computer base unit. Secure the security cable lock with the key.

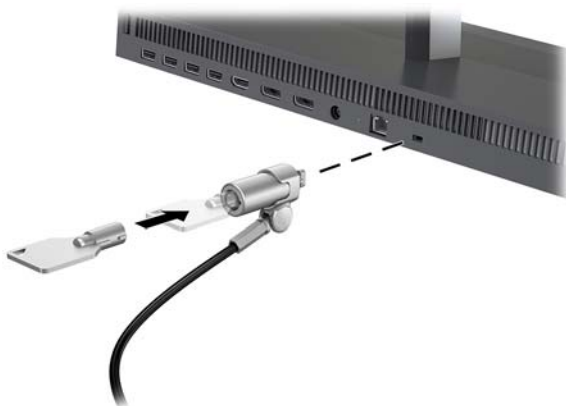

Adjusting the monitor head position

Tilt the monitor head to set it to a comfortable eye level.

 **NOTE:** The 23.8-inch, 27-inch, and 34-inch monitor heads tilt back. Only the 23.8-inch and 27-inch monitor heads tilt forward. The 34-inch monitor head does not tilt forward.



Adjust the height of the monitor head to set it to a comfortable eye level.

 **NOTE:** Only the 23.8-inch monitor head has height adjustment. The 27-inch and 34-inch monitor heads do not have height adjustment.

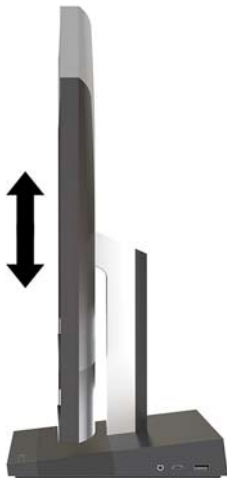

Connecting a secondary monitor

The DisplayPort and HDMI ports on the rear of the computer allow you to connect secondary monitors to the computer.

You can connect up to two monitors in one of the following configurations:

- Two monitors daisy-chained to the DisplayPort
- One monitor connected to the DisplayPort and one to the HDMI port

If you are adding a monitor that has a DisplayPort or an HDMI port, then no video adapter is required. If you are adding a monitor that does not have a DisplayPort or HDMI port, you can purchase a video adaptor from HP for your configuration.

DisplayPort adapters, HDMI adapters, and video cables are purchased separately. HP offers the following adapters:

- DisplayPort to VGA adapter
- DisplayPort to DVI adapter
- HDMI to VGA adapter
- HDMI to DVI adapter

To connect a monitor:

1. Turn off power to the computer and the monitor that you are connecting to the computer.
2. If your monitor has a DisplayPort port, connect a DisplayPort cable directly between the DisplayPort port on the rear of the computer and the DisplayPort port on the monitor.

If your monitor has an HDMI port, connect an HDMI cable directly between the HDMI port on the rear of the computer and the HDMI port on the monitor.
3. If your monitor does not have a DisplayPort port, connect a DisplayPort video adapter to the DisplayPort port on the computer. Then connect a cable (VGA or DVI, depending on your application) between the adapter and a monitor.

If your monitor does not have an HDMI port, connect an HDMI video adapter to the HDMI port of the computer. Then connect a cable (VGA or DVI, depending on your application) between the adapter and a monitor.
4. Turn on power to the computer and the monitor.

 **NOTE:** Use the graphics card software or the Windows Display Settings to configure the display as a mirrored image of the computer display or an extension of the computer display.

Using the webcam

You can use the webcam on the monitor in the following ways:

- Stream online video conferences
- Send and receive Instant messages
- Schedule meetings
- Maintain security over conversations

Webcam operation

- To raise the webcam, press it down to unlock it.
- To close the webcam, press it down until it locks.

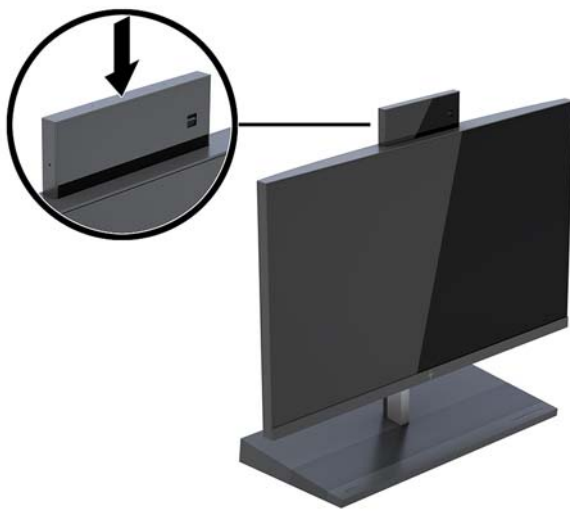

Setting up Windows Hello

If the Windows® 10 operating system is installed on your computer, follow these steps to set up Windows Hello facial recognition:

1. Select the **Start** button, select **Settings**, select **Accounts**, and then select **Sign-in options**.
2. Under **Windows Hello**, follow the on-screen instructions to add both a password and a 4-digit PIN. Then enroll your fingerprint or facial ID.

Synchronizing the optional wireless keyboard and mouse

The wireless keyboard and mouse are optional components. The mouse and keyboard are synchronized at the factory. If the mouse and keyboard are not synchronized, then follow the procedure below to manually re-synchronize the pair.

1. Insert the transceiver into a USB port on the computer.

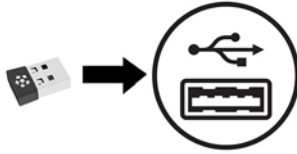

2. Place the keyboard within 30 cm of the transceiver. Press the connect button on the bottom of the keyboard, and then press a key on the keyboard.

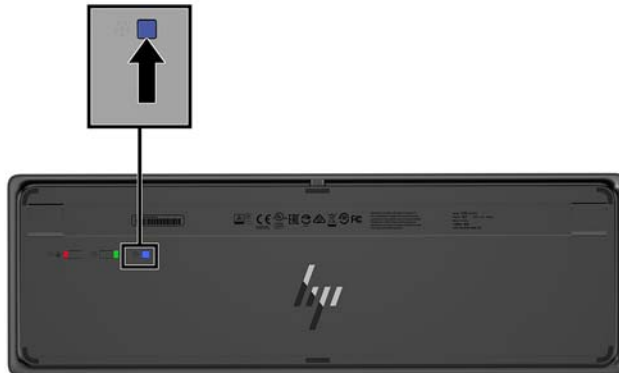

3. Place the mouse within 30 cm of the transceiver. Press the connect button on the bottom of the mouse, and then click the mouse.



 **NOTE:** If the mouse and keyboard still do not work, synchronize the keyboard and mouse again.

3 Hardware repair and upgrade

Warnings and cautions

Before performing upgrades be sure to carefully read all of the applicable instructions, cautions, and warnings in this guide.

 **WARNING!** To reduce the risk of personal injury from electrical shock, hot surfaces, or fire:

Disconnect the power cord from the AC outlet before removing the enclosure. Energized parts are inside.

Allow the internal system components to cool before you touch them.

Replace and secure the enclosure before restoring power to the equipment.

Do not connect telecommunications or telephone connectors to the network interface controller (NIC) receptacles.

Do not disable the power cord grounding plug. The grounding plug is an important safety feature.

Plug the power cord in a grounded (earthed) AC outlet that is easily accessible at all times.

For your safety, do not place anything on power cords or cables. Arrange them so that no one may accidentally step on or trip over them. Do not pull on a cord or cable. When unplugging from the AC outlet, grasp the cord by the plug.

To reduce the risk of serious injury, read the *Safety & Comfort Guide*. It describes proper workstation setup and provides guidelines for posture and work habits that increase your comfort and decrease your risk of injury. It also provides electrical and mechanical safety information. This guide is located on the web at <http://www.hp.com/ergo>.

 **IMPORTANT:** Static electricity can damage the electrical components of the computer or optional equipment. Before beginning these procedures, ensure that you are discharged of static electricity by briefly touching a grounded metal object. See [Electrostatic discharge on page 31](#) for more information.

When the computer is plugged into an AC power source, voltage is always applied to the system board. You must disconnect the power cord from the power source before opening the computer to prevent damage to internal components.

Additional information

For more information on removing and replacing hardware components, the Computer Setup utility, and troubleshooting, refer to the *Maintenance and Service Guide* (available in English only) for your computer model at <http://www.hp.com/support>.

Removing and replacing the base unit access covers

The base unit access covers must be removed to access internal computer components.

1. Remove all removable media, such as USB flash drives, from the computer.
2. Turn off the computer properly through the operating system, and turn off any external devices.
3. Disconnect the power cord from the AC outlet and disconnect any external devices.

 **IMPORTANT:** Regardless of the power-on state, voltage is always present on the system board as long as the system is plugged into an active AC outlet. You must disconnect the power cord and wait approximately 30 seconds for the power to drain to avoid damage to the internal components of the computer.

4. To remove the rear access cover, press the two release buttons on the rear of the base unit (1), and at the same time rotate the rear of the cover up (2). Then slide the cover back to remove it from the base (3).

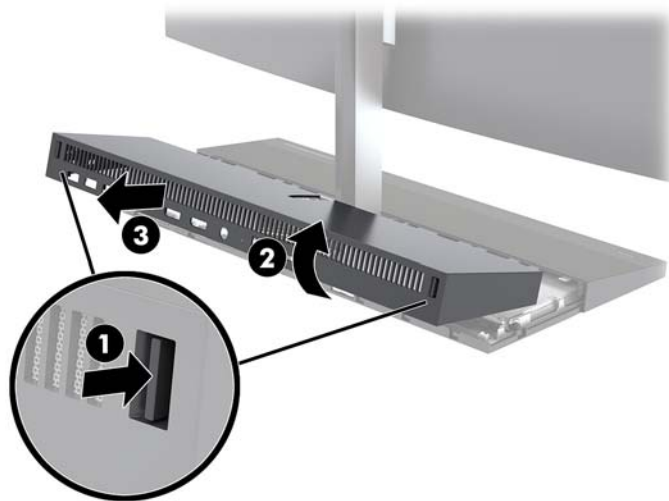

5. To remove the front access cover after removing the rear access cover:
 - a. Press the two release buttons on the rear of the front cover (1) and lift the cover straight up (2) to remove it.

 **NOTE:** There is a cable connected to the right side of the front cover. Be careful not to pull the cover up too far and cause the cable to disconnect.

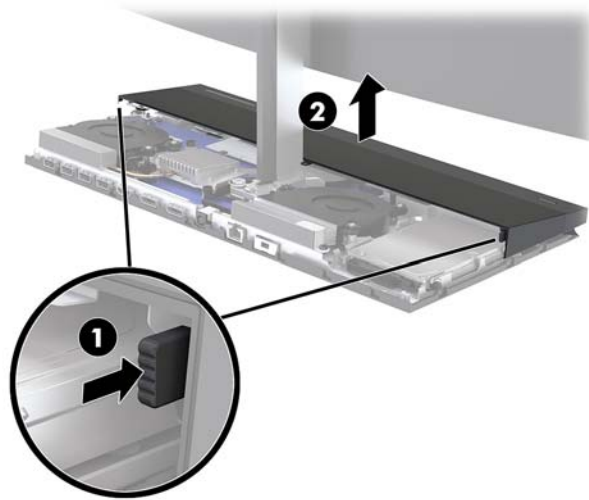

- b.** Rotate the left side of the cover away from the base unit while being careful not to disconnect the cable attached to the right side of the cover.

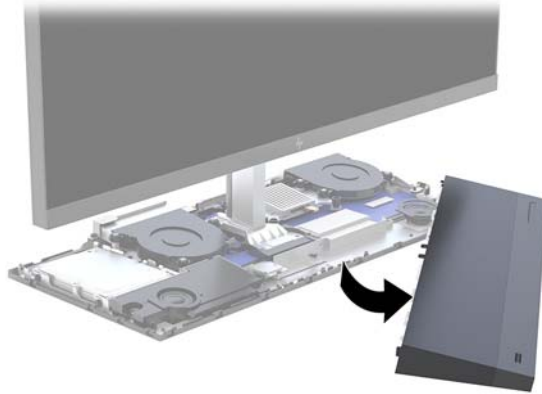

You can now service the computer components.

To replace the access covers:

- 1.** To replace the front access cover, align the cover with the monitor head and then press the cover straight down onto the base unit so that the cover snaps in place.

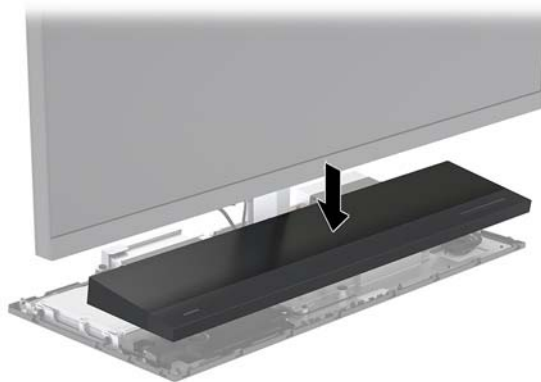

2. To replace the rear access cover, slide tabs on the front of the rear cover into the slots on the rear of the front cover (1), and then press the rear of the rear cover down (2).

 **NOTE:** Be sure that all cables are properly routed to prevent damage when the cover is replaced.

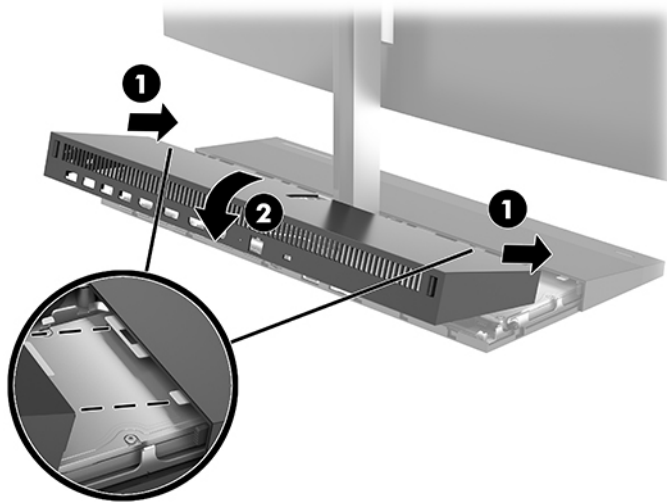

3. Reconnect the power cord and any external devices, and then turn on the computer.

Removing and replacing the monitor head

The monitor head can be removed and replaced with a different monitor.

 **NOTE:** Replacement monitors do not include a webcam. If your current monitor has a webcam, be sure to remove and save it. See [Replacing or installing a webcam on page 28](#).

1. Remove all removable media, such as USB flash drives, from the computer.
2. Turn off the computer properly through the operating system, and turn off any external devices.
3. Disconnect the power cord from the AC outlet and disconnect any external devices.

 **IMPORTANT:** Regardless of the power-on state, voltage is always present on the system board as long as the system is plugged into an active AC outlet. You must disconnect the power cord and wait approximately 30 seconds for the power to drain to avoid damage to the internal components of the computer.

4. To remove the rear access cover, press the two release buttons on the rear of the base unit (1), and at the same time rotate the rear of the cover up (2). Then slide the cover back to remove it from the base (3).

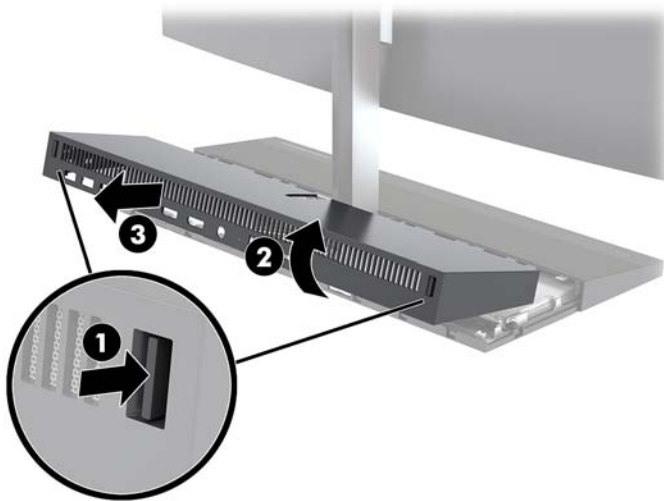

5. Disconnect the two monitor cables attached to the system board by firmly squeezing inward on the two ends of the cable connectors (1) and pulling the cable connectors up and off the system board (2).

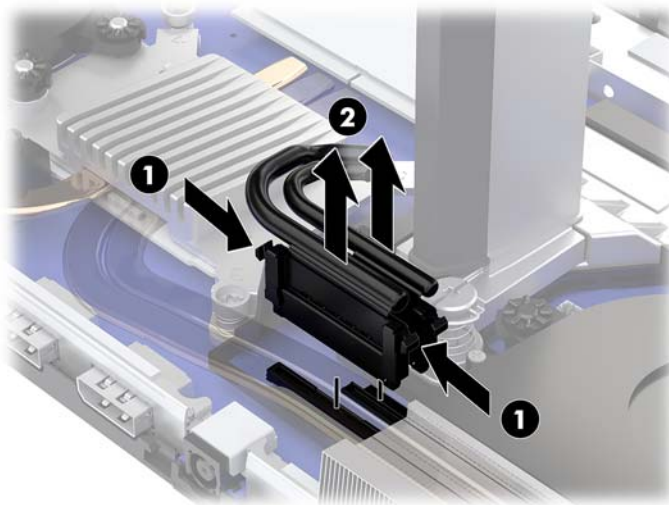

6. Loosen the two captive screws at the base of the monitor head's neck (1). While holding onto the bottom of the monitor head from the front with one hand, slide the monitor head back with your other hand to clear it from the small metal retention tab, and then lift the monitor off the base (2).

 **IMPORTANT:** The monitor head is heavy. Make sure you are holding the monitor head firmly when removing it to prevent the monitor head from falling over and being damaged.



7. To replace the monitor head, hold the bottom of the monitor head from the front with one hand and place the base of the monitor head's neck onto the bracket on the base unit and slide the monitor forward (1) with the other hand. Then tighten the two captive screws that secure the monitor head's neck to the base unit (2).

 **IMPORTANT:** The monitor head is heavy. Make sure you are holding the monitor head firmly when replacing it to prevent the monitor head from falling over and being damaged.



8. Connect the two monitor cables to the system board connectors.

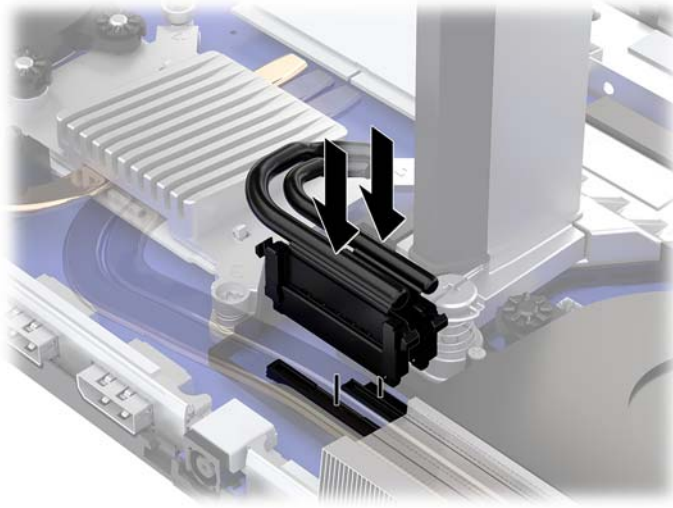

9. To replace the rear access cover, slide tabs on the front of the rear cover into the slots on the rear of the front cover (1), and then press the rear of the rear cover down (2).

 **NOTE:** Be sure that all cables are properly routed to prevent damage when the cover is replaced.

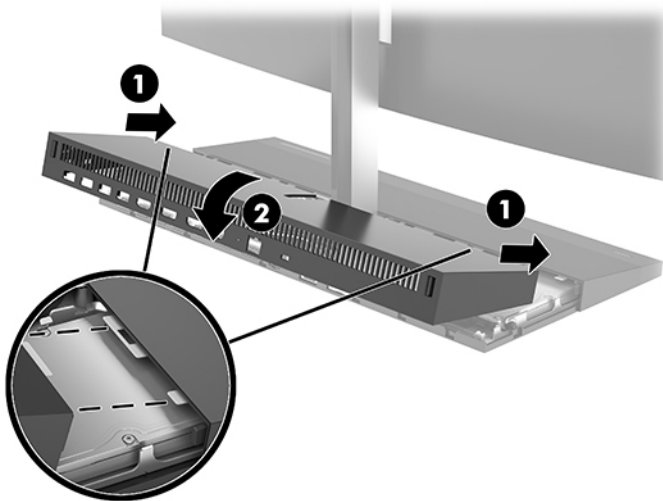

10. Reconnect the power cord and any external devices, and then turn on the computer.

Locating internal components

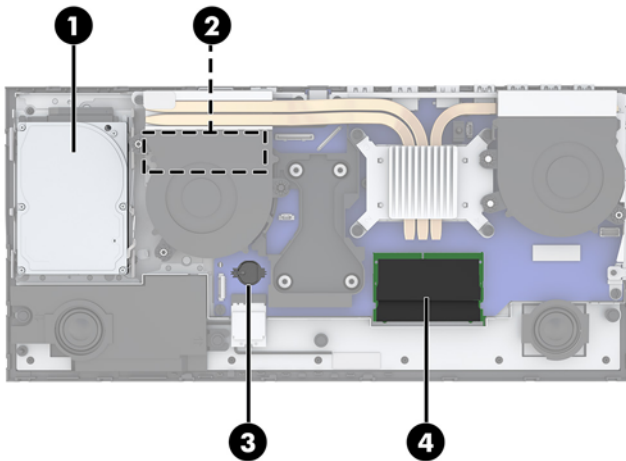

Components

(1) Hard drive	(3) RTC battery
(2) M.2 SSD (under the fan)	(4) Memory modules

Removing and installing memory

The memory slots on the system board can be populated with up to two industry-standard small outline dual inline memory modules (SODIMMs). These memory slots are populated with at least one preinstalled memory module.

Memory module specifications

For proper system operation, the memory modules must meet the following qualifications:

Component	Specification
Memory modules	1.2 volt DDR4-SDRAM memory modules
Compliance	Unbuffered non-ECC DDR4-2400 MHz-compliant
Pins	Industry-standard 260 pins containing the mandatory Joint Electronic Device Engineering Council (JEDEC) specification
Support	Support CAS latency DDR4 2400 MHz (15-15-15 timing)
Slots	2
Maximum Memory	16 GB per memory slot, 32 GB total
Supported	4 Gbit and 8 Gbit non-ECC memory technologies single-sided and double-sided SODIMMs
Note	The system will not operate properly if you install unsupported SODIMM memory. SODIMMs constructed with x8 and x16 DDR devices are supported; memory modules constructed with x4 SDRAM are not supported.

HP offers upgrade memory for this computer and advises that the consumer purchase it to avoid compatibility issues with unsupported third-party memory.

Populating memory modules

Refer to the following table to identify the memory module channel locations.

Location	System board label	Channel
Lower Socket	SODIMM1	Channel B
Upper Socket	SODIMM3	Channel A

The system will automatically operate in single channel mode, dual channel mode, or flex mode, depending on how the memory modules are installed.

- The system will operate in single channel mode if the memory module slots are populated in one channel only.
- The system will operate in a higher-performing dual channel mode if the memory capacity of the memory module in Channel A is equal to the memory capacity of the memory module in Channel B.
- The system will operate in flex mode if the memory capacity of the memory module in Channel A is not equal to the memory capacity of the memory module in Channel B. In flex mode, the channel populated with the least amount of memory describes the total amount of memory assigned to dual channel and the remainder is assigned to single channel. If one channel will have more memory than the other, the larger amount should be assigned to channel A.
- In any mode, the maximum operational speed is determined by the slowest memory module in the system.

Installing memory modules

There are two memory sockets on the system board. To remove or install memory modules:

1. Remove all removable media, such as USB flash drives, from the computer.
2. Turn off the computer properly through the operating system, and turn off any external devices.
3. Disconnect the power cord from the AC outlet and disconnect any external devices.



IMPORTANT: You must disconnect the power cord and wait approximately 30 seconds for the power to drain before adding or removing memory modules. Regardless of the power-on state, voltage is always supplied to the memory modules as long as the computer is plugged into an active AC outlet. Adding or removing memory modules while voltage is present may cause irreparable damage to the memory modules or system board.

4. Remove the base unit rear and front access panels. See [Removing and replacing the base unit access covers on page 15](#).
5. To locate the memory modules on the system board, see [Locating internal components on page 21](#).

6. To remove a memory module, press outward on the two latches on each side of the memory module (1), and then pull the memory module out of the socket (2).



7. To install a memory module, slide the memory module into the socket at approximately a 30° angle (1), and then press the memory module down (2) so that the latches lock it in place.



NOTE: A memory module can be installed in only one way. Match the notch on the module with the tab on the memory slot.

8. Replace the base unit front and rear access panels. See [Removing and replacing the base unit access covers on page 15](#).
9. Reconnect the power cord and any external devices, and then turn on the computer. The computer automatically recognizes the additional memory when you turn on the computer.

Replacing the RTC battery

The RTC battery that comes with the computer provides power to the real-time clock. When replacing the battery, use a battery equivalent to the battery originally installed in the computer. The computer comes with a 3-volt lithium coin cell battery.

WARNING! The computer contains an internal lithium manganese dioxide battery. There is a risk of fire and burns if the battery is not handled properly. To reduce the risk of personal injury:

Do not attempt to recharge the battery.

Do not expose to temperatures higher than 60°C (140°F).

Do not disassemble, crush, puncture, short external contacts, or dispose of in fire or water.

Replace the battery only with the HP spare designated for this product.

 **IMPORTANT:** Before replacing the battery, it is important to back up the computer CMOS settings. When the battery is removed or replaced, the CMOS settings will be cleared.

Static electricity can damage the electronic components of the computer or optional equipment. Before beginning these procedures, ensure that you are discharged of static electricity by briefly touching a grounded metal object.

 **NOTE:** The lifetime of the lithium battery can be extended by plugging the computer into a live AC outlet. The lithium battery is only used when the computer is NOT connected to AC power.

HP encourages customers to recycle used electronic hardware, HP original print cartridges, and rechargeable batteries. For more information about recycling programs, go to <http://www.hp.com/recycle>.

To locate the battery on the system board, see [Locating internal components on page 21](#).

1. Remove all removable media, such as USB flash drives, from the computer.
2. Turn off the computer properly through the operating system, and turn off any external devices.
3. Disconnect the power cord from the AC outlet and disconnect any external devices.

 **IMPORTANT:** Regardless of the power-on state, voltage is always present on the system board as long as the system is plugged into an active AC outlet. You must disconnect the power cord and wait approximately 30 seconds for the power to drain to avoid damage to the internal components of the computer.

4. Remove the base unit rear and front access panels. See [Removing and replacing the base unit access covers on page 15](#).
5. To release the battery from its holder, squeeze the metal clamp that extends above one edge of the battery. When the battery pops up, lift it out (1).
6. To insert the new battery, slide one edge of the replacement battery under the holder's lip with the positive side up. Push the other edge down until the clamp snaps over the other edge of the battery (2).

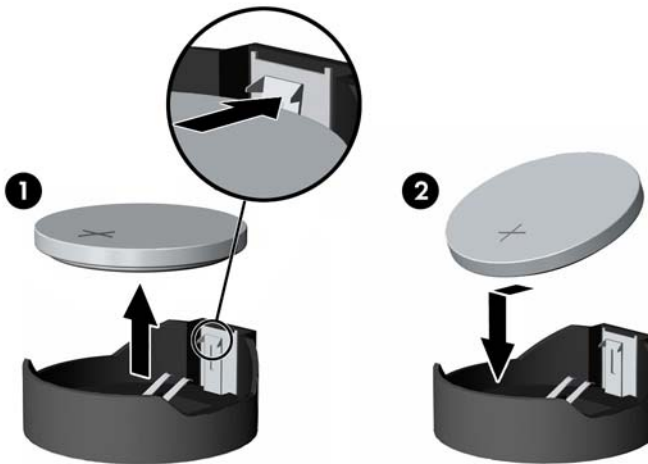

7. Replace the base unit front and rear access panels. See [Removing and replacing the base unit access covers on page 15](#).
8. Reconnect the power cord and any external devices, and then turn on the computer.
9. Reset the date and time, your passwords, and any special system setups using Computer Setup.

Replacing the hard drive

To locate the hard drive on the system board, see [Locating internal components on page 21](#).

1. Remove all removable media, such as USB flash drives, from the computer.
2. Turn off the computer properly through the operating system, and turn off any external devices.
3. Disconnect the power cord from the AC outlet and disconnect any external devices.

 **IMPORTANT:** Regardless of the power-on state, voltage is always present on the system board as long as the system is plugged into an active AC outlet. You must disconnect the power cord and wait approximately 30 seconds for the power to drain to avoid damage to the internal components of the computer.

4. Remove the base unit rear and front access panels. See [Removing and replacing the base unit access covers on page 15](#).
5. Pull the release lever at the front of the drive outward (1). Then slide the drive back until it stops and lift it out of the drive bay (2). And then disconnect the cable from the rear of the hard drive (3).

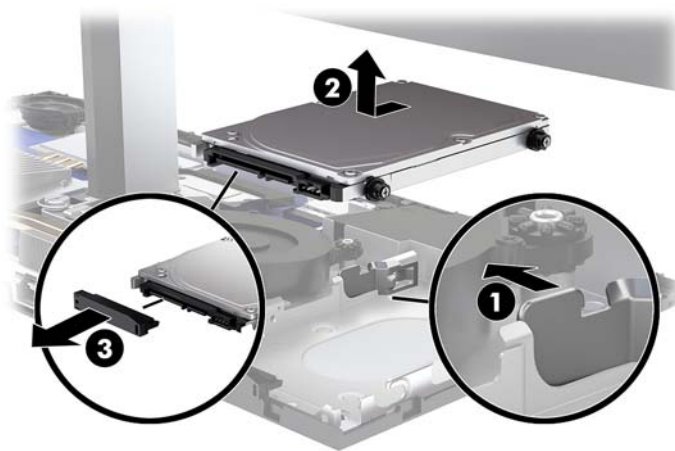

6. Remove the four mounting screws from the sides of the hard drive that was removed.



7. Install the four mounting screws that were removed from the old drive in the sides of the new hard drive.



8. Connect the cable to the rear of the hard drive (1). Then align the mounting screws on the drive with the J-slots on the sides of the drive bay and press the drive into the drive bay. And then slide the drive forward until it locks in place (2).



9. Replace the base unit front and rear access panels. See [Removing and replacing the base unit access covers on page 15](#).
10. Reconnect the power cord and any external devices, and then turn on the computer.

Removing or installing an M.2 SSD

To locate the M.2 SSD on the system board, see [Locating internal components on page 21](#).

1. Remove all removable media, such as USB flash drives, from the computer.
2. Turn off the computer properly through the operating system, and turn off any external devices.
3. Disconnect the power cord from the AC outlet and disconnect any external devices.

 **IMPORTANT:** Regardless of the power-on state, voltage is always present on the system board as long as the system is plugged into an active AC outlet. You must disconnect the power cord and wait approximately 30 seconds for the power to drain to avoid damage to the internal components of the computer.

4. Remove the base unit rear and front access panels. See [Removing and replacing the base unit access covers on page 15](#).
5. The M.2 SSD is located underneath the fan between the monitor head mount and hard drive bay. Pull the fan straight up and off the posts on the system board to remove it. You do not need to disconnect the fan cables.

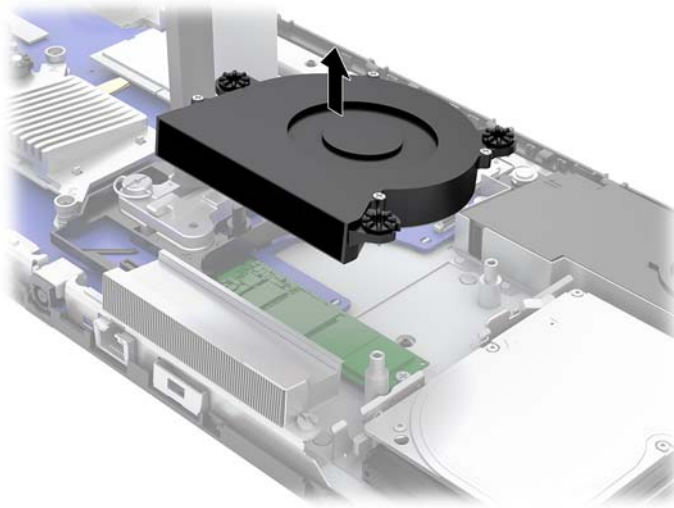

6. To remove an M.2 SSD, remove the screw that secures the SSD to the system board (1), and then slide the SSD out of the system board connector (2).

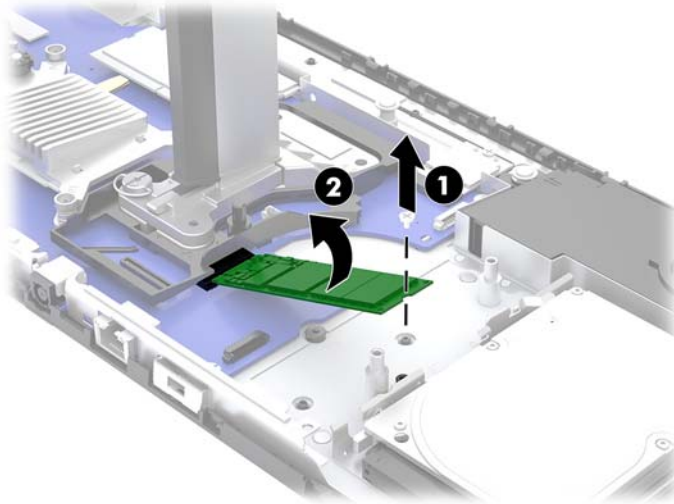

7. To install an M.2 SSD, slide the connector end of the SSD into the system board connector (1), press the other end of the SSD down (2), and then secure the SSD to the system board with the screw (3).

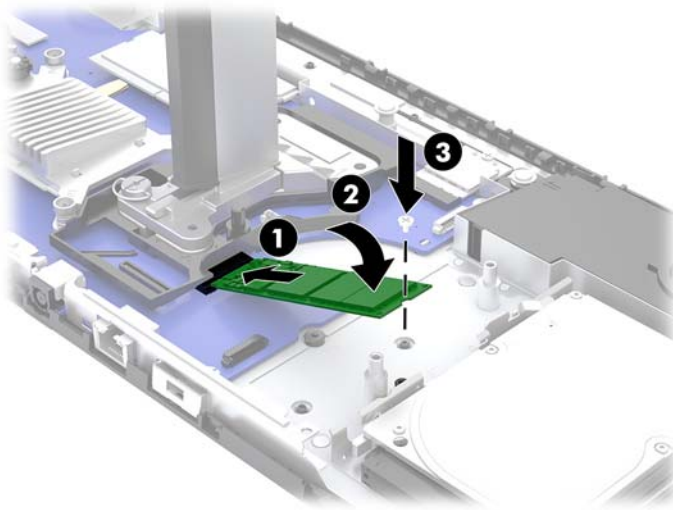

8. Replace the fan by pressing it down onto the system board posts.

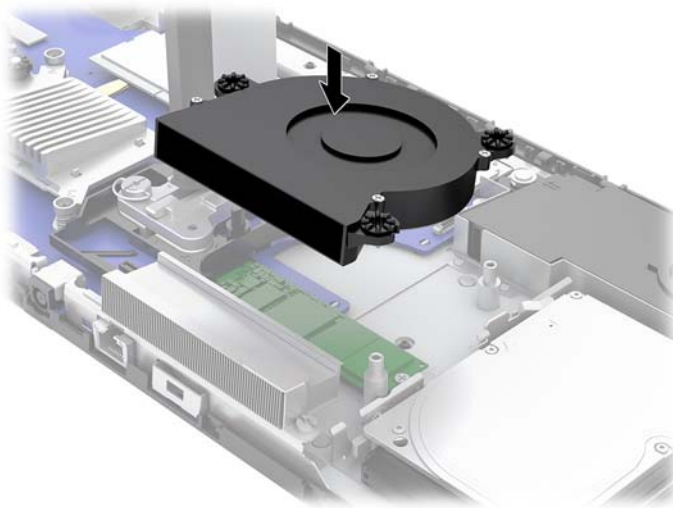

9. Replace the base unit front and rear access panels. See [Removing and replacing the base unit access covers on page 15](#).
10. Reconnect the power cord and any external devices, and then turn on the computer.

Replacing or installing a webcam

To replace a webcam:

1. Remove all removable media, such as USB flash drives, from the computer.
2. Turn off the computer properly through the operating system, and turn off any external devices.
3. Disconnect the power cord from the AC outlet and disconnect any external devices.

 **IMPORTANT:** Regardless of the power-on state, voltage is always present on the system board as long as the system is plugged into an active AC outlet. You must disconnect the power cord and wait approximately 30 seconds for the power to drain to avoid damage to the internal components of the computer.

4. Insert a paper clip into the release holes on each side of the webcam (1) to disengage the internal latches, and then pull the webcam out of the monitor head (2).

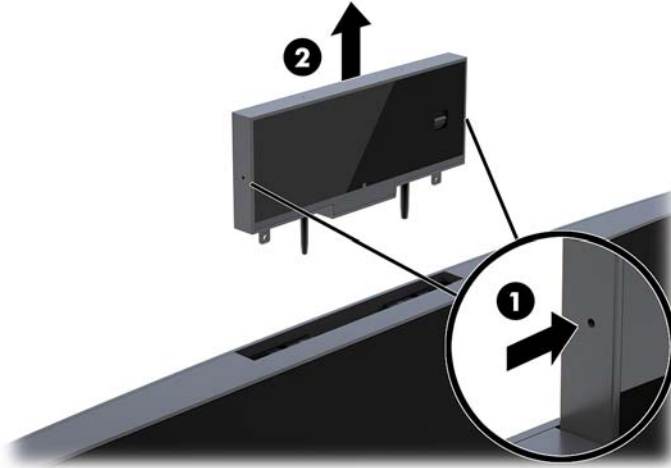

5. Insert the new webcam into the webcam slot on the monitor head and press the webcam down so that it engages the internal latches.

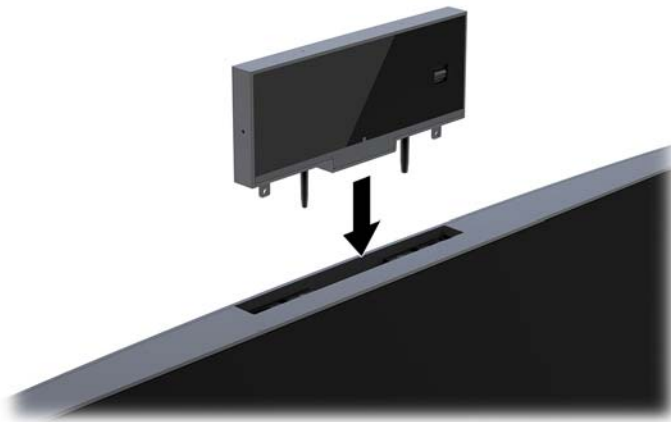

6. Reconnect the power cord and any external devices, and then turn on the computer.

To install a webcam when a webcam blank is installed in the webcam slot on the monitor head:

1. Remove all removable media, such as USB flash drives, from the computer.
2. Turn off the computer properly through the operating system, and turn off any external devices.
3. Disconnect the power cord from the AC outlet and disconnect any external devices.

 **IMPORTANT:** Regardless of the power-on state, voltage is always present on the system board as long as the system is plugged into an active AC outlet. You must disconnect the power cord and wait approximately 30 seconds for the power to drain to avoid damage to the internal components of the computer.

4. Grasp the top of the rear panel on the monitor head at the webcam slot and pull the panel off the monitor head at the connection points (1), and then slide the rear cover down the neck of the stand (2).

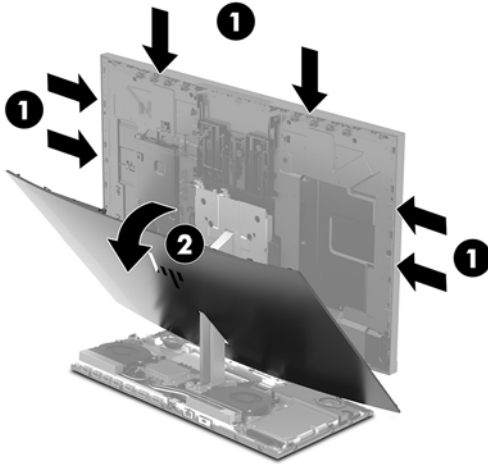

5. Remove the screws from the webcam blank (1), and then slide the blank back to remove it from the monitor head (2).

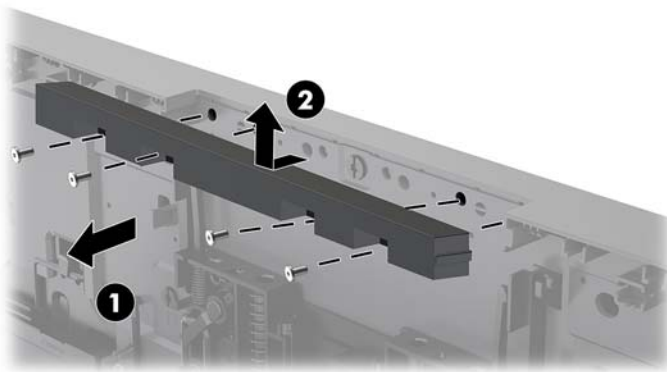

6. Snap the rear panel onto the monitor head.

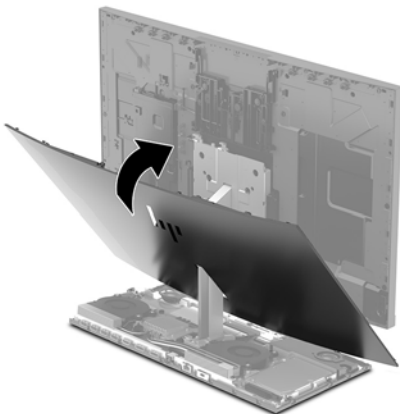

7. Insert the new webcam into the webcam slot on the monitor head and press the webcam down so that it engages the internal latches.
8. Reconnect the power cord and any external devices, and then turn on the computer.

A Electrostatic discharge

A discharge of static electricity from a finger or other conductor may damage system boards or other static-sensitive devices. This type of damage may reduce the life expectancy of the device.

Preventing electrostatic damage

To prevent electrostatic damage, observe the following precautions:

- Avoid hand contact by transporting and storing products in static-safe containers.
- Keep electrostatic-sensitive parts in their containers until they arrive at static-free workstations.
- Place parts on a grounded surface before removing them from their containers.
- Avoid touching pins, leads, or circuitry.
- Always be properly grounded when touching a static-sensitive component or assembly.

Grounding methods

Use one or more of the following methods when handling or installing electrostatic-sensitive parts:

- Use a wrist strap connected by a ground cord to a grounded workstation or computer chassis. Wrist straps are flexible straps with a minimum of 1 megohm +/- 10 percent resistance in the ground cords. To provide proper ground, wear the strap snug against the skin.
- Use heelstraps, toestraps, or bootstraps at standing workstations. Wear the straps on both feet when standing on conductive floors or dissipating floor mats.
- Use conductive field service tools.
- Use a portable field service kit with a folding static-dissipating work mat.

If you do not have any of the suggested equipment for proper grounding, contact an HP authorized dealer, reseller, or service provider.



NOTE: For more information on static electricity, contact an HP authorized dealer, reseller, or service provider.

B Computer operating guidelines, routine care, and shipping preparation

Computer operating guidelines and routine care

Follow these guidelines to properly set up and care for the computer and monitor:

- Keep the computer away from excessive moisture, direct sunlight, and extremes of heat and cold.
- Operate the computer on a sturdy, level surface. Leave a 10.2 cm (4 in) clearance on all vented sides of the computer and above the monitor to permit the required airflow.
- Never restrict the airflow into the computer by blocking any vents or air intakes. Do not place the keyboard, with the keyboard feet down, directly against the front of the desktop unit as this also restricts airflow.
- Never operate the computer with any of the access panels or any of the expansion card slot covers removed.
- Do not stack computers or place computers so near each other that they are subject to each other's recirculated or preheated air.
- If the computer is to be operated within a separate enclosure, intake and exhaust ventilation must be provided on the enclosure, and the same operating guidelines listed above will still apply.
- Keep liquids away from the computer and keyboard.
- Never cover the ventilation slots with any type of material.
- Install or enable power management functions of the operating system or other software, including sleep states.
- Turn off the computer before you do any of the following:
 - Wipe the exterior of the computer with a soft, damp cloth as needed. Using cleaning products may discolor or damage the finish.
 - Wipe the screen with a soft, clean antistatic cloth. For more difficult cleaning situations, use a 50/50 mix of water and Isopropyl alcohol. Spray the cleaner onto a cloth and use the damp cloth to gently wipe the screen surface. Never spray the cleaner directly on the screen surface. It may run behind the bezel and damage the electronics.
 - Occasionally clean the air vents on all vented sides of the computer. Lint, dust, and other foreign matter can block the vents and limit the airflow.
- Do not use cleaners that contain any petroleum based materials such as benzene, thinner, or any volatile substance to clean the screen or cabinet. These chemicals may damage the computer.

Shipping preparation

Follow these suggestions when preparing to ship the computer:

1. Back up the hard drive files to an external storage device. Be sure that the backup media is not exposed to electrical or magnetic impulses while stored or in transit.



NOTE: The hard drive locks automatically when the system power is turned off.

2. Remove and store all removable media.
3. Turn off the computer and external devices.
4. Disconnect the power cord from the AC outlet, and then from the computer.
5. Disconnect the system components and external devices from their power sources, and then from the computer.



NOTE: Ensure that all boards are seated properly and secured in the board slots before shipping the computer.

6. Pack the system components and external devices in their original packing boxes or similar packaging with sufficient packing material to protect them.

C Accessibility

HP designs, produces, and markets products and services that can be used by everyone, including people with disabilities, either on a stand-alone basis or with appropriate assistive devices.

Supported assistive technologies

HP products support a wide variety of operating system assistive technologies and can be configured to work with additional assistive technologies. Use the Search feature on your device to locate more information about assistive features.



NOTE: For additional information about a particular assistive technology product, contact customer support for that product.

Contacting support

We are constantly refining the accessibility of our products and services and welcome feedback from users. If you have an issue with a product or would like to tell us about accessibility features that have helped you, please contact us at (888) 259-5707, Monday through Friday, 6 a.m. to 9 p.m. Mountain Time. If you are deaf or hard-of-hearing and use TRS/VRS/WebCapTel, contact us if you require technical support or have accessibility questions by calling (877) 656-7058, Monday through Friday, 6 a.m. to 9 p.m. Mountain Time.

Index

A

- access panels
 - removal 15
 - replacement 15
- accessibility 34
- additional information 14

B

- base unit rear components 2
- base unit side components 2
- base unit top components 1
- battery replacement 23

C

- components
 - base unit 1, 2
 - FHD webcam 4
 - internal 21
 - IR webcam 3
 - monitor 3
- computer operating guidelines 32

E

- electrostatic discharge, preventing damage 31

F

- FHD webcam components 4

G

- grounding methods 31

H

- hard drive
 - removal 25
 - replacement 25

I

- installation guidelines 14
- internal components 21
- IR webcam components 3

K

- keyboard
 - synchronizing 13

M

- M.2 SSD
 - installation 26
 - removal 26
- memory
 - installing 22
 - locations 22
 - removing 22
 - specifications 21
- monitor head
 - adjustment 10
 - front components 3
 - installing 5
 - removal 17
 - replacement 17
- mouse
 - synchronizing 13

P

- power supply connection 8

S

- secondary monitor connection 11
- security cable 9
- serial and product number
 - locations 4
- setup 5
- shipping preparation 33
- synchronizing wireless keyboard and mouse 13

V

- ventilation guidelines 32

W

- warnings and cautions 14
- webcam
 - components 3
 - installation 28
 - operation 12
 - removal 28
 - replacement 28
 - using 12
- Windows Hello 12