

WF-C579R Series User's Guide

Contents

About This Manual

Introduction to the Manuals.	8
Using the Manual to Search for Information.	8
Marks and Symbols.	10
Descriptions Used in this Manual.	10
Operating System References.	10

Important Instructions

Safety Instructions.	12
Printer Advisories and Warnings.	13
Advisories and Warnings for Setting Up the Printer.	13
Advisories and Warnings for Using the Printer.	14
Advisories and Warnings for Transporting or Storing the Printer.	14
Advisories and Warnings for Using the Printer with a Wireless Connection.	14
Advisories and Warnings for Using the Touchscreen.	14
Protecting Your Personal Information.	15

Printer Basics

Part Names and Functions.	16
Control Panel.	20
Basic Screen Configuration.	21
Icons displayed in the LCD Screen.	22
Touch Screen Operations.	23
Entering Characters.	24
Job/Status Screen Configuration.	25
Viewing Animations.	25

Preparing the Printer

Loading Papers.	27
Available Paper and Capacities.	27
Loading Paper in the Paper Cassette.	32
Loading Paper in the Rear Paper Feed.	34
Loading Envelopes and Precautions.	37
Loading Long Papers.	38
List of Paper Type.	38
Placing Originals.	39
Available Originals for the ADF.	39
Placing Originals on the ADF.	39
Placing Originals on the Scanner Glass.	42
Inserting an External USB Device.	44

Inserting and Removing an External USB Device.	44
Accessing an External USB Device From a Computer.	44
Using an Email Server.	45
Configuring Mail Server.	45
Email Server Setting Items.	46
Checking an Email Server Connection.	47
Messages Displayed During Connection Check.	47
Managing Contacts.	49
Starting from Importing Contacts from Another Epson Printer.	49
Registering or Editing Contacts.	49
Registering or Editing Grouped Contacts.	50
Registering Frequently Used Contacts.	51
Register Contacts on a Computer.	51
Backing up Contacts using a Computer.	51
Setting a Shared Folder.	52
Checking the Computer Name.	52
Enabling the Sharing Setting.	52
Creating a Shared Folder.	53
Registering the Shared Folder in Contacts.	54
Registering Your Favorite Settings as a Preset.	55
Menu Options for Presets.	55
Menu Options for Settings.	55
Menu Options for General Settings.	55
Menu Options for Print Counter.	65
Menu Options for Supply Status.	65
Menu Options for Maintenance.	66
Menu Options for Language.	66
Menu Options for Printer Status/Print.	67
Menu Options for Contacts Manager.	67
Menu Options for User Settings.	68
Menu Options for Authentication Device Status.	68
Menu Options for Epson Open Platform Information.	68
Saving Power.	68
Saving Power - Control Panel.	69

Fax Settings

Before Using Fax Features.	70
Connecting to a Phone Line.	70
Compatible Telephone Lines.	70
Connecting the Printer to a Phone Line.	71
Connecting Your Phone Device to the Printer.	72

Contents

Making the Printer Ready to Send and Receive Faxes (Using Fax Setting Wizard)	74
Making Settings Individually for Printer's Fax Features.	76
Setting Receive Mode.	76
Making Settings When You Connect an External Phone Device.	78
Making Print Settings to Receive Faxes.	79
Making Settings to Save and Forward Received Faxes.	79
Making Settings for Blocking Junk Faxes.	86
Making Settings to Send and Receive Faxes on a Computer.	87
Menu Options for Fax Settings.	88
Quick Operation Button Menu.	88
Send Settings Menu.	88
Receive Settings Menu.	89
Report Settings Menu.	94
Basic Settings Menu.	94
Security Settings Menu.	96
Check Fax Connection.	97
Fax Setting Wizard.	97
Network Settings	
Network Connection Types.	98
Ethernet Connection.	98
Wi-Fi Connection.	99
Wi-Fi Direct (Simple AP) Connection.	99
Connecting to a Computer.	100
Connecting to a Smart Device.	101
Connecting to a smart device over a wireless router.	101
Connecting to an iPhone or iPad (iOS devices) using Wi-Fi Direct.	101
Connecting to Android Devices using Wi-Fi Direct.	104
Connecting to Devices other than iOS and Android using Wi-Fi Direct.	106
Making Wi-Fi Settings from the Printer.	110
Making Wi-Fi Settings by Entering the SSID and Password.	110
Making Wi-Fi Settings by Push Button Setup (WPS).	111
Making Wi-Fi Settings by PIN Code Setup (WPS).	112
Making Advanced Network Settings.	113
Checking the Network Connection Status.	115
Network Icon.	115
Checking Detailed Network Information from the Control Panel.	115

Printing a Network Connection Report.	116
Printing a Network Status Sheet.	122
Replacing or Adding New Wireless Routers.	123
Changing the Connection Method to a Computer.	123
Changing the Network Connection to Ethernet from the Control Panel.	124
Changing the Wi-Fi Direct (Simple AP) Settings.	124
Disabling Wi-Fi from the Control Panel.	125
Disconnecting Wi-Fi Direct (Simple AP) Connection from the Control Panel.	125
Restoring the Network Settings from the Control Panel.	126

Printing

Printing from the Printer Driver on Windows.	127
Accessing the Printer Driver.	127
Printing Basics.	127
Printing on 2-Sides.	129
Printing Several Pages on One Sheet.	130
Printing and Stacking in Page Order (Reverse Order Printing).	131
Printing a Reduced or Enlarged Document.	131
Printing One Image on Multiple Sheets for Enlargement (Creating a Poster).	132
Printing with a Header and Footer.	138
Printing a Watermark.	139
Printing Password-Protected Files.	140
Printing Multiple Files Together.	140
Printing Using the Color Universal Print Feature.	141
Adjusting the Print Color.	142
Printing to Emphasize Thin Lines.	142
Printing Clear Bar Codes.	143
Canceling Printing.	143
Menu Options for the Printer Driver.	144
Printing from the PostScript Printer Driver on Windows.	146
Menu Options for the PostScript Printer Driver	147
Canceling Printing.	148
Printing from the Printer Driver on Mac OS.	149
Printing Basics.	149
Printing on 2-Sides.	150
Printing Several Pages on One Sheet.	151
Printing and Stacking in Page Order (Reverse Order Printing).	151
Printing a Reduced or Enlarged Document.	152
Adjusting the Print Color.	153
Canceling Printing.	153
Menu Options for the Printer Driver.	153

Contents

Making Operation Settings for the Mac OS Printer Driver.	155	Sending Faxes On Demand (Using Polling Send/Bulletin Board Box).	194
Printing from the PostScript Printer Driver on Mac OS.	156	Various Ways of Sending Faxes.	196
Menu Options for the PostScript Printer Driver	157	Receiving Faxes on the Printer.	200
Canceling Printing.	158	Receiving Incoming Faxes.	201
Printing Files from a Memory Device.	158	Receiving Faxes by Making a Phone Call.	202
Printing JPEG Files from a Memory Device.	158	Saving and Forwarding Received Faxes.	204
Printing PDF or TIFF Files from a Memory Device.	159	Viewing Received Faxes Saved in the Printer on the LCD Screen.	205
Menu Options for Memory Device.	160	Menu Options for Faxing.	206
Printing from Smart Devices.	162	Recipient.	206
Using Epson iPrint.	162	Fax Settings.	206
Using Epson Print Enabler.	163	More.	208
Using AirPrint.	164	Menu Options for Fax Box.	209
Canceling Ongoing or Queued Jobs.	165	Inbox/Confidential.	209
Copying		Stored Documents.	211
Copying Basics.	166	Polling Send/Board.	212
Copying on 2-Sides.	166	Checking the Status or Logs for Fax Jobs.	214
Copying Multiple Originals onto One Sheet.	167	Displaying Information when Received Faxes are Unprocessed (Unread/Not Printed/Not Saved/Not Forwarded).	214
Basic Menu Options for Copying.	167	Checking Fax Jobs in Progress.	216
Advanced Menu Options for Copying.	168	Checking the Fax Job History.	216
Scanning		Reprinting Received Documents.	216
Scanning Using the Control Panel.	171	Sending a Fax from a Computer.	217
Scanning to a Network Folder or FTP Server.	171	Sending Documents Created Using an Application (Windows).	217
Scanning to an Email.	174	Sending Documents Created Using an Application (Mac OS).	219
Scanning Using the Settings Registered on the Computer (Document Capture Pro).	177	Receiving Faxes on a Computer.	220
Scanning to a Memory Device.	180	Saving Incoming Faxes on a Computer.	221
Scanning to the Cloud.	182	Canceling the Feature that Saves Incoming Faxes to the Computer.	221
Scanning Using WSD.	184	Checking for New Faxes (Windows).	222
Scanning from a Computer.	186	Checking for New Faxes (Mac OS).	223
Authenticating Users on Epson Scan 2 when Using Access Control.	186	Replacing Ink Supply Units and Other Consumables	
Scanning Using Epson Scan 2.	186	Checking the Status of the Remaining Ink and the Maintenance Box.	224
Scanning from Smart Devices.	189	Checking the Status of the Remaining Ink and the Maintenance Box - Control Panel.	224
Installing Epson iPrint.	189	Checking the Status of the Remaining Ink and the Maintenance Box - Windows.	224
Scanning Using Epson iPrint.	189	Checking the Status of the Remaining Ink and the Maintenance Box - Mac OS.	224
Faxing		Ink Supply Unit Codes.	225
Before Using Fax Features.	191	Ink Supply Unit Handling Precautions.	225
Sending Faxes Using the Printer.	191	Replacing Ink Supply Units.	226
Sending Faxes Using the Control Panel.	191		
Sending Faxes Dialing from the External Phone Device.	194		

Contents

Maintenance Box Code.	227
Maintenance Box Handling Precautions.	227
Replacing a Maintenance Box.	227
Temporarily Printing with Black Ink.	228
Temporarily Printing with Black Ink - Control Panel.	228
Temporarily Printing with Black Ink - Windows	229
Conserving Black Ink when the Black Ink Is Low (for Windows Only).	230

Maintaining the Printer

Checking and Cleaning the Print Head.	231
Checking and Cleaning the Print Head - Control Panel.	231
Checking and Cleaning the Print Head - Windows.	232
Checking and Cleaning the Print Head - Mac OS.	232
Aligning Ruled Lines.	232
Cleaning the Paper Path for Ink Smears.	233
Cleaning the ADF.	233
Cleaning the Scanner Glass.	236

Network Service and Software Information

Application for Configuring Printer Operations (Web Config).	237
Running Web Config on a Web Browser.	237
Running Web Config on Windows.	238
Running Web Config on Mac OS.	238
Application for Scanning Documents and Images (Epson Scan 2).	238
Adding the Network Scanner.	239
Application for Configuring Scanning from the Computer (Document Capture Pro).	240
Application for Configuring Fax Operations and Sending Faxes (FAX Utility).	240
Application for Sending Faxes (PC-FAX Driver).	241
Application for Printing Web Pages (E-Web Print)(for Windows Only).	241
Application for Configuring Multiple Devices (EpsonNet Config).	242
Software Update Tools (EPSON Software Updater).	242
Installing the Latest Applications.	243
Installing a PostScript Printer Driver.	244

Installing a PostScript Printer Driver - Windows.	244
Installing a PostScript Printer Driver - Mac OS.	244
Installing the Epson Universal Printer Driver (for Windows Only).	245
Uninstalling Applications.	245
Uninstalling Applications - Windows.	246
Uninstalling Applications - Mac OS.	246
Printing Using a Network Service.	247

Solving Problems

Checking the Printer Status.	248
Checking Messages on the LCD Screen.	248
Error Code on the Status Menu.	250
Checking the Printer Status - Windows.	255
Checking the Printer Status - Mac OS.	255
Checking the Software Status.	256
Removing Jammed Paper.	256
Paper Does Not Feed Correctly.	256
Paper Jams.	257
Paper Feeds at a Slant.	257
Several Sheets of Paper are Fed at a Time.	257
Paper Does Not Feed from the Optional Paper Cassette Unit.	257
Paper Out Error Occurs.	257
Original Does Not Feed in the ADF.	257
Power and Control Panel Problems.	258
Power Does Not Turn On.	258
Power Does Not Turn Off.	259
Power Turns Off Automatically.	259
LCD Screen Gets Dark.	259
Touch Screen Does Not Respond.	259
Cannot Operate from the Control Panel.	259
Cannot Print from a Computer.	259
Checking the Connection (USB).	259
Checking the Connection (Network).	260
Checking the Software and Data.	260
Checking the Printer Status from the Computer (Windows).	262
Checking the Printer Status from the Computer (Mac OS).	263
When You Cannot Make Network Settings.	263
Cannot Connect from Devices Even Though Network Settings are No Problems.	264
Checking the SSID Connected to the Printer.	265
Checking the SSID for the Computer.	266
Cannot Print from an iPhone or iPad.	267
Printout Problems.	267

Contents

Adjusting the Print Quality.	267	Moiré Patterns (Web-Like Shadows) Appear. . .	280
Adjusting Print Quality per Paper.	268	Cannot Scan the Correct Area on the	
Printout is Scuffed or Color is Missing.	269	Scanner Glass.	281
Banding or Unexpected Colors Appear.	270	Text is Not Recognized Correctly when	
Colored Banding Appears at Intervals of		Saving as a Searchable PDF.	281
Approximately 3.3 cm.	270	Cannot Solve Problems in the Scanned Image. .	281
Blurry Prints, Vertical Banding, or		Cannot Save Scanned Images to the Shared Folder	282
Misalignment.	271	Checking Messages on the Printer.	282
Print Quality is Poor.	271	Saving the Scanned Images Takes a Long Time. .	284
Paper Is Smearred or Scuffed.	272	Switch Between Private Network and Public	
Paper is Smearred During Automatic 2-Sided		Network.	284
Printing.	273	Other Scanning Problems.	287
Printed Photos are Sticky.	273	Scanning Speed Is Slow.	287
Images or Photos are Printed in Unexpected		Cannot Send the Scanned Image by Email. . . .	287
Colors.	274	Scanning Stops when Scanning to PDF/ Multi-TIFF.	287
The Position, Size, or Margins of the Printout		Problems when Sending and Receiving Faxes. . .	287
Are Incorrect.	274	Cannot Send or Receive Faxes.	287
Printed Characters Are Incorrect or Garbled. . .	274	Cannot Send Faxes.	289
The Printed Image Is Inverted.	275	Cannot Send Faxes to a Specific Recipient. . . .	289
Mosaic-Like Patterns in the Prints.	275	Cannot Send Faxes at a Specified Time.	290
Unintentionally Printing on 2-Sides.	275	Cannot Receive Faxes.	290
Uneven Colors, Smears, Dots, or Straight		Cannot Save Received Faxes to a Memory	
Lines Appear in the Copied Image.	275	Device.	290
Moiré (Cross-Hatch) Patterns Appear in the		Memory Full Error Occurs.	290
Copied Image.	276	Sent Fax Quality Is Poor.	291
An Image of the Reverse Side of the Original		Faxes Are Sent at the Wrong Size.	291
Appears in the Copied Image.	276	Received Fax Quality Is Poor.	292
The Printout Problem Could Not be Cleared. . .	276	Received Faxes Are Not Printed.	292
Other Printing Problems.	276	Pages are Blank or only a Small Amount of	
Printing Is Too Slow.	276	Text is Printed on the Second Page in	
Printing Slows Down Dramatically During		Received Faxes.	292
Continuous Printing.	277	Other Faxing Problems.	292
Cannot Cancel Printing from a Computer		Cannot Make Calls on the Connected	
Running Mac OS X v10.6.8.	277	Telephone.	292
PostScript Printer Driver Problems.	277	Answering Machine Cannot Answer Voice	
Printer Does Not Print While Using		Calls.	293
PostScript Printer Driver.	278	Sender's Fax Number Not Displayed on	
Printer Does Not Print Correctly While		Received Faxes or the Number Is Wrong.	293
Using PostScript Printer Driver.	278	Other Problems.	293
Print Quality Is Poor While Using PostScript		Slight Electric Shock when Touching the	
Printer Driver.	278	Printer.	293
Printing Is Too Slow While Using PostScript		Operation Sounds Are Loud.	293
Printer Driver.	278	The Date and Time Are Incorrect.	293
Cannot Start Scanning.	278	Memory Device Is not Recognized.	294
Scanned Image Problems.	279	Cannot Save Data to a Memory Device.	294
Uneven Colors, Dirt, Spots, and so on Appear		Forgot Your Password.	294
when Scanning from the Scanner Glass.	279	Application Is Blocked by a Firewall (for	
Straight Lines Appear when Scanning from		Windows Only).	294
ADF.	279	"x" Is Displayed on the Photo Selection Screen. .	294
The Image Quality Is Rough.	280		
Offset Appears in the Background of Images. . .	280		
Text is Blurred.	280		

Appendix

Technical Specifications.	295
Printer Specifications.	295
Scanner Specifications.	296
Interface Specifications.	296
Fax Specifications.	296
Network Function List.	297
Wi-Fi Specifications.	298
Ethernet Specifications.	298
Security Protocol.	299
PostScript Level 3 Compatibility.	299
Supported Third Party Services.	299
External USB Device Specifications.	299
Supported Data Specifications.	300
Dimensions.	300
Electrical Specifications.	301
Environmental Specifications.	301
Installation Location and Space.	302
System Requirements.	303
Font Information.	304
Available Fonts for PostScript.	304
Available Fonts for PCL (URW).	305
List of Symbol Sets.	306
Installing the Optional Units.	309
Optional Paper Cassette Unit Code.	309
Installing the Optional Paper Cassette Unit.	309
Regulatory Information.	314
Standards and Approvals.	314
German Blue Angel.	315
Restrictions on Copying.	315
Transporting and Storing the Printer.	316
Copyright.	319
Trademarks.	320
Where to Get Help.	322
Technical Support Web Site.	322
Contacting Epson Support.	322

About This Manual

Introduction to the Manuals

The following manuals are supplied with your Epson printer. As well as the manuals, check the various types of help information available from the printer itself or from the Epson software applications.

- Important Safety Instructions (paper manual)
Provides you with instructions to ensure the safe use of this printer.
- Start Here (paper manual)
Provides you with information on setting up the printer and installing the software.
- User's Guide (digital manual)
This manual. Provides overall information and instructions on using the printer, on network settings when using the printer on a network, and on solving problems.
- Administrator's Guide (digital manual)
Provides network administrators with information on management and printer settings such as the e-mail notification feature.

You can obtain the latest versions of the above manuals with the following methods.

- Paper manual
Visit the Epson Europe support website at <http://www.epson.eu/Support>, or the Epson worldwide support website at <http://support.epson.net/>.
- Digital manual
Start EPSON Software Updater on your computer. EPSON Software Updater checks for available updates of Epson software applications and the digital manuals, and allows you to download the latest ones.

Related Information

- ➔ [“Software Update Tools \(EPSON Software Updater\)” on page 242](#)

Using the Manual to Search for Information

The PDF manual allows you to search for information you are looking for by keyword, or jump directly to specific sections using the bookmarks. You can also print only the pages you need. This section explains how to use a PDF manual that has been opened in Adobe Reader X on your computer.

About This Manual

Searching by keyword

Click **Edit > Advanced Search**. Enter the keyword (text) for information you want to find in the search window, and then click **Search**. Hits are displayed as a list. Click one of the displayed hits to jump to that page.

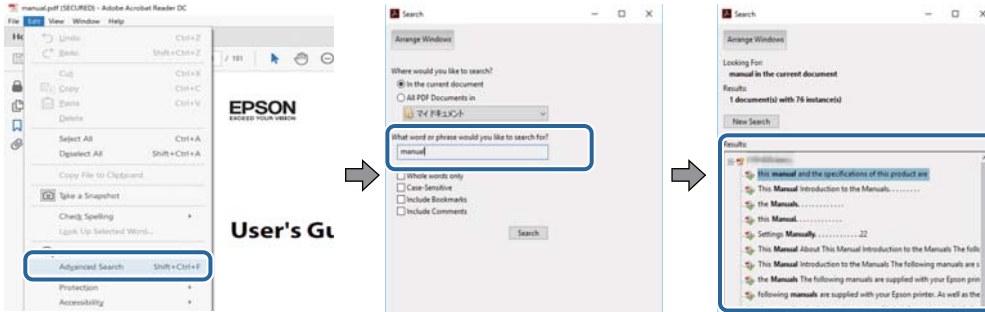

Jumping directly from bookmarks

Click a title to jump to that page. Click + or > to view the lower level titles in that section. To return to the previous page, perform the following operation on your keyboard.

- ❑ Windows: Hold down **Alt**, and then press **←**.
- ❑ Mac OS: Hold down the command key, and then press **←**.

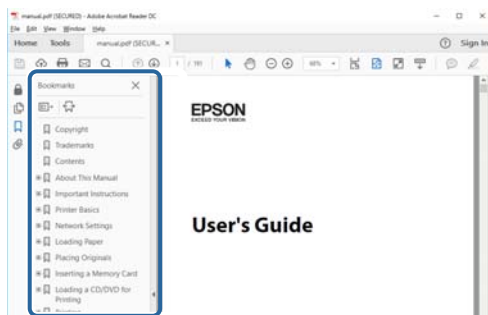

Printing only the pages you need

You can extract and print only the pages you need. Click **Print** in the **File** menu, and then specify the pages you want to print in **Pages in Pages to Print**.

- ❑ To specify a series of pages, enter a hyphen between the start page and the end page.
Example: 20-25
- ❑ To specify pages that are not in series, divide the pages with commas.
Example: 5, 10, 15

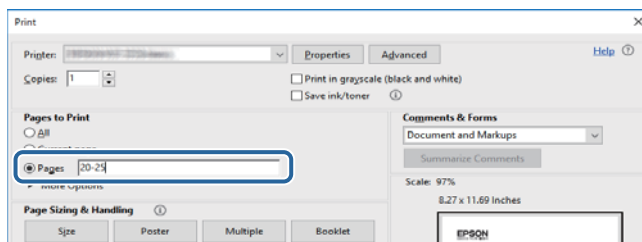

Marks and Symbols

**Caution:**

Instructions that must be followed carefully to avoid bodily injury.

**Important:**

Instructions that must be observed to avoid damage to your equipment.

Note:

Provides complementary and reference information.

Related Information

➔ Links to related sections.

Descriptions Used in this Manual

- Screenshots of the printer driver and the Epson Scan 2 (scanner driver) screens are from Windows 10 or macOS High Sierra. The content displayed on the screens varies depending on the model and situation.
- Illustrations used in this manual are examples only. Although there may be slight differences depending on the model, the method of operation is the same.
- Some of the menu items on the LCD screen vary depending on the model and settings.
- You can read the QR code using dedicated app.

Operating System References

Windows

In this manual, terms such as "Windows 10", "Windows 8.1", "Windows 8", "Windows 7", "Windows Vista", "Windows XP", "Windows Server 2016", "Windows Server 2012 R2", "Windows Server 2012", "Windows Server 2008 R2", "Windows Server 2008", "Windows Server 2003 R2", and "Windows Server 2003" refer to the following operating systems. Additionally, "Windows" is used to refer to all versions.

- Microsoft® Windows® 10 operating system
- Microsoft® Windows® 8.1 operating system
- Microsoft® Windows® 8 operating system
- Microsoft® Windows® 7 operating system
- Microsoft® Windows Vista® operating system
- Microsoft® Windows® XP operating system
- Microsoft® Windows® XP Professional x64 Edition operating system
- Microsoft® Windows Server® 2016 operating system
- Microsoft® Windows Server® 2012 R2 operating system

About This Manual

- Microsoft® Windows Server® 2012 operating system
- Microsoft® Windows Server® 2008 R2 operating system
- Microsoft® Windows Server® 2008 operating system
- Microsoft® Windows Server® 2003 R2 operating system
- Microsoft® Windows Server® 2003 operating system

Mac OS

In this manual, "Mac OS" is used to refer to macOS High Sierra, macOS Sierra, OS X El Capitan, OS X Yosemite, OS X Mavericks, OS X Mountain Lion, Mac OS X v10.7.x, and Mac OS X v10.6.8.

Important Instructions

Safety Instructions

Read and follow these instructions to ensure safe use of this printer. Make sure you keep this manual for future reference. Also, be sure to follow all warnings and instructions marked on the printer.

- ❑ Some of the symbols used on your printer are to ensure safety and proper use of the printer. Visit the following Web site to learn the meaning of the symbols.
<http://support.epson.net/symbols>
- ❑ Use only the power cord supplied with the printer and do not use the cord with any other equipment. Use of other cords with this printer or the use of the supplied power cord with other equipment may result in fire or electric shock.
- ❑ Be sure your AC power cord meets the relevant local safety standard.
- ❑ Never disassemble, modify, or attempt to repair the power cord, plug, printer unit, scanner unit, or options by yourself, except as specifically explained in the printer's manuals.
- ❑ Unplug the printer and refer servicing to qualified service personnel under the following conditions:
The power cord or plug is damaged; liquid has entered the printer; the printer has been dropped or the casing damaged; the printer does not operate normally or exhibits a distinct change in performance. Do not adjust controls that are not covered by the operating instructions.
- ❑ Place the printer near a wall outlet where the plug can be easily unplugged.
- ❑ Do not place or store the printer outdoors, near excessive dirt or dust, water, heat sources, or in locations subject to shocks, vibrations, high temperature or humidity.
- ❑ Take care not to spill liquid on the printer and not to handle the printer with wet hands.
- ❑ Keep the printer at least 22 cm away from cardiac pacemakers. Radio waves from this printer may adversely affect the operation of cardiac pacemakers.
- ❑ If the LCD screen is damaged, contact your dealer. If the liquid crystal solution gets on your hands, wash them thoroughly with soap and water. If the liquid crystal solution gets into your eyes, flush them immediately with water. If discomfort or vision problems remain after a thorough flushing, see a doctor immediately.
- ❑ Avoid using a telephone during an electrical storm. There may be a remote risk of electric shock from lightning.
- ❑ Do not use a telephone to report a gas leak in the vicinity of the leak.
- ❑ The printer is heavy and should not be lifted or carried by less than two people. Uninstall paper cassette 2 if it is installed. When lifting the printer, two or more people should assume the correct positions as shown below.

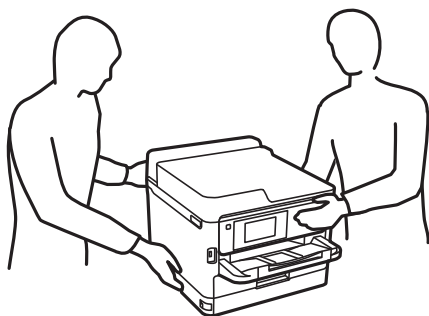

Important Instructions

- ❑ Be careful when you handle used ink supply units, as there may be some ink around the ink supply port.
 - ❑ If ink gets on your skin, wash the area thoroughly with soap and water.
 - ❑ If ink gets into your eyes, flush them immediately with water. If discomfort or vision problems continue after a thorough flushing, see a doctor immediately.
 - ❑ If ink gets into your mouth, see a doctor right away.
- ❑ Do not disassemble the ink supply unit and the maintenance box; otherwise ink may get into your eyes or on your skin.
- ❑ Do not shake ink supply units too vigorously; otherwise ink may leak from the ink supply units.
- ❑ Keep ink supply units and maintenance box out of the reach of children.

Printer Advisories and Warnings



Read and follow these instructions to avoid damaging the printer or your property. Make sure you keep this manual for future reference.

Advisories and Warnings for Setting Up the Printer

- ❑ Do not block or cover the vents and openings in the printer.
- ❑ Use only the type of power source indicated on the printer's label.
- ❑ Avoid using outlets on the same circuit as photocopiers or air control systems that regularly switch on and off.
- ❑ Avoid electrical outlets controlled by wall switches or automatic timers.
- ❑ Keep the entire computer system away from potential sources of electromagnetic interference, such as loudspeakers or the base units of cordless telephones.
- ❑ The power-supply cords should be placed to avoid abrasions, cuts, fraying, crimping, and kinking. Do not place objects on top of the power-supply cords and do not allow the power-supply cords to be stepped on or run over. Be particularly careful to keep all the power-supply cords straight at the ends and the points where they enter and leave the transformer.
- ❑ If you use an extension cord with the printer, make sure that the total ampere rating of the devices plugged into the extension cord does not exceed the cord's ampere rating. Also, make sure that the total ampere rating of all devices plugged into the wall outlet does not exceed the wall outlet's ampere rating.
- ❑ If you plan to use the printer in Germany, the building installation must be protected by a 10 or 16 amp circuit breaker to provide adequate short-circuit protection and over-current protection for the printer.
- ❑ When connecting the printer to a computer or other device with a cable, ensure the correct orientation of the connectors. Each connector has only one correct orientation. Inserting a connector in the wrong orientation may damage both devices connected by the cable.
- ❑ Place the printer on a flat, stable surface that extends beyond the base of the printer in all directions. The printer will not operate properly if it is tilted at an angle.
- ❑ Allow space above the printer so that you can fully raise the document cover.
- ❑ Leave enough space in front of the printer for the paper to be fully ejected.
- ❑ Avoid places subject to rapid changes in temperature and humidity. Also, keep the printer away from direct sunlight, strong light, or heat sources.

Important Instructions

Advisories and Warnings for Using the Printer

- ❑ Do not insert objects through the slots in the printer.
- ❑ Do not put your hand inside the printer during printing.
- ❑ Do not touch the white flat cable inside the printer.
- ❑ Do not use aerosol products that contain flammable gases inside or around the printer. Doing so may cause fire.
- ❑ Do not move the print head by hand; otherwise, you may damage the printer.
- ❑ Be careful not to trap your fingers when closing the scanner unit.
- ❑ Do not press too hard on the scanner glass when placing the originals.
- ❑ Always turn the printer off using the  button. Do not unplug the printer or turn off the power at the outlet until the  light stops flashing.
- ❑ If you are not going to use the printer for a long period, be sure to unplug the power cord from the electrical outlet.

Advisories and Warnings for Transporting or Storing the Printer

- ❑ When storing or transporting the printer, avoid tilting it, placing it vertically, or turning it upside down; otherwise ink may leak.
- ❑ Before transporting the printer, make sure that the print head is in the home (far right) position, and the ink supply units are installed.

Advisories and Warnings for Using the Printer with a Wireless Connection

- ❑ Radio waves from this printer may negatively affect the operation of medical electronic equipment, causing them to malfunction. When using this printer inside medical facilities or near medical equipment, follow directions from the authorized personnel representing the medical facilities, and follow all posted warnings and directions on the medical equipment.
- ❑ Radio waves from this printer may negatively affect the operation of automatically controlled devices such as automatic doors or fire alarms, and could lead to accidents due to malfunction. When using this printer near automatically controlled devices, follow all posted warnings and directions on these devices.

Advisories and Warnings for Using the Touchscreen

- ❑ The LCD screen may contain a few small bright or dark spots, and because of its features it may have an uneven brightness. These are normal and do not indicate that it is damaged in any way.
- ❑ Only use a dry, soft cloth for cleaning. Do not use liquid or chemical cleaners.
- ❑ The exterior cover of the touchscreen could break if it receives a heavy impact. Contact your dealer if the panel surface chips or cracks, and do not touch or attempt to remove the broken pieces.
- ❑ Press the touchscreen gently with your finger. Do not press force or operate with your nails.
- ❑ Do not use sharp objects such as ball point pens or sharp pencils to perform operations.

Important Instructions

- Condensation inside the touchscreen due to abrupt changes in temperature or humidity may cause performance to deteriorate.

Protecting Your Personal Information

When you give the printer to someone else or dispose of it, erase all the personal information stored in the printer's memory by selecting the menus on the control panel as described below.

Settings > General Settings > System Administration > Restore Default Settings > Clear All Data and Settings

Printer Basics

Part Names and Functions

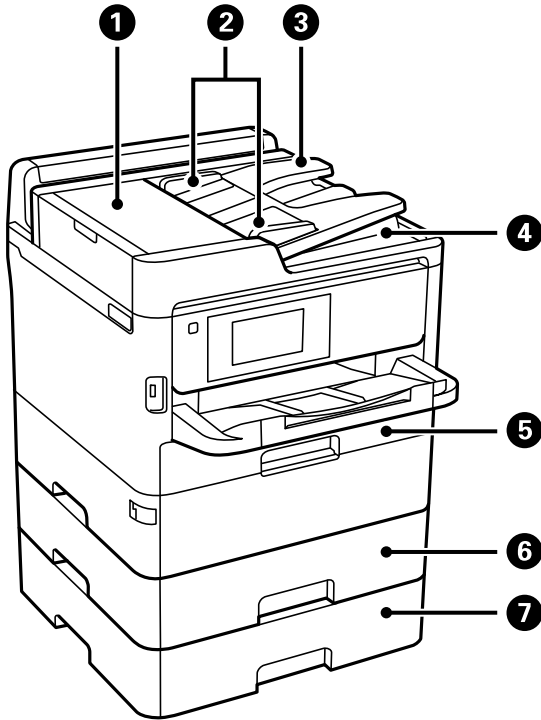

①	ADF (Automatic Document Feeder) cover (F)	Open when removing jammed originals in the ADF.
②	ADF edge guides	Feeds originals straight into the printer. Slide to the edges of the originals.
③	ADF input tray	Feeds originals automatically.
④	ADF output tray	Holds originals ejected from the ADF.
⑤	Paper cassette 1 (C1)	Loads paper.
⑥	Paper cassette 2 (C2)	Loads paper.
⑦	Paper cassette 3 (C3)	Optional paper cassette unit. Loads paper.

Printer Basics

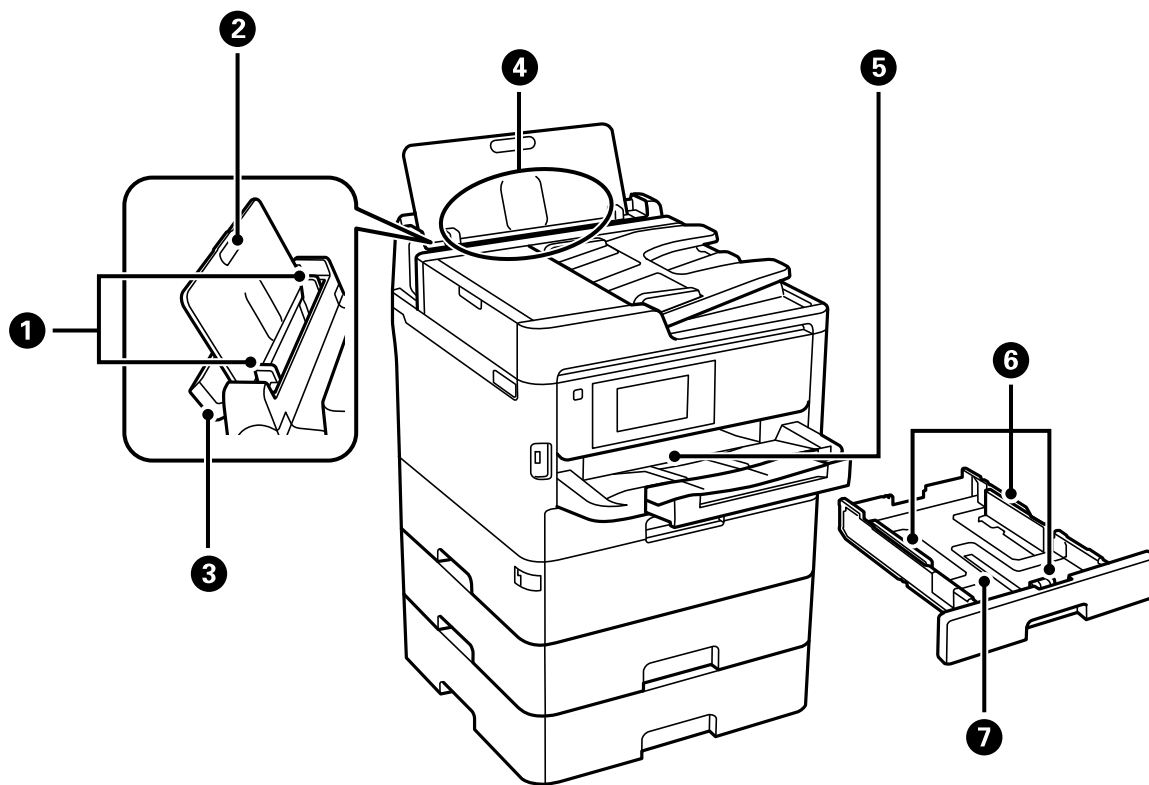

①	Edge guides	Feeds the paper straight into the printer. Slide to the edges of the paper.
②	Paper support	Supports loaded paper.
③	Feeder guard	Prevents foreign substance from entering the printer. Usually keep this guard closed.
④	Rear paper feed (B)	Loads paper.
⑤	Output tray	Holds the ejected paper.
⑥	Edge guides	Feeds the paper straight into the printer. Slide to the edges of the paper.
⑦	Paper cassette	Loads paper.

Printer Basics

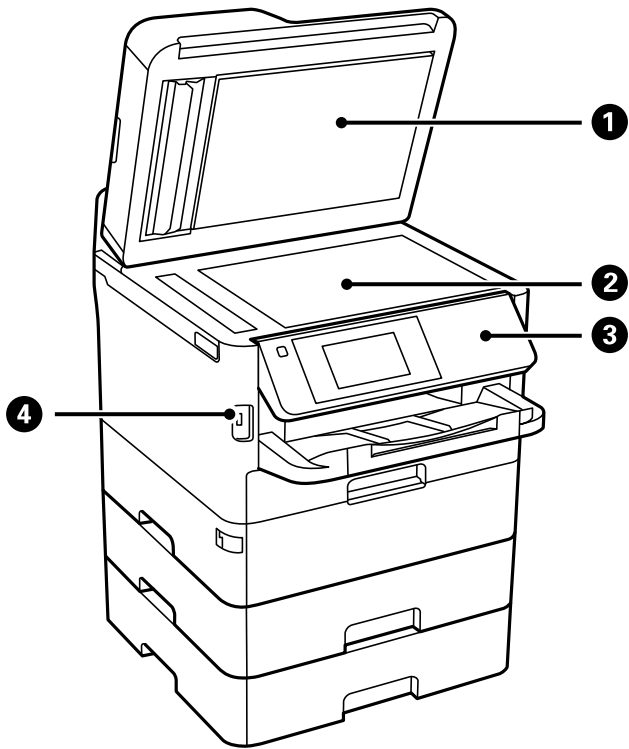

①	Document cover	Blocks external light while scanning.
②	Scanner glass	Place the originals.
③	Control panel	Operates the printer. You can change the angle of the control panel.
④	External interface USB port	Connects memory devices.

Printer Basics

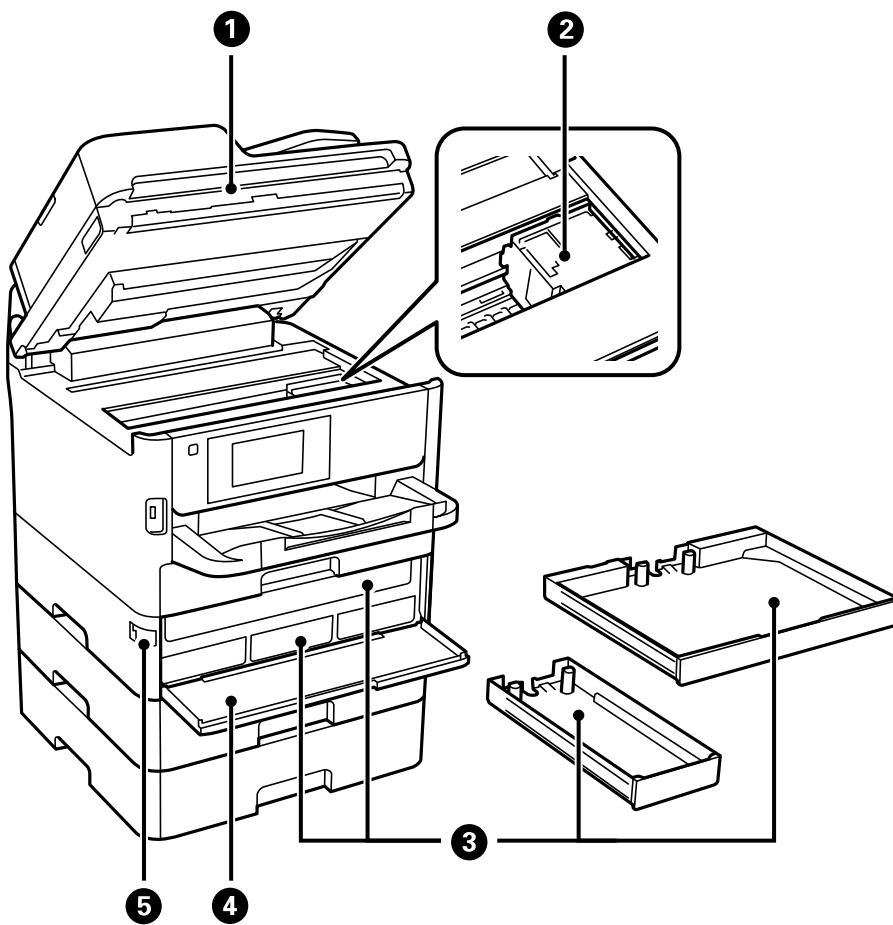

①	Scanner unit (J)	Scans placed originals. Open when removing jammed paper inside the printer.
②	Print head	Fires ink.
③	Ink supply unit tray	Sets an ink supply unit.
④	Front cover (A)	Open when replacing ink supply units.
⑤	Front cover lock	Locks the front cover.

Printer Basics

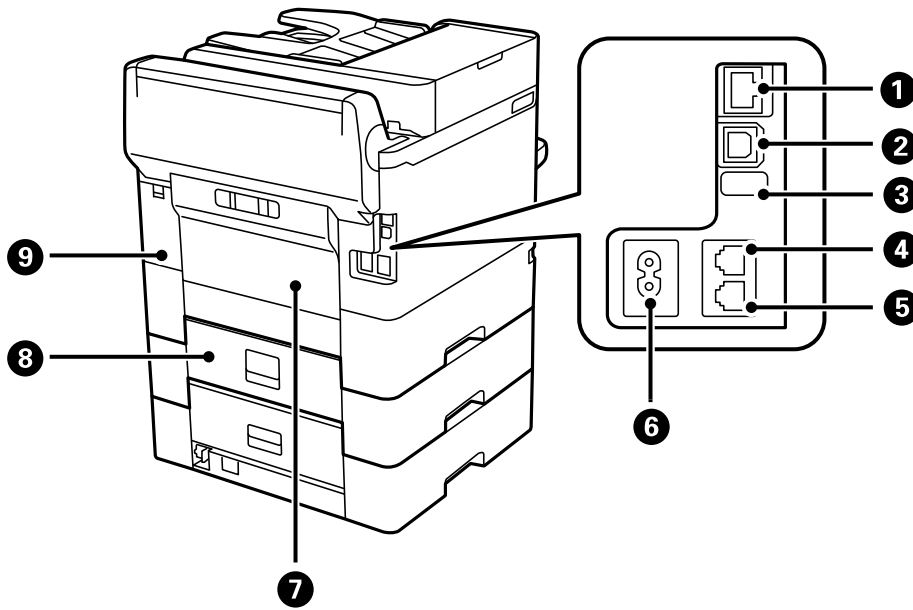

1	LAN port	Connects a LAN cable.
2	USB port	Connects a USB cable.
3	Service USB port	USB port for future use. Do not remove the sticker.
4	LINE port	Connects a phone line.
5	EXT. port	Connects external phone devices.
6	AC inlet	Connects the power cord.
7	Rear Cover (D)	Open when removing jammed paper.
8	Rear Cover (E)	Open when removing jammed paper.
9	Maintenance box cover (H)	Open when replacing the maintenance box.

Control Panel

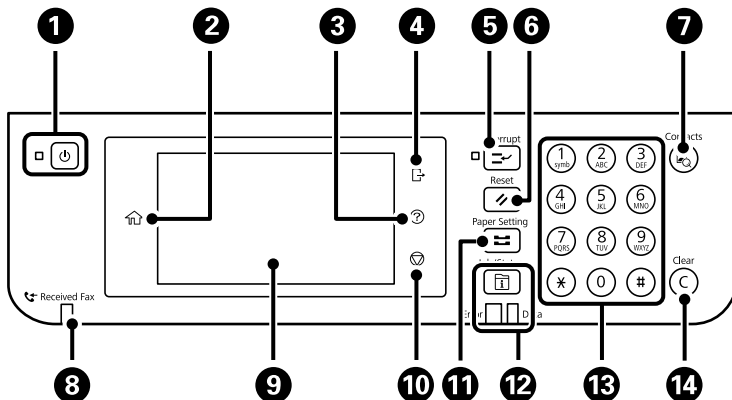

Printer Basics

1	Turns the printer on or off. Unplug the power cord after checking that the power light is off.
2	Displays the home screen.
3	Displays the Help screen. You can check solutions to problems from here.
4	Logs off from the printer when Access Control is enabled. When Access Control is disabled, this is also disabled.
5	Pauses the current printing job and allows you to interrupt another job. However, you cannot interrupt a new job from the computer. Press this button again to restart a paused job.
6	Resets the current settings to user default settings. If user default settings have not been made, resets to the factory default.
7	Displays the Contacts list. You can register, edit or delete the contacts.
8	Turns on when received documents that have not yet been read, printed, or saved, are stored in the printer's memory.
9	Displays menus and messages.
10	Stops the current operation.
11	Displays the Paper Setting screen. You can select the paper size and paper type settings for each paper source.
12	Displays the Job/Status menu. You can check the printer's status and job history. The error light on the left flashes or turns on when an error occurs. The data light on the right flashes when the printer is processing data. It turns on when there are queued jobs.
13	Enters numbers, characters, and symbols.
14	Clears number settings such as the number of copies.

Basic Screen Configuration

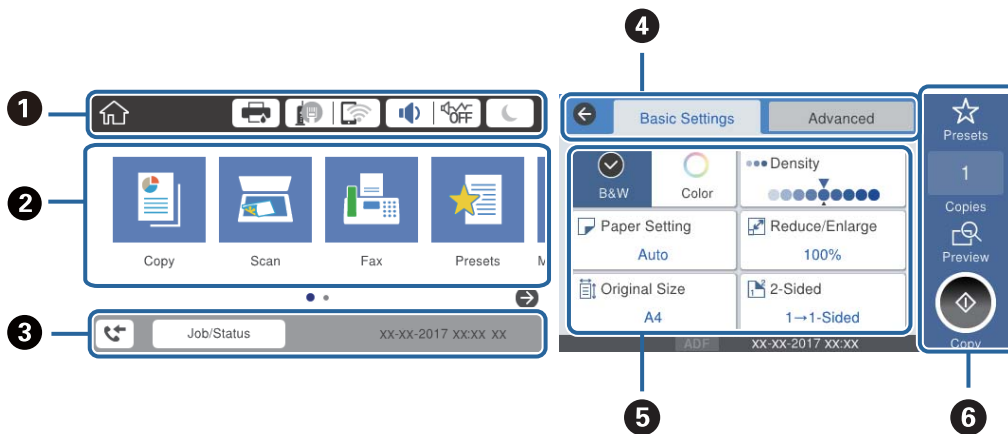









Printer Basics













①	Indicates items that have been setup for the printer as icons. Select each icon to check the current settings or access each setting menu.
②	Displays each menu. You can add or change the sequence.
③	Indicates an ongoing job and the printer's status. Select message to display the Job/Status menu. Displays the date and time when the printer is not working or there are no errors.
④	Switch tabs.
⑤	Indicates the setting items. Select each item to set or change the settings. The grayed out items are not available. Select the item to check why they are unavailable.
⑥	Execute the current settings. Available functions vary depending on each menu.

Icons displayed in the LCD Screen

The following icons are displayed on the LCD screen depending on the printer's status.

	Displays the Printer Status screen. You can check the approximate ink levels and the approximate service life of the maintenance box.
	Indicates the network connection status. Select the icon to check and change the current settings. This is the shortcut for the following menu. Settings > General Settings > Network Settings > Wi-Fi Setup
	The printer is not connected to a wired (Ethernet) network or unset it.
	The printer is connected to a wired (Ethernet) network.
	The printer is not connected to a wireless (Wi-Fi) network.
	The printer is searching for SSID, unset IP address, or having a problem with a wireless (Wi-Fi) network.
	The printer is connected to a wireless (Wi-Fi) network. The number of bars indicates the signal strength of the connection. The more bars there are, the stronger the connection.
	The printer is not connected to a wireless (Wi-Fi) network in Wi-Fi Direct (Simple AP) mode.
	The printer is connected to a wireless (Wi-Fi) network in Wi-Fi Direct (Simple AP) mode.

Printer Basics



	<p>Displays the Device Sound Settings screen. You can set Mute and Quiet Mode.</p> <p>You can also access the Sound menu from this screen. This is the shortcut for the following menu.</p> <p>Settings > General Settings > Basic Settings > Sound</p>
 	<p>Indicates whether or not Quiet Mode is set for the printer. When this feature is enabled, the noise made by printer operations is reduced, but print speed may slow down. However, noises may not be reduced depending on the selected paper type and print quality.</p>
	<p>Indicates that Mute is set for the printer.</p>
	<p>Select the icon to enter sleep mode. When the icon is grayed out, the printer cannot enter sleep mode.</p>
	<p>Indicates that the user restriction feature is enabled. Select this icon to log in to the printer. You need to select a user name and then enter a password. Contact your printer administrator for login information.</p>
	<p>Indicates that a user with access permission has logged in.</p> <p>Select the icon to logout.</p>
	<p>Displays the Fax Data Information screen.</p>
	<p>Indicates that the settings have been changed from the user default or the factory default.</p>
	<p>Indicates that there is additional information. Select the icon to displays the message.</p>
	<p>Indicates a problem with the items. Select the icon to check how to solve the problem.</p>
	<p>Indicates that there is data that has not yet been read, printed, or saved. The number displayed indicates the number of data items.</p>

Related Information

- ➔ [“Network Settings” on page 61](#)
- ➔ [“Sound:” on page 56](#)

Touch Screen Operations

The touchscreen is compatible with the following operations.

<p>Tap</p>		<p>Press or select the items or the icons.</p>
<p>Flick</p>		<p>Scroll the screen swiftly.</p>

Printer Basics

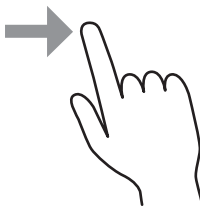
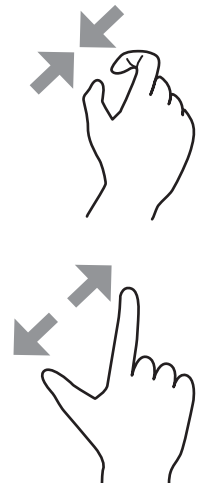
Slide		Hold and move the items around.
Pinch in Pinch out		Zoom in or zoom out of the preview image on the control panel.

Entering Characters

You can enter characters and symbols by using on-screen keyboard when you register a contact, make network settings, and so on.

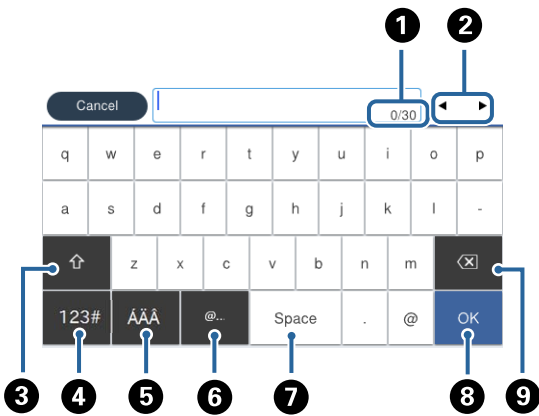

Note:

Available icons vary depending on the setting item.

1	Indicates the character count.
2	Moves the cursor to the input position.
3	Switches between upper case and lower case or numbers and symbols.
4	Switches the character type. You can enter alphanumerics and symbols.
5	Switches the character type. You can enter alphanumerics and special characters such as umlauts and accents.

Printer Basics

6	Enters frequently used email domain addresses or URLs by simply selecting the item.
7	Enters a space.
8	Enters character.
9	Deletes a character to the left.

Job/Status Screen Configuration

Press the  button to display the Job/Status menu. You can check the status of the printer or the jobs.

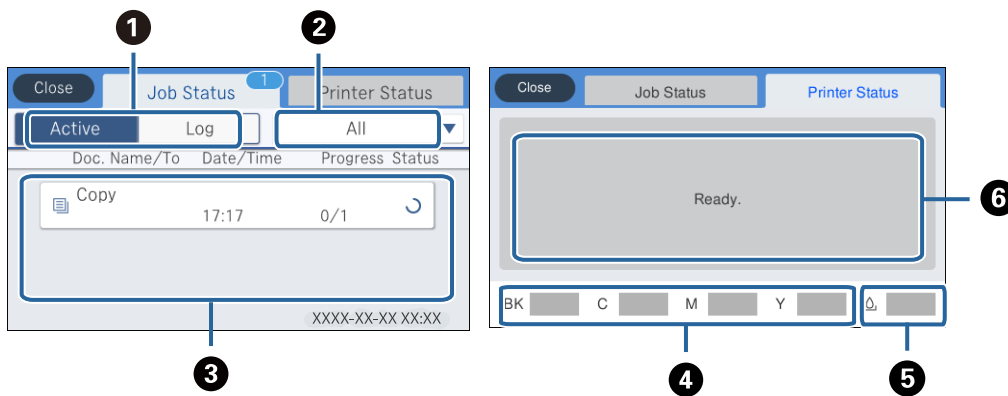

1	Switches the displayed lists.
2	Filter the jobs by functional.
3	When Active is selected, displays the list of ongoing jobs and jobs waiting to be processed. When Log is selected, displays the job history. You can cancel jobs or check the error code displayed in the history when the job has failed.
4	Indicates the approximate ink levels.
5	Indicates the approximate service life of the maintenance box.
6	Displays any errors that have occurred in the printer. Select the error from the list to display the error message.

Related Information

➔ [“Error Code on the Status Menu” on page 250](#)

Viewing Animations

You can view animations of operating instructions such as loading paper or removing jammed paper on the LCD screen.

Tap  on the right of the LCD screen: Displays the help screen. Tap **How To** and select the items that you want to view.

Printer Basics

- ❑ Select **How To** at the bottom of the operation screen: Displays the context-sensitive animation.

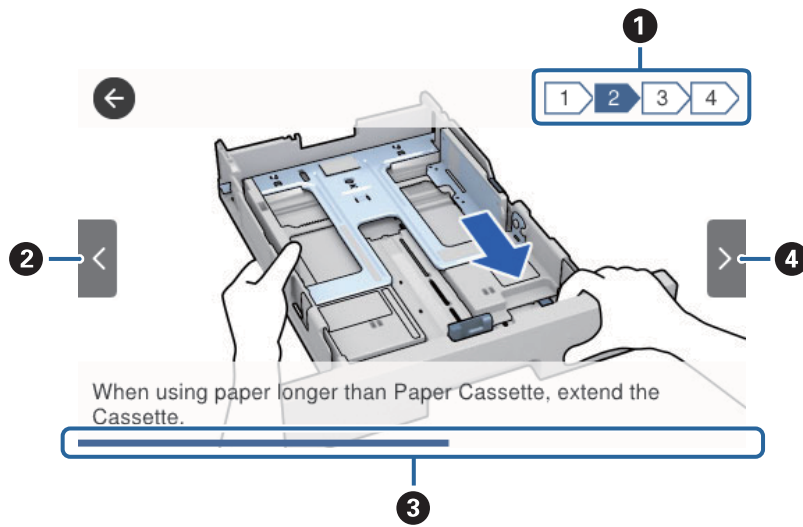

①	Indicates the total number of steps and the current step number. In the example above, it shows step 2 from 4 steps.
②	Returns to the previous step.
③	Indicates your progress through the current step. The animation repeats when the progress bar reaches the end.
④	Moves to next step.

Preparing the Printer

Loading Papers

Available Paper and Capacities

Note:

The paper size displayed differs depending on the driver.

Genuine Epson Paper

Epson recommends using genuine Epson paper to ensure high-quality printouts.

Note:

- Genuine Epson paper is not available when printing with the Epson universal printer driver.
- The availability of paper varies by location. For the latest information on paper available in your area, contact Epson support.
- When printing on genuine Epson paper at a user defined size, only **Standard** or **Normal** print quality settings are available. Although some printer drivers allow you to select a better print quality, the printouts are printed using **Standard** or **Normal**.

Paper suitable for printing documents

Media Name	Size	Loading Capacity (Sheets)			2-Sided Printing
		Paper Cassette 1	Paper Cassette 2 ~ Paper Cassette 3	Rear Paper Feed	
Epson Bright White Ink Jet Paper	A4	200	400	50	Auto, Manual*

- * Only use the rear paper feed to print 2-sided print jobs manually. You can load up to 30 sheets for paper with one side already printed.

Paper suitable for printing documents and photos

Media Name	Size	Loading Capacity (Sheets)			2-Sided Printing
		Paper Cassette 1	Paper Cassette 2 ~ Paper Cassette 3	Rear Paper Feed	
Epson Photo Quality Ink Jet Paper	A4	80	–	70	–

Preparing the Printer

Media Name	Size	Loading Capacity (Sheets)			2-Sided Printing
		Paper Cassette 1	Paper Cassette 2 ~ Paper Cassette 3	Rear Paper Feed	
Epson Matte Paper-Heavyweight	A4	50	–	20	–
Epson Double-Sided Matte Paper	A4	20	–	20	–

Paper suitable for printing photos

Media Name	Size	Loading Capacity (Sheets)			2-Sided Printing
		Paper Cassette 1	Paper Cassette 2 ~ Paper Cassette 3	Rear Paper Feed	
Epson Ultra Glossy Photo Paper	A4, 13×18 cm (5×7 in.), 10×15 cm (4×6 in.)	50	–	20	–
Epson Premium Glossy Photo Paper	A4, 13×18 cm (5×7 in.), 16:9 wide size (102×181 mm), 10×15 cm (4×6 in.)	50	–	20	–
Epson Premium Semigloss Photo Paper	A4, 10×15 cm (4×6 in.)	50	–	20	–
Epson Photo Paper Glossy	A4, 13×18 cm (5×7 in.), 10×15 cm (4×6 in.)	50	–	20	–

Related Information

➔ [“Part Names and Functions” on page 16](#)





Commercially Available Paper

Note:

Half letter, SP1 (210×270 mm), SP2 (210×149 mm), SP3 (100×170 mm), SP4 (130×182 mm), SP5 (192×132 mm) and 16K (195×270 mm) sizes are not available when printing with the PostScript printer driver.

Preparing the Printer

Plain papers

Media Name	Size	Loading Capacity (Sheets)			2-Sided Printing
		Paper Cassette 1	Paper Cassette 2 ~ Paper Cassette 3	Rear Paper Feed	
Plain paper, Copy paper Letterhead	Letter ^{*3} , A4, Executive ^{*3} , B5, A5, SP1 (210×270 mm), 16K (195×270 mm)	Up to the line indicated by the 		80	Auto, Manual ^{*1*} 2
Recycled paper Color paper Preprinted paper High quality plain paper	Legal, Indian-Legal, 8.5×13 in, Half letter ^{*3} , A6, B6, SP2 (210×149 mm), SP3 (100×170 mm), SP4 (130×182 mm)	Up to the line indicated by the 		80	Manual ^{*1*} 2
	SP5 (192×132 mm)	Up to the line indicated by the 	–	80	Manual ^{*1*} 2
	User Defined ^{*3} (mm) 89×127 to 215.9×148 89×148 to 100×355.6	Up to the line indicated by the 	–	80	Manual ^{*1*} 2
	User Defined ^{*3} (mm) 100×148 to 215.9×355.6	Up to the line indicated by the 		80	Auto ^{*5} , Manual ^{*1*} 2
	User Defined ^{*3} (mm) 64×127 to 215.9×355.6	–	–	80	Manual ^{*2}
	User Defined ^{*3} (mm) 64×355.6 to 215.9×6000	–	–	1	Manual

*1 Only use the rear paper feed to print 2-sided print jobs manually.

*2 You can load up to 30 sheets for paper with one side already printed.

*3 Only printing from computer is available.

*4 You can load up to 5 sheets for paper with one side already printed.

*5 For automatic 2-sided printing, 148×210 to 215.9×297 mm size paper is available.

Preparing the Printer

Thick papers

Media Name	Size	Loading Capacity (Sheets)			2-Sided Printing
		Paper Cassette 1	Paper Cassette 2 ~ Paper Cassette 3	Rear Paper Feed	
Thick paper (91 to 160 g/m ²)	Letter ^{*2} , A4, Executive ^{*2} , B5, A5, SP1 (210×270 mm), 16K (195×270 mm)	90	250	30	Auto, Manual ^{*1*} 3
	Legal, 8.5×13 in, Half letter ^{*2} , A6, B6, SP2 (210×149 mm), SP3 (100×170 mm), SP4 (130×182 mm)	90	250	30	Manual ^{*1*} 3
	SP5 (192×132 mm)	90	–	30	Manual ^{*1*} 3
	User Defined ^{*2} (mm) 89×127 to 215.9×148 89×148 to 100×355.6	90	–	30	Manual ^{*1*} 3
	User Defined ^{*2} (mm) 100×148 to 215.9×355.6	90	250	30	Auto ^{*4} , Manual ^{*1*} 3
	User Defined ^{*2} (mm) 64×127 to 215.9×355.6	–	–	30	Manual ^{*3}
	User Defined ^{*2} (mm) 64×355.6 to 215.9×1117.6	–	–	1	Manual
Thick paper (161 to 256 g/m ²)	Legal, 8.5×13 in, Letter ^{*2} , A4, Executive ^{*2} , B5, A5, Half letter ^{*2} , A6, B6, SP1 (210×270 mm), SP2 (210×149 mm), SP3 (100×170 mm), SP4 (130×182 mm), SP5 (192×132 mm), 16K (195×270 mm)	–	–	30	Manual ^{*3}
	User Defined ^{*2} (mm) 64×127 to 215.9×355.6	–	–	30	Manual ^{*3}
	User Defined ^{*2} (mm) 64×355.6 to 215.9×1117.6	–	–	1	Manual

*1 Only use the rear paper feed to print 2-sided print jobs manually.

*2 Only printing from computer is available.

*3 You can load up to 5 sheets for paper with one side already printed.

*4 For automatic 2-sided printing, 148×210 to 215.9×297 mm size paper is available.

Preparing the Printer

Envelopes

Media Name	Size	Loading Capacity (Envelopes)			2-Sided Printing
		Paper Cassette 1	Paper Cassette 2 ~ Paper Cassette 3	Rear Paper Feed	
Envelope	Envelope #10, Envelope DL, Envelope C6	10	–	10	–
	Envelope C4	–	–	1	–

Related Information

➔ [“Part Names and Functions” on page 16](#)

Paper Handling Precautions

- Read the instruction sheets supplied with the paper.
- To achieve high-quality printouts with genuine Epson paper, use the paper in the environment stated on the sheets supplied with the paper.
- Fan and align the edges of the paper before loading. Do not fan or curl photo paper. Doing so may damage the printable side.

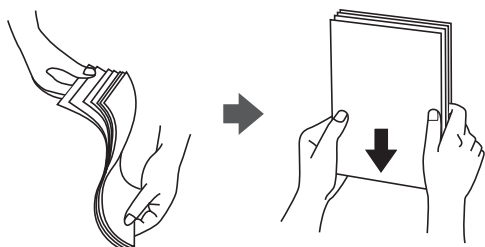

- If the paper is curled, flatten it or curl it slightly in the opposite direction before loading. Printing on curled paper may cause paper jams and smears on the printout.

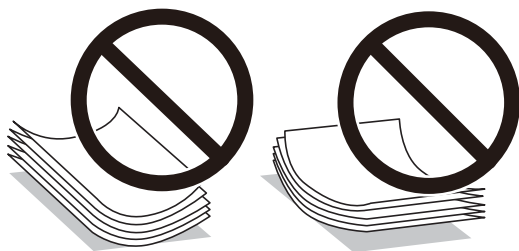

- Do not use paper that is wavy, torn, cut, folded, damp, too thick, too thin, or paper that has stickers stuck to it. Using these types of paper causes paper jams and smears on the printout.
- Make sure you are using long-grain paper. If you are not sure what type of paper you are using, check the paper packaging or contact the manufacturer to confirm the paper specifications.

Preparing the Printer

Related Information

➔ [“Printer Specifications” on page 295](#)

Loading Paper in the Paper Cassette

Note:

If the optional paper cassette unit is installed, do not pull out two paper cassettes at the same time.

1. Check that the printer is not operating, and then pull out the paper cassette.

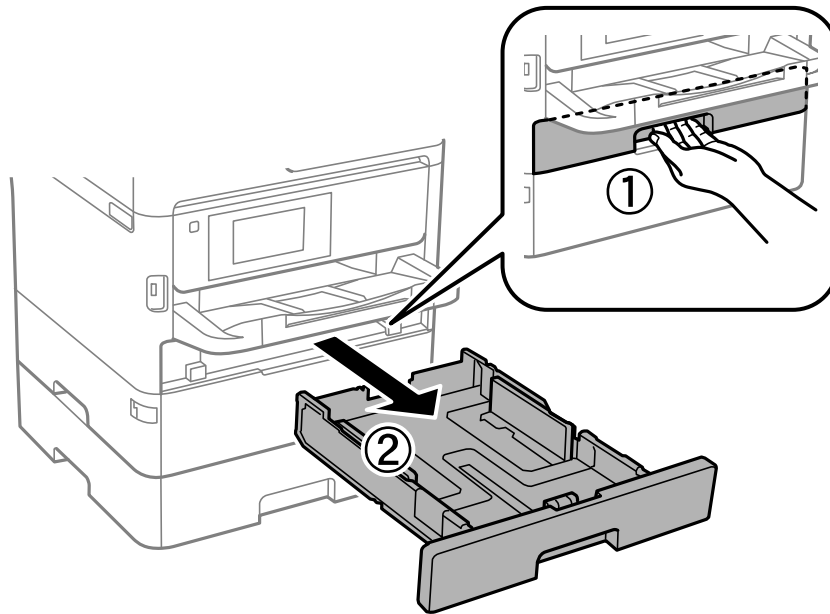

2. Slide the front edge guide to its maximum position, and then slide the side edge guides to adjust to the paper size you want to use.

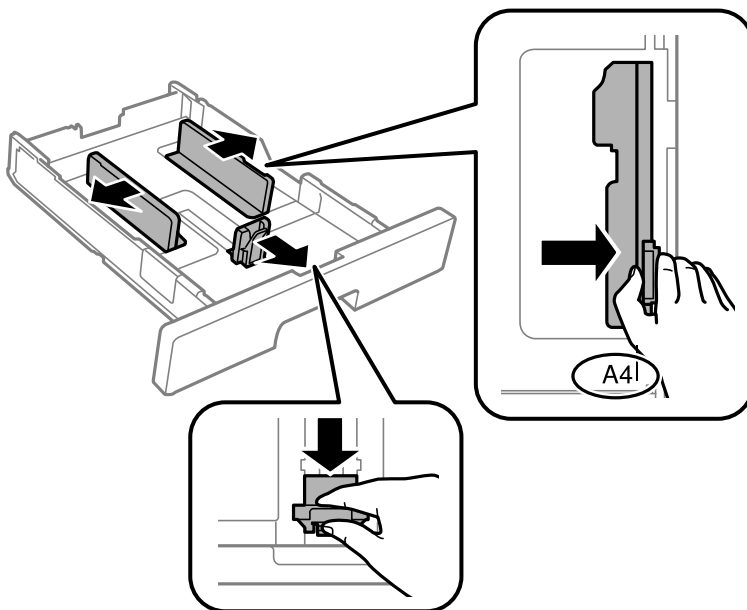

Preparing the Printer

Note:

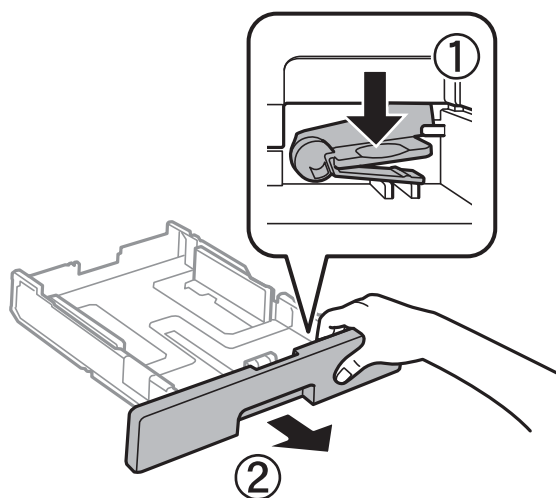

When using paper larger than A4 size, extend the paper cassette.

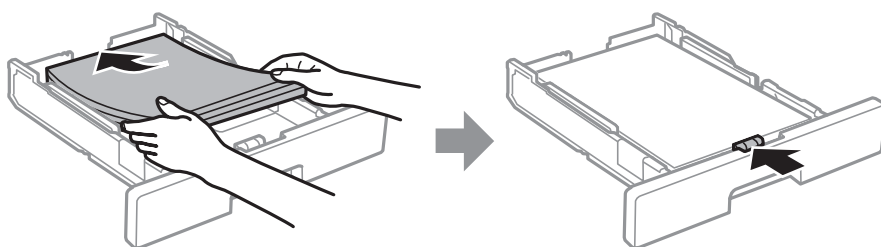

3. Load paper with the printable side facing down, and then slide the front edge guide to the edge of the paper.



! Important:

Do not load more than the maximum number of sheets specified for the paper. For plain paper, do not load above the line indicated by the  symbol inside the edge guide. For thick paper, do not load above the line indicated by the  symbol inside the edge guide.

4. Insert the paper cassette all the way.

Note:

When you extend the paper cassette, it sticks out of the printer a little bit.

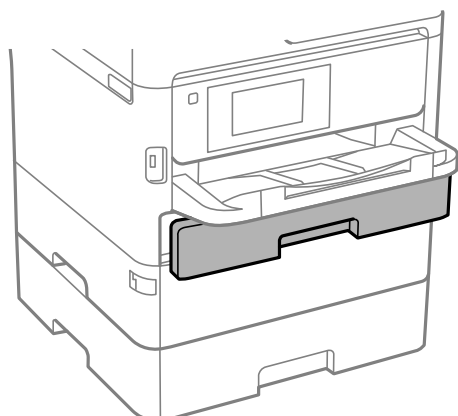

Preparing the Printer

5. On the control panel, set the size and type of the paper you loaded in the paper cassette.

Note:

You can also display the paper size and paper type settings screen by pressing the  button on the control panel.

6. Slide out the output tray when loading paper longer than A4 size.

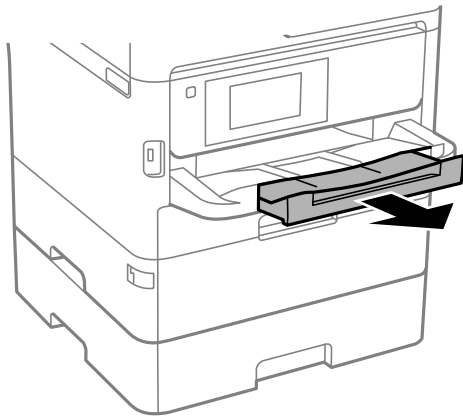

Related Information

- ➔ [“Paper Handling Precautions” on page 31](#)
- ➔ [“Available Paper and Capacities” on page 27](#)
- ➔ [“List of Paper Type” on page 38](#)
- ➔ [“Loading Envelopes and Precautions” on page 37](#)

Loading Paper in the Rear Paper Feed

1. Open the feeder guard and pull out the paper support.

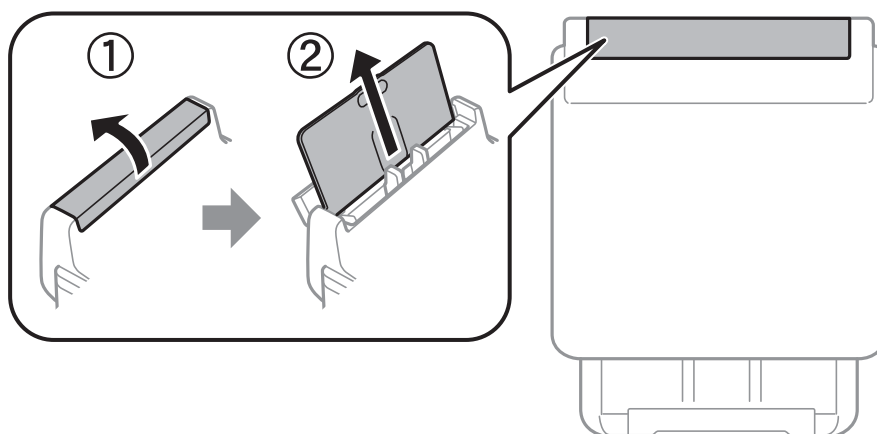

Preparing the Printer

- Slide the edge guides.

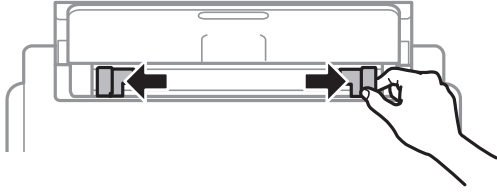

- Load paper at the center of the rear paper feed with the printable side facing up.

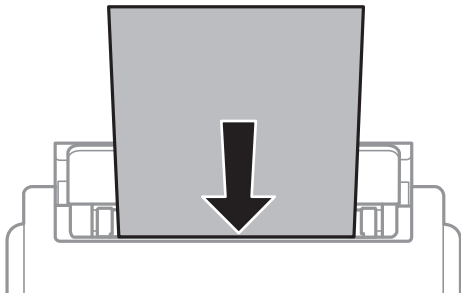

! **Important:**

- ❑ Do not load more than the maximum number of sheets specified for the paper. For plain paper, do not load above the line just under the triangle symbol inside the edge guide.
- ❑ Load paper short edge first. However, when you have set the long edge as the width of the user defined size, load paper long edge first.

Pre-punched paper

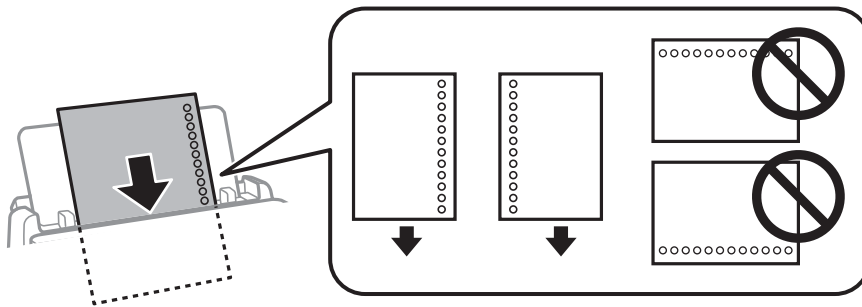

Note:

You can use pre-punched paper under the following conditions. Automatic 2-sided printing is not available for prepunched paper.

- ❑ Loading capacity: One sheet
- ❑ Available size: A4, B5, A5, A6, Letter, Legal
- ❑ Binding holes: Do not load paper with the binding holes at the top or the bottom. Adjust the print position of your file to avoid printing over the holes.
- ❑ Paper setting: Select **Letterhead** or **Preprinted** as the paper type setting.

Preparing the Printer

- Slide the edge guides to the edges of the paper.

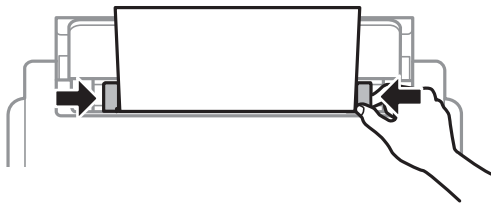

- On the control panel, set the size and type of the paper you loaded in the rear paper feed.

Note:

You can also display the paper size and paper type settings screen by pressing the  button on the control panel.

- Slide out the output tray when loading paper longer than A4 size.

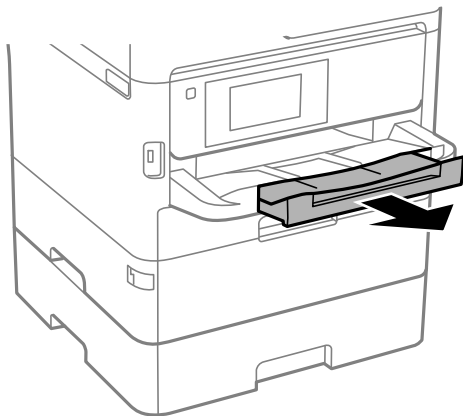

Note:

Return the remaining paper to its package. If you leave it in the printer, the paper may curl or the print quality may decline.

Related Information

- ➔ [“Paper Handling Precautions” on page 31](#)
- ➔ [“Available Paper and Capacities” on page 27](#)
- ➔ [“List of Paper Type” on page 38](#)
- ➔ [“Loading Envelopes and Precautions” on page 37](#)
- ➔ [“Loading Long Papers” on page 38](#)

Preparing the Printer

Loading Envelopes and Precautions

Load envelopes in the center of the rear paper feed short edge first with the flap facing down, and slide the edge guides to the edges of the envelopes.

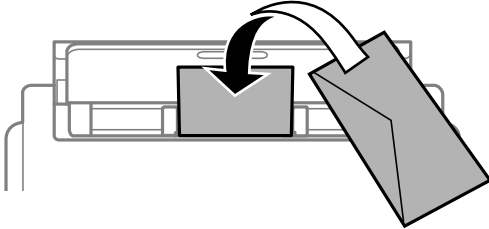

Load envelopes in the paper cassette with the flap facing up, and then slide the edge guides to the edges of the envelopes.

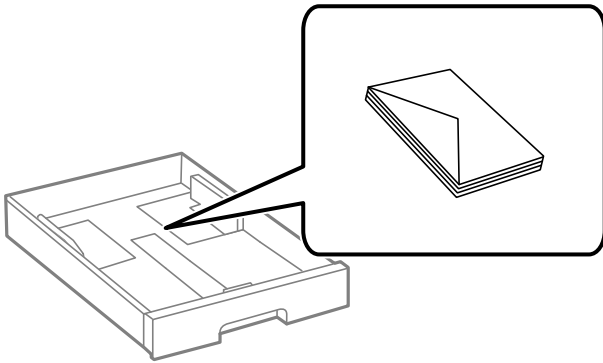

- ❑ Fan and align the edges of the envelopes before loading. When the stacked envelopes are puffed up with air, press them down to flatten them before loading.



- ❑ Do not use envelopes that are curled or folded. Using these envelopes causes paper jams and smears on the printout.
- ❑ Do not use envelopes with adhesive surfaces on the flaps or window envelopes.
- ❑ Avoid using envelopes that are too thin, as they may curl during printing.

Related Information

- ➔ [“Available Paper and Capacities” on page 27](#)
- ➔ [“Loading Paper in the Paper Cassette” on page 32](#)
- ➔ [“Loading Paper in the Rear Paper Feed” on page 34](#)

Preparing the Printer

Loading Long Papers

Only use the rear paper feed to load long paper. Before loading paper in the printer, cut the paper to the size you want to print. Select **User-Defined** as the paper size setting.

- Make sure the end of the paper is cut perpendicularly. A diagonal cut may cause paper feed problems.
- Long paper cannot be held in the output tray. Prepare a box and so on to make sure that paper does not fall on the floor.
- Do not touch paper that is being fed or ejected. It could injure your hand or cause print quality to decline.

Related Information

- ➔ [“Available Paper and Capacities” on page 27](#)
- ➔ [“Loading Paper in the Rear Paper Feed” on page 34](#)

List of Paper Type

To obtain optimum printing results, select the paper type that suits the paper.

Media Name	Media Type			
	Control Panel	Printer Driver	PostScript Printer Driver	Epson Universal Printer Driver
Epson Bright White Ink Jet Paper	Plain paper	Plain paper	Plain	Plain
Epson Ultra Glossy Photo Paper	Ultra Glossy	Epson Ultra Glossy	Epson Ultra Glossy	-
Epson Premium Glossy Photo Paper	Prem. Glossy	Epson Premium Glossy	Epson Premium Glossy	-
Epson Premium Semigloss Photo Paper	Prem. Semigloss	Epson Premium Semigloss	Epson Premium Semigloss	-
Epson Photo Paper Glossy	Glossy	Photo Paper Glossy	Photo Paper Glossy	-
Epson Matte Paper-Heavyweight Epson Photo Quality Ink Jet Paper	Matte	Epson Matte	Epson Matte	-
Thick paper (91 to 160 g/m ²)	Thick paper1	Thick-Paper1	Thick-Paper1	Thick-Paper1
Thick paper (161 to 256 g/m ²)	Thick paper2	Thick-Paper2	Thick-Paper2	Thick-Paper2

Placing Originals

Place originals on the scanner glass or the ADF.

You can scan multiple originals and both sides of the originals at the same time with the ADF.

Available Originals for the ADF

Available Paper Sizes	A6, A5, Half Letter*, B5, Executive, 16K, A4, Letter, Legal, 8.5×13 in*
Paper Type	Plain paper, High-quality plain paper, Recycled paper
Paper Thickness (Weight of Paper)	64 to 95 g/m ²
Loading Capacity	50 sheets or 5.5 mm

* Only single-sided scanning is supported.

Even when the original meets the specifications for media that can be placed in the ADF, it may not feed from the ADF or the scan quality may decline depending on the paper properties or quality.



Important:

Do not feed photographs or valuable original artwork into the ADF. Misfeeding may wrinkle or damage the original. Scan these documents on the scanner glass instead.

To prevent paper jams, avoid placing the following originals in the ADF. For these types, use the scanner glass.

- Originals that are torn, folded, wrinkled, deteriorated, or curled
- Originals with binder holes
- Originals held together with tape, staples, paper clips etc.
- Originals that have stickers or labels stuck to them
- Originals that are cut irregularly or not right angled
- Originals that are bound
- OHPs, thermal transfer paper, or carbon backs

Placing Originals on the ADF

1. Align the edges of the originals.

Preparing the Printer

2. Slide the ADF edge guide.

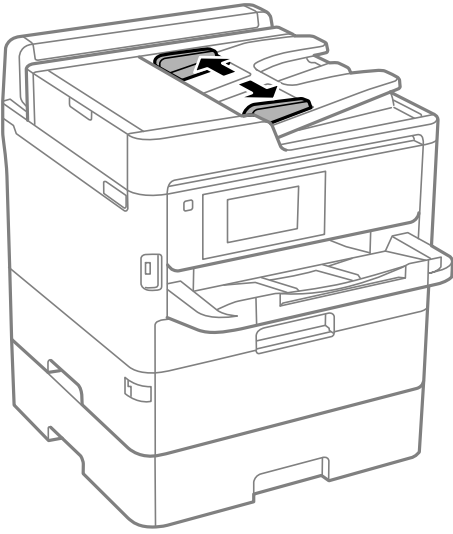

3. Place the originals in the center of the ADF, facing up.

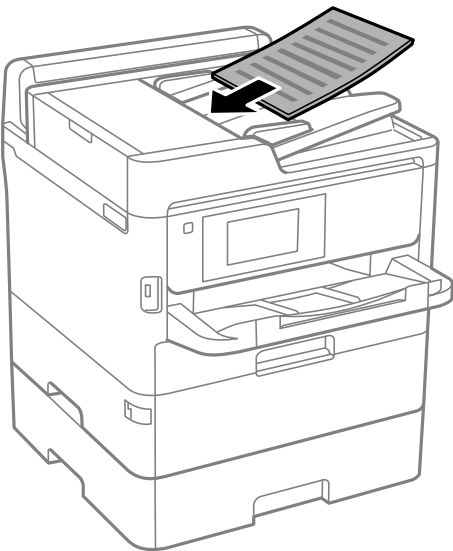

Preparing the Printer

! *Important:*

- ❑ Do not load originals above the line indicated by the triangle symbol on the ADF.

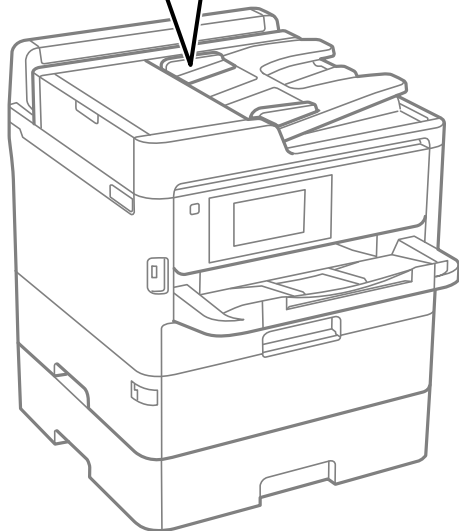
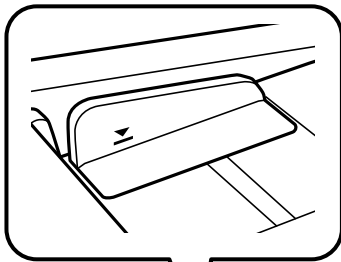

- ❑ Do not add originals while scanning.

4. Slide the ADF edge guide to the edge of the originals.

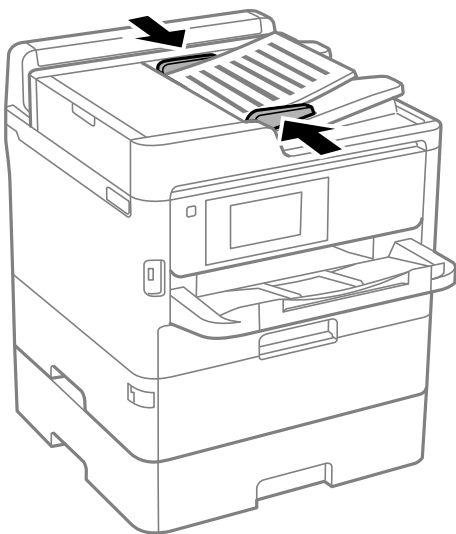

Related Information

- ➔ [“Available Originals for the ADF” on page 39](#)

Preparing the Printer

Placing Originals on the ADF for 2-up Copying

Place the originals in the direction shown in the illustration, and then select the orientation setting.

- Landscape originals: Select **Up Direction** on the control panel as described below.

Copy > Advanced > Orientation (Original) > Up Direction

Place the originals on the ADF in the direction of the arrow.



- Portrait originals: Select **Left Direction** on the control panel as described below.

Copy > Advanced > Orientation (Original) > Left Direction

Place the originals on the ADF in the direction of the arrow.



Placing Originals on the Scanner Glass



Caution:

Be careful not to trap your hand or fingers when opening or closing the document cover. Otherwise you may be injured.



Important:

When placing bulky originals such as books, prevent exterior light from shining directly onto the scanner glass.

Preparing the Printer

1. Open the document cover.

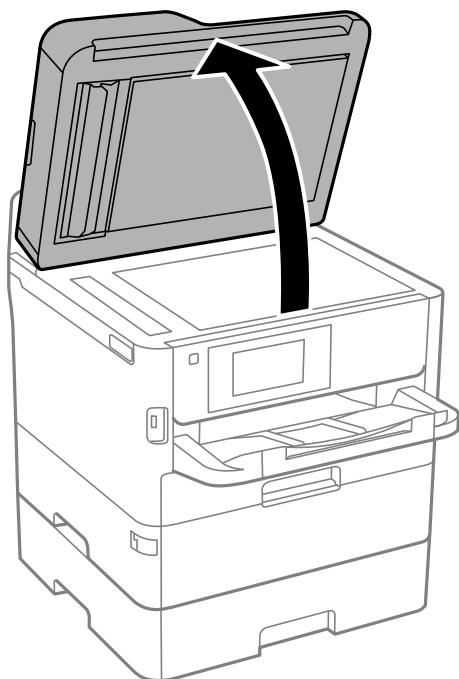

2. Remove any dust or stains on the scanner glass.
3. Place the original face-down and slide it to the corner mark.

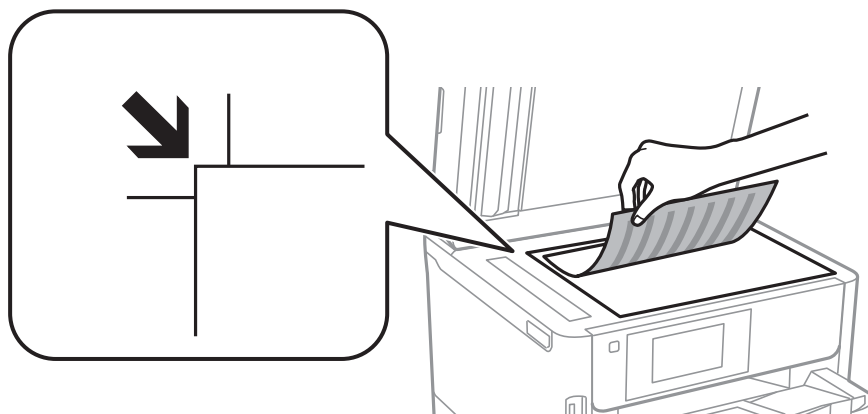

Note:

- ❑ A range of 1.5 mm from the top edge and left edge of the scanner glass is not scanned.
- ❑ When originals are placed in the ADF and on the scanner glass, priority is given to the originals in the ADF.

4. Close the cover gently.



Important:

Do not apply too much force to the scanner glass or the document cover. Otherwise, they may be damaged.

5. Remove the originals after scanning.

Note:

If you leave the originals on the scanner glass for a long time, they may stick to the surface of the glass.

Inserting an External USB Device

Inserting and Removing an External USB Device

1. Insert an external USB device into the printer.

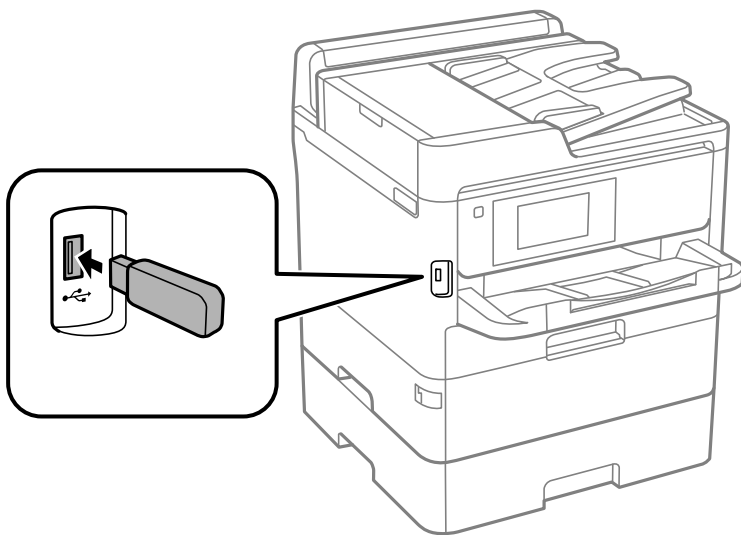

2. When you have finished using the external USB device, remove the device.

Related Information

- ➔ [“External USB Device Specifications” on page 299](#)
- ➔ [“Accessing an External USB Device From a Computer” on page 44](#)

Accessing an External USB Device From a Computer

You can write or read data on an external USB device such as a USB flash drive that has been inserted in the printer from a computer.

! Important:

When sharing an external device inserted in the printer between computers connected over USB and over a network, write access is only allowed to the computers that are connected by the method you selected on the printer. To write to the external USB device, select a connection method from the following menu on the printer's control panel.

Settings > General Settings > Printer Settings > Memory Device Interface > File Sharing.

Note:

It takes a while to recognize data from a computer if a large capacity external storage USB device, such as a device that is 2 TB, is connected.

Windows

Select an external USB device in **Computer** or **My Computer**. The data on the external USB device is displayed.

Preparing the Printer

Note:

If you connected the printer to the network without using the software disc or Web Installer, map a USB port as a network drive. Open **Run** and enter a printer name \\XXXXXX or a printer's IP address \\XXX.XXX.XXX.XXX to **Open**. Right-click a device icon displayed to assign the network. The network drive appears in **Computer** or **My Computer**.

Mac OS

Select a corresponding device icon. The data on the external USB device is displayed.

Note:

- To remove an external USB device, drag and drop the device icon to the trash icon. Otherwise, data in the shared drive may not be displayed correctly when another external USB device is inserted.
- To access an external storage device through the network, select **Go > Connect to Server** from the menu on the desktop. Enter a printer name `cifs://XXXXXX` or `smb://XXXXXX` (Where "xxxxx" is the printer name) in the **Server Address**, and then click **Connect**.

Using an Email Server

To use email features, such as scan or fax forwarding features, you need to configure the email server.

Configuring Mail Server

Check the following before configuring the email server.

- The printer is connected to the network.
- The email server information, such as the documents from your service provider that you used to setup the email on your computer.

Note:

If you use a free email service, such as Internet email, search the Internet to get the email server information you need.

1. Select **Settings** on the home screen.
2. Select **General Settings > Network Settings > Advanced**.
3. Select **Email Server > Server Settings**.

Preparing the Printer

4. Tap the authentication method of the email server you are using, and then the settings screen is displayed.



Important:

The following authentication methods are available.

- Off
- POP before SMTP
- SMTP-AUTH

Contact your internet service provider to confirm the authentication method of the email server.

The printer may not be able to communicate with an email server even if the authentication method is available since security may be enhanced (for example SSL communication is necessary). Visit the Epson support website for the latest information.

<http://www.epson.eu/Support> (Europe)

<http://support.epson.net/> (outside Europe)

5. Make the appropriate settings.

The necessary settings vary depending on the authentication method. Enter the information for the email server you are using.

6. Tap **Proceed**.

Note:

- If an error message is displayed, check if the email server settings are correct.
- When you cannot send an email even if the connection check succeeds, check the authentication method for the email server you are using.

Email Server Setting Items

Items	Explanations
Authenticated Account	If you select SMTP-AUTH or POP before SMTP as the Email Server Authentication Method , enter the user name (email address) registered to the email server within 255 characters or less.
Authenticated Password	If you select SMTP-AUTH or POP before SMTP as the Email Server Authentication Method , enter the password of the authenticated account within 20 characters or less.
Sender's Address	Specify the email address that the printer uses to send emails. You can specify the existing email address. To make it clear that the email is being sent from the printer, you can acquire an address specifically for the printer and enter it here.
SMTP Server Address	Enter the server address of the server that sends the email (SMTP server).
SMTP Server Port Number	Enter the port number of the server that sends the email (SMTP server).

Preparing the Printer

Items	Explanations
POP3 Server Address	If you select POP before SMTP as the Email Server Authentication Method , enter the server address of the server that receives the email (POP3 server).
POP3 Server Port Number	If you select POP before SMTP as the Email Server Authentication Method , enter the port number of the email server that receives the email (POP3 server).
Secure Connection	If you select SMTP-AUTH or Off as the Email Server Authentication Method , select the method of the secure connection.

Checking an Email Server Connection

1. Select **Settings** on the home screen.
2. Select **General Settings > Network Settings > Advanced**.
3. Select **Email Server > Connection Check** to check that the printer is connected to the email server.

Note:

- If an error message is displayed, check if the email server settings are correct.
- When you cannot send an email even if the connection check succeeds, check the authentication method for the email server you are using.

Messages Displayed During Connection Check

The following messages are displayed when performing a **Connection Check** to the email server. If an error occurs, check the message and the explanation to confirm the status.

Messages	Explanation
Connection test was successful.	This message appears when the connection with the server is successful.
SMTP server communication error. Check the following. - Network Settings	This message appears when <ul style="list-style-type: none"> <input type="checkbox"/> The printer is not connected to a network <input type="checkbox"/> SMTP server is down <input type="checkbox"/> Network connection is disconnected while communicating <input type="checkbox"/> Received incomplete data
POP3 server communication error. Check the following. - Network Settings	This message appears when <ul style="list-style-type: none"> <input type="checkbox"/> The printer is not connected to a network <input type="checkbox"/> POP3 server is down <input type="checkbox"/> Network connection is disconnected while communicating <input type="checkbox"/> Received incomplete data

Preparing the Printer

Messages	Explanation
An error occurred while connecting to SMTP server. Check the followings. - SMTP Server Address - DNS Server	This message appears when <input type="checkbox"/> Connecting to a DNS server failed <input type="checkbox"/> Name resolution for an SMTP server failed
An error occurred while connecting to POP3 server. Check the followings. - POP3 Server Address - DNS Server	This message appears when <input type="checkbox"/> Connecting to a DNS server failed <input type="checkbox"/> Name resolution for an POP3 server failed
SMTP server authentication error. Check the followings. - Authentication Method - Authenticated Account - Authenticated Password	This message appears when SMTP server authentication failed.
POP3 server authentication error. Check the followings. - Authentication Method - Authenticated Account - Authenticated Password	This message appears when POP3 server authentication failed.
Unsupported communication method. Check the followings. - SMTP Server Address - SMTP Server Port Number	This message appears when you try to communicate with unsupported protocols.
Connection to SMTP server failed. Change Secure Connection to None.	This message appears when an SMTP mismatch occurs between a server and a client, or when the server does not support SMTP secure connection (SSL connection).
Connection to SMTP server failed. Change Secure Connection to SSL/TLS.	This message appears when an SMTP mismatch occurs between a server and a client, or when the server requests to use an SSL/TLS connection for an SMTP secure connection.
Connection to SMTP server failed. Change Secure Connection to STARTTLS.	This message appears when an SMTP mismatch occurs between a server and a client, or when the server requests to use an STARTTLS connection for an SMTP secure connection.
The connection is untrusted. Check the following. - Date and Time	This message appears when the printer's date and time setting is incorrect or the certificate has expired.
The connection is untrusted. Check the following. - CA Certificate	This message appears when the printer does not have a root certificate corresponding to the server or a CA Certificate has not been imported.
The connection is not secured.	This message appears when the obtained certificate is damaged.
SMTP server authentication failed. Change Authentication Method to SMTP-AUTH.	This message appears when an authentication method mismatch occurs between a server and a client. The server supports SMTP AUTH.
SMTP server authentication failed. Change Authentication Method to POP before SMTP.	This message appears when an authentication method mismatch occurs between a server and a client. The server does not support SMTP AUTH.
Sender's Email Address is incorrect. Change to the email address for your email service.	This message appears when the specified sender's Email address is wrong.
Cannot access the printer until processing is complete.	This message appears when the printer is busy.

Managing Contacts

Registering a contacts list allows you to easily enter destinations. You can register up to 2000 entries, and you can use the contacts list when you enter a fax number, enter a destination for attaching a scanned image to an email, and saving a scanned image to a network folder.

You can also use contacts in the LDAP server.

Starting from Importing Contacts from Another Epson Printer

If you have a printer that allows you to backup contacts and is compatible with this printer, you can register contacts easily by importing the backup file.

Note:

For instructions on how to back up the printer contact,s, see the manual provided with the printer.

Follow the steps below to import the contacts to this printer.

1. Access Web Config, select **Device Management > Export and Import Setting Value > Import**.
2. Select the backup file you created in **File**, enter the password, and then click **Next**.
3. Select the **Contacts** checkbox, and then click **Next**.

Registering or Editing Contacts

Note:

Before registering contacts, make sure you have also configured the email server settings to use the email address.

1. Select **Settings** on the home screen.
2. Select **Contacts Manager**, and then select **Register/Delete**.
3. Do one of the following.
 - To register a new contact, select **Add Entry**, and then select **Add Contact**.
 - To edit a contact, select the target contact, and then select **Edit**.
 - To delete a contact, select the target contact, select **Delete**, and then select **Yes**. You do not have to perform following procedures.

Note:

*You can register an address that is registered in the LDAP server in the local contacts list of the printer. Display an entry, and then select **Register to Contacts**.*

4. When registering a new contact, select the type of contact you want to register. Skip this procedure when you want to edit or delete a contact.
 - Fax: Register a contact (fax number) to send a fax.
 - Email: Register an email address to send a scanned image or to forward the received fax.
 - Network Folder/FTP: Register a network folder to save a scanned image or to forward the received fax.

Preparing the Printer

5. Enter the information of the address to register. Enter the required items, and then make other settings if necessary.

Note:

*When entering a fax number, enter an external access code at the beginning of the fax number if your phone system is PBX and you need the access code to get an outside line. If the access code has been set in the **Line Type** setting, enter a hash (#) instead of the actual access code. To add a pause (pause for three seconds) during dialing, enter a hyphen (-).*

6. Select **OK**.

Registering or Editing Grouped Contacts

Adding contacts to a group allows you to send a fax or send a scanned image by an email to multiple destinations at the same time.

1. Select **Settings** on the home screen.
2. Select **Contacts Manager**, and then select **Register/Delete**.
3. Do one of the following.
 - To register a new group, select **Add Entry**, and then select **Add Group**.
 - To edit a group, select the target group, and then select **Edit**.
 - To delete a group, select the target group, select **Delete**, and then select **Yes**. You do not have to perform following procedures.
4. When registering a new group, select the type of group you want to register. Skip this procedure when you want to edit a group.
 - Fax: Register a contact (fax number) to send a fax.
 - Email: Register an email address to send a scanned image or to forward the received fax.
5. Enter or edit the **Group Name (Required)** for the group.
6. Select **Contact(s) Added to the Group (Required)**.
7. Select the contacts that you want to register in the group.

Note:

 - You can register up to 200 contacts.
 - To deselect a contact, tap it again.
8. Select **Close**.
9. Make the other necessary settings.
 - Registry Number: Set the number for a group.
 - Index Word: Set index word for the group.
 - Assign to Frequent Use: Register as a frequently used group. The group is displayed at the top of the screen where you specify the address.
10. Select **OK**.

Preparing the Printer

Registering Frequently Used Contacts

When you register frequently used contacts, the contacts are displayed at the top of the screen where you specify the address.

1. Select **Settings** on the home screen.
2. Select **Contacts Manager**, and then select **Frequent**.
3. Select the type of contact you want to register.
4. Select **Edit**.

Note:

*To edit the order of the contacts, select **Sort**.*

5. Select frequently used contacts that you want to register, and then select **OK**.

Note:

To deselect a contact, tap it again.

You can search for addresses from the contacts list. Enter the search keyword into the box on the top of the screen.

6. Select **Close**.

Register Contacts on a Computer

Using Web Config, you can create a contact list on your computer and import it to the printer.

See the *Administrator's Guide* for details.

Backing up Contacts using a Computer

Contacts data may be lost due to a printer malfunction. We recommend that you make a backup of the data whenever you update the data. Epson shall not be responsible for the loss of any data, for backing up or recovering data and/or settings even during a warranty period.

Using Web Config, you can back up the contact data stored in the printer to the computer.

1. Access Web Config, and then select the **Device Management** tab > **Export and Import Setting Value** > **Export**.
2. Select one of the **Contacts** checkboxes.
For example, if you select **Contacts** under the **Scan/Copy** category, the same checkbox under the Fax category is also selected.
3. Enter a password to encrypt the exported file.
You need the password to import the file. Leave this blank if you do not want to encrypt the file.
4. Click **Export**.

Setting a Shared Folder

You can save the scanned image and the results of faxing to a specified folder on a network. You can specify a shared folder on the computer, created using SMB protocols, or a folder on an FTP sever.

Note:

- ❑ *The printer and the computer should be connected to the same network. If your organization has a printer administrator, contact the administrator for the network settings.*
- ❑ *If you want to save scanned images to an FTP server, contact the FTP server administrator to confirm the server information.*
- ❑ *The method to set the shared folder varies depending on the operating system and your environment. In this manual, the examples used are for Windows 10/Windows 8.1/Windows 8/Windows 7. See the documentation of your computer for detailed information about setting a shared folder on your computer.*

Checking the Computer Name

Check the computer name on which you want to create the shared folder.

Use alphanumerical characters for the computer name. If other characters are used, you cannot find the computer from the printer.

1. Open the system window for the computer.
 - ❑ Windows 10/Windows 8.1/Windows 8:
Press the X key while holding down the Windows key on the keyboard, and then select **System** from the list.
 - ❑ Windows 7:
Click the start button, right-click **Computer**, and then select **Property**.
2. Check **Computer Name** on the **System** window.

Note:

*Use alphanumerical characters for the computer name. If the computer name uses any other characters, change the name. When there is a printer administrator in your organization, contact the administrator for changing the **Computer Name**.*

Enabling the Sharing Setting

Set the folder you want to share on the computer where the shared folder will be created.

The following procedure is for when a password is set on the computer.

1. Open the **Control Panel**.
 - ❑ Windows 10:
Click on the start button, and then select **Windows System > Control Panel**.
 - ❑ Windows 8.1/Windows 8:
Select **Desktop > Settings > Control Panel**.
 - ❑ Windows 7:
Click the start button and select **Control Panel**.

Preparing the Printer

2. On the **Control Panel** window, click **Network and Internet**.
3. On the **Network and Internet** window, click **Network and Sharing Center**.
4. On the **Network and Sharing Center** window, click **Change advanced sharing settings**.
5. On the **Advanced sharing settings** window, select **Turn on file and printer sharing** on the **File and printer sharing**. Click **Save changes** and close the window.
If it is already selected, click **Cancel** and close the window.
6. On the **Network and Sharing Center** window, click × at the top-right on the window to close the window.

Creating a Shared Folder

Create a folder on the computer, and then set the folder to be shared on the network.

Use the following procedure when creating the "scan" folder on the desktop of a computer that has a password set.

The user who logs in to the computer and who has administrator authority can access the desktop folder and the document folder that are under the User folder.

1. Start the explorer.
2. Create the folder on the desktop, and then name it "scan".
The folder name should be 12 characters or less. If the name exceeds 12 characters, the printer may not be able to access the folder depending on your environment.
3. Right-click the created folder, and then select **Properties**.
Grant change access permission to share access permissions for the user account. This is applied when the user accesses the folder over a network.
4. Select the **Sharing** tab on the **Properties** window.
5. Click **Advanced Sharing** on the **Sharing** tab.
6. On the **Advanced Sharing** window, enable **Share this folder**, and then click **Permissions**.
7. On the **Share Permissions** tab, select **Everyone** from **Group or user names**, allow the **Change**, and then click **OK**.
8. Click **OK**.
9. Select **Security** tab.
10. Check the group or the user in the **Group or user names**.
The group or the user that is displayed here can access the shared folder.
In this case, the user who logs in to this computer and the Administrator can access the shared folder.

Preparing the Printer

11. Select **Sharing** tab. The network path for the shared folder is displayed. This path is necessary when registering contacts on the printer, make sure you write it down or copy and save it.
12. Click **OK** or **Close** to close the window.

Note:

*The folder icon does not change after sharing. **Shared** is displayed as the **State** on the folders window.*

Registering the Shared Folder in Contacts

By registering a shared folder path on the printer's control panel, you can specify the folder path by selecting from contacts.

You need the following information to register to contacts.

- User name and password to log on to the computer
- Network path for the shared folder
- IP address of the printer or printer name (only when registering from the computer)

Registering from the Control Panel of the Printer

You can register contacts from the printer's control panel.

1. Select **Settings** from the home screen.
2. Select **Contacts Manager**, and then select **Register/Delete**.
3. Select **Add Entry**, and then select **Add Contact**.
4. Select **Network Folder/FTP**.
5. Make the necessary information.
 - Registry Number: Set a registration number for the address.
 - Name: Enter a Name to display in the contacts list.
 - Index Word: Enter the index word used when searching for the contacts list.
 - Communication Mode: Select SMB.
 - Location (Required): Enter the network path of the shared folder.
 - User Name: Enter a user name to log on to the computer. (only when password is set on the computer)
 - Password: Enter a password corresponding to the user name.
 - Assign to Frequent Use: Set the address as a frequently used address. The group will be displayed on the top screen when specifying the address.
6. Select **OK**. This completes registering a contact to the contacts list.

Registering Your Favorite Settings as a Preset

You can register frequently used copy, fax, and scan settings as presets. You can register up to 50 entries. If you cannot edit the presets, they may have been locked by the administrator. Contact your printer administrator for assistance.

To register a preset, select **Presets** from the home screen, select **Add New**, and then select the feature for which you want to register a preset. Make the necessary settings, select , and then enter a name for the preset.

To load a registered preset, select the preset from the list.

You can also register the current address and settings to select  on the screen of each feature.

To change the registered settings, change the settings on the screen for each feature and select . Select **Save as Preset**, and then select the target that you want to overwrite.

Menu Options for Presets

Select  on the registered preset to display the details of the registered settings. You can change the registered name by selecting the name on the details screen.



Delete the registered preset.

Add /Remove:

Add or clear the registered preset to the home screen as a short-cut icon.

Use This Setting:

Load the registered preset.

Menu Options for Settings

Select **Settings** on the home screen of the printer to make various settings.

Menu Options for General Settings

Select the menus on the control panel as described below.

Settings > General Settings

Basic Settings

Select the menus on the control panel as described below.

Settings > General Settings > Basic Settings

You cannot change settings that have been locked by your administrator.

Preparing the Printer

LCD Brightness:

Adjust the brightness of the LCD screen.

Sound:

Adjust the volume and select the type of the sound.

Sleep Timer:

Adjust the time period to enter a sleep mode (energy saving mode) when the printer has not performed any operations. The LCD screen turns black when the setting time passes.

Power Off Timer:

Your product may have this feature or the **Power Off Settings** feature depending on the location of purchase.

Select this setting to turn the printer off automatically when it is not used for a specified period of time. You can adjust the time before power management is applied. Any increase will affect the product's energy efficiency. Please consider the environment before making any change.

Power Off Settings:

Your product may have this feature or the **Power Off Timer** feature depending on the location of purchase.

Power Off If Inactive

Select this setting to turn the printer off automatically if it is not used for a specified period of time. Any increase will affect the product's energy efficiency. Please consider the environment before making any change.

Power Off If Disconnected

Select this setting to turn the printer off after 30 minutes when all ports including the LINE port are disconnected. This feature may not be available depending on your region.

Date/Time Settings:

Date/Time

Enter the current date and time.

Daylight Saving Time

Select the summer time setting that applies to your area.

Time Difference

Enter the time difference between your local time and UTC (Coordinated Universal Time).

Country/Region:

Select the country or region in which you are using your printer. If you change the country or region, your fax settings return to their defaults and you must select them again.

Language:

Select the language used on the LCD screen.

Start-up Screen:

Specify the initial menu displayed on the LCD screen when the printer turns on and **Operation Time Out** is enable.

Preparing the Printer

Edit Home:

Change the layout of the icons on the LCD screen. You can also add, remove, and move icons.

Wall Paper:

Change the background color of the LCD screen.

Operation Time Out:

Select **On** to return to the initial screen when no operations have been performed for the specified time. When user restrictions have been applied and no operations are performed for the specified time, you are logged out and returned to the initial screen.

Keyboard:

Change the layout of the keyboard on the LCD screen.

Default Screen(Job/Status):

Select the default information you want to display when you press the  button.

Related Information

➔ [“Saving Power” on page 68](#)

➔ [“Entering Characters” on page 24](#)

Printer Settings

Select the menus on the control panel as described below.

Settings > General Settings > Printer Settings

You cannot change settings that have been locked by your administrator.

Paper Source Settings:

Paper Setting:

Select the paper size and paper type you loaded in the paper sources.

Rear Paper Feed Priority:

Select **On** to give printing priority to paper loaded in the rear paper feed.

A4/Letter Auto Switching:

Select **On** to feed paper from the paper source set as A4 size when there is no paper source set as Letter, or feed from the paper source set as Letter size when there is no paper source set as A4.

Auto Select Settings:

Select **On** for any of following settings to automatically print on paper from any sources containing paper that matches your paper settings.

Copy

Fax

Preparing the Printer

- Other

Error Notice:

Select **On** to display an error message when the selected paper size or type does not match the loaded paper.

Paper Setup Auto Display:

Select **On** to display the **Paper Setting** screen when loading paper in the paper source. If you disable this feature, you cannot print from an iPhone or iPad using AirPrint.

Printing Language:

Select the printing language for the USB interface or the network interface.

Universal Print Settings:

These print settings are applied when you print by an external device without using the printer driver.

Top Offset:

Adjust the top margin of the paper.

Left Offset:

Adjust the left margin of the paper.

Top Offset in Back:

Adjust the top margin for the back of the page when performing 2-sided printing.

Left Offset in Back:

Adjust the left margin for the back of the page when performing 2-sided printing.

Check Paper Width:

Select **On** to check the paper width before printing. This prevents printing beyond the edges of the paper when the paper size setting is incorrect, but this may lower the print speed.

Skip Blank Page:

Skips blank pages in the print data automatically.

PDL Print Configuration:

Select the PDL Print Configuration options you want to use for PCL or PostScript printing.

Common Settings:

- Paper Size

Select the default paper size for PCL or PostScript printing.

- Paper Type

Select the default paper type for PCL or PostScript printing.

- Orientation

Select the default orientation for PCL or PostScript printing.

- Quality

Select the print quality for PCL or PostScript printing.

Preparing the Printer

- Ink Save Mode
Select **On** to save ink by reducing the print density.
- Print Order
Last Page on Top
Starts printing from the first page of a file.
First Page on Top
Starts printing from the last page of a file.
- Number of Copies
Set the number of copies to print.
- Binding Margin
Select the binding position.
- Auto Paper Ejection
Select **On** to eject paper automatically when printing is stopped during a print job.
- 2-Sided Printing
Select **On** to perform 2-sided printing.

PCL Menu:

- Font Source
Resident
Select to use a font preinstalled on the printer.
Download
Select to use a font you have downloaded.
- Font Number
Select the default font number for the default font source. The available number varies depending on the settings you made.
- Pitch
Set the default font pitch if the font is scalable and of fixed-pitch. You can select from 0.44 to 99.99 cpi (characters per inch), in 0.01 increments.
This item may not appear depending on the font source or font number settings.
- Height
Set the default font height if the font is scalable and proportional. You can select from 4.00 to 999.75 points, in 0.25 increments.
This item may not appear depending on the font source or font number settings.
- Symbol Set
Select the default symbol set. If the font that you selected in the font source and the font number setting is not available in the new symbol set setting, the font source and the font number settings are automatically replaced with the default value, IBM-US.
- Form
Set the number of lines for the selected paper size and orientation. This also causes a line spacing (VMI) change, and the new VMI value is stored in the printer. This means that later changes in the page size or orientation settings cause changes in the Form value based on the stored VMI.

Preparing the Printer

CR Function

Select the line feed command when printing with a driver from a specific operating system.

LF Function

Select the line feed command when printing with a driver from a specific operating system.

Paper Source Assign

Set the assignment for the paper source select command. When **4** is selected, the commands are set as compatible with the HP LaserJet 4. When **4K** is selected, the commands are set as compatible with the HP LaserJet 4000, 5000, and 8000. When **5S** is selected, the commands are set as compatible with the HP LaserJet 5S.

PS3 Menu:

Error Sheet

Select **On** to print a sheet showing the status when an error occurs during PostScript or PDF printing.

Coloration

Select the color mode for PostScript printing.

Binary

Select **On** when printing data that contains binary images. The application may send the binary data even if the printer driver setting is set to ASCII, but you can print the data when this feature is enabled.

PDF Page Size

Select the paper size when printing a PDF file. If **Auto** is selected, the paper size is determined based on the size of the first page.

Auto Error Solver:

Select an action to perform when a 2-sided printing error or a memory full error occurs.

On

Displays a warning and prints in single-sided mode when a 2-sided printing error occurs, or prints only what the printer could process when a memory full error occurs.

Off

Displays an error message and cancels printing.

Memory Device Interface:

Memory Device:

Select **Enable** to allow the printer to access an inserted memory device. If **Disable** is selected, you cannot save data to the memory device with the printer. This prevents confidential documents from being removed illegally.

File Sharing:

Select whether to give write access to the memory device from a USB-connected computer or a network-connected computer.

Thick Paper:

Select **On** to prevent ink from smearing on your printouts, however, this may lower the print speed.

Preparing the Printer

Quiet Mode:

Select **On** to reduce noise during printing, however, this may lower the print speed. Depending on the paper type and print quality settings you selected, there may be no difference in the printer's noise level.

Ink Drying Time:

Select the ink drying time you want to use when performing 2-sided printing. The printer prints the other side after printing one side. If your printout is smeared, increase the time setting.

Bidirectional:

Select **On** to change the print direction; Prints while the print head moves to the left and to the right. If vertical or horizontal ruled lines on your printout look blurred or misaligned, disabling this feature may solve the problem; however, doing so may reduce print speed.

PC Connection via USB:

Select **Enable** to allow a computer to access the printer when connected by USB. When **Disable** is selected, printing and scanning that is not sent over a network connection is restricted.

USB I/F Timeout Setting:

Specify the length of time in seconds that must elapse before ending USB communication with a computer after the printer receives a print job from a PostScript printer driver or PCL printer driver. If the job ending is not clearly defined from a PostScript printer driver or PCL printer driver, it can cause endless USB communication. When this occurs, the printer ends communication after the specified time has elapsed. Enter 0 (zero) if you do not want to end communication.

Related Information

- ➔ [“Loading Papers” on page 27](#)
- ➔ [“Printing JPEG Files from a Memory Device” on page 158](#)
- ➔ [“Printing PDF or TIFF Files from a Memory Device” on page 159](#)

Network Settings

Select the menus on the control panel as described below.

Settings > General Settings > Network Settings

You cannot change settings that have been locked by your administrator.

Wi-Fi Setup:

Set up or change wireless network settings. Choose the connection method from the following and then follow the instructions on the LCD panel.

- Router
- Wi-Fi Direct

Wired LAN Setup:

Set up or change a network connection that uses a LAN cable and router. When this is being used, Wi-Fi connections are disabled.

Preparing the Printer

Network Status:

Displays or prints the current network settings.

- Wired LAN/Wi-Fi Status
- Wi-Fi Direct Status
- Email Server Status
- Print Status Sheet

Connection Check:

Checks the current network connection and prints a report. If there are any problems with the connection, see the report to solve the problem.

Advanced:

Make the following detailed settings.

- Device Name
- TCP/IP
- Proxy Server
- Email Server
- IPv6 Address
- MS Network Sharing
- Link Speed & Duplex
- Redirect HTTP to HTTPS
- Disable IPsec/IP Filtering
- Disable IEEE802.1X
- iBeacon Transmission

Web Service Settings

Select the menus on the control panel as described below.

Settings > General Settings > Web Service Settings

You cannot change settings that have been locked by your administrator.

Epson Connect Services:

Displays whether the printer is registered and connected to Epson Connect.

You can register to the service by selecting **Register** and follow the instructions.

When you have registered, you can change the following settings.

- Suspend/Resume
- Unregister

For details, see the following web site.

<https://www.epsonconnect.com/>

Preparing the Printer

<http://www.epsonconnect.eu> (Europe only)

Google Cloud Print Services:

Displays whether the printer is registered and connected to Google Cloud Print services.

When you have registered, you can change the following settings.

- Enable/Disable
- Unregister

For details on registering to Google Cloud Print services, see the following web site.

<https://www.epsonconnect.com/>

<http://www.epsonconnect.eu> (Europe only)

Related Information

➔ [“Printing Using a Network Service” on page 247](#)

Fax Settings

Select the menu on the control panel as described below.

Settings > General Settings > Fax Settings

See Related Information below.

Related Information

➔ [“Menu Options for Faxing” on page 206](#)

Scan Settings

Select the menu on the control panel as described below.

Settings > General Settings > Scan Settings

See Related Information below.

Related Information

➔ [“Scanning to a Network Folder or FTP Server” on page 171](#)

➔ [“Scanning to a Memory Device” on page 180](#)

➔ [“Scanning to the Cloud” on page 182](#)

Menu Options for System Administration

By using this menu, you can maintain the product as a system administrator. It also allows you to restrict product features for individual users to suite your work or office style.

Select the menus on the control panel as described below.

Preparing the Printer

Settings > General Settings > System Administration

Contacts Manager:

You can make the following settings for contacts.

Register/Delete:

Register and/or delete contacts for the Fax, Scan to Email, and Scan to Network Folder/FTP menus.

Frequent:

Register frequently used contacts to access them quickly. You can also change the order of the list.

Print Contacts:

Print your contact list.

View Options:

Change the way the contact list is displayed.

Search Options:

Change the method for searching contacts.

Clear Internal Memory Data:

This item is displayed on PCL or PostScript compatible printer.

Delete the printer's internal memory data, such as a downloaded font and macro for PCL printing or a job of password printing.

Security Settings:

You can make the following security settings.

Restrictions:

Permit to change the settings of the following items when panel lock is enabled.

- Job log access
- Access to Register/Delete Contacts
- Fax Recent access
- Fax Transmission Log access
- Access to Fax Report
- Access to Print Save History of Scan to Network Folder/FTP
- Access to Recent of Scan to Email
- Access to Show Sent History of Scan to Email
- Access to Print Sent History of Scan to Email
- Access to Language
- Access to Thick Paper
- Access to Quiet Mode

Preparing the Printer

- Protection of Personal Data

Access Control:

Select **On** to restrict product features. This requires users to log into the product control panel with their user name and password before they can use control panel features. In **Accept Unknown User Jobs**, you can select whether or not to allow jobs that do not have the necessary authentication information.

Admin Settings:

- Admin Password
Set, change, and clear an administrator password.
- Lock Setting
Select whether or not to lock the control panel using the password registered in **Admin Password**.

Restore Default Settings:

Reset the settings in the following menus to their defaults.

- Network Settings
- Copy Settings
- Scan Settings
- Fax Settings
- Clear All Data and Settings

Firmware Update:

You can get firmware information such as your current version and information on available updates.

Update:

Check if the latest version of the firmware has been uploaded to the network server. If an update is available, you can select whether or not to start updating.

Notification:

Select **On** to receive a notification if a firmware update is available.

Menu Options for Print Counter

Select the menus on the control panel as described below.

Settings > Print Counter

Displays the total number of prints, B&W prints, and color prints including items such as the status sheet from the time you purchased the printer. Select **Print Sheet** when you want to print the result.



Menu Options for Supply Status

Select the menu on the control panel as described below.

Settings > Supply Status

Preparing the Printer

Displays the approximate level of the ink and service life of the maintenance box.

When  is displayed, ink is running low or the maintenance box is nearly full. When  is displayed, you need to replace the item as ink is expended or the maintenance box is full.

Menu Options for Maintenance

Select the menus on the control panel as described below.

Settings > Maintenance

Print Quality Adjustment:

Select this feature if there are any problems with your printouts. You can check for clogged nozzles and clean the print head if necessary, and then adjust some parameters to improve print quality.

Print Head Nozzle Check:

Select this feature to check if the print head nozzles are clogged. The printer prints a nozzle check pattern.

Print Head Cleaning:

Select this feature to clean clogged nozzles in the print head.

Ruled Line Alignment:

Select this feature to align vertical lines.

Paper Guide Cleaning:

Select this feature if there are ink stains on the internal rollers. The printer feeds paper to clean the internal rollers.

Print Quality Adjustment per Paper:

Depending on the paper type, ink feathering is differs. Select this feature if there is banding in the print outs or misalignment for a specific paper type.

Periodic Cleaning:

The printer automatically performs **Print Head Nozzle Check** and **Print Head Cleaning** based on the specific period of time. Select **On** to maintain premium print quality.

Related Information

- ➔ [“Adjusting the Print Quality” on page 267](#)
- ➔ [“Checking and Cleaning the Print Head” on page 231](#)
- ➔ [“Aligning Ruled Lines” on page 232](#)
- ➔ [“Cleaning the Paper Path for Ink Smears” on page 233](#)

Menu Options for Language

Select the menus on the control panel as described below.

Settings > Language

Preparing the Printer

Select the language used on the LCD screen.

Menu Options for Printer Status/Print

Select the menus on the control panel as described below.

Settings > Printer Status/Print

Print Status Sheet:

Configuration Status Sheet:

Print information sheets showing the current printer status and settings.

Supply Status Sheet:

Print information sheets showing the status of consumables.

Usage History Sheet:

Print information sheets showing the usage history of the printer.

PS3 Font List:

Print a list of fonts that are available for a PostScript printer.

PCL Font List:

Print a list of fonts that are available for a PCL printer.

Network:

Displays the current network settings.

Menu Options for Contacts Manager

Select the menus on the control panel as described below.

Settings > Contacts Manager

Register/Delete:

Register and/or delete contacts for the Fax, Scan to Email, and Scan to Network Folder/FTP menus.

Frequent:

Register frequently used contacts to access them quickly. You can also change the order of the list.

Print Contacts:

Print your contact list.

View Options:

Change the way the contact list is displayed.

Preparing the Printer

Search Options:

Change the method for searching contacts.

Menu Options for User Settings

Select the menus on the control panel as described below.

Settings > User Settings

You cannot change settings that have been locked by your administrator.

You can change the default settings of the following menus.

- Scan to Network Folder/FTP
- Scan to Email
- Scan to Memory Device
- Scan to Cloud
- Copy Settings
- Fax

Menu Options for Authentication Device Status

Select the menus on the control panel as described below.

Settings > Authentication Device Status

Displays the status of the authentication device.

Menu Options for Epson Open Platform Information

Select the menus on the control panel as described below.

Settings > Epson Open Platform Information

Displays the status of the Epson Open Platform.

Saving Power

The printer enters sleep mode or turns off automatically if no operations are performed for a set period. You can adjust the time before power management is applied. Any increase will affect the product's energy efficiency. Please consider the environment before making any change.

Depending on the location of purchase, the printer may have a feature that turns it off automatically if it is not connected to the network for 30 minutes.

Preparing the Printer

Saving Power - Control Panel

1. Select **Settings** on the home screen.
2. Select **General Settings** > **Basic Settings**.
3. Do one of the following.
 - Select **Sleep Timer** or **Power Off Settings** > **Power Off If Inactive** or **Power Off If Disconnected**, and then make settings.
 - Select **Sleep Timer** or **Power Off Timer**, and then make settings.

Note:

*Your product may have the **Power Off Settings** or **Power Off Timer** feature depending on the location of purchase.*

Fax Settings

Before Using Fax Features

Set up the following to use the fax features.

- Connect the printer correctly with the phone line and, if necessary, with a phone
- Complete the **Fax Setting Wizard**, which is required to make basic settings.

Set the following as necessary.

- Output destinations and related settings, such as network settings and mail server settings
- Contacts** registration
- User Settings** that define default values for **Fax** menu items
- Report Settings** to print reports when faxes are sent, received, or forwarded

Related Information

- ➔ [“Connecting to a Phone Line” on page 70](#)
- ➔ [“Making the Printer Ready to Send and Receive Faxes \(Using Fax Setting Wizard\)” on page 74](#)
- ➔ [“Making Settings Individually for Printer's Fax Features” on page 76](#)
- ➔ [“Menu Options for Fax Settings” on page 88](#)
- ➔ [“Network Settings” on page 98](#)
- ➔ [“Using an Email Server” on page 45](#)
- ➔ [“Managing Contacts” on page 49](#)
- ➔ [“Setting a Shared Folder” on page 52](#)
- ➔ [“Menu Options for User Settings” on page 68](#)
- ➔ [“Report Settings Menu” on page 94](#)

Connecting to a Phone Line

Compatible Telephone Lines

You can use the printer over standard analogue telephone lines (PSTN = Public Switched Telephone Network) and PBX (Private Branch Exchange) telephone systems.

You may not be able to use the printer with the following phone lines or systems.

- VoIP phone line such as DSL or fiber-optic digital service
- Digital phone line (ISDN)
- Some PBX telephone systems
- When adapters such as terminal adapters, VoIP adapters, splitters, or DSL router are connected between the telephone wall jack and the printer

Connecting the Printer to a Phone Line

Connect the printer to a telephone wall jack using an RJ-11 (6P2C) phone cable. When connecting a telephone to the printer, use a second RJ-11 (6P2C) phone cable.

Depending on the area, a phone cable may be included with the printer. If it is included, use that cable.

You may need to connect the phone cable to an adapter provided for your country or region.

Note:

Remove the cap from the EXT. port of the printer only when connecting your telephone to the printer. Do not remove the cap if you are not connecting your telephone.

In areas where lightning strikes occur frequently, we recommend that you use a surge protector.

Connecting to a Standard Phone Line (PSTN) or PBX

Connect a phone cable from the telephone wall jack or PBX port to the LINE port on the back of the printer.

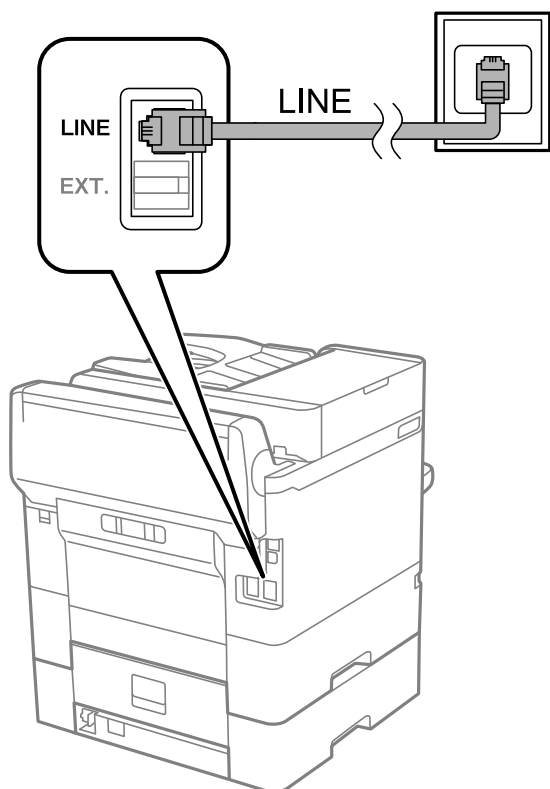

Connecting to DSL or ISDN

Connect a phone cable from the DSL modem or the ISDN terminal adapter to the LINE port on the back of the printer. See the documentation provided with the modem or the adapter for more details.

Fax Settings

Note:

If your DSL modem is not equipped with a built-in DSL filter, connect a separate DSL filter.

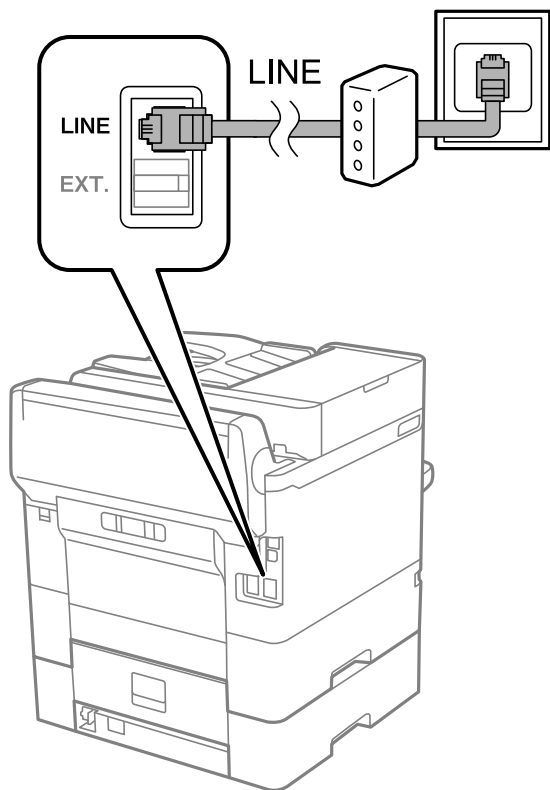

Connecting Your Phone Device to the Printer

When using the printer and your telephone on a single phone line, connect the telephone to the printer.

Note:

- If your phone device has a fax function, disable the fax function before connecting. See the manuals that came with the phone device for details.
- If you connect an answering machine, make sure the printer's **Rings to Answer** setting is set higher than the number of rings your answering machine is set to answer a call.

Fax Settings

1. Remove the cap from the EXT. port on the back of the printer.

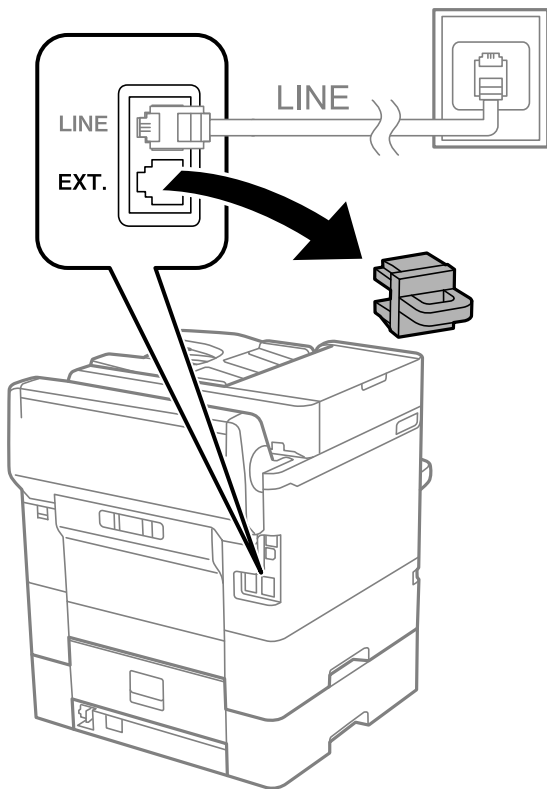

2. Connect the phone device and the EXT. port with a phone cable.

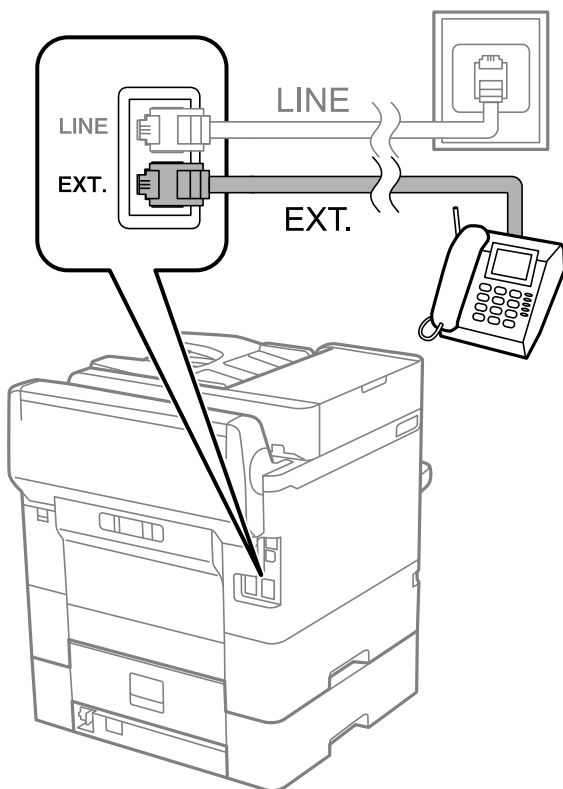

Fax Settings

Note:

When sharing a single phone line, make sure you connect the phone device to the EXT. port of the printer. If you split the line to connect the phone device and the printer separately, the phone and the printer do not work correctly.

3. Select **Fax** on the home screen.
4. Pick up the handset.

The connection is established when  (**Send**) is enabled as the following screen.

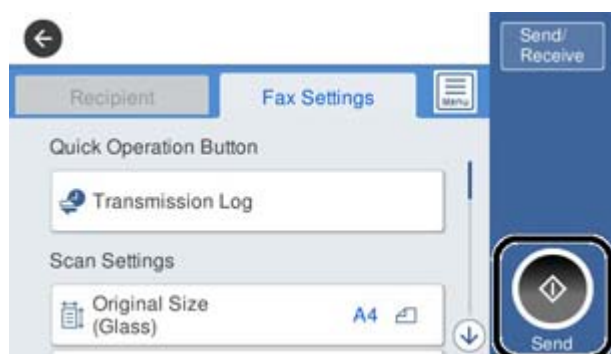

Related Information

- ➔ [“Making the Printer Ready to Send and Receive Faxes \(Using Fax Setting Wizard\)” on page 74](#)
- ➔ [“Making Settings to Use an Answering Machine” on page 78](#)
- ➔ [“Making Settings to Receive Faxes Operating Only a Connected Phone \(Remote Receive\)” on page 78](#)
- ➔ [“Setting Receive Mode” on page 76](#)

Making the Printer Ready to Send and Receive Faxes (Using Fax Setting Wizard)

Fax Setting Wizard configures the basic fax features to make the printer ready to send and receive faxes.

The Wizard is displayed automatically when the printer is turned on for the first time. You can also display the wizard manually from the printer's control panel. You need to run the wizard again in case the wizard is skipped when the printer is first turned on or when the connection environment has changed.

- The items below are what you can set through the wizard.
 - Header (Your Phone Number and Fax Header)**
 - Receive Mode (Auto or Manual)**
- The items below are set automatically according to the connection environment.
 - Dial Mode** (such as **Tone** or **Pulse**)
 - Line Type** (PSTN or PBX)
 - Dial Tone Detection**
 - Distinctive Ring Detection (DRD) Setting**
- Other items in **Basic Settings** remain as they are.

Start **Fax Setting Wizard** to make **Basic Settings**, following the on-screen instructions.

Fax Settings

1. Make sure the printer is connected to the phone line.

Note:

Because an automatic fax connection check runs at the end of the wizard, the printer must be connected to the phone line before starting the wizard.

2. Select **Settings** on the home screen on the printer's control panel, and then select **General Settings > Fax Settings > Fax Setting Wizard**.

3. On the **Confirmation** screen, tap **Proceed**.

The wizard begins.

4. On the fax header entry screen, enter the sender name such as your company name, and then tap **OK**.

Note:

Your sender name and your fax number appear as the header for outgoing faxes.

5. On the phone number entry screen, enter your fax number, and then tap **OK**.

6. On the **Distinctive Ring Detection (DRD) Setting** screen, make the following settings.

- If you have subscribed to a distinctive ring service from your telephone company: Select **Proceed**, and then select the ring pattern to be used for incoming faxes.

- If you select **All**, go to step 7.

- If you select any other setting, **Receive Mode** is automatically set to **Auto**. Go to step 9.

- If you do not need to set this option: Tap **Skip**, and then go to step 9.

Note:

- Distinctive ring services, offered by many telephone companies (the service name differs by company), allows you to have several phone numbers on one phone line. Each number is assigned a different ring pattern. You can use one number for voice calls and another for fax calls. Select the ring pattern assigned to fax calls in **DRD**.*

- Depending on the region, **On** and **Off** are displayed as the **DRD** options. Select **On** to use the distinctive ring feature.*

7. On the **Receive Mode Setting** screen, select whether you are using your phone device connected to the printer.

- When connected: Select **Yes**, and then go to the next step.

- When not connected: Select **No**, and then go to step 9. **Receive Mode** is set to **Auto**.

8. On the **Receive Mode Setting** screen, select whether you want to receive faxes automatically.

- To receive automatically: Select **Yes**. **Receive Mode** is set to **Auto**.

- To receive manually: Select **No**. **Receive Mode** is set to **Manual**.

9. On the **Proceed** screen, check the settings you made, and then tap **Proceed**.

To correct or change settings, tap .

10. On the **Run Check Fax Connection** screen, select **Start Checking** to run the fax connection check, and when the screen prompts you to print the check result, select **Print**.

A report of the check result that shows the connection status is printed.

Fax Settings

Note:

- ❑ If there are any errors reported, follow the instructions on the report to solve them.
- ❑ If the **Select Line Type** screen is displayed, select the line type.
 - When you are connecting the printer to a PBX phone system or terminal adapter, select **PBX**.
 - When you are connecting the printer to a standard phone line, select **PSTN**, and then select **Do Not Detect** on the **Confirmation** screen displayed. However, setting this to **Do Not Detect** may cause the printer to skip the first digit of a fax number when dialing and send the fax to the wrong number.

Related Information

- ➔ [“Connecting the Printer to a Phone Line” on page 71](#)
- ➔ [“Setting Receive Mode” on page 76](#)
- ➔ [“Making Settings to Use an Answering Machine” on page 78](#)
- ➔ [“Making Settings to Receive Faxes Operating Only a Connected Phone \(Remote Receive\)” on page 78](#)
- ➔ [“Basic Settings Menu” on page 94](#)

Making Settings Individually for Printer's Fax Features

You can configure the printer's fax features individually using the printer's control panel. The settings made using **Fax Setting Wizard** can also be changed. For more details, see the descriptions of the **Fax Settings** Menu.

Note:

- ❑ Using *Web Config*, you can configure the printer's fax features.
- ❑ When you use *Web Config* to display the **Fax Settings** menu, there may be slight differences in the user interface and in location compared to the printer's control panel.

Related Information

- ➔ [“Menu Options for Fax Settings” on page 88](#)

Setting Receive Mode

There are two options in **Receive Mode** for receiving incoming faxes. You can make settings in the menu below.

Settings > General Settings > Fax Settings > Basic Settings > Receive Mode

Receive Mode	Use of Phone Line
Manual	Mainly for phoning, but also for faxing
Auto	Only for faxing (external phone device is not required)
	Mainly for faxing, and sometimes phoning

Related Information

- ➔ [“Usage of Auto Mode” on page 77](#)
- ➔ [“Usage of Manual Mode” on page 77](#)
- ➔ [“Basic Settings Menu” on page 94](#)

Fax Settings

Usage of Manual Mode

Receiving Faxes

When the telephone rings, you can answer the ringing manually by picking up the handset.

- When you hear a fax signal (baud):

Select **Fax** on the printer's home screen, select **Send/Receive > Receive**, and then tap . Next, hang up the handset.

- If the ringing is for a voice call:

You can answer the phone as normal.

Receiving Faxes Using only a Connected Telephone

When **Remote Receive** is set, you can receive faxes by simply entering the **Start Code**.

When the telephone rings, pick up the handset. When you hear a fax tone (baud), dial the two digit **Start Code**, and then hang up the handset.

Related Information

- ➔ [“Making Settings to Receive Faxes Operating Only a Connected Phone \(Remote Receive\)” on page 78](#)

Usage of Auto Mode

Receiving Faxes Without an External Phone Device

The printer automatically switches to receive faxes when the number of rings you set in **Rings to Answer** is complete.

Note:

*We recommend setting **Rings to Answer** to as low a number as possible.*

Receiving Faxes With an External Phone Device

A printer with an external phone device works as follows.

- If your phone device is the answering machine and when it answers within the number of rings set in **Rings to Answer**:
 - If the ringing is for a fax: The printer automatically switches to receive faxes.
 - If the ringing is for a voice call: The answering machine can receive voice calls and record voice messages.
- When you pick up the handset within the number of rings set in **Rings to Answer**:
 - If the ringing is for a fax: You can receive the fax using the same steps as **Manual**.
 - If the ringing is for a voice call: You can answer the phone as normal.
- When the printer automatically switches to receive faxes:
 - If the ringing is for a fax: The printer starts receiving faxes.
 - If the ringing is for a voice call: You cannot answer the phone. Ask the person to call you back.

Note:

*Set the **Rings to Answer** settings of the printer to a higher number than the number of rings for the answering machine. Otherwise, the answering machine cannot receive voice calls to record voice messages. For details on setting up the answering machine, see the manual supplied with the answering machine.*

Fax Settings

Related Information

- ➔ [“Making Settings to Use an Answering Machine” on page 78](#)
- ➔ [“Usage of Manual Mode” on page 77](#)

Making Settings When You Connect an External Phone Device

Making Settings to Use an Answering Machine

You need settings to use an answering machine.

1. Select **Settings** on the home screen on the printer's control panel.
2. Select **General Settings > Fax Settings > Basic Settings**.
3. Set **Receive Mode** to **Auto**.
4. Set the **Rings to Answer** setting of the printer to a higher number than the number of rings for the answering machine.

If **Rings to Answer** is set lower than the number of rings for the answering machine, the answering machine cannot receive voice calls to record voice messages. See the manuals that came with the answering machine for its settings.

The printer's **Rings to Answer** setting may not be displayed, depending on the region.

Related Information

- ➔ [“Usage of Auto Mode” on page 77](#)
- ➔ [“Basic Settings Menu” on page 94](#)

Making Settings to Receive Faxes Operating Only a Connected Phone (Remote Receive)

You can start receiving incoming faxes by only picking up the handset and operating the phone, without operating the printer at all.

The **Remote Receive** feature is available for telephones that support tone dialing.

1. Select **Settings** on the home screen on the printer's control panel.
2. Select **General Settings > Fax Settings > Basic Settings > Remote Receive**.
3. Tap **Remote Receive** to set this to **On**.
4. Select **Start Code**, enter a two digit code (you can enter 0 to 9, *, and #), and then tap **OK**.
5. Select **OK** to apply the settings.

Related Information

- ➔ [“Usage of Manual Mode” on page 77](#)

Fax Settings

➔ [“Basic Settings Menu” on page 94](#)

Making Print Settings to Receive Faxes

Making Paper Source Settings to Receive Faxes (For Models with Two or More Paper Sources)

You can set the paper sources used for printing received documents and fax reports. By default, all of the paper sources are enabled for fax printing. Use this feature if you do not want to use paper in a specific paper source for fax printing.

1. Select **Settings** on the home screen on the printer's control panel.
2. Select **General Settings > Printer Settings > Paper Source Settings > Auto Select Settings > Fax**.
3. Tap each box of the paper source not to use for printing faxes.
The paper source setting is changed to **Off** and is disabled for printing faxes.

Related Information

➔ [“Printer Settings” on page 57](#)

Making Print Settings such as 2-Sided to Receive Faxes

You can set the printer to reduce paper by printing received faxes on both sides, or by printing them in reduced size to fit on paper. As an example, to set 2-Sided printing, follow the steps below.

1. Select **Settings** on the home screen on the printer's control panel.
2. Select **General Settings > Fax Settings > Receive Settings**.
3. Select **Print Settings**, and then select **2-Sided**.
4. Tap the **2-Sided** box to set this to **On**.
5. In **Binding Margin**, select **Short Side** or **Long Side**.
6. Select **OK**.

Related Information

➔ [“Print Settings Menu” on page 92](#)

Making Settings to Save and Forward Received Faxes

The printer is set to print received faxes by default. Besides printing, you can set the printer to save and/or forward received faxes. Note that the setting methods vary depending on whether the condition settings exist or not.

Fax Settings

- Saving and forwarding faxes received from unspecified partners - the features to save and forward received faxes without conditions
- Saving and forwarding faxes received from specific partners - the features to save and forward received faxes with conditions

Related Information

- ➔ [“Features to Save and Forward Received Faxes Without Condition” on page 80](#)
- ➔ [“Features to Save and Forward Received Faxes With Condition” on page 83](#)

Features to Save and Forward Received Faxes Without Condition

You can save and forward faxes received from unspecified partners to destinations in the printer and destinations other than the printer. You can select the below destinations at the same time. If you do select them all at the same time, the same received faxes are saved in the Inbox, on a computer, to an external memory device, and forwarded to a destination such as an email address.

Inbox in the Printer

You can save received faxes to the Inbox. You can view them on the printer's control panel so that you can print only the ones you want to print or delete unnecessary faxes.

Outside of the Printer

- A computer (PC-FAX reception)
- An external memory device
- Up to 5 Forwarding destinations
 - Email addresses
 - Shared folders on a network
 - Other fax machines

Related Information

- ➔ [“Setting Saving and Forwarding to Receive Faxes \(Unconditional Save/Forward\)” on page 80](#)
- ➔ [“Save/Forward Settings Menu” on page 89](#)
- ➔ [“Making Settings to Send and Receive Faxes on a Computer” on page 87](#)

Setting Saving and Forwarding to Receive Faxes (Unconditional Save/Forward)

You can make settings to save and forward received faxes from unspecified senders. If you make settings to forward received faxes, first add the forwarding destinations to the contacts list. To forward to an email address, you also need to configure the email server settings beforehand.

Follow the steps below. To make settings to save received faxes to a computer using the PC-FAX feature, see the related information below on this topic.

1. Select **Settings** on the home screen on the printer's control panel.

Fax Settings

2. Select **General Settings > Fax Settings > Receive Settings > Save/Forward Settings > Unconditional Save/Forward**.

When a message is displayed, check the content, and then tap **OK**.

3. Make the settings below depending on the saving and forwarding destinations.

The following options can be used at the same time.



- To save received faxes to the Inbox:
 - 1 Select **Save to Inbox** to set this to **On**.
 - 2 If a message is displayed, check the content, and then select **OK**.
- To save received faxes to an external memory device:
 - 1 Insert a memory device into the printer's external interface USB port.
 - 2 Select **Save to Memory Device**.
 - 3 Select **Yes**. To print the documents automatically while saving them in the memory device, select **Yes and Print** instead.
 - 4 Check the message that is displayed, and then tap **Create**.
A folder for saving received documents is created in the memory device.
 - 5 Check the message, tap **Close** or wait until the message is cleared, and then tap **Close**.
 - 6 When the next message is displayed, check it, and then tap **OK**.

! **Important:**

Received documents are saved in the printer's memory temporarily before the documents are saved in the memory device connected to the printer. Because a memory full error disables sending and receiving faxes, keep the memory device connected to the printer.

Fax Settings

- To forward received faxes to emails, shared folders, and other fax machines:

- ① Select **Forward**.
- ② Select **Yes**. To print the documents automatically while forwarding them, select **Yes and Print** instead.
- ③ Select **Add Entry**, and then select forwarding destinations from the contacts list. You can specify up to five forwarding destinations.
- ④ Tap **Close** to finish selecting forwarding destinations, and then tap **Close**.
- ⑤ In **Options When Forwarding Failed**, select whether to print received documents or save them in the printer's Inbox when forwarding fails.
- ⑥ Tap **OK**.



Important:

When the Inbox is full, receiving faxes is disabled. You should delete the documents from the inbox once they have been checked.

Note:

The number of documents that have failed to be forwarded is displayed on the  on the home screen, in addition to other unprocessed jobs.

4. Set the printer to send emails to someone you want to notify about the results of processed faxes, when necessary.

- ① Select **Email Notifications**.
- ② Tap the item below to set it to **On**.

The following options can be used at the same time.

- Notify on Receive: sends emails to the recipient when the printer has finished receiving faxes.
- Notify on Print: sends emails to the recipient when the printer has finished printing received faxes.
- Notify on Save: sends emails to the recipient when the printer has finished saving received documents to the memory device.
- Notify on Forward: sends emails to the recipient when the printer has finished forwarding received faxes.

- ③ Select the **Recipient** field, and then select a recipient for the email from the contact list.
- ④ Tap **Close** to finish selecting the recipient.
- ⑤ Tap **OK**.

5. Tap **Close** to complete the **Unconditional Save/Forward** settings.

This is the end of making unconditional saving and forwarding settings to receive faxes.

6. Select **Common Settings** as necessary.

For details, see the explanation for **Common Settings** in the **Save/Forward Settings** menu.

Note:

*If you have selected a shared folder on a network or an email address as the forwarding destination, we recommend that you test if you can send a scanned image to the destination in the scan mode. Select **Scan > Email**, or **Scan > Network Folder/FTP** from the home screen, select the destination, and then start scanning.*

Related Information

- ➔ [“Network Settings” on page 98](#)

Fax Settings

- ➔ “Setting a Shared Folder” on page 52
- ➔ “Features to Save and Forward Received Faxes Without Condition” on page 80
- ➔ “Making Save to Computer Setting to Receive Faxes” on page 87
- ➔ “Making Save to Computer Setting to Also Print on the Printer to Receive Faxes” on page 87
- ➔ “Making Save to Computer Setting not to Receive Faxes” on page 88
- ➔ “Save/Forward Settings Menu” on page 89

Features to Save and Forward Received Faxes With Condition

You can receive faxes from specified partners or receive faxes at a specified time, and then save and forward to destinations in the printer and destinations other than the printer. You can select the below destinations at the same time. If you do select them all at the same time, the same received faxes are saved to the Inbox, a confidential box, or an external memory device, and then forwarded to a destination such as an email address.

Inbox and Confidential Boxes in the Printer

You can save received faxes to the Inbox or confidential boxes, sorting them by conditions. You can view them on the printer's control panel, so that you can print only the faxes you want to print or delete unnecessary faxes.

Outside of the Printer

An external memory device

A forwarding destination:

- Email address
- Shared folder on a network
- Another fax machine

Related Information

- ➔ “Setting Saving and Forwarding to Receive Faxes (Conditional Save/Forward)” on page 83
- ➔ “Save/Forward Settings Menu” on page 89

Setting Saving and Forwarding to Receive Faxes (Conditional Save/Forward)

You can make settings to save and forward received faxes from a specified sender or at a specified time. If you make settings to forward received faxes, first add the forwarding destination to the contacts list. To forward to an email address, you also need to configure the email server settings beforehand.

Note:

- Color documents cannot be forwarded to another fax machine. They are processed as documents that failed to be forwarded.*
- Before you use the feature to save and forward received faxes at a specified time, make sure the printer's **Date/Time** and **Time Difference** settings are correct. Access the menu from **Settings > General Settings > Basic Settings > Date/Time Settings**.*

1. Select **Settings** on the home screen on the printer's control panel.
2. Select **General Settings > Fax Settings > Receive Settings > Save/Forward Settings**.
3. Tap  on an unregistered box under **Conditional Save/Forward**.

Fax Settings

4. Select the **Name** box and enter the name you want to register.
5. Select the **Condition(s)** box to make a condition setting.
 - Sender Fax Number match:** If the incoming fax number matches the conditions you selected in this item, the printer saves and forwards the received faxes.
Select the **Sender Fax Number match** condition and enter the fax number (max. 20 digits) by selecting the **Fax Number** box.
 - Subaddress(SUB) perfect match:** If the subaddress (SUB) is a perfect match, the printer saves and forwards the received faxes.
Enable the Subaddress(SUB) perfect match setting and enter the password by selecting the **Subaddress(SUB)** box.
 - Password(SID) perfect match:** If the password (SID) is perfectly matched, the printer saves and forwards the received faxes.
Enable the Password(SID) perfect match setting and input the password by selecting the **Password(SID)** box.
 - Receiving Time:** The printer saves and forwards received faxes during the specified time period.
Enable the **Receiving Time** setting and then set the time in **Start Time** and **End Time**.
6. Select the **Save/Forward Destination** box.
7. Make the settings below depending on the saving and forwarding destinations.
The following options can be used at the same time.

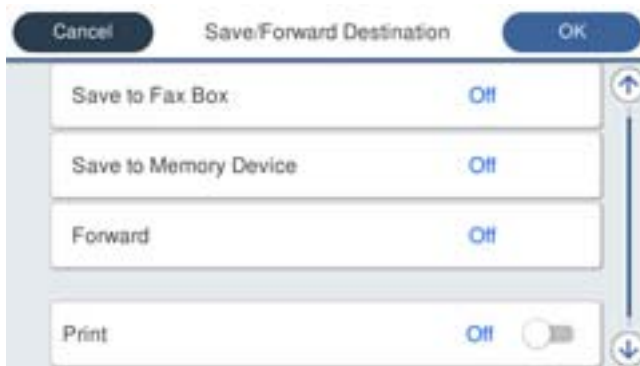

- To print received faxes:
Tap **Print** to set this to **On**.
- To save the received faxes to the Inbox or a confidential box:
 - ① Select **Save to Fax Box**.
 - ② Tap **Save to Fax Box** to set this to **On**.
 - ③ Select the box in which to save the document.

Fax Settings

- To save received faxes to an external memory device:
 - ➊ Insert a memory device into the printer's external interface USB port.
 - ➋ Select **Save to Memory Device**.
 - ➌ Tap **Save to Memory Device** to set this to **On**.
 - ➍ Check the message that is displayed, and then tap **Create**.

A folder for saving received documents is created in the memory device.



Important:

Received documents are saved in the printer's memory temporarily before the documents are saved in the memory device connected to the printer. Because a memory full error disables sending and receiving faxes, keep the memory device connected to the printer.

- To forward received faxes to emails, shared folders, and another fax machine:
 - ➊ Select **Forward**.
 - ➋ Tap **Forward** to set this to **On**.
 - ➌ Select **Add Entry**, and then select forwarding destinations from the contacts list. You can specify a forwarding destination.
 - ➍ When you have finished selecting forwarding destinations, tap **Close**.
 - ➎ Check that the forwarding destination you selected is correct, and then select **Close**.
 - ➏ In **Options When Forwarding Failed**, select whether to print received documents or save them in the printer's Inbox when forwarding fails.



Important:

When the Inbox or a confidential box is full, receiving faxes is disabled. You should delete the documents from the inbox once they have been checked.

Note:

The number of documents that have failed to be forwarded is displayed on the  on the home screen, in addition to other unprocessed jobs.

8. Tap **OK** to complete the **Save/Forward Destination** settings.
9. Set the printer to send emails to someone you want to notify about the results of processed faxes, when necessary.
 - ➊ Select **Email Notifications**.
 - ➋ Tap the item below to set it to **On**.

The following options can be used at the same time.

 - Notify on Receive: sends emails to the recipient when the printer has finished receiving faxes.
 - Notify on Print: sends emails to the recipient when the printer has finished printing received faxes.
 - Notify on Save: sends emails to the recipient when the printer has finished saving received documents to the memory device.
 - Notify on Forward: sends emails to the recipient when the printer has finished forwarding received faxes.
 - ➌ Select the **Recipient** field, and then select a recipient for the email from the contact list.
 - ➍ Tap **Close** to finish selecting the recipient.

Fax Settings

5 Tap **OK**.

10. Select **OK**, then select **OK** again to return to the **Save/Forward Settings** screen.
11. Select the registered box for which you made a condition setting, and then select **Enable**.
This is the end of making conditional saving and forwarding settings to receive faxes.
12. Select **Common Settings** as necessary.
For details, see the explanation for **Common Settings** in the **Save/Forward Settings** menu.

Note:

*If you have selected a shared folder on a network or an email address as the forwarding destination, we recommend that you test if you can send a scanned image to the destination in the scan mode. Select **Scan > Email**, or **Scan > Network Folder/FTP** from the home screen, select the destination, and then start scanning.*

Related Information

- ➔ [“Network Settings” on page 98](#)
- ➔ [“Using an Email Server” on page 45](#)
- ➔ [“Managing Contacts” on page 49](#)
- ➔ [“Setting a Shared Folder” on page 52](#)
- ➔ [“Features to Save and Forward Received Faxes With Condition” on page 83](#)
- ➔ [“Save/Forward Settings Menu” on page 89](#)

Making Settings for Blocking Junk Faxes

You can block junk faxes.

1. Select **Settings** on the home screen on the printer's control panel.
2. Select **General Settings > Fax Settings > Basic Settings > Rejection Fax**.
3. Set the condition to block junk faxes.
Select **Rejection Fax**, and then enable the following options.
 - Rejection Number List: Rejects faxes that are in the Rejection Number List.
 - Fax Header Blank: Rejects faxes that have blank header information.
 - Unregistered Contacts: Rejects faxes that have not been added to the contact list.
4. Tap  to return to the **Rejection Fax** screen.
5. If you are using the **Rejection Number List**, select **Edit Blocked Number list**, and then edit the list.

Related Information

- ➔ [“Basic Settings Menu” on page 94](#)

Making Settings to Send and Receive Faxes on a Computer

To send and receive faxes on a client computer, FAX Utility must be installed on the computer connected by network or USB cable .

Enabling Sending Faxes from a Computer

Set up the following using Web Config.

1. Access Web Config, click the **Fax** tab, and then click **Send Settings > Basic**.
2. Select **Use** for the **PC to FAX Function**.

Note:

*The default setting value of the PC to FAX Function is Use. To disable sending faxes from any computer, select **Do Not Use**.*

3. Click **OK**.

Related Information

➔ [“Send Settings Menu” on page 88](#)

Making Save to Computer Setting to Receive Faxes

You can receive faxes on a computer by using the FAX Utility. Install FAX Utility on the client computer and make the setting. For details, see Basic Operations in the FAX Utility help (displayed on the main window).

The setting item below on the printer's control panel is set to **Yes**, and the faxes received can be saved on the computer.

Settings > General Settings > Fax Settings > Receive Settings > Save/Forward Settings > Unconditional Save/Forward > Save to Computer

Related Information

➔ [“Save/Forward Settings Menu” on page 89](#)

Making Save to Computer Setting to Also Print on the Printer to Receive Faxes

You can make the setting to print received faxes on the printer as well as save them on a computer.

1. Select **Settings** on the home screen on the printer's control panel.
2. Select **General Settings > Fax Settings > Receive Settings**.
3. Select **Save/Forward Settings > Unconditional Save/Forward > Save to Computer > Yes and Print**.

Related Information

➔ [“Save/Forward Settings Menu” on page 89](#)

Fax Settings

Making Save to Computer Setting not to Receive Faxes

To set the printer not to save received faxes on the computer, change the settings on the printer.

Note:

You can also change the settings using the FAX Utility. However, if there are any faxes that have been unsaved to the computer, the feature does not work.

1. Select **Settings** on the home screen on the printer's control panel.
2. Select **General Settings** > **Fax Settings** > **Receive Settings**.
3. Select **Save/Forward Settings** > **Unconditional Save/Forward** > **Save to Computer** > **No**.

Related Information

➔ [“Save/Forward Settings Menu” on page 89](#)

Menu Options for Fax Settings

Selecting **Settings** > **General Settings** > **Fax Settings** from the printer's control panel displays this menu.

Note:

- You can also access Fax Settings from Web Config. Click the **Fax** tab on the Web Config screen.
- When you use Web Config to display the **Fax Settings** menu, there may be slight differences in the user interface and in location compared to the printer's control panel.

Quick Operation Button Menu

You can find the menu on the printer's control panel below:

Settings > **General Settings** > **Fax Settings** > **Quick Operation Button**

Note:

You cannot display this menu on the Web Config screen.

Item	Description
Quick Operation Button 1	Registers up to three shortcuts allowing you to quickly access the menu you use often when sending faxes. The shortcuts are located at the top of the Fax Settings tab in Fax .
Quick Operation Button 2	
Quick Operation Button 3	

Send Settings Menu

You can find the menu on the printer's control panel below:

Fax Settings

Settings > General Settings > Fax Settings > Send Settings

Note:

On the Web Config screen, you can find the menu below:

Fax tab > Send Settings > Basic

Item	Description
Quick memory send	The quick memory send feature starts sending the fax when the printer finishes scanning the first page. If you do not enable this feature, the printer starts sending after saving all of the scanned images to memory. By using this feature you can reduce the overall operation time as scanning and sending are performed in parallel.
Batch Send	When there are multiple faxes waiting to be sent to the same recipient, this groups them together to send them at once. Up to five documents (up to 100 pages in total) can be sent at one time. This helps you save on transmission costs by reducing the number of connection times.
Save Failure Data	Saves documents that failed to be sent in the printer's memory. You can resend the documents from the Job/Status .
PC to FAX Function	This item is displayed on the Web Config screen only. Enables sending faxes using a client computer.

Related Information

➔ [“Enabling Sending Faxes from a Computer” on page 87](#)

Receive Settings Menu

Related Information

➔ [“Save/Forward Settings Menu” on page 89](#)

➔ [“Print Settings Menu” on page 92](#)

Save/Forward Settings Menu

You can find the menu on the printer's control panel below:

Settings > General Settings > Fax Settings > Receive Settings > Save/Forward Settings

Unconditional Save/Forward

Note:

On the Web Config screen, you can find the menu below:

Fax tab > Receive Settings > Fax Output

You can set saving and forwarding destinations to the Inbox, a computer, an external memory device, email addresses, shared folders, and other fax machines. You can use these features at the same time. If you set all items to **Off** on the printer's control panel, the printer is set to print received faxes.

Fax Settings

Item	Description
Save to Inbox	<p>Saves received faxes to the printer's Inbox. Up to 200 documents can be saved. Note that saving 200 documents may not be possible depending on the usage conditions such as the file size of saved documents, and using of multiple fax saving features at a time.</p> <p>Though the received faxes are not automatically printed, you can view them on the printer's screen and print only the ones you need. However, if you select Yes and Print in another item, such as Save to Computer in Unconditional Save/Forward, the received faxes are printed automatically.</p>
Save to Computer	<p>Saves received faxes as PDF files on a computer connected to the printer. You can set this to Yes by using only the FAX Utility. Install FAX Utility on the computer in advance. After setting this to Yes, you can change this to Yes and Print.</p>
Save to Memory Device	<p>Saves received faxes as PDF files to an external memory device connected to the printer. Selecting Yes and Print prints received faxes while saving them to the memory device.</p> <p>Received documents are saved in the printer's memory temporarily before the documents are saved in the memory device connected to the printer. Because a memory full error disables sending and receiving faxes, keep the memory device connected to the printer.</p>
Forward	<p>Forwards received faxes to another fax machine, or forwards them as PDF files to a shared folder on a network or to an email address. Forwarded faxes are deleted from the printer. Selecting Yes and Print prints received faxes while forwarding them. First add the forwarding destinations to the contacts list. To forward to an email address, configure the email server settings.</p> <p><input type="checkbox"/> Destination: You can select forwarding destinations from the contacts list you added in advance.</p> <p>If you have selected a shared folder on a network or an email address as the forwarding destination, we recommend that you test if you can send a scanned image to the destination in the scan mode. Select Scan > Email, or Scan > Network Folder/FTP from the home screen, select the destination, and then start scanning.</p> <p><input type="checkbox"/> Options When Forwarding Failed: You can select whether to print the failed fax or save it to the Inbox.</p> <p>When the Inbox is full, receiving faxes is disabled. You should delete the documents from the inbox once they have been checked. The number of documents that have failed to be forwarded is displayed on the  on the home screen, in addition to other unprocessed jobs.</p>
Email Notifications	<p>Sends an email notification when the process you select below is complete. You can use the features below at the same time.</p> <p><input type="checkbox"/> Recipient: Set the destination of the process completion notification.</p> <p><input type="checkbox"/> Notify on Receive: Sends a notification when receiving a fax is complete.</p> <p><input type="checkbox"/> Notify on Print: Sends a notification when printing a fax is complete.</p> <p><input type="checkbox"/> Notify on Save: Sends a notification when saving a fax to a memory device is complete.</p> <p><input type="checkbox"/> Notify on Forward: Sends a notification when forwarding a fax is complete.</p>

Conditional Save/Forward

Note:

On the Web Config screen, you can find the menu below:

Fax tab > Receive Settings > Conditions Output Settings

You can set saving and/or forwarding destinations to the Inbox, confidential boxes, an external memory device, email addresses, shared folders, and another fax machine.

Fax Settings

To switch between enabling or disabling the conditions, tap anywhere in the box except for .

Item	Description
Name	Enter name of the condition.
Condition(s)	<p>Select the conditions and make the settings.</p> <ul style="list-style-type: none"> <input type="checkbox"/> Sender Fax Number match: When the sender fax number matches, the received fax is saved and forwarded. <input type="checkbox"/> Subaddress(SUB) perfect match: When the subaddress (SUB) matches perfectly, the received fax is saved and forwarded. <input type="checkbox"/> Password(SID) perfect match: When the password (SID) matches perfectly, the received fax is saved and forwarded. <input type="checkbox"/> Receiving Time: Saves and forwards a fax received during the specified period of time.
Save/Forward Destination	<p>Select the destination to save and forward received documents that match the conditions. You can use the features below at the same time.</p> <ul style="list-style-type: none"> <input type="checkbox"/> Save to Fax Box: Saves received faxes in the printer's Inbox or confidential box. You can save up to 200 documents in total. Note that saving 200 documents may not be possible depending on the usage conditions such as the file size of saved documents, and using of multiple fax saving features at a time. <input type="checkbox"/> Save to Memory Device: Saves received faxes as PDF files to an external memory device connected to the printer. Received documents are saved in the printer's memory temporarily before the documents are saved in the memory device connected to the printer. Because a memory full error disables sending and receiving faxes, keep the memory device connected to the printer. <input type="checkbox"/> Forward: Forwards received faxes to another fax machine, or forwards them as PDF files to a shared folder on a network or to an email address. Forwarded faxes are deleted from the printer. First add the forwarding destination to the contacts list. To forward to an email address, you also need to configure the email server settings. <ul style="list-style-type: none"> <input type="checkbox"/> Destination: You can select a forwarding destination from the contacts list you added in advance. If you have selected a shared folder on a network or an email address as the forwarding destination, we recommend that you test if you can send a scanned image to the destination in the scan mode. Select Scan > Email, or Scan > Network Folder/FTP from the home screen, select the destination, and then start scanning. <input type="checkbox"/> Options When Forwarding Failed: You can select whether to print the failed fax or save it to the Inbox. <input type="checkbox"/> Print: Prints received faxes.
Email Notifications	<p>Sends an email notification when the process you select below is complete. You can use the features below at the same time.</p> <ul style="list-style-type: none"> <input type="checkbox"/> Recipient: Set the destination of the process completion notification. <input type="checkbox"/> Notify on Receive: Sends a notification when receiving a fax is complete. <input type="checkbox"/> Notify on Print: Sends a notification when printing a fax is complete. <input type="checkbox"/> Notify on Save: Sends a notification when saving a fax to a memory device is complete. <input type="checkbox"/> Notify on Forward: Sends a notification when forwarding a fax is complete.

Fax Settings

Item	Description
Transmission Report	Prints a transmission report automatically after you save or forward a received fax. Selecting Print on Error prints a report only when you save or forward a received fax and an error occurs.

Common Settings

Note:

On the Web Config screen, you can find the menu below:

- Fax tab > Receive Settings > Inbox
- Fax tab > Receive Settings > Fax Output

Item	Description
Inbox settings	<ul style="list-style-type: none"> <input type="checkbox"/> Options when memory is full: You can select the operation to print the received fax or refuse to receive it when the Inbox memory is full. <input type="checkbox"/> Inbox Password Settings: Password protects the Inbox to restrict users from viewing received faxes. Select Change to change the password, and select Reset to cancel password protection. When changing or resetting the password, you need the current password. You cannot set a password when Options when memory is full has been set to Receive and print faxes.
Email Subject to Forward	You can specify a subject for the email when forwarding to an email address.



(Menu)

Note:

You cannot print the list from the Web Config screen.

Item	Description
Print Conditional Save/Forward list	Prints the Conditional Save/Forward list.

Related Information

- ➔ [“Features to Save and Forward Received Faxes Without Condition” on page 80](#)
- ➔ [“Setting Saving and Forwarding to Receive Faxes \(Unconditional Save/Forward\)” on page 80](#)
- ➔ [“Features to Save and Forward Received Faxes With Condition” on page 83](#)
- ➔ [“Setting Saving and Forwarding to Receive Faxes \(Conditional Save/Forward\)” on page 83](#)

Print Settings Menu

You can find the menu on the printer's control panel below:

Settings > General Settings > Fax Settings > Receive Settings > Print Settings

Note:

On the Web Config screen, you can find the menu below:

Fax tab > Receive Settings > Fax Output

Fax Settings

Item	Description
Auto Reduction	Prints received faxes with large-size documents reduced to fit on the paper in the paper source. Reducing may not always be possible depending on the received data. If this is turned off, large documents are printed at their original size on multiple sheets, or a blank second page may be ejected.
Split Page Settings	Prints received faxes with the page split when the size of the received documents is larger than the size of the paper loaded in the printer.
Acting Print	Make print settings when the document size of the received fax is larger than the size of the paper loaded in the printer. Selecting On(Split to pages) splits the document longitudinally to print the received document. Selecting On (Reduce to Fit) reduces to a 50 % minimum to print.
Auto Rotation	Rotates faxes received as landscape-orientated, A5 size documents so that they are printed on A5 size paper. This setting is applied when the paper size setting for at least one paper source used for printing faxes is set to A5. Selecting Off , faxes received as landscape-orientated A5 size, the same width as A4 portrait documents, are assumed and printed as A4 size faxes. Check the paper source settings for printing faxes and paper size for the paper sources in the following menus in Settings > General Settings > Printer Settings > Paper Source Settings . <input type="checkbox"/> Auto Select Settings <input type="checkbox"/> Paper Setting > Paper Size
Add Reception Information	Prints reception information in the received fax, even if the sender does not set the header information. The reception information includes the received date and time, sender's ID, reception ID (such as "#001"), and page number (such as "P1"). When Split Page Settings is enabled, the split page number is also included.
2-Sided	Prints multiple pages of received faxes on both sides of the paper.
Print Start Timing	Select options to start printing the faxes to receive. <input type="checkbox"/> All Pages Received: Printing starts after receiving all of the pages. To start printing from the first page or last page depends on the setting of Collation Stack feature. See the explanation for Collation Stack . <input type="checkbox"/> First Page Received: Starts printing when the first page is received, and then prints in order as the pages are received. If the printer cannot start printing, such as when it is printing other jobs, the printer starts printing received pages as a batch when it is available.
Collation Stack	Since the first page is printed last (output to the top), the printed documents are stacked in the correct page order. When the printer is running low on memory, this feature may not be available.
Print Suspend Time	<input type="checkbox"/> Print Suspend Time: During the specified time period, the printer saves documents received in the printer's memory without printing them. This feature can be used for noise prevention at night or to prevent confidential documents from being disclosed while you are away. Before using this feature, make sure there is enough free memory. Even before the restarting time, you can check and print the received documents individually from Job/Status on the home screen. <input type="checkbox"/> Time to Stop: Stops printing documents. <input type="checkbox"/> Time to Restart: Restarts printing documents automatically.
Quiet Mode	Reduces the noise the printer makes when printing faxes, however, print speed may be reduced.

Fax Settings

Related Information

➔ [“Making Print Settings to Receive Faxes” on page 79](#)

Report Settings Menu

You can find the menu on the printer's control panel below:

Settings > General Settings > Fax Settings > Report Settings

Note:

On the Web Config screen, you can find the menu below:

Fax tab > Report Settings

Item	Description
Forwarding Report	Prints a report after forwarding a received fax document. Select Print to print every time a document is forwarded.
Backup Error Report	Prints a report when a backup error occurs on forwarding the sent fax to Backup Destination . You can set the destination in Fax > Fax Settings > Backup . Note that the backup feature is available when: <ul style="list-style-type: none"> <input type="checkbox"/> Sending a fax in monochrome <input type="checkbox"/> Sending a fax using the Send Fax Later feature <input type="checkbox"/> Sending a fax using the Batch Send feature <input type="checkbox"/> Sending a fax using the Store Fax Data feature
Fax Log Auto Print	Prints the fax log automatically. Select On(Every 30) to print a log every time 30 fax jobs are completed. Select On(Time) to print the log at a specified time. However, if the number of fax jobs exceeds 30, the log is printed before the specified time.
Attach Fax image to report	Prints a Transmission Report with an image of the first page of the sent document. Select On(Large Image) to print the upper part of the page without reducing. Select On(Small Image) to print the entire page reducing it to fit onto the report.
Report Format	Selects a format for fax reports in Fax > More tab > Fax Report other than Protocol Trace . Select Detail to print with error codes.
Output Method	Select an output method for fax reports, such as Save to Memory Device . When you select Forward , select Destination from the contacts.

Basic Settings Menu

You can find the menu on the printer's control panel below:

Settings > General Settings > Fax Settings > Basic Settings

Note:

On the Web Config screen, you can find the menu below:

- Fax tab > Line Settings**
- Fax tab > Send Settings > Basic**
- Fax tab > Receive Settings > Basic**
- Fax tab > Receive Settings > Fax Block Settings**

Fax Settings

Item	Description
Fax Speed	Select the fax transmission speed. We recommend selecting Slow(9,600bps) when a communication error occurs frequently, when sending/receiving a fax to/from abroad, or when you are using an IP (VoIP) phone service.
ECM	Automatically corrects errors in the fax transmission (Error Correction Mode), mostly caused by telephone line noise. If this is disabled, you cannot send or receive documents in color.
Dial Tone Detection	Detects a dial tone before starting to dial. If the printer is connected to a PBX (Private Branch Exchange) or digital phone line, the printer may fail to start dialing. In this situation, change the Line Type setting to PBX . If this does not work, disable this feature. However, disabling this feature may drop the first digit of a fax number and send the fax to the wrong number.
Dial Mode	Select the type of phone system to which you have connected the printer. When set to Pulse , you can temporarily switch the dialing mode from pulse to tone by pressing * ("T" is entered) while entering numbers on the fax top screen. This setting may not be displayed depending on your region or country.
Line Type	Select the line type to which you have connected the printer. When using the printer in an environment that uses extensions and requires an external access code, such as 0 and 9, to get an outside line, select PBX and register the access code. Once you have registered the access code, enter # (hash) instead of the access code when sending a fax to an outside fax number. For an environment that uses a DSL modem or terminal adapter, setting to PBX is also recommended. You cannot send faxes to recipients in Contacts in which an external access code such as 0 or 9 is set. If you have added recipients in Contacts using an external access code such as 0 or 9, set the Access Code to Do Not Use . Otherwise, you must change the code to # in Contacts .
Header	Enter your sender name and fax number. These appear as a header on outgoing faxes. <input type="checkbox"/> Your Phone Number: You can enter up to 20 characters using 0-9 + or space. For Web Config, you can enter up to 30 characters. <input type="checkbox"/> Fax Header: You can register up to 21 sender names as necessary. You can enter up to 40 characters for each sender name. For Web Config, enter the header in Unicode (UTF-8).
Receive Mode	Select the receive mode. For details, see the related Information below.
DRD	If you have subscribed to a distinctive ring service from your telephone company, select the ring pattern to be used for incoming faxes. The distinctive ring service, offered by many telephone companies (the service name differs by company), allows you to have several phone numbers on one phone line. Each number is assigned different ring pattern. You can use one number for voice calls and another for fax calls. Depending on the region, this option may be On or Off .
Rings to Answer	Select the number of rings that must occur before the printer automatically receives a fax.
Remote Receive	<input type="checkbox"/> Remote Receive: When you answer an incoming fax call on a phone connected to the printer, you can start receiving the fax by entering the code using the phone. <input type="checkbox"/> Start Code: Set the start code of Remote Receive . Enter two characters using 0-9, *, #.

Fax Settings

Item	Description
Rejection Fax	<input type="checkbox"/> Rejection Fax: Select options to reject receiving junk faxes. <ul style="list-style-type: none"> <input type="checkbox"/> Rejection Number List: If the other party's phone number is in the rejection number list, set whether to reject the incoming faxes. <input type="checkbox"/> Fax Header Blank: If the other party's phone number is blocked, set whether to reject receiving the faxes. <input type="checkbox"/> Unregistered Contacts: If the other party's phone number is not in the contacts, set whether to reject receiving the faxes. <input type="checkbox"/> Edit Blocked Number list: You can register up to 30 fax numbers to reject the faxes and calls. Enter up to 20 characters using 0-9, *, #, or space.

Related Information

- ➔ [“Making the Printer Ready to Send and Receive Faxes \(Using Fax Setting Wizard\)” on page 74](#)
- ➔ [“Setting Receive Mode” on page 76](#)
- ➔ [“Making Settings to Receive Faxes Operating Only a Connected Phone \(Remote Receive\)” on page 78](#)
- ➔ [“Making Settings for Blocking Junk Faxes” on page 86](#)

Security Settings Menu

You can find the menu on the printer's control panel below:

Settings > General Settings > Fax Settings > Security Settings

Note:

On the *Web Config* screen, you can find the menu below:

Fax tab > Security Settings

Item	Description
Direct Dialing Restrictions	Selecting On disables manual entry of the recipient's fax numbers allowing the operator to select recipients only from the contacts list or sent history. Selecting Enter Twice requires the operator to enter the fax number again when the number was manually entered. Selecting Off enables manual entry of the recipient's fax numbers.
Confirm Address List	Selecting On displays a recipient confirmation screen before starting the transmission.
Backup Data Auto Clear	Selecting On automatically erases the backups when sending or receiving a document completes successfully and the backups become unnecessary. Selecting Off , to prepare for an unexpected power off due to an electricity failure or an incorrect operation, temporarily stores backup copies of sent and received documents in its memory.
Clear Backup Data	Erases all backup copies temporarily stored in the printer's memory. Run this before you give the printer to someone else or dispose of it. This menu is not displayed on the <i>Web Config</i> screen.

Fax Settings

Check Fax Connection

You can find the menu on the printer's control panel below:

Settings > General Settings > Fax Settings > Check Fax Connection

Note:

You cannot display this menu on the Web Config screen.

Selecting **Check Fax Connection** checks that the printer is connected to the phone line and ready for fax transmission. You can print the check result on A4 size plain paper.

Fax Setting Wizard

You can find the menu on the printer's control panel below:

Settings > General Settings > Fax Settings > Fax Setting Wizard

Note:

You cannot display this menu on the Web Config screen.

Selecting **Fax Setting Wizard** makes basic fax settings. Follow the on-screen instructions.

Related Information

➔ [“Making the Printer Ready to Send and Receive Faxes \(Using Fax Setting Wizard\)” on page 74](#)

Network Settings

Network Connection Types

You can use the following connection methods.

Ethernet Connection

Connect the printer to a hub with an Ethernet cable.

See *Administrator's Guide* to assign a static IP address.

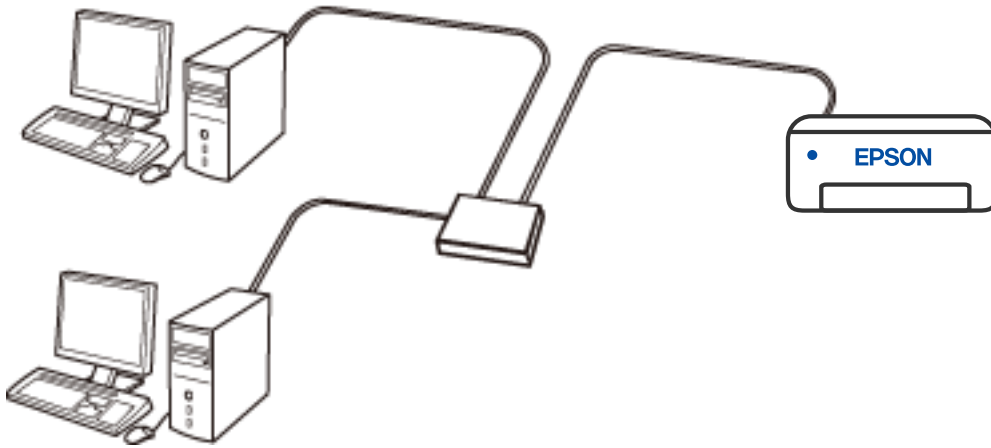

Related Information

➔ [“Making Advanced Network Settings” on page 113](#)

Wi-Fi Connection

Connect the printer and the computer or smart device to the wireless router. This is the typical connection method for home or office networks where computers are connected by Wi-Fi through the wireless router.

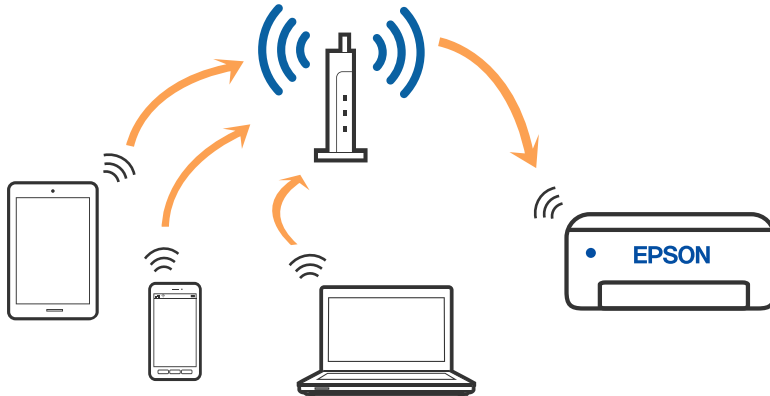

Related Information

- ➔ [“Connecting to a Computer” on page 100](#)
- ➔ [“Connecting to a Smart Device” on page 101](#)
- ➔ [“Making Wi-Fi Settings from the Printer” on page 110](#)

Wi-Fi Direct (Simple AP) Connection

Use this connection method when you are not using Wi-Fi at home or at the office, or when you want to connect the printer and the computer or smart device directly. In this mode, the printer acts as an wireless router and you can connect the devices to the printer without having to use a standard wireless router. However, devices directly connected to the printer cannot communicate with each other through the printer.

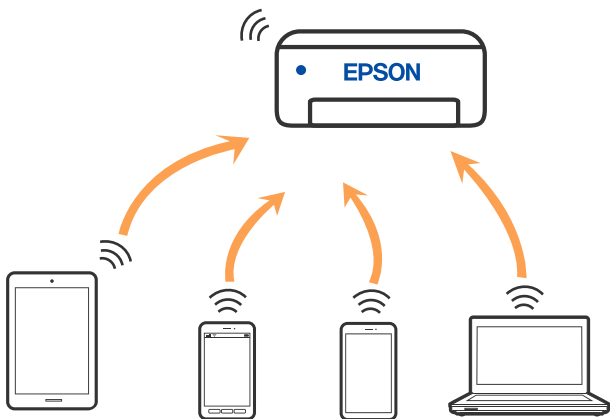

The printer can be connected by Wi-Fi or Ethernet, and Wi-Fi Direct (Simple AP) connection simultaneously. However, if you start a network connection in Wi-Fi Direct (Simple AP) connection when the printer is connected by Wi-Fi, the Wi-Fi is temporarily disconnected.

Network Settings

Related Information

- ➔ “Connecting to an iPhone or iPad (iOS devices) using Wi-Fi Direct” on page 101
- ➔ “Connecting to Android Devices using Wi-Fi Direct” on page 104
- ➔ “Connecting to Devices other than iOS and Android using Wi-Fi Direct” on page 106

Connecting to a Computer

We recommend using the installer to connect the printer to a computer. You can run the installer using one of the following methods.

- Setting up from the website
 - Access the following website, and then enter the product name. Go to **Setup**, and then start setting up.
<http://epson.sn>
- Setting up using the software disc (only for the models that come with a software disc and users with Windows computers with disc drives.)
 - Insert the software disc into the computer, and then follow the on-screen instructions.

Selecting the Connection Methods

Follow the on-screen instructions until the following screen is displayed, and then select the connection method of the printer to the computer.

Select the connection type and then click **Next**.

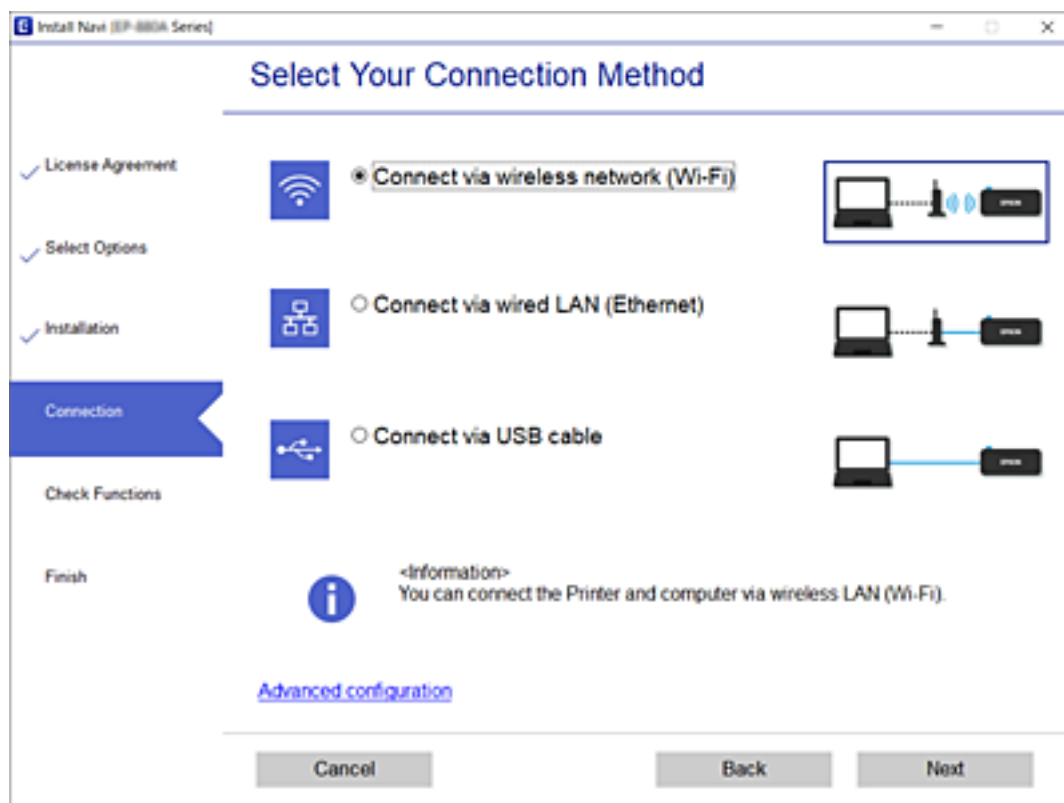

Follow the on-screen instructions.

Connecting to a Smart Device

Connecting to a smart device over a wireless router

You can use the printer from a smart device when you connect the printer to the same Wi-Fi network (SSID) as the smart device. To use the printer from a smart device, set up from the following website. Access to the website from the smart device that you want to connect to the printer.

<http://epson.sn> > Setup

Note:

If you want to connect a computer and a smart device to the printer at the same time, we recommend connecting the computer first.

Related Information

➔ [“Printing from Smart Devices” on page 162](#)

Connecting to an iPhone or iPad (iOS devices) using Wi-Fi Direct

This method allows you to connect the printer directly to an iPhone or iPad without a wireless router. The following conditions are required to use this function. If your environment does not match these conditions, you can connect by selecting **Other OS Devices**. See the related information link below for details on connecting.

- iOS 11 or later
- Using the standard camera application to scan the QR code
- Epson iPrint version 7.0 or later

Epson iPrint is used to print from a smart device. Install Epson iPrint on the smart device in advance.

Note:

You only need to make these settings for the printer and the smart device that you want to connect to once. Unless you disable Wi-Fi Direct or restore the network settings to their defaults, you do not need to make these settings again.

1. Tap  |  on the home screen.
2. Tap **Wi-Fi Direct**.
3. Tap **Start Setup**.

Network Settings

4. Tap iOS.

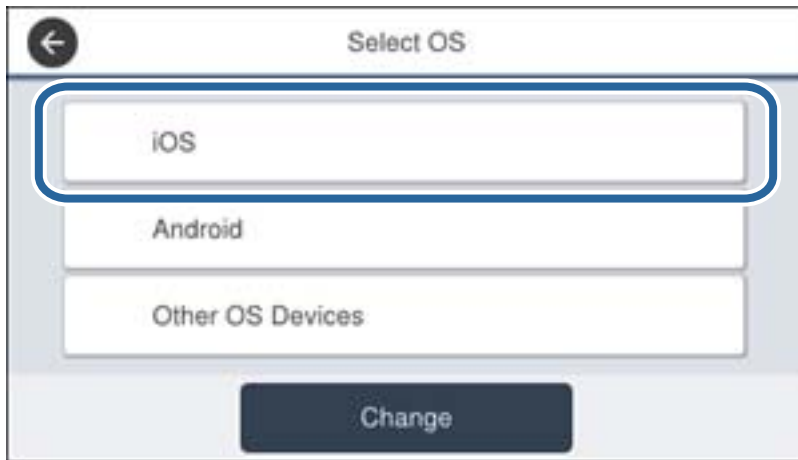

The QR code is displayed on the printer's control panel.

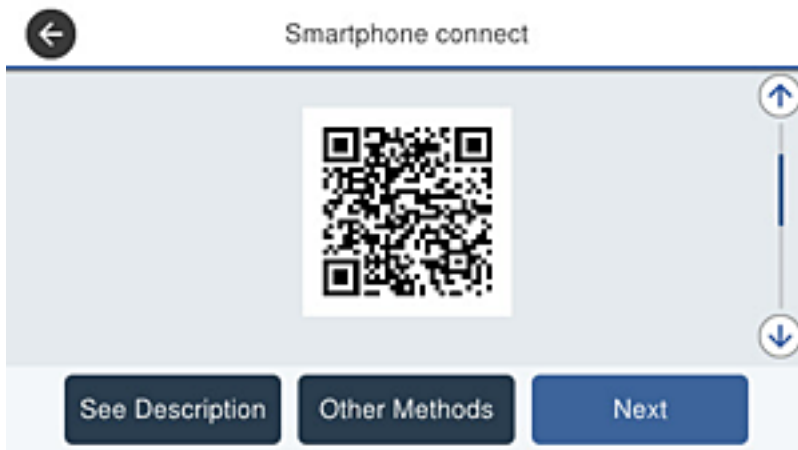

5. On your iPhone or iPad, start the standard Camera app, and then scan the QR code displayed on the printer's control panel.

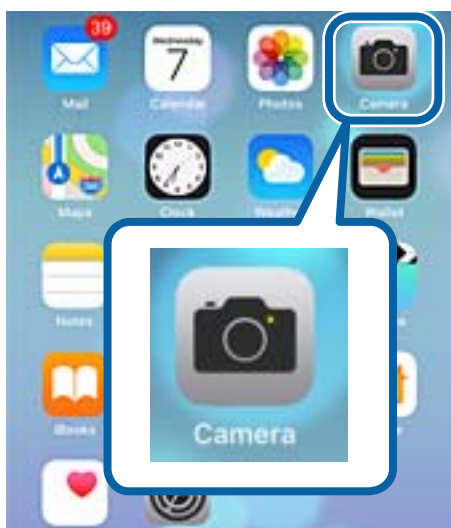

Network Settings

Use the Camera app for iOS 11 or later. You cannot connect to the printer using the Camera app for iOS 10 or earlier. Also, you cannot connect using an app for scanning QR codes. If you cannot connect, scroll the screen on the printer's control panel, and then select **Other OS Devices**. See the related information link below for details on connecting.

6. Tap the message displayed on the smart device's screen.

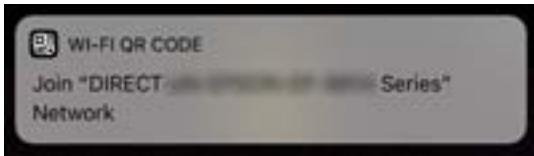

7. Tap **Join**.

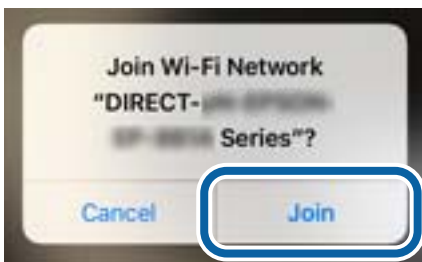

8. On the printer's control panel, select **Next**.
9. On the iPhone or iPad, start Epson iPrint.



10. On the Epson iPrint screen, tap **Printer is not selected..**
11. Select the printer that you want to connect to.



Network Settings

See the information displayed on the printer's control panel to select the printer.



12. On the printer's control panel, select **Complete**.

For smart devices that have been connected to the printer before, select the network name (SSID) on the smart device's Wi-Fi screen to connect them again.

Related Information

- ➔ [“Connecting to Devices other than iOS and Android using Wi-Fi Direct” on page 106](#)
- ➔ [“Printing from Smart Devices” on page 162](#)

Connecting to Android Devices using Wi-Fi Direct



This method allows you to connect the printer directly to your Android device without a wireless router. The following conditions are required to use this function.

- Android 4.4 or later
- Epson iPrint version 7.0 or later

Epson iPrint is used to print from a smart device. Install Epson iPrint on the smart device in advance.

Note:

You only need to make these settings for the printer and the smart device that you want to connect to once. Unless you disable Wi-Fi Direct or restore the network settings to their defaults, you do not need to make these settings again.

1. Tap  |  on the home screen.
2. Tap **Wi-Fi Direct**.
3. Tap **Start Setup**.

Network Settings

4. Tap **Android**.

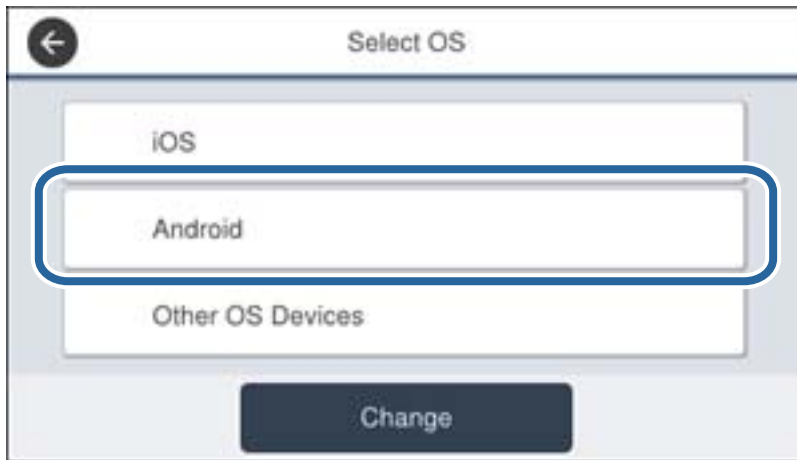

5. On the smart device, start Epson iPrint.



6. On the Epson iPrint screen, tap **Printer is not selected..**
7. Select the printer that you want to connect to.



Network Settings

See the information displayed on the printer's control panel to select the printer.



Note:

Printers may not be displayed depending on the Android device. If printers are not displayed, connect by selecting **Other OS Devices**. See the related information link below for connecting.

8. When the device connection approval screen is displayed, select **Approve**.
9. When the device registration confirmation screen is displayed, select whether you register the approved device to the printer.
10. On the printer's control panel, select **Complete**.

For smart devices that have been connected to the printer before, select the network name (SSID) on the smart device's Wi-Fi screen to connect them again.

Related Information



- ➔ [“Connecting to Devices other than iOS and Android using Wi-Fi Direct” on page 106](#)
- ➔ [“Printing from Smart Devices” on page 162](#)

Connecting to Devices other than iOS and Android using Wi-Fi Direct

This method allows you to connect the printer directly to smart devices without a wireless router.

Note:

You only need to make these settings for the printer and the smart device that you want to connect to once. Unless you disable Wi-Fi Direct or restore the network settings to their defaults, you do not need to make these settings again.

1. Tap  |  on the home screen.
2. Tap **Wi-Fi Direct**.
3. Tap **Start Setup**.

Network Settings

4. Tap **Other OS Devices**.

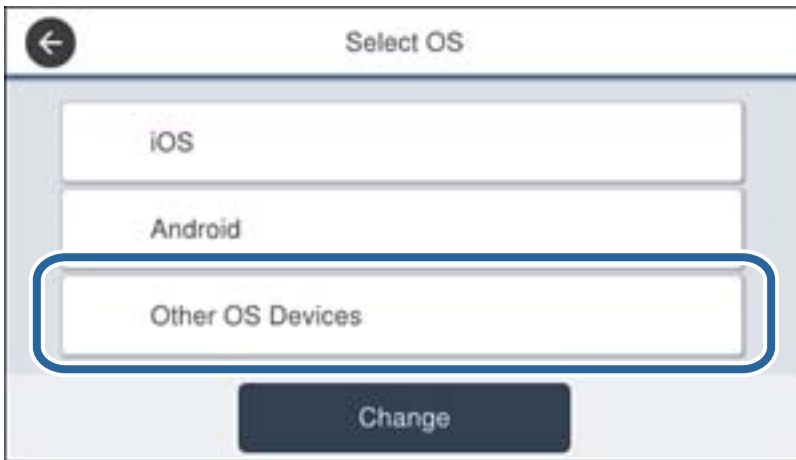

The Network Name(SSID) and Password for Wi-Fi Direct for the printer are displayed.

Network Settings

5. On the smart device's Wi-Fi screen, select the SSID shown on the printer's control panel, and then enter the password.



6. On the printer's control panel, select Next.

Network Settings

- On the smart device, start Epson iPrint.



- On the Epson iPrint screen, tap **Printer is not selected.**
- Select the printer that you want to connect to.



See the information displayed on the printer's control panel to select the printer.



- On the printer's control panel, select **Complete**.

For smart devices that have been connected to the printer before, select the network name (SSID) on the smart device's Wi-Fi screen to connect them again.

Related Information

➔ [“Printing from Smart Devices” on page 162](#)

Making Wi-Fi Settings from the Printer

You can make network settings from the printer's control panel in several ways. Choose the connection method that matches the environment and conditions that you are using.

If you know the information for the wireless router such as SSID and password, you can make settings manually.

If the wireless router supports WPS, you can make settings by using push button setup.

After connecting the printer to the network, connect to the printer from the device that you want to use (computer, smart device, tablet, and so on.)

Make advanced network settings to use a static IP address.

Related Information

- ➔ [“Making Wi-Fi Settings by Entering the SSID and Password” on page 110](#)
- ➔ [“Making Wi-Fi Settings by Push Button Setup \(WPS\)” on page 111](#)
- ➔ [“Making Wi-Fi Settings by PIN Code Setup \(WPS\)” on page 112](#)
- ➔ [“Making Advanced Network Settings” on page 113](#)



Making Wi-Fi Settings by Entering the SSID and Password

You can set up a Wi-Fi network by entering the information necessary to connect to a wireless router from the printer's control panel. To set up using this method, you need the SSID and password for a wireless router.

Note:

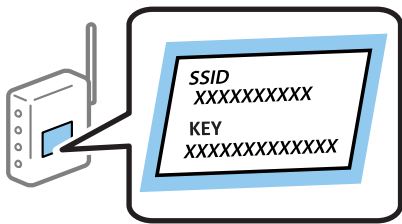
If you are using an wireless router with its default settings, the SSID and password are on the label. If you do not know the SSID and password, contact the person who set up the wireless router, or see the documentation provided with the wireless router.



1. Tap  |  on the home screen.
2. Select **Router**.
3. Tap **Start Setup**.

If the network connection is already set up, the connection details are displayed. Tap **Change to Wi-Fi connection**, or **Change Settings** to change the settings.

4. Select **Wi-Fi Setup Wizard**.

Network Settings

5. Select the SSID for the wireless router.

Note:

- If the SSID you want to connect to is not displayed on the printer's control panel, tap **Search Again** to update the list. If it is still not displayed, tap **Enter Manually**, and then enter the SSID directly.
- If you do not know the SSID, check if it is written on the label of the wireless router. If you are using the wireless router with its default settings, use the SSID written on the label.

6. Enter the password.

Note:

- The password is case-sensitive.
- If you do not know the password, check if the information is written on the label of the wireless router. On the label, the password may be written "Network Key", "Wireless Password", and so on. If you are using the wireless router with its default settings, use the password written on the label.

7. When you have setup finished, tap **Start Setup**.

8. Tap **OK** to finish.

Note:

If you fail to connect, load A4 size plain paper, and then tap **Print Check Report** to print a connection report.

9. Close the network connection settings screen.

Related Information

- ➔ ["Entering Characters" on page 24](#)
- ➔ ["Checking the Network Connection Status" on page 115](#)
- ➔ ["When You Cannot Make Network Settings" on page 263](#)

Making Wi-Fi Settings by Push Button Setup (WPS)

You can automatically set up a Wi-Fi network by pressing a button on the wireless router. If the following conditions are met, you can set up by using this method.

- The wireless router is compatible with WPS (Wi-Fi Protected Setup).
- The current Wi-Fi connection was established by pressing a button on the wireless router.

Note:

If you cannot find the button or you are setting up using the software, see the documentation provided with the wireless router.

1. Tap  |  on the home screen.

2. Select **Router**.

3. Tap **Start Setup**.

If the network connection is already set up, the connection details are displayed. Tap **Change to Wi-Fi connection**, or **Change Settings** to change the settings.

4. Select **Push Button Setup(WPS)**.

Network Settings

5. Hold down the [WPS] button on the wireless router until the security light flashes.

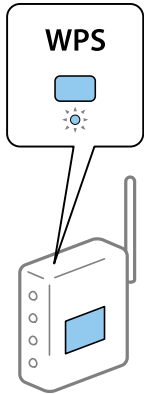

If you do not know where the [WPS] button is, or there are no buttons on the wireless router, see the documentation provided with your wireless router for details.

6. Tap **Start Setup**.

7. Close the screen.

The screen automatically closes after a specific length of time.

Note:

If connection fails, restart the wireless router, move it closer to the printer, and try again. If it still does not work, print a network connection report and check the solution.

8. Close the network connection settings screen.

Related Information

- ➔ [“Checking the Network Connection Status” on page 115](#)
- ➔ [“When You Cannot Make Network Settings” on page 263](#)

Making Wi-Fi Settings by PIN Code Setup (WPS)

You can automatically connect to an wireless router by using a PIN code. You can use this method to set up if an wireless router is capable of WPS (Wi-Fi Protected Setup). Use a computer to enter a PIN code into the wireless router.

1. Tap  |  on the home screen.

2. Select **Router**.

3. Tap **Start Setup**.

If the network connection is already set up, the connection details are displayed. Tap **Change to Wi-Fi connection.** or **Change Settings** to change the settings.

4. Select **Others > PIN Code Setup(WPS)**

Network Settings

5. Use your computer to enter the PIN code (an eight digit number) displayed on the printer's control panel into the wireless router within two minutes.

Note:

See the documentation provided with your wireless router for details on entering a PIN code.

6. Tap **Start Setup**.

7. Close the screen.

The screen automatically closes after a specific length of time if you do not select **Close**.

Note:

If connection fails, restart the wireless router, move it closer to the printer, and try again. If it still does not work, print a connection report and check the solution.

8. Close the network connection settings screen.

Related Information

- ➔ [“Checking the Network Connection Status” on page 115](#)
- ➔ [“When You Cannot Make Network Settings” on page 263](#)

Making Advanced Network Settings

You can change the network device name, TCP/IP setup, proxy server and so on. Check your network environment before making changes.

1. Select **Settings** on the home screen.
2. Select **General Settings > Network Settings > Advanced**.
3. Select the menu item for settings, and then select or specify the setting values.

Related Information

- ➔ [“Setting Items for Advanced Network Settings” on page 113](#)

Setting Items for Advanced Network Settings

Select the menu item for settings, and then select or specify the setting values.

Device Name

You can enter the following characters.

- Character limits: 2 to 15 (you must enter at least 2 characters)
- Usable characters: A to Z, a to z, 0 to 9, -.
- Characters you cannot use at the top: 0 to 9.
- Characters you cannot use at the bottom: -

Network Settings

- TCP/IP
 - Auto

Select when you are using an access point at home or you are allowing the IP address to be acquired automatically by DHCP.
 - Manual

Select when you do not want the printer's IP address to be changed. Enter the addresses for IP Address, Subnet Mask, and Default Gateway, and make DNS Server settings according to your network environment.
- Proxy Server
 - Do Not Use

Select when you are using the printer in a home network environment.
 - Use

Select when you are using a proxy server in your network environment and you want to set it to the printer. Enter the proxy server address and port number.
- Email Server
 - Server Settings

You can select the server from Off, POP before SMTP, or SMTP-AUTH.
 - Connection Check

You can check the connection for e-mail server. See *Administrator's Guide* if an error occurs when performing **Connection Check**.
- IPv6 Address
 - Enable

Select this when using an IPv6 address.
 - Disable

Select this when using an IPv4 address.
- MS Network Sharing
 - Enable

Use MS Network service.
 - Disable

Disables the MS Network service.
 - File Sharing

Enables or disables the file sharing function.
- Link Speed & Duplex

Select an appropriate Ethernet speed and duplex setting. If you select a setting other than Auto, make sure the setting corresponds to the settings on the hub you are using.

 - Auto
 - 10BASE-T Half Duplex
 - 10BASE-T Full Duplex
 - 100BASE-TX Half Duplex
 - 100BASE-TX Full Duplex

Network Settings

- Redirect HTTP to HTTPS
 - Enable
 - Enables the redirect function for HTTP to HTTPS.
 - Disable
 - Disables the redirect function for HTTP to HTTPS.
- Disable IPsec/IP Filtering
 - Disables the IPsec/IP filtering function if you cannot connect to the printer because of the security settings.
- Disable IEEE802.1X
 - Disables the IEEE802.1X function if you cannot connect to the printer because of the security settings.
- iBeacon Transmission
 - Enable
 - Enables the iBeacon transmission function.
 - Disable
 - Disables the iBeacon transmission function.

Checking the Network Connection Status

You can check the network connection status in the following way.

Network Icon

You can check the network connection status and strength of the radio wave using the network icon on the printer's home screen.



Related Information

➔ [“Icons displayed in the LCD Screen” on page 22](#)

Checking Detailed Network Information from the Control Panel

When your printer is connected to the network, you can also view other network-related information by selecting the network menus you want to check.

1. Select **Settings** on the home screen.

Network Settings

2. Select **General Settings > Network Settings > Network Status**.
3. To check the information, select the menus that you want to check.
 - Wired LAN/Wi-Fi Status**
Displays the network information (device name, connection, signal strength, and so on) for Ethernet or Wi-Fi connections.
 - Wi-Fi Direct Status**
Displays whether Wi-Fi Direct is enabled or disabled, and the SSID, password and so on for Wi-Fi Direct connections.
 - Email Server Status**
Displays the network information for email server.
 - Print Status Sheet**
Prints a network status sheet. The information for Ethernet, Wi-Fi, Wi-Fi Direct, and so on is printed on two or more pages.

Printing a Network Connection Report

You can print a network connection report to check the status between the printer and the wireless router.

1. Load papers.
2. Select **Settings** on the home screen.
3. Select **General Settings > Network Settings > Connection Check**.
The connection check starts.
4. Select **Print Check Report**.
5. Print the network connection report.
If an error has occurred, check the network connection report, and then follow the printed solutions.
6. Close the screen.

Related Information

➔ [“Messages and Solutions on the Network Connection Report” on page 117](#)

Network Settings

Messages and Solutions on the Network Connection Report

Check the messages and error codes on the network connection report, and then follow the solutions.

Check Network Connection

Check Result: FAIL

Error code: (E-2)

See the Network Status and check if the Network Name (SSID) is the SSID you want to connect.
If the SSID is correct, make sure to enter the correct password and try again.

If your problems persist, see your documentation for help and networking tips.

Checked Items

Wireless Network Name (SSID) Check	FAIL
Communication Mode Check	Unchecked
Security Mode Check	Unchecked
MAC Address Filtering Check	Unchecked
Security Key/Password Check	Unchecked
IP Address Check	Unchecked
Detailed IP Setup Check	Unchecked

Network Status

Printer Name	EPSON XXXXXX
Printer Model	XX-XXX Series
IP Address	169.254.137.8
Subnet Mask	255.255.0.0
Default Gateway	
Network Name (SSID)	EpsonNet
Security	None
Signal Strength	Poor
MAC Address	F8:D0:27:40:C0:AC

a. Error code

b. Messages on the Network Environment

Related Information

- ➔ “E-1” on page 118
- ➔ “E-2, E-3, E-7” on page 118
- ➔ “E-5” on page 119
- ➔ “E-6” on page 119
- ➔ “E-8” on page 119
- ➔ “E-9” on page 120
- ➔ “E-10” on page 120
- ➔ “E-11” on page 120
- ➔ “E-12” on page 121
- ➔ “E-13” on page 121
- ➔ “Message on the Network Environment” on page 122

Network Settings

E-1

Solutions:

- Make sure the Ethernet cable is securely connected to your printer and to your hub or other network device.
- Make sure your hub or other network device is turned on.
- If you want to connect the printer by Wi-Fi, make Wi-Fi settings for the printer again because it is disabled.

E-2, E-3, E-7

Solutions:

- Make sure your wireless router is turned on.
- Confirm that your computer or device is connected correctly to the wireless router.
- Turn off the wireless router. Wait for about 10 seconds, and then turn it on.
- Place the printer closer to your wireless router and remove any obstacles between them.
- If you have entered the SSID manually, check if it is correct. Check the SSID from the **Network Status** part on the network connection report.
- If an wireless router has multiple SSIDs, select the SSID that is displayed. When the SSID is using a non-compliant frequency, the printer does not display them.
- If you are using push button setup to establish a network connection, make sure your wireless router supports WPS. You cannot use push button setup if your wireless router does not support WPS.
- Make sure your SSID uses only ASCII characters (alphanumeric characters and symbols). The printer cannot display an SSID that contains non-ASCII characters.
- Make sure you know your SSID and password before connecting to the wireless router. If you are using a wireless router with its default settings, the SSID and password are located on a label on the wireless router. If you do not know your SSID and password, contact the person who set up the wireless router, or see the documentation provided with the wireless router.
- If you are connecting to an SSID generated from a tethering smart device, check for the SSID and password in the documentation provided with the smart device.
- If your Wi-Fi connection suddenly disconnects, check for the conditions below. If any of these conditions are applicable, reset your network settings by downloading and running the software from the following website.
<http://epson.sn> > **Setup**
 - Another smart device was added to the network using push button setup.
 - The Wi-Fi network was set up using any method other than push button setup.

Related Information

- ➔ [“Connecting to a Computer” on page 100](#)
- ➔ [“Making Wi-Fi Settings from the Printer” on page 110](#)

Network Settings

E-5

Solutions:

Make sure the wireless router's security type is set to one of the following. If it is not, change the security type on the wireless router, and then reset the printer's network settings.

- WEP-64 bit (40 bit)
- WEP-128 bit (104 bit)
- WPA PSK (TKIP/AES)*
- WPA2 PSK (TKIP/AES)*
- WPA (TKIP/AES)
- WPA2 (TKIP/AES)

* WPA PSK is also known as WPA Personal. WPA2 PSK is also known as WPA2 Personal.

E-6

Solutions:

- Check if MAC address filtering is disabled. If it is enabled, register the printer's MAC address so that it is not filtered. See the documentation provided with the wireless router for details. You can check the printer's MAC address from the **Network Status** part on the network connection report.
- If your wireless router is using shared authentication with WEP security, make sure the authentication key and index are correct.
- If the number of connectable devices on the wireless router is less than the number of network devices that you want to connect, make settings on the wireless router to increase the number of connectable devices. See the documentation provided with the wireless router to make settings.

Related Information

- ➔ [“Making Advanced Network Settings” on page 113](#)
- ➔ [“Printing a Network Status Sheet” on page 122](#)

E-8

Solutions:

- Enable DHCP on the wireless router if the printer's Obtain IP Address setting is set to **Auto**.
- If the printer's Obtain IP Address setting is set to Manual, the IP address you manually set is invalid due to out of range (for example: 0.0.0.0). Set a valid IP address from the printer's control panel or by using Web Config.

Related Information

- ➔ [“Making Advanced Network Settings” on page 113](#)

Network Settings

E-9

Solutions:

Check the following.

- Devices are turned on.
- You can access the Internet and other computers or network devices on the same network from the devices you want to connect to the printer.

If still does not connect your printer and network devices after confirming the above, turn off the wireless router. Wait for about 10 seconds, and then turn it on. Then reset your network settings by downloading and running the installer from the following website.

<http://epson.sn> > Setup

Related Information

➔ [“Connecting to a Computer” on page 100](#)

E-10

Solutions:

Check the following.

- Other devices on the network are turned on.
- Network addresses (IP address, subnet mask, and default gateway) are correct if you have set the printer's Obtain IP Address to Manual.

Reset the network address if they are incorrect. You can check the IP address, subnet mask, and default gateway from the **Network Status** part on the network connection report.

If DHCP is enabled, change the printer's Obtain IP Address setting to **Auto**. If you want to set the IP address manually, check the printer's IP address from the **Network Status** part on the network connection report, and then select Manual on the network settings screen. Set the subnet mask to [255.255.255.0].

If still does not connect your printer and network devices, turn off the wireless router. Wait for about 10 seconds, and then turn it on.

Related Information

➔ [“Making Advanced Network Settings” on page 113](#)

E-11

Solutions:

Check the following.

- The default gateway address is correct if you set the printer's TCP/IP Setup setting to Manual.
- The device that is set as the default gateway is turned on.

Set the correct default gateway address. You can check the default gateway address from the **Network Status** part on the network connection report.

Network Settings

Related Information

- ➔ [“Making Advanced Network Settings” on page 113](#)

E-12

Solutions:

Check the following.

- Other devices on the network are turned on.
- The network addresses (IP address, subnet mask, and default gateway) are correct if you are entering them manually.
- The network addresses for other devices (subnet mask and default gateway) are the same.
- The IP address does not conflict with other devices.

If still does not connect your printer and network devices after confirming the above, try the following.

- Turn off the wireless router. Wait for about 10 seconds, and then turn it on.
- Make network settings again using the installer. You can run it from the following website.
<http://epson.sn> > **Setup**
- You can register several passwords on a wireless router that uses WEP security type. If several passwords are registered, check if the first registered password is set on the printer.

Related Information

- ➔ [“Making Advanced Network Settings” on page 113](#)
- ➔ [“Connecting to a Computer” on page 100](#)

E-13

Solutions:

Check the following.

- Network devices such as a wireless router, hub, and router are turned on.
- The TCP/IP Setup for network devices has not been set up manually. (If the printer's TCP/IP Setup is set automatically while the TCP/IP Setup for other network devices is performed manually, the printer's network may differ from the network for other devices.)

If it still does not work after checking the above, try the following.

- Turn off the wireless router. Wait for about 10 seconds, and then turn it on.
- Make network settings on the computer that is on the same network as the printer using the installer. You can run it from the following website.
<http://epson.sn> > **Setup**
- You can register several passwords on a wireless router that uses the WEP security type. If several passwords are registered, check if the first registered password is set on the printer.

Network Settings

Related Information

- ➔ [“Making Advanced Network Settings” on page 113](#)
- ➔ [“Connecting to a Computer” on page 100](#)

Message on the Network Environment

Message	Solution
*Multiple network names (SSID) that match your entered network name (SSID) have been detected. Confirm network name (SSID).	The same SSID may be set on several wireless router. Check the settings on the wireless router, and change the SSID.
The Wi-Fi environment needs to be improved. Turn the wireless router off and then turn it on. If the connection does not improve, see the documentation for the wireless router.	After moving the printer closer to the wireless router and removing any obstacles between them, turn off the wireless router. Wait for about 10 seconds, and then turn it on. If it still does not connect, see the documentation supplied with the wireless router.
*No more devices can be connected. Disconnect one of the connected devices if you want to add another one.	Computer and smart devices that can be connected simultaneously are connected in full in the Wi-Fi Direct (Simple AP) connection. To add another computer or smart device, disconnect one of the connected devices first. You can confirm the number of wireless devices which can be connected simultaneously and the number of connected devices by checking the network status sheet or the printer's control panel.
The same SSID as Wi-Fi Direct exists in the environment. Change the Wi-Fi Direct SSID if you cannot connect a smart device to the printer.	On the printer's control panel, go to Wi-Fi Direct Setup screen and select the menu to change the setting. You can change the network name following after DIRECT-XX-. Enter within 32 characters.

Printing a Network Status Sheet

You can check the detailed network information by printing it.

1. Load papers.
2. Select **Settings** on the home screen.
3. Select **General Settings > Network Settings > Network Status**.
4. Select **Print Status Sheet**.
5. Check the message, and then print the network status sheet.
6. Close the screen.

The screen automatically closes after a specific length of time.

Replacing or Adding New Wireless Routers

If the SSID changes due to the replacement of a wireless router, or a wireless router is added and a new network environment is established, re-set the Wi-Fi settings.

Related Information

➔ [“Changing the Connection Method to a Computer” on page 123](#)

Changing the Connection Method to a Computer

Using the installer and re-set up in a different connection method.

- Setting up from the website

Access the following website, and then enter the product name. Go to **Setup**, and then start setting up.

<http://epson.sn>

- Setting up using the software disc (only for the models that come with a software disc and users with Windows computers with disc drives.)

Insert the software disc into the computer, and then follow the on-screen instructions.

Selecting Change the Connection Methods

Follow the on-screen instructions until the following screen is displayed.

Select **Set up Printer connection again (for new network router or changing USB to network, etc.)** on the Install Software screen, and then click **Next**.

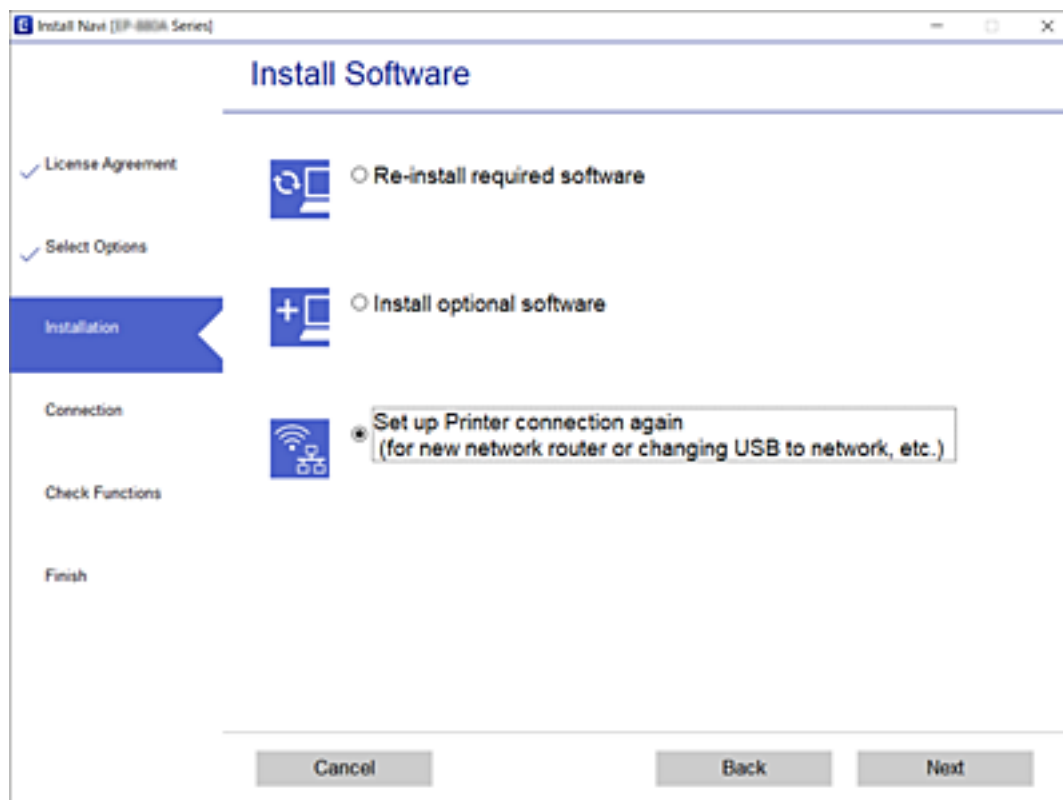



Changing the Network Connection to Ethernet from the Control Panel

Follow the steps below to change the network connection to Ethernet from Wi-Fi using the control panel.

1. Select **Settings** on the home screen.
2. Select **General Settings** > **Network Settings** > **Wired LAN Setup**.
3. Tap **Start Setup**.
4. Check the message, and then close the screen.
The screen automatically closes after a specific length of time.
5. Connect the printer to a router using an Ethernet cable.

Changing the Wi-Fi Direct (Simple AP) Settings

When Wi-Fi Direct (simple AP) connection is enabled, you can change the settings from  |  > **Wi-Fi Direct** > **Start Setup** > **Change**, and then the following menu items are displayed.

Changing network name (SSID)

Change the Wi-Fi Direct (simple AP) network name (SSID) used for connecting to the printer to your arbitrary name. You can set the network name (SSID) in ASCII characters that is displayed on the software keyboard on the control panel.

When changing the network name (SSID), all connected devices are disconnected. Use the new network name (SSID) if you want to re-connect the device.

Changing password

Change the Wi-Fi Direct (simple AP) password for connecting to the printer to your arbitrary value. You can set the password in ASCII characters that is displayed on the software keyboard on the control panel.

When changing the password, all connected devices are disconnected. Use the new password if you want to re-connect the device.

Disabling Wi-Fi Direct (simple AP)

Disable Wi-Fi Direct (simple AP) settings of the printer. When disabling it, all devices connected to the printer in Wi-Fi Direct (Simple AP) connection are disconnected.

Restoring Wi-Fi Direct (simple AP) settings

Restore all Wi-Fi Direct (simple AP) settings to their defaults.

The Wi-Fi Direct (simple AP) connection information of the smart device saved to the printer is deleted.

Network Settings



Note:

You can also set up from the **Network** tab > **Wi-Fi Direct** on Web Config for the following settings.

- Enabling or disabling Wi-Fi Direct (simple AP)
- Changing network name (SSID)
- Changing password
- Restoring the Wi-Fi Direct (simple AP) settings

Disabling Wi-Fi from the Control Panel

When Wi-Fi is disabled, the Wi-Fi connection is disconnected.

1. Tap  on the home screen.
2. Select **Router**.
The network status is displayed.
3. Tap **Change Settings**.
4. Select **Others** > **Disable Wi-Fi**.
5. Check the message, and then start setup.
6. When a completion message is displayed, close the screen.
The screen automatically closes after a specific length of time.
7. Close the Network Connection Settings screen.
8. Press the  button.

Disconnecting Wi-Fi Direct (Simple AP) Connection from the Control Panel

Note:

When Wi-Fi Direct (Simple AP) connection disabled, all computers and smart devices connected to the printer in Wi-Fi Direct (Simple AP) connection are disconnected. If you want to disconnect a specific device, disconnect from the device instead of the printer.

1. Tap  on the home screen.
2. Select **Wi-Fi Direct**.
The Wi-Fi Direct information is displayed.
3. Tap **Start Setup**.
4. Tap **Change**.

Network Settings

5. Select **Disable Wi-Fi Direct**.
6. Tap the **Disable the settings**.
7. When a completion message is displayed, close the screen.
The screen automatically closes after a specific length of time.
8. Close the **Network Connection Settings** screen.

Restoring the Network Settings from the Control Panel

You can restore all network settings to their defaults.

1. Select **Settings** on the home screen.
2. Select **General Settings >System Administration >Restore Default Settings > Network Settings**.
3. Check the message, and then select **Yes**.
4. When a completion message is displayed, close the screen.
The screen automatically closes after a specific length of time.

Printing

Printing from the Printer Driver on Windows

If you cannot change some of the printer driver settings, they may have been restricted by the administrator. Contact your printer administrator for assistance.

Accessing the Printer Driver

When accessing the printer driver from the computer's control panel, the settings are applied to all of the applications.

Accessing the printer driver from the control panel

Windows 10/Windows Server 2016

Click on the start button, and then select **Windows System > Control Panel > View devices and printers in Hardware and Sound**. Right-click on your printer, or press and hold it and then select **Printing preferences**.

Windows 8.1/Windows 8/Windows Server 2012 R2/Windows Server 2012

Select **Desktop > Settings > Control Panel > View devices and printers in Hardware and Sound**. Right-click on your printer, or press and hold it and then select **Printing preferences**.

Windows 7/Windows Server 2008 R2

Click the start button, and select **Control Panel > View devices and printers in Hardware and Sound**. Right-click on your printer and select **Printing preferences**.

Windows Vista/Windows Server 2008

Click the start button, and select **Control Panel > Printers in Hardware and Sound**. Right-click on your printer and select **Select printing preferences**.

Windows XP/Windows Server 2003 R2/Windows Server 2003

Click the start button, and select **Control Panel > Printers and Other Hardware > Printers and Faxes**. Right-click on your printer and select **Printing preferences**.

Accessing the printer driver from the printer icon on the task bar

The printer icon on the desktop task bar is a shortcut icon allowing you to quickly access the printer driver.

If you click the printer icon and select **Printer Settings**, you can access the same printer settings window as the one displayed from the control panel. If you double-click this icon, you can check the status of the printer.

Note:

*If the printer icon is not displayed on the task bar, access the printer driver window, click **Monitoring Preferences** on the **Maintenance** tab, and then select **Register the shortcut icon to the taskbar**.*

Printing Basics

Note:

Operations may differ depending on the application. See the application's help for details.

Printing

1. Open the file you want to print.
Load paper in the printer if it has not already been loaded.
2. Select **Print** or **Page Setup** from the **File** menu.
3. Select your printer.
4. Select **Preferences** or **Properties** to access the printer driver window.

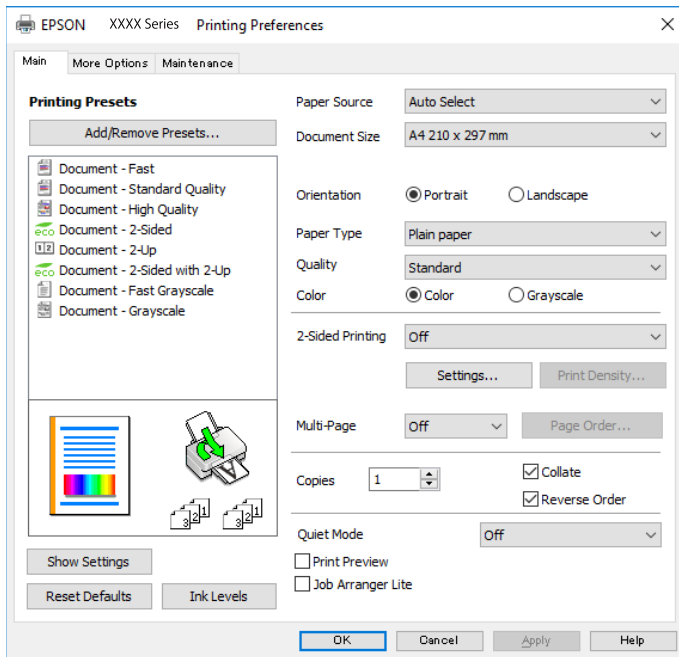

5. Change the settings as necessary.
See the menu options for the printer driver for details.

Note:

- You can also see the online help for explanations of the setting items. Right-clicking an item displays **Help**.
- When you select **Print Preview**, you can see a preview of your document before printing.

6. Click **OK** to close the printer driver window.
7. Click **Print**.

Note:

When you select **Print Preview**, a preview window is displayed. To change the settings, click **Cancel**, and then repeat the procedure from step 2.

Related Information

- ➔ [“Available Paper and Capacities” on page 27](#)
- ➔ [“Loading Paper in the Paper Cassette” on page 32](#)
- ➔ [“Loading Paper in the Rear Paper Feed” on page 34](#)
- ➔ [“List of Paper Type” on page 38](#)
- ➔ [“Main Tab” on page 144](#)

Printing

Printing on 2-Sides

You can print on both sides of the paper. You can also print a booklet that can be created by re-ordering the pages and folding the printout.

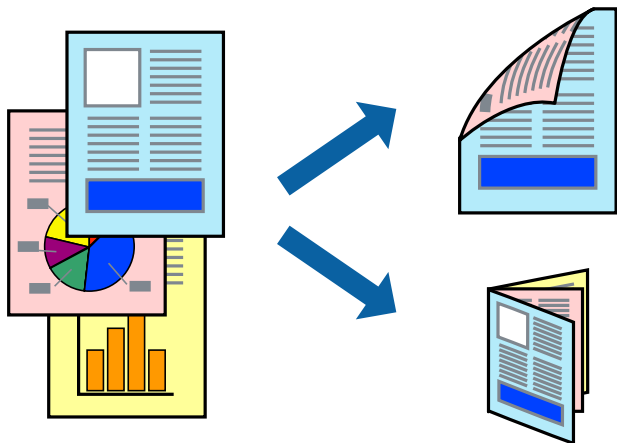

Note:

- You can use automatic and manual 2-sided printing. During manual 2-sided printing, flip the paper over to print on the other side when the printer has finished printing the first side.
- If you do not use paper that is suitable for 2-sided printing, the print quality may decline and paper jams may occur.
- Depending on the paper and the data, ink may bleed through to the other side of the paper.

Related Information

➔ [“Available Paper and Capacities” on page 27](#)

Print Settings

Manual 2-sided printing is available when EPSON Status Monitor 3 is enabled. However, it may not be available when the printer is accessed over a network or is used as a shared printer.

Note:

To enable EPSON Status Monitor 3, click **Extended Settings** on the **Maintenance** tab, and then select **Enable EPSON Status Monitor 3**.

1. On the printer driver's **Main** tab, select an option from **2-Sided Printing**.
2. Click **Settings**, make the appropriate settings, and then click **OK**.

Make settings for **Print Density** if necessary. This setting is not available when you select manual 2-sided printing.

Note:

- To print a folded booklet, select **Booklet**.
- When setting **Print Density**, you can adjust print density according to the document type.
- Printing may be slow depending on the combination of options selected for **Select Document Type** in the **Print Density Adjustment** window and for **Quality** on the **Main** tab.

Printing

3. Click **Print**.

For manual 2-sided printing, when the first side has finished printing, a pop-up window is displayed on the computer. Follow the on-screen instructions.

Related Information

- ➔ [“Printing Basics” on page 127](#)
- ➔ [“Main Tab” on page 144](#)

Printing Several Pages on One Sheet

You can print two or four pages of data on a single sheet of paper.

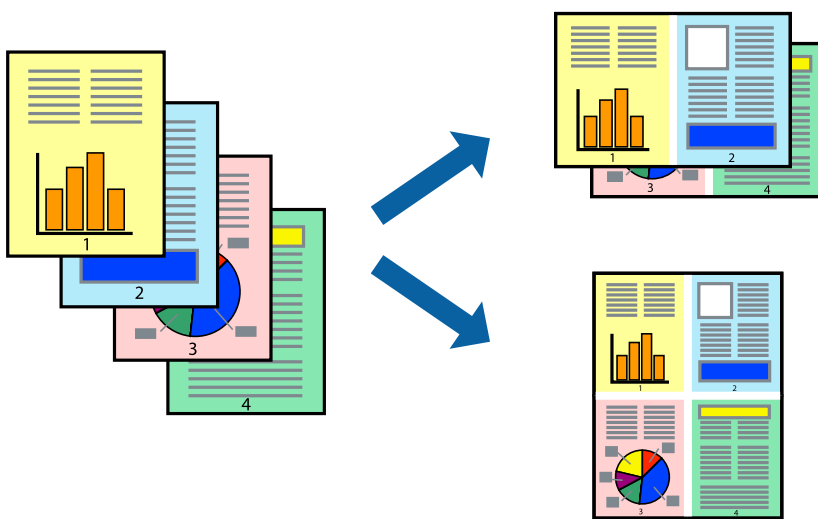

Print Settings

On the printer driver's **Main** tab, select **2-Up** or **4-Up** as the **Multi-Page** setting.

Related Information

- ➔ [“Printing Basics” on page 127](#)
- ➔ [“Main Tab” on page 144](#)

Printing

Printing and Stacking in Page Order (Reverse Order Printing)

You can print from the last page so that the documents are stacked in page order.

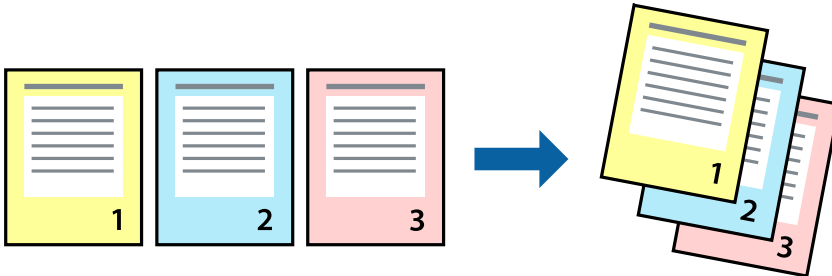

Print Settings

On the printer driver's **Main** tab, select **Reverse Order**.

Related Information

- ➔ [“Printing Basics” on page 127](#)
- ➔ [“Main Tab” on page 144](#)

Printing a Reduced or Enlarged Document

You can reduce or enlarge the size of a document by a specific percentage or to fit the paper size you loaded in the printer.



Print Settings

On the printer driver's **More Options** tab, select the document size from the **Document Size** setting. Select the paper size you want to print on from the **Output Paper** setting. Select **Reduce/Enlarge Document**, and then select **Fit to Page** or **Zoom to**. When you select **Zoom to**, enter a percentage.

Select **Center** to print the images in the center of the page.

Printing

Related Information

- ➔ [“Printing Basics” on page 127](#)
- ➔ [“More Options Tab” on page 145](#)

Printing One Image on Multiple Sheets for Enlargement (Creating a Poster)

This feature allows you to print one image on multiple sheets of paper. You can create a larger poster by taping them together.

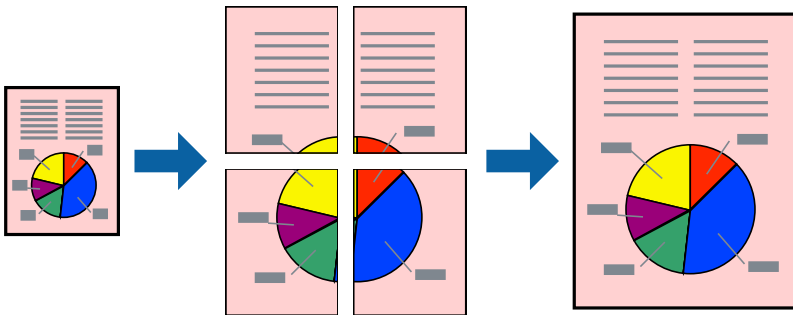

Print Settings

On the printer driver's **Main** tab, select **2x1 Poster**, **2x2 Poster**, **3x3 Poster**, or **4x4 Poster** as the **Multi-Page** setting. If you click **Settings**, you can select the panels that you do not want to print. You can also select the cutting guide options.

Related Information

- ➔ [“Printing Basics” on page 127](#)
- ➔ [“Main Tab” on page 144](#)

Making Posters Using Overlapping Alignment Marks

Here is an example of how to make a poster when **2x2 Poster** is selected, and **Overlapping Alignment Marks** is selected in **Print Cutting Guides**.

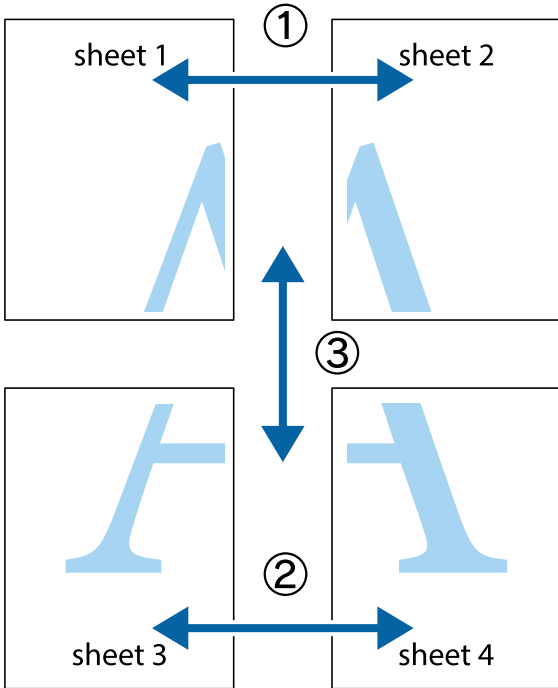

1. Prepare Sheet 1 and Sheet 2. Cut off the margins of Sheet 1 along the vertical blue line through the center of the top and bottom cross marks.

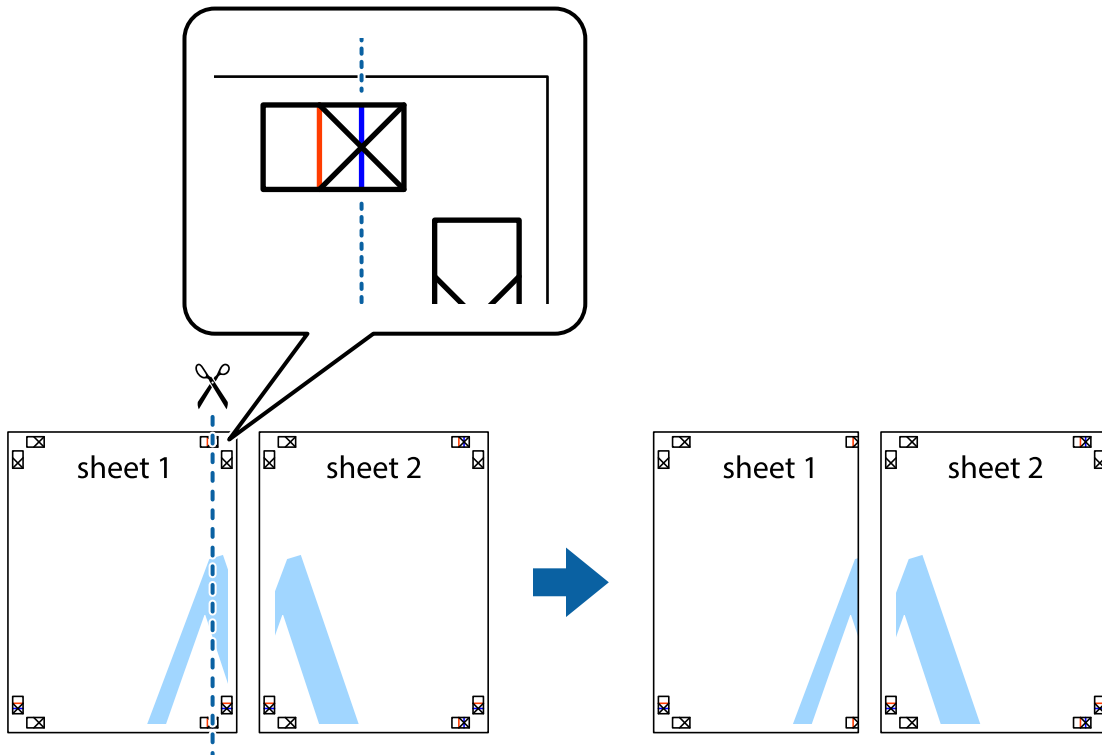

Printing

2. Place the edge of Sheet 1 on top of Sheet 2 and align the cross marks, then temporarily tape the two sheets together from the back.

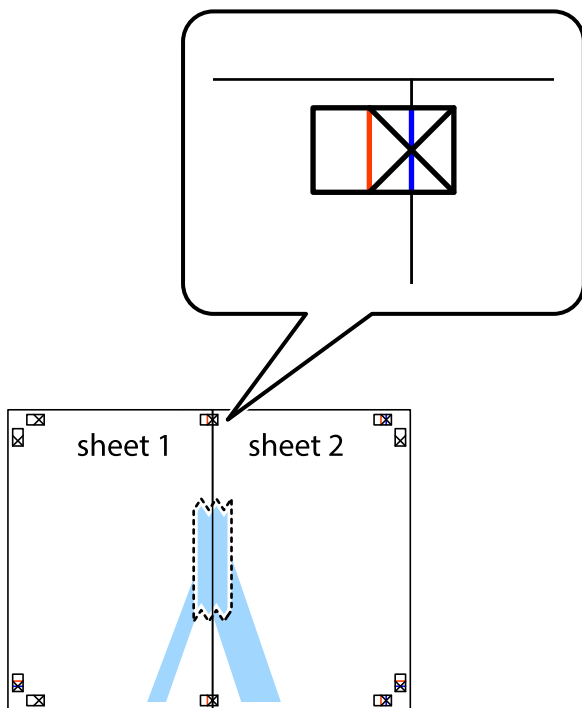

3. Cut the taped sheets in two along the vertical red line through the alignment markers (this time, the line to the left of the cross marks).

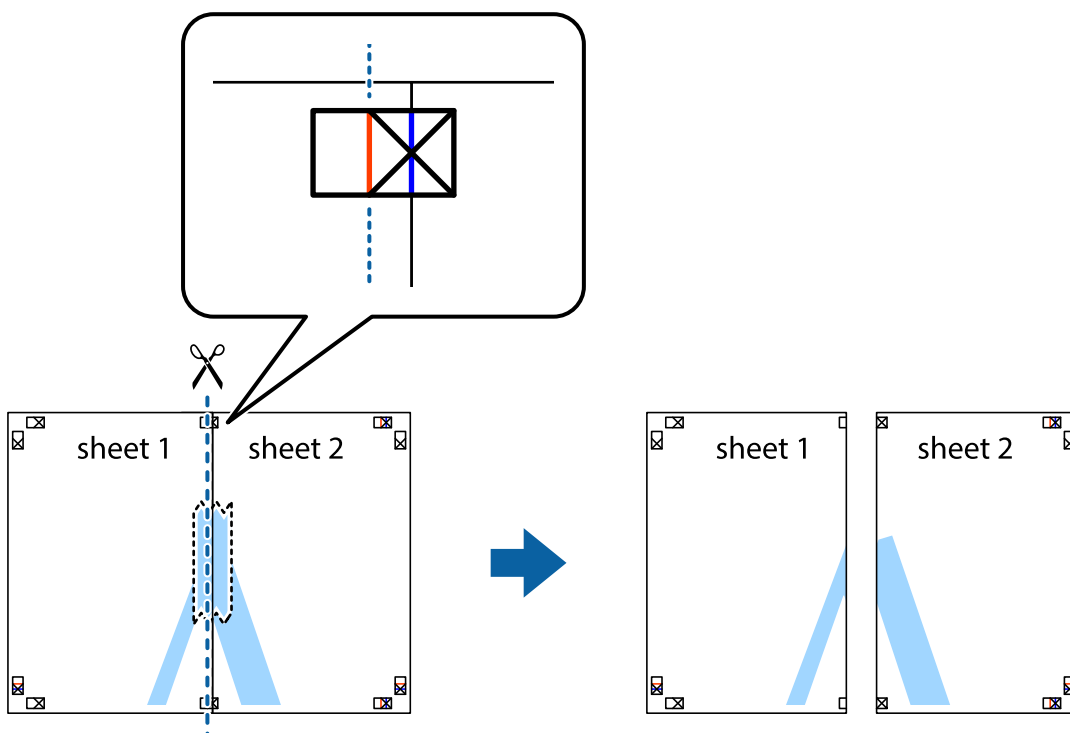

Printing

4. Tape the sheets together from the back.



5. Repeat steps 1 to 4 to tape Sheet 3 and Sheet 4 together.
6. Cut off the margins of Sheet 1 and Sheet 2 along the horizontal blue line through the center of the left and right side cross marks.

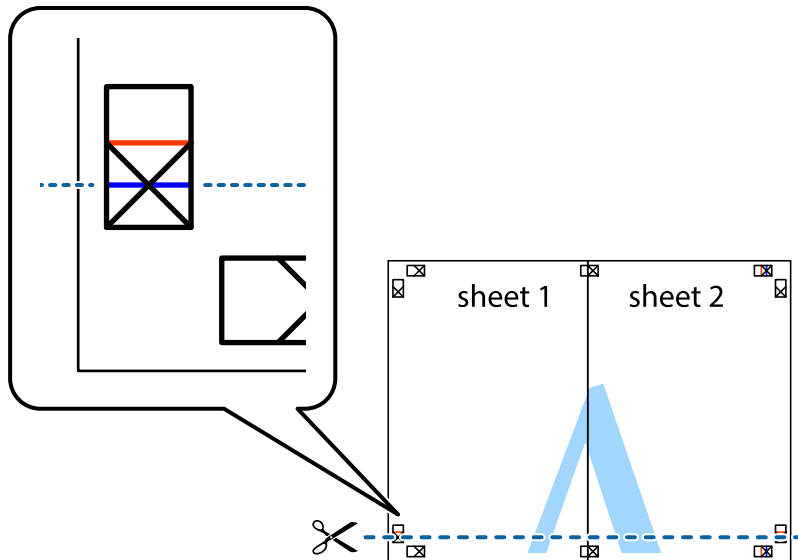

Printing

7. Place the edge of Sheet 1 and Sheet 2 on top of Sheet 3 and Sheet 4 and align the cross marks, and then temporarily tape them together from the back.

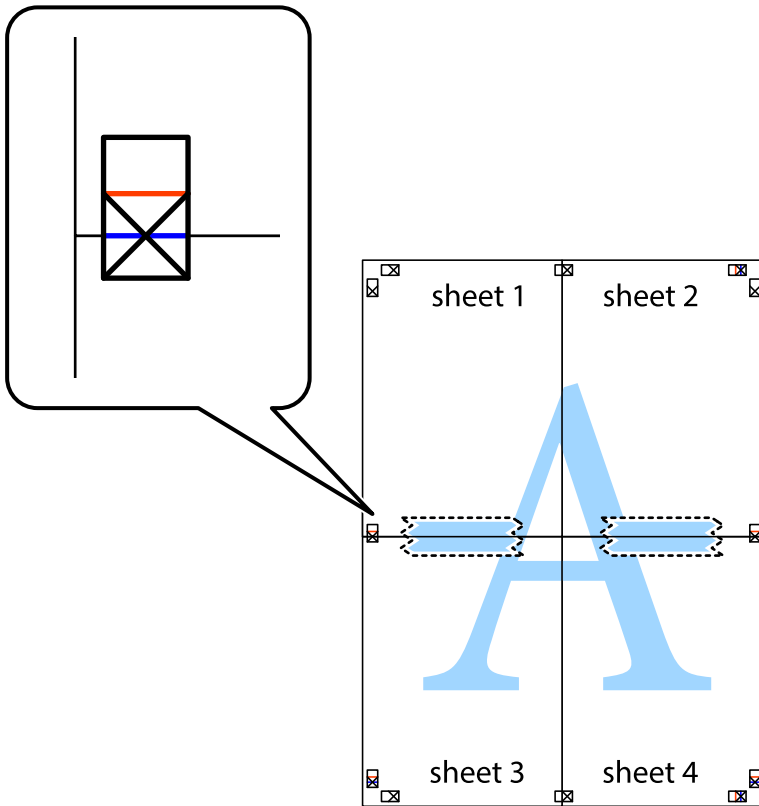

Printing

- Cut the taped sheets in two along the horizontal red line through the alignment markers (this time, the line above the cross marks).



- Tape the sheets together from the back.



Printing

10. Cut off the remaining margins along the outer guide.

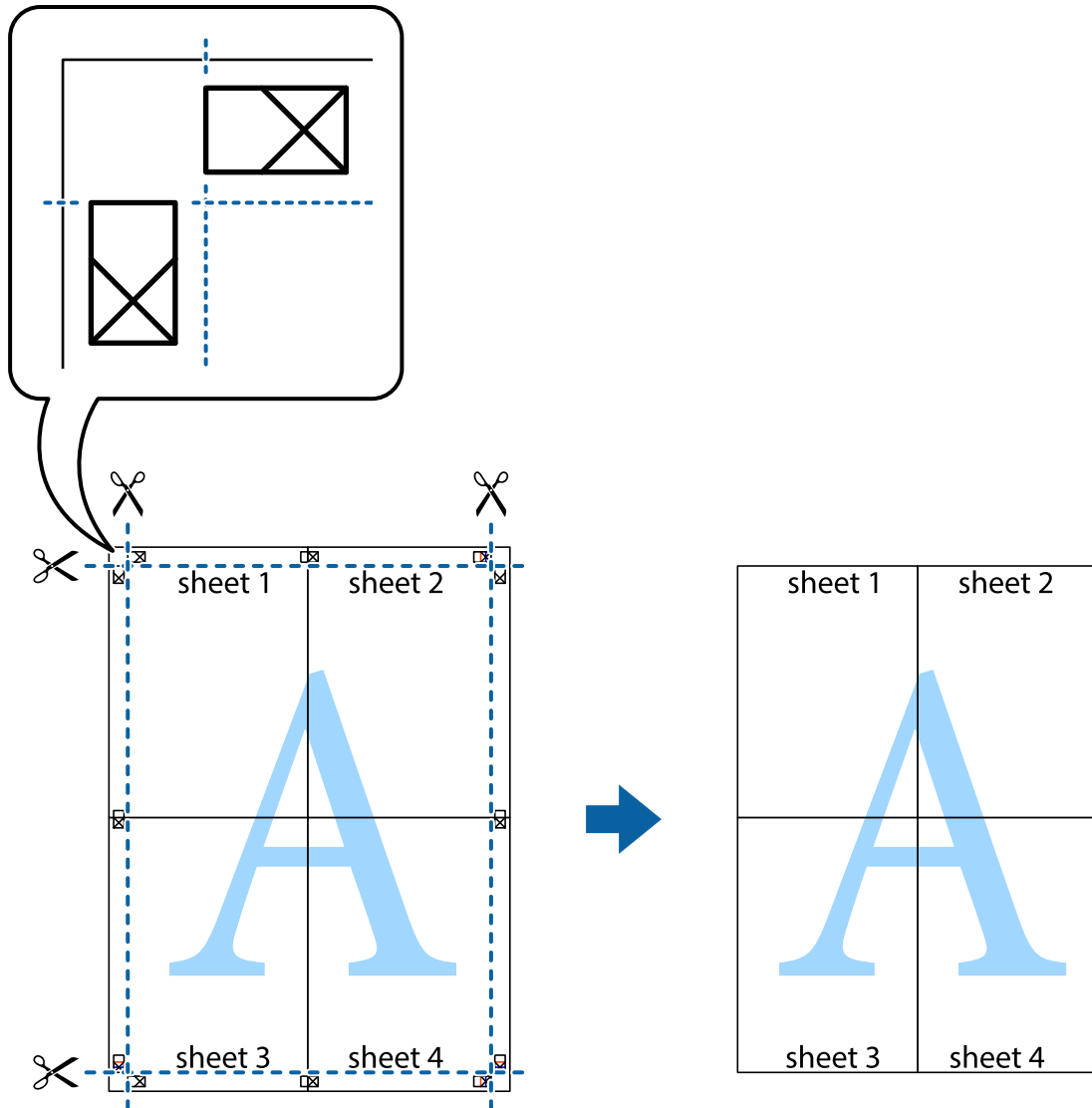

Printing with a Header and Footer

You can print information such as a user name and printing date in headers or footers.

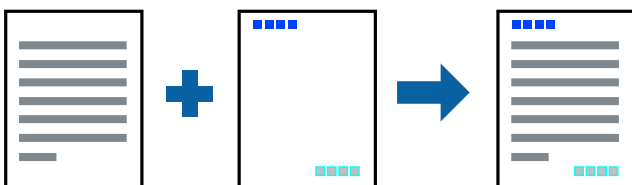

Print Settings

On the printer driver's **More Options** tab, click **Watermark Features**, and then select **Header/Footer**. Click **Settings**, and then select the items you want to print.

Printing

Related Information

- ➔ [“Printing Basics” on page 127](#)
- ➔ [“More Options Tab” on page 145](#)

Printing a Watermark

You can print a watermark such as "Confidential" or an anti-copy pattern on your printouts. If you print with an anti-copy pattern, the hidden letters appear when photocopied in order to distinguish the original from the copies.



Anti-Copy Pattern is available under the following conditions:

- Paper: Plain paper, Copy paper, Letterhead, Recycled paper, Colored paper, Preprinted paper, or High quality plain paper
- Quality: Standard
- Automatic 2-sided printing: Not selected
- Color Correction: Automatic

Note:

You can also add your own watermark or anti-copy pattern.

Print Settings

On the printer driver's **More Options** tab, click **Watermark Features**, and then select Anti-Copy Pattern or Watermark. Click **Settings** to change details such as the size, density, or position of the pattern or the mark.

Related Information

- ➔ [“Printing Basics” on page 127](#)
- ➔ [“More Options Tab” on page 145](#)

Printing

Printing Password-Protected Files

You can set a password for a print job so that it starts printing only after entering the password on the printer's control panel.

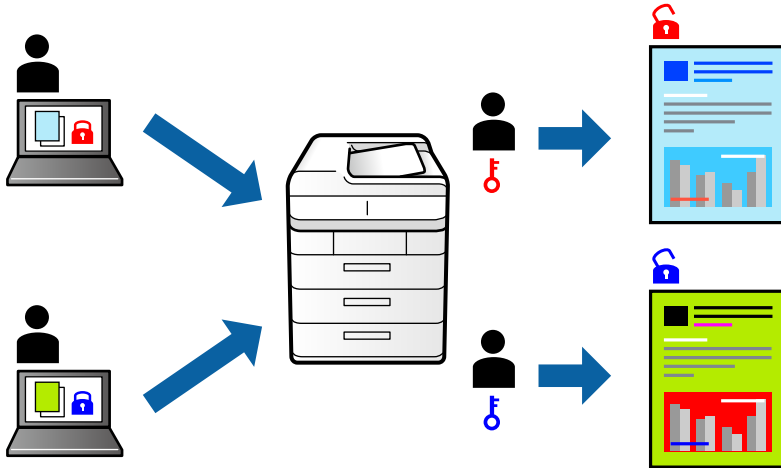

Print Settings

On the printer driver's **More Options** tab, select **Confidential Job**, and then enter a password.

To print the job, select **Confidential Job** on the home screen of the printer's control panel. Select the job you want to print, and then enter the password.

Related Information

- ➔ [“Printing Basics” on page 127](#)
- ➔ [“More Options Tab” on page 145](#)

Printing Multiple Files Together

Job Arranger Lite allows you to combine several files created by different applications and print them as a single print job. You can specify the print settings for combined files, such as multi-page layout, and 2-sided printing.

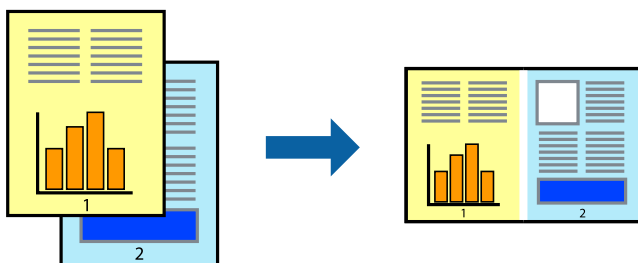

Print Settings

On the printer driver's **Main** tab, select **Job Arranger Lite**. When you start printing, the Job Arranger Lite window is displayed. With the Job Arranger Lite window opened, open the file that you want to combine with the current file, and then repeat the above steps.

Printing

When you select a print job added to Print Project in the Job Arranger Lite window, you can edit the page layout.

Click **Print** from the **File** menu to start printing.

Note:

If you close the Job Arranger Lite window before adding all the print data to the Print Project, the print job you are currently working on is canceled. Click **Save** from the **File** menu to save the current job. The extension of the saved files is ".ecl".

To open a Print Project, click **Job Arranger Lite** on the printer driver's **Maintenance** tab to open the Job Arranger Lite window. Next, select **Open** from the **File** menu to select the file.

Related Information

➔ ["Printing Basics" on page 127](#)

➔ ["Main Tab" on page 144](#)

Printing Using the Color Universal Print Feature

You can enhance the visibility of texts and images in printouts.

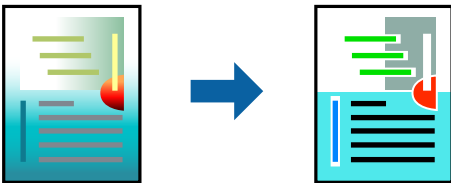

Color Universal Print is only available when the following settings are selected.

- Paper Type: Plain paper, Copy paper, Letterhead, Recycled paper, Colored paper, Preprinted paper, High quality plain paper
- Quality: **Standard** or a higher quality
- Print Color: **Color**
- Applications: Microsoft® Office 2007 or later
- Text Size: 96 pts or smaller

Print Settings

On the printer driver's **More Options** tab, click **Image Options** in the **Color Correction** setting. Select an option from the **Color Universal Print** setting. Click **Enhancement Options** to make further settings.

Note:

- Certain characters may be altered by patterns, such as "+" appearing as "±".
- Application-specific patterns and underlines may alter content printed using these settings.
- Print quality may decrease in photos and other images when using Color Universal Print settings.
- Printing is slower when using Color Universal Print settings.

Related Information

➔ ["Printing Basics" on page 127](#)

➔ ["More Options Tab" on page 145](#)

Adjusting the Print Color

You can adjust the colors used in the print job.

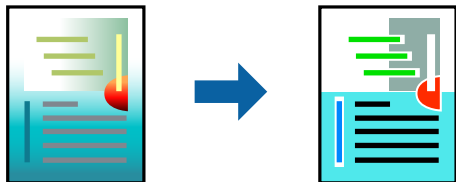

Note:

These adjustments are not applied to the original data.

Print Settings

On the printer driver's **More Options** tab, select **Custom** as the **Color Correction** setting. Click **Advanced** to open the **Color Correction** window, and then select the method of color correction.

Note:

- Automatic** is selected as default on the **More Options** tab. With this setting, the colors are automatically adjusted to match the paper type and print quality settings.
- PhotoEnhance** on the **Color Correction** window adjusts the color by analyzing the location of the subject. Therefore, if you have changed the location of the subject by reducing, enlarging, cropping, or rotating the image, the color may change unexpectedly. If the image is out of focus, the tone may be unnatural. If the color is changed or becomes unnatural, print in a mode other than **PhotoEnhance**.

Related Information

- ➔ [“Printing Basics” on page 127](#)
- ➔ [“More Options Tab” on page 145](#)

Printing to Emphasize Thin Lines

You can thicken thin lines that are too thin to print.

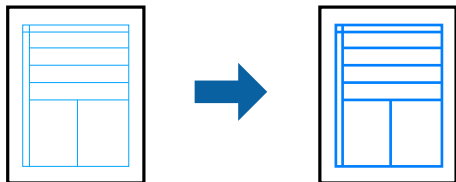

Print Settings

On the printer driver's **More Options** tab, click **Image Options** in the **Color Correction** setting. Select **Emphasize Thin Lines**.

Related Information

- ➔ [“Printing Basics” on page 127](#)

Printing

➔ [“More Options Tab” on page 145](#)

Printing Clear Bar Codes

You can print a bar code clearly and make it easy to scan. Only enable this feature if the bar code you printed cannot be scanned.

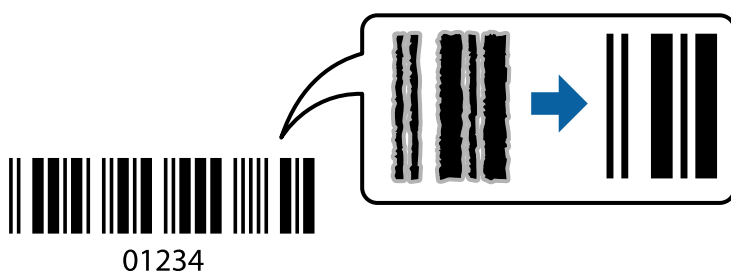

You can use this feature under the following conditions.

- Paper: Plain paper, Copy paper, Letterhead, Recycled paper, Colored paper, Preprinted paper, High quality plain paper, Thick paper with a thickness of 91 to 256g/m², Epson Matte Paper-Heavyweight, Epson Double-Sided Matte Paper, or Envelope
- Quality: **Standard**, **High** (not available for paper with a thickness of 161 to 256 g/m², Epson Matte Paper-Heavyweight, and Epson Double-Sided Matte Paper)

Note:

Deblurring may not always be possible depending on the circumstances.

Print Settings

On the printer driver's **Maintenance** tab, click **Extended Settings**, and then select **Barcode mode**.

Related Information

- ➔ [“Printing Basics” on page 127](#)
- ➔ [“Maintenance Tab” on page 145](#)

Canceling Printing

You can cancel a print job from the computer. However, you cannot cancel a print job from the computer once it has been completely sent to the printer. In this case, cancel the print job by using the printer's control panel.

Canceling

On your computer, right-click on your printer in **Devices and Printers**, **Printer**, or in **Printers and Faxes**. Click **See what's printing**, right-click on the job you want to cancel, and then select **Cancel**.

Printing

Menu Options for the Printer Driver

Open the print window in an application, select the printer, and then access the printer driver window.

Note:

Menus vary depending on the option you selected.

Main Tab

Printing Presets	Add/Remove Presets	You can add or remove your own presets for frequently used print settings. Select the preset you want to use from the list.
Show Settings	Displays a list of items currently set on the Main and More Options tabs.	
Reset Defaults	Return all settings to their factory default values. The settings on the More Options tab are also reset to their defaults.	
Ink Levels	Displays the approximate ink levels.	
Paper Source	Select the paper source from which the paper is fed. Select Auto Select to automatically select the paper source selected in Paper Setting on the printer.	
Document Size	Select the paper size on which you want to print. If you select User-Defined , enter the paper width and height.	
Orientation	Select the orientation you want to use to print.	
Paper Type	Select the type of paper on which you print.	
Quality	Select the print quality you want to use for printing. Available settings depend on the paper type you select.	
Color	Select the color for your print job.	
2-Sided Printing	Allows you to perform 2-sided printing.	
	Settings	You can specify the binding edge and the binding margins. When printing multi-page documents, you can select to print starting from either the front or the back side of the page.
	Print Density	Select the document type to adjust the print density. If the appropriate print density is selected, you can prevent images from bleeding through to the reverse side. Select User Defined to adjust the print density manually.
Multi-Page	Allows you to print several pages on one sheet or perform poster printing. Click Page Order to specify the order in which pages are printed.	
Copies	Set the number of copies you want to print.	
	Collate	Prints multi-page documents collated in order and sorted into sets.
	Reverse Order	Allows you to print from the last page so that the pages are stacked in the correct order after printing.
Quiet Mode	Reduces the noise the printer makes. However, enabling this may reduce print speed.	
Print Preview	Displays a preview of your document before printing.	
Job Arranger Lite	Select to print using the Job Arranger Lite feature.	

Printing

More Options Tab

Printing Presets	Add/Remove Presets	You can add or remove your own presets for frequently used print settings. Select the preset you want to use from the list.
Show Settings	Displays a list of items currently set on the Main and More Options tabs.	
Reset Defaults	Return all settings to their factory default values. The settings on the Main tab are also reset to their defaults.	
Document Size	Select the size of your document.	
Output Paper	Select the paper size on which you want to print. If the Output Paper differs from Document Size , Reduce/Enlarge Document is selected automatically. You do not have to select Output Paper when printing documents without changing the size.	
Reduce/Enlarge Document	Allows you to reduce or enlarge the size of a document.	
	Fit to Page	Automatically reduce or enlarge the document to fit to the paper size selected in Output Paper .
	Zoom to	Prints with a specific percentage.
Color Correction	Center	Prints images in the center of the paper.
	Automatic	Adjusts the colors of images automatically.
	Custom	Allows you to perform manual color correction. Click Advanced for further settings.
	Image Options	Enables print quality options such as Color Universal Print or Fix Red-Eye. You can also thicken thin lines to make them visible on the printouts.
Watermark Features	Allows you to make settings for anti-copy patterns or watermarks.	
Confidential Job	Password-protect confidential documents when printing. If you use this feature, the print data is stored in the printer and can only be printed after the password has been entered using the printer's control panel. Click Settings to change the settings.	
Additional Settings	Rotate 180°	Rotates pages 180 degrees before printing. This feature is helpful when printing on paper such as envelopes that are loaded in fixed direction in the printer.
	High Speed	Prints when the print head moves in both directions. The print speed is faster, but the quality may decline.
	Mirror Image	Inverts the image so that it prints as it would appear in a mirror.

Maintenance Tab

Nozzle Check	Prints a nozzle check pattern to check if the print head nozzles are clogged.
Head Cleaning	Cleans the clogged nozzles in the print head. Because this feature uses some ink, clean the print head only if the nozzles are clogged.
Job Arranger Lite	Opens the Job Arranger Lite window. You can save and edit data.
EPSON Status Monitor 3	Opens the EPSON Status Monitor 3 window. Here you can confirm the status of the printer and the consumables.

Printing

Monitoring Preferences	Allows you to make settings for items on the EPSON Status Monitor 3 window.
Extended Settings	Allows you to make a variety of settings. Right-click each item to view the Help for more details.
Print Queue	Displays the jobs waiting to be printed. You can check, pause, or resume print jobs.
Printer and Option Information	You can register user accounts. If access control is set on the printer, you must register your account.
Language	Changes the language to be used on the printer driver window. To apply the settings, close the printer driver, and then open it again.
Software Update	Starts EPSON Software Updater to check for the latest version of applications on the Internet.
Technical Support	Allows you to access the Epson technical support website.

Printing from the PostScript Printer Driver on Windows

A PostScript Printer Driver is a driver that outputs printing commands to a printer using a PostScript Page Description Language.

1. Open the file you want to print.
Load paper in the printer if it has not already been loaded.
2. Select **Print** or **Print Setup** from the **File** menu
3. Select your printer.
4. Select **Preferences** or **Properties** to access the printer driver window.

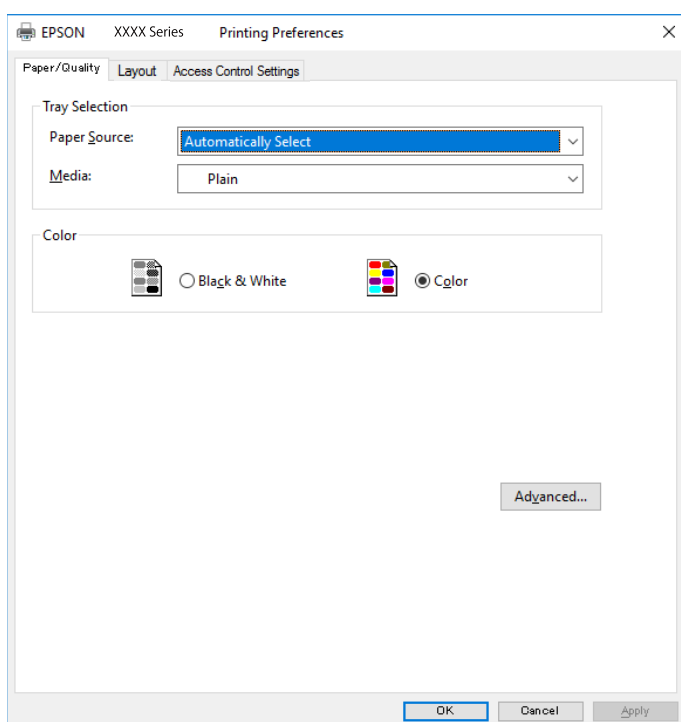

Printing

5. Change the settings as necessary.
See the menu options for the printer driver for details.
6. Click **OK** to close the printer driver for details.
7. Click **Print**.

Related Information

- ➔ [“Available Paper and Capacities” on page 27](#)
- ➔ [“Loading Paper in the Paper Cassette” on page 32](#)
- ➔ [“Loading Paper in the Rear Paper Feed” on page 34](#)
- ➔ [“List of Paper Type” on page 38](#)
- ➔ [“Paper/Quality Tab” on page 147](#)
- ➔ [“Layout Tab” on page 147](#)

Menu Options for the PostScript Printer Driver

Open the print window on an application, select the printer, and then access the printer driver window.

Note:

Menus vary depending on the option you selected.

Paper/Quality Tab

Tray Selection	Paper Source	Select the paper source from which the paper is fed. Select Automatically Select to automatically select the paper source selected in the Paper Setting on the printer.
	Media	Select the type of paper on which you print.
Color	Select the color for your print job.	

Layout Tab

Orientation	Select the orientation you want to use to print.		
Print on Both Sides	Allows you to perform 2-sided printing.		
Page Order	Select to print from the top or the last page. If you select Back to Front , the pages are stacked in the correct order based on page number after printing.		
Page Format	Pages per Sheet	Allows you to print several pages on one sheet.	
		Pages per Sheet Layout	Allows you to specify the page layout when printing several pages on one sheet.
	Booklet	Select to create a booklet.	
		Booklet Binding	Select the binding position for booklet.

Printing

Access Control Settings Tab

Printer usage may have been restricted by the administrator. Printing is available after registering your account to the printer driver. Contact the administrator for details on your user account.

Access Control Settings	User Registration	Allows you to enter a user name and password.
	User Name	Enter a user name.
	Password	Enter a password.

Advanced Options

Paper/Output	Paper Size	Select the paper size on which you want to print.		
	Copies	Set the number of copies you want to print.		
Graphic	Print Quality	Select the print quality you want to use for printing.		
	Image Color Management	Select the ICM method or intent.		
	Scaling	Allows you to reduce or enlarge the document.		
	TrueType Font	Sets the font substitute to TrueType Font.		
Document Options	Advanced Printing Features	Allows you to make detailed settings for printing features.		
	PostScript Options	Allows you to make optional settings.		
	Printer Features	Color Mode	Select whether to print in color or in monochrome.	
		Press Simulation	You can select a CMYK ink color to simulate when you print by reproducing the CMYK ink color of the offset press.	
		Ink Save Mode	Conserves ink by reducing the print density.	
Rotate by 180°		Rotates the data 180 degrees before printing.		

Canceling Printing

You can cancel a print job from the computer. However, you cannot cancel a print job from the computer once it has been completely sent to the printer. In this case, cancel the print job by using the printer's control panel.

Canceling

On your computer, right-click on your printer in **Devices and Printers**, **Printer**, or in **Printers and Faxes**. Click **See what's printing**, right-click on the job you want to cancel, and then select **Cancel**.

Printing from the Printer Driver on Mac OS

Printing Basics

Note:

Operations differ depending on the application. See the application's help for details.

1. Open the file you want to print.
Load paper in the printer if it has not already been loaded.
2. Select **Print** from the **File** menu or another command to access the print dialog.
If necessary, click **Show Details** or ▼ to expand the print window.
3. Select your printer.
4. Select **Print Settings** from the pop-up menu.

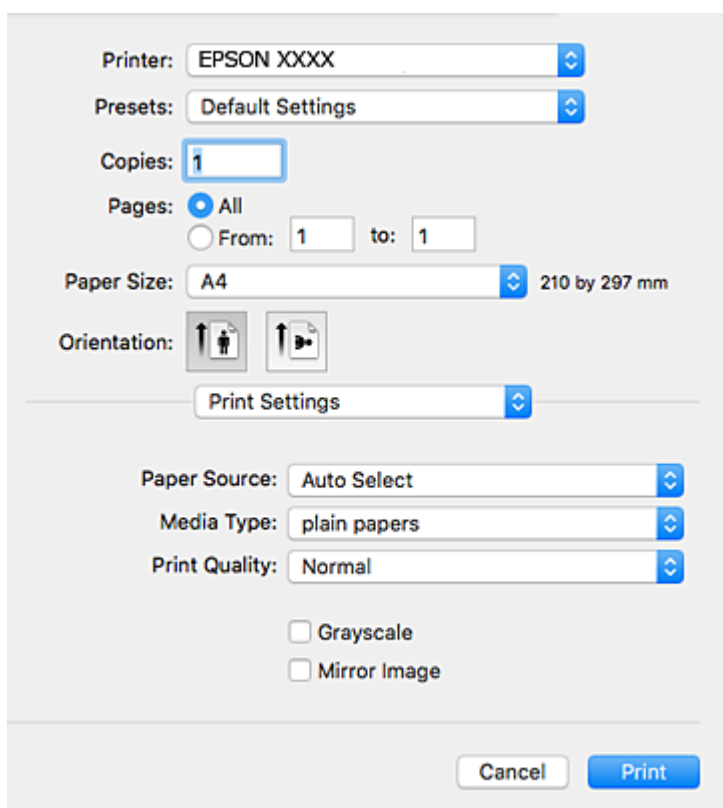
**Note:**

On OS X Mountain Lion or later, if the **Print Settings** menu is not displayed, the Epson printer driver has not been installed correctly.

Select **System Preferences** from the  menu > **Printers & Scanners** (or **Print & Scan**, **Print & Fax**), remove the printer, and then add the printer again. See the following to add a printer.

<http://epson.sn>

Printing

5. Change the settings as necessary.
See the menu options for the printer driver for details.
6. Click **Print**.

Related Information

- ➔ [“Available Paper and Capacities” on page 27](#)
- ➔ [“Loading Paper in the Paper Cassette” on page 32](#)
- ➔ [“Loading Paper in the Rear Paper Feed” on page 34](#)
- ➔ [“List of Paper Type” on page 38](#)
- ➔ [“Menu Options for Print Settings” on page 154](#)

Printing on 2-Sides

You can print on both sides of the paper.

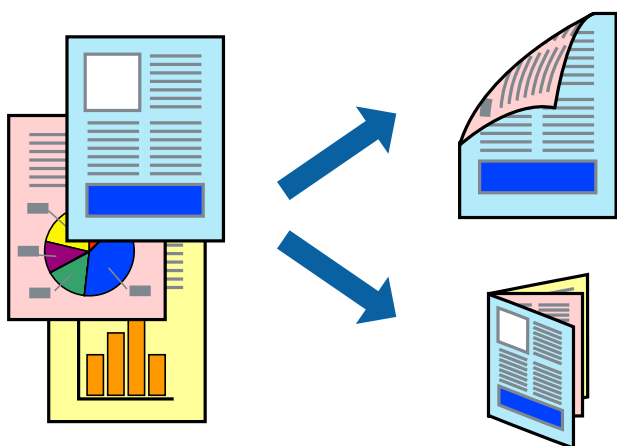

Note:

- If you do not use paper that is suitable for 2-sided printing, the print quality may decline and paper jams may occur.
- Depending on the paper and the data, ink may bleed through to the other side of the paper.

Related Information

- ➔ [“Available Paper and Capacities” on page 27](#)

Print Settings

Select **Two-sided Printing Settings** from the pop-up menu. Select the method of 2-sided printing, and then make the **Document Type** settings.

Note:

- Printing speed may be reduced depending on the document type.
- When printing photos with dense data, select **Text & Graphics** or **Text & Photos** in the **Document Type** setting. If the printouts are smeared or ink bleeds through to the other side of the paper, adjust the **Print Density** and **Increased Ink Drying Time** in **Adjustments**.

Printing

Related Information

- ➔ “Printing Basics” on page 149
- ➔ “Menu Options for Two-sided Printing Settings” on page 155

Printing Several Pages on One Sheet

You can print two or four pages of data on a single sheet of paper.

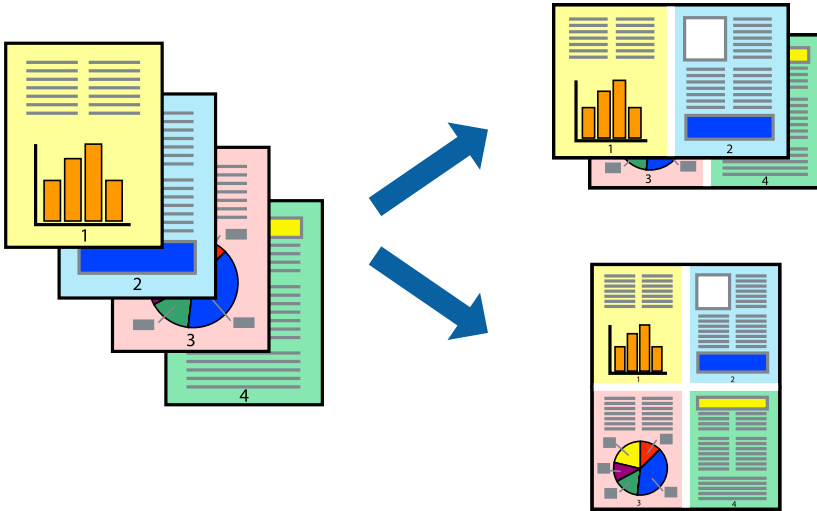

Print Settings

Select **Layout** from the pop-up menu. Set the number of pages in **Pages per Sheet**, the **Layout Direction** (page order), and **Border**.

Related Information

- ➔ “Printing Basics” on page 149
- ➔ “Menu Options for Layout” on page 154

Printing and Stacking in Page Order (Reverse Order Printing)

You can print from the last page so that the documents are stacked in page order.

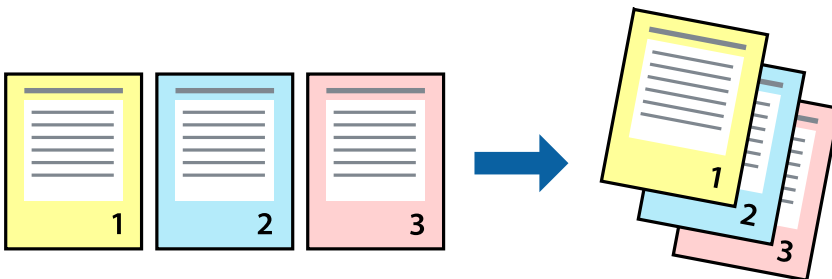

Printing

Print Settings

Select **Paper Handling** from the pop-up menu. Select **Reverse** as the **Page Order** setting.

Related Information

- ➔ [“Printing Basics” on page 149](#)
- ➔ [“Menu Options for Paper Handling” on page 154](#)

Printing a Reduced or Enlarged Document

You can reduce or enlarge the size of a document by a specific percentage or to fit the paper size you loaded in the printer.



Print Settings

When printing to fit to the paper size, select **Paper Handling** from the pop-up menu, and then select **Scale to fit paper size**. Select the paper size you loaded in the printer in **Destination Paper Size**. When reducing the size of the document, select **Scale down only**.

When printing at a specific percentage, do one of the following.

- Select **Print** from the **File** menu of the application. Select **Printer**, enter a percentage in **Scale**, and then click **Print**.
- Select **Page Setup** from the **File** menu of the application. Select your printer in **Format For**, enter a percentage in **Scale**, and then click **OK**.

Note:

Select the paper size you set in the application as the **Paper Size** setting.

Related Information

- ➔ [“Printing Basics” on page 149](#)
- ➔ [“Menu Options for Paper Handling” on page 154](#)

Adjusting the Print Color

You can adjust the colors used in the print job.

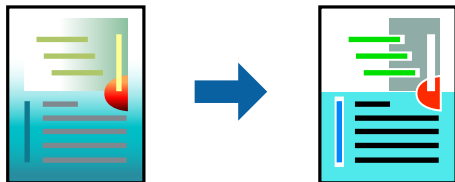

Note:

These adjustments are not applied to the original data.

Print Settings

Select **Color Matching** from the pop-up menu, and then select **EPSON Color Controls**. Select **Color Options** from the pop-up menu, and then select one of the available options. Click the arrow next to **Advanced Settings**, and then make more detailed settings.

Related Information

- ➔ [“Printing Basics” on page 149](#)
- ➔ [“Menu Options for Color Matching” on page 154](#)
- ➔ [“Menu Options for Color Options” on page 155](#)

Canceling Printing

You can cancel a print job from the computer. However, you cannot cancel a print job from the computer once it has been completely sent to the printer. In this case, cancel the print job by using the printer's control panel.

Canceling

Click the printer icon in the **Dock**. Select the job you want to cancel, and then do one of the following.

- OS X Mountain Lion or later

Click  next to the progress meter.

- Mac OS X v10.6.8 to v10.7.x

Click **Delete**.

Menu Options for the Printer Driver

Open the print window in an application, select the printer, and then access the printer driver window.

Note:

Menus vary depending on the option you selected.

Printing

Menu Options for Layout

Pages per Sheet	Select the number of pages to be printed on one sheet.
Layout Direction	Specify the order in which the pages will be printed.
Border	Prints a border around the pages.
Reverse page orientation	Rotates pages 180 degrees before printing. Select this item when printing on paper such as envelopes that are loaded in fixed direction in the printer.
Flip horizontally	Inverts an image to print as it would appear in a mirror.

Menu Options for Color Matching

ColorSync	Select the method for color adjustment. These options adjust colors between the printer and the computer display to minimize the difference in color.
EPSON Color Controls	

Menu Options for Paper Handling

Collate pages	Prints multi-page documents collated in order and sorted into sets.	
Pages to Print	Select to print only odd pages or even pages.	
Page Order	Select to print from the top or the last page.	
Scale to fit paper size	Prints to fit to the paper size you loaded.	
	Destination Paper Size	Select the paper size to print on.
	Scale down only	Select when reducing the size of the document.

Menu Options for Cover Page

Print Cover Page	Select whether or not to print a cover page. When you want to add a back cover, select After document .
Cover Page Type	Select the contents of the cover page.

Menu Options for Print Settings

Paper Source	Select the paper source from which the paper is fed. If the printer has only one paper source, this item is not displayed. Selecting Auto Select selects the paper source that matches the Paper Setting on the printer automatically.
Media Type	Select the type of paper on which you print.
Print Quality	Select the print quality you want to use for printing. The options vary depending on the paper type.

Printing

Grayscale	Select when you want to print in black or shades of gray.
Mirror Image	Inverts an image to print as it would appear in a mirror.

Menu Options for Color Options

Manual Settings	Adjusts the color manually. In Advanced Settings , you can select detailed settings.
PhotoEnhance	Produces sharper images and more vivid colors by automatically adjusting the contrast, saturation, and brightness of the original image data.
Off (No Color Adjustment)	Print without enhancing or adjusting the color in any way.

Menu Options for Two-sided Printing Settings

Two-sided Printing	Prints on both sides of the paper.
--------------------	------------------------------------

Making Operation Settings for the Mac OS Printer Driver

Accessing the Operation Settings Window of the Mac OS Printer Driver

Select **System Preferences** from the  menu > **Printers & Scanners** (or **Print & Scan**, **Print & Fax**), and then select the printer. Click **Options & Supplies** > **Options** (or **Driver**).

Operation Settings of the Mac OS Printer Driver

- Thick paper and envelopes:** Prevents the ink from smearing when printing on thick paper. However, this may reduce print speed.
- Skip Blank Page:** Avoids printing blank pages.
- Quiet Mode:** Reduces the noise the printer makes, however, may reduce print speed.
- Permit temporary black printing:** Prints only with black ink temporarily.
- High Speed Printing:** Prints when the print head moves in both directions. The print speed is faster, but the quality may decline.
- Output documents for filing:** Feed the paper so that it is easy to file when printing landscape data or 2-sided printing. Envelope printing is not supported.
- Warning Notifications:** Allows the printer driver to display warning notifications.
- Establish bidirectional communication:** Usually, this should be set to **On**. Select **Off** when acquiring the printer information is impossible because the printer is shared with Windows computers on a network or for any other reason.
- Lower Cassette:** Add the optional paper cassette units to the paper source.

Printing from the PostScript Printer Driver on Mac OS

A PostScript Printer Driver is a driver that outputs printing commands to a printer using a PostScript Page Description Language.

1. Open the file you want to print.
Load paper in the printer if it has not already been loaded.
2. Select **Print** or **Print Setup** from the **File** menu.
If necessary, click **Show Details** or ▼ to expand the print window.
3. Select your printer.
4. Select **Print Features** from the pop-up menu.

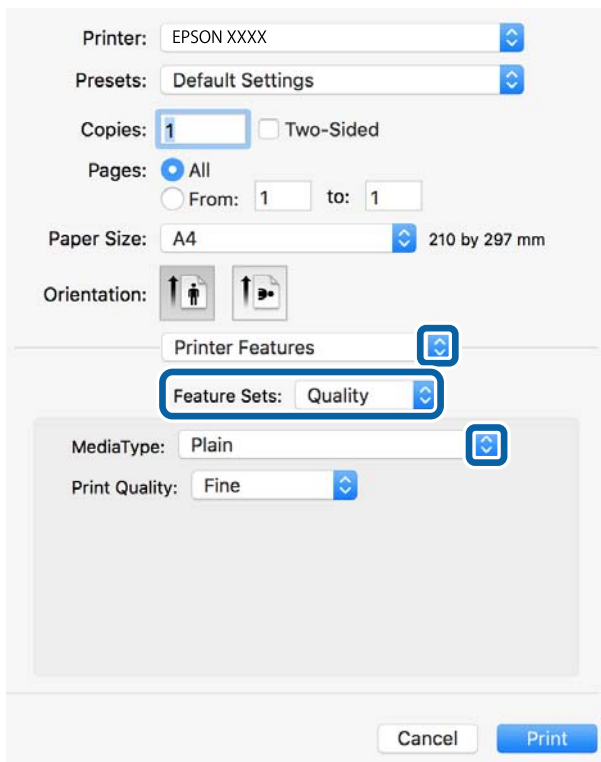

5. Change the settings as necessary.
See the menu options for the printer driver for details.
6. Click **Print**.

Related Information

- ➔ [“Available Paper and Capacities” on page 27](#)
- ➔ [“Loading Paper in the Paper Cassette” on page 32](#)
- ➔ [“Loading Paper in the Rear Paper Feed” on page 34](#)
- ➔ [“List of Paper Type” on page 38](#)
- ➔ [“Menu Options for Printer Features” on page 158](#)

Printing

Menu Options for the PostScript Printer Driver

Open the print window on an application, select the printer, and then access the printer driver window.

Note:

Menus vary depending on the option you selected.

Menu Options for Layout

Pages per Sheet	Select the number of pages to be printed on one sheet.
Layout Direction	Specify the order in which the pages will be printed.
Border	Prints a border around the pages.
Two-Sided	Allows you to perform 2-sided printing.
Reverse page orientation	Rotates pages 180 degrees before printing.
Flip horizontally	Inverts the image so that it prints as it would appear in a mirror.

Menu Options for Color Matching

ColorSync	Select the method for color adjustment. These options adjust color between the printer and the computer display to minimize the difference in color.
In Printer	

Menu Options for Paper Handling

Collate pages	Prints multi-page documents collated in order and sorted into sets.	
Pages to Print	Select to print only odd pages or even pages.	
Page Order	Select to print from the top or the last page.	
Scale to fit paper size	Prints to fit to the paper size you loaded.	
	Destination Paper Size	Select the paper size to print on.
	Scale down only	Select when reducing the size of the document.

Menu Options for Paper Feed

All Pages From	Select the paper source from which the paper is fed.
First Page From/ Remaining From	Selecting Auto Select selects the paper source that matches the Paper Setting on the printer automatically. You can also select the paper source for page.

Printing

Menu Options for Cover Page

Print Cover Page	Select whether or not to print a cover page. When you want to add a back cover, select After document .
Cover Page Type	Select the contents of the cover page.

Menu Options for Printer Features

Feature Sets	Quality	MediaType	Select the type of paper on which you print.
		Print Quality	Select the print quality you want to use for printing.
	Color	Color Mode	Select whether to print in color or in monochrome.
		Press Simulation	You can select a CMYK ink color to simulate when you print by reproducing the CMYK ink color of the offset press.
	Others	Ink Save Mode	Conserves ink by reducing the print density.

Canceling Printing

You can cancel a print job from the computer. However, you cannot cancel a print job from the computer once it has been completely sent to the printer. In this case, cancel the print job by using the printer's control panel.

Canceling

Click the printer icon in the **Dock**. Select the job you want to cancel, and then do one of the following.

- OS X Mountain Lion or later

Click  next to the progress meter.

- Mac OS X v10.6.8 to v10.7.x

Click **Delete**.

Printing Files from a Memory Device

You can print JPEG, PDF, and TIFF files from a memory device connected to the printer.

Printing JPEG Files from a Memory Device

Note:

If you have more than 999 images on your memory device, images are automatically divided into groups and the group selection screen is displayed. Images are sorted by the date they were taken.

1. Connect the memory device to the printer's external interface USB port.

Printing

2. Select **Memory Device** on the home screen.



3. Select **JPEG**.

The images on the memory device are displayed as thumbnails.

Select  to change the **Display order** or make settings for **Select All Images**, **Cancel Image Selection**, and **Select Group**.

4. Select the files you want to print.

Selected images have check marks on them.

To preview one image, select **Single View**. You can enlarge the image by using . Use  or  to preview the previous or next image.

5. Select **Proceed to Print** to make the print settings.

6. Set the paper source and the color mode that you want to use on the **Basic Settings** tab.

7. Set the other items on the **Advanced** tab as necessary.

For more information on detailed settings, see the menus for Memory Device.

8. Enter the number of copies.

9. Tap  to start printing.

10. Remove the memory device from the printer.

Related Information

➔ [“JPEG Settings” on page 160](#)

Printing PDF or TIFF Files from a Memory Device

1. Connect the memory device to the printer's external interface USB port.

2. Select **Memory Device** on the home screen.

3. Select **PDF** or **TIFF**.

The files on the memory device are displayed as a list.

To change the order of the files, select .

4. Select the file you want to print.

5. Set the paper source and the color mode that you want to use on the **Basic Settings** tab.

6. Set the other items on the **Advanced** tab as necessary.

For more information on detailed settings, see the menus for Memory Device.

7. Enter the number of copies.

Printing

8. Tap  to start printing.
9. Remove the memory device from the printer.

Related Information

- ➔ [“PDF Settings” on page 161](#)
- ➔ [“TIFF Settings” on page 161](#)

Menu Options for Memory Device

Select **Memory Device** on the printer's home screen to make various print settings for the file on the memory device.

JPEG Settings

 (Options) :

Make settings for ordering, selecting, and deselecting image data.

Basic Settings:

- Paper Setting
Specify the paper source settings which you want to print on.
- Color Mode
Select a color setting whether you normally print in **B&W** or **Color**.

Advanced:

- Layout
Select how to layout the JPEG files. **1-up** is for printing one file per sheet. **20-up** is for printing 20 files on one sheet. **Index** is for making index printing with information.
- Fit Frame
Select **On** to crop the image to fit into the selected print layout automatically. If the aspect ratio of the image data and the paper size is different, the image is automatically enlarged or reduced so that the short sides match the short sides of the paper. The long side of the image is cropped if it extends beyond the long side of the paper. This feature may not work for panorama photos.
- Quality
Select **Best** for higher quality printing, but the printing speed may be slower.
- Date
Select the format of the date the photo was taken or saved. The date is not printed for some layouts.
- Fix Photo
Select this mode to improve the brightness, contrast, and saturation of the photo automatically. To turn off automatic improvement, select **Enhance Off**.

Printing

- Fix Red-Eye

Select **On** to automatically fix the red-eye effect in photos. Corrections are not applied to the original file, only to the printouts. Depending on the type of photo, parts of the image other than the eyes may be corrected.

PDF Settings

You can make print settings for PDF format files on your memory devices.

-  (Display order) :

Select a sort setting to display the files on the LCD screen.

Basic Settings:

- Paper Setting

Specify the paper source settings which you want to print on.

- Color Mode

Select a color setting whether you normally print in **B&W** or **Color**.

Advanced:

- 2-Sided

Select **On** to print PDF files using 2-Sided printing. You can also select the binding method by selecting **Binding(Copy)**.

- Print Order

Select the order for printing multi-page PDF files.

TIFF Settings

You can make print settings for TIFF format files in you memory devices.

-  (Display order) :

Changes the order of the files.

Basic Settings:

- Paper Setting

Specify the paper source settings which you want to print on.

- Color Mode

Select a color setting whether you normally print in **B&W** or **Color**.

Advanced:

- Layout

Select how to layout the Multi-TIFF file. **1-up** is for printing one page per sheet. **20-up** is for printing 20 pages on one sheet. **Index** is for making index printing with information.

Printing

 Fit Frame

Select **On** to crop the photo to fit into the selected photo layout automatically. If the aspect ratio of the image data and the paper size is different, the image is automatically enlarged or reduced so that the short sides match the short sides of the paper. The long side of the image is cropped if it extends beyond the long side of the paper. This feature may not work for panorama photos.

 Quality

Select **Best** for higher quality printing, but the printing speed may be slower.

 Print Order

Select the order for printing multi-page TIFF files.

 Date

Select the format of the date the photo was taken or saved. The date is not printed for some layouts.

Printing from Smart Devices

Using Epson iPrint

Epson iPrint is an application that allows you to print photos, documents, and web pages from a smart device such as a smartphone or tablet. You can use local print, printing from a smart device that is connected to the same wireless network as your printer, or remote print, printing from a remote location over the Internet. To use remote print, register your printer in the Epson Connect service.

If you start Epson iPrint when the printer is not connected to the network, a message is displayed instructing you to connect to the printer. Follow the instructions to complete the connection. See the URL below for the operating conditions.

<http://epson.sn>



Related Information

➔ [“Printing Using a Network Service” on page 247](#)

Installing Epson iPrint

You can install Epson iPrint on your smart device from the following URL or QR code.

<http://ipr.to/c>



Printing

Printing Using Epson iPrint

Start Epson iPrint from your smart device and select the item you want to use from the home screen.

The following screens are subject to change without notice. The contents may vary depending on the product.

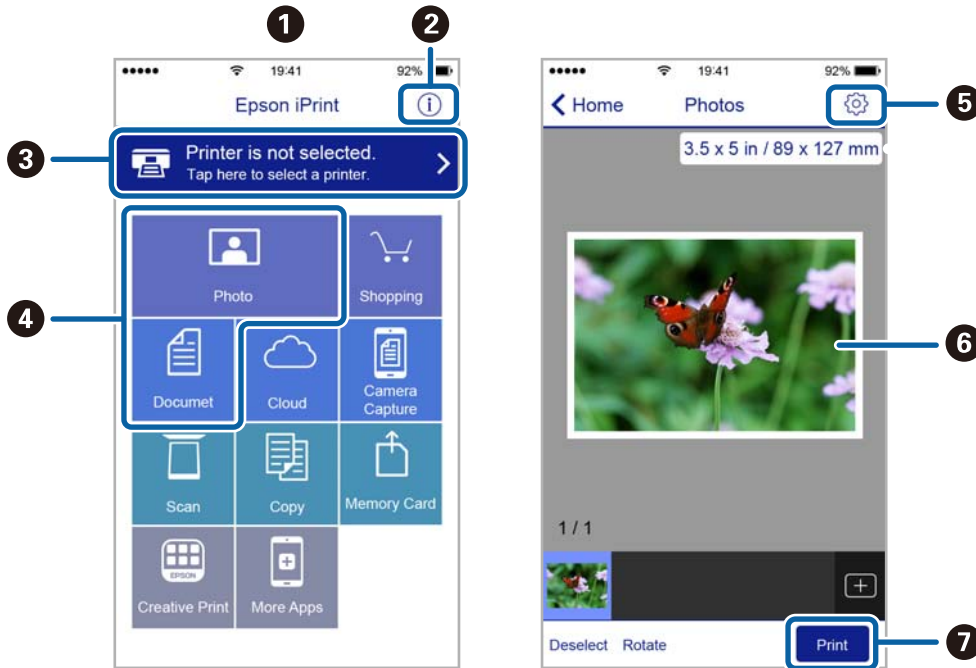

1	Home screen displayed when the application is started.
2	Displays information on how to setup the printer and a FAQ.
3	Displays the screen where you can select the printer and make printer settings. Once you have selected the printer, you do not need to select it again from the next time.
4	Select what you want to print such as photos and documents.
5	Displays the screen to make print settings such as paper size and paper type.
6	Displays photos and documents you selected.
7	Starts printing.

Note:

To print from the document menu using iPhone, iPad, and iPod touch running iOS, start Epson iPrint after transferring the document you want to print using the file sharing function in iTunes.

Using Epson Print Enabler

You can wirelessly print your documents, emails, photos, and web pages right from your Android phone or tablet (Android v4.4 or later). With a few taps, your Android device will discover an Epson printer that is connected to the same wireless network.

1. Load paper in the printer.
2. Set up your printer for wireless printing.

Printing

3. On your Android device, install the Epson Print Enabler plug-in from Google Play.
4. Connect your Android device to the same wireless network as your printer.
5. Go to **Settings** on your Android device, select **Printing**, and then enable Epson Print Enabler.
6. From an Android application such as Chrome, tap the menu icon and print whatever is on the screen.

Note:

*If you do not see your printer, tap **All Printers** and select your printer.*

Related Information

- ➔ “Loading Paper in the Paper Cassette” on page 32
- ➔ “Loading Paper in the Rear Paper Feed” on page 34

Using AirPrint

AirPrint enables instant wireless printing from iPhone, iPad, and iPod touch with the latest version of iOS, and Mac with the latest version of OS X or macOS.



Note:

If you disabled paper configuration messages on your product control panel, you cannot use AirPrint. See the link below to enable the messages, if necessary.

1. Load paper in your product.
2. Set up your product for wireless printing. See the link below.
<http://epson.sn>
3. Connect your Apple device to the same wireless network that your product is using.
4. Print from your device to your product.

Note:

For details, see the AirPrint page on the Apple website.

Related Information

- ➔ “Loading Paper in the Paper Cassette” on page 32
- ➔ “Loading Paper in the Rear Paper Feed” on page 34

Canceling Ongoing or Queued Jobs

Note:

You can also cancel the ongoing jobs by tapping  on the printer's control panel.

1. Press the  button to display **Job/Status**.
2. Select **Active** on the **Job Status** tab.
Ongoing print jobs and jobs that are standing by are shown in the list.
3. Select the job that you want to cancel.
4. Select **Cancel**.

Copying

Copying Basics

This section explains the steps for basic copying.

1. Place the originals.

If you want to copy multiple originals or make 2-sided copies, place all of the originals on the ADF.

2. Select **Copy** on the home screen.

3. Check the settings in **Basic Settings** tab.

Select the setting item to change it as necessary.

Note:

If you select **Advanced** tab, you can make settings such as **Multi-Page** or **Original Type**.

If you select , you can register frequently used copy settings as presets.

If the combination of settings you require is not available,  is displayed. Select the icon to check the details, and then change the settings.

Select  to check the scanned image before start copying.

This is only available when you placing the original on the scanner glass.

4. Enter the number of copies.

5. Tap .

Related Information

➔ [“Placing Originals” on page 39](#)

➔ [“Basic Menu Options for Copying” on page 167](#)

➔ [“Advanced Menu Options for Copying” on page 168](#)

Copying on 2-Sides

You can copy multiple originals or 2-sided documents on both sides of the paper.

1. Select **Copy** on the home screen.

2. Select **2-Sided**, and then select **1→2-Sided** or **2→2-Sided**.

You can also specify the orientation and binding position of the original and the copy result.

3. Set the other items as necessary.

4. Tap .

Copying

Related Information

➔ [“Copying Basics” on page 166](#)

Copying Multiple Originals onto One Sheet

You can copy two or four originals onto a single sheet of paper.

1. Select **Copy** on the home screen.
2. Select **Advanced** tab > **Multi-Page**, and select **2-up** or **4-up**.
You can also specify the layout order and orientation of the original.
3. Tap .

Related Information

➔ [“Copying Basics” on page 166](#)

Basic Menu Options for Copying

Note:

The items may not be available depending on other settings you made.

B&W/Color:

Select whether to copy in color or in monochrome.

Density:

Increase the level of density when the copying results are faint. Decrease the level of density when ink smears.

Paper Setting:

Select the paper source that you want to use. When **Auto** is selected, paper is fed automatically using the **Paper Setting** settings made when you loaded the paper.

Reduce/Enlarge:

Configures the magnification ratio of the enlargement or reduction. If you want to reduce or enlarge the original by a specific percentage, select the value, and then enter a percentage within a range of 25 to 400%.

Copying

Auto Fit Page

Detects the scan area and automatically enlarges or reduces the original to fit to the paper size you selected. When there are white margins around the original, the white margins from the corner mark of the scanner glass are detected as the scan area, but the margins at the opposite side may be cropped.

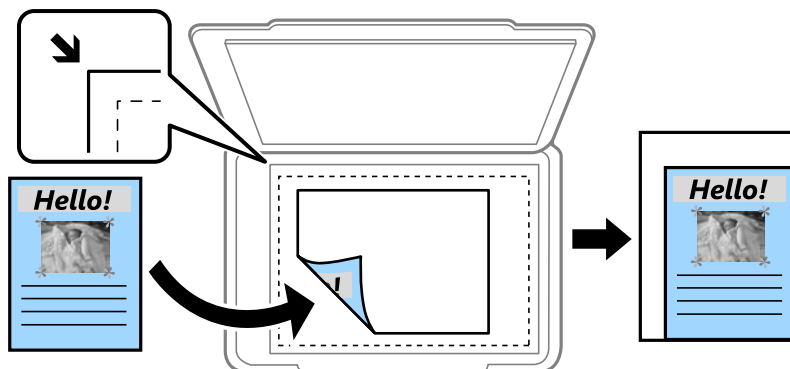

Actual Size

Copies at 100 % magnification.

A4→A5 and others

Automatically enlarges or reduces the original to fit a specific paper size.

Original Size:

Select the size of your original. When copying non-standard size originals, select the size closest to your original.

2-Sided:

Select 2-sided layout.

1→1-Sided

Copies one side of an original onto a single side of paper.

2→2-Sided

Copies both sides of a double-sided original onto both sides of a single sheet of paper. Select the orientation of your original and the binding position of the original and the paper.

1→2-Sided

Copies two single-sided originals onto both sides of a single sheet of paper. Select the orientation of your original and the binding position of the paper.

2→1-Sided

Copies both sides of a double-sided original onto one side of two sheets of paper. Select the orientation of your original and the binding position of the original.

Advanced Menu Options for Copying

Note:

The items may not be available depending on other settings you made.

Copying

Multi-Page:

Select the copy layout.

Single Page

Copies a single-sided original onto a single sheet.

2-up

Copies two single-sided originals onto a single sheet in 2-up layout. Select the layout order and the orientation of your original.

4-up

Copies four single-sided originals onto a single sheet in 4-up layout. Select the layout order and the orientation of your original.

Original Type:

Select the type of your original. Copies in optimal quality to match the type of original.

Finishing:

Select how to eject the paper for multiple copies of multiple originals.

Group (Same Pages)

Copies the originals by page as a group.

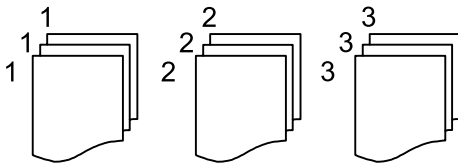

Collate (Page Order)

Copies the originals collated in order and sorted into sets.

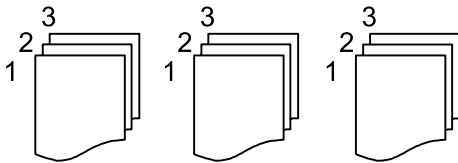

Orientation (Original):

Select the orientation of your original.

Image Quality:

Adjust image settings.

Contrast

Adjust the difference between the bright and dark parts.

Saturation

Adjust the vividness of the colors.

Red Balance, Green Balance, Blue Balance

Adjust the density for each color.

Copying

Sharpness

Adjust the outline of the image.

Hue Regulation

Adjust the color tone of the skin. Select + to make it cold (increase green) and select - to make it warm (increase red).

Remove Background

Adjust the density of the background color. Select + to make it bright (white) and select - to make it dark (black).

Binding Margin:

Select the binding position, margin, and orientation of your original for 2-sided copy.

Reduce to Fit Paper:

Copies the scanned image at a smaller size than the Reduce/Enlarge value to fit within the paper size. If the Reduce/Enlarge value is larger than the paper size, data may be printed beyond the edges of the paper.

Remove Shadow:

Removes shadows that appear around copies when copying thick paper or that appear in the center of copies when copying a booklet.

Remove Punch Holes:

Removes the binding holes when copying.

ID Card Copy:

Scans both sides of an ID card and copies onto one side of paper.

Scanning

Scanning Using the Control Panel

You can send scanned images from the printer's control panel to the following destinations.

Network Folder/FTP

You can save the scanned image to a folder on a network. You can specify a shared folder on the computer, created using SMB protocols, or a folder on an FTP sever. Before scanning, you need to set a shared folder or FTP server.

Email

You can send scanned image files by email directly from the printer through a pre-configured email server. Before scanning, you need to configure the email server.

Computer

You can perform jobs created by the scanning software *Document Capture Pro* from the printer's control panel. When you create a job that saves the scanned image to the computer, you can run the job from the printer and save the scanned image to your computer. Before scanning, install Document Capture Pro on your computer and create a job.

Memory Device

You can save the scanned image to a memory device. You need not set any settings before scanning.

Cloud

You can send scanned images to cloud services. Before scanning, make settings on the Epson Connect.

WSD

You can save the scanned image to a computer connected to the printer, using WSD feature. If you are using the Windows 7/Windows Vista, you need to make WSD settings on your computer before scanning.

Related Information

- ➔ [“Scanning to a Network Folder or FTP Server” on page 171](#)
- ➔ [“Scanning to an Email” on page 174](#)
- ➔ [“Scanning Using the Settings Registered on the Computer \(Document Capture Pro\)” on page 177](#)
- ➔ [“Scanning to a Memory Device” on page 180](#)
- ➔ [“Scanning to the Cloud” on page 182](#)

Scanning to a Network Folder or FTP Server

You can save the scanned image to a specified folder on a network. You can specify the folder by entering a folder path directly, but it may be easier if you register the folder information in the contacts list first.

Before scanning, you need to set a shared folder or FTP server.

Scanning

Note:

- ❑ Before you use this feature, make sure the printer's **Date/Time** and **Time Difference** settings are correct. Access the menus from **Settings > General Settings > Basic Settings > Date/Time Settings**.
- ❑ You can check destination before scanning. Select **Settings > General Settings > Scan Settings**, and then enable **Confirm Recipient**.

1. Place the originals.

Note:

If you want to scan multiple originals or make a 2-sided scan, place all of the originals on the ADF.

2. Select **Scan** on the home screen.

3. Select **Network Folder/FTP**.

4. Specify the folder.

- ❑ To select from frequently used addresses: Select the icons displayed on the screen.

- ❑ To enter the folder path directly: Select **Keyboard**. Select **Communication Mode**, enter the folder path as the **Location (Required)**, and then make other folder settings.

Enter the folder path in the following format.

When using SMB as the communication mode: \\host name\folder name

When using FTP as the communication mode: ftp://host name/folder name

- ❑ To select from the contacts list: Select **Contacts**, select a contact, and then select **Close**.

You can search for a folder from the contacts list. Enter the search keyword into the box at the top of the screen.

Note:

You can print the history of the folder in which documents are saved, by selecting .

5. Select **Scan Settings**, and then check settings such as the save format, and change them if necessary.

Note:

Select  to save your settings as a preset.

6. Tap .

Related Information

- ➔ [“Setting a Shared Folder” on page 52](#)
- ➔ [“Managing Contacts” on page 49](#)
- ➔ [“Placing Originals” on page 39](#)
- ➔ [“Registering Your Favorite Settings as a Preset” on page 55](#)

Destination Menu Options for Scanning to a Folder

Keyboard:

Open the **Edit Location** screen. Enter the folder path and set each item on the screen.

- ❑ Communication Mode

Select the communication mode.

Scanning

- Location (Required)
Enter a folder path in which to save the scanned image.
- User Name
Enter a user name for the specified folder.
- Password
Enter a password for the specified folder.
- Connection Mode
Select the connection mode.
- Port Number
Enter a port number.

Contacts:

Select a folder in which to save the scanned image from the contacts list. You do not need to make location settings when you have selected a folder from the contacts list.

Scan Menu Options for Scanning to a Folder

Note:

The items may not be available depending on other settings you made.

Color Mode:

Select whether to scan in color or in monochrome.

File Format:

Select the format in which to save the scanned image.

- Compression Ratio
Select how much to compress the scanned image.
- PDF Settings
When you have selected **PDF** as the save format setting, use these settings to protect PDF files.
To create a PDF file that requires a password when opening, set **Document Open Password**. To create a PDF file that requires a password when printing or editing, set **Permissions Password**.

Resolution:

Select the scanning resolution.

2-Sided:

Scan both sides of the original.

- Orientation (Original)
Select the orientation of the original.
- Binding(Original)
Select the binding direction of the original.

Scanning

Scan Area:

Select the scan area. To crop the white space around the text or image when scanning, select **Auto Cropping**. To scan at the maximum area of the scanner glass, select **Max Area**.

- Orientation (Original)

Select the orientation of the original.

Original Type:

Select the type of your original.

Density:

Select the contrast of the scanned image.

Remove Shadow:

Remove the shadows of the original that appear in the scanned image.

- Surround

Remove the shadows at the edge of the original.

- Center

Remove the shadows of the binding margin of the booklet.

Remove Punch Holes:

Remove the punch holes that appear in the scanned image. You can specify the area to erase the punch holes by entering a value in the box on the right.

- Erasing Position

Select the position to remove the punch holes.

- Orientation (Original)

Select the orientation of the original.

File Name:

- Filename Prefix

Enter a prefix for the name of the images in alphanumeric characters and symbols.

- Add Date

Add the date to the file name.

- Add Time

Add the time to the file name.

Scanning to an Email

You can send scanned image files by email directly from the printer through a pre-configured email server. Before using this feature, you need to configure the email server.

You can specify the email address by entering directly, but it may be easier if you register the email address in the contacts list first.

Scanning

Note:

- ❑ Before you use this feature, make sure the printer's **Date/Time** and **Time Difference** settings are correct. Access the menus from **Settings > General Settings > Basic Settings > Date/Time Settings**.
- ❑ You can check destination before scanning. Select **Settings > General Settings > Scan Settings**, and then enable **Confirm Recipient**.

1. Place the originals.

Note:

If you want to scan multiple originals or make 2-sided scans, place all of the originals in the ADF.

2. Select **Scan** on the home screen.

3. Select **Email**.

4. Specify the addresses.

❑ To select frequently used addresses: Select the icons displayed on the screen.

❑ To enter the email address manually: Select **Keyboard**, enter the email address, and then select **OK**.

❑ To select from the contacts list: Select **Contacts**, select a contact or a group, and then select **Close**.

You can search for the address from the contacts list. Enter the search keyword into the box at the top of the screen.

❑ To select from the history list: Select **History**, select a contact, and then select **Close**.

Note:

❑ The number of recipients you selected is displayed on the right of the screen. You can send emails to up to 10 addresses and groups.

If groups is included in recipients, you can select up to 200 individual addresses in total, taking addresses in the groups into account.

❑ Select the address box at the top of the screen to display the list of selected addresses.

❑ Select  to display or print the sending history, or change the email server settings.

5. Select **Scan Settings**, and then check settings such as the save format, and change them if necessary.

Note:

Select  to save your settings as a preset.

6. Tap .

Related Information

- ➔ [“Managing Contacts” on page 49](#)
- ➔ [“Placing Originals” on page 39](#)
- ➔ [“Registering Your Favorite Settings as a Preset” on page 55](#)

Menu Options for Scanning to an Email

Note:

The items may not be available depending on other settings you made.

Scanning

Color Mode:

Select whether to scan in color or in monochrome.

File Format:

Select the format in which to save the scanned image.

Compression Ratio

Select how much to compress the scanned image.

PDF Settings

When you have selected **PDF** as the save format setting, use these settings to protect PDF files.

To create a PDF file that requires a password when opening, set **Document Open Password**. To create a PDF file that requires a password when printing or editing, set **Permissions Password**.

Resolution:

Select the scanning resolution.

2-Sided:

Scan both sides of the original.

Orientation (Original)

Select the orientation of the original.

Binding(Original)

Select the binding direction of the original.

Scan Area:

Select the scan area. To crop the white space around the text or image when scanning, select **Auto Cropping**. To scan at the maximum area of the scanner glass, select **Max Area**.

Orientation (Original)

Select the orientation of the original.

Original Type:

Select the type of your original.

Density:

Select the contrast of the scanned image.

Remove Shadow:

Remove the shadows of the original that appear in the scanned image.

Surround

Remove the shadows at the edge of the original.

Center

Remove the shadows of the binding margin of the booklet.

Remove Punch Holes:

Remove the punch holes that appear in the scanned image. You can specify the area to erase the punch holes by entering a value in the box on the right.

Scanning

- Erasing Position

Select the position to remove the punch holes.

- Orientation (Original)

Select the orientation of the original.

Subject:

Enter a subject for the email in alphanumeric characters and symbols.

Attached File Max Size:

Select the maximum file size that can be attached to the email.

File Name:

- Filename Prefix

Enter a prefix for the name of the images in alphanumeric characters and symbols.

- Add Date

Add the date to the file name.

- Add Time

Add the time to the file name.

Scanning Using the Settings Registered on the Computer (Document Capture Pro)

You can register a series of operations as a *job* using Document Capture Pro. Registered jobs can be performed from the printer's control panel.

If you create the job to save the scanned image to the computer, you can perform the job from the printer and save the scanned image to the computer.

Note:

Operations may vary depending on the operating system and the software version. See the software help for details on using the features.

Related Information

➔ [“Application for Configuring Scanning from the Computer \(Document Capture Pro\)” on page 240](#)

Setting a Job

Set the job on the computer using Document Capture Pro.

Note:

Operations may vary depending on the operating system and the software version. See the software help for details on using the features.

Creating and Registering a Job (Windows)

Note:

Operations may vary depending on the operating system and the software version. See the software help for details on using the features.

Scanning

1. Start Document Capture Pro.
2. Click **Job Settings** on the top screen.
The **Job List** is displayed.
3. Click **New Job**.
The **Job Settings** screen is displayed.
4. Make job settings on the **Job Settings** screen.
 - Job Name:** Enter the name of the job you want to register.
 - Scan Settings:** Make scan settings such as the size of the originals or the resolution.
 - Save Settings:** Set the saving destination, the saving format, the naming rules of the files, and so on.
 - Destination Settings:** Select the destination of the scanned images.
5. Click **OK** to return to the **Job List** screen.
The created job is registered in the **Job List**.
6. Click **OK** to return to the top screen.

Creating and Registering a Job (Mac OS)

Note:

Operations may vary depending on the operating system and the software version. See the software help for details on using the features.

1. Start Document Capture.
2. Click the  icon on the main window.
The **Job List** window is displayed.
3. Click the + icon.
The **Job Settings** window is displayed.
4. Make the job settings on the **Job Settings** window.
 - Job Name:** Enter the name of the job to register.
 - Scan:** Make the scan settings such as the size of the originals or the resolution.
 - Output:** Set the saving destination, the saving format, the naming rules of the files, and so on.
 - Destination:** Select the destination of the scanned images.
5. Click **OK** to return to the **Job List** window.
The job created is to be registered in the **Job List**.
6. Click **OK** to return to the main window.

Scanning

Set the Computer Name to Display on the Printer's Control Panel

You can set the computer name (alphanumeric) to display on the printer's control panel using Document Capture Pro.

Note:

Operations may vary depending on the operating system and the software version. See the software help for details on using the features.

1. Start Document Capture Pro.
2. On the menu bar of the main screen, select **Option > Network Scanning Settings**.

Note:

*On windows, **Option** is only displayed in standard view. If you are in simple view, click **Switch to Standard View**.*

3. On the **Network Scanning Settings** screen, enter the computer name in **Your PC Name (alphanumeric)**.
4. Click **OK**.

Setting Operation Mode

Before scanning, set the operation mode on the control panel to match the computer on which Document Capture Pro is installed.

1. Select **Settings** from the home screen.
2. Select **General Settings > Scan Settings > Document Capture Pro**.
3. Select the operation mode.
 - Client Mode:** Select this if Document Capture Pro is installed on Windows or Mac OS.
 - Server Mode:** Select this if Document Capture Pro is installed on a Windows Server. Next, enter the server address.
4. If you have changed the operation mode, check that the settings are correct, and then select **OK**.

Scanning Using the Document Capture Pro Settings

Before scanning, prepare the followings.

- Install Document Capture Pro on your computer (server) and create the job.
- Connect the printer and the computer (server) to the network.
- Set the operation mode on the control panel.

1. Place the originals.

Note:

If you want to scan multiple originals or make 2-sided scans, place all of the originals in the ADF.

2. Select **Scan** on the home screen.
3. Select **Computer**.

Scanning

4. Select **Select Computer.**, and then select the computer on which you created the job in Document Capture Pro.

Note:

- ❑ *The printer's control panel displays up to 100 computers on which Document Capture Pro is installed.*
- ❑ *If you have selected **Option > Network Scanning Settings**, and enabled **Protect with password** in Document Capture Pro or Document Capture, enter a password.*
- ❑ *If **Server Mode** is set as the operation mode, you do not need to perform this step.*

5. Select **Select Job.**, and then select the job.

Note:

- ❑ *If you have selected **Protect with password** in the settings in Document Capture Pro Server, enter a password.*
- ❑ *If you have set only one job, you do not need to select the job. Proceed to the next step.*

6. Select the area in which the job content is displayed, and then check the job details.

7. Tap .

Related Information

- ➔ [“Placing Originals” on page 39](#)

Scanning to a Memory Device

You can save the scanned image to a memory device.

1. Insert a memory device into the printer's external interface USB port.

2. Place the originals.

Note:

If you want to scan multiple originals or make 2-sided scans, place all of the originals in the ADF.

3. Select **Scan** on the home screen.

4. Select **Memory Device**.

5. Set items on **Basic Settings** such as the save format.

6. Select **Advanced**, and then check settings, and change them if necessary.

Note:

Select  to save your settings as a preset.

7. Tap .

Related Information

- ➔ [“Placing Originals” on page 39](#)
- ➔ [“Registering Your Favorite Settings as a Preset” on page 55](#)

Basic Menu Options for Scanning to a Memory Device

Note:

The items may not be available depending on other settings you made.

B&W/Color:

Select whether to scan in color or in monochrome.

File Format:

Select the format in which to save the scanned image.

 Compression Ratio

Select how much to compress the scanned image.

 PDF Settings

When you have selected **PDF** as the save format setting, use these settings to protect PDF files.

To create a PDF file that requires a password when opening, set **Document Open Password**. To create a PDF file that requires a password when printing or editing, set **Permissions Password**.

Resolution:

Select the scanning resolution.

2-Sided:

Scan both sides of the original.

 Orientation (Original)

Select the orientation of the original.

 Binding(Original)

Select the binding direction of the original.

Scan Area:

Select the scan area. To crop the white space around the text or image when scanning, select **Auto Cropping**. To scan at the maximum area of the scanner glass, select **Max Area**.

 Orientation (Original)

Select the orientation of the original.

Original Type:

Select the type of your original.

Advanced Menu Options for Scanning to a Memory Device

Note:

The items may not be available depending on other settings you made.

Density:

Select the contrast of the scanned image.

Remove Shadow:

Remove the shadows of the original that appear in the scanned image.

Scanning

 Surround

Remove the shadows at the edge of the original.

 Center

Remove the shadows of the binding margin of the booklet.

Remove Punch Holes:

Remove the punch holes that appear in the scanned image. You can specify the area to erase the punch holes by entering a value in the box on the right.

 Erasing Position

Select the position to remove the punch holes.

 Orientation (Original)

Select the orientation of the original.

File Name:

 Filename Prefix

Enter a prefix for the name of the images in alphanumeric characters and symbols.

 Add Date

Add the date to the file name.

 Add Time

Add the time to the file name.

Scanning to the Cloud

You can send scanned images to cloud services. Before using this feature, make settings using Epson Connect. See the following Epson Connect portal website for details.

<https://www.epsonconnect.com/>

<http://www.epsonconnect.eu> (Europe only)

1. Make sure that you have made settings using Epson Connect.
2. Place the originals.

Note:

If you want to scan multiple originals or make a 2-sided scan, place all of the originals on the ADF.

3. Select **Scan** on the home screen.
4. Select **Cloud**.
5. Select  on the top of the screen, and then select a destination.
6. Set items on **Basic Settings** such as the save format.
7. Select **Advanced**, and then check settings, and change them if necessary.

Note:

Select  to save your settings as a preset.

Scanning

8. Tap .

Related Information

➔ [“Placing Originals” on page 39](#)

Basic Menu Options for Scanning to the Cloud

Note:

The items may not be available depending on other settings you made.

B&W/Color:

Select whether to scan in color or in monochrome.

JPEG/PDF:

Select the format in which to save the scanned image.

2-Sided:

Scan both sides of the original.

Orientation (Original)

Select the orientation of the original.

Binding(Original)

Select the binding direction of the original.

Scan Area:

Select the scan area. To crop the white space around the text or image when scanning, select **Auto Cropping**. To scan at the maximum area of the scanner glass, select **Max Area**.

Orientation (Original)

Select the orientation of the original.

Advanced Menu Options for Scanning to the Cloud

Note:

The items may not be available depending on other settings you made.

Original Type:

Select the type of your original.

Density:

Select the contrast of the scanned image.

Remove Shadow:

Remove the shadows of the original that appear in the scanned image.

Surround

Remove the shadows at the edge of the original.

Scanning

- Center

Remove the shadows of the binding margin of the booklet.

Remove Punch Holes:

Remove the punch holes that appear in the scanned image. You can specify the area to erase the punch holes by entering a value in the box on the right.

- Erasing Position

Select the position to remove the punch holes.

- Orientation (Original)

Select the orientation of the original.

Scanning Using WSD

Note:

This feature is only available for computers running Windows 10/Windows 8.1/Windows 8/Windows 7/Windows Vista.

If you are using Windows 7/Windows Vista, you need to setup your computer in advance using this feature.

1. Place the originals.

Note:

If you want to scan multiple originals, place all of the originals on the ADF.

2. Select **Scan** on the home screen.
3. Select **WSD**.
4. Select a computer.
5. Tap .

Setting Up a WSD Port

This section explains how to set up a WSD port for Windows 7/Windows Vista.

Note:

For Windows 10/Windows 8.1/Windows 8, the WSD port is set up automatically.

The following is necessary to set up a WSD port.

- The printer and the computer are connected to the network.
- The printer driver is installed on the computer.

1. Turn the printer on.
2. Click start, and then click **Network** on the computer.
3. Right-click the printer, and then click **Install**.
Click **Continue** when the **User Account Control** screen is displayed.

Scanning

Click **Uninstall** and start again if the **Uninstall** screen is displayed.

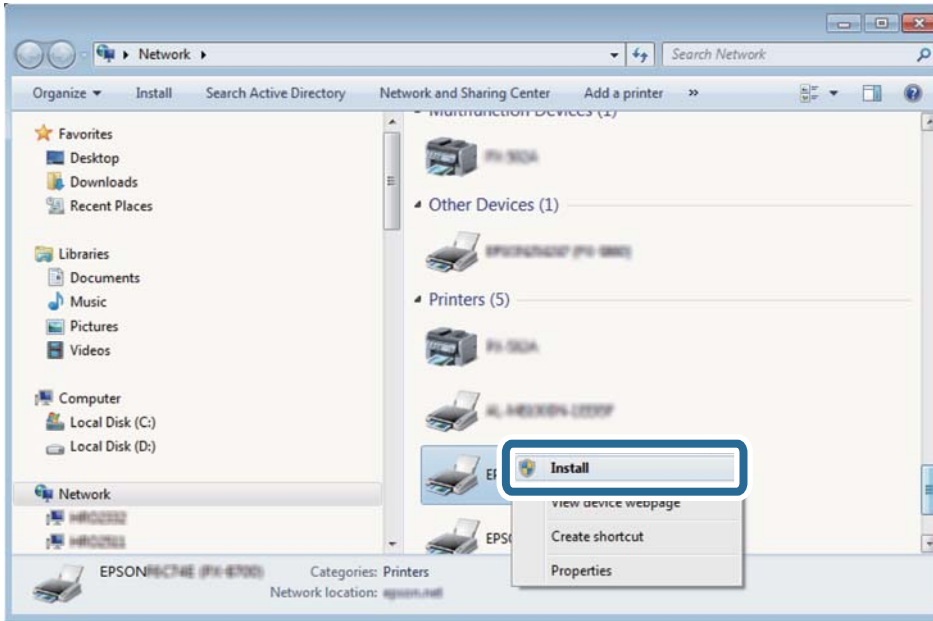

Note:

The printer name you set on the network and model name (EPSON XXXXXX (XX-XXXX)) are displayed on the network screen. You can check the printer's name set on the network from the printer's control panel or by printing a network status sheet.

4. Click **Your device is ready to use**.

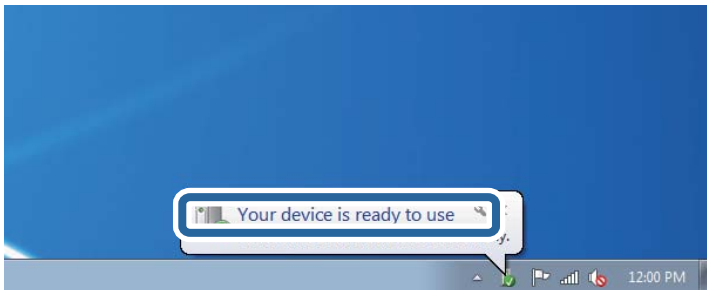

5. Check the message, and then click **Close**.

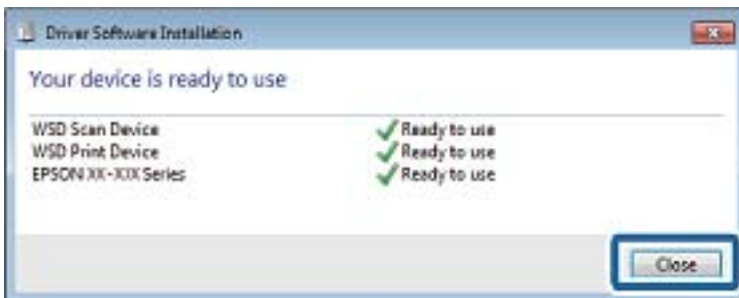

6. Open the **Devices and Printers** screen.

- ❑ Windows 7

Click start > **Control Panel** > **Hardware and Sound** (or **Hardware**) > **Devices and Printers**.

Scanning

- ❑ Windows Vista

Click start > **Control Panel** > **Hardware and Sound** > **Printers**.

7. Check that an icon with the printer's name on the network is displayed.
Select the printer name when using with WSD.

Scanning from a Computer

Authenticating Users on Epson Scan 2 when Using Access Control

When the access control function is enabled for a printer, you need to register a user name and password when scanning using Epson Scan 2. If you do not know the password, contact your printer administrator.

1. Start Epson Scan 2.
2. On the Epson Scan 2 screen, make sure that your printer is selected in the **Scanner** list.
3. Select **Settings** from the **Scanner** list to open the **Scanner Settings** screen.
4. Click **Access Control**.
5. On the **Access Control** screen, enter the **User Name** and the **Password** for an account that has permission to scan.
6. Click **OK**.

Scanning Using Epson Scan 2

You can scan using the scanner driver "Epson Scan 2". You can scan originals using detailed settings that are suitable for text documents.

See the Epson Scan 2 help for an explanation of each setting item.

1. Place the original.

Note:

If you want to scan multiple originals, place them in the ADF.

2. Start Epson Scan 2.

Scanning

3. Make the following settings on the **Main Settings** tab.

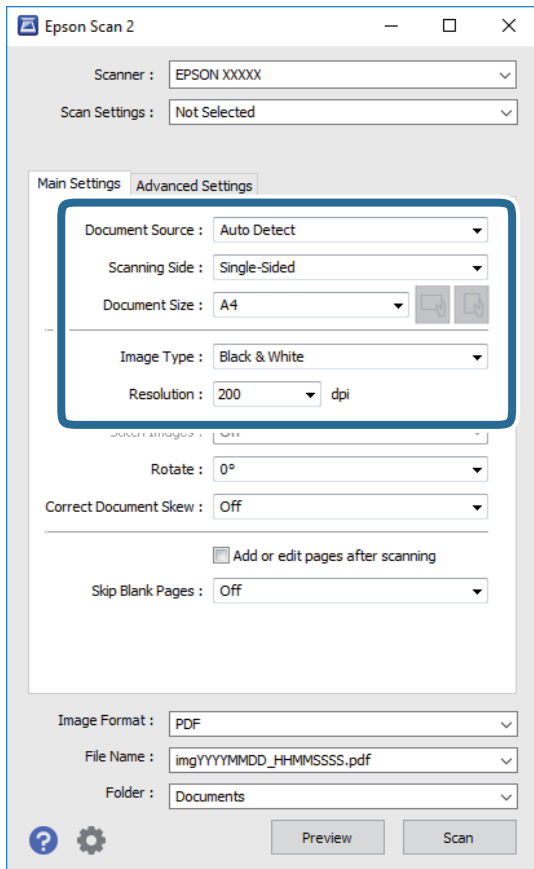

- Document Source: Select the source where the original is placed.
- Scanning Side: Select the side of the original you want to scan when scanning from ADF.
- Document Size: Select the size of the original you placed.
-  (Original orientation) buttons: Select the set orientation of the original you placed. Depending on the size of the original, this item may be set automatically and cannot be changed.
- Image Type: Select the color for saving the scanned image.
- Resolution: Select the resolution.

4. Make other scan settings if necessary.

- You can preview the scanned image by clicking the **Preview** button. The preview window opens, and the previewed image is displayed.
When you preview using the ADF, the original is ejected from the ADF. Place the ejected original again.

Scanning

- ❑ On the **Advanced Settings** tab, you can make detailed image adjustment settings that are suitable for text documents, such as the following.
 - ❑ **Remove Background:** Remove the background of the originals.
 - ❑ **Text Enhancement:** You can make blurred letters in the original clear and sharp.
 - ❑ **Auto Area Segmentation:** You can make letters clear and images smooth when performing black and white scanning for a document that contains images.
 - ❑ **Color Enhance:** You can enhance the color specified for the scanned image, and then save it in grayscale or black and white.
 - ❑ **Threshold:** You can adjust the border for monochrome binary (black and white).
 - ❑ **Unsharp Mask:** You can enhance and sharpen the outlines of the image.
 - ❑ **Descreening:** You can remove moiré patterns (web-like shadows) that appear when scanning printed papers such as a magazine.
 - ❑ **Edge Fill:** You can remove the shadow created around the scanned image.
 - ❑ **Dual Image Output (Windows Only):** You can scan once and save two images with different output settings at the same time.

Note:

The items may not be available depending on other settings you made.

5. Set the file saving settings.

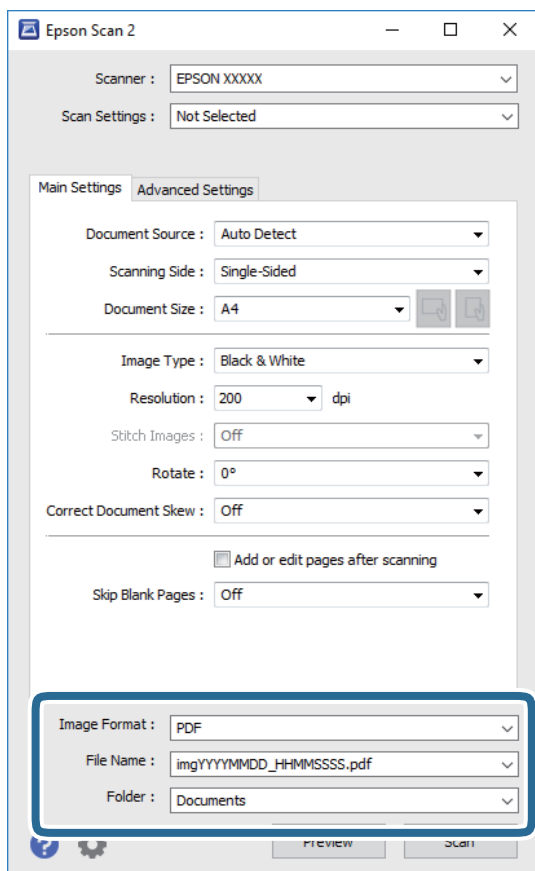

Scanning

- Image Format:** Select the save format from the list.

You can make detailed settings for each save format except BITMAP and PNG. Select **Options** from the list after selecting the save format.

- File Name:** Confirm the save file name displayed.

You can change settings for the file name by selecting **Settings** from the list.

- Folder:** Select the save folder for the scanned image from the list.

You can select another folder or create a new folder by selecting **Select** from the list.

6. Click **Scan**.

Related Information

➔ [“Placing Originals” on page 39](#)

➔ [“Application for Scanning Documents and Images \(Epson Scan 2\)” on page 238](#)

Scanning from Smart Devices

Epson iPrint is an application that allows you to scan photos and documents from a smart device, such as a smartphone or tablet, that is connected to the same wireless network as your printer. You can save the scanned data on a smart device or to Cloud services, send it by email, or print it.

If you start Epson iPrint when the printer is not connected to the network, a message is displayed instructing you to connect to the printer. Follow the instructions to complete the connection. See the URL below for the operating conditions.

<http://epson.sn>



Installing Epson iPrint

You can install Epson iPrint on your smart device from the following URL or QR code.

<http://ipr.to/c>



Scanning Using Epson iPrint

Start Epson iPrint from your smart device and select the item you want to use from the home screen.

Scanning

The following screens are subject to change without notice.



1	Home screen displayed when the application is started.
2	Displays information on how to setup the printer and a FAQ.
3	Displays the screen where you can select the printer and make printer settings. Once you have selected the printer, you do not need to select it again from the next time.
4	Displays the scanning screen.
5	Displays the screen where you can make scan settings such as resolution.
6	Displays scanned images.
7	Starts scanning.
8	Displays the screen where you can save scanned data to a smart device or Cloud services.
9	Displays the screen where you can send scanned data by email.
10	Displays the screen where you can print scanned data.

Faxing

Before Using Fax Features

Check the following before you start using the fax features.

- The printer and the phone line, and (if necessary) the phone machine are connected correctly
- Fax basic settings (Fax Setting Wizard) is complete
- Other necessary Fax Settings are complete

If your organization has a printer administrator, contact your administrator to check the status or conditions of the connection and settings.

See "Related Information" below to make settings.

Related Information

- ➔ ["Fax Settings" on page 70](#)

Sending Faxes Using the Printer

Sending Faxes Using the Control Panel

Related Information

- ➔ ["Sending Faxes Automatically Using the Control Panel" on page 191](#)
- ➔ ["Sending Faxes Manually After Confirming the Recipient's Status" on page 193](#)

Sending Faxes Automatically Using the Control Panel

You can send faxes by entering fax numbers for recipients on the control panel.

Note:

- When sending a fax in monochrome, you can preview the scanned image on the LCD screen before sending.
- You can reserve up to 50 monochrome fax jobs even while the phone line is in use for a voice call, sending another fax, or receiving a fax. You can check or cancel reserved fax jobs from .

1. Place the originals.

You can send up to 100 pages in one transmission; however depending on the remaining amount of memory, you may not be able to send faxes even with less than 100 pages.

2. Select **Fax** on the home screen.

Faxing

3. Specify the recipient.

You can send the same monochrome fax to up to 200 recipients. However, a color fax can only be sent to one recipient at a time.

- ❑ To enter manually: Select **Keypad**, enter a fax number on the screen displayed, and then tap **OK**.
 - To add a pause (pause for three seconds during dialing), enter a hyphen(-).
 - If you have set an external access code in **Line Type**, enter "#" (hash) instead of the actual external access code at the beginning of the fax number.

Note:

If you cannot manually enter a fax number, **Direct Dialing Restrictions** in **Security Settings** is set to **On**. Select fax recipients from the contacts list or the sent fax history.

- ❑ To select from the contacts list: Select **Contacts** and select recipients you want to send. If the recipient you want to send to has not been registered in **Contacts** yet, tap  to register it.
- ❑ To select from the sent fax history: Select **Recent**, and then select a recipient.
- ❑ To select from the list on the **Recipient** tab: Select a recipient from the list registered in **Settings > Contacts Manager > Frequent**.

Note:



To delete recipients you entered, display the list of recipients by tapping on the field of a fax number or the number of recipients on the LCD screen, select the recipient from the list, and then select **Remove**.

4. Select the **Fax Settings** tab, and then make settings such as the resolution and the sending method as necessary.



Note:



- ❑ To send 2-sided originals, enable **ADF 2-Sided**. You can send them in monochrome. You cannot send in color with this setting.
- ❑ Tap  (**Presets**) on the fax top screen to save the current settings and the recipients in **Presets**. Recipients may not be saved depending on how you specified the recipients, such as entering a fax number manually.

5. Send the fax.

- ❑ To send without checking the scanned document image: Tap .
- ❑ To scan, check the scanned document image, and then send (when sending a fax in monochrome only): Tap  on the fax top screen. To send the fax as is, select **Start Sending**. Otherwise, select **Cancel**, and then go to step 3.

-     : Moves the screen in the direction of the arrows.

-   : Reduces or enlarges.

-   : Moves to the previous or the next page.

Note:

- ❑ You cannot send the fax in color after previewing.
- ❑ When **Direct Send** is enabled, you cannot preview.
- ❑ When the preview screen is left untouched for 20 seconds, the fax is sent automatically.
- ❑ The image quality of a sent fax may be different from what you previewed depending on the capability of the recipient machine.

Faxing

- When sending is complete, remove the originals.

Note:



- ❑ *If the fax number is busy or there is some problem, the printer automatically redials after one minute.*
- ❑ *To cancel sending, tap .*
- ❑ *It takes longer to send a fax in color because the printer performs scanning and sending simultaneously. While the printer is sending a fax in color, you cannot use the other features.*

Related Information

- ➔ [“Managing Contacts” on page 49](#)
- ➔ [“Registering Your Favorite Settings as a Preset” on page 55](#)
- ➔ [“Placing Originals” on page 39](#)
- ➔ [“Menu Options for Faxing” on page 206](#)
- ➔ [“Checking the Status or Logs for Fax Jobs” on page 214](#)

Sending Faxes Manually After Confirming the Recipient's Status

You can send a fax while listening to sounds or voices through the printer's speaker while dialing, communicating, and transmitting.

- Place the originals.
- Select **Fax** on the home screen.
You can send up to 100 pages in one transmission.
- Select the **Fax Settings** tab, and then make settings such as the resolution and the sending method as necessary. When you have finished making settings, select the **Recipient** tab.
- Tap  and then specify the recipient.
Note:
You can adjust the sound volume of the speaker.
- When you hear a fax tone, select **Send/Receive** at the upper right corner of the LCD screen, and then select **Send**.
Note:
When receiving a fax from a fax polling service, and you hear the audio guidance, follow the guidance to make the printer operations.
- Tap .
- When sending is complete, remove the originals.

Related Information

- ➔ [“Placing Originals” on page 39](#)
- ➔ [“Menu Options for Faxing” on page 206](#)

Faxing

Sending Faxes Dialing from the External Phone Device

You can send a fax by dialing using the connected telephone when you want to talk over the phone before sending a fax, or when the recipient's fax machine does not switch to the fax automatically.

1. Place the originals.

You can send up to 100 pages in one transmission.

2. Pick up the handset of the connected telephone, and then dial the recipient's fax number using the phone.

Note:

When the recipient answers the phone, you can talk with the recipient.

3. Select **Fax** on the home screen.

4. Select the **Fax Settings** tab, and then make settings such as the resolution and the sending method as necessary.

5. When you hear a fax tone, tap , and then hang up the handset.

Note:

When a number is dialed using the connected telephone, it takes longer to send a fax because the printer performs scanning and sending simultaneously. While sending the fax, you cannot use the other features.

6. When sending is complete, remove the originals.

Related Information

- ➔ [“Placing Originals” on page 39](#)
- ➔ [“Fax Settings” on page 206](#)

Sending Faxes On Demand (Using Polling Send/Bulletin Board Box)

If you store a monochrome document which has up to 100 pages in the **Polling Send** box or one of the bulletin board boxes, the stored document can be sent upon request from another fax machine that has a polling receive feature.

You can store one document in the **Polling Send** box.

You can register up to 10 bulletin boards, and store one document in each registered bulletin board. Note that the fax machine of the recipient must support the subaddress/password feature.

Related Information

- ➔ [“Setting the Polling Send Box” on page 194](#)
- ➔ [“Registering a Bulletin Board Box” on page 195](#)
- ➔ [“Storing a Document in the Polling Send/Bulletin Board Box” on page 196](#)
- ➔ [“Sending a Fax with a Subaddress\(SUB\) and Password\(SID\)” on page 199](#)

Setting the Polling Send Box

You can store a document in the **Polling Send Box** without registering. Make the following settings as necessary.

Faxing

1. Select **Fax Box > Polling Send/Board** from the home screen.

2. Select **Polling Send**, tap , and then select **Settings**.

Note:

If a password entry screen is displayed, enter the password.

3. Make the appropriate settings, such as **Notify Send Result**.

Note:

*If you set a password in **Box Open Password**, you will be asked to enter the password from the next time you open the box.*

4. Select **OK**.

Related Information

➔ [“Storing a Document in the Polling Send/Bulletin Board Box” on page 196](#)

➔ [“Polling Send/Board” on page 212](#)

Registering a Bulletin Board Box

You must register a bulletin board box for storing a document beforehand. Follow the steps below to register the box.

1. Select **Fax Box > Polling Send/Board** from the home screen.

2. Select one of the boxes named **Unregistered Bulletin Board**.

Note:

If a password entry screen is displayed, enter the password.

3. Make settings for the items on the screen.

Enter a name in **Name (Required)**

Enter a subaddress in **Subaddress(SEP)**

Enter a password in **Password(PWD)**

4. Make the appropriate settings such as **Notify Send Result**.

Note:

*If you set a password in **Box Open Password**, you will be asked to enter the password from the next time you open the box.*

5. Select **OK**.

To display the screen for changing settings or deleting registered boxes, select the box you want to change/delete, and then tap .

Related Information

➔ [“Storing a Document in the Polling Send/Bulletin Board Box” on page 196](#)

➔ [“Polling Send/Board” on page 212](#)

Faxing

Storing a Document in the Polling Send/Bulletin Board Box

1. Select **Fax Box** on the home screen, and then select **Polling Send/Board**.
2. Select **Polling Send** or one of the bulletin board boxes that have already been registered.
If the password entry screen is displayed, enter the password to open the box.
3. Tap **Add Document**.
4. On the fax top screen that is displayed, check the fax settings, and then tap  to scan and store the document.

To check the document you stored, select **Fax Box > Polling Send/Board**, select the box containing the document you want to check, and then tap **Check Document**. On the screen that is displayed, you can view, print or delete the scanned document.

Related Information

- ➔ [“Placing Originals” on page 39](#)
- ➔ [“Polling Send/Board” on page 212](#)
- ➔ [“Checking the Status or Logs for Fax Jobs” on page 214](#)

Various Ways of Sending Faxes

Related Information

- ➔ [“Sending Many Pages of a Monochrome Document \(Direct Send\)” on page 196](#)
- ➔ [“Sending a Fax Preferentially \(Priority Send\)” on page 197](#)
- ➔ [“Sending Faxes in Monochrome at a Specified Time \(Send Fax Later\)” on page 197](#)
- ➔ [“Sending Different Size Documents Using ADF \(Continuous Scan\(ADF\)\)” on page 198](#)
- ➔ [“Sending a Fax with a Subaddress\(SUB\) and Password\(SID\)” on page 199](#)
- ➔ [“Sending the Same Documents Multiple Times” on page 199](#)

Sending Many Pages of a Monochrome Document (Direct Send)

When sending a fax in monochrome, the scanned document is temporarily stored in the printer's memory. Therefore, sending a lot of pages may cause the printer to run out of memory and stop sending the fax. You can avoid this by enabling the **Direct Send** feature, however, it takes longer to send the fax because the printer performs scanning and sending simultaneously. You can use this feature when there is only one recipient.

1. Place the originals.
2. Select **Fax** on the home screen.
3. Specify the recipient.
4. Select the **Fax Settings** tab, and then tap **Direct Send** to set this to **On**.
You can also make settings such as the resolution and the sending method as necessary.
5. Send the fax.

Faxing

Related Information

- ➔ [“Placing Originals” on page 39](#)
- ➔ [“Sending Faxes Automatically Using the Control Panel” on page 191](#)
- ➔ [“Fax Settings” on page 206](#)

Sending a Fax Preferentially (Priority Send)

You can send an urgent document ahead of the other faxes waiting to be sent.

Note:

You cannot send your document preferentially while one of the following is in progress because the printer cannot accept another fax.

- Sending a monochrome fax with **Direct Send** enabled*
- Sending a color fax*
- Sending a fax using a connected telephone*
- Sending a fax sent from the computer*

1. Place the originals.
2. Select **Fax** on the home screen.
3. Specify the recipient.
4. Select the **Fax Settings** tab, and then tap **Priority Send** to set this to **On**.
You can also make settings such as the resolution and the sending method as necessary.
5. Send the fax.

Related Information

- ➔ [“Placing Originals” on page 39](#)
- ➔ [“Sending Faxes Automatically Using the Control Panel” on page 191](#)
- ➔ [“Fax Settings” on page 206](#)
- ➔ [“Checking the Status or Logs for Fax Jobs” on page 214](#)

Sending Faxes in Monochrome at a Specified Time (Send Fax Later)

You can set to send a fax at a specified time. Only monochrome faxes can be sent when the time to send is specified.

1. Place the originals.
2. Select **Fax** on the home screen.
3. Specify the recipient.
4. Make settings to send faxes at a specified time.
 - ❶ Select the **Fax Settings** tab, and then select **Send Fax Later**

Faxing

- 2 Tap **Send Fax Later** to set this to **On**.
- 3 Tap the **Time** box, enter the time you want to send the fax, and then select **OK**.
- 4 Select **OK** to apply the settings.

You can also make settings such as the resolution and the sending method as necessary.

5. Send the fax.

Note:

To cancel the fax, cancel it from .

Related Information

- ➔ [“Placing Originals” on page 39](#)
- ➔ [“Sending Faxes Automatically Using the Control Panel” on page 191](#)
- ➔ [“Fax Settings” on page 206](#)
- ➔ [“Checking the Status or Logs for Fax Jobs” on page 214](#)

Sending Different Size Documents Using ADF (Continuous Scan(ADF))

Sending faxes by placing originals one by one, or by placing originals by size, you can send them as one document at their original sizes.

If you place different sized originals in the ADF, all of the originals are sent at the largest size among them. To send originals at their original sizes, do not place originals with mixed sizes.

1. Place the first batch of originals at the same size.
2. Select **Fax** on the home screen.
3. Specify the recipient.
4. Select the **Fax Settings** tab, and then tap **Continuous Scan(ADF)** to set this to **On**.

You can also make settings such as the resolution and the sending method as necessary.

5. Tap  (**Send**).
6. When scanning the first originals is complete and the message **Scan complete. Scan the next page?** is displayed on the control panel, select **Yes**, set the next originals, and then select **Start Scanning**.

Note:

If you leave the printer untouched for 20 seconds after prompted to set the next originals, the printer stops storing and starts sending the document.

Related Information

- ➔ [“Placing Originals” on page 39](#)
- ➔ [“Sending Faxes Automatically Using the Control Panel” on page 191](#)
- ➔ [“Fax Settings” on page 206](#)

Faxing

Sending a Fax with a Subaddress(SUB) and Password(SID)

You can send faxes to the confidential boxes or the relay boxes in the recipient's fax machine when the recipient's fax machine has the feature to receive confidential faxes or relay faxes. The recipients can receive them securely, or can forward them to specified fax destinations.

1. Place the originals.
2. Select **Fax** on the home screen.
3. Select **Contacts** and select a recipient with a registered subaddress and password.
You can also select the recipient from **Recent** if it was sent with a subaddress and password.
4. Select the **Fax Settings** tab, and then make settings such as the resolution and the sending method as necessary.
5. Send the fax.

Related Information

- ➔ [“Managing Contacts” on page 49](#)
- ➔ [“Placing Originals” on page 39](#)
- ➔ [“Sending Faxes Automatically Using the Control Panel” on page 191](#)
- ➔ [“Fax Settings” on page 206](#)

Sending the Same Documents Multiple Times

Related Information



- ➔ [“Storing a Fax Without Specifying a Recipient \(Store Fax Data\)” on page 199](#)
- ➔ [“Sending Faxes Using the Stored Document Feature” on page 200](#)

Storing a Fax Without Specifying a Recipient (Store Fax Data)

Since you can send faxes using documents stored in the printer, you can save the time spent scanning documents when you need to send the same document frequently. You can store up to 100 pages of a single document in monochrome. You can store 10 documents in the printer's stored documents box.

Note:

Saving 10 documents may not be possible depending on the usage conditions such as the file size of stored documents.

1. Place the originals.
2. Select **Fax Box** on the home screen.
3. Select **Stored Documents**, tap  (Box Menu), and then select **Store Fax Data**.
4. In the **Fax Settings** tab that is displayed, make settings such as the resolution as necessary.
5. Tap  to store the document.

Faxing

After storing a document is complete, you can preview the scanned image by selecting **Fax Box > Stored**

Documents and then tapping the box for the document, or you can delete it by tapping  on the right of the box for the document.

Related Information

- ➔ [“Placing Originals” on page 39](#)
- ➔ [“Stored Documents” on page 211](#)
- ➔ [“Checking the Status or Logs for Fax Jobs” on page 214](#)

Sending Faxes Using the Stored Document Feature

1. Select **Fax Box** on the home screen, and then select **Stored Documents**.
2. Select the document you want to send, check the content of the document, and then select **Start Sending**.
When the message **Delete this document after sending?** is displayed, select **Yes** or **No**.
3. Specify the recipient.
4. Select the **Fax Settings** tab, and then make settings such as the sending method as necessary.
5. Tap .

Related Information

- ➔ [“Stored Documents” on page 211](#)

Receiving Faxes on the Printer

If the printer is connected to the phone line and basic settings have been completed using the Fax Setting Wizard, you can receive faxes.

There are two ways of receiving faxes.

- Receiving an incoming fax
- Receiving a fax by making a call (Polling Receive)

Received faxes are printed in the printer's initial settings.

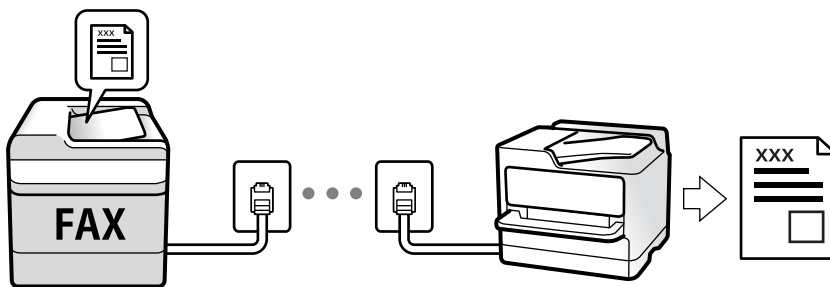

You can save received faxes, check them on the printer screen, and forward them.

Faxing

To check the status of the fax settings, you can print a **Fax Settings List** by selecting **Fax** >  (More) > **Fax Report** > **Fax Settings List**.

See "Related Information" below to make settings.

Related Information

➔ [“Making Settings Individually for Printer's Fax Features” on page 76](#)

Receiving Incoming Faxes

There are two options in **Receive Mode**.

Related Information

➔ [“Usage of Auto Mode” on page 201](#)

➔ [“Usage of Manual Mode” on page 201](#)

Usage of Manual Mode

This mode is mainly for making phone calls, but is also for faxing.

Receiving Faxes

When the telephone rings, you can answer the ringing manually by picking up the handset.

When you hear a fax signal (baud):

Select **Fax** on the printer's home screen, select **Send/Receive** > **Receive**, and then tap . Next, hang up the handset.

If the ringing is for a voice call:

You can answer the phone as normal.

Receiving Faxes Using only the Connected Telephone

When **Remote Receive** is set, you can receive faxes by simply entering the **Start Code**.

When the telephone rings, pick up the handset. When you hear a fax tone (baud), dial the two digit **Start Code**, and then hang up the handset. If your organization has a printer administrator and you do not know the start code, contact the administrator.

Usage of Auto Mode

This mode allows you to use the line for the following uses.

Using the line for faxing only (external telephone is not necessary)

Using the line for faxing mainly, and sometimes phoning

Receiving Faxes Without an External Phone Device

The printer automatically switches to receive faxes when the number of rings you set in **Rings to Answer** is complete.

Faxing

Receiving Faxes With an External Phone Device

A printer with an external phone device works as follows.

- ❑ When the answering machine answers within the number of rings set in **Rings to Answer**:
 - If the ringing is for a fax: The printer automatically switches to receive faxes.
 - If the ringing is for a voice call; The answering machine can receive voice calls and record voice messages.
- ❑ When you pick up the handset within the number of rings set in **Rings to Answer**:
 - If the ringing is for a fax: You can receive the fax using the same steps as for **Manual**. Select **Fax** on the home screen, and then select **Send/Receive > Receive**. Next, select , and then hang up the handset.
 - If the ringing is for a voice call: You can answer the phone as normal.
- ❑ When the ringing stops and the printer automatically switches to receive faxes:
 - If the ringing is for a fax: The printer starts receiving faxes.
 - If the ringing is for a voice call: You cannot answer the phone. Ask the person to call you back.

Note:

Set the number of rings to answer for the answering machine to a lower number than the number set in **Rings to Answer**. Otherwise, the answering machine cannot receive voice calls to record voice messages. For details on setting up the answering machine, see the manual supplied with the answering machine.

Related Information

➔ [“Usage of Manual Mode” on page 201](#)

Receiving Faxes by Making a Phone Call

You can receive a fax stored on another fax machine by dialing the fax number.

Related Information

➔ [“Receiving Faxes by Polling \(Polling Receive\)” on page 202](#)

➔ [“Receiving Faxes from a Board with a Subaddress \(SEP\) and Password \(PWD\) \(Polling Receive\)” on page 203](#)

Receiving Faxes by Polling (Polling Receive)

You can receive a fax stored on another fax machine by dialing the fax number. Use this feature to receive a document from a fax information service.

Note:

- ❑ If the fax information service has an audio guidance feature that you need to follow to receive a document, you cannot use this feature.
- ❑ To receive a document from a fax information service that uses audio guidance, just dial the fax number using the **On Hook** feature or the connected telephone, and operate the phone and the printer following the audio guidance.

1. Select **Fax** on the home screen.
2. Tap  (More).
3. Select **Extended Fax**.

Faxing

4. Tap the **Polling Receive** box to set this to **On**.
5. Tap **Close**, and then tap **Close** again.
6. Enter the fax number.

Note:

If you cannot manually enter a fax number, **Direct Dialing Restrictions** in **Security Settings** is set to **On**. Select fax recipients from the contacts list or the sent fax history.

7. Tap .

Related Information

- ➔ [“Sending Faxes Dialing from the External Phone Device” on page 194](#)
- ➔ [“Receiving Faxes After Confirming the Sender's Status” on page 203](#)
- ➔ [“More” on page 208](#)

Receiving Faxes After Confirming the Sender's Status

You can receive a fax while listening to sounds or voices through the printer's speaker while dialing, communicating, and transmitting. You can use this feature when you want to receive a fax from a fax information service by following an audio guide.

1. Select **Fax** on the home screen.
2. Tap , and then specify the sender.

Note:

You can adjust the sound volume of the speaker.

3. Wait until the sender answers your call. When you hear a fax tone, select **Send/Receive** at the upper right corner of the LCD screen, and then select **Receive**.

Note:

When receiving a fax from a fax information service, and you hear the audio guidance, follow the guidance to make the printer operations.

4. Tap .

Receiving Faxes from a Board with a Subaddress (SEP) and Password (PWD) (Polling Receive)

By dialing to a sender, you can receive faxes from a board stored on sender's fax machine with a subaddress (SEP) and password (PWD) feature. To use this feature, register the contact with the subaddress (SEP) and password (PWD) in the contacts list in advance.

1. Select **Fax** on the home screen.
2. Select  (More).
3. Select **Extended Fax**.

Faxing

4. Tap **Polling Receive** to set this to **On**.
5. Tap **Close**, and then tap **Close** again.
6. Select **Contacts**, and then select the contact with the registered subaddress (SEP) and password (PWD) to match the destination board.
7. Tap .

Related Information

- ➔ [“Managing Contacts” on page 49](#)
- ➔ [“Sending Faxes Dialing from the External Phone Device” on page 194](#)
- ➔ [“Receiving Faxes After Confirming the Sender's Status” on page 203](#)
- ➔ [“More” on page 208](#)

Saving and Forwarding Received Faxes

Summary of the Features

If your organization has a printer administrator, contact your administrator to check the status of the printer settings.

Saving Received Faxes in the Printer

The received faxes can be saved in the printer, and you can view them on the printer's screen. You can print only the faxes you want to print or delete unnecessary faxes.

Saving and/or Forwarding Received Faxes to Destinations Other than the Printer

The following can be set as destinations.

- Computer (PC-FAX reception)
- External memory device
- Email address
- Shared folder on a network
- Another fax machine

Note:

- The fax data is saved as PDF format.*
- Color documents cannot be forwarded to another fax machine. They are processed as documents that failed to be forwarded.*

Sorting Received Faxes by Conditions such as Subaddress and Password

You can sort and save received faxes to your Inbox or bulletin board boxes. You can also forward received faxes to destinations other than the printer.

- Email address
- Shared folder on a network

Faxing

- Another fax machine

Note:

- The fax data is saved as PDF format.
- Color documents cannot be forwarded to another fax machine. They are processed as documents that failed to be forwarded.
- You can print the save/forward conditions set in the printer. Select **Fax** on the home screen, and then select  (More) > **Fax Report** > **Conditional Save/Forward list**.
- If your organization has a printer administrator, contact the administrator to set or change the save/forward conditions. See "Related Information" below to check or change settings.

Related Information

- ➔ [“Setting Saving and Forwarding to Receive Faxes \(Unconditional Save/Forward\)” on page 80](#)
- ➔ [“Setting Saving and Forwarding to Receive Faxes \(Conditional Save/Forward\)” on page 83](#)
- ➔ [“More” on page 208](#)
- ➔ [“Viewing Received Faxes Saved in the Printer on the LCD Screen” on page 205](#)

Viewing Received Faxes Saved in the Printer on the LCD Screen





1. Select **Fax Box** on the home screen.

Note:

When there are received faxes that have not been read, the number of unread documents is displayed on the  on the home screen.

2. Select **Inbox/Confidential**.
3. Select the inbox or the confidential box you want to view.
4. If the inbox, or the confidential box has been password protected, enter the inbox password, the confidential box password, or the administrator password.
5. Select the fax you want to view from the list.

The contents of the fax are displayed.

-  : Rotates the image to the right by 90 degrees.
-  : Moves the screen in the direction of the arrows.
-  : Reduces or enlarges.
-  : Moves to the previous or the next page.
-  : Displays menus such as save and forward.
- To hide the operation icons, tap anywhere on the preview screen except for the icons. Tap again to display the icons.

Faxing

6. Select whether to print or delete the document you have viewed, and then follow the on-screen instructions.



Important:

If the printer runs out of memory, receiving and sending faxes is disabled. Delete documents that you have already read or printed.

Related Information

➔ [“Inbox and Confidential Boxes” on page 209](#)

Menu Options for Faxing

Recipient

Select the menus on the control panel as described below:

Fax > Recipient

Keypad	Manually enter a fax number.
Contacts	Select a recipient from the contacts list. You can also add or edit a contact.
Recent	Select a recipient from the sent fax history. You can also add the recipient to the contacts list.

Fax Settings

Select the menus on the control panel as described below:

Fax > Fax Settings

Quick Operation Button

Assigning up to three frequently used items such as **Transmission Log** and **Original Type** in **Settings > General Settings > Fax Settings > Quick Operation Button**, displays the items at the top of the **Fax Settings** tab.

Scan Settings

Original Size (Glass)	Select the size and orientation of the original you placed on the scanner glass.
Original Type	Select the type of your original.
Color Mode	Select whether to scan in color or in monochrome.
Resolution	Select the resolution of the outgoing fax. If you select a higher resolution, the data size becomes larger and it takes time to send the fax.
Density	Sets the density of the outgoing fax. + makes the density darker, and - makes it lighter.
Remove Background	Detects the paper color (background color) of the original document, and removes or lightens the color. Depending on the darkness and vividness of the color, it may not be removed or lightened

Faxing

Sharpness	Enhances or defocuses the outline of the image. + enhances the sharpness, and - defocuses the sharpness.
ADF 2-Sided	Scans both sides of originals placed in the ADF and sends a monochrome fax.
Continuous Scan(ADF)	Sending faxes by placing originals one by one, or by placing originals by size, you can send them as one document at their original sizes. See the related information below on this topic.

Fax Send Settings

Direct Send	<p>Sends a monochrome fax while scanning the originals. Since scanned originals are not stored temporarily in the printer's memory even when sending a large volume of pages, you can avoid printer errors due to a lack of memory. Note that sending using this feature takes longer than not using this feature. See the related information below on this topic.</p> <p>You cannot use this feature when:</p> <ul style="list-style-type: none"> <input type="checkbox"/> Sending a fax using the ADF 2-Sided option <input type="checkbox"/> Sending a fax to multiple recipients
Priority Send	Sends the current fax before other faxes waiting to be sent. See the related information below on this topic.
Send Fax Later	Sends a fax at a time you specified. Only a monochrome fax is available when using this option. See the related information below on this topic.
Add Sender Information	<ul style="list-style-type: none"> <input type="checkbox"/> Add Sender Information <ul style="list-style-type: none"> Select the position where you want to include the header information (sender name and fax number) in the outgoing fax, or not to include the information. - Off: Sends a fax with no header information. - Outside of Image: Sends a fax with header information in the top white margin of the fax. This keeps the header from overlapping with the scanned image, however, the fax received by the recipient may be printed across two sheets depending on the size of the originals. - Inside of Image: Sends a fax with header information approximately 7 mm lower than the top of the scanned image. The header may overlap with the image, however, the fax received by the recipient will not be split into two documents. <input type="checkbox"/> Fax Header <ul style="list-style-type: none"> Select the header for the recipient. To use this feature, you should register multiple headers in advance. <input type="checkbox"/> Additional Information <ul style="list-style-type: none"> Select the information you want to add. You can select one from Your Phone Number and Destination List.
Notify Send Result	Sends a notification after you send a fax.
Transmission Report	<p>Prints a transmission report after you send the fax.</p> <p>Print on Error prints a report only when an error occurs.</p>
Backup	<p>Saves a backup of the sent fax that is scanned and saved to the printer's memory automatically. The backup feature is available when:</p> <ul style="list-style-type: none"> <input type="checkbox"/> Sending a fax in monochrome <input type="checkbox"/> Sending a fax using the Send Fax Later feature <input type="checkbox"/> Sending a fax using the Batch Send feature <input type="checkbox"/> Sending a fax using the Store Fax Data feature

Faxing

Related Information

- ➔ “Sending Different Size Documents Using ADF (Continuous Scan(ADF))” on page 198
- ➔ “Sending Many Pages of a Monochrome Document (Direct Send)” on page 196
- ➔ “Sending a Fax Preferentially (Priority Send)” on page 197
- ➔ “Sending Faxes in Monochrome at a Specified Time (Send Fax Later)” on page 197

More

Selecting  in **Fax** on the home screen displays the **More** menu.

Transmission Log

You can check the history of sent or received fax jobs.

Note that you can also check the history of sent or received fax jobs from **Job/Status**.

Fax Report

Last Transmission	Prints a report for the previous fax that was sent or received through polling.
Fax Log	Prints a transmission report. You can set to print this report automatically using the following menu. Settings > General Settings > Fax Settings > Report Settings > Fax Log Auto Print
Stored Fax Documents	Prints a list of fax documents stored in the printer's memory, such as unfinished jobs.
Fax Settings List	Prints the current fax settings.
Conditional Save/ Forward list	Prints the Conditional Save/Forward List.
Protocol Trace	Prints a detailed report for the previous fax that was sent or received.

Extended Fax

Polling Receive	When this is set to On and you call the sender's fax number, you can receive documents from the sender's fax machine. See the related information below for details on how to receive faxes using Polling Receive . When you leave the Fax menu, the setting returns to Off (default).
Polling Send/Board	When this is set to On by selecting the polling send box or a bulletin board box, you can scan and store documents to the box you selected by tapping  on the Fax Settings tab. You can store one document to the polling send box. You can store up to 10 documents to up to 10 bulletin boards in the printer, but you must register them from Fax Box before storing documents. See the related information below for details on how to register a bulletin board box. When you leave the Fax menu, the setting returns to Off (default).

Faxing

Store Fax Data	<p>When this is set to On, and you tap  on the Fax Settings tab, you can scan and store documents to the Stored Documents box. You can store up to 10 documents.</p> <p>You can also scan and save documents to the Stored Documents box from Fax Box. See the related information below for details on how to store documents from Fax Box</p> <p>When you leave the Fax menu, the setting returns to Off (default).</p>
----------------	---

Fax Box

Accesses the **Fax Box** on the home screen.

Fax Settings

Accesses **Settings > General Settings > Fax Settings**.

Related Information

- ➔ [“Receiving Faxes by Polling \(Polling Receive\)” on page 202](#)
- ➔ [“Setting the Polling Send Box” on page 194](#)
- ➔ [“Registering a Bulletin Board Box” on page 195](#)
- ➔ [“Storing a Document in the Polling Send/Bulletin Board Box” on page 196](#)
- ➔ [“Polling Send/Board” on page 212](#)
- ➔ [“Storing a Fax Without Specifying a Recipient \(Store Fax Data\)” on page 199](#)
- ➔ [“Stored Documents” on page 211](#)
- ➔ [“Checking the Status or Logs for Fax Jobs” on page 214](#)
- ➔ [“Checking the Fax Job History” on page 216](#)

Menu Options for Fax Box

Inbox/Confidential

You can find **Inbox/Confidential** in **Fax Box** on the home screen.

Inbox and Confidential Boxes

Inbox and confidential boxes are in **Fax Box > Inbox/Confidential**.

You can save up to 200 documents in the inbox and the confidential box in total.











You can use one Inbox and register up to 10 confidential boxes. The box name is displayed on the box. **Confidential XX** is the default name for each confidential box.

Inbox and Confidential Boxes

Displays the received faxes list by date received, sender name, and pages.

Tapping one of the faxes from the list opens the preview screen, and you can check the contents of the fax. You can print or delete the fax while you are previewing.

Faxing

<p>preview screen</p>	<ul style="list-style-type: none"> <input type="checkbox"/>   : Reduces or enlarges. <input type="checkbox"/>  : Rotates the image to the right by 90 degrees. <input type="checkbox"/>     : Moves the screen in the direction of the arrows. <input type="checkbox"/>   : Moves to the previous or the next page. <p>To hide the operation icons, tap anywhere on the preview screen except for the icons. Tap again to display the icons.</p>
<p> (Preview menu)</p>	<ul style="list-style-type: none"> <input type="checkbox"/> Save to Memory Device <input type="checkbox"/> Forward(Email) <input type="checkbox"/> Forward(Network Folder) <input type="checkbox"/> Send Fax <input type="checkbox"/> Details <p>When the message Delete When Complete is displayed, select On to delete faxes after completing processes such as Save to Memory Device or Forward(Email).</p>

 **(Box Menu)**

<p>Print All</p>	<p>This is displayed only when there are stored faxes in the box. Prints all faxes in the box. Selecting On in Delete When Complete deletes all faxes when printing is complete.</p>
<p>Save All to Memory Device</p>	<p>This is displayed only when there are stored faxes in the box. Saves all faxes to external memory devices in the box. Selecting On in Delete When Complete deletes all documents when saving is complete.</p>
<p>Delete All</p>	<p>This is displayed only when there are stored faxes in the box. Deletes all faxes in the box.</p>
<p>Settings</p>	<p>The following items are displayed when you select Inbox > Box Menu > Settings.</p> <ul style="list-style-type: none"> <input type="checkbox"/> Options when memory is full: Select one option to print or to decline incoming faxes after the Inbox is full. <input type="checkbox"/> Inbox Password Settings: You can set a password or change it. <p>The following items are displayed when you select a confidential box and select Box Menu > Settings.</p> <ul style="list-style-type: none"> <input type="checkbox"/> Name: Enter a name for the confidential box. <input type="checkbox"/> Box Open Password: You can set a password or change it.
<p>Delete Box</p>	<p>This item is displayed only when you select a confidential box and select Box Menu. Clears the current settings for Confidential Boxes and deletes all stored documents.</p>

Related Information

- ➔ [“Viewing Received Faxes Saved in the Printer on the LCD Screen” on page 205](#)
- ➔ [“More” on page 208](#)
- ➔ [“Checking the Fax Job History” on page 216](#)

Faxing

Stored Documents

You can find **Stored Documents** in **Fax Box** on the home screen.

You can store up to 100 pages of a single document in monochrome, and up to 10 documents in the box. This allows you to save time spent scanning documents when you need to send the same document frequently.











Note:

You may not be able to save 10 documents depending on the usage conditions such as the size of saved documents.

Stored Documents Box

Displays the stored documents list with stored dates and pages.

Tapping one of the stored documents from the list displays the preview screen. Tap **Start Sending** to go to the fax sending screen, or tap **Delete** to delete the document while you are previewing.

preview screen	<ul style="list-style-type: none"> <input type="checkbox"/>   : Reduces or enlarges. <input type="checkbox"/>  : Rotates the image to the right by 90 degrees. <input type="checkbox"/>     : Moves the screen in the direction of the arrows. <input type="checkbox"/>   : Moves to the previous or the next page. <p>To hide the operation icons, tap anywhere on the preview screen except for the icons. Tap again to display the icons.</p>
 (Preview menu)	<ul style="list-style-type: none"> <input type="checkbox"/> Save to Memory Device <input type="checkbox"/> Forward(Email) <input type="checkbox"/> Forward(Network Folder) <input type="checkbox"/> Print <p>When the message Delete When Complete is displayed, select On to delete faxes after completing processes such as Save to Memory Device or Forward(Email).</p>

(Box Menu)

Store Fax Data	Displays the screen for the Fax > Fax Settings tab. Tapping  on the screen starts scanning documents to store to the Stored Documents Box.
Print All	This item is displayed only when there are stored documents in the box. Prints all documents in the box. Selecting On in Delete When Complete deletes all documents when printing is complete.
Save All to Memory Device	This item is displayed only when there are stored documents in the box. Saves all documents in the box to external memory devices. Selecting On in Delete When Complete deletes all documents when printing is complete.
Delete All	This item is displayed only when there are stored documents in the box. Deletes all documents in the box.
Settings	Box Open Password: You can set a password or change it.

Related Information

➔ [“Sending the Same Documents Multiple Times” on page 199](#)

Faxing

- ➔ “Polling Send” on page 212
- ➔ “More” on page 208
- ➔ “Checking the Fax Job History” on page 216

Polling Send/Board

You can find **Polling Send/Board** in **Fax Box** on the home screen.

There is a Polling Send Box and 10 bulletin boards. You can store up to 100 pages of a single document in monochrome, and one document in each box.

Related Information

- ➔ “Sending Faxes On Demand (Using Polling Send/Bulletin Board Box)” on page 194

Polling Send

You can find **Polling Send** in **Fax Box > Polling Send/Board**.

Polling Send Box

Displays the setting items and values in **Settings** in  (Menu).

Add Document

Displays the screen for the **Fax > Fax Settings** tab. Tapping  on the screen starts scanning documents to store them in the box.

When a document is in the box, **Check Document** is displayed instead.

Check Document

Displays the preview screen when a document is in the box. You can print or delete the document while you are previewing.

preview screen	See the explanation for Fax Box > Stored Documents .
 (Preview menu)	<input type="checkbox"/> Save to Memory Device <input type="checkbox"/> Forward(Email) <input type="checkbox"/> Forward(Network Folder) <input type="checkbox"/> Send Fax When the message Delete When Complete is displayed, select On to delete faxes after completing processes such as Save to Memory Device or Forward(Email) .

(Menu)

Delete Document	This item is displayed only when there is a stored document in the box. Deletes the document stored in the box.
-----------------	---

Faxing

Settings	<input type="checkbox"/> Box Open Password: You can set a password or change it. <input type="checkbox"/> Delete Document After Sending: Setting this to On deletes the document in the box when the next request from a recipient to send the document (Polling Send) is completed. <input type="checkbox"/> Notify Send Result: When Email Notifications is set to On , the printer sends a notification to the destination specified in Recipient when a request to send the document (Polling Send) is completed.
----------	--

Related Information

- ➔ [“Stored Documents” on page 211](#)
- ➔ [“More” on page 208](#)
- ➔ [“Checking the Fax Job History” on page 216](#)

Unregistered Bulletin Board

You can find **Unregistered Bulletin Board** in **Fax Box > Polling Send/Board**. Select one of the **Unregistered Bulletin Board** boxes. After registering a board, the registered name is displayed on the box instead of **Unregistered Bulletin Board**.

You can register up to 10 bulletin boards.

Bulletin Board Box Settings

Name (Required)	Enter a name for the bulletin board box.
Subaddress(SEP)	Make or change the conditions for a recipient to receive the fax.
Password(PWD)	
Box Open Password	Set or change the password used to open the box.
Delete Document After Sending	Setting this to On deletes the document in the box when the next request from a recipient to send the document (Polling Send) is completed.
Notify Send Result	When Email Notifications is set to On , the printer sends a notification to the Recipient when a request to send the document (Polling Send) is completed.

Related Information

- ➔ [“Each Registered Bulletin Board” on page 213](#)

Each Registered Bulletin Board

You can find bulletin boards in **Fax Box > Polling Send/Board**. Select the box for which the registered name is displayed. The name displayed on the box is the name registered in **Unregistered Bulletin Board**.

You can register up to 10 bulletin boards.

(Registered Bulletin Board Name)

Displays the setting values of the items in **Settings** in  (Menu).

Faxing



Add Document

Displays the screen for the **Fax > Fax Settings** tab. Tapping  on the screen starts scanning documents to store to the box.

When a document is in the box, **Check Document** is displayed instead.

Check Document

Displays the preview screen when a document is in the box. You can print or delete the document while you are previewing.

preview screen	See the explanation for Fax Box > Stored Documents .
 (Preview menu)	See the explanation for Polling Send > Check Document >  (Preview menu) .

(Menu)

Delete Document	This item is displayed only when there is a stored document in the box. Deletes the document stored in the box.
Settings	Menus such as Name (Required) and Subaddress(SEP) are displayed. See the explanation for Unregistered Bulletin Board > Bulletin Board Box Settings
Delete Box	Deletes the stored document and changes the box status to unregistered.

Related Information

- ➔ [“Stored Documents” on page 211](#)
- ➔ [“Polling Send” on page 212](#)
- ➔ [“Unregistered Bulletin Board” on page 213](#)
- ➔ [“More” on page 208](#)
- ➔ [“Checking the Fax Job History” on page 216](#)

Checking the Status or Logs for Fax Jobs

Displaying Information when Received Faxes are Unprocessed (Unread/Not Printed/Not Saved/Not Forwarded)

When there are unprocessed received documents, the number of unprocessed jobs is displayed on the  on the home screen. See the table below for a definition of the "unprocessed".

Faxing

! Important:

When the inbox is full, receiving faxes is disabled. You should delete the documents from the inbox once they have been checked.

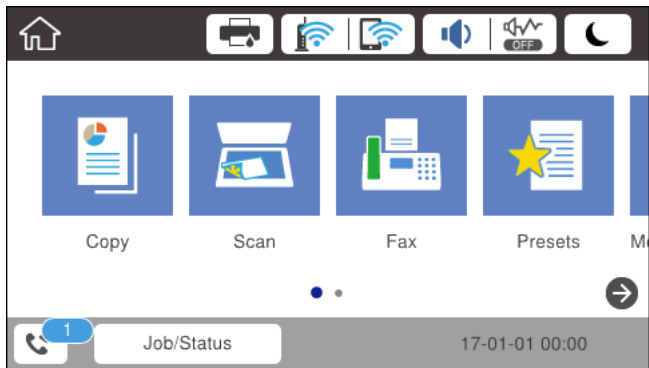

Received Fax Save/Forward Setting	Unprocessed Status
Printing*1	There are received documents waiting to be printed or printing is in progress.
Saving in the inbox or the confidential box	There are unread received documents in the inbox or the confidential box.
Saving in an external memory device	There are received documents that have not been saved in the device because there is no device containing a folder specifically created to save received documents connected to the printer or for other reasons.
Saving on a computer	There are received documents that have not been saved on the computer because the computer is in sleep mode or for other reasons.
Forwarding	There are received documents that have not been forwarded or failed to be forwarded*2.

*1 : When you have not set any of the fax save/forward settings, or when you have set to print received documents while saving them to an external memory device or a computer.

*2 : When you have set to save documents that could not be forwarded in the inbox, there are unread documents that failed to be forwarded in the inbox. When you have set to print documents that failed to be forwarded, printing is not complete.

Note:

If you are using more than one of the fax save/forward settings, the number of unprocessed jobs may be displayed as "2" or "3" even if only one fax has been received. For example, if you have set to save faxes in the inbox and on a computer and one fax is received, the number of unprocessed jobs is displayed as "2" if the fax has not been saved to the inbox and on a computer.

Related Information

- ➔ [“Viewing Received Faxes Saved in the Printer on the LCD Screen” on page 205](#)
- ➔ [“Checking Fax Jobs in Progress” on page 216](#)

Faxing

Checking Fax Jobs in Progress

You can display the screen to check fax jobs for which processing is incomplete. The following jobs are displayed on the check screen. From this screen, you can also print documents that have not yet been printed, or you can resend documents that have failed to send.

- Received fax jobs below
 - Not printed yet (When the jobs are set to be printed)
 - Not saved yet (When the jobs are set to be saved)
 - Not forwarded yet (When the jobs are set to be forwarded)
- Outgoing fax jobs that have failed to be sent (If you have enabled **Save Failure Data**)

Follow the steps below to display the check screen.

1. Tap **Job/Status** on the home screen.
2. Tap the **Job Status** tab, and then tap **Active**.
3. Select the job you want to check.

Related Information

➔ [“Displaying Information when Received Faxes are Unprocessed \(Unread/Not Printed/Not Saved/Not Forwarded\)” on page 214](#)

Checking the Fax Job History

You can check the history of sent or received fax jobs, such as the date, time and result for each job.

1. Tap **Job/Status** on the home screen.
2. Select **Log** on the **Job Status** tab.
3. Tap ▼ on the right, and then select **Send** or **Receive**.

The log for sent or received fax jobs is displayed in reverse chronological order. Tap a job you want to check to display the details.

You can also check the fax history by printing **Fax Log** by selecting **Fax** >  (More) > **Fax Report** > **Fax Log**.

Related Information

➔ [“More” on page 208](#)

Reprinting Received Documents

You can reprint received documents from the logs of printed fax jobs.

Note that the printed received documents are deleted in chronological order when the printer runs out of memory.

1. Tap **Job/Status** on the home screen.

Faxing

2. Select **Log** on the **Job Status** tab.
3. Tap ▼ on the right, and then select **Print**.
The history of sent or received fax jobs is displayed in reverse chronological order.
4. Select a job with  from the history list.
Check the date, time, and result to determine if it is the document you want print.
5. Tap **Print Again** to print the document.

Sending a Fax from a Computer

You can send faxes from the computer by using the FAX Utility and PC-FAX driver.

Note:

To install the FAX Utility, use the EPSON Software Updater. See Related Information below for details. For Windows users, you can install using the software disc supplied with the printer.

Related Information

- ➔ [“Enabling Sending Faxes from a Computer” on page 87](#)
- ➔ [“Software Update Tools \(EPSON Software Updater\)” on page 242](#)
- ➔ [“Installing the Latest Applications” on page 243](#)

Sending Documents Created Using an Application (Windows)

By selecting a printer fax from the **Print** menu of an application like Microsoft Word or Excel, you can directly transmit data such as documents, drawings, and tables you have created, with a cover sheet.

Note:

The following explanation uses Microsoft Word as an example. The actual operation may differ depending on the application you use. For details, see the application's help.

1. Using an application, create a document to transmit by fax.
2. Click **Print** from the **File** menu.
The application's **Print** window appears.
3. Select **XXXXXX (FAX)** (where XXXXXX is your printer name) in **Printer**, and then check the settings for fax sending.
 - Specify **1** in **Number of copies**. Fax may not be transmitted correctly if you specify **2** or more.
 - You cannot use functions such as **Print to File** that change the output port.
 - You may transmit up to 100 pages including cover sheet in one fax transmission.
4. Click **Printer Properties** or **Properties** if you want to specify **Paper Size**, **Orientation**, **Color**, **Image Quality**, or **Character Density**.

For details, see the PC-FAX driver help.

Faxing

5. Click **Print**.

Note:

When Using FAX Utility for the first time, a window for registering your information is displayed. Enter the necessary information, and then click **OK**. FAX Utility uses **Nickname** to manage fax jobs internally. Other information is automatically added to the cover sheet.

Recipient Settings screen of FAX Utility is displayed.

6. Specify a recipient and click **Next**.

- Selecting a recipient (name, fax number and so on) from **PC-FAX Phone Book**:

If the recipient is saved in the phone book, do the steps below.

- ➊ Click the **PC-FAX Phone Book** tab.
- ➋ Select the recipient from the list and click **Add**.

- Selecting a recipient (name, fax number and so on) from the contacts on the printer:

If the recipient is saved in the contacts on the printer, do the steps below.

- ➊ Click the **Contacts on Printer** tab.

Note that because the printer has a security function that allows administrators to restrict users from changing the printer's fax settings, you may need to enter an administrator password to continue.

- ➋ Select contacts from the list and click **Add** to proceed to **Add to Recipient** window.
- ➌ Select the contacts from the list displayed, and then click **Edit**.
- ➍ Add the personal data such as **Company/Corp.** and **Title** as necessary, and then click **OK** to return to the **Add to Recipient** window.
- ➎ As necessary, select the checkbox of **Register in the PC-FAX Phone Book** to save the contacts to **PC-FAX Phone Book**.
- ➏ Click **OK**.

- Specifying a recipient (name, fax number and so on) directly:

Do the steps below.

- ➊ Click the **Manual Dial** tab.
- ➋ Enter the necessary information.
- ➌ Click **Add**.

Furthermore, by clicking **Save to Phone Book**, you can save the recipient in the list under the **PC-FAX Phone Book** tab.

Note:

- If your printer's **Line Type** is set to **PBX** and the access code has been set to use # (hash) instead of entering the exact prefix code, enter # (hash). For details, see **Line Type** in **Basic Settings** from related information link below.
- If you have selected **Enter fax number twice** in the **Option settings** on the FAX Utility main screen, you need to enter the same number again when you click **Add** or **Next**.

The recipient is added to the **Recipient List** displayed in the upper part of the window.

7. Specify the content of the cover sheet.

- ➊ To attach a cover sheet, select one of the samples from **Cover Sheet**. Enter the **Subject** and **Message**. Note that there is no function to create an original cover sheet or to add an original cover sheet to the list.

If you do not want to attach a cover sheet, select **No cover sheet** from **Cover Sheet**.

Faxing

- ② Click **Cover Sheet Formatting** if you want to change the order of the items on the cover sheet. You can select the cover sheet size in **Paper Size**. You can also select a cover sheet at a different size to the document being transmitted.
- ③ Click **Font** if you want to change the font or font size used for the text on the cover sheet.
- ④ Click **Sender Settings** if you want to change the sender information.
- ⑤ Click **Detailed Preview** if you want to check the cover sheet with the subject and the message you entered.
- ⑥ Click **Next**.

8. Check the transmission content and click **Send**.

Make sure the name and fax number of the recipient are correct before transmitting. Click **Preview** to preview the cover sheet and document to transmit.

Once transmission starts, a window displaying the transmission status appears.

Note:

- To stop transmitting, select the data, and click **Cancel** . You can also cancel using the printer's control panel.
- If an error occurs during transmission, the **Communication error** window appears. Check the error information and retransmit.
- The Fax Status Monitor screen (the screen mentioned above where you can check the transmission status) is not displayed if **Display Fax Status Monitor During Transmission** is not selected in the **Optional Settings** screen of the FAX Utility main screen.

Sending Documents Created Using an Application (Mac OS)

By selecting a fax-capable printer from the **Print** menu of a commercially available application, you can send data such as documents, drawings, and tables, you have created.

Note:

The following explanation uses *Text Edit*, a standard Mac OS application as an example.

1. Create the document you want to send by fax in an application.
2. Click **Print** from the **File** menu.
The application's **Print** window is displayed.
3. Select your printer (fax name) in **Name**, click ▼ to display the detailed settings, check the print settings, and then click **OK**.

4. Make settings for each item.

- Specify **1** in **Number of copies**. Even if you specify **2** or more, only 1 copy is sent.
- You can send up to 100 pages in one fax transmission.

Note:

The page size of documents you can send is the same as the paper size you can fax from the printer.

5. Select Fax Settings from the popup menu, and then make settings for each item.

See the PC-FAX driver's help for explanations on each setting item.

Click  at the bottom left of the window to open the PC-FAX driver's help.

Faxing

6. Select the Recipient Settings menu, and then specify the recipient.

- Specifying a recipient (name, fax number, and so on) directly:

Click the **Add** item, enter the necessary information, and then click . The recipient is added to the Recipient List displayed in the upper part of the window.

If you have selected "Enter fax number twice" in the PC-FAX driver settings, you need to enter the same number again when you click .

If your fax connection line requires a prefix code, enter External Access Prefix.

Note:

If your printer's Line Type is set to **PBX** and the access code has been set to use # (hash) instead of entering the exact prefix code, enter # (hash). For details, see *Line Type in Basic Settings from Related Information* link below.

- Selecting a recipient (name, fax number, and so on) from the phone book:

If the recipient is saved in the phone book, click . Select the recipient from the list, and then click **Add > OK**.

If your fax connection line requires a prefix code, enter External Access Prefix.

Note:

If your printer's Line Type is set to **PBX** and the access code has been set to use # (hash) instead of entering the exact prefix code, enter # (hash). For details, see *Line Type in Basic Settings from Related Information* link below.

7. Check the recipient settings, and then click **Fax**.

Sending starts.

Make sure the name and fax number of the recipient are correct before transmitting.

Note:

- If you click the printer icon in Dock, the transmission status check screen is displayed. To stop sending, click the data, and then click **Delete**.
- If an error occurs during transmission, the **Sending failed** message is displayed. Check the transmission records on the **Fax Transmission Record** screen.
- Mixed paper size documents may not be sent correctly.

Receiving Faxes on a Computer

You can receive faxes and save them as PDF files to the computer connected to the printer. The FAX Utility comes with features including how to specify a folder to save the faxes. Install the FAX Utility before using this feature.

Note:

You can use one of the following methods to install the FAX Utility.

- Using the EPSON Software Updater (application for updating software)
- Using the disc supplied with your printer. (Windows users Only)

Faxing

Important:

- ❑ To receive faxes on a computer, the **Receive Mode** on the printer's control panel must be set to **Auto**. If your organization has a printer administrator, contact your administrator for information on the printer setting status. See "Related Information" below to make settings.
- ❑ The computer set to receive faxes should always be on. Received documents are saved in the printer's memory temporarily before the documents are saved on the computer. If you turn off the computer, the printer's memory might become full as it cannot send the documents to the computer.
- ❑ The number of documents that have been temporarily saved to the printer's memory are displayed on the  on the home screen.
- ❑ To read the received faxes, you need to install a PDF viewer such as Adobe Reader in the computer.

Related Information

- ➔ ["Setting Receive Mode" on page 76](#)
- ➔ ["Software Update Tools \(EPSON Software Updater\)" on page 242](#)
- ➔ ["Installing the Latest Applications" on page 243](#)

Saving Incoming Faxes on a Computer

You can make settings to save incoming faxes on a computer by using the FAX Utility. Install the FAX Utility on the computer in advance.

For details, see Basic Operations in the FAX Utility help (displayed on the main window). If the password entry screen is displayed on the computer screen while you are making settings, enter the password. If your organization has a printer administrator and you do not know the password, contact the administrator.

Note:

You can receive faxes on a computer and print from the printer at the same time. If your organization has a printer administrator, contact your administrator for information on the printer setting status. See "Related Information" below to make settings.

Related Information

- ➔ ["Making Save to Computer Setting to Also Print on the Printer to Receive Faxes" on page 87](#)
- ➔ ["Application for Configuring Fax Operations and Sending Faxes \(FAX Utility\)" on page 240](#)

Canceling the Feature that Saves Incoming Faxes to the Computer

You can cancel saving faxes to the computer by using the FAX Utility.

For details, see Basic Operations in the FAX Utility help (displayed on the main window).

Note:

- ❑ *If there are any faxes that have not been saved to the computer, you cannot cancel the feature that saves faxes on the computer.*
- ❑ *You can also change the settings on the printer. If your organization has a printer administrator, contact your administrator for information on canceling settings for saving received faxes on the computer. See "Related Information" below to change settings.*

Faxing

Related Information

- ➔ [“Making Save to Computer Setting not to Receive Faxes” on page 88](#)
- ➔ [“Application for Configuring Fax Operations and Sending Faxes \(FAX Utility\)” on page 240](#)

Checking for New Faxes (Windows)

By setting up a computer to save faxes received by the printer, you can check the processing status of received faxes, and whether or not there are any new faxes using the fax icon on the Windows task bar. By setting up the computer to display a notification when new faxes are received, a notification screen pops up near the Windows system tray, and you can check the new faxes.



Note:

- Received fax data saved to the computer is removed from the printer's memory.
- You need Adobe Reader to view the received faxes because they are saved as PDF files.

Using the Fax Icon on the Task Bar (Windows)

You can check for new faxes and the operation status by using the fax icon displayed on the Windows taskbar.

1. Check the icon.

-  : Standing by.
-  : Checking for new faxes.
-  : Importing new faxes is complete.

2. Right-click the icon, and then click **Open the received fax folder**.

The received fax folder is displayed. Check the date and the sender in the file name, and then open the PDF file.

While the fax icon indicates that it is standing by, you can check for new faxes instantly by selecting **Check new faxes now**.

Note:

Received faxes are automatically renamed using the following naming format.

YYYYMMDDHHMMSS_XXXXXXXXXX_nnnnn (Year/Month/Day/Hour/Minute/Second_sender's number)

Using the Notification Window (Windows)

When you set to notify you the new faxes exist, a notification window is displayed near the task bar for each the fax.

1. Check the notification screen displayed on your computer screen.

Note:

The notification screen disappears if no operation is performed for a given length of time. You can change the notification settings such as the display time.

Faxing

- Click anywhere in the notification screen, except for the  button.

The folder you specified to save new faxes opens. Check the date and the sender in the file name, and then open the PDF file.

Note:

Received faxes are automatically renamed using the following naming format.

YYYYMMDDHHMMSS_XXXXXXXXXX_NNNNN (Year/Month/Day/Hour/Minute/Second_sender's number)

Checking for New Faxes (Mac OS)

You can check for new faxes using one of the following methods. This is available only on computers set to "Save" (**save faxes on this computer**).

- Open the received fax folder (specified in **Received Fax Output Settings**.)
- Open the Fax Receive Monitor and click **Check new faxes now**.
- Notification that new faxes have been received

Select the **Notify me of new faxes via a dock icon** in the **Fax Receive Monitor > Preferences** in the FAX Utility, the fax receive monitor icon on the Dock jumps to notify you that new faxes have arrived.

Open the Received Fax Folder from Received Fax Monitor (Mac OS)

You can open the save folder from the computer specified to receive faxes when selecting "Save" (**save faxes on this computer**).

- Click the received fax monitor icon on the Dock to open **Fax Receive Monitor**.
- Select the printer and click **Open folder**, or double click the printer name.
- Check the date and the sender in the file name, and then open the PDF file.

Note:

Received faxes are automatically renamed using the following naming format.

YYYYMMDDHHMMSS_XXXXXXXXXX_NNNNN (Year/Month/Day/Hour/Minute/Second_sender's number)

Information sent from the sender is displayed as the sender's number. This number may not be displayed depending on the sender.

Replacing Ink Supply Units and Other Consumables

Checking the Status of the Remaining Ink and the Maintenance Box

You can check the approximate ink levels and the approximate service life of the maintenance box from the control panel or the computer.

Note:

You can continue printing while the ink low message is displayed. Replace the ink supply units when required.

Checking the Status of the Remaining Ink and the Maintenance Box - Control Panel

1. Press the  button on the control panel.
2. Select **Printer Status**.

Note:

The indicator on the far right indicates the available space in the maintenance box.

Checking the Status of the Remaining Ink and the Maintenance Box - Windows

1. Access the printer driver window.
2. Click **EPSON Status Monitor 3** on the **Maintenance** tab, and then click **Details**.

Note:

*If EPSON Status Monitor 3 is disabled, click **Extended Settings** on the **Maintenance** tab, and then select **Enable EPSON Status Monitor 3**.*

Checking the Status of the Remaining Ink and the Maintenance Box - Mac OS

1. Select **System Preferences** from the  menu > **Printers & Scanners** (or **Print & Scan**, **Print & Fax**), and then select the printer.
2. Click **Options & Supplies** > **Utility** > **Open Printer Utility**.
3. Click **EPSON Status Monitor**.

Ink Supply Unit Codes

The following are the codes for genuine Epson ink supply units.

Note:

- Ink supply unit codes may vary by location. For the correct codes in your area, contact Epson support.
- Although the ink supply units may contain recycled materials, this does not affect printer function or performance.
- Specifications and appearance of the ink supply unit are subject to change without prior notice for improvement.

Black	Cyan	Magenta	Yellow
T01D1 T01C1	T01D2 T01C2	T01D3 T01C3	T01D4 T01C4

Visit the following website for information on Epson's ink supply unit yields.

<http://www.epson.eu/pageyield>

Epson recommends the use of genuine Epson ink supply units. Epson cannot guarantee the quality or reliability of non-genuine ink. The use of non-genuine ink may cause damage that is not covered by Epson's warranties, and under certain circumstances, may cause erratic printer behavior. Information about non-genuine ink levels may not be displayed.

Ink Supply Unit Handling Precautions

Storing precautions for ink

- Keep the ink supply units out of direct sunlight.
- Do not store the ink supply units in high or freezing temperatures.
- Epson recommends using the ink supply unit before the date printed on the package.
- For best results, store ink supply unit packages with their bottom down.
- After bringing an ink supply unit inside from a cold storage site, allow it to warm up at room temperature for at least 12 hours before using it.
- Do not drop or knock the ink supply unit against hard objects; otherwise, the ink may leak.

Handling precautions for replacing ink

- Do not touch the sections shown in the illustration. Doing so may prevent normal operation and printing.

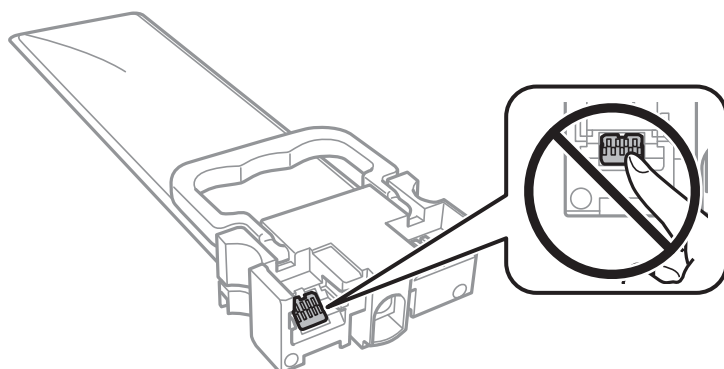

Replacing Ink Supply Units and Other Consumables

- ❑ Install all ink supply units; otherwise you cannot print.
- ❑ Do not turn off the printer during ink charging. If the ink charging is incomplete, you may not be able to print.
- ❑ Do not leave the printer with the ink supply units removed; otherwise, ink remaining in the print head nozzles may dry out and you may not be able to print.
- ❑ If you need to remove an ink supply unit temporarily, make sure you protect the ink supply area from dirt and dust. Store the ink supply unit in the same environment as the printer. Because the ink supply port is equipped with a valve designed to contain the release of excess ink, there is no need to supply your own covers or plugs.
- ❑ Removed ink supply units may have ink around the ink supply port, so be careful not to get any ink on the surrounding area when removing the ink supply units.
- ❑ This printer uses ink supply units equipped with a green chip that monitors information such as the amount of remaining ink for each ink supply unit. This means that even if the ink supply unit is removed from the printer before it is expended, you can still use the ink supply unit after reinserting it back into the printer.
- ❑ To ensure you receive premium print quality and to help protect your print head, a variable ink safety reserve remains in the ink supply unit when your printer indicates to replace the ink supply unit. The yields quoted for you do not include this reserve.
- ❑ Do not disassemble or remodel the ink supply unit, otherwise you may not be able to print normally.
- ❑ You cannot use the ink supply units that came with the printer for the replacement.
- ❑ Do not leave the printer with the ink supply units removed; otherwise, ink remaining in the print head nozzles may dry out and you may not be able to print.

Consumption of ink

- ❑ To maintain optimum print head performance, some ink is consumed from all ink supply units during maintenance operations such as print head cleaning. Ink may also be consumed when you turn on the printer.
- ❑ When printing in monochrome or grayscale, color inks instead of black ink may be used depending on the paper type or print quality settings. This is because a mixture of color inks is used to create black.
- ❑ The ink in the ink supply units supplied with your printer is partly used during initial setup. In order to produce high quality printouts, the print head in your printer will be fully charged with ink. This one-off process consumes a quantity of ink and therefore these ink supply units may print fewer pages compared to subsequent ink supply units.
- ❑ Quoted yields may vary depending on the images that you are printing, the paper type that you are using, the frequency of your prints and environmental conditions such as temperature.
- ❑ For best results, use up ink supply unit within two years of installation.

Replacing Ink Supply Units

When a message is displayed prompting you to replace the ink supply units, select **How To** and then view the animations displayed on the control panel to learn how to replace the ink supply units.

Related Information

- ➔ [“Ink Supply Unit Handling Precautions” on page 225](#)

Maintenance Box Code

Epson recommends the use of a genuine Epson maintenance box.

Maintenance box code: T6716

**Important:**

Once a maintenance box has been installed in a printer it cannot be used with other printers.

Maintenance Box Handling Precautions

Read the following instructions and *Important Safety Instructions* (paper manual) before replacing the maintenance box.

- Do not touch the green chip on the side of the maintenance box. Doing so may prevent normal operation and printing.
- Do not tilt the used maintenance box until after it is sealed in the plastic bag; otherwise ink may leak.
- Do not store the maintenance box in high or freezing temperatures.
- Keep the maintenance box out of direct sunlight.
- Do not replace the maintenance box during printing; otherwise, ink may leak.
- Do not reuse a maintenance box which has been removed and left detached for a long period. Ink inside the box will have solidified and no more ink can be absorbed.
- Do not remove the maintenance box and its cover except when replacing the maintenance box; otherwise ink may leak.

Replacing a Maintenance Box

In some print cycles a very small amount of surplus ink may be collected in the maintenance box. To prevent ink leakage from the maintenance box, the printer is designed to stop printing when the absorbing capacity of the maintenance box has reached its limit. Whether and how often this is required will vary according to the number of pages you print, the type of material that you print and the number of cleaning cycles that the printer performs.

When a message is displayed prompting you to replace the maintenance box, refer to the animations displayed on the control panel. The need for replacement of the box does not mean that your printer has ceased to operate in accordance with its specifications. The Epson warranty does not cover the cost of this replacement. It is a user-serviceable part.

Note:

When it is full, you cannot print until the maintenance box is replaced to avoid ink leakage. However, non-printing features are available.

Related Information

➔ [“Maintenance Box Handling Precautions” on page 227](#)

Temporarily Printing with Black Ink

When color ink is expended and black ink still remains, you can use the following settings to continue printing for a short time using only black ink.

- Type of paper: plain papers, Envelope
- Color: **Grayscale**
- EPSON Status Monitor 3: Enabled (for Windows only)

Because this feature is only available for approximately five days, replace the expended ink supply unit as soon as possible.

Note:

- If EPSON Status Monitor 3 is disabled, access the printer driver, click **Extended Settings** on the **Maintenance** tab, and then select **Enable EPSON Status Monitor 3**.*
- The available period varies depending on the usage conditions.*

Temporarily Printing with Black Ink - Control Panel

1. When a message is displayed prompting you to replace the ink supply units, tap **Proceed**.
A message is displayed telling you that you can temporarily print with black ink.
2. Check the message, and then tap **Proceed**.
3. If you want to print in monochrome, select **No, remind me later**.
The ongoing job is canceled.
4. Now you can copy originals or print received faxes on plain paper in monochrome. Select the feature you want to use on the home screen.

Replacing Ink Supply Units and Other Consumables

Temporarily Printing with Black Ink - Windows

1. When the following window is displayed, cancel printing.

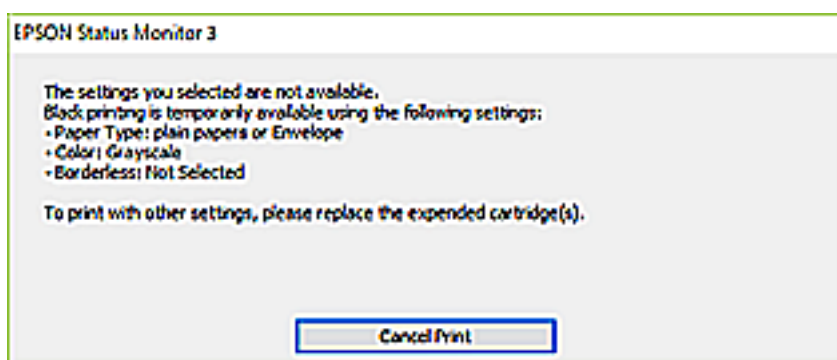
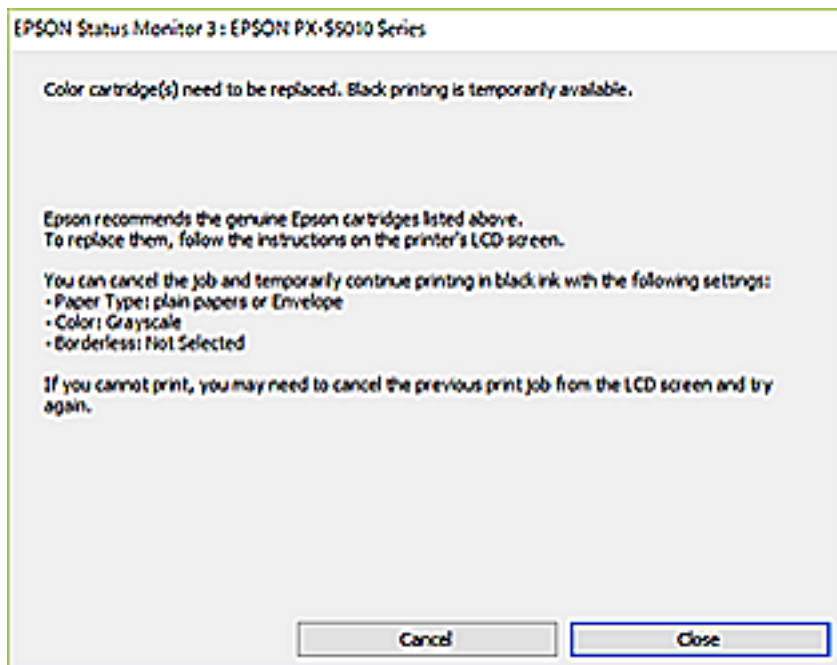
**Note:**

If you cannot cancel printing from the computer, cancel using the printer's control panel.

2. Access the printer driver window.
3. Select **plain papers** or **Envelope** as the **Paper Type** setting on the **Main** tab.
4. Select **Grayscale**.
5. Set the other items on the **Main** and **More Options** tabs as necessary, and then click **OK**.
6. Click **Print**.
7. Click **Print in Black** in the window displayed.

Conserving Black Ink when the Black Ink Is Low (for Windows Only)

When black ink is running low and there is enough color ink remaining, you can use a mixture of color inks to create black. You can continue printing while preparing a replacement black ink supply unit.

This feature is only available when you select the following settings in the printer driver.

- Paper Type: **plain papers**
- Quality: **Standard**
- EPSON Status Monitor 3: Enabled

Note:

- If **EPSON Status Monitor 3** is disabled, access the printer driver, click **Extended Settings** on the **Maintenance** tab, and then select **Enable EPSON Status Monitor 3**.
- Composite black looks slightly different from pure black. In addition, the print speed is reduced.
- To maintain the quality of the print head, black ink is also consumed.

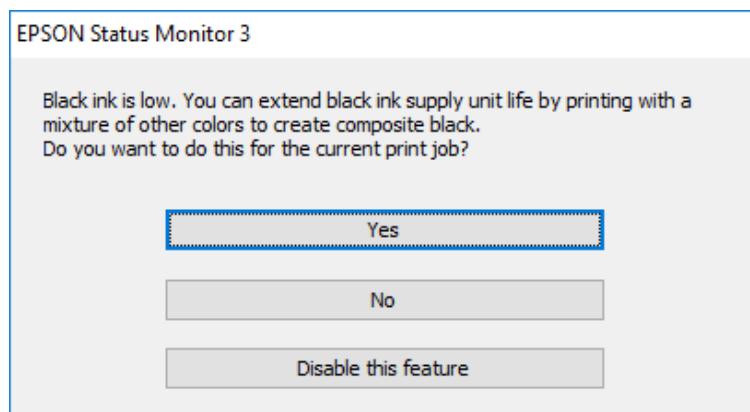

Options	Description
Yes	Select to use a mixture of color inks to create black. This window is displayed the next time you print a similar job.
No	Select to continue using the remaining black ink. This window is displayed the next time you print a similar job.
Disable this feature	Select to continue using the remaining black ink. This window is not displayed until you replace the black ink supply unit and it runs low again.

Maintaining the Printer

Checking and Cleaning the Print Head

If the nozzles are clogged, the printouts become faint, there is visible banding, or unexpected colors appear. When print quality has declined, use the nozzle check feature and check if the nozzles are clogged. If the nozzles are clogged, clean the print head. You can perform a nozzle check and head cleaning from the control panel or the computer.



Important:

Do not open the front cover or turn off the printer during head cleaning. If the head cleaning is incomplete, you may not be able to print.

Note:

- Because print head cleaning uses some ink, clean the print head only if quality declines.
- When ink is low, you may not be able to clean the print head.
- If print quality has not improved after repeating nozzle check and head cleaning about four times, wait for at least six hours without printing, and then run the nozzle check again and repeat the head cleaning if necessary. We recommend to turn off the printer. If print quality has still not improved, contact Epson support.
- To prevent the print head from drying out, do not unplug the printer while the power is on.

Checking and Cleaning the Print Head - Control Panel

1. Load A4-size plain paper in the printer.
2. Select **Settings** on the home screen.
3. Select **Maintenance > Print Head Nozzle Check**.
4. Follow the on-screen instructions to print the nozzle check pattern.
5. Examine the printed pattern. If there are broken lines or missing segments as shown in the "NG" pattern, the print head nozzles may be clogged. Go to the next step. If you cannot see any broken lines or missing segments as in the following "OK" pattern, the nozzles are not clogged. Select  to close the nozzle check feature.

OK

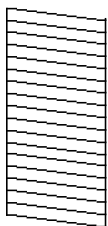

NG

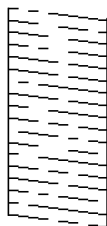

6. Select , and then follow the on-screen instructions to clean the print head.

Maintaining the Printer

7. When cleaning is finished, print the nozzle check pattern again. Repeat cleaning and printing the pattern until all lines are printed completely.

Related Information

- ➔ [“Loading Paper in the Paper Cassette” on page 32](#)

Checking and Cleaning the Print Head - Windows

1. Load A4-size plain paper in the printer.
2. Access the printer driver window.
3. Click **Nozzle Check** on the **Maintenance** tab.
4. Follow the on-screen instructions.

Related Information

- ➔ [“Loading Paper in the Paper Cassette” on page 32](#)
- ➔ [“Accessing the Printer Driver” on page 127](#)

Checking and Cleaning the Print Head - Mac OS

1. Load A4-size plain paper in the printer.
2. Select **System Preferences** from the  menu > **Printers & Scanners** (or **Print & Scan**, **Print & Fax**), and then select the printer.
3. Click **Options & Supplies** > **Utility** > **Open Printer Utility**.
4. Click **Nozzle Check**.
5. Follow the on-screen instructions.

Related Information

- ➔ [“Loading Paper in the Paper Cassette” on page 32](#)

Aligning Ruled Lines

If vertical lines look misaligned, align the ruled lines.

1. Load A4-size plain paper in the printer.
2. Select **Settings** on the home screen.
3. Select **Maintenance** > **Ruled Line Alignment**.

Maintaining the Printer

4. Follow the on-screen instructions to print an alignment pattern.
5. Follow the on-screen instructions to align the ruled lines. Find and enter the number for the pattern that has the least misaligned vertical line.

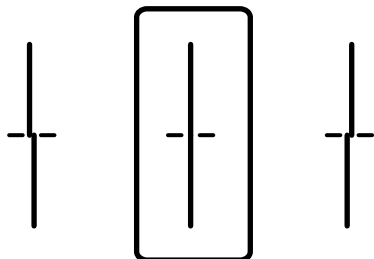

Related Information

- ➔ [“Loading Paper in the Paper Cassette” on page 32](#)

Cleaning the Paper Path for Ink Smears

When the printouts are smeared or scuffed, clean the roller inside.



Important:

Do not use tissue paper to clean the inside of the printer. The print head nozzles may be clogged with lint.

1. Load A4-size plain paper in the paper source that you want to clean.
2. Select **Settings** on the home screen.
3. Select **Maintenance > Paper Guide Cleaning**.
4. Select the paper source, and then follow the on-screen instructions to clean the paper path.

Note:

Repeat this procedure until the paper is not smeared with ink. If the printouts are still smeared, clean the other paper sources.

Related Information

- ➔ [“Loading Paper in the Paper Cassette” on page 32](#)

Cleaning the ADF

When the copied or scanned images from the ADF are smeared or the originals do not feed in the ADF correctly, clean the ADF.



Important:

Never use alcohol or thinner to clean the printer. These chemicals can damage the printer.

Maintaining the Printer

1. Open the ADF cover.

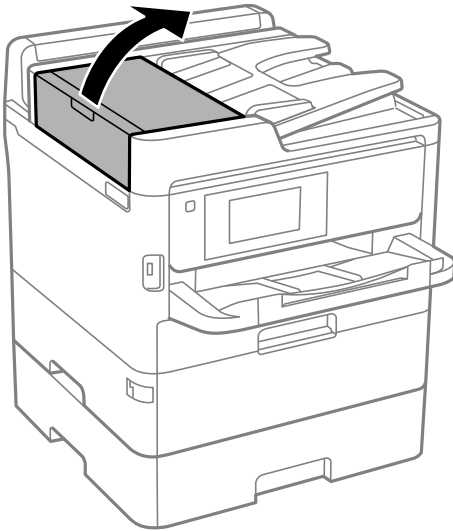

2. Use a soft, moist cloth to clean the roller and the interior of the ADF.

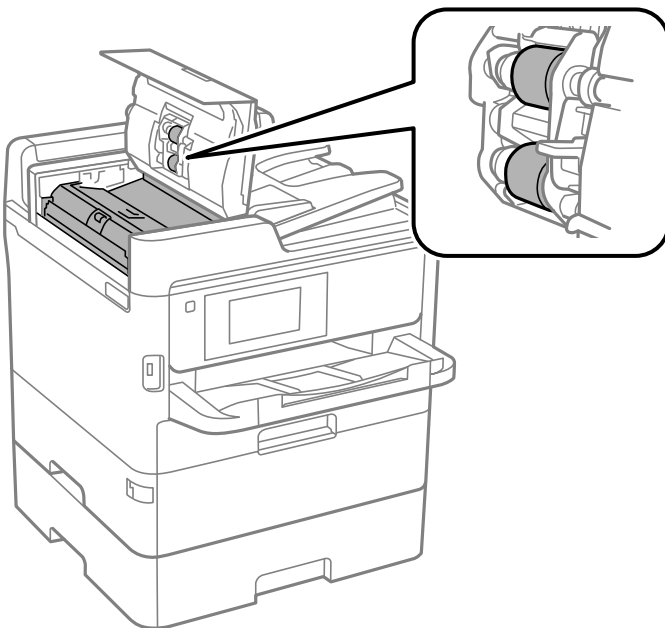

! **Important:**

- ❑ *Using a dry cloth may damage the surface of the roller.*
- ❑ *Use the ADF after the roller has dried.*

Maintaining the Printer

3. Open the document cover.

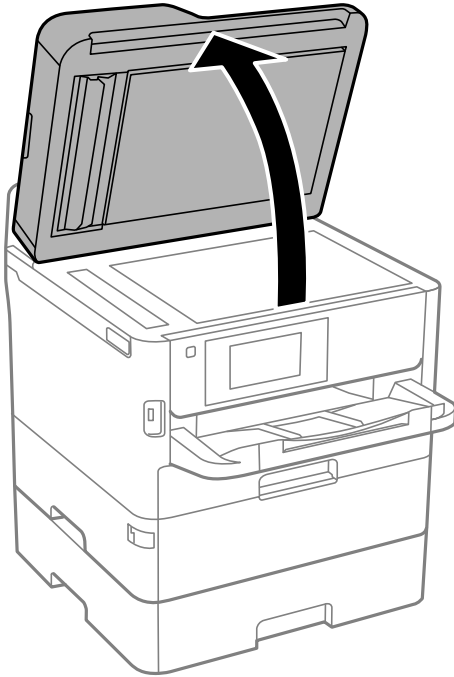

4. Clean the part that is shown in the illustration.

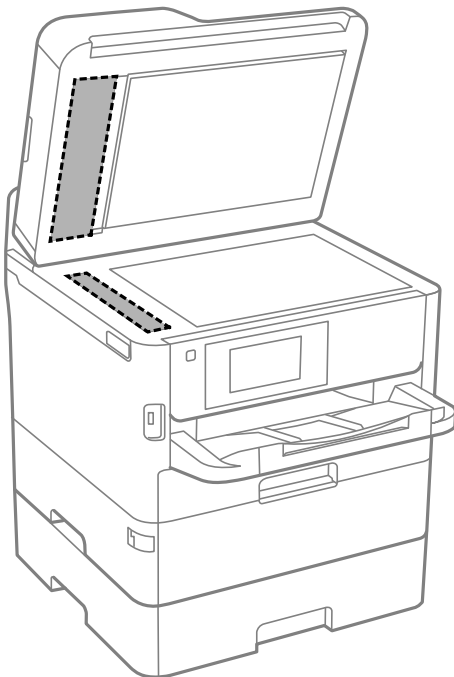

! **Important:**

- ❑ *If the glass surface is stained with grease or some other hard-to-remove material, use a small amount of glass cleaner and a soft cloth to remove it. Wipe off all remaining liquid.*
- ❑ *Do not press the glass surface too hard.*
- ❑ *Be careful not to scratch or damage the surface of the glass. A damaged glass surface can decrease the scan quality.*

Cleaning the Scanner Glass

When the copies or scanned images are smeared, clean the scanner glass.

**Caution:**

Be careful not to trap your hand or fingers when opening or closing the document cover. Otherwise you may be injured.

**Important:**

Never use alcohol or thinner to clean the printer. These chemicals can damage the printer.

1. Open the document cover.

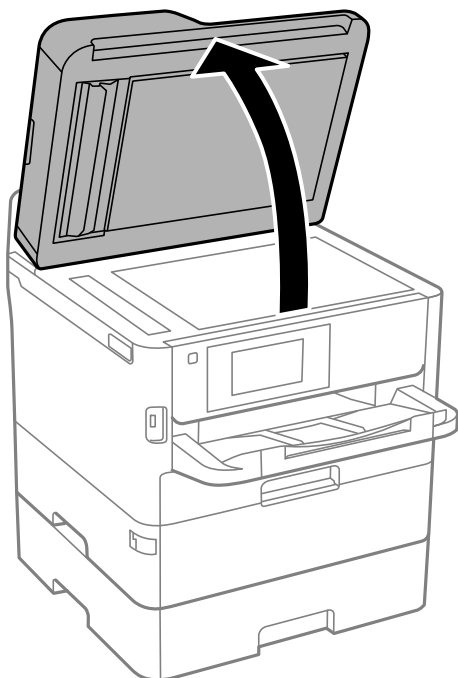

2. Use a soft, dry, clean cloth to clean the surface of the scanner glass.

**Important:**

- If the glass surface is stained with grease or some other hard-to-remove material, use a small amount of glass cleaner and a soft cloth to remove it. Wipe off all remaining liquid.*
- Do not press the glass surface too hard.*
- Be careful not to scratch or damage the surface of the glass. A damaged glass surface can decrease the scan quality.*

Network Service and Software Information

This section introduces the network services and software products available for your printer from the Epson website or the supplied software disc.

Application for Configuring Printer Operations (Web Config)

Web Config is an application that runs in a web browser, such as Internet Explorer and Safari, on a computer or smart device. You can confirm the printer status or change the network service and printer settings. To use the Web Config, connect the printer and the computer or device to the same network.

The following browsers are supported.

OS	Browser
Windows XP SP3 or later	Microsoft Edge, Internet Explorer 8 or later, Firefox*, Chrome*
Mac OS X v10.6.8 or later	Safari*, Firefox*, Chrome*
iOS*	Safari*
Android 2.3 or later	Default browser
Chrome OS*	Default browser

* Use the latest version.

Running Web Config on a Web Browser

1. Check the printer's IP address.

Tap the network icon on the printer's home screen, and then tap the active connection method to confirm the printer's IP address.

Note:

You can also check the IP address by printing the network connection report.

2. Launch a Web browser from a computer or smart device, and then enter the printer's IP address.

Format:

IPv4: `http://the printer's IP address/`

IPv6: `http://[the printer's IP address]/`

Examples:

IPv4: `http://192.168.100.201/`

IPv6: `http://[2001:db8::1000:1]/`

Network Service and Software Information

Note:

Using the smart device, you can also run Web Config from the maintenance screen of Epson iPrint.

Related Information

- ➔ [“Using Epson iPrint” on page 162](#)
- ➔ [“Network Settings” on page 61](#)

Running Web Config on Windows

When connecting a computer to the printer using WSD, follow the steps below to run Web Config.

1. Open the printer list on the computer.
 - Windows 10/Windows Server 2016
Click on the start button, and then select **Windows System > Control Panel > View devices and printers in Hardware and Sound**.
 - Windows 8.1/Windows 8/Windows Server 2012 R2/Windows Server 2012
Select **Desktop > Settings > Control Panel > View devices and printers in Hardware and Sound (or Hardware)**.
 - Windows 7/Windows Server 2008 R2
Click the start button, and select **Control Panel > View devices and printers in Hardware and Sound**.
 - Windows Vista/Windows Server 2008
Click the start button, and select **Control Panel > Printers in Hardware and Sound**.
2. Right-click on your printer and select **Properties**.
3. Select the **Web Service** tab and click the URL.

Running Web Config on Mac OS

1. Select **System Preferences** from the  menu > **Printers & Scanners** (or **Print & Scan, Print & Fax**), and then select the printer.
2. Click **Options & Supplies > Show Printer Webpage**.

Application for Scanning Documents and Images (Epson Scan 2)

Epson Scan 2 is an application for controlling scanning. You can adjust the size, resolution, brightness, contrast, and quality of the scanned image. You can also start Epson Scan 2 from a TWAIN-compliant scanning application. See the application's help for details.

Network Service and Software Information

Starting on Windows

Note:

For Windows Server operating systems, make sure the **Desktop Experience** feature is installed.

- ❑ Windows 10/Windows Server 2016

Click the start button, and then select **EPSON > Epson Scan 2**.

- ❑ Windows 8.1/Windows 8/Windows Server 2012 R2/Windows Server 2012

Enter the application name in the search charm, and then select the displayed icon.

- ❑ Windows 7/Windows Vista/Windows XP/Windows Server 2008 R2/Windows Server 2008/Windows Server 2003 R2/Windows Server 2003

Click the start button, and then select **All Programs** or **Programs > EPSON > Epson Scan 2 > Epson Scan 2**.

Starting on Mac OS

Note:

Epson Scan 2 does not support the Mac OS fast user switching feature. Turn off fast user switching.

Select **Go > Applications > Epson Software > Epson Scan 2**.

Related Information

- ➔ [“Scanning Using Epson Scan 2” on page 186](#)
- ➔ [“Installing the Latest Applications” on page 243](#)

Adding the Network Scanner

Before using Epson Scan 2, you need to add the network scanner.

1. Start the software, and then click **Add** on the **Scanner Settings** screen.

Note:

- ❑ If **Add** is grayed out, click **Enable Editing**.

- ❑ If the main screen of Epson Scan 2 is displayed, it has already been connected to the scanner. If you want to connect to another network, select **Scanner > Settings** to open the **Scanner Settings** screen.

2. Add the network scanner. Enter the following items, and then click **Add**.

- ❑ **Model:** Select the scanner you want to connect to.

- ❑ **Name:** Enter the scanner name within 32 characters.

- ❑ **Search for Network:** When the computer and the scanner are on the same network, the IP address is displayed. If it is not displayed, click the  button. If the IP address is still not displayed, click **Enter address**, and then enter the IP address directly.

3. Select the scanner on the **Scanner Settings** screen, and then click **OK**.

Application for Configuring Scanning from the Computer (Document Capture Pro)

Document Capture Pro* is an application that allows you to configure settings for scanned images sent from the printer to a computer over a network.

After checking the scanned image, you can configure various scan settings on the computer such as the file saving format, where to save the scanned image, and the forwarding destination. See the Document Capture Pro help for details on using the application.

*The names are for Windows. For Mac OS, the name is Document Capture. For Windows Server, the name is Document Capture Pro Server.

Starting on Windows

- Windows 10/Windows Server 2016

Click the start button, and then select **Epson Software > Document Capture Pro**.

- Windows 8.1/Windows 8/Windows Server 2012 R2/Windows Server 2012

Enter the application name in the search charm, and then select the displayed icon.

- Windows 7/Windows Vista/Windows XP/Windows Server 2008 R2/Windows Server 2008/Windows Server 2003 R2/Windows Server 2003

Click the start button, and select **All Programs** or **Programs > Epson Software > Document Capture Pro**.

Starting on Mac OS

Select **Go > Applications > Epson Software > Document Capture**.

Related Information

- ➔ [“Scanning Using the Settings Registered on the Computer \(Document Capture Pro\)” on page 177](#)
- ➔ [“Installing the Latest Applications” on page 243](#)

Application for Configuring Fax Operations and Sending Faxes (FAX Utility)

FAX Utility is an application that allows you to configure various settings for sending faxes from a computer. You can create or edit the contacts list to be used when sending a fax, configure to save received faxes in PDF format on the computer, and so on. See the application's help for details.

Note:

- Windows Server operating systems are not supported.*
- Before installing the FAX Utility, make sure you have installed the printer driver for this printer; this does not include the PostScript printer driver and Epson universal printer driver.*

Starting on Windows

- Windows 10

Click the start button, and select **Epson Software > FAX Utility**.

Network Service and Software Information

- ❑ Windows 8.1/Windows 8

Enter the application name in the search charm, and then select the displayed icon.

- ❑ Windows 7/Windows Vista/Windows XP

Click the start button, and select **All Programs** (or **Programs**) > **Epson Software** > **FAX Utility**.

Starting on Mac OS

Select **System Preferences** from the  menu > **Printers & Scanners** (or **Print & Scan, Print & Fax**), and then select the printer (FAX). Click **Options & Supplies** > **Utility** > **Open Printer Utility**.

Related Information

- ➔ [“Receiving Faxes on a Computer” on page 220](#)
- ➔ [“Installing the Latest Applications” on page 243](#)

Application for Sending Faxes (PC-FAX Driver)

PC-FAX driver is an application that allows you to send a document created on a separate application as a fax directly from the computer. PC-FAX driver is installed when you install FAX Utility. See the application's help for details.

Note:

- ❑ *Windows Server operating systems are not supported.*
- ❑ *The operation differs depending on the application you used to create the document. See the application's help for details.*

Accessing from Windows

In the application, select **Print** or **Print Setup** from the **File** menu. Select your printer (FAX), and then click **Preferences** or **Properties**.

Accessing from Mac OS

In the application, select **Print** from the **File** menu. Select your printer (FAX) as the **Printer** setting, and then select **Fax Settings** or **Recipient Settings** from the pop-up menu.

Related Information

- ➔ [“Sending a Fax from a Computer” on page 217](#)
- ➔ [“Application for Configuring Fax Operations and Sending Faxes \(FAX Utility\)” on page 240](#)

Application for Printing Web Pages (E-Web Print)(for Windows Only)

E-Web Print is an application that allows you to easily print web pages with various layouts. See the application's help for details. You can access the help from the **E-Web Print** menu on the **E-Web Print** tool bar.

Note:

- ❑ *Windows Server operating systems are not supported.*
- ❑ *Check for supported browsers and the latest version from the download site.*

Starting

When you install E-Web Print, it is displayed in your browser. Click **Print** or **Clip**.

Application for Configuring Multiple Devices (EpsonNet Config)

EpsonNet Config is an application that allows you to set the network interface addresses and protocols. See the operations guide for EpsonNet Config or the application's help for more details.

Starting on Windows

- Windows 10/Windows Server 2016

Click the start button, and then select **EpsonNet > EpsonNet Config**.

- Windows 8.1/Windows 8/Windows Server 2012 R2/Windows Server 2012

Enter the application name in the search charm, and then select the displayed icon.

- Windows 7/Windows Vista/Windows XP/Windows Server 2008 R2/Windows Server 2008/Windows Server 2003 R2/Windows Server 2003

Click the start button, and select **All Programs** or **Programs > EpsonNet > EpsonNet Config SE > EpsonNet Config**.

Starting on Mac OS

Go > Applications > Epson Software > EpsonNet > EpsonNet Config SE > EpsonNet Config.

Software Update Tools (EPSON Software Updater)

EPSON Software Updater is an application that checks for new or updated software on the internet and installs it. You can also update the printer's firmware and manual.

Note:

Windows Server operating systems are not supported.

Installing Method

Download EPSON Software Updater from the Epson website.

If you are using a Windows computer and cannot to download it from the website, you can install it from the supplied software disc.

<http://www.epson.com>

Starting on Windows

- Windows 10

Click the start button, and then select **Epson Software > EPSON Software Updater**.

- Windows 8.1/Windows 8

Enter the application name in the search charm, and then select the displayed icon.

Network Service and Software Information

- ❑ Windows 7/Windows Vista/Windows XP

Click the start button, and then select **All Programs** or **Programs > Epson Software > EPSON Software Updater**.

Note:

You can also start EPSON Software Updater by clicking the printer icon on the task bar on the desktop, and then selecting **Software Update**.

Starting on Mac OS

Select **Go > Applications > Epson Software > EPSON Software Updater**.

Installing the Latest Applications

Note:

When reinstalling an application, you need to uninstall it first.

1. Make sure the printer and the computer are available for communication, and the printer is connected to the Internet.
2. Start EPSON Software Updater.

The screenshot is an example on Windows.

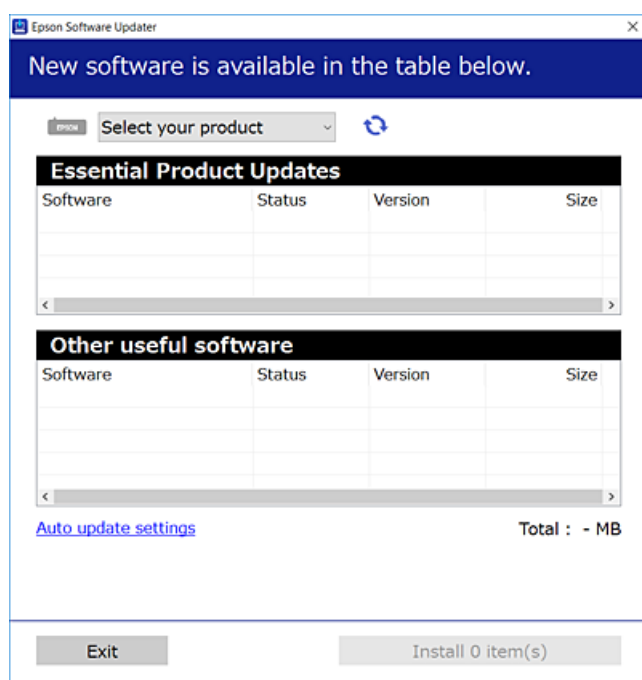

3. For Windows, select your printer, and then click  to check for the latest available applications.
4. Select the items you want to install or update, and then click the install button at the lower right of the screen.



Important:

Do not turn off or unplug the printer until the update is complete; otherwise, the printer may malfunction.

Network Service and Software Information

Note:

- You can download the latest applications from the Epson website.
<http://www.epson.com>
- If you use Windows Server operating systems, you cannot use Epson Software Updater. Download the latest applications from the Epson website.
- Document Capture Pro cannot be installed from Epson Software Updater. Install it from the website below.
<http://support.epson.net/> (outside Europe)
http://assets.epson-europe.com/gb/en/document_capture_pro/index.html (Europe)

Related Information

- ➔ “Software Update Tools (EPSON Software Updater)” on page 242

Installing a PostScript Printer Driver

Installing a PostScript Printer Driver - Windows

1. Start the installation process from one of the following options.
 - Use the software disc supplied with the printer.**

Insert the software disc into the computer, access the following folder path, and then run SETUP64.EXE (or SETUP.EXE).

Driver\PostScript\WINX64 (or WINX86)\SETUP\SETUP64.EXE (or SETUP.EXE)
 - Use the website.**

Access your printer page from the following website, download the PostScript3 printer driver, and then run the execution file.

<http://www.epson.eu/Support> (Europe)
<http://support.epson.net/> (outside Europe)
2. Select your printer.
3. Follow the on-screen instructions.
4. Select the connection method from the network connection or USB connection.
 - For network connection.**

A list of available printers in the same network is displayed.
Select the printer you want to use.
 - For USB connection.**

Follow the on-screen instructions to connect the printer to the computer.
5. Follow the on-screen instructions to install the PostScript printer driver.

Installing a PostScript Printer Driver - Mac OS

Download the printer driver from the Epson Support website, and then install it.

Network Service and Software Information

<http://www.epson.eu/Support> (Europe)

<http://support.epson.net/> (outside Europe)

You need the IP address of the printer while installing the printer driver.

Select the network icon on the printer's home screen, and then select the active connection method to confirm the printer's IP address.

Adding the Printer Driver (for Mac OS Only)

1. Select **System Preferences** from the  menu > **Printers & Scanners** (or **Print & Scan, Print & Fax**).
2. Click +, and then select **Add Other Printer or Scanner**.
3. Select your printer, and then click **Add**.

Note:

- If your printer is not listed, check that it is correctly connected to the computer and that the printer is on.
- For a USB, IP, or Bonjour connection, set the optional paper cassette unit manually after adding the printer driver.

Installing the Epson Universal Printer Driver (for Windows Only)

The Epson universal printer driver is the universal PCL6 compatible print driver. Once you install this printer driver*, you can print from every Epson printer that supports this printer driver.

- * Since this is a generic printer driver, printing features are limited compared to the printer driver specifically designed for this printer.

Connect the printer to the same network as the computer, and then follow the procedure below to install the printer driver.

1. Download the executable file of the driver from the Epson support website.

<http://www.epson.eu/Support> (Europe only)

<http://support.epson.net/>

2. Double-click the executable file.
3. Follow the on-screen instructions for the rest of the installation.

Note:

If you are using a Windows computer and you cannot download the driver from the website, install it from the software disc that came with the printer. Access "Driver\Universal".

Uninstalling Applications

Log in to your computer as an administrator. Enter the administrator password if the computer prompts you.

Uninstalling Applications - Windows

1. Press the  button to turn off the printer.
2. Quit all running applications.
3. Open **Control Panel**:
 - Windows 10/Windows Server 2016
Click on the start button, and then select **Windows System > Control Panel**.
 - Windows 8.1/Windows 8/Windows Server 2012 R2/Windows Server 2012
Select **Desktop > Settings > Control Panel**.
 - Windows 7/Windows Vista/Windows XP/Windows Server 2008 R2/Windows Server 2008/Windows Server 2003 R2/Windows Server 2003
Click the start button and select **Control Panel**.
4. Open **Uninstall a program** (or **Add or Remove Programs**):
 - Windows 10/Windows 8.1/Windows 8/Windows 7/Windows Vista/Windows Server 2016/Windows Server 2012 R2/Windows Server 2012/Windows Server 2008 R2/Windows Server 2008
Select **Uninstall a program** in **Programs**.
 - Windows XP/Windows Server 2003 R2/Windows Server 2003
Click **Add or Remove Programs**.
5. Select the application you want to uninstall.
You cannot uninstall the printer driver if there is any print jobs. Delete or wait to be printed the jobs before uninstalling.
6. Uninstall the applications:
 - Windows 10/Windows 8.1/Windows 8/Windows 7/Windows Vista/Windows Server 2016/Windows Server 2012 R2/Windows Server 2012/Windows Server 2008 R2/Windows Server 2008
Click **Uninstall/Change** or **Uninstall**.
 - Windows XP/Windows Server 2003 R2/Windows Server 2003
Click **Change/Remove** or **Remove**.

Note:
If the **User Account Control** window is displayed, click **Continue**.
7. Follow the on-screen instructions.

Uninstalling Applications - Mac OS

1. Download the Uninstaller using EPSON Software Updater.
Once you have downloaded the Uninstaller, you do not need to download it again each time you uninstall the application.
2. Press the  button to turn off the printer.

Network Service and Software Information

3. To uninstall the printer driver or PC-FAX driver, select **System Preferences** from the  menu > **Printers & Scanners** (or **Print & Scan, Print & Fax**), and then remove the printer from the enabled printers list.
4. Quit all running applications.
5. Select **Go > Applications > Epson Software > Uninstaller**.
6. Select the application you want to uninstall, and then click **Uninstall**.

**Important:**

The Uninstaller removes all drivers for Epson inkjet printers on the computer. If you use multiple Epson inkjet printers and you only want to delete some drivers, delete all of them first, and then install the necessary printer driver again.

Note:

*If you cannot find the application you want to uninstall in the application list, you cannot uninstall using the Uninstaller. In this situation, select **Go > Applications > Epson Software**, select the application you want to uninstall, and then drag it to the trash icon.*

Printing Using a Network Service

By using Epson Connect service available on the Internet, you can print from your smartphone, tablet PC, or laptop, anytime and practically anywhere. To use this service, you need to register the user and the printer in Epson Connect.

The features available on the Internet are as follows.

 Email Print

When you send an email with attachments such as documents or images to an email address assigned to the printer, you can print that email and the attachments from remote locations such as your home or office printer.

 Epson iPrint

This Application is for iOS and Android, and allows you to print or scan from a smart phone or tablet. You can print documents, images, and websites by sending them directly to a printer on the same wireless LAN.

 Scan to Cloud

This application allows you to send the scanned data you want to print to another printer. You can also upload the scanned data to available Cloud services.

 Remote Print Driver

This is a shared driver supported by Remote Print Driver. When printing using a printer in a remote location, you can print by changing the printer on the usual applications window.

See the Epson Connect web portal for details.

<https://www.epsonconnect.com/>

<http://www.epsonconnect.eu> (Europe only)

Related Information

➔ [“Using Epson iPrint” on page 162](#)

Solving Problems



Checking the Printer Status

Checking Messages on the LCD Screen

If an error message is displayed on the LCD screen, follow the on-screen instructions or the solutions below to solve the problem.

Error Messages	Solutions
Printer error. Turn the power off and on again. If the problem persists, contact Epson Support.	<ul style="list-style-type: none"> <input type="checkbox"/> Remove any paper or protective material in the printer and the paper cassette. If the error message is still displayed after turning the power off and on again, contact Epson support. <input type="checkbox"/> When the following error codes are displayed, check the paper for the maximum number of sheets that can be loaded in each paper source. 000181, 000184
Printer error. Contact Epson Support. Non-printing features are available.	The printer may be damaged. Contact Epson support or an authorised Epson service provider to request repairs. However, non-printing features such as scanning are available.
Printer error. For details, see your documentation.	The printer may be damaged. Contact Epson support or an authorised Epson service provider to request repairs.
Paper out in XX. Load paper. Paper Size: XX/ Paper Type: XX	Load paper, and then insert the paper cassette all the way.
Too many paper cassette units are installed. Turn the power off and uninstall the extra units. See your documentation for details.	You can install up to one optional paper cassette unit. For other optional paper cassette units, uninstall them by following the reverse steps to installation.
Unsupported Paper Cassette Units have been installed. Turn the power off and uninstall. For details, see your documentation.	Unsupported optional paper cassette units have been installed. Uninstall them by following the reverse steps to installation.
Cannot print because XX is out of order. You can print from another cassette.	Turn the power off and on again, and then reinsert the paper cassette. If the error message is still displayed, contact Epson support or an authorised Epson service provider to request repairs.
Maintenance Roller in XX is nearing the end of its service life.	The maintenance rollers need to be replaced periodically. Paper is not fed correctly from the paper cassette or the rear paper feed when it is time for replacement. Contact Epson support or an authorized Epson service provider to request replacement of the maintenance rollers for the paper cassette or the rear paper feed.
Maintenance roller in the XX is at the end of its service life. For details, see your documentation.	Contact Epson support or an authorized Epson service provider to request replacement of the maintenance rollers for the paper cassette or the rear paper feed.
You need to replace Ink Supply Unit(s).	To ensure you receive premium print quality and to help protect your print head, a variable ink safety reserve remains in the ink supply unit when your printer indicates it is time to replace the ink supply unit. Replace to new ink supply units.

Solving Problems

Error Messages	Solutions
Paper Setup Auto Display is set to Off. Some features may not be available. For details, see your documentation.	If Paper Setup Auto Display is disabled, you cannot use AirPrint.
No dial tone is detected.	<p>This problem might be resolved by tapping Settings > General Settings > Fax Settings > Basic Settings > Line Type, and then selecting PBX. If your phone system requires an external access code to get an outside line, set the access code after selecting PBX. Use # (hash) instead of the actual access code when entering an outside fax number. This makes connection more secure.</p> <p>If the error message is still displayed, set the Dial Tone Detection settings to disabled. However, disabling this feature may drop the first digit of a fax number and send the fax to the wrong number.</p>
Failed to receive faxes because the fax data capacity is full. Touch the Job/Status at the bottom of the Home Screen for details.	<p>Received faxes may accumulate without being processed due to the following reasons.</p> <ul style="list-style-type: none"> <input type="checkbox"/> Cannot print because a printer error has occurred. Clear the printer error. To check the details and solutions to the error, press the  button and then select Printer Status. <input type="checkbox"/> Cannot save in the computer or the memory device. To check whether or not received faxes have been saved, press the  button and then select Job Status. To save received faxes, turn on the computer or connect a memory device to the printer.
The combination of the IP address and the subnet mask is invalid. See your documentation for more details.	Enter the correct IP address or default gateway. Contact your network administrator for assistance.
To use cloud services, update the root certificate from the Epson Web Config utility.	Run Web Config, and then update the root certificate.
Check that the printer driver is installed on the computer and that the port settings for the printer are correct.	<p>Make sure the printer port is selected correctly in Property > Port from the Printer menu as follows.</p> <p>Select "USBXXX" for a USB connection, or "EpsonNet Print Port" for a network connection.</p>
Recovery Mode	<p>The printer has started in recovery mode because the firmware update failed. Follow the steps below to try to update the firmware again.</p> <ol style="list-style-type: none"> 1. Connect the computer and the printer with a USB cable. (During recovery mode, you cannot update the firmware over a network connection.) 2. Visit your local Epson website for further instructions.

Related Information

- ➔ [“Contacting Epson Support” on page 322](#)
- ➔ [“Software Update Tools \(EPSON Software Updater\)” on page 242](#)
- ➔ [“Installing the Latest Applications” on page 243](#)

Solving Problems

Error Code on the Status Menu

If a job does not complete successfully, check the error code displayed on the history of each job. You can check the error code by pressing the  button, and then selecting **Job Status**. See the following table to find the problem and its solution.

Code	Problem	Solution
001	The product was turned off by a power failure.	-
101	The memory is full.	<p>Try the methods below to reduce the size of the print job.</p> <ul style="list-style-type: none"> <input type="checkbox"/> Lower the print quality and the resolution. <input type="checkbox"/> Change the format setting. <input type="checkbox"/> Reduce the number of images, letters or fonts used in the print job.
102	Collated printing has failed due to a lack of available memory.	<ul style="list-style-type: none"> <input type="checkbox"/> Select Settings > General Settings > System Administration > Clear Internal Memory Data > PDL Font, Macro, and then clear the fonts and the macros that you have downloaded. <input type="checkbox"/> Try the methods below to reduce the size of the print job. If you do not want to use these methods, try printing one copy at a time. <ul style="list-style-type: none"> <input type="checkbox"/> Lower the print quality and the resolution. <input type="checkbox"/> Change the format setting. <input type="checkbox"/> Reduce the number of images, letters or fonts used in the print job.
103	Printing quality has been lowered due to a lack of available memory.	<p>If you do not want to lower the print quality, try the following methods to reduce the size of the print job.</p> <ul style="list-style-type: none"> <input type="checkbox"/> Change the format setting. <input type="checkbox"/> Reduce the number of images, letters or fonts used in the print job.
104	Reverse printing has failed due to a lack of available memory.	<ul style="list-style-type: none"> <input type="checkbox"/> Select Settings > General Settings > System Administration > Clear Internal Memory Data > PDL Font, Macro, and then clear the fonts and the macros that you have downloaded. <input type="checkbox"/> If you want to print in reverse, try the following methods to reduce the size of the print job. <ul style="list-style-type: none"> <input type="checkbox"/> Lower the print quality and the resolution. <input type="checkbox"/> Change the format setting. <input type="checkbox"/> Reduce the number of images, letters or fonts used in the print job.
106	Cannot print from the computer due to the access control settings.	Contact your printer administrator.

Solving Problems

Code	Problem	Solution
107	User authentication failed. The job has been canceled.	<ul style="list-style-type: none"> <input type="checkbox"/> Make sure that the user name and password are correct. <input type="checkbox"/> Select Settings > General Settings > System Administration > Security Settings > Access Control. Enable the user restriction function, and then allow the job without an authentication information.
108	Confidential job data was deleted when the printer was turned off.	-
109	The received fax was already deleted.	-
110	The job was printed on one side only because the paper loaded does not support double sided printing.	If you want to perform 2-sided printing, load paper that supports 2-sided printing.
111	Available memory is running low.	<p>Try the methods below to reduce the size of the print job.</p> <ul style="list-style-type: none"> <input type="checkbox"/> Lower the print quality and the resolution. <input type="checkbox"/> Change the format setting. <input type="checkbox"/> Reduce the number of images, letters or fonts used in the print job.
120	Cannot communicate with the server that is connected using an open platform.	Make sure there are no errors on the server or the network.
201	The memory is full.	<ul style="list-style-type: none"> <input type="checkbox"/> Print received faxes from Job Status in Job/Status. <input type="checkbox"/> Delete received faxes saved in the inbox from Job Status in Job/Status. <input type="checkbox"/> If you are sending a monochrome fax to a single destination, you can send it by using Direct Send. <input type="checkbox"/> Divide your originals in two or more to send them in several batches.
202	The line was disconnected by the recipient machine.	Wait for a while and then try again.
203	The product cannot detect the dial tone.	<ul style="list-style-type: none"> <input type="checkbox"/> Make sure that the phone cable is connected correctly and the phone line is working. <input type="checkbox"/> When the printer is connected to the PBX or the terminal adapter, change the Line Type setting to PBX. <input type="checkbox"/> Select Settings > General Settings > Fax Settings > Basic Settings > Dial Tone Detection, and then disable the dial tone setting.
204	The recipient machine is busy.	<ul style="list-style-type: none"> <input type="checkbox"/> Wait for a while and then try again. <input type="checkbox"/> Check the recipient's fax number.
205	The recipient machine does not answer.	Wait for a while and then try again.
206	The phone cable is incorrectly connected to the LINE and EXT. port of the product.	Check the connection of the LINE port and the EXT. port of the printer.

Solving Problems

Code	Problem	Solution
207	The product is not connected to the phone line.	Connect the phone cable to the phone line.
208	The fax could not be sent to some of the specified recipients.	Print a Fax Log or Last Transmission report for previous faxes from Fax Report in the Fax menu to check the failed destination. When the Save Failure Data setting is enabled, you can resend a fax from Job Status in Job/Status .
301	There is not enough storage space available to save the data in the memory device.	<ul style="list-style-type: none"> <input type="checkbox"/> Increase the storage space in the memory device. <input type="checkbox"/> Reduce the number of documents. <input type="checkbox"/> Lower the scanning resolution or increase the compression ratio to reduce the size of the scanned image.
302	The memory device is write-protected.	Disable write protection on the memory device.
303	No folder has been created to save the scanned image.	Insert another memory device.
304	The memory device has been removed.	Reinsert the memory device.
305	An error occurred while saving the data to the memory device.	If the external device is accessed from a computer, wait for a while and then try again.
306	The memory is full.	Wait until other ongoing jobs are finished.
311	A DNS error has occurred.	<ul style="list-style-type: none"> <input type="checkbox"/> Select Settings > General Settings > Network Settings > Advanced > TCP/IP, and then check the DNS settings. <input type="checkbox"/> Check the DNS settings for the server, the computer, or the access point.
312	An authentication error has occurred.	Select Settings > General Settings > Network Settings > Advanced > Email Server > Server Settings , and then check the server settings.
313	A communication error has occurred.	<ul style="list-style-type: none"> <input type="checkbox"/> Print a network connection report to check if the printer is connected to the network. <input type="checkbox"/> Select Settings > General Settings > Network Settings > Advanced > Email Server > Server Settings to check the email server settings. You can check the cause of the error by running connection check. <input type="checkbox"/> The authentication method of the settings and the email server may not match. When you select Off as the authentication method, make sure the authentication method of the email server is set to None.
314	The data size exceeds the maximum size for attached files.	<ul style="list-style-type: none"> <input type="checkbox"/> Increase the Attached File Max Size setting in the scan settings. <input type="checkbox"/> Lower the scanning resolution or increase the compression ratio to reduce the size of the scanned image.
315	The memory is full.	Retry after other ongoing jobs are finished.

Solving Problems

Code	Problem	Solution
321	A DNS error has occurred.	<ul style="list-style-type: none"> <input type="checkbox"/> Select Settings > General Settings > Network Settings > Advanced > TCP/IP, and then check the DNS settings. <input type="checkbox"/> Check the DNS settings for the server, the computer, or the access point.
322	An authentication error has occurred.	Check the Location settings.
323	A communication error has occurred.	<ul style="list-style-type: none"> <input type="checkbox"/> Check the Location settings. <input type="checkbox"/> Print a network connection report to check if the printer is connected to the network.
324	A file with the same name already exists in the specified folder.	<ul style="list-style-type: none"> <input type="checkbox"/> Delete the file with the same name. <input type="checkbox"/> Change the file name prefix in File Settings.
325 326	There is not enough storage space available in the specified folder.	<ul style="list-style-type: none"> <input type="checkbox"/> Increase the storage space in the specified folder. <input type="checkbox"/> Reduce the number of documents. <input type="checkbox"/> Lower the scanning resolution or increase the compression ratio to reduce the size of the scanned image.
327	The memory is full.	Wait until other ongoing jobs are finished.
328	The destination was wrong or the destination does not exist.	Check the Location settings.
331	A communication error occurred.	Print a network connection report to check if the printer is connected to the network.
332	There is not enough storage space available to save the scanned image in the destination storage.	Reduce the number of documents.
333	The destination could not be found because the destination information was uploaded to the server before sending the scanned image.	Select the destination again.
334	An error occurred while sending the scanned image.	-
341	A communication error has occurred.	<ul style="list-style-type: none"> <input type="checkbox"/> Check the connections for the printer and the computer. If you are connecting over a network, print a network connection report to check if the printer is connected to the network. <input type="checkbox"/> Make sure that Document Capture Pro is installed on the computer. <input type="checkbox"/> If the problem cannot be cleared, contact your printer administrator.
401	There is not enough storage space available to save the data in the memory device.	Increase the storage space in the memory device.
402	The memory device is write-protected.	Disable write protection on the memory device.
404	The memory device has been removed.	Reinsert the memory device.

Solving Problems

Code	Problem	Solution
405	An error occurred while saving the data to the memory device.	<ul style="list-style-type: none"> <input type="checkbox"/> Reinsert the memory device. <input type="checkbox"/> Use a different memory device on which you have created a folder using the Create a folder to save fax data function.
411	A DNS error has occurred.	<ul style="list-style-type: none"> <input type="checkbox"/> Select Settings > General Settings > Network Settings > Advanced > TCP/IP, and then check the DNS settings. <input type="checkbox"/> Check the DNS settings for the server, the computer, or the access point. <input type="checkbox"/> If the problem cannot be cleared, contact your printer administrator.
412	An authentication error has occurred.	<p>Select Settings > General Settings > Network Settings > Advanced > Email Server > Server Settings, and then check the server settings.</p> <p>If the problem cannot be cleared, contact your printer administrator.</p>
413	A communication error has occurred.	<ul style="list-style-type: none"> <input type="checkbox"/> Select Settings > General Settings > Network Settings > Advanced > Email Server > Server Settings to check the email server settings. You can check the cause of the error by running connection check. <input type="checkbox"/> The authentication method of the settings and the email server may not match. When you select Off as the authentication method, make sure the authentication method of the email server is set to None. <input type="checkbox"/> Print a network connection report to check if the printer is connected to the network. <p>If the problem cannot be cleared, contact your printer administrator.</p>
421	A DNS error has occurred.	<ul style="list-style-type: none"> <input type="checkbox"/> Select Settings > General Settings > Network Settings > Advanced > TCP/IP, and then check the DNS settings. <input type="checkbox"/> Check the DNS settings for the server, the computer, or the access point. <input type="checkbox"/> If the problem cannot be cleared, contact your printer administrator.
422	An authentication error has occurred.	<p>Select Settings > General Settings > Fax Settings > Receive Settings > Save/Forward Settings, and then check the settings of the folder selected in Destination.</p>

Solving Problems

Code	Problem	Solution
423	A communication error has occurred.	<ul style="list-style-type: none"> <input type="checkbox"/> Print a network connection report to check if the printer is connected to the network. <input type="checkbox"/> Select Settings > General Settings > Fax Settings > Receive Settings > Save/Forward Settings, and then check the settings of the folder selected in Destination. <input type="checkbox"/> If the problem cannot be cleared, contact your printer administrator.
425	There is not enough storage space available in the forwarding destination folder.	Increase the storage space in the forwarding destination folder.
428	The destination was wrong or the destination does not exist.	Select Settings > General Settings > Fax Settings > Receive Settings > Save/Forward Settings , and then check the settings of the folder selected in Destination .

Related Information

- ➔ [“Network Settings” on page 61](#)
- ➔ [“Printing Using a Network Service” on page 247](#)
- ➔ [“Available Paper and Capacities” on page 27](#)
- ➔ [“Cannot Save Scanned Images to the Shared Folder” on page 282](#)

Checking the Printer Status - Windows

1. Access the printer driver window.
2. Click **EPSON Status Monitor 3** on the **Maintenance** tab, and then click **Details**.

You can check the printer status, ink levels, and error status.

Note:

*If EPSON Status Monitor 3 is disabled, click **Extended Settings** on the **Maintenance** tab, and then select **Enable EPSON Status Monitor 3**.*

Related Information

- ➔ [“Accessing the Printer Driver” on page 127](#)

Checking the Printer Status - Mac OS

1. Select **System Preferences** from the  menu > **Printers & Scanners** (or **Print & Scan, Print & Fax**), and then select the printer.
2. Click **Options & Supplies > Utility > Open Printer Utility**.
3. Click **EPSON Status Monitor**.

You can check the printer status, ink levels, and error status.

Checking the Software Status

You may be able to clear the problem by updating the software to the latest version. To check the software status, use the software update tool.

Related Information

- ➔ [“Software Update Tools \(EPSON Software Updater\)” on page 242](#)
- ➔ [“Installing the Latest Applications” on page 243](#)

Removing Jammed Paper

Follow the on-screen instructions on the printer's control panel to locate and remove the jammed paper including any torn pieces. The LCD screen displays an animation that shows you how to remove jammed paper.

**Caution:**



Never touch the buttons on the control panel while your hand is inside the printer. If the printer starts operating, it could cause an injury. Be careful not to touch the protruding parts to avoid injury.

**Important:**

Remove the jammed paper carefully. Removing the paper vigorously may cause damage to the printer.

Paper Does Not Feed Correctly

Check the following points, and then take the appropriate actions to solve the problem.

- Place the printer on a flat surface and operate in the recommended environmental conditions.
- Use paper supported by this printer.
- Follow the paper handling precautions.
- Do not load more than the maximum number of sheets specified for the paper. When loading plain paper into the paper cassette, do not load above the line indicated by the  symbol on the edge guide. For thick paper such as photo paper, do not load above the line indicated by the  symbol on the edge guide. When loading plain paper into the rear paper feed, do not load above the line indicated by the triangle symbol on the edge guide.
- Make sure the paper size and paper type settings match the actual paper size and paper type loaded in the printer.
- If a paper feed problem frequently occurs, feed paper from another paper source.

Related Information

- ➔ [“Environmental Specifications” on page 301](#)
- ➔ [“Paper Handling Precautions” on page 31](#)
- ➔ [“Available Paper and Capacities” on page 27](#)

Solving Problems

➔ [“List of Paper Type” on page 38](#)

Paper Jams

- Load paper in the correct direction, and slide the edge guides against the edges of the paper.
- Load one sheet of paper at a time if you have loaded several sheets of paper.

Related Information

- ➔ [“Removing Jammed Paper” on page 256](#)
- ➔ [“Loading Paper in the Paper Cassette” on page 32](#)
- ➔ [“Loading Paper in the Rear Paper Feed” on page 34](#)

Paper Feeds at a Slant

Load paper in the correct direction, and slide the edge guides against the edges of the paper.

Related Information

- ➔ [“Loading Paper in the Paper Cassette” on page 32](#)
- ➔ [“Loading Paper in the Rear Paper Feed” on page 34](#)

Several Sheets of Paper are Fed at a Time

When several sheets of paper are fed at a time during manual 2-sided printing, remove any paper which is loaded in the printer before you reload the paper.

Paper Does Not Feed from the Optional Paper Cassette Unit

If you have added optional paper cassette unit, you need to make settings in the printer driver.

Related Information

- ➔ [“Setting the Optional Paper Cassette Unit in the Printer Driver - Windows” on page 313](#)
- ➔ [“Setting the Optional Paper Cassette Unit in the Printer Driver - Mac OS” on page 313](#)

Paper Out Error Occurs

When a paper out error occurs although paper is loaded in the rear paper feed, reload paper in the center of the rear paper feed.

Original Does Not Feed in the ADF

- Use originals supported by the ADF.

Solving Problems

- ❑ Load originals in the correct direction, and slide the ADF edge guides against the edges of the originals.
- ❑ Clean the inside of the ADF.
- ❑ Do not load originals above the line indicated by the triangle symbol on the ADF.

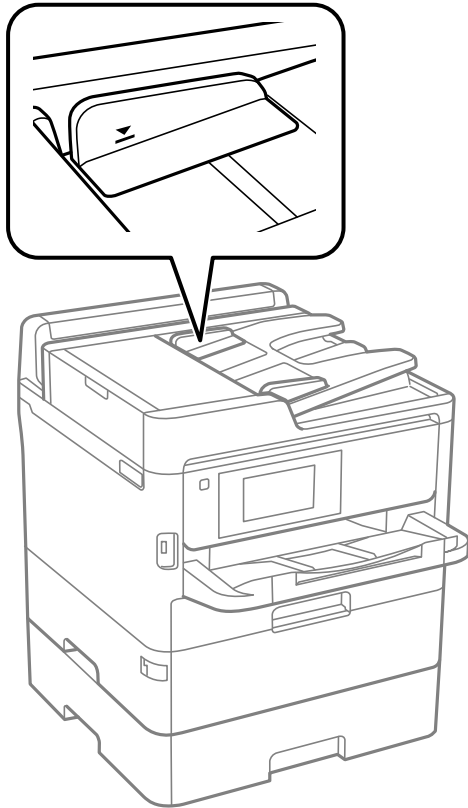

- ❑ Check that the ADF icon is on at the bottom of the screen. If it is off, place the originals again.

Related Information



- ➔ [“Available Originals for the ADF” on page 39](#)
- ➔ [“Placing Originals on the ADF” on page 39](#)
- ➔ [“Cleaning the ADF” on page 233](#)

Power and Control Panel Problems

Power Does Not Turn On

- ❑ Make sure the power cord is securely plugged in.
- ❑ Hold down the  button for a little longer.

Power Does Not Turn Off

Hold down the  button for a little longer. If you still cannot turn off the printer, unplug the power cord. To prevent the print head from drying out, turn the printer back on and turn it off by pressing the  button.

Power Turns Off Automatically

- Select **Settings** > **General Settings** > **Basic Settings** > **Power Off Settings**, and then disable the **Power Off If Inactive** and **Power Off If Disconnected** settings.
- Select **Settings** > **General Settings** > **Basic Settings**, and then disable the **Power Off Timer** setting.

Note:

*Your product may have the **Power Off Settings** or **Power Off Timer** feature depending on the location of purchase.*

LCD Screen Gets Dark

The printer is in sleep mode. Tap anywhere on the LCD screen to return it to its former state.

Touch Screen Does Not Respond

- If you stick a protective label on the touchscreen, the optical touch screen may not respond.
- Turn off the printer, and then wipe the screen using a soft, dry cloth. If the screen is smeared, it may not respond.

Cannot Operate from the Control Panel

When the user feature restriction is enabled, a user ID and password are required to print. If you do not know the password, contact your printer administrator.

Cannot Print from a Computer

Checking the Connection (USB)

- Connect the USB cable securely to the printer and the computer.
- If you are using a USB hub, try to connect the printer directly to the computer.
- If the USB cable cannot be recognized, change the port, or change the USB cable.

Solving Problems

- ❑ If the printer cannot print using a USB connection, try the following.

Disconnect the USB cable from the computer. Right-click on the printer icon displayed on the computer, and then select **Remove Device**. Next, connect the USB cable to the computer and try a test print.

Re-set the USB connection by following the steps in this manual for changing the connection method to a computer. See the related information link below for details.

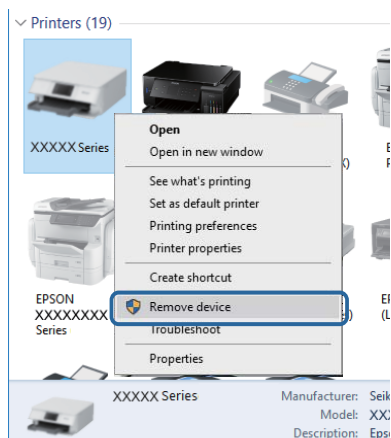

Checking the Connection (Network)

- ❑ When you have changed your access point or provider, try making network settings for the printer again. Connect the computer or smart device to the same SSID as the printer.
- ❑ Turn off the devices you want to connect to the network. Wait for about 10 seconds, and then turn on the devices in the following order; access point, computer or smart device, and then printer. Move the printer and computer or smart device closer to the access point to help with radio wave communication, and then try to make network settings again.
- ❑ Print the network connection report. See the related information link below for details. If the report shows that the network connection failed, check the network connection report and then follow the printed solutions.
- ❑ If the IP address assigned to the printer is 169.254.XXX.XXX, and the subnet mask is 255.255.0.0, the IP address may not be assigned correctly. Restart the access point or reset the network settings for the printer. If this does not solve the problem, see the documentation for the access point.
- ❑ Try accessing any website from your computer to make sure that your computer's network settings are correct. If you cannot access any website, there is a problem on the computer. Check the network connection of the computer.

Related Information

- ➔ [“Printing a Network Connection Report” on page 116](#)

Checking the Software and Data

- ❑ Make sure that a genuine Epson printer driver is installed. If a genuine Epson printer driver is not installed, the available functions are limited. We recommend using a genuine Epson printer driver. See the related information link below for details.
- ❑ If you are printing a large data size image, the computer may run out of memory. Print the image at a lower resolution or a smaller size.

Solving Problems

Related Information

➔ [“Checking for Genuine Epson Printer Drivers” on page 261](#)

Checking for Genuine Epson Printer Drivers

You can check if a genuine Epson printer driver is installed on your computer by using one of the following methods.

Windows

Select **Control Panel > View devices and printers (Printers, Printers and Faxes)**, and then do the following to open the print server properties window.

- ❑ Windows 10/Windows 8.1/Windows 8/Windows 7/Windows Server 2016/Windows Server 2012 R2/Windows Server 2012/Windows Server 2008 R2

Click the printer icon, and then click **Print server properties** at the top of the window.

- ❑ Windows Vista/Windows Server 2008

Right-click on the **Printers** folder, and then click **Run as administrator > Server Properties**.

- ❑ Windows XP/Windows Server 2003 R2/Windows Server 2003

From the **File** menu, select **Server Properties**.

Click the **Driver** tab. If your printer name is displayed in the list, a genuine Epson printer driver is installed on your computer.

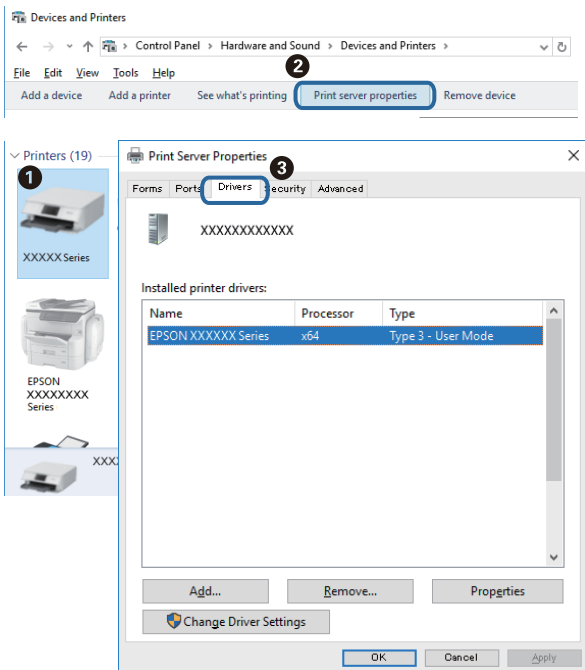

Solving Problems

Mac OS

Select **System Preferences** from the  menu > **Printers & Scanners** (or **Print & Scan, Print & Fax**), and then select the printer. Click **Options & Supplies**, and if the **Options** tab and **Utility** tab are displayed on the window, a genuine Epson printer driver is installed on your computer.



Related Information

➔ [“Installing the Latest Applications” on page 243](#)

Checking the Printer Status from the Computer (Windows)

Click **Print Queue** on the printer driver's **Maintenance** tab, and then check the following.

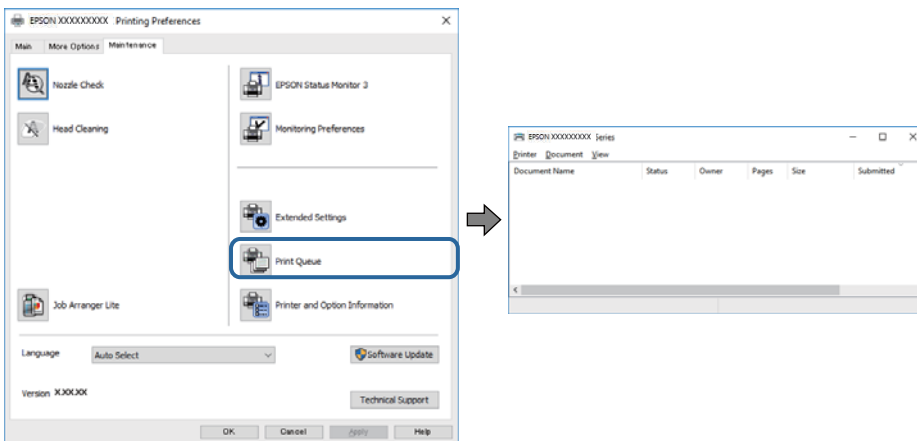

Check if there are any paused print jobs.

If unnecessary data remains, select **Cancel all documents** from the **Printer** menu.

Solving Problems

- ❑ Make sure the printer is not offline or pending.

If the printer is offline or pending, clear the offline or pending setting from the **Printer** menu.

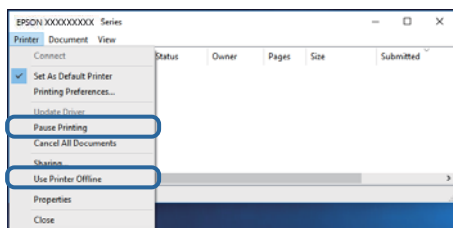

- ❑ Make sure the printer is selected as the default printer from the **Printer** menu (there should be a check mark on the menu item).

If the printer is not selected as the default printer, set it as the default printer. If there are multiple icons in **Control Panel > View devices and printers (Printers, Printers and Faxes)**, see the following to select the icon.

Example)

USB connection: EPSON XXXX Series

Network connection: EPSON XXXX Series (network)

If you install the printer driver multiple times, copies of printer driver may be created. If copies such as "EPSON XXXX Series (copy 1)" are created, right-click the copied driver icon, and then click **Remove Device**.

- ❑ Make sure the printer port is selected correctly in **Property > Port** from the **Printer** menu as follows. Select "USBXXX" for a USB connection, or "EpsonNet Print Port" for a network connection.

Checking the Printer Status from the Computer (Mac OS)

- ❑ The printer may not print when the user feature restriction is enabled. Contact your printer administrator.
- ❑ Make sure the printer status is not **Pause**.

Select **System Preferences** from the  menu > **Printers & Scanners** (or **Print & Scan, Print & Fax**), and then double-click the printer. If the printer is paused, click **Resume** (or **Resume Printer**).

When You Cannot Make Network Settings

- ❑ Turn off the devices you want to connect to the network. Wait for about 10 seconds, and then turn on the devices in the following order; access point, computer or smart device, and then printer. Move the printer and computer or smart device closer to the access point to help with radio wave communication, and then try to make network settings again.
- ❑ Select **Settings > General Settings > Network Settings > Connection Check**, and then print the network connection report. If an error has occurred, check the network connection report and then follow the printed solutions.

Related Information

- ➔ [“Printing a Network Connection Report” on page 116](#)
- ➔ [“Messages and Solutions on the Network Connection Report” on page 117](#)

Solving Problems

Cannot Connect from Devices Even Though Network Settings are No Problems

If you cannot connect from the computer or smart device to the printer even though the network connection report does not show any problems, see the following.

- ❑ When you are using multiple wireless routers at the same time, you may not be able to use the printer from the computer or smart device depending on the settings of the wireless routers. Connect the computer or smart device to the same wireless router as the printer.

Disable the tethering function on the smart device if it is enabled.

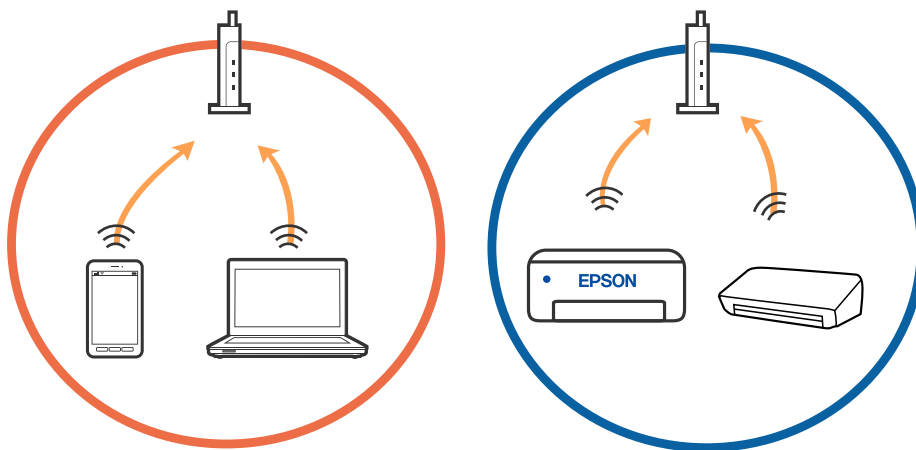

- ❑ You may not be able to connect to the wireless router when the wireless router has multiple SSIDs and devices are connected to different SSIDs on the same wireless router. Connect the computer or smart device to the same SSID as the printer.

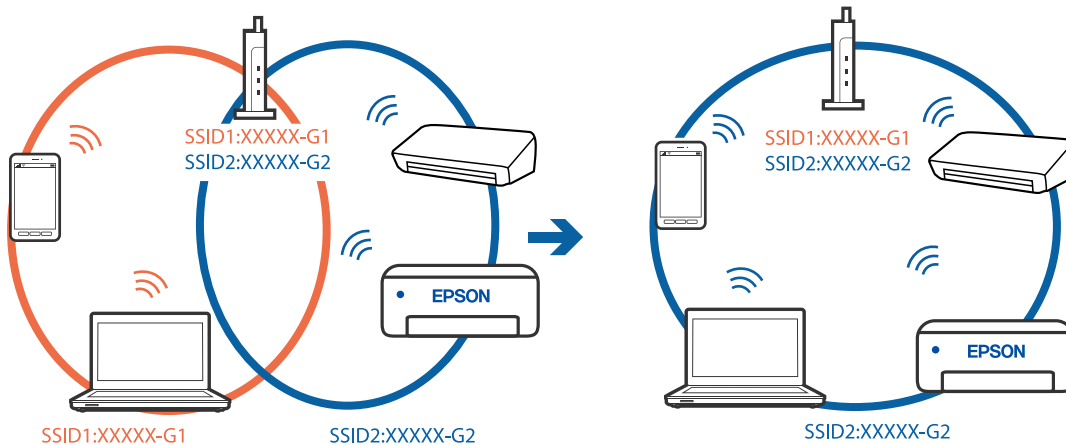

Solving Problems

- ❑ A wireless router that is compliant with both IEEE802.11a and IEEE802.11g has SSIDs of 2.4 GHz and 5 GHz. If you connect the computer or smart device to a 5 GHz SSID, you cannot connect to the printer because the printer only supports communication over 2.4 GHz. Connect the computer or smart device to the same SSID as the printer.

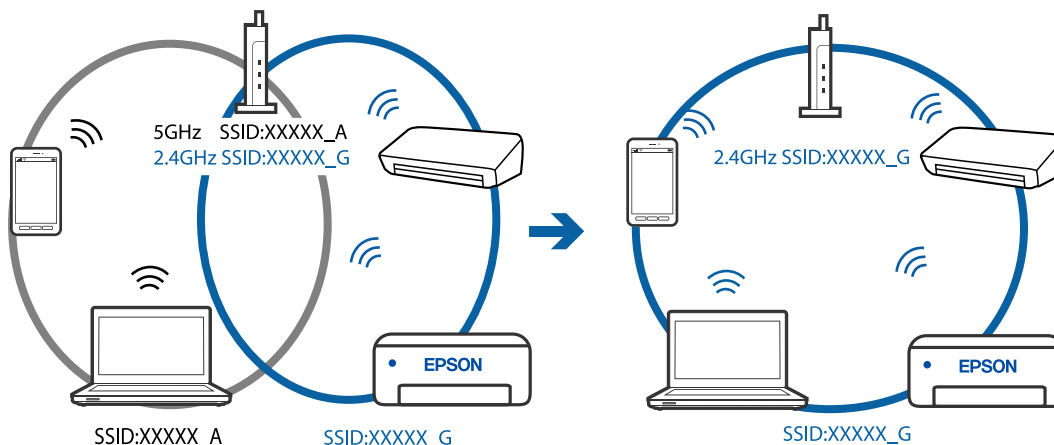

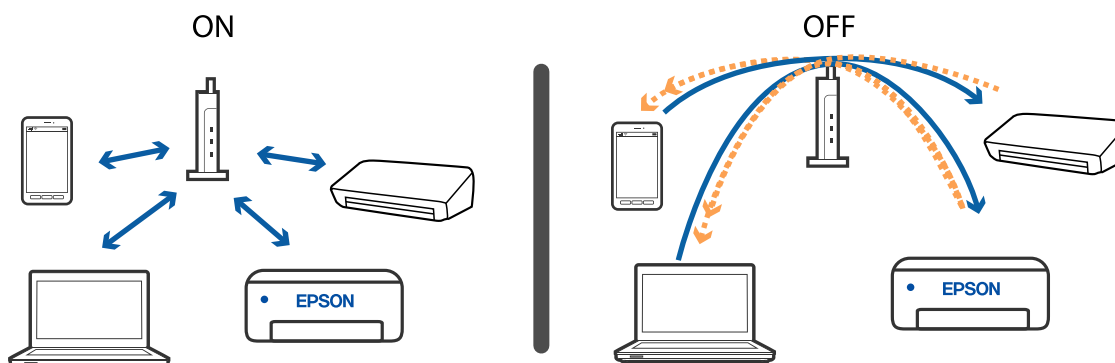

- ❑ Most wireless routers have a privacy separator feature that blocks communication between connected devices. If you cannot communicate between the printer and the computer or smart device even if they are connected to the same network, disable the privacy separator on the wireless router. See the manual provided with the wireless router for details.



Related Information

- ➔ [“Checking the SSID Connected to the Printer” on page 265](#)
- ➔ [“Checking the SSID for the Computer” on page 266](#)

Checking the SSID Connected to the Printer

Tap   on the home screen, and then tap Router or Wi-Fi Direct. SSIDs are displayed in the Wi-Fi or Wi-Fi Direct network.

Checking the SSID for the Computer

Windows

Click  in the task tray on the desktop. Check the name of the connected SSID from the list displayed.



Mac OS

Click the Wi-Fi icon at the top of the computer screen. A list of SSIDs is displayed and the connected SSID is indicated with a check mark.



Cannot Print from an iPhone or iPad

- Connect the iPhone or iPad to the same network (SSID) as the printer.
- Enable **Paper Setup Auto Display** in the following menus.
Settings > General Settings > Printer Settings > Paper Source Settings > Paper Setup Auto Display
- Enable the AirPrint setting on Web Config.

Related Information

- ➔ [“Application for Configuring Printer Operations \(Web Config\)” on page 237](#)

Printout Problems

Adjusting the Print Quality

If you notice a misaligned vertical lines, blurred images, or horizontal banding, adjust the print quality. If you want to adjust the print quality per paper, make this setting first. The setting value per paper is reset if you make this setting after adjusting per paper.

1. Load A4-size plain paper in the printer.
2. Select **Settings** on the home screen.
3. Select **Maintenance > Print Quality Adjustment**.
4. Follow the on-screen instructions to check the printer to improve print quality.
If a message is displayed recommending that you clean the print head, perform print head cleaning.

Solving Problems

5. Follow the on-screen instructions to print the patterns for print head alignment, and then align the print head.
 - This pattern allows you to perform alignment if vertical ruled lines appear misaligned or your printouts look blurry.
 - Find and select the number for the most solid pattern in each group.

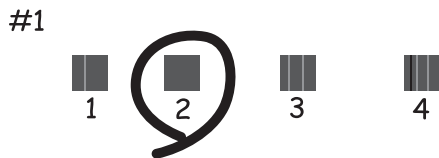

- Find and enter the number for the pattern that has the least misaligned vertical line.

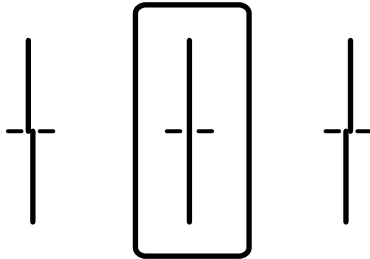

- This pattern allows you to perform alignment if you see horizontal banding at regular intervals. Find and enter the number for the least separated and overlapping pattern.

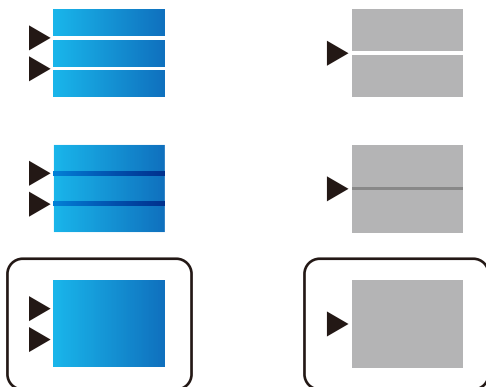

Related Information

➔ [“Loading Paper in the Paper Cassette” on page 32](#)

Adjusting Print Quality per Paper

Making the print quality settings per paper. Plain paper, recycle paper, high quality plain paper, preprinted paper, color paper, letterhead paper, and thick paper is supported.

1. Load paper which you want to adjust the print quality in the printer.

Solving Problems

2. Select **Settings** on the home screen on the printer's control panel.
3. Select **Maintenance > Print Quality Adjustment per Paper**.
If the item is not displayed, flick the screen upward to display it.
4. Select how to adjust from **Print Pattern** or **Enter Set Value**.
5. Select the paper type you loaded in the printer.
6. Follow the on-screen instructions to align the print head.
This pattern aligns if you see horizontal banding at regular intervals.
Find and enter the number for the least separated and overlapping pattern.

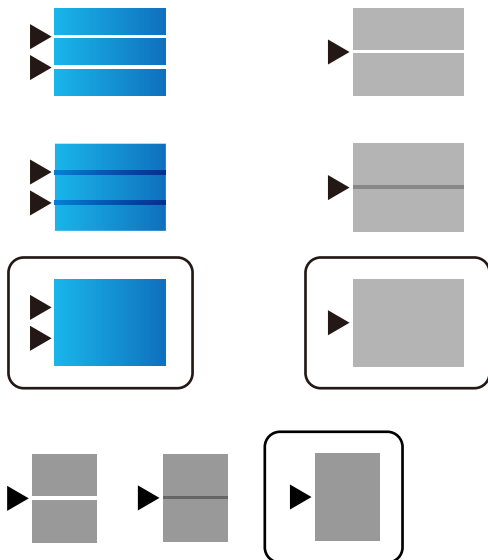

Note:

When you print the paper that can be adjusted the quality, select **Auto Select (plain papers)** on **Paper Type** for printer driver, so adjustment value is automatically applied.

7. Close the information screen.
If the print quality is not improved after performing this adjustment, perform **Print Quality Adjustment** to set the standard adjustment values, and then perform adjustments again according to the paper type.

Printout is Scuffed or Color is Missing

If you have not used the printer for a long time, the print head nozzles may be clogged and ink drops may not be discharged. Perform a nozzle check, and then clean the print head if any of the print head nozzles are clogged.

Related Information

➔ [“Checking and Cleaning the Print Head” on page 231](#)

Banding or Unexpected Colors Appear

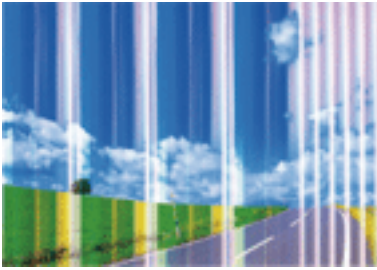

The print head nozzles may be clogged. Perform a nozzle check to check if the print head nozzles are clogged. Clean the print head if any of the print head nozzles are clogged.

Related Information

➔ [“Checking and Cleaning the Print Head” on page 231](#)

Colored Banding Appears at Intervals of Approximately 3.3 cm

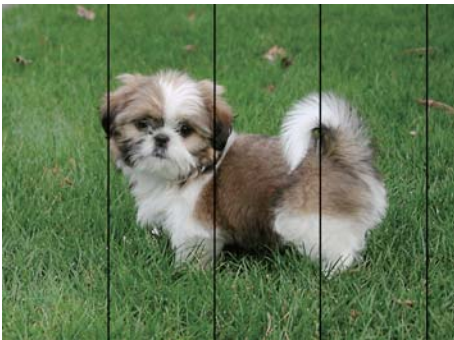

- Select the appropriate paper type setting for the type of paper loaded in the printer.
- Align the print head using the **Print Quality Adjustment** feature.
- When printing on plain paper, print using a higher quality setting.

Related Information

- ➔ [“List of Paper Type” on page 38](#)
- ➔ [“Adjusting the Print Quality” on page 267](#)

Blurry Prints, Vertical Banding, or Misalignment



enthalten alle
Aufdruck. W
5008 "Regel

Align the print head using the **Print Quality Adjustment** feature.

Related Information

➔ [“Adjusting the Print Quality” on page 267](#)

Print Quality Does Not Improve Even After Aligning the Print Head

During bidirectional (or high speed) printing, the print head prints while moving in both directions, and vertical lines may be misaligned. If print quality does not improve, disable the bidirectional (or high speed) setting. Disabling this setting may slow down printing speed.

Control panel

Disable **Bidirectional** in **Settings > General Settings > Printer Settings**.

Windows

Clear **High Speed** on the printer driver's **More Options** tab.

Mac OS

Select **System Preferences** from the  menu > **Printers & Scanners** (or **Print & Scan, Print & Fax**), and then select the printer. Click **Options & Supplies > Options** (or **Driver**). Select **Off** as the **High Speed Printing** setting.

Related Information

➔ [“Menu Options for Memory Device” on page 160](#)

Print Quality is Poor

Check the following if the print quality is poor due to blurry prints, banding, missing colors, faded colors, and misalignment in the prints.

Checking the printer

Use the **Print Quality Adjustment** feature.

- Perform a nozzle check, and then clean the print head if any of the print head nozzles are clogged.
- Align the print head.

Solving Problems

Checking the paper

- Use paper supported by this printer.
- Do not print on paper that is damp, damaged, or too old.
- If the paper is curled or the envelope is puffed up, flatten it.
- Do not stack the paper immediately after printing.
- Dry the printouts completely before filing or displaying them. When drying the printouts, avoid direct sun light, do not use a dryer, and do not touch the printed side of paper.
- When printing images or photos, Epson recommends using genuine Epson paper rather than plain paper. Print on the printable side of the genuine Epson paper.

Checking the print settings

- Select the appropriate paper type setting for the type of paper loaded in the printer.
- Print using a higher quality setting.
- If you have selected **Standard-Vivid** as the quality setting on the Windows printer driver, change to **Standard**. If you have selected **Normal-Vivid** as the quality setting on the Mac OS printer driver, change to **Normal**.

Checking the ink supply unit

- Try to use genuine Epson ink supply units. This product is designed to adjust colors based on the use of genuine Epson ink supply units. The use of non-genuine ink supply units may cause print quality to decline.
- Epson recommends using the ink supply unit before the date printed on the package.

Related Information

- ➔ [“Adjusting the Print Quality” on page 267](#)
- ➔ [“Available Paper and Capacities” on page 27](#)
- ➔ [“List of Paper Type” on page 38](#)
- ➔ [“Paper Handling Precautions” on page 31](#)

Paper Is Smearred or Scuffed

- When horizontal banding appears or the top or bottom of the paper is smearred, load paper in the correct direction and slide the edge guides to the edges of the paper.

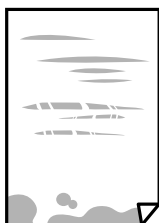

Solving Problems

- ❑ When vertical banding appears or the paper is smeared, clean the paper path.



- ❑ Place the paper on a flat surface to check if it is curled. If it is, flatten it.
- ❑ When printing on thick paper, the print head is close to the printing surface and the paper may be scuffed. In this case, enable the reduce scuff setting. If you enable this setting, print quality may decline or printing may slow down.
 - ❑ Control panel
 - Select **Settings** > **General Settings** > **Printer Settings** from the home screen, and then enable **Thick Paper**.
 - ❑ Windows
 - Click **Extended Settings** on the printer driver's **Maintenance** tab, and then select **Thick Paper and Envelopes**.
 - ❑ Mac OS
 - Select **System Preferences** from the  menu > **Printers & Scanners** (or **Print & Scan**, **Print & Fax**), and then select the printer. Click **Options & Supplies** > **Options** (or **Driver**). Select **On** as the **Thick paper and envelopes** setting.
- ❑ When performing manual 2-sided printing, make sure that the ink is completely dry before reloading the paper.

Related Information

- ➔ [“Loading Paper in the Paper Cassette” on page 32](#)
- ➔ [“Loading Paper in the Rear Paper Feed” on page 34](#)
- ➔ [“Cleaning the Paper Path for Ink Smears” on page 233](#)

Paper is Smeared During Automatic 2-Sided Printing

When using the automatic 2-sided printing feature and printing high density data such as images and graphs, set the print density to lower and the drying time to longer.

Related Information

- ➔ [“Printer Settings” on page 57](#)

Printed Photos are Sticky

You may be printing on the wrong side of the photo paper. Make sure you are printing on the printable side.

When printing on the wrong side of the photo paper, you need to clean the paper path.

Solving Problems

Related Information

- ➔ [“Cleaning the Paper Path for Ink Smears” on page 233](#)

Images or Photos are Printed in Unexpected Colors

When printing from the control panel or from the Windows printer driver, the Epson auto photo adjustment setting is applied by default depending on the paper type. Try change the setting.

- Control panel

Change the **Fix Photo** setting from **Auto** to any other option. If changing the setting does not work, select **Enhance Off** as the **Fix Photo** setting.

- Windows printer driver

On the **More Options** tab, select **Custom** in **Color Correction**, and then click **Advanced**. Change the **Scene Correction** setting from **Auto Correct** to any other option. If changing the setting does not work, use any color correction method other than **PhotoEnhance** in **Color Management**.

Related Information

- ➔ [“Menu Options for Memory Device” on page 160](#)
- ➔ [“Adjusting the Print Color” on page 142](#)

The Position, Size, or Margins of the Printout Are Incorrect

- Load paper in the correct direction, and slide the edge guides against the edges of the paper.
- When placing the originals on the scanner glass, align the corner of the original with the corner indicated by a symbol on the frame of the scanner glass. If the edges of the copy are cropped off, move the original slightly away from the corner.
- When placing the originals on the scanner glass, clean the scanner glass and the document cover. If there is dust or stains on the glass, the copy area may extend to include the dust or stains, resulting in the wrong copying position or small images.
- Select the appropriate **Original Size** in the copy settings.
- Select the appropriate paper size setting.
- Adjust the margin setting in the application so that it falls within the printable area.

Related Information

- ➔ [“Loading Paper in the Paper Cassette” on page 32](#)
- ➔ [“Loading Paper in the Rear Paper Feed” on page 34](#)
- ➔ [“Placing Originals on the Scanner Glass” on page 42](#)
- ➔ [“Cleaning the Scanner Glass” on page 236](#)
- ➔ [“Printable Area” on page 295](#)

Printed Characters Are Incorrect or Garbled

- Connect the USB cable securely to the printer and the computer.

Solving Problems

- If there are any paused print jobs, printed characters may be corrupted.
- Do not put the computer manually into the **Hibernate** mode or the **Sleep** mode while printing. Pages of garbled text may be printed next time you start the computer.
- If you use the printer driver you had previously used, printed characters may be garbled. Make sure that the printer driver you are using is for this printer. Check the printer name on the top of the printer driver window.

The Printed Image Is Inverted

Clear any mirror image settings in the printer driver or the application.

- Windows
 - Clear **Mirror Image** on the printer driver's **More Options** tab.
- Mac OS
 - Clear **Mirror Image** from the print dialog's **Print Settings** menu.

Mosaic-Like Patterns in the Prints

When printing images or photos, print using high-resolution data. Images on websites are often low resolution although they look good enough on the display, and so print quality may decline.

Unintentionally Printing on 2-Sides

Clear any 2-sided printing settings in the printer driver.

- Windows
 - Select **Off** from **2-Sided Printing** on the printer driver's **Main** tab.
- Mac OS
 - Select **Off** from **Two-sided Printing** on the print dialog's **Two-sided Printing Settings** menu.

Uneven Colors, Smears, Dots, or Straight Lines Appear in the Copied Image

- Clean the paper path.
- Clean the scanner glass.
- Clean the ADF.
- Do not press too hard on the original or the document cover when you are placing the originals on the scanner glass.
- When the paper is smeared, lower the copy density setting.

Related Information

- ➔ [“Cleaning the Paper Path for Ink Smears” on page 233](#)
- ➔ [“Cleaning the Scanner Glass” on page 236](#)
- ➔ [“Cleaning the ADF” on page 233](#)

Solving Problems

➔ [“Basic Menu Options for Copying” on page 167](#)

Moiré (Cross-Hatch) Patterns Appear in the Copied Image

Change the reduce and enlarge setting or place the original at a slightly different angle.

Related Information

➔ [“Basic Menu Options for Copying” on page 167](#)

An Image of the Reverse Side of the Original Appears in the Copied Image

- For a thin original, place the original on the scanner glass and then place a piece of black paper over it.
- Lower the copy density setting on the control panel.

Related Information

➔ [“Basic Menu Options for Copying” on page 167](#)

The Printout Problem Could Not be Cleared

If you have tried all of the solutions and have not solved the problem, try uninstalling and then reinstalling the printer driver.

Related Information

- ➔ [“Uninstalling Applications” on page 245](#)
- ➔ [“Installing the Latest Applications” on page 243](#)

Other Printing Problems

Printing Is Too Slow

- Close any unnecessary applications.
- Lower the quality setting. High quality printing slows down the printing speed.

Solving Problems

- ❑ Enable the bidirectional (or high speed) setting. When this setting is enabled, the print head prints while moving in both directions, and the printing speed increases.
 - ❑ Control Panel

From the home screen, select **Settings** > **General Settings** > **Printer Settings** > **Bidirectional**, and then enable it.
 - ❑ Windows

Select **High Speed** on the printer driver's **More Options** tab.
 - ❑ Mac OS

Select **System Preferences** from the  menu > **Printers & Scanners** (or **Print & Scan**, **Print & Fax**), and then select the printer. Click **Options & Supplies** > **Options** (or **Driver**). Select **On** as the **High Speed Printing** setting.
- ❑ Disable quiet mode. This feature slows down the printing speed.
 - ❑ Control Panel

Select  on the home screen, and then disable **Quiet Mode**.
 - ❑ Windows

Select **Off** as the **Quiet Mode** setting on the printer driver's **Main** tab.
 - ❑ Mac OS

Select **System Preferences** from the  menu > **Printers & Scanners** (or **Print & Scan**, **Print & Fax**), and then select the printer. Click **Options & Supplies** > **Options** (or **Driver**). Select **Off** as the **Quiet Mode** setting.
- ❑ For 2-sided printing, one side of paper is printed and dried, and then the other side is printed. Because the drying time differs depending on the environment, such as temperature or humidity, or the print data, the printing speed may be slower.

Printing Slows Down Dramatically During Continuous Printing

Printing slows down to prevent the printer mechanism from overheating and being damaged. However, you can continue printing. To return to normal printing speed, leave the printer idle for at least 30 minutes. Printing speed does not return to normal if the power is off.

Cannot Cancel Printing from a Computer Running Mac OS X v10.6.8

If you want to stop printing from your computer, make the following settings.

Run Web Config, and then select **Port9100** as the **Top Priority Protocol** setting in **AirPrint Setup**. Select **System Preferences** from the  menu > **Printers & Scanners** (or **Print & Scan**, **Print & Fax**), remove the printer, and then add the printer again.

PostScript Printer Driver Problems

Note:

The menu items and text on the printer driver vary depending on your computer's environment.

Printer Does Not Print While Using PostScript Printer Driver

- Set the **Printing Language** setting to **Auto** or **PS3** on the control panel.
- In Windows, if a large number of jobs are sent, the printer may not print. Select **Print directly to the printer** on the **Advanced** tab in the printer properties.

Related Information

➔ [“Printer Settings” on page 57](#)

Printer Does Not Print Correctly While Using PostScript Printer Driver

- If the file is created in an application that allows you to change the data format, such as Adobe Photoshop, make sure that the settings in the application match the settings in the printer driver.
- EPS files made in binary format may not be printed correctly. Set the format to ASCII when making EPS files in an application.
- For Windows, the printer cannot print binary data when it is connected to the computer using a USB interface. Set the **Output Protocol** setting on the **Device Settings** tab in the printer properties to **ASCII** or **TBCP**.
- For Windows, select the appropriate substitution fonts on the **Device Settings** tab in the printer properties.

Print Quality Is Poor While Using PostScript Printer Driver

You cannot make color settings on the **Paper/Quality** tab in the printer driver. Click **Advanced**, and then set the **Color Mode** setting.

Printing Is Too Slow While Using PostScript Printer Driver

Set the **Print Quality** setting to **Fast** in the printer driver.

Cannot Start Scanning

- If you are scanning with the ADF, check that the document cover and ADF cover are closed.
- Connect the USB cable securely to the printer and the computer. If you are using a USB hub, try to connect the printer directly to the computer.
- If you scan at a high resolution over a network, a communication error may occur. Lower the resolution.
- Make sure that the correct printer (scanner) is selected on Epson Scan 2.

Check whether or not the printer is recognized when using Windows

In Windows, make sure the printer (scanner) is displayed in **Scanner and Camera**. The printer (scanner) should be displayed as "EPSON XXXXX (printer name)". If the printer (scanner) is not displayed, uninstall and then re-install Epson Scan 2. See the following to access **Scanner and Camera**.

Solving Problems

❑ Windows 10

Click on the start button, and then select **Windows System > Control Panel**, enter "Scanner and Camera" in the search charm, click **View scanners and cameras**, and then check if the printer is displayed.

❑ Windows 8.1/Windows 8/Windows Server 2012 R2/Windows Server 2012

Select **Desktop > Settings > Control Panel**, enter "Scanner and Camera" in the search charm, click **Show Scanner and Camera**, and then check if the printer is displayed.

❑ Windows 7/Windows Server 2008 R2

Click the start button and select **Control Panel**, enter "Scanner and Camera" in the search charm, click **View scanners and cameras**, and then check if the printer is displayed.

❑ Windows Vista/Windows Server 2008

Click the start button, select **Control Panel > Hardware and Sound > Scanners and Cameras**, and then check if the printer is displayed.

❑ Windows XP/Windows Server 2003 R2/Windows Server 2003

Click the start button, select **Control Panel > Printers and Other Hardware > Scanner and Cameras**, and then check if the printer is displayed.

Related Information

- ➔ [“Uninstalling Applications” on page 245](#)
- ➔ [“Installing the Latest Applications” on page 243](#)

Scanned Image Problems

Uneven Colors, Dirt, Spots, and so on Appear when Scanning from the Scanner Glass

- ❑ Clean the scanner glass.
- ❑ Remove any trash or dirt that adheres to the original.
- ❑ Do not press with too much force on the original or the document cover. If you press with too much force, blurring, smudges, and spots may occur.

Related Information

- ➔ [“Cleaning the Scanner Glass” on page 236](#)

Straight Lines Appear when Scanning from ADF

- ❑ Clean the ADF.
Straight lines may appear in the image when trash or dirt gets into the ADF.
- ❑ Remove any trash or dirt that adheres to the original.

Related Information

- ➔ [“Cleaning the ADF” on page 233](#)

The Image Quality Is Rough

- In Epson Scan 2, adjust the image using items on the **Advanced Settings** tab, and then scan.
- If the resolution is low, try increasing the resolution and then scanning.

Related Information

- ➔ [“Application for Scanning Documents and Images \(Epson Scan 2\)” on page 238](#)

Offset Appears in the Background of Images

Images on the back of the original may appear in the scanned image.

- In Epson Scan 2, select the **Advanced Settings** tab, and then adjust the **Brightness**.
This feature may not be available depending on the settings on the **Main Settings** tab > **Image Type** or other settings on the **Advanced Settings** tab.
- In Epson Scan 2, select the **Advanced Settings** tab, and then **Image Option** > **Text Enhancement**.
- When scanning from the scanner glass, place black paper or a desk pad over the original.

Related Information

- ➔ [“Application for Scanning Documents and Images \(Epson Scan 2\)” on page 238](#)
- ➔ [“Placing Originals” on page 39](#)

Text is Blurred

- In Epson Scan 2, select the **Advanced Settings** tab, and then **Image Option** > **Text Enhancement**.
- In Epson Scan 2, when **Image Type** on the **Main Settings** tab is set to **Black & White**, adjust the **Threshold** on the **Advanced Settings** tab. When you increase the **Threshold**, black becomes stronger.
- If the resolution is low, try increasing the resolution and then scanning.

Related Information

- ➔ [“Application for Scanning Documents and Images \(Epson Scan 2\)” on page 238](#)

Moiré Patterns (Web-Like Shadows) Appear

If the original is a printed document, moiré patterns (web-like shadows) may appear in the scanned image.

- On the **Advanced Settings** tab in Epson Scan 2, set **Descreening**.



Solving Problems

- Change the resolution, and then scan again.

Related Information

- ➔ [“Application for Scanning Documents and Images \(Epson Scan 2\)” on page 238](#)

Cannot Scan the Correct Area on the Scanner Glass

- Make sure the original is placed correctly against the alignment marks.
- If the edge of the scanned image is missing, move the original slightly away from the edge of the scanner glass.
- When scanning from the control panel and selecting the auto scan area cropping function, remove any trash or dirt from the scanner glass and document cover. If there is any trash or dirt around the original, the scanning range expands to include it.

Related Information

- ➔ [“Placing Originals” on page 39](#)
- ➔ [“Cleaning the Scanner Glass” on page 236](#)

Text is Not Recognized Correctly when Saving as a Searchable PDF

- On the **Image Format Options** window in Epson Scan 2, check that **Text Language** is set correctly on the **Text** tab.
- Check that the original is placed straight.
- Use an original with clear text. Text recognition may decline for the following types of originals.
 - Originals that have been copied a number of times
 - Originals received by fax (at low resolutions)
 - Originals on which the letter spacing or line spacing is too small
 - Originals with ruled lines or underlining over the text
 - Originals with hand-written text
 - Originals with creases or wrinkles
- In Epson Scan 2, when **Image Type** on the **Main Settings** tab is set to **Black & White**, adjust the **Threshold** on the **Advanced Settings** tab. When you increase the **Threshold**, the black color area becomes larger.
- In Epson Scan 2, select the **Advanced Settings** tab, and then **Image Option > Text Enhancement**.

Related Information

- ➔ [“Application for Scanning Documents and Images \(Epson Scan 2\)” on page 238](#)

Cannot Solve Problems in the Scanned Image

If you have tried all of the solutions and have not solved the problem, initialize the Epson Scan 2 settings using Epson Scan 2 Utility.

Solving Problems

Note:

Epson Scan 2 Utility is an application that comes with Epson Scan 2.

1. Start Epson Scan 2 Utility.
 - Windows 10/Windows Server 2016
Click the start button, and then select **EPSON > Epson Scan 2 Utility**.
 - Windows 8.1/Windows 8/Windows Server 2012 R2/Windows Server 2012
Enter the application name in the search charm, and then select the displayed icon.
 - Windows 7/Windows Vista/Windows XP/Windows Server 2008 R2/Windows Server 2008/Windows Server 2003 R2/Windows Server 2003
Click the start button, and then select **All Programs** or **Programs > EPSON > Epson Scan 2 > Epson Scan 2 Utility**.
 - Mac OS
Select **Go > Applications > Epson Software > Epson Scan 2 Utility**.
2. Select the **Other** tab.
3. Click **Reset**.

Note:

If initialization does not solve the problem, uninstall and re-install Epson Scan 2.

Related Information

- ➔ [“Uninstalling Applications” on page 245](#)
- ➔ [“Installing the Latest Applications” on page 243](#)

Cannot Save Scanned Images to the Shared Folder

Checking Messages on the Printer

Error messages are displayed on the printer's control panel when an error occurs.

Solving Problems

Messages	Solutions
DNS error. Check DNS settings.	<ul style="list-style-type: none"> <input type="checkbox"/> Make sure that the address in the contacts list on the printer and the address of the shared folder are the same. <input type="checkbox"/> If the IP address of the computer is static and is set manually, change the computer name in the network path to the IP address. Example: \\EPSON02\SCAN to \\192.168.xxx.xxx\SCAN <input type="checkbox"/> Make sure that the computer is turned on and does not sleep. If the computer sleeps, you cannot save scanned images to the shared folder. <input type="checkbox"/> Temporarily disable the computer's Firewall and security software. If this clears the error, check the settings in the security software. <input type="checkbox"/> If Public network is selected as the network place, you cannot save the scanned images to the shared folder. Set the forward settings for each port. <input type="checkbox"/> If you are using a laptop computer and the IP address is set as DHCP, the IP address may change when reconnecting to the network. Obtain the IP address again. <input type="checkbox"/> Make sure the DNS setting is correct. Contact your network administrator about the DNS settings. <input type="checkbox"/> The computer name and the IP address may differ when the management table of the DNS server is not updated. Contact your DNS server administrator.
Authentication error. Check the authentication method, authenticated account, and authenticated password.	Make sure the user name and the password are correct on the computer and the contacts on the printer. Also, make sure that the password has not expired.
Communication error. Check the Wi-Fi/ network connection.	<ul style="list-style-type: none"> <input type="checkbox"/> Make sure that Use Microsoft network sharing is enabled on the Web Config. Select Network > MS Network on the Web Config. <input type="checkbox"/> Make sure that the address in the contacts list on the printer and the address of the shared folder are the same. <input type="checkbox"/> Access rights for the user in the contacts list should be added on the Sharing tab and the Security tab of the shared folder's properties. Also, the permissions for the user should be set to "allowed".
The file name is already in use. Rename the file and scan again.	Change the file name settings. Otherwise, move or delete the files, or change the file name on the shared folder.
Scanned file(s) are too large. Only XX page(s) have been sent. Check if the destination has enough space.	There is not enough disk space on the computer. Increase the free space on the computer.

Checking the Point where the Error Occurred

When saving scanned images to the shared folder, saving process proceeds as following. You can then check the point where the error occurred.

Items	Operation	Error Messages
Connecting	Connect to the computer from the printer.	DNS error. Check DNS settings.
Logging on to the computer	Log on to the computer with the user name and the password.	Authentication error. Check the authentication method, authenticated account, and authenticated password.

Solving Problems

Items	Operation	Error Messages
Checking the folder to save	Check the network path of the shared folder.	Communication error. Check the Wi-Fi/network connection.
Checking the file name	Check if there is a file with the same name as the file you want to save in the folder.	The file name is already in use. Rename the file and scan again.
Writing the file	Write a new file.	Scanned file(s) are too large. Only XX page(s) have been sent. Check if the destination has enough space.

Saving the Scanned Images Takes a Long Time

Check the following points.

- Make sure the DNS setting is correct.
- Make sure each DNS setting is correct when checking the Web Config.
- Make sure the DNS domain name is correct.

Switch Between Private Network and Public Network

The network place is set as a profile for network connections in Windows 7 or later. Shared settings and firewall settings are set according to the network place.

Use **Private network**, **Home network**, or **Work network** to access the network in the home or the office. To access public wireless LANs such as in an airport or a station, use a **Public network**, which is safer than a private network.

Use **Private network**, **Home Network**, or **Work network** to save the scanned images to the shared folder.

 **Important:**

To change the network place, contact your administrator.

Note:

*Depending on the environment, **Domain Network** will be used as the network place.*

Select the network place when connecting the computer to the network for the first time. You cannot save scanned images to the shared folder when you select the public network as the network place. Set the network place again.

Network place names vary in Windows 10/Windows 8.1/Windows 8 and Windows 7.

Windows 10/Windows 8.1/Windows 8	Private network
	Public network
Windows 7	Home network
	Work network
	Public network

You can check the network settings on the **Control Panel > Network and Sharing Center**.

Change the Network Place

Operations for changing the network place vary depending on the operating system.

Related Information

- ➔ [“Changing the Network Place - Windows 10” on page 285](#)
- ➔ [“Changing the Network Place - Windows 8.1” on page 285](#)
- ➔ [“Changing the Network Place - Windows 8” on page 286](#)
- ➔ [“Changing the Network Place - Windows 7” on page 286](#)

Changing the Network Place - Windows 10

Note:

Sign in as the administrator.

1. Click the Windows mark to display the start menu, and then click the setting icon.
2. On the **Settings** window, click **Network and Internet**.
3. On the **Network and Internet** window, click the connected network name.
 - Select **Wi-Fi** when using a wireless connection.
 - Select **Ethernet** when using a wired connection.
4. If many SSIDs are displayed on the window, scroll through the list, and then click **Advanced options**.
5. Set **Make this PC discoverable**. Select **On** to save scanned images to the shared folder.
 - Select **On** (private network) when connecting to a home network or office network.
 - Select **Off** (public network) when connecting to a public network.

Note:

*You can check the network place in the **Network and Sharing Center**.*

Changing the Network Place - Windows 8.1

Note:

Sign in as an administrator.

1. Display the charm by putting the mouse pointer on the bottom-right of the screen, and then click **Settings**.
2. Click **Change PC settings** on the **Settings** window.
3. Click **Network** on the **PC settings** window.
4. Click the connected network on the **Network** window.
5. Set **Find devices and content**. Select **On** to save the scanned images to the shared folder.
 - Select **On** (private network) when connecting to a home network or office network.
 - Select **Off** (public network) when connecting to a public network.

Solving Problems

Note:

- Find devices and content** is displayed when signing in as an administrator.
- You can check the network place on the **Network and Sharing Center**.

Changing the Network Place - Windows 8

Note:

Sign in as the administrator.

1. Display the charm by putting the mouse pointer on the bottom-right of the screen, and then click **Settings**.
2. Click the connected network icon on the **Settings** window.
3. Right-click the connected network on the **Network** window, and then click **Turn sharing on or off** on the displayed menu.
4. **Do you want to turn on sharing between PCs and connect to devices on this network?** is displayed, select the answer suitable to your network place. Select **Yes** to save the scanned images to the shared folder.
 - Select **Yes**(private network) when connecting to a home network or office network.
 - Select **No** (public network) when connecting to a public network.

Note:

You can check the network place on the **Network and Sharing Center**.

Changing the Network Place - Windows 7

Note:

Log on as the administrator.

1. Click the start button, and then select **Control Panel**.
2. Open **Network and Sharing Center**.
 - Category view**: Select **Network and Internet > Network and Sharing Center**.
 - Small icons** view: Click **Network and Sharing Center**.
3. Click the network place in **View your active networks**.
4. Set the network place.
 - Select **Home network** or **Work network** when connecting to a home or office network.
 - Select **Public network** when connecting to a public network.
5. Check the content, and then click **Close**.

Other Scanning Problems

Scanning Speed Is Slow

- ❑ Lower the resolution, and then scan again. When the resolution is high, scanning may take some time.
- ❑ The scanning speed may be reduced depending on the image adjustment features in Epson Scan 2.
- ❑ On the **Configuration** screen which is displayed by clicking the  button in Epson Scan 2, if you set **Quiet Mode** on the **Scan** tab, the scanning speed may be reduced.

Related Information

- ➔ [“Scanning Using Epson Scan 2” on page 186](#)

Cannot Send the Scanned Image by Email

Make sure you have configured the email server settings.

Scanning Stops when Scanning to PDF/Multi-TIFF

- ❑ When scanning using Epson Scan 2, you can continuously scan up to 999 pages in PDF format and up to 200 pages in Multi-TIFF format. When scanning using the control panel, you can continuously scan up to 50 pages in single-sided scanning using the ADF, and up to 100 pages in 2-sided scanning using the ADF and when scanning using the scanner glass.
- ❑ When scanning large volumes, we recommend scanning in grayscale.
- ❑ Increase the free space on the computer's hard disk. Scanning may stop if there is not enough free space.
- ❑ Try scanning at a lower resolution. Scanning stops if the total data size reaches the limit.

Related Information



- ➔ [“Scanning Using Epson Scan 2” on page 186](#)

Problems when Sending and Receiving Faxes

Cannot Send or Receive Faxes

- ❑ Use **Check Fax Connection** on the control panel to run the automatic fax connection check. Try the solutions printed on the report.
- ❑ Check the error code displayed for the failed fax job, and try the solutions described in the error code list.
- ❑ Check the **Line Type** setting. Setting to **PBX** may solve the problem. If your phone system requires an external access code to get an outside line, register the access code to the printer, and enter # (hash) at the beginning of a fax number when sending.
- ❑ If a communication error occurs, change the **Fax Speed** setting to **Slow(9,600bps)** on the control panel.

Solving Problems

- ❑ Check that the telephone wall jack works by connecting a phone to it and testing it. If you cannot make or receive calls, contact your telecommunication company.
- ❑ To connect to a DSL phone line, you need to use a DSL modem equipped with a built-in DSL filter, or install a separate DSL filter to the line. Contact your DSL provider.
- ❑ If you are connecting to a DSL phone line, connect the printer directly to a telephone wall jack to see if the printer can send a fax. If it works, the problem may be caused by the DSL filter. Contact your DSL provider.
- ❑ Enable the **ECM** setting on the control panel. Color faxes cannot be sent or received when **ECM** is off.
- ❑ To send or receive faxes using the computer, make sure that the printer is connected using a USB cable or a network, and that the PC-FAX Driver have been installed on the computer. The PC-FAX Driver is installed together with FAX Utility.
- ❑ In Windows, make sure the printer (fax) is displayed in **Devices and Printers**, **Printer**, or **Printers and Other Hardware**. The printer (fax) is displayed as "EPSON XXXXX (FAX)". If the printer (fax) is not displayed, uninstall and then re-install the FAX Utility. See the following to access **Devices and Printers**, **Printer**, or **Printers and Other Hardware**.
 - ❑ Windows 10/Windows Server 2016
Click on the start button, and then select **Windows System > Control Panel > View devices and printers in Hardware and Sound**.
 - ❑ Windows 8.1/Windows 8
Select **Desktop > Settings > Control Panel > View devices and printers in Hardware and Sound or Hardware**.
 - ❑ Windows 7
Click the start button, and select **Control Panel > View devices and printers in Hardware and Sound or Hardware**.
 - ❑ Windows Vista
Click the start button, and select **Control Panel > Printers in Hardware and Sound**.
 - ❑ Windows XP
Click the start button, and select **Settings > Control Panel > Printers and Other Hardware > Printers and Faxes**.
- ❑ In Mac OS, check the following.
 - ❑ Select **System Preferences** from the  menu > **Printers & Scanners** (or **Print & Scan**, **Print & Fax**), and then make sure the printer (fax) is displayed. The printer (fax) is displayed as "FAX XXXX (USB)" or "FAX XXXX (IP)". If the printer (fax) is not displayed, click [+] and then register the printer (fax).
 - ❑ Select **System Preferences** from the  menu > **Printers & Scanners** (or **Print & Scan**, **Print & Fax**), and then double-click the printer (fax). If the printer is paused, click **Resume** (or **Resume Printer**).

Related Information

- ➔ [“Checking the Status or Logs for Fax Jobs” on page 214](#)
- ➔ [“Connecting to a Phone Line” on page 70](#)
- ➔ [“Basic Settings Menu” on page 94](#)
- ➔ [“Error Code on the Status Menu” on page 250](#)
- ➔ [“Uninstalling Applications” on page 245](#)
- ➔ [“Installing the Latest Applications” on page 243](#)

Solving Problems

Cannot Send Faxes



- ❑ If the user restriction feature has been enabled, a user name and password are required to operate the printer. Contact your administrator if you do not know the password.
- ❑ If the user restriction feature has been enabled, and you send a fax from a computer, user authentication is performed using the user name and password set in the printer driver. When you cannot send a fax due to an authentication error, contact your administrator.
- ❑ Set up the header information for outgoing faxes on the control panel. Some fax machines automatically reject incoming faxes that do not include header information.
- ❑ If you have blocked your caller ID, unblock it. Some phones or fax machines automatically reject anonymous calls.
- ❑ Ask the recipient if the fax number is correct and the recipient's fax machine is ready to receive a fax.
- ❑ Check if you accidentally sent a fax using the subaddress feature. If you select a recipient with a subaddress from the contact list, the fax may be sent using the subaddress feature.
- ❑ When sending faxes using the subaddress feature, ask the recipient if their fax machine is capable of receiving faxes using the subaddress feature.
- ❑ When sending faxes using the subaddress feature, check that the subaddress and password are correct. Check with the recipient that the subaddress and password match.

Related Information

- ➔ [“Cannot Send or Receive Faxes” on page 287](#)
- ➔ [“Sending a Fax with a Subaddress\(SUB\) and Password\(SID\)” on page 199](#)
- ➔ [“Sending Faxes On Demand \(Using Polling Send/Bulletin Board Box\)” on page 194](#)

Cannot Send Faxes to a Specific Recipient

Check the following if you cannot send faxes to a specific recipient due to an error.

- ❑ If the recipient machine does not pick up your call within 50 seconds after the printer has finished dialing, the call ends with an error. Dial using the  (On Hook) feature or using a connected telephone to check how long it takes before you hear a fax tone. If it takes more than 50 seconds, add pauses after the fax number to send the fax. Tap  to enter the pause. A hyphen is entered as the pause mark. One pause is about three seconds. Add multiple pauses as needed.
- ❑ If you have selected the recipient from the contacts list, verify that the registered information is correct. If the information is correct, select the recipient from the contacts list, tap **Edit** and change **Fax Speed** to **Slow(9,600bps)**.

Related Information

- ➔ [“Sending Faxes Manually After Confirming the Recipient's Status” on page 193](#)
- ➔ [“Sending Faxes Dialing from the External Phone Device” on page 194](#)
- ➔ [“Managing Contacts” on page 49](#)
- ➔ [“Cannot Send or Receive Faxes” on page 287](#)

Cannot Send Faxes at a Specified Time

Set the date and the time correctly on the control panel.

Related Information

- ➔ [“Sending Faxes in Monochrome at a Specified Time \(Send Fax Later\)” on page 197](#)
- ➔ [“Basic Settings” on page 55](#)

Cannot Receive Faxes

- If you have subscribed to a call forwarding service, the printer may not be able to receive faxes. Contact the service provider.
- If you have not connected a telephone to the printer, set the **Receive Mode** setting to **Auto** on the control panel.
- Under the following conditions, the printer runs out of memory and cannot receive faxes. See the troubleshooting for information on handling a memory full error.
 - 200 received documents have been saved in the inbox and the confidential box in total.
 - The printer's memory is full (100%).
- When receiving faxes using the subaddress feature, check that the subaddress and password are correct. Check with the sender that the subaddress and password match.
- Check if the sender's fax number has been registered to the **Rejection Number List**. Faxes sent from numbers that have been added to this list are blocked when **Rejection Number List** in **Rejection Fax** is enabled.
- Check if the sender's fax number is registered in the contact list. Faxes sent from numbers that have not been registered to this list are blocked when **Unregistered Contacts** in **Rejection Fax** is enabled.
- Ask the sender if header information is setup on their fax machine. Faxes that do not include header information are blocked when **Fax Header Blank** in **Rejection Fax** is enabled.

Related Information

- ➔ [“Cannot Send or Receive Faxes” on page 287](#)
- ➔ [“Memory Full Error Occurs” on page 290](#)
- ➔ [“Receiving Faxes from a Board with a Subaddress \(SEP\) and Password \(PWD\) \(Polling Receive\)” on page 203](#)

Cannot Save Received Faxes to a Memory Device

Check if the memory device is connected to the printer, and then check the **Receive Settings**.

Memory Full Error Occurs

- If the printer has been set to save received faxes in the inbox or the confidential box, delete faxes you have already read from the inbox or the confidential box.
- If the printer has been set to save received faxes on a computer, turn on the computer that is set to save the faxes. Once the faxes are saved in the computer, they are deleted from the printer's memory.

Solving Problems

- ❑ If the printer has been set to save received faxes on a memory device, connect the device, in which you have created a folder to save faxes, to the printer. Once the faxes are saved in the device, they are deleted from the printer's memory. Make sure that the device has enough available memory and is not write protected.
- ❑ Even though the memory is full, you can send a fax by using one of the following solutions.
 - ❑ Send a fax by using the **Direct Send** feature when sending a monochrome fax.
 - ❑ Send a fax by dialing from the external phone device.
 - ❑ Send a fax by using the  (**On Hook**) feature.
 - ❑ Send a fax by dividing your originals into two or more to send them in several batches.
- ❑ If the printer cannot print a received fax due to a printer error, such as a paper jam, the memory full error may occur. Clear the printer problem, and then contact the sender and ask them to send the fax again.

Related Information

- ➔ [“Sending Many Pages of a Monochrome Document \(Direct Send\)” on page 196](#)
- ➔ [“Sending Faxes Dialing from the External Phone Device” on page 194](#)
- ➔ [“Sending Faxes Manually After Confirming the Recipient's Status” on page 193](#)
- ➔ [“Removing Jammed Paper” on page 256](#)

Sent Fax Quality Is Poor

- ❑ Clean the scanner glass.
- ❑ Clean the ADF.
- ❑ Change the **Original Type** setting on the control panel. If your originals contain both text and photos, select **Photo**.
- ❑ Change the **Density** setting on the control panel.
- ❑ If you are not sure about the capabilities of the recipient fax machine, enable the **Direct Send** feature or select **Fine** as the **Resolution** setting.

If you select **Super Fine** or **Ultra Fine** for a monochrome fax, and send the fax without using the **Direct Send** feature, the printer may automatically lower the resolution.
- ❑ Enable the **ECM** setting on the control panel.

Related Information

- ➔ [“Fax Settings” on page 206](#)
- ➔ [“Cleaning the Scanner Glass” on page 236](#)
- ➔ [“Cleaning the ADF” on page 233](#)

Faxes Are Sent at the Wrong Size

- ❑ When sending a fax using the scanner glass, place the original correctly aligning its corner with the origin mark. Select your original size on the control panel.
- ❑ Clean the scanner glass and the document cover. If there is dust or stains on the glass, the scanning area may extend to include the dust or stains, resulting in the wrong scanning position or small images.

Solving Problems

Related Information

- ➔ [“Fax Settings” on page 206](#)
- ➔ [“Placing Originals” on page 39](#)
- ➔ [“Cleaning the Scanner Glass” on page 236](#)

Received Fax Quality Is Poor

- Enable the **ECM** setting on the control panel.
- Contact the sender and ask them to send using a higher quality mode.
- Reprint the received fax. Select **Log** from **Job/Status** to reprint the fax.

Related Information

- ➔ [“Checking the Fax Job History” on page 216](#)

Received Faxes Are Not Printed

- If an error has occurred on the printer, such as a paper jam, the printer cannot print received faxes. Check the printer.
- If the printer has been set to save received faxes in the inbox or the confidential box, the received faxes are not automatically printed. Check the **Receive Settings**.

Related Information

- ➔ [“Checking the Printer Status” on page 248](#)
- ➔ [“Removing Jammed Paper” on page 256](#)

Pages are Blank or only a Small Amount of Text is Printed on the Second Page in Received Faxes

You can print on one page by using the **Delete Print Data After Split** feature in **Split Page Settings**.

Select **Delete Top** or **Delete Bottom** in **Delete Print Data After Split**, and then adjust **Threshold**. Increasing the threshold increases the amount deleted; a higher threshold gives you a higher possibility of printing on one page.

Other Faxing Problems

Cannot Make Calls on the Connected Telephone

Connect the telephone to the **EXT.** port on the printer, and pick up the receiver. If you cannot hear a dial tone through the receiver, connect the phone cable correctly.

Answering Machine Cannot Answer Voice Calls

On the control panel, set the printer's **Rings to Answer** setting to a number higher than the number of rings for your answering machine.

Sender's Fax Number Not Displayed on Received Faxes or the Number Is Wrong

The sender may not have set the fax header information or may have set it incorrectly. Contact the sender.

Other Problems

Slight Electric Shock when Touching the Printer

If many peripherals are connected to the computer, you may feel a slight electric shock when touching the printer. Install a ground wire to the computer that is connected to the printer.

Operation Sounds Are Loud

If operations sounds are too loud, enable **Quiet Mode**. Enabling this feature may reduce printing speed.

Control panel

Select  on the home screen, and then enable **Quiet Mode**.

Windows printer driver

Enable **Quiet Mode** on the **Main** tab.

Mac OS printer driver

Select **System Preferences** from the  menu > **Printers & Scanners** (or **Print & Scan, Print & Fax**), and then select the printer. Click **Options & Supplies** > **Options** (or **Driver**). Select **On** as the **Quiet Mode** setting.

Epson Scan 2

Click the  button to open the **Configuration** window. Next, set the **Quiet Mode** on the **Scan** tab.

The Date and Time Are Incorrect

Set the date and the time correctly on the control panel. After a power failure caused by a lightning strike or if the power is left off for a long time, the clock may show the wrong time.

Related Information

➔ [“Basic Settings” on page 55](#)

Memory Device Is not Recognized

Enable the memory device in the **Memory Device Interface** settings on the control panel.

Related Information

➔ [“Printer Settings” on page 57](#)

Cannot Save Data to a Memory Device

- Check that the memory device is not write protected.
- Check that the memory device has enough available memory. If the available memory is low, data cannot be saved.

Related Information

➔ [“External USB Device Specifications” on page 299](#)

Forgot Your Password

If you forget the administrator's password, contact Epson support.

Related Information

➔ [“Contacting Epson Support” on page 322](#)

Application Is Blocked by a Firewall (for Windows Only)

Add the application to the Windows Firewall allowed program in security settings on the **Control Panel**.

"x" Is Displayed on the Photo Selection Screen

"x" is displayed on the LCD screen when the image file is not supported by the product.

Related Information

➔ [“Supported Data Specifications” on page 300](#)

Appendix

Technical Specifications

Printer Specifications

Print Head Nozzle Placement		Black ink nozzles: 800 Color ink nozzles: 800 for each color
Weight of Paper *	Plain Paper	64 to 90 g/m ² (17 to 24lb)
	Thick Paper	91 to 256 g/m ² (25 to 68 lb)
	Envelopes	Envelope #10, DL, C6: 75 to 90 g/m ² (20 to 24 lb) Envelope C4: 80 to 100 g/m ² (21 to 26 lb)

* Even when the paper thickness is within this range, the paper may not feed in the printer or print result may adversely affected depending on the paper property or quality.

Printable Area

Print quality may decline in the shaded areas due to the printer's mechanism.

Single sheets

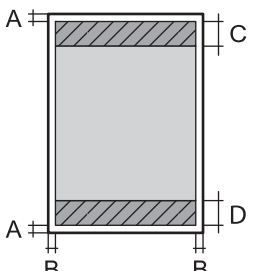
	A	3.0 mm (0.12 in.)
	B	3.0 mm (0.12 in.)
	C	47.0 mm (1.85 in.)
	D	45.0 mm (1.77 in.)

Envelopes

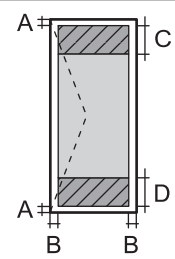
	A	3.0 mm (0.12 in.)
	B	Except for C4: 5.0 mm (0.20 in.) C4: 9.5 mm (0.37 in.)
	C	18.0 mm (0.71 in.)
	D	47.0 mm (1.85 in.)

Appendix

Scanner Specifications

Scanner Type	Flatbed
Photoelectric Device	CIS
Effective Pixels	10200×14040 pixels (1200 dpi)
Maximum Document Size	216×297 mm (8.5×11.7 in.) A4, Letter
Scanning Resolution	1200 dpi (main scan) 2400 dpi (sub scan)
Output Resolution	50 to 9600 dpi in 1 dpi increments
Color Depth	<p>Color</p> <ul style="list-style-type: none"> <input type="checkbox"/> 48 bits per pixel internal (16 bits per pixel per color internal) <input type="checkbox"/> 24 bits per pixel external (8 bits per pixel per color external) <p>Grayscale</p> <ul style="list-style-type: none"> <input type="checkbox"/> 16 bits per pixel internal <input type="checkbox"/> 8 bits per pixel external <p>Black and white</p> <ul style="list-style-type: none"> <input type="checkbox"/> 16 bits per pixel internal <input type="checkbox"/> 1 bits per pixel external
Light Source	LED

Interface Specifications

For Computer	Hi-Speed USB
For External USB Device	Hi-Speed USB

Fax Specifications

Fax Type	Walk-up black-and-white and color fax capability (ITU-T Super Group 3)
Supported Lines	Standard analogue telephone lines, PBX (Private Branch Exchange) telephone systems
Speed	Up to 33.6 kbps

Appendix

Resolution	Monochrome <input type="checkbox"/> Standard: 8 pel/mm×3.85 line/mm (203 pel/in.×98 line/in.) <input type="checkbox"/> Fine: 8 pel/mm×7.7 line/mm (203 pel/in.×196 line/in.) <input type="checkbox"/> Super Fine: 8 pel/mm×15.4 line/mm (203 pel/in.×392 line/in.) <input type="checkbox"/> Ultra Fine: 16 pel/mm×15.4 line/mm (406 pel/in.×392 line/in.) Color 200×200 dpi
Page Memory	Up to 550 pages (when received ITU-T No.1 chart in monochrome draft mode)
Redial*	2 times (with 1 minute intervals)
Interface	RJ-11 Phone Line, RJ-11 Telephone set connection

* The specifications may differ by country or region.

Network Function List

Network Functions and IPv4/IPv6

Functions			Supported	Remarks
Network Printing	EpsonNet Print (Windows)	IPv4	✓	-
	Standard TCP/IP (Windows)	IPv4, IPv6	✓	-
	WSD Printing (Windows)	IPv4, IPv6	✓	Windows Vista or later
	Bonjour Printing (Mac OS)	IPv4, IPv6	✓	-
	IPP Printing (Windows, Mac OS)	IPv4, IPv6	✓	-
	UPnP Printing	IPv4	-	Information appliance
	PictBridge Printing (Wi-Fi)	IPv4	-	Digital camera
	Epson Connect (Email Print, Remote Print)	IPv4	✓	-
	AirPrint (iOS, Mac OS)	IPv4, IPv6	✓	iOS 5 or later, Mac OS X v10.7 or later
	Google Cloud Print	IPv4, IPv6	✓	-

Appendix

Functions		Supported	Remarks	
Network Scanning	Epson Scan 2	IPv4, IPv6	✓	-
	Event Manager	IPv4	-	-
	Epson Connect (Scan to Cloud)	IPv4	✓	-
	AirPrint (Scan)	IPv4, IPv6	✓	OS X Mavericks or later
	ADF (2-sided scanning)		✓	-
Fax	Send a fax	IPv4	✓	-
	Receive a fax	IPv4	✓	-
	AirPrint (Faxout)	IPv4, IPv6	✓	OS X Mountain Lion or later

Wi-Fi Specifications

Standards	IEEE802.11b/g/n ^{*1}
Frequency Range	2.4 GHz
Maximum Radio-Frequency Power Transmitted	20 dBm (EIRP)
Coordination Modes	Infrastructure, Wi-Fi Direct (Simple AP) ^{*2*3}
Wireless Securities ^{*4}	WEP (64/128bit), WPA2-PSK (AES) ^{*5}

*1 IEEE802.11n is only available for the HT20.

*2 Not supported for IEEE 802.11b.

*3 Simple AP mode is compatible with a Wi-Fi connection (infrastructure) or an Ethernet connection.

*4 Wi-Fi Direct supports WPA2-PSK (AES) only.

*5 Complies with WPA2 standards with support for WPA/WPA2 Personal.

Ethernet Specifications

Standards	IEEE802.3i (10BASE-T) ^{*1} IEEE802.3u (100BASE-TX) IEEE802.3ab (1000BASE-T) ^{*1} IEEE802.3az (Energy Efficient Ethernet) ^{*2}
Communication Mode	Auto, 10 Mbps Full duplex, 10 Mbps Half duplex, 100 Mbps Full duplex, 100 Mbps Half duplex
Connector	RJ-45

Appendix

- *1 Use a category 5e or higher STP (Shielded twisted pair) cable to prevent risk of radio interference.
- *2 The connected device should comply with IEEE802.3az standards.

Security Protocol

IEEE802.1X*	
IPsec/IP Filtering	
SSL/TLS	HTTPS Server/Client
	IPPS
SMTPS (STARTTLS, SSL/TLS)	
SNMPv3	

- * You need to use a device for connection that complies with IEEE802.1X.

PostScript Level 3 Compatibility

The PostScript used on this printer is compatible with PostScript Level 3.

Supported Third Party Services

AirPrint	Print	iOS 5 or later/Mac OS X v10.7.x or later
	Scan	OS X Mavericks or later
	Fax	OS X Mountain Lion or later
Google Cloud Print		

External USB Device Specifications

Devices	Maximum Capacities
USB Flash Drive	2 TB (formatted in FAT, FAT32, or exFAT.)

You cannot use the following devices:

- A device that requires a dedicated driver
- A device with security settings (password, encryption, and so on)

Epson cannot guarantee all operations of externally connected devices.

Appendix

Supported Data Specifications

File Format	JPEGs (*.JPG) with the Exif Version 2.31 standard taken by digital cameras DCF* ¹ version 1.0 or 2.0* ² compliant TIFF 6.0 compliant images as below <input type="checkbox"/> RGB full color images (not compressed) <input type="checkbox"/> Binary images (not compressed or CCITT encoded) PDF Version 1.7 compliant data file
Image Size	Horizontal: 80 to 10200 pixels Vertical: 80 to 10200 pixels
File Size	Less than 2 GB
Maximum Number of Files	JPEG: 9990* ³ TIFF: 999 PDF: 999

*1 Design rule for Camera File system.

*2 Photo data stored on digital cameras with a built-in memory is not supported.

*3 Up to 999 files can be displayed at a time. (If the number of files exceeds 999, the files are displayed in groups.)

Note:

"x" is displayed on the LCD screen when the printer cannot recognize the image file. In this situation, if you select a multiple image layout, blank sections will be printed.

Dimensions

Dimensions* ¹	Storage <input type="checkbox"/> Width: 425 mm (16.7 in.) <input type="checkbox"/> Depth: 535 mm (21.1 in.) <input type="checkbox"/> Height: 513 mm (20.2in.) Printing <input type="checkbox"/> Width: 425 mm (16.7 in.) <input type="checkbox"/> Depth: 578 mm (22.8 in.) <input type="checkbox"/> Height: 605 mm (23.8in.)
Weight* ¹ * ²	Approx. 25.8 kg (56.9 lb)

*1 With the output tray and paper cassette 2 installed.

*2 Without the ink supply units and the power cord.

With options

These are the dimensions of printers with 1 optional paper cassette unit.

Appendix

Dimensions	<p>Storage</p> <ul style="list-style-type: none"> <input type="checkbox"/> Width: 425 mm (16.7 in.) <input type="checkbox"/> Depth: 535 mm (21.1 in.) <input type="checkbox"/> Height: 613 mm (24.1 in.) <p>Printing</p> <ul style="list-style-type: none"> <input type="checkbox"/> Width: 425 mm (16.7 in.) <input type="checkbox"/> Depth: 578 mm (22.8 in.) <input type="checkbox"/> Height: 705 mm (27.8 in.)
Weight	Approx. 30.3 kg (66.8 lb)

Electrical Specifications

Model	100 to 240 V Model	220 to 240 V Model
Rated Frequency Range	50 to 60 Hz	50 to 60 Hz
Rated Current	1.1 to 0.6 A	0.6 A
Power Consumption (with USB Connection)	<p>Standalone copying: Approx. 29 W (ISO/IEC24712)</p> <p>Ready mode: Approx. 14 W</p> <p>Sleep mode: Approx. 1.3 W</p> <p>Power off: Approx. 0.2 W</p>	<p>Standalone copying: Approx. 29 W (ISO/IEC24712)</p> <p>Ready mode: Approx. 14 W</p> <p>Sleep mode: Approx. 1.3 W</p> <p>Power off: Approx. 0.2 W</p>

Note:

- Check the label on the printer for its voltage.
- For European users, see the following Website for details on power consumption.

<http://www.epson.eu/energy-consumption>

Environmental Specifications

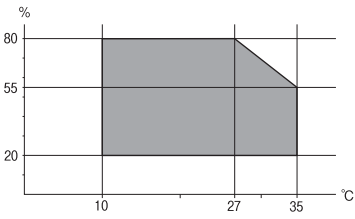
Operation	<p>Use the printer within the range shown in the following graph.</p>  <p>Temperature: 10 to 35°C (50 to 95°F)</p> <p>Humidity: 20 to 80% RH (without condensation)</p>
Storage	<p>Temperature: -20 to 40°C (-4 to 104°F)*</p> <p>Humidity: 5 to 85% RH (without condensation)</p>

Appendix

* You can store for one month at 40°C (104°F).

Environmental Specifications for Ink Supply Units

Storage Temperature	-30 to 40 °C (-22 to 104 °F)*
Freezing Temperature	-13 °C (8.6 °F) Ink thaws and is usable after approximately 5 hours at 25 °C (77 °F).

* You can store for one month at 40 °C (104 °F).

Installation Location and Space

To ensure safe use, place the printer in a location that meets the following conditions.

- A flat, stable surface that can support the weight of the printer
- Well-ventilated location
- Locations that do not block or cover the vents and openings in the printer
- Locations where a dedicated electrical outlet can be secured
- Locations where you can load paper and remove paper easily
- Locations that meet the conditions in the "Environmental Specifications" in this manual



Important:

Do not place the printer in the following locations; otherwise a malfunction may occur.

- Subject to direct sunlight*
- Subject to rapid changes in temperature and humidity*
- Subject to fire*
- Subject to volatile substances*
- Subject to shocks or vibrations*
- Near a television or a radio*
- Near excessive dirt or dust*
- Near water*
- Near air-conditioning or heating equipment*
- Near a humidifier*

Use a commercially available anti-static mat to prevent static generation in locations prone to generating static electricity.

Appendix

Secure enough place to install and operate the printer correctly.

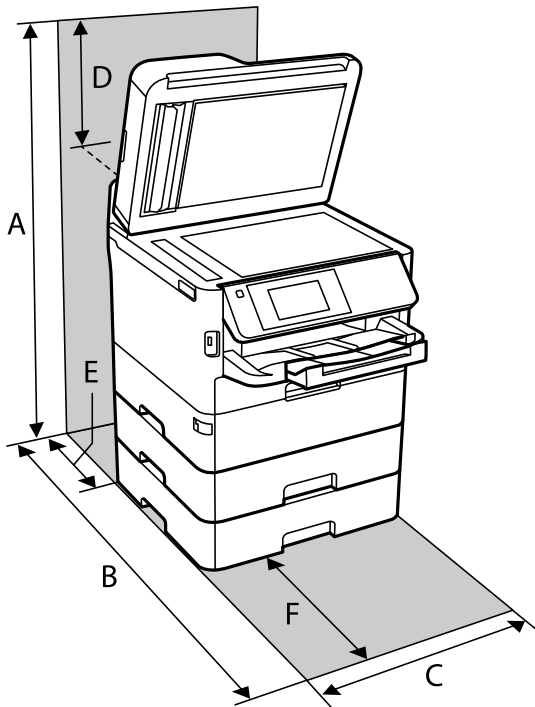

A	872mm
B	848mm
C	425mm
D	259mm
E	79mm
F	370mm

System Requirements

- Windows 10 (32-bit, 64-bit)/Windows 8.1 (32-bit, 64-bit)/Windows 8 (32-bit, 64-bit)/Windows 7 (32-bit, 64-bit)/Windows Vista (32-bit, 64-bit)/Windows XP SP3 or later (32-bit)/Windows XP Professional x64 Edition SP2 or later/Windows Server 2016/Windows Server 2012 R2/Windows Server 2012/Windows Server 2008 R2/Windows Server 2008/Windows Server 2003 R2/Windows Server 2003 SP2 or later
- macOS High Sierra/macOS Sierra/OS X El Capitan/OS X Yosemite/OS X Mavericks/OS X Mountain Lion/Mac OS X v10.7.x/Mac OS X v10.6.8

Note:

- Mac OS may not support some applications and features.
- The UNIX File System (UFS) for Mac OS is not supported.

Font Information

Available Fonts for PostScript

Font Name	Family	HP Equivalent
Nimbus Mono	Medium, Bold, Italic, Bold Italic	Courier
Letter Gothic	Medium, Bold, Italic	Letter Gothic
Nimbus Mono PS	Regular, Bold, Oblique, Bold Oblique	CourierPS
Nimbus Roman No4	Medium, Bold, Italic, Bold Italic	CG Times
URW Classico	Medium, Bold, Italic, Bold Italic	CG Omega
URW Coronet	-	Coronet
URW Clarendon Condensed	-	Clarendon Condensed
URW Classic Sans	Medium, Bold, Italic, Bold Italic	Univers
URW Classic Sans Condensed	Medium, Bold, Italic, Bold Italic	Univers Condensed
Antique Olive	Medium, Bold, Italic	Antique Olive
Garamond	Antiqua, Halbfett, Kursiv, Kursiv Halbfett	Garamond
Mauritius	-	Marigold
Algiers	Medium, Extra Bold	Albertus
NimbusSansNo2	Medium, Bold, Italic, Bold Italic	Arial
Nimbus Roman No9	Medium, Bold, Italic, Bold Italic	Times New Roman
Nimbus Sans	Medium, Bold, Oblique, Bold Oblique	Helvetica
Nimbus Sans Narrow	Medium, Bold, Oblique, Bold Oblique	Helvetica Narrow
Palladio	Roman, Bold, Italic, Bold Italic	Palatino
URW Gothic	Book, Demi, Book Oblique, Demi Oblique	ITC Avant Garde
URW Bookman	Light, Demi, Light Italic, Demi Italic	ITC Bookman
URW Century Schoolbook	Roman, Bold, Italic, Bold Italic	New Century Schoolbook
Nimbus Roman	Medium, Bold, Italic, Bold Italic	Times
URW Chancery Medium Italic	-	ITC Zapf Chancery Italic
Symbol	-	Symbol
URW Dingbats	-	Wingdings
Dingbats	-	ITC Zapf Dingbats
Standard Symbol	-	SymbolPS

Appendix

Available Fonts for PCL (URW)**Scalable Font**

Font Name	Family	HP Equivalent	Symbol Set for PCL5
Nimbus Mono	Medium, Bold, Italic, Bold Italic	Courier	1
Letter Gothic	Medium, Bold, Italic	Letter Gothic	1
Nimbus Mono PS	Regular, Bold, Oblique, Bold Oblique	CourierPS	3
Nimbus Roman No4	Medium, Bold, Italic, Bold Italic	CG Times	2
URW Classico	Medium, Bold, Italic, Bold Italic	CG Omega	3
URW Coronet	-	Coronet	3
URW Clarendon Condensed	-	Clarendon Condensed	3
URW Classic Sans	Medium, Bold, Italic, Bold Italic	Univers	2
URW Classic Sans Condensed	Medium, Bold, Italic, Bold Italic	Univers Condensed	3
Antique Olive	Medium, Bold, Italic	Antique Olive	3
Garamond	Antiqua, Halbfett, Kursiv, Kursiv Halbfett	Garamond	3
Mauritius	-	Marigold	3
Algiers	Medium, Extra Bold	Albertus	3
NimbusSansNo2	Medium, Bold, Italic, Bold Italic	Arial	3
Nimbus Roman No9	Medium, Bold, Italic, Bold Italic	Times New	3
Nimbus Sans	Medium, Bold, Oblique, Bold Oblique	Helvetica	3
Nimbus Sans Narrow	Medium, Bold, Oblique, Bold Oblique	Helvetica Narrow	3
Palladio	Roman, Bold, Italic, Bold Italic	Palatino	3
URW Gothic	Book, Demi, Book Oblique, Demi Oblique	ITC Avant Garde Gothic	3
URW Bookman	Light, Demi, Light Italic, Demi Italic	ITC Bookman	3
URW Century Schoolbook	Roman, Bold, Italic, Bold Italic	New Century Schoolbook	3
Nimbus Roman	Medium, Bold, Italic, Bold Italic	Times	3
URW Chancery Medium Italic	-	ITC Zapf Chancery Medium Italic	3
Symbol	-	Symbol	4
URW Dingbats	-	Wingdings	5
Dingbats	-	ITC Zapf Dingbats	6
Standard Symbol	-	SymbolPS	4

Appendix

Font Name	Family	HP Equivalent	Symbol Set for PCL5
URW David	Medium, Bold	HP David	7
URW Narkis	Medium, Bold	HP Narkis	7
URW Miryam	Medium, Bold, Italic	HP Miryam	7
URW Koufi	Medium, Bold	Koufi	8
URW Naskh	Medium, Bold	Naskh	8
URW Ryadh	Medium, Bold	Ryadh	8

Bitmap Font

Font Name	Symbol Set
Line Printer	9

OCR/Barcode Bitmap Font (for PCL5 only)

Font Name	Family	Symbol Set
OCR A	-	10
OCR B	-	11
Code39	9.37cpi, 4.68cpi	12
EAN/UPC	Medium, Bold	13

Note:

Depending on the print density, or on the quality or color of the paper, OCR A, OCR B, Code39, and EAN/UPC fonts may not be readable. Print a sample and make sure the fonts can be read before printing large quantities.

List of Symbol Sets

Your printer can access a variety of symbol sets. Many of these symbol sets differ only in the international characters specific to each language.

When you are considering which font to use, you should also consider which symbol set to combine with the font.

Note:

Since most software handles fonts and symbols automatically, you will probably never need to adjust the printer's settings. However, if you are writing your own printer control programs, or if you are using older software that cannot control fonts, refer to the following sections for symbol set details.

Appendix

List of Symbol Sets for PCL 5

Symbol Set Name	Attribute	Font Classification												
		1	2	3	4	5	6	7	8	9	10	11	12	13
Norweg1	0D	✓	✓	✓	-	-	-	-	-	-	-	-	-	-
Roman Extension	0E	-	-	-	-	-	-	-	-	✓	-	-	-	-
Italian	0I	✓	✓	✓	-	-	-	-	-	-	-	-	-	-
ECM94-1	0N	✓	✓	✓	-	-	-	-	-	✓	-	-	-	-
Swedis2	0S	✓	✓	✓	-	-	-	-	-	-	-	-	-	-
ANSI ASCII	0U	✓	✓	✓	-	-	-	✓	✓	-	-	-	-	-
UK	1E	✓	✓	✓	-	-	-	-	-	-	-	-	-	-
French2	1F	✓	✓	✓	-	-	-	-	-	-	-	-	-	-
German	1G	✓	✓	✓	-	-	-	-	-	-	-	-	-	-
Legal	1U	✓	✓	✓	-	-	-	-	-	✓	-	-	-	-
8859-2 ISO	2N	✓	✓	✓	-	-	-	-	-	✓	-	-	-	-
Spanish	2S	✓	✓	✓	-	-	-	-	-	-	-	-	-	-
ISO 8859/4 Latin 4	4N	✓	✓	✓	-	-	-	-	-	-	-	-	-	-
Roman-9	4U	✓	✓	✓	-	-	-	-	-	-	-	-	-	-
PsMath	5M	✓	✓	✓	-	-	-	✓	✓	-	-	-	-	-
8859-9 ISO	5N	✓	✓	✓	-	-	-	-	-	✓	-	-	-	-
WiTurkish	5T	✓	✓	✓	-	-	-	-	-	-	-	-	-	-
MsPublishin	6J	✓	✓	✓	-	-	-	-	-	-	-	-	-	-
VeMath	6M	✓	✓	✓	-	-	-	-	-	-	-	-	-	-
8859-10ISO	6N	✓	✓	✓	-	-	-	-	-	✓	-	-	-	-
DeskTop	7J	✓	✓	✓	-	-	-	-	-	-	-	-	-	-
Math-8	8M	✓	✓	✓	-	-	-	✓	✓	-	-	-	-	-
Roman-8	8U	✓	✓	✓	-	-	-	-	-	✓	-	-	-	-
WiE.Europe	9E	✓	✓	✓	-	-	-	-	-	-	-	-	-	-
Pc1004	9J	✓	✓	✓	-	-	-	-	-	-	-	-	-	-
8859-15ISO	9N	✓	✓	✓	-	-	-	-	-	✓	-	-	-	-
PcTk437	9T	✓	✓	✓	-	-	-	-	-	-	-	-	-	-
Windows	9U	✓	✓	✓	-	-	-	-	-	-	-	-	-	-

Appendix

Symbol Set Name	Attribute	Font Classification												
		1	2	3	4	5	6	7	8	9	10	11	12	13
PsText	10J	✓	✓	✓	-	-	-	-	-	-	-	-	-	-
IBM-US	10U	✓	✓	✓	-	-	-	-	-	✓	-	-	-	-
IBM-DN	11U	✓	✓	✓	-	-	-	-	-	✓	-	-	-	-
McText	12J	✓	✓	✓	-	-	-	-	-	-	-	-	-	-
PcMultiling	12U	✓	✓	✓	-	-	-	-	-	✓	-	-	-	-
VeInternati	13J	✓	✓	✓	-	-	-	-	-	-	-	-	-	-
PcEur858	13U	✓	✓	✓	-	-	-	-	-	-	-	-	-	-
VeUS	14J	✓	✓	✓	-	-	-	-	-	-	-	-	-	-
PiFont	15U	✓	✓	✓	-	-	-	-	-	-	-	-	-	-
PcE.Europe	17U	✓	✓	✓	-	-	-	-	-	-	-	-	-	-
Unicode 3.0	18N	✓	✓	✓	-	-	-	✓	✓	-	-	-	-	-
WiBALT	19L	✓	✓	✓	-	-	-	-	-	-	-	-	-	-
WiAnsi	19U	✓	✓	✓	-	-	-	-	-	-	-	-	-	-
PcBlT775	26U	✓	✓	✓	-	-	-	-	-	-	-	-	-	-
Pc866Cyr	3R	✓	✓	-	-	-	-	-	-	-	-	-	-	-
Greek8	8G	✓	✓	-	-	-	-	-	-	-	-	-	-	-
WinGrk	9G	✓	✓	-	-	-	-	-	-	-	-	-	-	-
WinCyr	9R	✓	✓	-	-	-	-	-	-	-	-	-	-	-
Pc851Grk	10G	✓	✓	-	-	-	-	-	-	-	-	-	-	-
ISOCyr	10N	✓	✓	-	-	-	-	-	-	✓	-	-	-	-
Pc8Grk	12G	✓	✓	-	-	-	-	-	-	-	-	-	-	-
ISOGrk	12N	✓	✓	-	-	-	-	-	-	-	-	-	-	-
Pc866Ukr	14R	✓	✓	-	-	-	-	-	-	-	-	-	-	-
Hebrew7	0H	✓	-	-	-	-	-	✓	-	-	-	-	-	-
8859-8 ISO	7H	✓	-	-	-	-	-	✓	-	-	-	-	-	-
Hebrew8	8H	✓	-	-	-	-	-	✓	-	-	-	-	-	-
Pc862Heb	15H	✓	-	-	-	-	-	✓	-	-	-	-	-	-
PC-862, Hebrew	15Q	✓	-	-	-	-	-	✓	-	-	-	-	-	-
Arabic8	8V	-	-	-	-	-	-	-	✓	-	-	-	-	-
HPWARA	9V	-	-	-	-	-	-	-	✓	-	-	-	-	-

Appendix

Symbol Set Name	Attribute	Font Classification												
		1	2	3	4	5	6	7	8	9	10	11	12	13
Pc864Ara	10V	-	-	-	-	-	-	-	✓	-	-	-	-	-
Symbol	19M	-	-	-	✓	-	-	-	-	-	-	-	-	-
Wingdings	579L	-	-	-	-	✓	-	-	-	-	-	-	-	-
ZapfDingbats	14L	-	-	-	-	-	✓	-	-	-	-	-	-	-
OCR A	00	-	-	-	-	-	-	-	-	-	✓	-	-	-
OCR B	10	-	-	-	-	-	-	-	-	-	-	✓	-	-
OCR B Extension	3Q	-	-	-	-	-	-	-	-	-	-	✓	-	-
Code3-9	0Y	-	-	-	-	-	-	-	-	-	-	-	✓	-
EAN/UPC	8Y	-	-	-	-	-	-	-	-	-	-	-	-	✓

Installing the Optional Units

Optional Paper Cassette Unit Code

The following is the code for the optional paper cassette unit.

For worldwide users: Optional Cassette Unit (C12C932871)

For users in India: Optional Cassette Unit (C12C932881)

Installing the Optional Paper Cassette Unit

⚠ Caution:

- ❑ Make sure you turn off the printer, unplug the power cord from the printer, and disconnect any cables before starting installation. Otherwise, the power cord may be damaged resulting in fire or electric shock.
- ❑ When lifting the printer, two or more people should assume the correct positions as shown below. Uninstall paper cassette 2 if it is installed. If you lift the printer holding other positions, the printer may fall or you may trap your fingers when placing the printer.

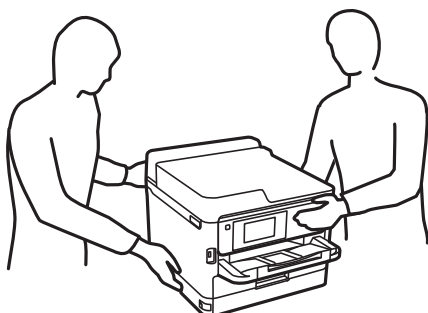

Appendix

1. Turn off the printer by pressing the  button, and then unplug the power cord.
2. Disconnect any connected cables.
3. Uninstall paper cassette 2 if it is installed.

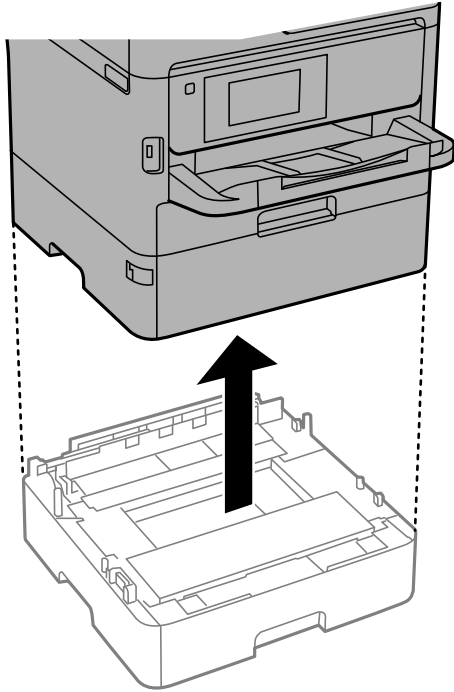

4. Remove the optional paper cassette unit from its box, and then remove any protective materials.
5. Place the optional paper cassette unit where you want to set up the printer.
6. Pull the paper cassette slightly out of paper cassette 2.

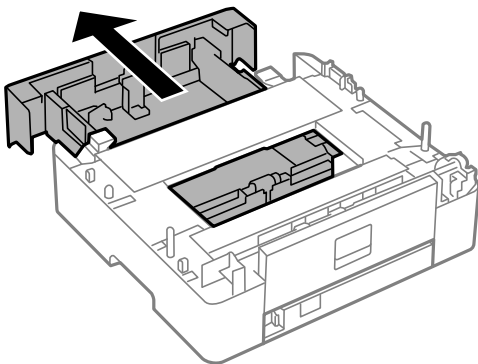

Appendix

7. Remove the part on the back of paper cassette 2.

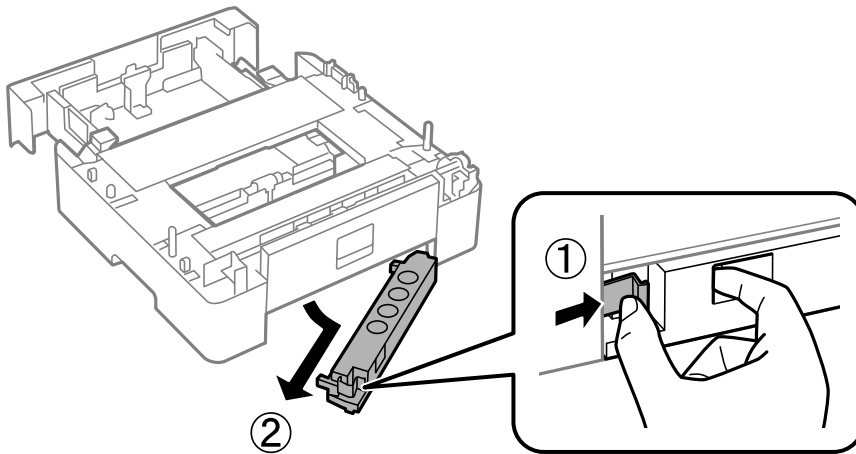

8. Insert the paper cassette all the way into paper cassette 2.
9. Lower paper cassette 2 onto the optional paper cassette unit.

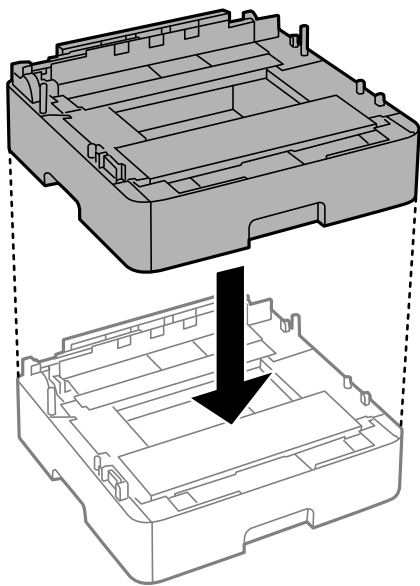

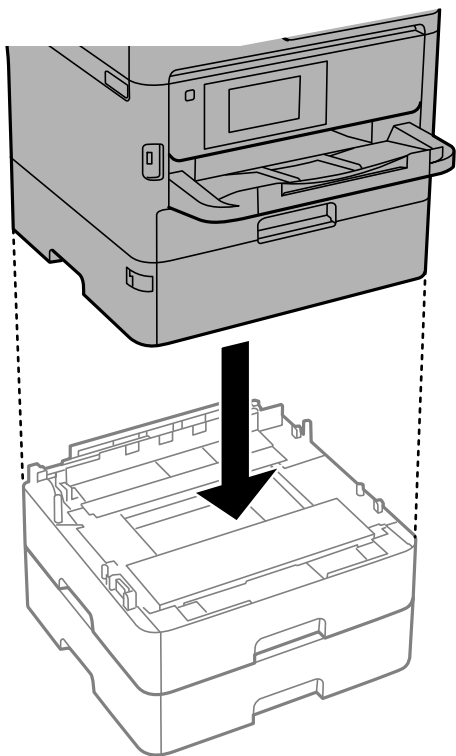

Appendix

10. Lower the printer onto paper cassette 2.

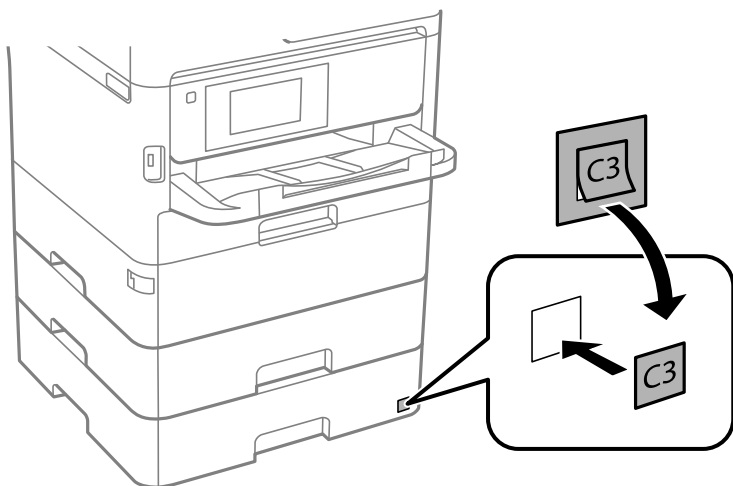

11. Place the sticker indicating the cassette number.



12. Reconnect the power cord and any other cables, and then plug in the printer.
13. Turn on the printer by pressing the  button.
14. Pull out and reinsert the optional paper cassette unit to check that the optional paper cassette unit is displayed on the **Paper Setting** screen.

Note:

When uninstalling the optional paper cassette unit, turn off the printer, unplug the power cord, disconnect any cables, and then perform the installation procedure in reverse.

Appendix

Proceed with the printer driver settings.

Setting the Optional Paper Cassette Unit in the Printer Driver

To use the installed optional paper cassette unit, the printer driver needs to acquire the necessary information.

Setting the Optional Paper Cassette Unit in the Printer Driver - Windows

Note:

Log on to your computer as an administrator.

1. Open the printer list on the computer.
 - Windows 10/Windows Server 2016
Click on the start button, and then select **Windows System > Control Panel > View devices and printers in Hardware and Sound**.
 - Windows 8.1/Windows 8/Windows Server 2012 R2/Windows Server 2012
Select **Desktop > Settings > Control Panel > View devices and printers in Hardware and Sound**.
 - Windows 7/Windows Server 2008 R2
Click the start button, and select **Control Panel > View devices and printers in Hardware and Sound**.
 - Windows Vista/Windows Server 2008
Click the start button, and then select **Control Panel > Printers in Hardware and Sound**.
 - Windows XP/Windows Server 2003 R2/Windows Server 2003
Click the start button, and select **Control Panel > Printers and Other Hardware > Printers and Faxes**.
2. Right-click on your printer, or press and hold it, select **Printer properties** or **Property**, and then click the **Optional Settings** tab.
3. Select **Acquire from Printer**, and then click **Get**.
Optional Paper Sources information is displayed in **Current Printer Information**.
4. Click **OK**.

Setting the Optional Paper Cassette Unit in the Printer Driver - Mac OS

1. Select **System Preferences** from the  menu > **Printers & Scanners** (or **Print & Scan, Print & Fax**), and then select the printer. Click **Options & Supplies > Options** (or **Driver**).
2. Set **Lower Cassette** according to the number of paper cassettes.
3. Click **OK**.

Regulatory Information

Standards and Approvals

Standards and Approvals for U.S. Model

Safety	UL60950-1 CAN/CSA-C22.2 No.60950-1
EMC	FCC Part 15 Subpart B Class B CAN/CSA-CEI/IEC CISPR 22 Class B

This equipment contains the following wireless module.

Manufacturer: Seiko Epson Corporation

Type: J26H006

This product conforms to Part 15 of the FCC Rules and RSS-210 of the IC Rules. Epson cannot accept responsibility for any failure to satisfy the protection requirements resulting from a non-recommended modification of the product. Operation is subject to the following two conditions: (1) this device may not cause harmful interference, and (2) this device must accept any interference received, including interference that may cause undesired operation of the device.

To prevent radio interference to the licensed service, this device is intended to be operated indoors and away from windows to provide maximum shielding. Equipment (or its transmit antenna) that is installed outdoors is subject to licensing.

This equipment complies with FCC/IC radiation exposure limits set forth for an uncontrolled environment and meets the FCC radio frequency (RF) Exposure Guidelines in Supplement C to OET65 and RSS-102 of the IC radio frequency (RF) Exposure rules. This equipment should be installed and operated so that the radiator is kept at least 7.9 inches (20 cm) or more away from a person's body (excluding extremities: hands, wrists, feet and ankles).

Standards and Approvals for European Model

For European users

Hereby, Seiko Epson Corporation declares that the following radio equipment model is in compliance with Directive 2014/53/EU. The full text of the EU declaration of conformity is available at the following website.

<http://www.epson.eu/conformity>

C644A

For use only in Ireland, UK, Austria, Germany, Liechtenstein, Switzerland, France, Belgium, Luxemburg, Netherlands, Italy, Portugal, Spain, Denmark, Finland, Norway, Sweden, Iceland, Croatia, Cyprus, Greece, Slovenia, Malta, Bulgaria, Czech, Estonia, Hungary, Latvia, Lithuania, Poland, Romania, and Slovakia.

Epson cannot accept responsibility for any failure to satisfy the protection requirements resulting from a non-recommended modification of the products.



Appendix

Standards and Approvals for Australian Model

EMC	AS/NZS CISPR32 Class B
-----	------------------------

Epson hereby declares that the following equipment Models are in compliance with the essential requirements and other relevant provisions of AS/NZS4268:

C644A

Epson cannot accept responsibility for any failure to satisfy the protection requirements resulting from a non-recommended modification of the products.

Standards and Approvals for New Zealand Model

General Warning

The grant of a Telepermit for any item of terminal equipment indicates only that Telecom has accepted that the item complies with minimum conditions for connection to its network. It indicates no endorsement of the product by Telecom, nor does it provide any sort of warranty. Above all, it provides no assurance that any item will work correctly in all respects with another item of Telepermitted equipment of a different make or model, nor does it imply that any product is compatible with all of Telecom's network services.

Telepermitted equipment only may be connected to the EXT telephone port. This port is not specifically designed for 3-wire-connected equipment. 3-wire-connected equipment might not respond to incoming ringing when attached to this port.

Important Notice

Under power failure conditions, this telephone may not operate. Please ensure that a separate telephone, not dependent on local power, is available for emergency use.

This equipment is not capable, under all operating conditions, of correct operation at the higher speeds for which it is designed. Telecom will accept no responsibility should difficulties arise in such circumstances.

This equipment shall not be set up to make automatic calls to the Telecom '111' Emergency Service.

German Blue Angel

See the following website to check whether or not this printer meets the standards for the German Blue Angel.

<http://www.epson.de/blauerengel>

Restrictions on Copying

Observe the following restrictions to ensure the responsible and legal use of the printer.

Copying of the following items is prohibited by law:

- Bank bills, coins, government-issued marketable securities, government bond securities, and municipal securities
- Unused postage stamps, pre-stamped postcards, and other official postal items bearing valid postage
- Government-issued revenue stamps, and securities issued according to legal procedure

Exercise caution when copying the following items:

Appendix

- Private marketable securities (stock certificates, negotiable notes, checks, etc.), monthly passes, concession tickets, etc.
- Passports, driver's licenses, warrants of fitness, road passes, food stamps, tickets, etc.

Note:

Copying these items may also be prohibited by law.

Responsible use of copyrighted materials:

Printers can be misused by improperly copying copyrighted materials. Unless acting on the advice of a knowledgeable attorney, be responsible and respectful by obtaining the permission of the copyright holder before copying published material.

Transporting and Storing the Printer

When you need to store the printer or transport it when moving or for repairs, follow the steps below to pack the printer.

⚠ Caution:

- When carrying the printer, lift it using a stable position. Lifting the printer using an unstable position may result in injury.
- Because this printer is heavy, it should always be carried by two or more people when unpacking and transporting.
- When lifting the printer, two or more people should assume the correct positions as shown below. Uninstall paper cassette 2 if it is installed. If you lift the printer holding other positions, the printer may fall or you may trap your fingers when placing the printer.

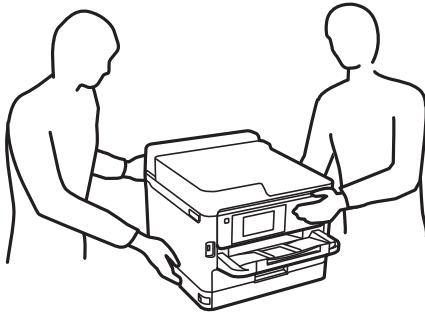

- When carrying the printer, do not tilt it more than 10 degrees; otherwise the printer may fall.
- Be careful not to trap your hand or fingers when opening or closing the scanner unit. Otherwise you may be injured.

⚠ Important:

- When storing or transporting the printer, avoid tilting it, placing it vertically, or turning it upside down; otherwise ink may leak.
- Leave the ink supply units installed. Removing the ink supply units can dry out the print head and may prevent the printer from printing.

1. Turn off the printer by pressing the  button.

Appendix

2. Make sure the power light turns off, and then unplug the power cord.



Important:

Unplug the power cord when the power light is off. Otherwise, the print head does not return to the home position causing the ink to dry, and printing may become impossible.

3. Disconnect all cables such as the power cord and USB cable.
4. If the printer supports external storage devices, make sure they are not connected.
5. Remove all of the paper from the printer.
6. Make sure there are no originals on the printer.
7. Open the scanner unit with the document cover closed. Secure the print head to the case with tape.



Appendix

8. Close the scanner unit.

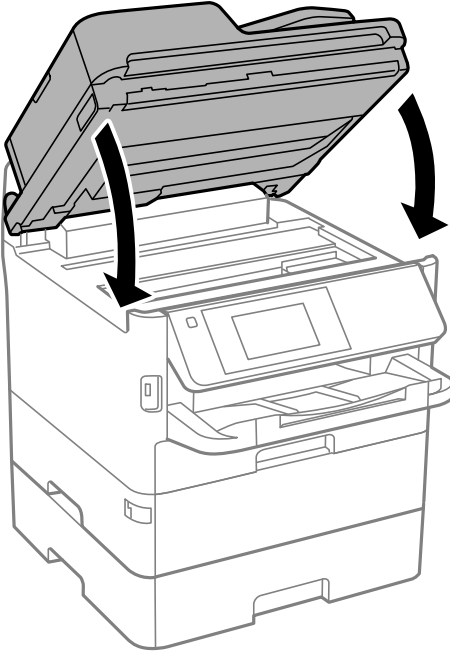

9. Uninstall paper cassette 2 and the optional paper cassette unit if it is installed.

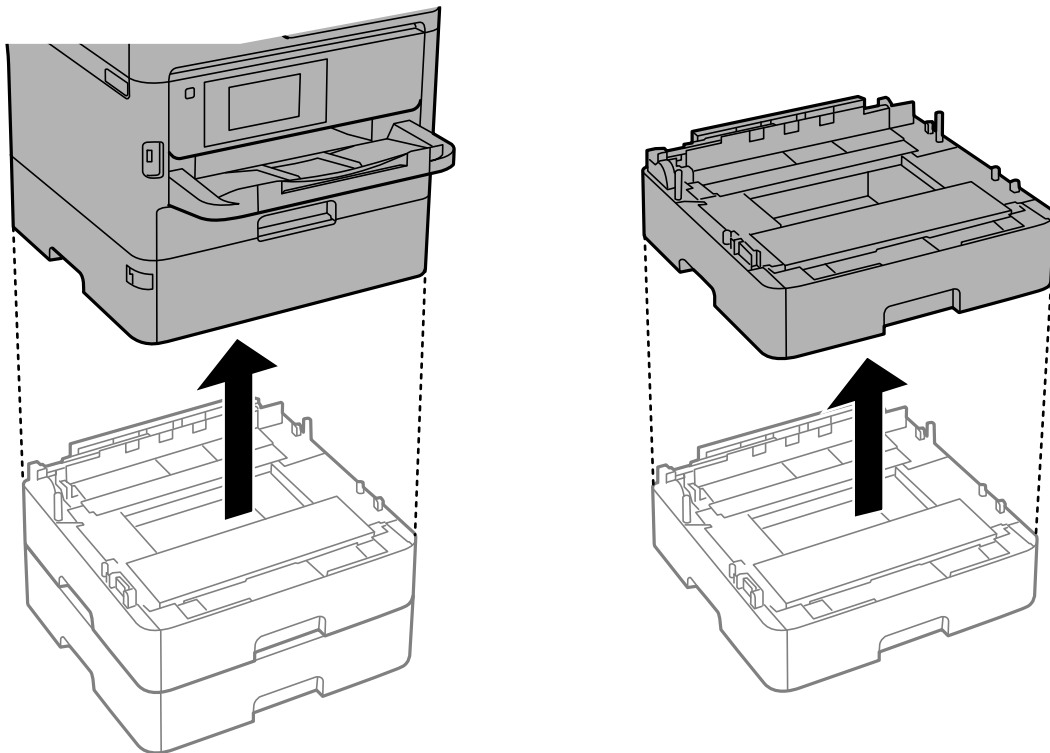

Appendix

10. Prepare to pack the printer as shown below.

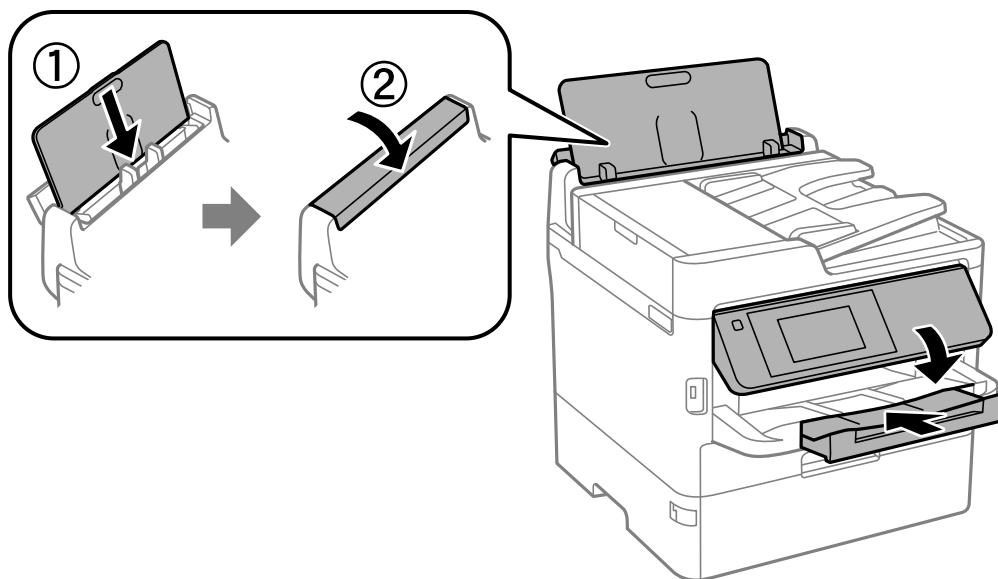

11. Remove the output tray from the printer.

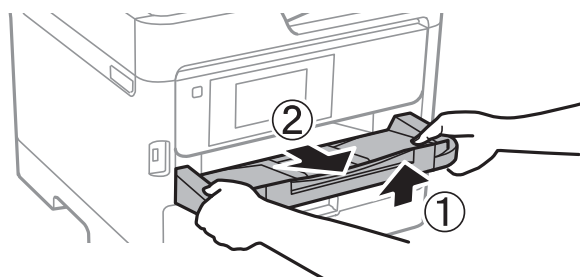

12. Pack the printer in its box, using the protective materials.

When you use the printer again, make sure you remove the tape securing the print head. If print quality has declined the next time you print, clean and align the print head.

Related Information

- ➔ [“Part Names and Functions” on page 16](#)
- ➔ [“Checking and Cleaning the Print Head” on page 231](#)
- ➔ [“Adjusting the Print Quality” on page 267](#)

Copyright

No part of this publication may be reproduced, stored in a retrieval system, or transmitted in any form or by any means, electronic, mechanical, photocopying, recording, or otherwise, without the prior written permission of Seiko Epson Corporation. No patent liability is assumed with respect to the use of the information contained herein. Neither is any liability assumed for damages resulting from the use of the information herein. The information contained herein is designed only for use with this Epson product. Epson is not responsible for any use of this information as applied to other products.

Appendix

Neither Seiko Epson Corporation nor its affiliates shall be liable to the purchaser of this product or third parties for damages, losses, costs, or expenses incurred by the purchaser or third parties as a result of accident, misuse, or abuse of this product or unauthorized modifications, repairs, or alterations to this product, or (excluding the U.S.) failure to strictly comply with Seiko Epson Corporation's operating and maintenance instructions.

Seiko Epson Corporation and its affiliates shall not be liable for any damages or problems arising from the use of any options or any consumable products other than those designated as Original Epson Products or Epson Approved Products by Seiko Epson Corporation.

Seiko Epson Corporation shall not be held liable for any damage resulting from electromagnetic interference that occurs from the use of any interface cables other than those designated as Epson Approved Products by Seiko Epson Corporation.

© 2018 Seiko Epson Corporation

The contents of this manual and the specifications of this product are subject to change without notice.

Trademarks

❑ EPSON® is a registered trademark, and EPSON EXCEED YOUR VISION or EXCEED YOUR VISION is a trademark of Seiko Epson Corporation.

❑ Epson Scan 2 software is based in part on the work of the Independent JPEG Group.

❑ libtiff

Copyright © 1988-1997 Sam Leffler

Copyright © 1991-1997 Silicon Graphics, Inc.

Permission to use, copy, modify, distribute, and sell this software and its documentation for any purpose is hereby granted without fee, provided that (i) the above copyright notices and this permission notice appear in all copies of the software and related documentation, and (ii) the names of Sam Leffler and Silicon Graphics may not be used in any advertising or publicity relating to the software without the specific, prior written permission of Sam Leffler and Silicon Graphics.

THE SOFTWARE IS PROVIDED "AS-IS" AND WITHOUT WARRANTY OF ANY KIND, EXPRESS, IMPLIED OR OTHERWISE, INCLUDING WITHOUT LIMITATION, ANY WARRANTY OF MERCHANTABILITY OR FITNESS FOR A PARTICULAR PURPOSE.

IN NO EVENT SHALL SAM LEFFLER OR SILICON GRAPHICS BE LIABLE FOR ANY SPECIAL, INCIDENTAL, INDIRECT OR CONSEQUENTIAL DAMAGES OF ANY KIND, OR ANY DAMAGES WHATSOEVER RESULTING FROM LOSS OF USE, DATA OR PROFITS, WHETHER OR NOT ADVISED OF THE POSSIBILITY OF DAMAGE, AND ON ANY THEORY OF LIABILITY, ARISING OUT OF OR IN CONNECTION WITH THE USE OR PERFORMANCE OF THIS SOFTWARE.

❑ QR Code is a registered trademark of DENSO WAVE INCORPORATED in Japan and other countries.

❑ Intel® is a registered trademark of Intel Corporation.

❑ Microsoft®, Windows®, Windows Server®, and Windows Vista® are registered trademarks of Microsoft Corporation.

❑ Apple, Macintosh, macOS, OS X, Bonjour, ColorSync, Safari, AirPrint, the AirPrint Logo, iPad, iPhone, iPod touch, and iTunes are trademarks of Apple Inc., registered in the U.S. and other countries.

❑ Google Cloud Print, Chrome, Chrome OS, Google Play and Android are trademarks of Google Inc.

❑ Adobe, the Adobe logo, Acrobat, Photoshop, PostScript®3™, and Reader are either registered trademarks or trademarks of Adobe Systems Incorporated in the United States and/or other countries.

Appendix

- ❑ Albertus, Arial, Coronet, Gill Sans, Joanna and Times New Roman are trademarks of The Monotype Corporation registered in the United States Patent and Trademark Office and may be registered in certain jurisdictions.
- ❑ ITC Avant Garde Gothic, ITC Bookman, Lubalin Graph, Mona Lisa, ITC Symbol, Zapf Chancery and Zapf Dingbats are trademarks of International Typeface Corporation registered in the U.S. Patent and Trademark Office and may be registered in certain other jurisdictions.
- ❑ Clarendon, Eurostile and New Century Schoolbook are trademarks of Linotype GmbH registered in the U.S. Patent and Trademark Office and may be registered in certain other jurisdictions.
- ❑ Wingdings is a registered trademark of Microsoft Corporation in the United States and other countries.
- ❑ CG Omega, CG Times, Garamond Antiqua, Garamond Halbfett, Garamond Kursiv, Garamond Halbfett Kursiv are trademarks of Monotype Imaging, Inc. and may be registered in certain jurisdictions.
- ❑ Antique Olive is a trademark of M. Olive.
- ❑ Marigold and Oxford are trademarks of AlphaOmega Typography.
- ❑ Helvetica, Optima, Palatino, Times and Univers are trademarks of Linotype Corp. registered in the U.S. Patent and Trademark Office and may be registered in certain other jurisdictions in the name of Linotype Corp. or its licensee Linotype GmbH.
- ❑ PCL is the registered trademark of Hewlett-Packard Company.
- ❑ Arcfour

This code illustrates a sample implementation of the Arcfour algorithm.

Copyright © April 29, 1997 Kalle Kaukonen. All Rights Reserved.

Redistribution and use in source and binary forms, with or without modification, are permitted provided that this copyright notice and disclaimer are retained.

THIS SOFTWARE IS PROVIDED BY KALLE KAUKONEN AND CONTRIBUTORS "AS IS" AND ANY EXPRESS OR IMPLIED WARRANTIES, INCLUDING, BUT NOT LIMITED TO, THE IMPLIED WARRANTIES OF MERCHANTABILITY AND FITNESS FOR A PARTICULAR PURPOSE ARE DISCLAIMED. IN NO EVENT SHALL KALLE KAUKONEN OR CONTRIBUTORS BE LIABLE FOR ANY DIRECT, INDIRECT, INCIDENTAL, SPECIAL, EXEMPLARY, OR CONSEQUENTIAL DAMAGES (INCLUDING, BUT NOT LIMITED TO, PROCUREMENT OF SUBSTITUTE GOODS OR SERVICES; LOSS OF USE, DATA, OR PROFITS; OR BUSINESS INTERRUPTION) HOWEVER CAUSED AND ON ANY THEORY OF LIABILITY, WHETHER IN CONTRACT, STRICT LIABILITY, OR TORT (INCLUDING NEGLIGENCE OR OTHERWISE) ARISING IN ANY WAY OUT OF THE USE OF THIS SOFTWARE, EVEN IF ADVISED OF THE POSSIBILITY OF SUCH DAMAGE.

- ❑ microSDHC Logo is a trademark of SD-3C, LLC.

Note: microSDHC is built into the product and cannot be removed.



- ❑ General Notice: Other product names used herein are for identification purposes only and may be trademarks of their respective owners. Epson disclaims any and all rights in those marks.

Where to Get Help

Technical Support Web Site

If you need further help, visit the Epson support website shown below. Select your country or region and go to the support section of your local Epson website. The latest drivers, FAQs, manuals, or other downloadables are also available from the site.

<http://support.epson.net/>

<http://www.epson.eu/Support> (Europe)

If your Epson product is not operating properly and you cannot solve the problem, contact Epson support services for assistance.

Contacting Epson Support

Before Contacting Epson

If your Epson product is not operating properly and you cannot solve the problem using the troubleshooting information in your product manuals, contact Epson support services for assistance. If Epson support for your area is not listed below, contact the dealer where you purchased your product.

Epson support will be able to help you much more quickly if you give them the following information:

- Product serial number
(The serial number label is usually on the back of the product.)
- Product model
- Product software version
(Click **About**, **Version Info**, or a similar button in the product software.)
- Brand and model of your computer
- Your computer operating system name and version
- Names and versions of the software applications you normally use with your product

Note:

Depending on the product, the dial list data for fax and/or network settings may be stored in the product's memory. Due to breakdown or repair of a product, data and/or settings may be lost. Epson shall not be responsible for the loss of any data, for backing up or recovering data and/or settings even during a warranty period. We recommend that you make your own backup data or take notes.

Help for Users in Europe

Check your Pan-European Warranty Document for information on how to contact Epson support.

Help for Users in Taiwan

Contacts for information, support, and services are:

Appendix

World Wide Web

<http://www.epson.com.tw>

Information on product specifications, drivers for download, and products enquiry are available.

Epson HelpDesk

Phone: +886-2-80242008

Our HelpDesk team can help you with the following over the phone:

- Sales enquiries and product information
- Product usage questions or problems
- Enquiries on repair service and warranty

Repair service center:

<http://www.tekcare.com.tw/branchMap.page>

TekCare corporation is an authorized service center for Epson Taiwan Technology & Trading Ltd.

Help for Users in Australia

Epson Australia wishes to provide you with a high level of customer service. In addition to your product manuals, we provide the following sources for obtaining information:

Internet URL

<http://www.epson.com.au>

Access the Epson Australia World Wide Web pages. Worth taking your modem here for the occasional surf! The site provides a download area for drivers, Epson contact points, new product information and technical support (e-mail).

Epson Helpdesk

Phone: 1300-361-054

Epson Helpdesk is provided as a final backup to make sure our clients have access to advice. Operators on the Helpdesk can aid you in installing, configuring and operating your Epson product. Our Pre-sales Helpdesk staff can provide literature on new Epson products and advise where the nearest dealer or service agent is located. Many types of queries are answered here.

We encourage you to have all the relevant information on hand when you ring. The more information you prepare, the faster we can help solve the problem. This information includes your Epson product manuals, type of computer, operating system, application programs, and any information you feel is required.

Transportation of Product

Epson recommends retaining product packaging for future transportation.

Help for Users in New Zealand

Epson New Zealand wishes to provide you with a high level of customer service. In addition to your product documentation, we provide the following sources for obtaining information:

Appendix

Internet URL

<http://www.epson.co.nz>

Access the Epson New Zealand World Wide Web pages. Worth taking your modem here for the occasional surf! The site provides a download area for drivers, Epson contact points, new product information and technical support (e-mail).

Epson Helpdesk

Phone: 0800 237 766

Epson Helpdesk is provided as a final backup to make sure our clients have access to advice. Operators on the Helpdesk can aid you in installing, configuring and operating your Epson product. Our Pre-sales Helpdesk staff can provide literature on new Epson products and advise where the nearest dealer or service agent is located. Many types of queries are answered here.

We encourage you to have all the relevant information on hand when you ring. The more information you prepare, the faster we can help solve the problem. This information includes your Epson product documentation, type of computer, operating system, application programs, and any information you feel is required.

Transportation of Product

Epson recommends retaining product packaging for future transportation.

Help for Users in Singapore

Sources of information, support, and services available from Epson Singapore are:

World Wide Web

<http://www.epson.com.sg>

Information on product specifications, drivers for download, Frequently Asked Questions (FAQ), Sales Enquiries, and Technical Support via e-mail are available.

Epson HelpDesk

Toll Free: 800-120-5564

Our HelpDesk team can help you with the following over the phone:

- Sales enquiries and product information
- Product usage questions or problem troubleshooting
- Enquiries on repair service and warranty

Help for Users in Thailand

Contacts for information, support, and services are:

World Wide Web

<http://www.epson.co.th>

Information on product specifications, drivers for download, Frequently Asked Questions (FAQ), and e-mail are available.

Appendix

Epson Call Centre

Phone: 66-2685-9899

Email: support@eth.epson.co.th

Our Call Centre team can help you with the following over the phone:

- Sales enquiries and product information
- Product usage questions or problems
- Enquiries on repair service and warranty

Help for Users in Vietnam

Contacts for information, support, and services are:

Epson Service Center

65 Truong Dinh Street, District 1, Hochiminh City, Vietnam.

Phone(Ho Chi Minh City): 84-8-3823-9239, 84-8-3825-6234

29 Tue Tinh, Quan Hai Ba Trung, Hanoi City, Vietnam

Phone(Hanoi City): 84-4-3978-4785, 84-4-3978-4775

Help for Users in Indonesia

Contacts for information, support, and services are:

World Wide Web

<http://www.epson.co.id>

- Information on product specifications, drivers for download
- Frequently Asked Questions (FAQ), Sales Enquiries, questions through e-mail

Epson Hotline

Phone: +62-1500-766

Fax: +62-21-808-66-799

Our Hotline team can help you with the following over the phone or fax:

- Sales enquiries and product information
- Technical support

Epson Service Center

Province	Company Name	Address	Phone E-mail
DKI JAKARTA	ESS JAKARTA MANGGADUA	Ruko Mall Mangga Dua No. 48 Jl. Arteri Mangga Dua, Jakarta Utara - DKI JAKARTA	(+6221) 62301104 jkt-admin@epson-indonesia.co.id

Appendix

Province	Company Name	Address	Phone E-mail
NORTH SUMATERA	ESC MEDAN	Jl. Bambu 2 Komplek Graha Niaga Nomor A-4, Medan - North Sumatera	(+6261) 42066090 / 42066091 mdn-adm@epson-indonesia.co.id
WEST JAWA	ESC BANDUNG	Jl. Cihampelas No. 48 A Bandung Jawa Barat 40116	(+6222) 4207033 bdg-admin@epson-indonesia.co.id
DI YOGYAKARTA	ESC YOGYAKARTA	YAP Square, Block A No. 6 Jl. C Simanjutak Yogyakarta - DIY	(+62274) 581065 ygy-admin@epson-indonesia.co.id
EAST JAWA	ESC SURABAYA	Hitech Mall Lt. 2 Block A No. 24 Jl. Kusuma Bangsa No. 116 - 118 Surabaya - JATIM	(+6231) 5355035 sby-admin@epson-indonesia.co.id
SOUTH SULAWESI	ESC MAKASSAR	Jl. Cendrawasih NO. 3A, kunjung mae, mariso, MAKASSAR - SULSEL 90125	(+62411) 8911071 mksr-admin@epson-indonesia.co.id
WEST KALIMANTAN	ESC PONTIANAK	Komp. A yani Sentra Bisnis G33, Jl. Ahmad Yani - Pontianak Kalimantan Barat	(+62561) 735507 / 767049 pontianak-admin@epson-indonesia.co.id
RIAU	ESC PEKANBARU	Jl. Tuanku Tambusai No.459A Pekanbaru Riau	(+62761) 8524695 pkb-admin@epson-indonesia.co.id
DKI JAKARTA	ESS JAKARTA SUDIRMAN	Wisma Keiai Lt. 1 Jl. Jenderal Sudirman Kav. 3 Jakarta Pusat - DKI JAKARTA 10220	(+6221) 5724335 ess@epson-indonesia.co.id
EAST JAWA	ESS SURABAYA	Ruko Surya Inti Jl. Jawa No 2-4 Kav. 29 Surabaya - Jawa Timur	(+6231) 5014949 esssby@epson-indonesia.co.id
BANTEN	ESS SERPONG	Ruko Mall WTC Matahari No. 953, Serpong-Banten	(+6221) 53167051 / 53167052 esstag@epson-indonesia.co.id
CENTRAL JAWA	ESS SEMARANG	Komplek Ruko Metro Plaza Block C20 Jl. MT Haryono No 970 Semarang - JAWA TENGAH	(+6224) 8313807 / 8417935 esssmg@epson-indonesia.co.id
EAST KALIMANTAN	ESC SAMARINDA	Jl. KH. Wahid Hasyim (M. Yamin) Kelurahan Sempaja Selatan Kecamatan Samarinda UTARA - SAMARINDA - KALTIM	(+62541) 7272904 escsmd@epson-indonesia.co.id
SOUTH SUMATERA	ESC PALEMBANG	Jl. H.M Rasyid Nawawi No. 249 Kelurahan 9 Ilir Palembang Sumatera Selatan	(+62711) 311330 escplg@epson-indonesia.co.id
EAST JAVA	ESC JEMBER	JL. Panglima Besar Sudirman Ruko no.1D Jember-Jawa Timur (Depan Balai Penelitian & Pengolahan Kakao)	(+62331) 488373 / 486468 jmr-admin@epson-indonesia.co.id
NORTH SULAWESI	ESC MANADO	Tekno Megamall Lt LG 11 TK 21, Kawasan Megamas Boulevard, Jl Piere Tendean, Manado - SULUT 95111	(+62431) 8890996 MND-ADMIN@EPSON-INDONESIA.CO.ID

Appendix

For other cities not listed here, call the Hot Line: 08071137766.

Help for Users in Malaysia

Contacts for information, support, and services are:

World Wide Web

<http://www.epson.com.my>

- Information on product specifications, drivers for download
- Frequently Asked Questions (FAQ), Sales Enquiries, questions through e-mail

Epson Call Centre

Phone: +60 1800-8-17349

- Sales enquiries and product information
- Product usage questions or problems
- Enquiries on repair services and warranty

Head Office

Phone: 603-56288288

Fax: 603-5628 8388/603-5621 2088

Help for Users in India

Contacts for information, support, and services are:

World Wide Web

<http://www.epson.co.in>

Information on product specifications, drivers for download, and products enquiry are available.

Helpline

- Service, product information, and ordering consumables (BSNL Lines)
Toll-free number: 18004250011
Accessible 9am to 6pm, Monday through Saturday (Except public holidays)
- Service (CDMA & Mobile Users)
Toll-free number: 186030001600
Accessible 9am to 6pm, Monday through Saturday (Except public holidays)

Help for Users in the Philippines

To obtain technical support as well as other after sales services, users are welcome to contact the Epson Philippines Corporation at the telephone, fax numbers and e-mail address below:

Appendix

World Wide Web

<http://www.epson.com.ph>

Information on product specifications, drivers for download, Frequently Asked Questions (FAQ), and E-mail Enquiries are available.

Epson Philippines Customer Care

Toll Free: (PLDT) 1-800-1069-37766

Toll Free: (Digital) 1-800-3-0037766

Metro Manila: (+632)441-9030

Web Site: <https://www.epson.com.ph/contact>

E-mail: customercare@epc.epson.com.ph

Accessible 9am to 6pm, Monday through Saturday (Except public holidays)

Our Customer Care team can help you with the following over the phone:

- Sales enquiries and product information
- Product usage questions or problems
- Enquiries on repair service and warranty

Epson Philippines Corporation

Trunk Line: +632-706-2609

Fax: +632-706-2663