



RS100-E10-PI2

1U Rackmount Server User Guide



E14282
First Edition
August 2018

Copyright © 2018 ASUSTeK COMPUTER INC. All Rights Reserved.

No part of this manual, including the products and software described in it, may be reproduced, transmitted, transcribed, stored in a retrieval system, or translated into any language in any form or by any means, except documentation kept by the purchaser for backup purposes, without the express written permission of ASUSTeK COMPUTER INC. ("ASUS").

ASUS provides this manual "as is" without warranty of any kind, either express or implied, including but not limited to the implied warranties or conditions of merchantability or fitness for a particular purpose. In no event shall ASUS, its directors, officers, employees, or agents be liable for any indirect, special, incidental, or consequential damages (including damages for loss of profits, loss of business, loss of use or data, interruption of business and the like), even if ASUS has been advised of the possibility of such damages arising from any defect or error in this manual or product.

Specifications and information contained in this manual are furnished for informational use only, and are subject to change at any time without notice, and should not be construed as a commitment by ASUS. ASUS assumes no responsibility or liability for any errors or inaccuracies that may appear in this manual, including the products and software described in it.

Product warranty or service will not be extended if: (1) the product is repaired, modified or altered, unless such repair, modification or alteration is authorized in writing by ASUS; or (2) the serial number of the product is defaced or missing.

Products and corporate names appearing in this manual may or may not be registered trademarks or copyrights of their respective companies, and are used only for identification or explanation and to the owners' benefit, without intent to infringe.

Contents

Safety information.....	vii
About this guide.....	ix

Chapter 1: Product Introduction

1.1	System package contents.....	1-2
1.2	Serial number label.....	1-2
1.3	System specifications	1-3
1.4	Front panel features.....	1-5
1.5	Rear panel features.....	1-5
1.6	Internal features	1-6
1.7	LED information	1-7
1.7.1	Front panel LEDs	1-7
1.7.2	Rear panel LEDs.....	1-8
1.7.3	LAN (RJ-45) LEDs	1-8

Chapter 2: Hardware Information

2.1	Chassis cover.....	2-2
2.1.1	Removing the chassis cover	2-2
2.1.2	Reinstalling the chassis cover.....	2-3
2.2	Central Processing Unit (CPU)	2-5
2.2.1	Installing the CPU	2-5
2.2.2	Installing the CPU heatsink.....	2-8
2.3	System memory	2-10
2.3.1	Overview	2-10
2.3.2	Memory configurations.....	2-10
2.3.3	Installing a DIMM on a single clip DIMM socket.....	2-11
2.4	Hard disk drives	2-13
2.4.1	Installing a hard disk drive to the HDD bay 1	2-13
2.4.2	Installing 2.5-inch SSDs on HDD bay 1 (Optional).....	2-17
2.4.3	Installing a 3.5-inch Serial ATA HDD to HDD bay 2.....	2-20
2.4.3	Installing 2.5-inch SSDs on HDD bay 2 (Optional).....	2-23
2.5	Expansion card	2-26
2.5.1	Installing an expansion card.....	2-26
2.5.2	Configuring an expansion card	2-28
2.5.3	Installing M.2 (NGFF) cards.....	2-29

Contents

2.6	Cable connections	2-30
2.7	Removable/optional components	2-31
2.7.1	System fans	2-31
2.7.2	Optical disk drive (optional).....	2-32
2.7.3	Installing ASMB9 series management card (optional)	2-33

Chapter 3: Installation Options

3.1	Rackmount rail kit items	3-2
3.2	Attaching the rails to the rack	3-2

Chapter 4: Motherboard Information

4.1	Before you proceed	4-2
4.2	Motherboard overview	4-3
4.2.1	Placement direction.....	4-3
4.2.2	Screw holes.....	4-3
4.2.3	Motherboard layout	4-4
4.2.4	Layout contents.....	4-5
4.3	Onboard LEDs	4-7
4.4	Jumpers	4-10
4.5	Connectors	4-15
4.5.1	Rear panel connectors.....	4-15
4.5.2	Q-Code table.....	4-17
4.5.3	Internal connectors.....	4-19

Chapter 5: BIOS Setup

5.1	Managing and updating your BIOS	5-2
5.1.1	ASUS CrashFree BIOS 3 utility.....	5-2
5.1.2	ASUS EzFlash Utility.....	5-3
5.1.3	BUPDATER utility	5-4
5.2	BIOS setup program	5-6
5.2.1	BIOS menu screen.....	5-7
5.2.2	Menu bar	5-7
5.2.3	Menu items.....	5-8
5.2.4	Submenu items	5-8
5.2.5	Navigation keys.....	5-8
5.2.6	General help.....	5-8
5.2.7	Configuration fields	5-8
5.2.8	Pop-up window.....	5-8
5.2.9	Scroll bar	5-8

Contents

5.3	Main menu	5-9
5.4	Advanced menu	5-10
5.4.1	CPU Configuration	5-11
5.4.2	Power & Performance	5-13
5.4.3	Server ME Configuration	5-15
5.4.4	Trusted Computing.....	5-15
5.4.5	APM Configuration	5-16
5.4.6	Runtime Error Logging Settings	5-16
5.4.7	Onboard LAN Configuration	5-17
5.4.8	Serial Port Console Redirection	5-18
5.4.9	Intel TXT Information.....	5-20
5.4.10	PCI Subsystem Settings	5-21
5.4.11	USB Configuration	5-22
5.4.12	Network Stack Configuration.....	5-23
5.4.13	CSM Configuration	5-24
5.4.14	NVMe Configuration.....	5-25
5.4.15	WHEA Configuration	5-25
5.4.16	Tls Auth Configuration.....	5-26
5.4.17	iSCSI Configuration	5-26
5.5	Chipset menu	5-27
5.5.1	System Agent (SA) Configuration	5-27
5.5.2	PCH-IO Configuration	5-29
5.6	Security menu	5-31
5.7	Boot menu	5-34
5.8	Monitor menu	5-36
5.9	Tool menu.....	5-37
5.10	Event Logs menu	5-37
5.10.1	Change Smbios Event Log Settings	5-37
5.10.2	View Smbios Event Log	5-38
5.11	Server Mgmt menu.....	5-39
5.11.1	System Event Log.....	5-40
5.11.2	Bmc self test log.....	5-41
5.11.3	BMC network configuration.....	5-42
5.11.4	View System Event Log	5-43
5.11.5	BMC User Settings.....	5-43
5.12	Save & Exit menu.....	5-44

Contents

Chapter 6: RAID Configuration

6.1	Setting up RAID	6-2
6.1.1	RAID definitions	6-2
6.1.2	Installing hard disk drives.....	6-3
6.1.3	Setting the RAID mode in BIOS.....	6-3
6.1.4	RAID configuration utilities.....	6-3
6.2	Intel® Rapid Storage Technology enterprise SATA Option ROM Utility	6-4
6.2.1	Creating a RAID set.....	6-5
6.2.2	Deleting a RAID set.....	6-7
6.2.3	Resetting disks to Non-RAID	6-8
6.2.4	Exiting the Intel® Rapid Storage Technology enterprise SATA Option ROM utility.....	6-9
6.2.5	Rebuilding the RAID.....	6-9
6.2.6	Setting the Boot array in the BIOS Setup Utility.....	6-11
6.3	Intel® Rapid Storage Technology enterprise (Windows)	6-12
6.3.1	Creating a RAID set.....	6-13
6.3.2	Changing a Volume Type.....	6-15
6.3.3	Deleting a volume	6-16
6.3.4	Preferences.....	6-17

Chapter 7: Driver Installation

7.1	RAID driver installation	7-2
7.1.1	Creating a USB flash drive with RAID drive.....	7-2
7.1.2	Installing the RAID controller driver.....	7-2
7.2	Management applications and utilities installation	7-5
7.3	Running the Support DVD	7-5
7.4	Installing the system drivers	7-6

Appendix

P11C-M/4L block diagram	A-2
Notices	A-3
ASUS contact information	A-5

Safety information

Electrical Safety

- Before installing or removing signal cables, ensure that the power cables for the system unit and all attached devices are unplugged.
- To prevent electrical shock hazard, disconnect the power cable from the electrical outlet before relocating the system.
- When adding or removing any additional devices to or from the system, ensure that the power cables for the devices are unplugged before the signal cables are connected. If possible, disconnect all power cables from the existing system before you add a device.
- If the power supply is broken, do not try to fix it by yourself. Contact a qualified service technician or your dealer.

Operation Safety

- Any mechanical operation on this server must be conducted by certified or experienced engineers.
- Before operating the server, carefully read all the manuals included with the server package.
- Before using the server, ensure all cables are correctly connected and the power cables are not damaged. If any damage is detected, contact your dealer as soon as possible.
- To avoid short circuits, keep paper clips, screws, and staples away from connectors, slots, sockets and circuitry.
- Avoid dust, humidity, and temperature extremes. Place the server on a stable surface.



This product is equipped with a three-wire power cable and plug for the user's safety. Use the power cable with a properly grounded electrical outlet to avoid electrical shock.

Lithium-Ion Battery Warning

CAUTION! Danger of explosion if battery is incorrectly replaced. Replace only with the same or equivalent type recommended by the manufacturer. Dispose of used batteries according to the manufacturer's instructions.

Heavy System

CAUTION! This server system is heavy. Ask for assistance when moving or carrying the system.

Optical Drive Safety Information

Laser Safety Information



To prevent exposure to the optical drive's laser, do not attempt to disassemble or repair the optical drive by yourself. For your safety, contact a professional technician for assistance.

About this guide

Audience

This user guide is intended for system integrators, and experienced users with at least basic knowledge of configuring a server.

Contents

This guide contains the following parts:

1. Chapter 1: Product Introduction

This chapter describes the general features of the server, including sections on front panel and rear panel specifications.

2. Chapter 2: Hardware Information

This chapter lists the hardware setup procedures that you have to perform when installing or removing system components.

3. Chapter 3: Installation Options

This chapter describes how to install optional components into the barebone server.

4. Chapter 4: Motherboard Information

This chapter includes the motherboard layout and brief descriptions of the jumpers and internal connectors.

5. Chapter 5: BIOS Setup

This chapter tells how to change system settings through the BIOS Setup menus and describes the BIOS parameters.

6. Chapter 6: RAID Configuration

This chapter provides instructions for setting up, creating and configuring RAID sets using the available utilities.

7. Chapter 7: Driver Installation

This chapter provides instructions for installing the necessary drivers for different system components.

Conventions

To ensure that you perform certain tasks properly, take note of the following symbols used throughout this manual.



DANGER/WARNING: Information to prevent injury to yourself when trying to complete a task.



CAUTION: Information to prevent damage to the components when trying to complete a task.



IMPORTANT: Instructions that you **MUST** follow to complete a task.



NOTE: Tips and additional information to help you complete a task.

Typography

Bold text

Indicates a menu or an item to select.

Italics

Used to emphasize a word or a phrase.

<Key>

Keys enclosed in the less-than and greater-than sign means that you must press the enclosed key.

Example: <Enter> means that you must press the Enter or Return key.

<Key1>+<Key2>+<Key3>

If you must press two or more keys simultaneously, the key names are linked with a plus sign (+).

Example: <Ctrl>+<Alt>+

Command

Means that you must type the command exactly as shown, then supply the required item or value enclosed in brackets.

Example: At the DOS prompt, type the command line: `format A: /S`

References

Refer to the following sources for additional information, and for product and software updates.

1. **ASUS Control Center (ACC) user guide**

This manual tells how to set up and use the proprietary ASUS server management utility.

2. **ASUS websites**

The ASUS websites worldwide provide updated information for all ASUS hardware and software products. Refer to the ASUS contact information.

Product Introduction

1

This chapter describes the general features of the server, including sections on front panel and rear panel specifications.

1.1 System package contents

Check your system package for the following items.

Model Name	RS100-E10-PI2
Chassis	ASUS R09 1U Rackmount Chassis
Motherboard	ASUS P11C-M/4L Server Board
Component	1 x 250W Single Power Supply or 1 x 350W Single Power Supply* 2 x SATA Cables 1 x PCI Express x16 Riser Card 1 x Front I/O Board 3 x System Fans (40mm x 28mm) 1 x Fan Mylar * This item may vary according to model.
Accessories	1 x RS100-E10-PI2 Support DVD (with User's Guide) 1 x ACC Instruction Card 1 x Bag of Screws 1 x AC Power Cable 1 x CPU Heatsink
Optional Items	ASUS ASMB9-iKVM Remote management card Slim-type DVD-ROM/DVD RW Ball Bearing Rail Kit 2.5" SSD drive tray with Power and SATA cable 1 x Expansion card Fan Duct



If any of the above items is damaged or missing, contact your retailer.

1.2 Serial number label

Before requesting support from the ASUS Technical Support team, take note of the product's 12-character serial number as seen in the example xxS0xxxxxxx below. With the correct serial number of the product, ASUS Technical Support team members can quickly identify the server model and provide a satisfactory solution to your technical issue.

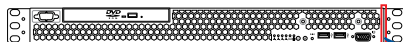

1.3 System specifications

The ASUS RS100-E10-PI2 is a 1U barebone server system featuring the ASUS P11C-M/4L server board.

Model Name		RS100-E10-PI2
Processor / System Bus		1 x Socket LGA1151 Intel® Xeon® E-21XXX processor (95W)
Core Logic		Intel® C242 Chipset
Memory	Total Slots	4 (2 Channels)
	Capacity	Maximum up to 64GB (UDIMM)
	Memory Type	DDR4 2666/2400 ECC/non-ECC UDIMM * Refer to ASUS server AVL for the latest update
	Memory Size	16GB, 8GB, 4GB (UDIMM)
Expansion Slots	Total PCI/PCI-X/PCI-E Slots	1
	Slot Type	1 x PCI-E x16 (x16 Gen3 Link)
Storage		Intel® C242: 6 x SATA 6Gb/s ports with 2 * M.2 (NGFF 22110 / 2280 / 2260 / 2242, PCI-E Gen3 x2 link or SATA signal)* Intel® RSTe (Windows & Linux) (Support software RAID 0, 1, 10 & 5) * When the M.2 is SATA signal, the gray SATA ports will be disabled.
Storage Bays		2 x 3.5" Internal HDD Bays (Optional 1 x 3.5" HDD + 2 x 2.5" SSD) 2 x M.2 (NGFF 22110 / 2280 / 2260 / 2242)
Networking	LAN	4 x Intel® I210AT 1 x Mgmt LAN
	VGA	Aspeed AST2500
Auxiliary Storage FDD / CD / DVD		1 x Slim-type Optical Device Bay (Options: No ODD / DVD-ROM / DVD-RW)
Front I/O		2 x USB 3.1 Gen 1 ports 1 x VGA port"
Rear I/O Ports		2 x USB 3.1 Gen 2 ports 2 x USB 3.1 Gen 1 ports 1 x VGA port 1 x External Serial Port 4 x RJ-45 ports 1 x RJ-45 ports (One for ASMB9-iKVM) (Optional)

(continued on the next page)

Switch/LED		Rear Switch/LED: 1 x Q-Code/Port 80 LED 1 x Power switch Front Switch/LED: 1 x Power switch/LED 1 x Location switch/LED 1 x Reset switch 1 x HDD Access LED 1 x Message LED LAN 1-4 LED
OS Support		Windows® Server 2016 RedHat® Enterprise Linux SuSE® Linux Enterprise Server CentOS VMware Citrix XenServer *Supported OS versions are subject to change without notice
Management Solution	Out of Band Remote Hardware	Optional ASMB9-iKVM for KVM-over-IP
	Software	ASUS Control Center
Net Weight Kg (CPU, DRAM & HDD not included)		7.5 Kg
Dimensions (DD x WW x HH)		380mm x 430mm x 44mm
Power Supply and Ratings		250W Single Power Supply Rating: 100-240Vac,4A ,50-60Hz, Class I
Environment		Operation temperature: 10°C–35°C Non-operating temperature: -40°C–70°C Non-operation humidity: 20%–90% (Non-condensing)

*Specifications are subject to change without notice.

1.4 Front panel features

This barebone server has a simple yet stylish front panel with easily accessible features. The power and reset buttons, LED indicators, optical drive, and two USB ports are located on the front panel.



Refer to section 1.7.1 **Front panel LEDs** for the LED descriptions.

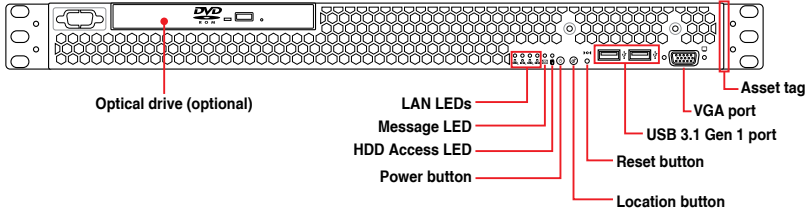

Turn off the system power and detach the power supply before removing or replacing any system component.

1.5 Rear panel features

The rear panel has the AC power socket and access to any added expansion cards. The I/O shield with openings for the rear panel connectors on the motherboard are also found in the rear panel.

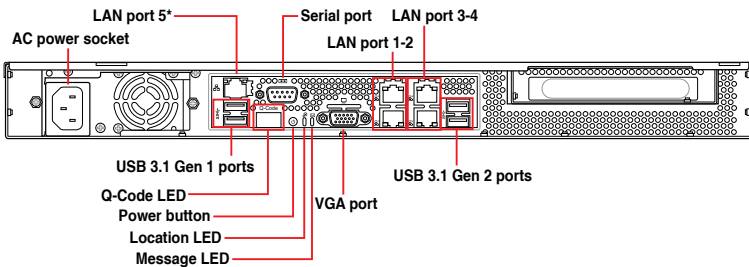

*This port is for an ASUS ASMB9-iKVM controller card only.

1.6 Internal features

The barebone server includes the basic components as shown.

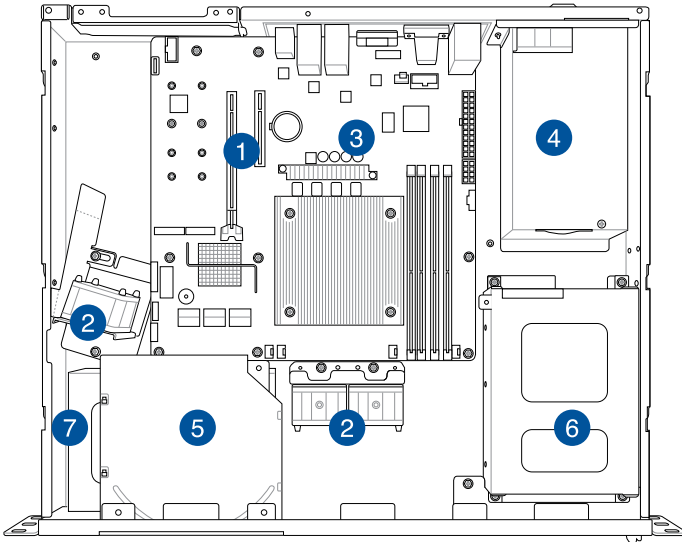

1. PCI-E Gen3 x16 Slot with Riser Card (at x8 link)
2. System Fan
3. ASUS P11C-M/4L Server board
4. Power Supply
5. Slim-type Optical Drive (Optional)
6. HDD Bay 2
7. HDD Bay 1 (partly hidden)



Turn off the system power and detach the power supply before removing or replacing any system component.



This barebone server does not include a floppy disk drive. Connect a USB floppy disk drive to any of the USB ports on the front or rear panel if you need to use a floppy disk.





WARNING

**HAZARDOUS MOVING PARTS
KEEP FINGERS AND OTHER BODY PARTS AWAY**

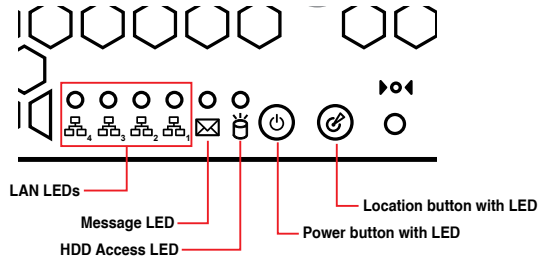
1.7 LED information



1.7.1 Front panel LEDs

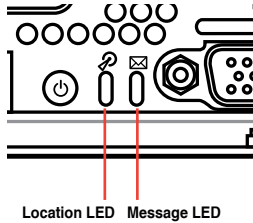

LED	Icon	Display status	Description
Power LED		ON	System power ON
HDD Access LED		OFF	No activity
		Blinking	Read/write data into the HDD
Message LED		OFF	System is normal; no incoming event
		ON	A hardware monitor event is indicated
Location LED		OFF	Normal status
		ON	Location switch is pressed (Press the location switch again to turn off)
LAN LEDs		OFF	No LAN connection
		Blinking	LAN is transmitting or receiving data
		ON	LAN connection is present

1.7.2 Rear panel LEDs



LED	Icon	Display status	Description
Location LED		OFF	Normal status
		ON	Location switch is pressed (Press the location switch again to turn off)
Message LED		OFF	System is normal; no incoming event
		ON	A hardware monitor event is indicated

1.7.3 LAN (RJ-45) LEDs

LAN port LED indications

Activity/Link LED		Speed LED	
Status	Description	Status	Description
OFF	No link	OFF	10 Mbps connection
ORANGE	Linked	ORANGE	100 Mbps connection
BLINKING	Data activity	GREEN	1 Gbps connection

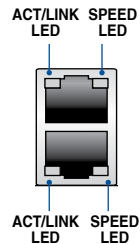

Dedicated Management LAN port (DM_LAN1) LED indications

Activity/Link LED		Speed LED	
Status	Description	Status	Description
OFF	No link	OFF	10 Mbps connection
ORANGE	Linked	ORANGE	100 Mbps connection
BLINKING	Data activity	GREEN	1 Gbps connection

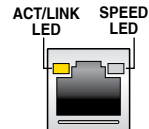

Hardware Information

2

This chapter lists the hardware setup procedures that you have to perform when installing or removing system components.

2.1 Chassis cover

2.1.1 Removing the chassis cover



- Unplug the power cord before removing the chassis cover.
- Take extra care when removing the chassis cover. Keep your fingers away from components inside the chassis that can cause injury, such as the CPU fan, rear fan, and parts with sharp or protruding edges.
- The images of the barebone server shown in this section are for reference purposes only and may not exactly match the model you purchased.

To remove the chassis cover:

1. Use a Phillips screwdriver to remove the three screws on the chassis cover.

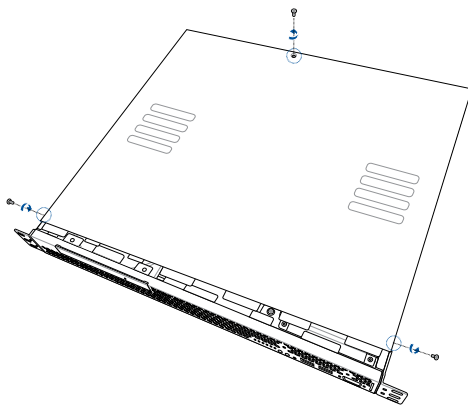

2. Firmly hold the cover and slide it toward the rear panel for about half an inch until it is disengaged from the chassis. Then, lift the cover from the chassis.

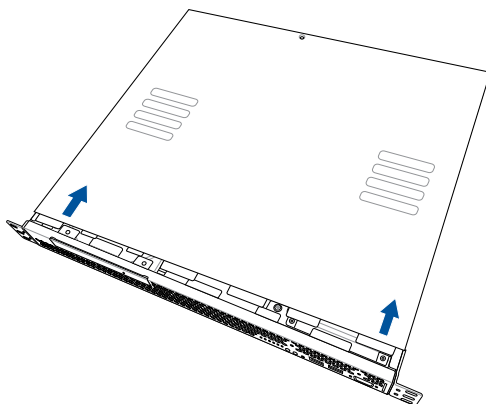

2.1.2 Reinstalling the chassis cover

To reinstall the chassis cover:

1. Position the cover on top of the chassis with the hooks aligned to the side tabs of the chassis.

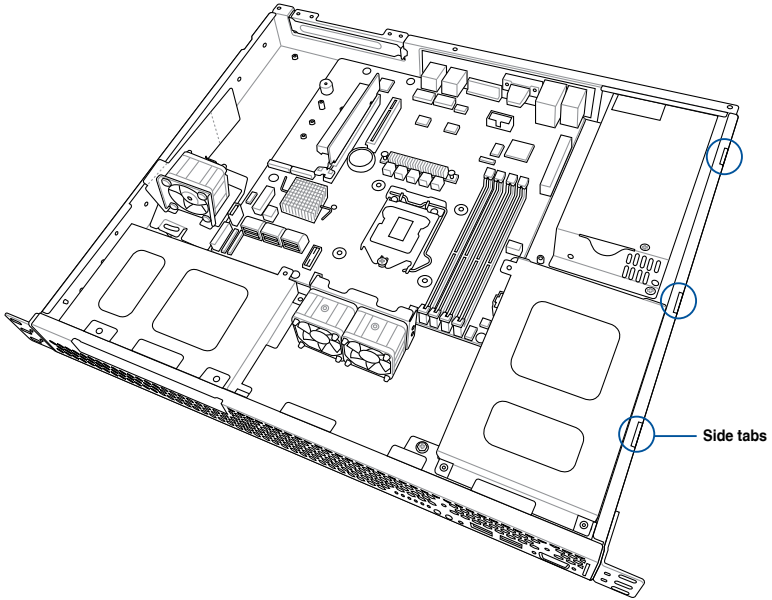

2. Slide the cover toward the front until it snaps in place.

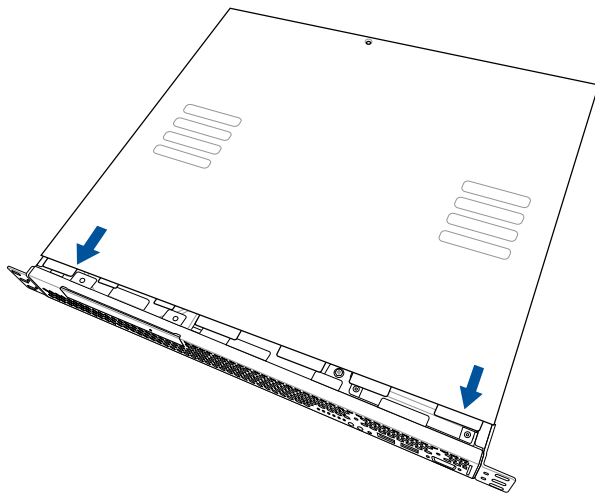

3. Secure the cover with three screws.

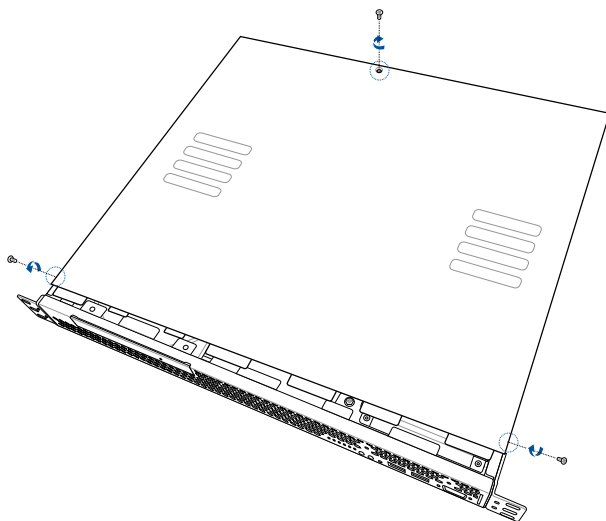

2.2 Central Processing Unit (CPU)

The motherboard comes with a surface mount LGA1151 socket designed for the Intel® Xeon® E-21xx, Intel® Core™ i3, Intel® Pentium™, and Intel® Celeron™ processors.



- Upon purchase of the motherboard, ensure that the PnP cap is on the socket and the socket contacts are not bent. Contact your retailer immediately if the PnP cap is missing, or if you see any damage to the PnP cap/socket contacts/motherboard components. ASUS will shoulder the cost of repair only if the damage is shipment/transit-related.
- The product warranty does not cover damage to the socket contacts resulting from incorrect CPU installation/removal, or misplacement/loss/incorrect removal of the PnP cap.

2.2.1 Installing the CPU

To install the CPU:

1. Locate the CPU socket on the motherboard.

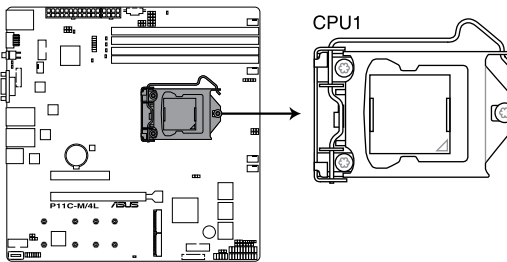

P11C-M/4L CPU LGA1151



Before installing the CPU, ensure that the socket box is facing toward you and the load lever is on your right.

2. Press the load lever with your thumb (A), then move it to the right (B) until it is released from the retention tab.



Do not remove the PnP cap yet from the CPU socket. Doing so may bend the pins of the socket.

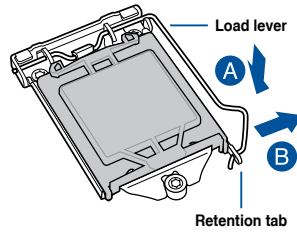

3. Lift the load lever until the load plate is completely lifted.

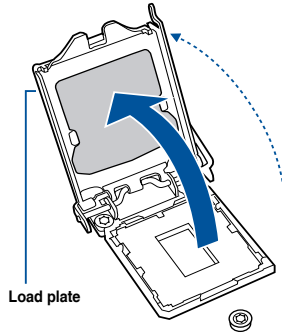

4. Position the CPU above the socket, ensuring that the gold triangle mark is on the bottom-left corner of the socket, then fit the CPU notches to the socket's alignment keys.



The CPU fits in only one orientation. DO NOT force the CPU into the socket to prevent bending the pins on the socket and damaging the CPU.

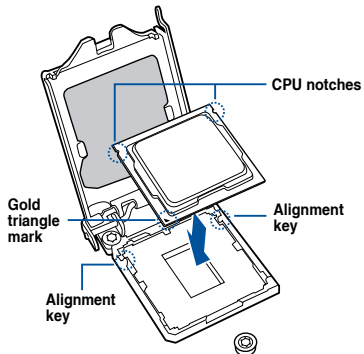

5. Close the load plate (A), ensuring that the front edge of the load plate slides under the retention lock (B) then push down the load lever (C).

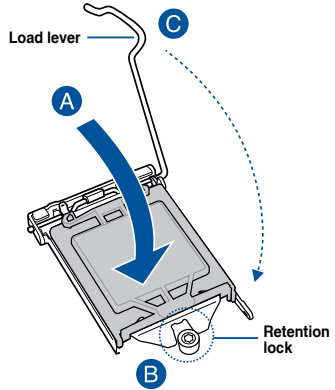

6. Insert the load lever under the retention tab to remove the PnP cap from the CPU socket.

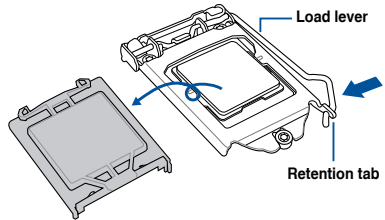

7. Apply some Thermal Interface Material to the exposed area of the CPU that the heatsink will come in contact with, ensuring that it is evenly spread in a thin layer.



Skip this step if the heatsink comes with pre-applied Thermal Interface Material.



The Thermal Interface Material is toxic and inedible. DO NOT eat it. If it gets into your eyes or touches your skin, wash it off immediately and seek professional medical help.

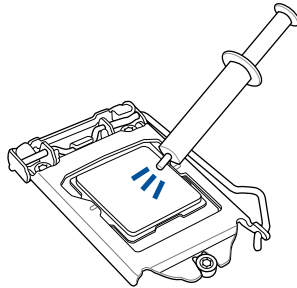

2.2.2 Installing the CPU heatsink

To install the CPU heatsink:

1. Remove the protection sticker from the back of the CPU heatsink.
2. Place the heatsink on top of the installed CPU, ensuring that the four fasteners match the holes on the motherboard.

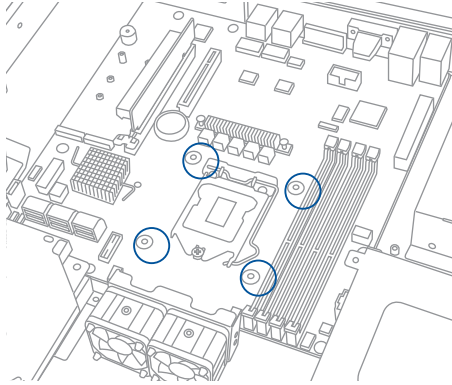

3. Using a Phillips screwdriver, lightly screw on the heatsink onto the motherboard using all four screws. Once all four screws are attached, tighten the four heatsink screws in a diagonal sequence until the heatsink is secured on the motherboard.

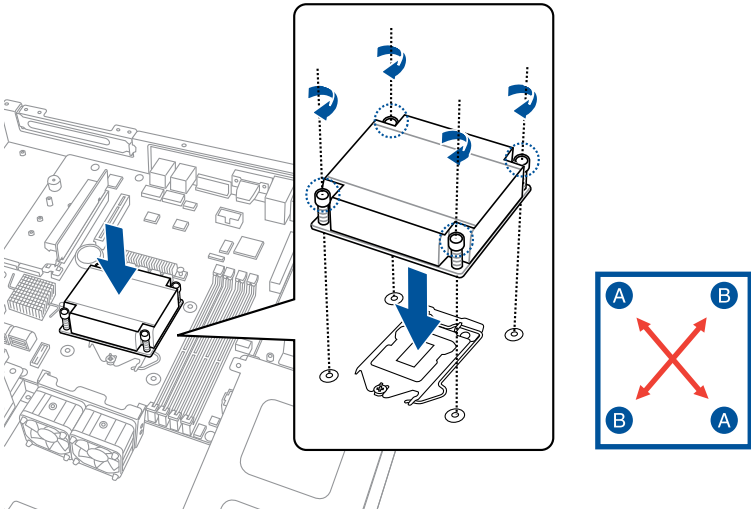

To install the airduct:

1. Locate and remove the screw from the motherboard.

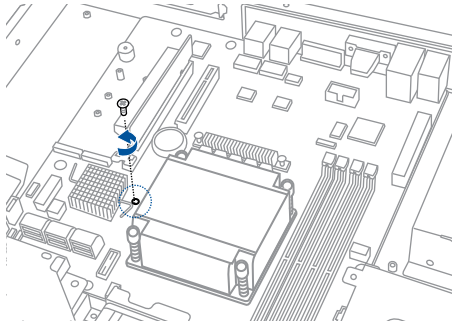

2. Place the airduct over the heatsink. The fastener on the airduct should align with the screw hole on the motherboard. Reattach the screw and secure the airduct onto the motherboard.

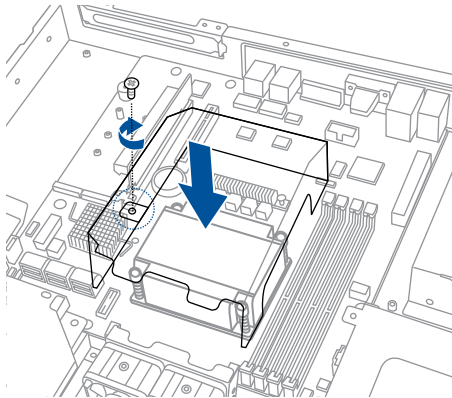

2.3 System memory

2.3.1 Overview

The motherboard comes with four (4) Double Data Rate 4 (DDR4) Dual Inline Memory Modules (DIMM) sockets.



A DDR4 module is notched differently from a DDR, DDR2, or DDR3 module. DO NOT install a DDR, DDR2, or DDR3 memory module to the DDR4 slot.

The figure illustrates the location of the DDR4 DIMM sockets:

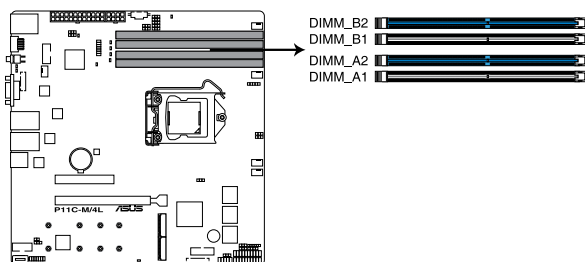

P11C-M/4L 288-pin DDR4 DIMM sockets

2.3.2 Memory configurations

You may install unbuffered DDR4 DIMMs into the DIMM sockets using the memory configurations in this section.

UDIMM				
DIMM Slot Per Channel	DIMM Populated per Channel	DIMM Type	Speed	Rank per DIMM
2	1	Unbuffered DDR4	2666	Single Rank, Dual Rank
2	2	Unbuffered DDR4	2666	Single Rank, Dual Rank



- Always install DIMMs with the same CAS latency. For optimum compatibility, it is recommended that you obtain memory modules from the same vendor.
- Start installing the DIMMs in slots A2 and B2 (Blue).

2.3.3 Installing a DIMM on a single clip DIMM socket

1. Unlock a DIMM socket by pressing the retaining clip outward.
2. Align a DIMM on the socket such that the notch on the DIMM matches the DIMM slot key on the socket.

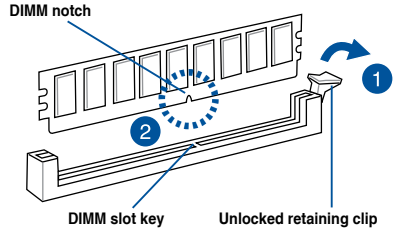

A DIMM is keyed with a notch so that it fits in only one direction. DO NOT force a DIMM into a socket in the wrong direction to avoid damaging the DIMM.

3. Hold the DIMM on both ends then insert the DIMM vertically into the socket. Apply force to both ends of the DIMM simultaneously until the retaining clip snaps back into place and the DIMM cannot be pushed in any further to ensure proper seating of the DIMM.

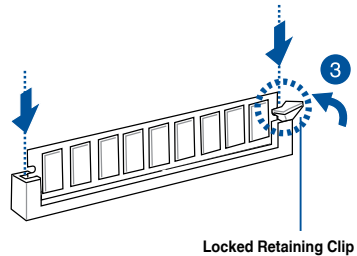

Always insert the DIMM into the socket vertically to prevent DIMM notch damage.



- To install two or more DIMMs, refer to the user guide bundled in the motherboard package.
- Refer to the user guide for the Qualified Vendor List (QVL) of the memory modules.

Removing a DIMM from a single clip DIMM socket

1. Press the retaining clip outward to unlock the DIMM.
2. Remove the DIMM from the socket.

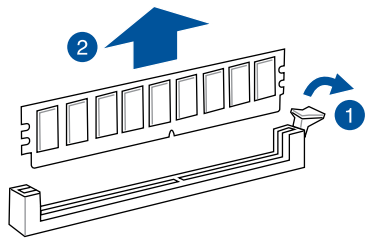

Support the DIMM lightly with your fingers when pressing the retaining clips. The DIMM might get damaged when it pops out with extra force.

2.4 Hard disk drives

The server chassis has two HDD bays for installing HDDs to the system. Both HDD bays can support 3.5-inch Serial ATA HDD.

2.4.1 Installing a hard disk drive to the HDD bay 1

To install a 3.5-inch Serial ATA HDD to HDD bay 1:

1. If you have an Optical Disc Drive (ODD) installed, remove it first before installing a 3.5-inch Serial ATA HDD to HDD bay 1.

To remove the ODD:

- 1.a Locate the ODD in the server chassis.
- 1.b Release the screw that secures the ODD to the chassis and set aside.

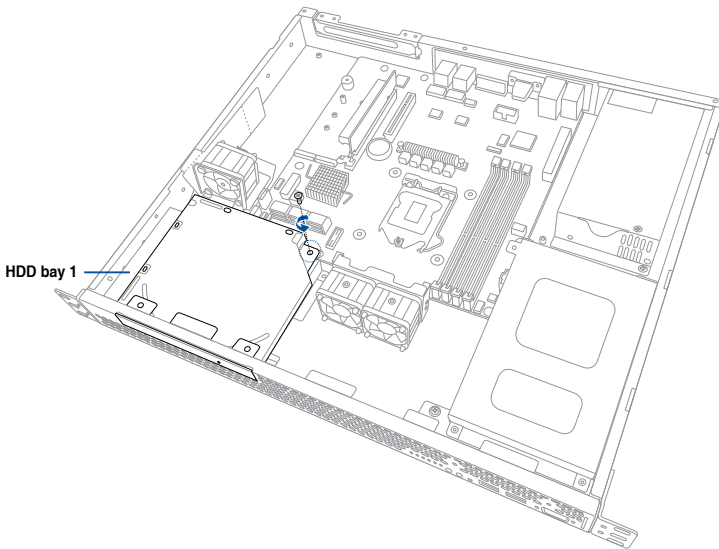

- 1.c Push the ODD outward slightly to disconnect the SATA and power cable from the ODD. Then, remove the ODD as shown.

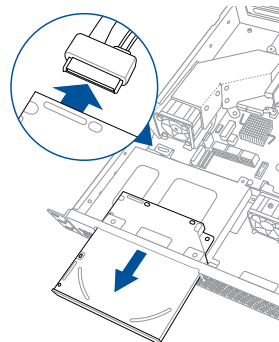

2. Release the four screws that secure the HDD drive tray to the chassis and set aside.

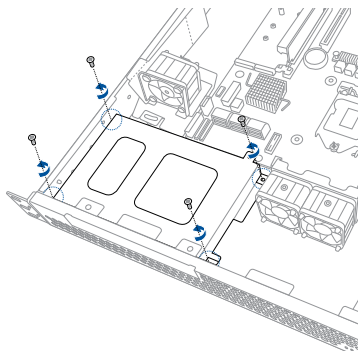

3. Remove the HDD drive tray.

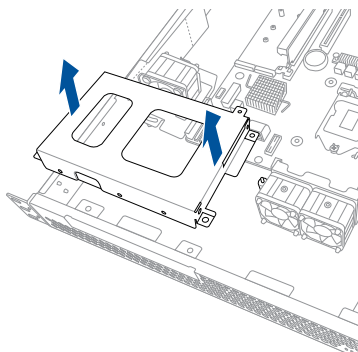

4. Insert a 3.5-inch Serial ATA HDD into the HDD drive tray.
Ensure that the 3.5-inch SATA HDD is seated securely in place.

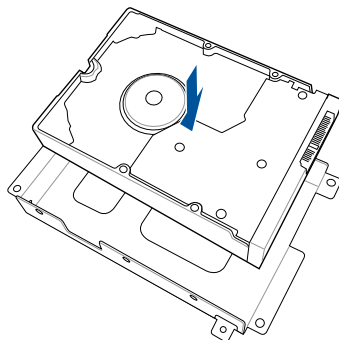

5. Secure the 3.5-inch Serial ATA HDD into the HDD drive tray using the bundled set of screws (as shown).

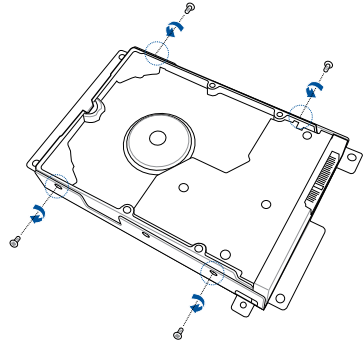

6. Place and orient the HDD drive tray and 3.5-inch SATA HDD assembly as shown.

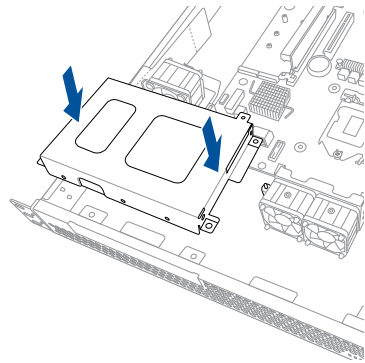

7. Connect the SATA signal cable and the power cable from the power supply to the 3.5-inch HDD.



Use an L-type SATA connector to connect the 3.5-inch SATA HDD to the motherboard.

8. Secure the 3.5-inch SATA HDD and HDD drive tray assembly to the HDD bay 1 using the screws removed in step 2.

Ensure that the HDD drive tray is seated securely in place.

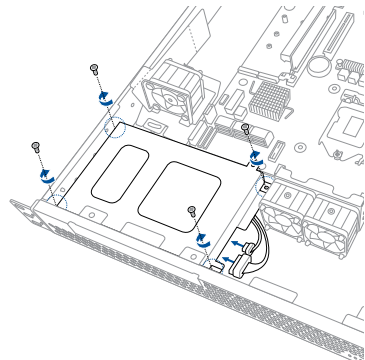

9. Reinstall the ODD back into the optical disc drive slot.

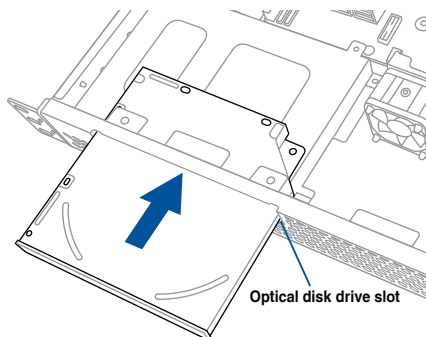

10. Connect the ODD signal cable and power cable to the ODD before sliding the optical disk drive all the way into the drive slot.
11. Secure the ODD and the HDD drive tray to HDD bay 1 using the screw removed in step 1.b.

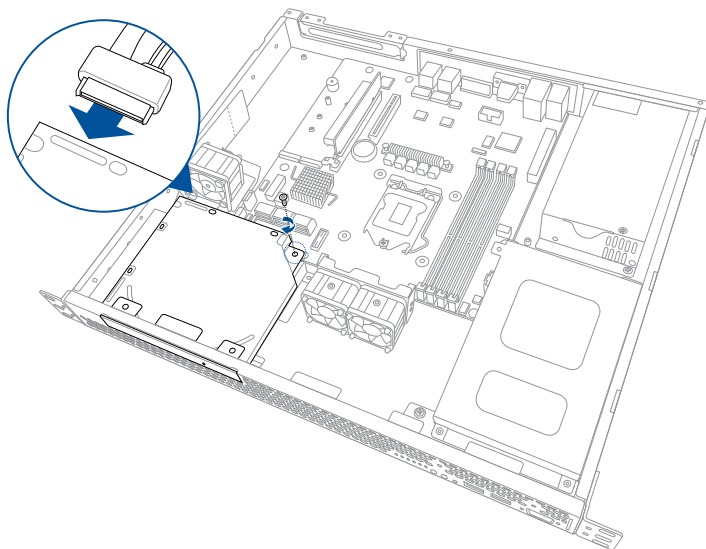

2.4.2 Installing 2.5-inch SSDs on HDD bay 1 (Optional)

To install two 2.5-inch SSDs in HDD bay 1:

1. If you have an Optical Disc Drive (ODD) installed, remove it first before installing the 2.5-inch SSDs to HDD bay 1.

To remove the ODD:

- 1.a Locate the ODD in the server chassis.
- 1.b Release the screw that secures the ODD to the chassis and set aside.

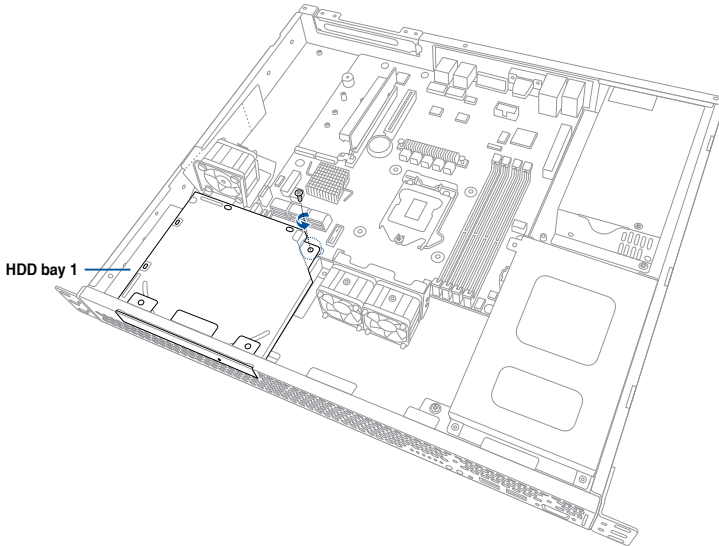

- 1.c Push the ODD outward slightly to disconnect the SATA and power cable from the ODD. Then, remove the ODD as shown.

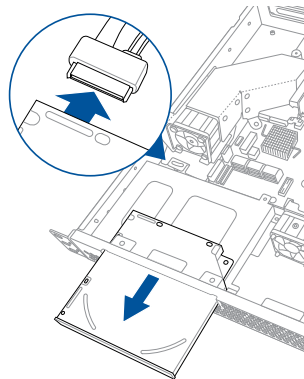

2. Prepare the SSD drive tray.
3. Place and orient two 2.5-inch SSDs on the SSD drive tray as shown.

Ensure that the screw holes on the underside of the 2.5-inch SSDs match the screw holes on the SSD drive tray.

4. Secure 2.5-inch SSDs to the SSD drive tray using four screws each.

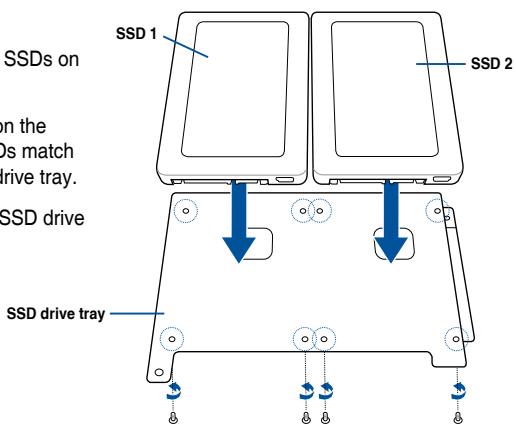

5. Carefully place the 2.5-inch SSDs and the SSD drive tray assembly into HDD bay 1.

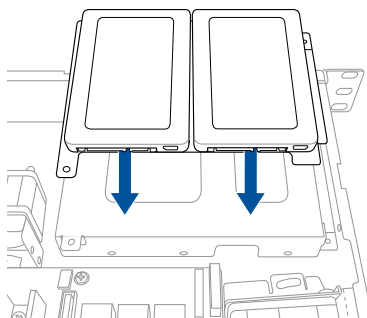

- Secure the 2.5-inch SSDs and SSD drive tray assembly to the HDD bay 1 using the bundled screw (A).

Ensure that the SSD drive tray is seated securely in place.



To secure the ODD Dummy to HDD bay 1, use the two bundled screws (B) as shown.

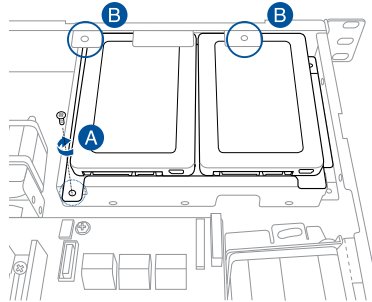

- Connect the SATA signal cable and power cable to the SSDs.

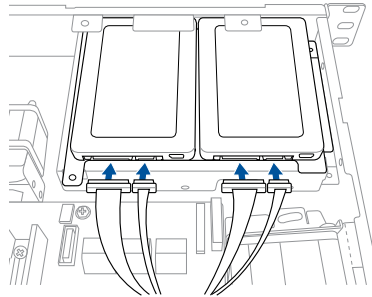

You may install either one ODD or two 2.5-inch SSDs to the reserved space in HDD bay 1. Refer to section 2.7.3 for more information.

2.4.3 Installing a 3.5-inch Serial ATA HDD to HDD bay 2

To install a 3.5-inch Serial ATA HDD to HDD bay 2:

1. Locate the HDD bay 2 in the chassis.
2. Release the four screws that secure the HDD drive tray to the chassis and set aside.

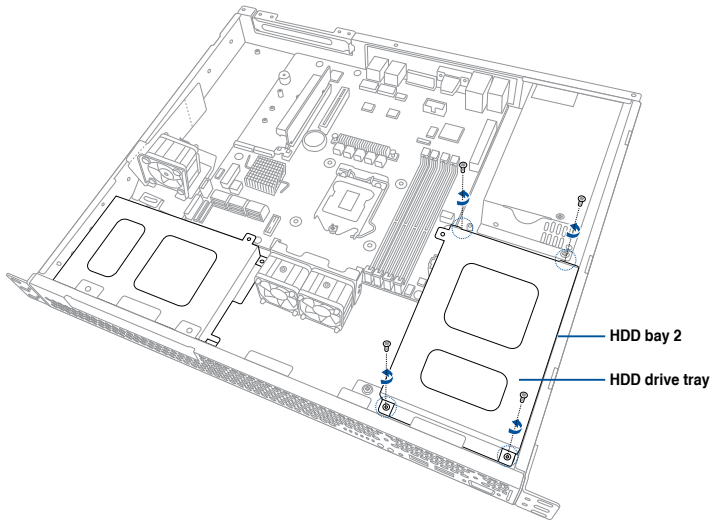

3. Remove the HDD drive tray and set aside.

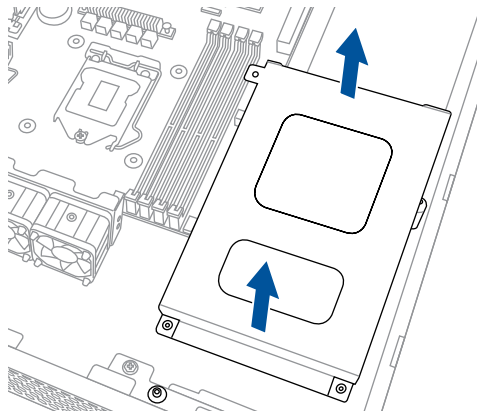

4. Insert a 3.5-inch Serial ATA HDD into the HDD drive tray.

Ensure that the 3.5-inch SATA HDD is seated securely in place.

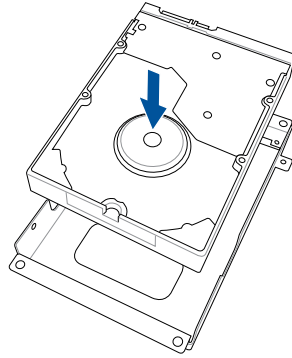

5. Secure the 3.5-inch Serial ATA HDD into the HDD drive tray using the bundled set of screws (as shown).

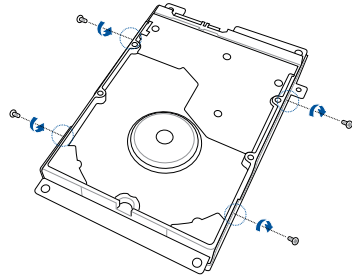

6. Connect the SATA signal cable and the power cable from the power supply to the 3.5-inch HDD.



Use an L-type SATA connector to connect the 3.5-inch SATA HDD to the motherboard.

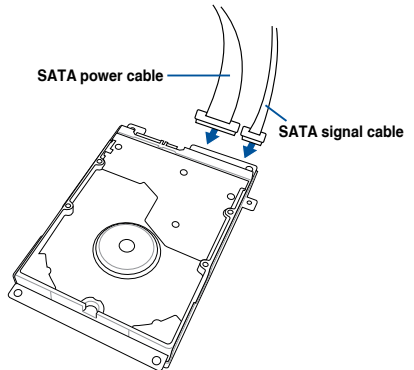

7. Place and orient the HDD drive tray and 3.5-inch SATA HDD assembly as shown.

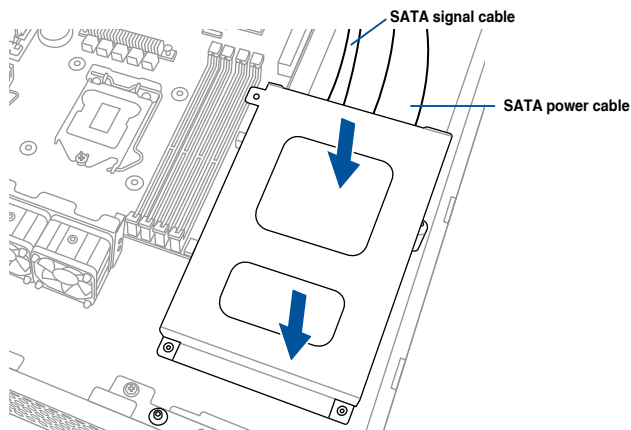

8. Secure the 3.5-inch SATA HDD and HDD drive tray assembly to the HDD bay 2 using the screws removed in step 2.

Ensure that the HDD drive tray is seated securely in place.

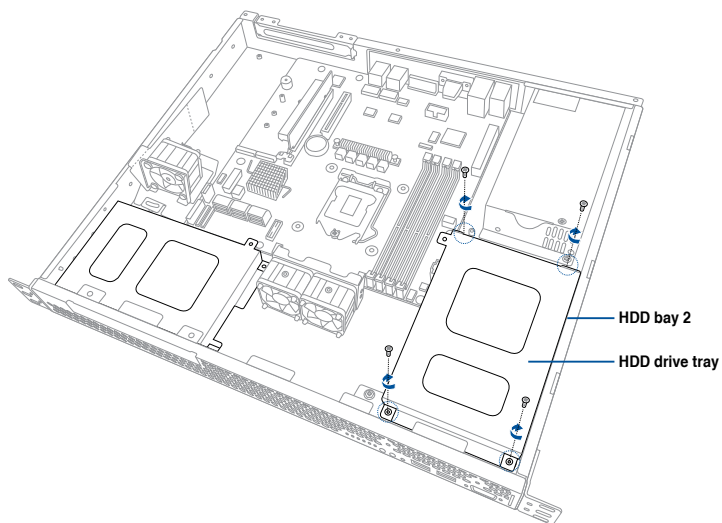

2.4.3 Installing 2.5-inch SSDs on HDD bay 2 (Optional)

To replace an installed 3.5-inch Serial ATA HDD with two 2.5-inch SSDs in HDD bay 2:

1. Locate the 3.5-inch Serial ATA HDD and the HDD drive tray assembly in the chassis.
2. Disconnect the SATA cable and power cable from the 3.5-inch SATA HDD.
3. Release the four screws that secure the HDD drive tray and 3.5-inch SATA HDD assembly to HDD bay 2 and set aside.

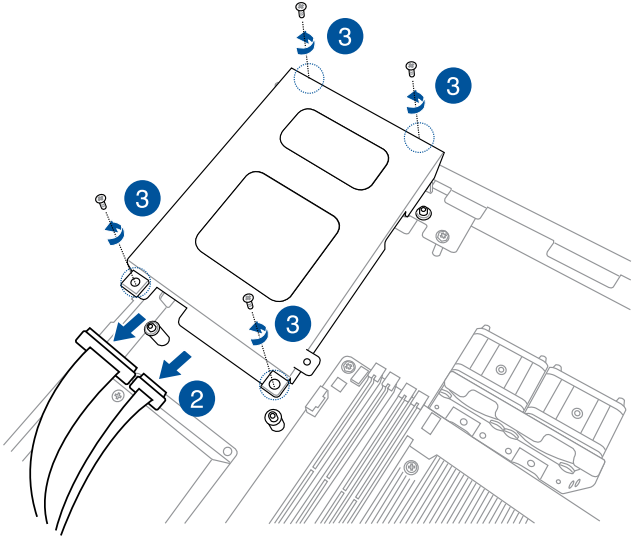

4. Remove the HDD drive tray and set aside.

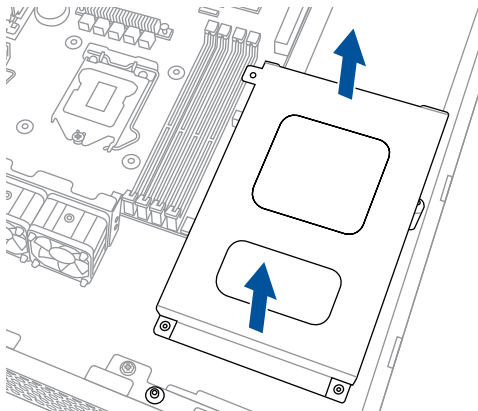

5. Prepare the SSD drive tray.
6. Place and orient two 2.5-inch SSDs on the SSD drive tray as shown.

Ensure that the screw holes on the underside of the 2.5-inch SSDs match the screw holes on the SSD drive tray.

7. Secure the 2.5-inch SSDs to the SSD drive tray using four screws each.

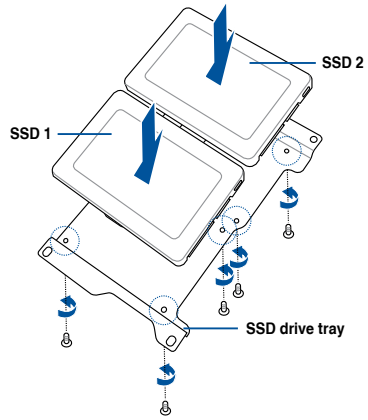

8. Carefully place the 2.5-inch SSD and the SSD drive tray assembly into HDD bay 2.
9. Secure the 2.5-inch SSD and SSD drive tray assembly to the HDD bay 2 using the screws removed in step 3.

Ensure that the SSD drive tray is seated securely in place.

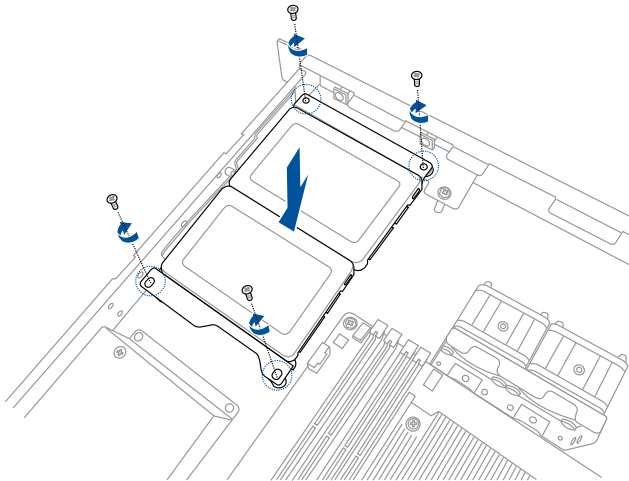

10. Connect the SATA signal cable and power cable to the 2.5-inch SSD as shown.



Use the SATA power cable that comes with the SSD drive tray as an add-on accessory.

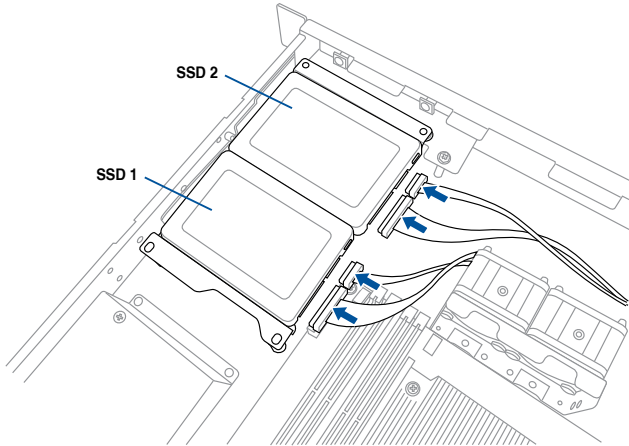

11. Connect the other end of the SATA signal cable to the SATA connector on the motherboard.
12. Connect the 4-pin power connector of the power cable to the 4-pin power connector from the power supply.

Ensure that no cables or connectors are out-of-place.

2.5 Expansion card

This system comes with a riser card. You need to remove the riser card and the expansion slot bracket if you want to install an expansion card.



Unplug the power cord before installing or removing an expansion card. Failure to do so may cause severe damage to the motherboard and other system components!

2.5.1 Installing an expansion card

To install the expansion card:

1. Hold the riser card and pull it upwards to detach it from the PCI Express slot on the motherboard.

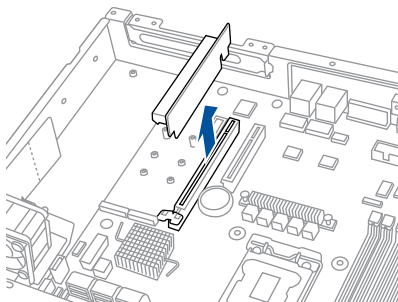

2. Remove the screw to release the expansion card bracket from the chassis.

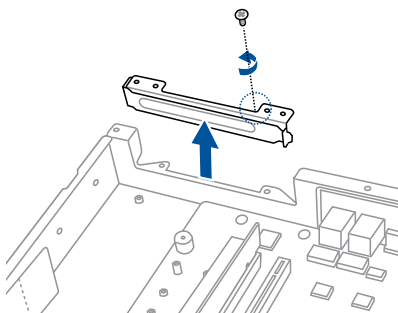

3. Remove the screw from the metal cover (A) and remove the metal cover (B) from the bracket.

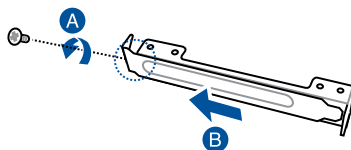

4. Install the expansion card to the bracket (A) and secure the expansion card with the screw removed in step 3 (B).
5. Install the expansion card to the riser card (C).
6. Install the expansion card and the riser card assembly into the PCIE connector on the motherboard (D).

Ensure that the golden connectors of the riser card are seated firmly in place.

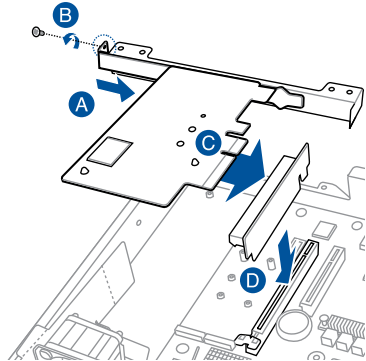

7. Secure the bracket using the screw removed in step 2.

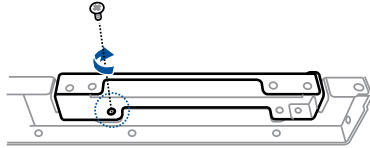

2.5.2 Configuring an expansion card

After installing the expansion card, configure the software settings if needed.

1. Turn on the system and change any necessary BIOS settings. See **Chapter 5** for information on the BIOS setup.
2. Assign an IRQ to the card. Refer to the following table.
3. Install the software drivers for the expansion card.

Standard Interrupt assignments

IRQ	Priority	Standard function
0	1	System Timer
1	2	Keyboard Controller
2	-	Programmable Interrupt
3*	-	--
4*	9	Communications Port (COM1)
5*	10	Print Port (LPT1)
6	-	--
7*	-	--
8	3	System CMOS/Real Time Clock
9*	4	ACPI Mode when used
10*	5	IRQ Holder for PCI Steering
11*	6	IRQ Holder for PCI Steering
12*	7	PS/2 Compatible Mouse Port
13	8	Numeric Data Processor
14*	-	--
15*	-	--

* These IRQs are usually available for ISA or PCI devices.

2.5.3 Installing M.2 (NGFF) cards

To install an M.2 (NGFF) card:

1. Locate the M.2 (NGFF) card connector on the motherboard.
2. Remove the screw from the motherboard.

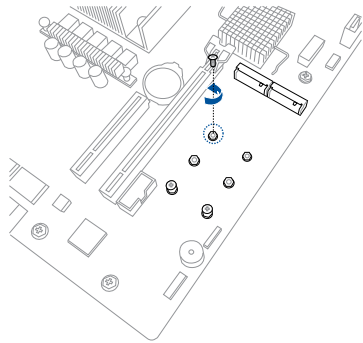

3. Prepare the M.2 card.
4. Align and insert the M.2 card into the M.2 connector on the motherboard.

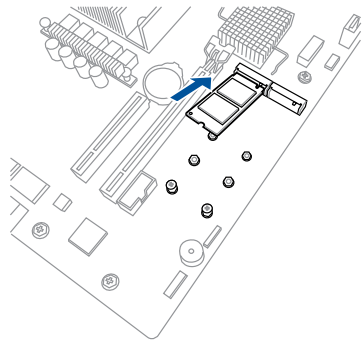

5. Secure the M.2 card to the motherboard using the screw removed in step 2.

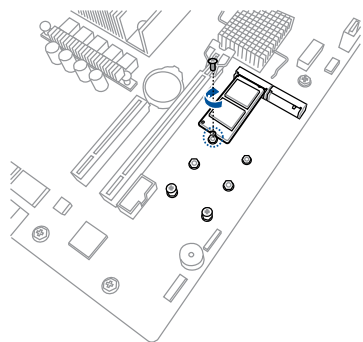

2.6 Cable connections



- The bundled system cables are set up before shipping. You do not need to disconnect these cables unless you will remove pre-installed components to install additional hardware components.
- Refer to **Chapter 4** for detailed information on the connectors.

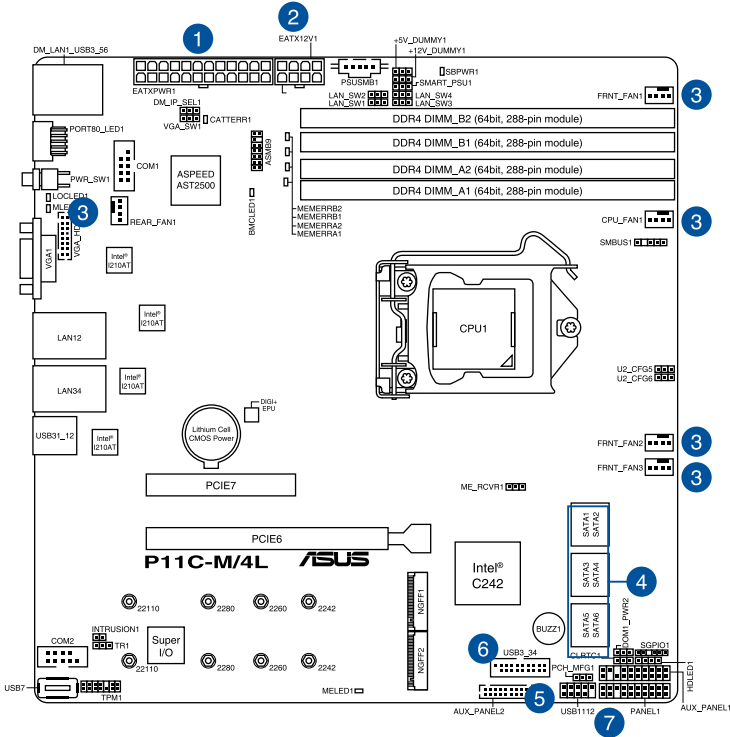

Standard cables connected to the motherboard

1. 24-pin ATX power connector (from power supply to motherboard)
2. 8-pin ATX 12V power connector (from power supply to motherboard)
3. System fans and CPU fan connectors (from motherboard to system fans)
4. SATA connectors (system default; from motherboard to SATA devices)
5. USB 2.0 connector (from motherboard to front I/O board)
6. USB 3.1 Gen 1 connector (from motherboard to front I/O board)
7. System panel connectors (from motherboard to front I/O board)

2.7 Removable/optional components

You may need to remove previously installed system components when installing or removing system devices or you may need to install optional components into the system. This section discusses how to remove/install the following components:

1. System fans
2. Expansion card airduct (optional)
3. Optical disk drive (optional)
4. ASUS ASMB9-iKVM (optional)



Ensure that the system is turned off before removing any components.

2.7.1 System fans

To install the system fans:

1. Position the system fans to match the screw holes on the chassis. Secure the fans onto the chassis using the provided screws.
2. Connect the system fan cables to the onboard fan connectors labeled FRNT_FAN2 and FRNT_FAN3.

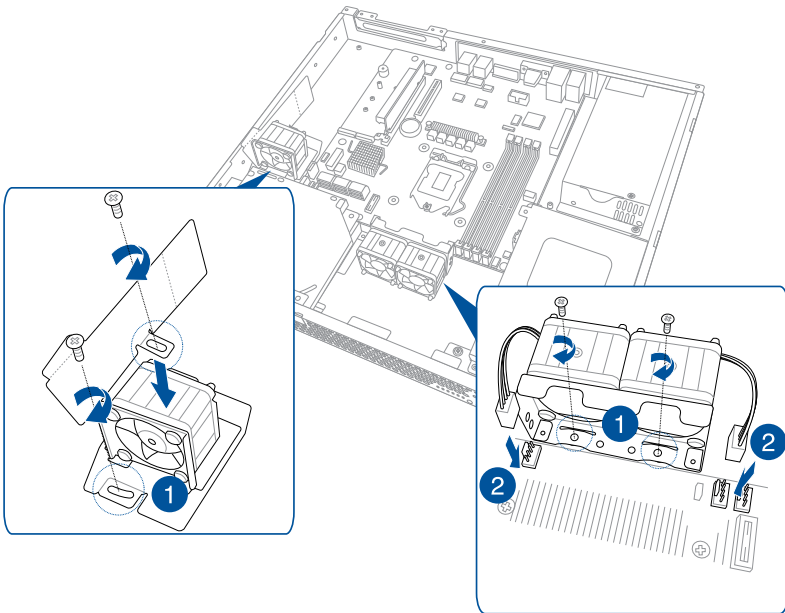

2.7.2 Optical disk drive (optional)

To install the optical disk drive:

1. Slide the optical disk drive into the drive slot.

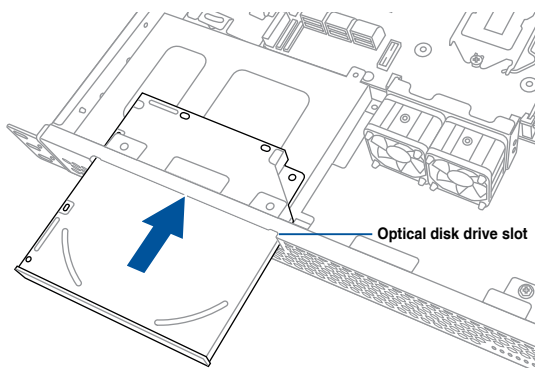

2. Connect the ODD cable to the optical disk drive before sliding the optical disk drive all the way into the drive slot.
3. Align the screw hole of the ODD bracket with the screw hole on the chassis. Secure the ODD with a screw.

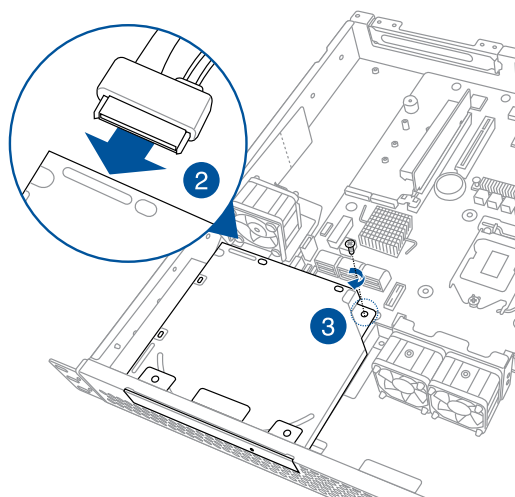

You may install either one ODD or two 2.5-inch SSDs to the reserved space in HDD bay 2. Refer to section 2.4.4 for more information.

2.7.3 Installing ASMB9 series management card (optional)

Follow the steps below to install an optional ASMB9 series management card on your motherboard.

1. Locate the ASMB9 header on the motherboard. Firmly fit the ASMB9 management card to the header. Do not force the pins when connecting the card to the motherboard header.

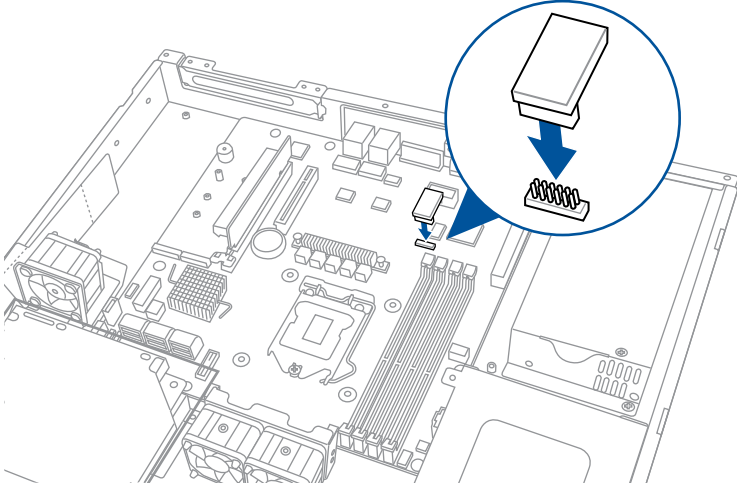

2. Insert the LAN cable plug to LAN port 5 (dedicated LAN), or LAN port 1 or LAN port 2 (shared LAN) for server management.

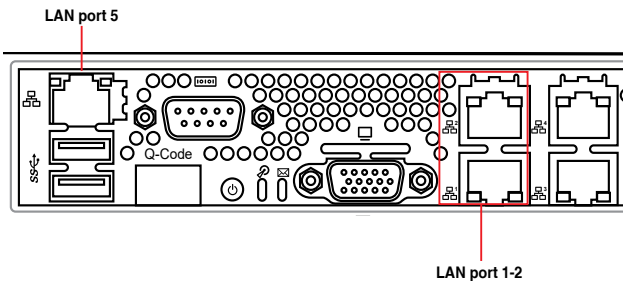

Installation Options

3

This chapter describes how to install the optional components and devices into the barebone server.

3.1 Rackmount rail kit items

The rackmount rail kit contains two pairs of rails (one pair for each side of the server system), six (6) pieces of inner rail screws, and two (2) pieces of rack screws.

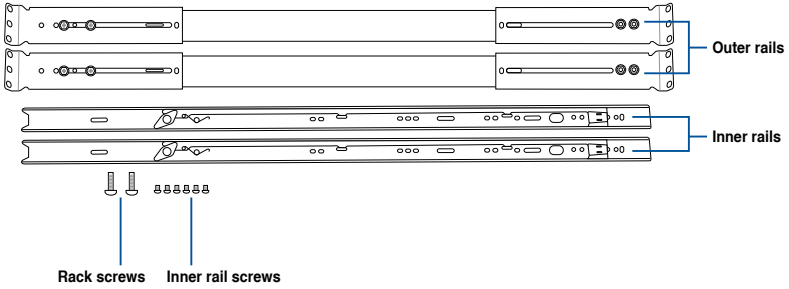

3.2 Attaching the rails to the rack

To attach the rack rails:

1. Attach the inner rail to the corresponding side of the chassis and secure with three inner rail screws. Make sure the rail is oriented as shown.

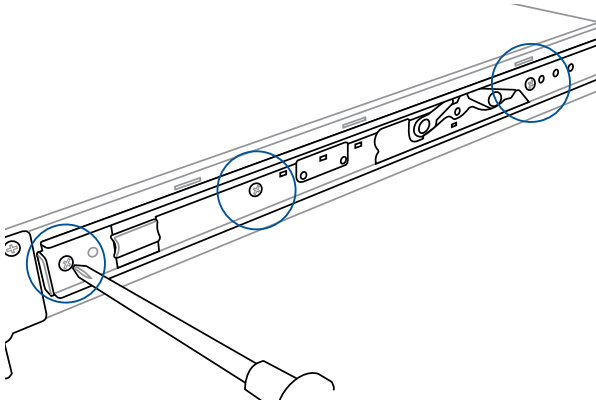

2. Attach the second inner rail to the other side of the chassis and secure with three inner rail screws.

3. Select one unit of space (1U) on the rack where you wish to install the server.

4. Place three (3) nuts on the front and three at the back. Do the same to the corresponding side of the rack.

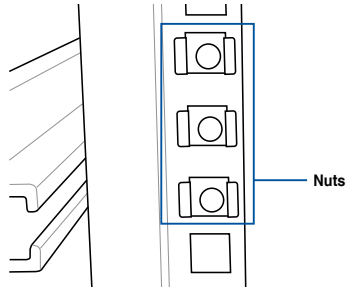

5. Adjust the length of the outer rail to fit the length of the rack cabinet, then fasten the two screws.

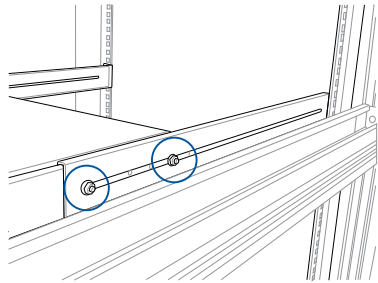

6. Secure the outer rail with two screws at the front and rear of the rack cabinet.

7. Find the corresponding 1U space on the other side of the rack cabinet then repeat steps 5 and 6 to attach the other outer rail.

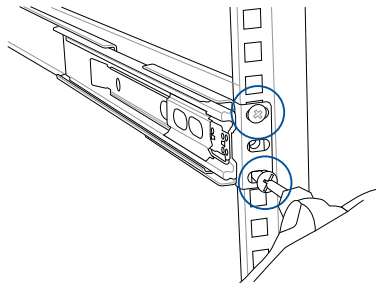

8. Firmly hold the server on both sides. Slide the latches on the inner rack rails to the direction indicated below. Hold the latches, and insert the rear side of the server to the front end of the outer rack rail.

Make sure that the inner rails are properly aligned with the outer rails.

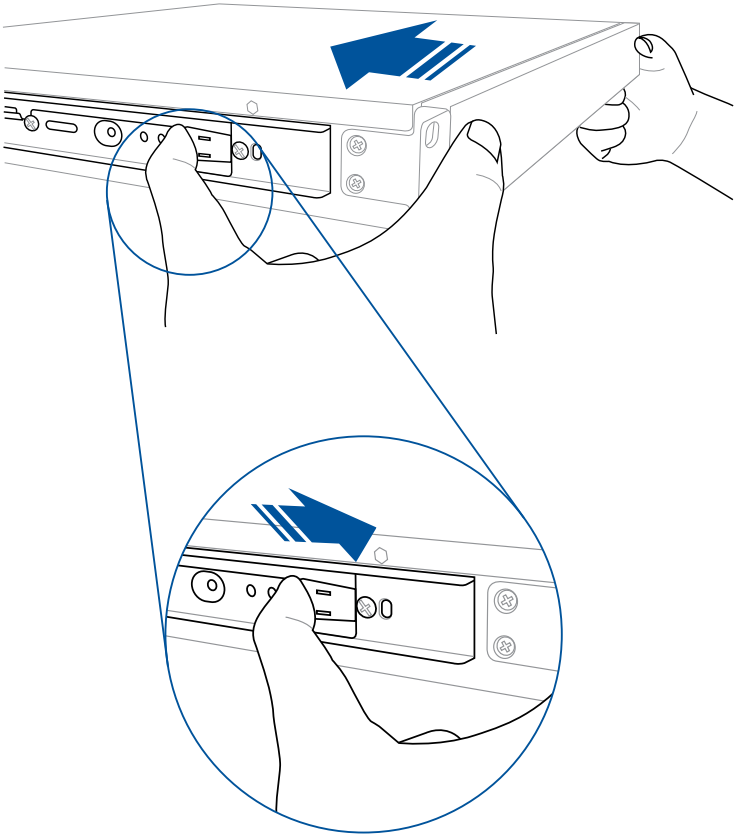

- Carefully push the server all the way to the back until the front panel fits the front end of the rack.

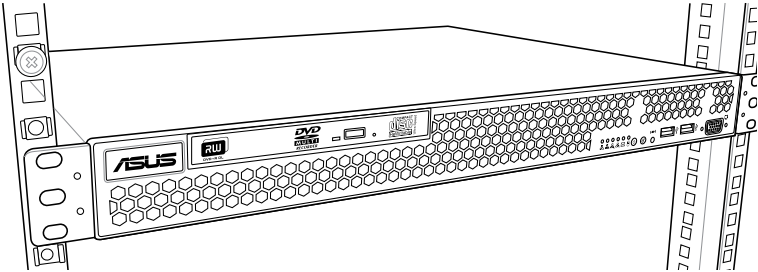

- Secure the server to the rack with one rack screw at one side. Secure the other side as well.

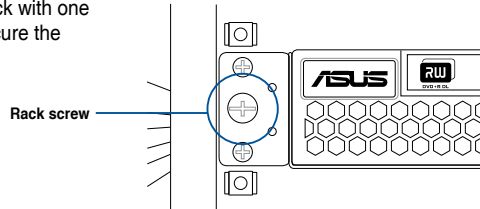

Motherboard Information

4

This chapter includes the motherboard layout and brief descriptions of the jumpers and internal connectors.

4.1 Before you proceed

Take note of the following precautions before you install motherboard components or change any motherboard settings.



- Unplug the power cord from the wall socket before touching any component.
 - Use a grounded wrist strap or touch a safely grounded object or a metal object, such as the power supply case, before handling components to avoid damaging them due to static electricity.
 - Hold components by the edges to avoid touching the ICs on them.
 - Whenever you uninstall any component, place it on a grounded antistatic pad or in the bag that came with the component.
 - Before you install or remove any component, ensure that the power supply is switched off or the power cord is detached from the power supply. Failure to do so may cause severe damage to the motherboard, peripherals, and/or components.
-

4.2 Motherboard overview

Before you install the motherboard, study the configuration of your chassis to ensure that the motherboard fits into it.

To optimize the motherboard features, we highly recommend that you install it in an ATX 1.1 compliant chassis.



Ensure to unplug the chassis power cord before installing or removing the motherboard. Failure to do so can cause you physical injury and damage motherboard components!

4.2.1 Placement direction

When installing the motherboard, ensure that you place it into the chassis in the correct orientation. The edge with external ports goes to the rear part of the chassis as indicated in the image below.

4.2.2 Screw holes

Place seven (7) screws into the holes indicated by circles to secure the motherboard to the chassis.



DO NOT overtighten the screws! Doing so can damage the motherboard.

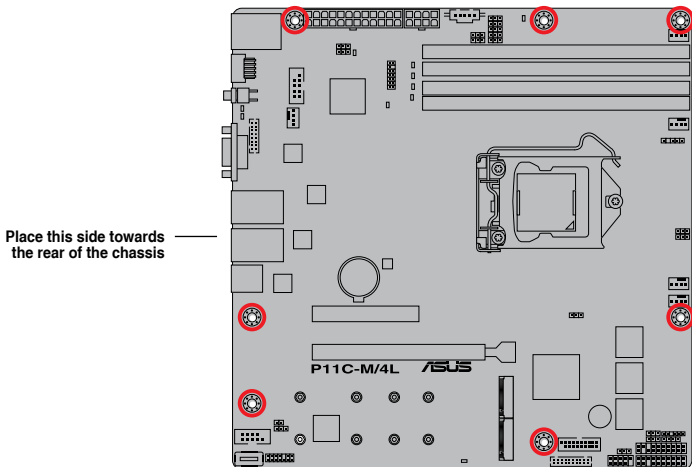

4.2.3 Motherboard layout

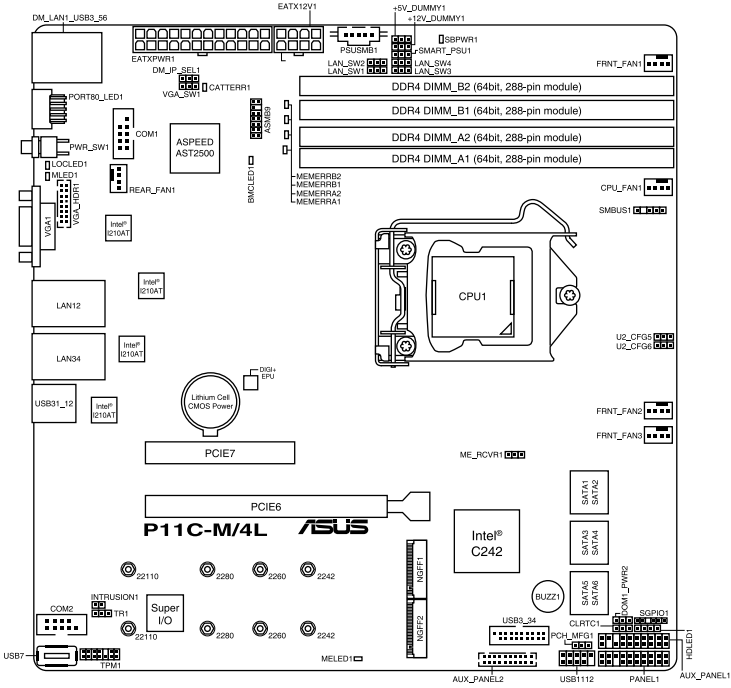

4.2.4 Layout contents

Onboard LEDs		Page
1.	Standby Power LED (SBPWR1)	4-7
2.	CATT ERR LED (CATTERR1)	4-7
3.	ME LED (MELED1)	4-8
4.	BMC LED (BMCLED1)	4-8
5.	Message LED (MLED1)	4-9

Jumpers		Page
1.	Clear RTC RAM (CLRTC1)	4-10
2.	VGA controller setting (3-pin VGA_SW1)	4-11
3.	LAN controller setting (3-pin LAN_SW1-4)	4-11
4.	ME firmware force recovery setting (3-pin ME_RCVR1)	4-12
5.	PCH_MFG1 setting (3-pin PCH_MFG1)	4-12
6.	Smart Ride Through (SmaRT) setting (3-pin SMART_PSU1)	4-13
7.	DMLAN setting (3-pin DM_IP_SEL1)	4-13
8.	SATADOM power setting (3-pin DOM1_PWR1)	4-14
9.	CPU PCIE configuration setting (3-pin U2_CFG5-6)	4-14

Rear panel connectors		Page
1.	RJ-45 port for iKVM	4-15
2.	Q-Code LED	4-15
3.	Power-on Button	4-15
4.	Video Graphics Adapter port	4-15
5.	RJ-45 ports for LAN 1-4	4-15
6.	USB 3.1 Gen 2 ports 1 and 2	4-15
7.	USB 3.1 Gen 1 ports 5 and 6	4-15

Internal connectors		Page
1.	Serial ATA 6.0 Gbp/s connectors (7-pin SATA 6Gbps_1-6)	4-19
2.	Hard disk activity LED connector (4-pin HDLED1)	4-19
3.	USB 2.0 connectors (10-1 pin USB1112; 4-pin Type-A USB7)	4-20
4.	USB 3.1 Gen 1 connector (20-1 pin USB3_34)	4-20
5.	Fan connectors (4-pin CPU_FAN1, FRNT_FAN1-3, REAR_FAN1)	4-21
6.	Serial General Purpose Input/Output connector (6-1 pin SGPIO1)	4-21
7.	Trusted Platform Module connector (14-1 pin TPM)	4-22
8.	VGA connector (16-pin VGA_HDR1))	4-22
9.	Serial port connectors (10-1 pin COM1-2)	4-23
10.	Power Supply SMBus connector (5-pin PSUSMB1)	4-23
11.	ATX power connectors (24-pin EATXPWR1, 8-pin EATX12V1)	4-24
12.	System panel connector (20-1 pin PANEL1)	4-25
13.	Auxiliary panel connectors (20-2 pin AUX_PANEL1; 20-pin AUX_PANEL2)	4-26
14.	Chassis intrusion connector (2-pin INTRUSION1)	4-27
15.	System Management Bus (SMBUS) connector (5-1 pin SMBUS1)	4-27
16.	M.2 (NGFF) connectors (NGFF1-2)	4-28
17.	Thermal sensor cable connector (3-pin TR1)	4-28

4.3 Onboard LEDs

1. Standby Power LED (SBPWR1)

The motherboard comes with a standby power LED. The green LED lights up to indicate that the system is ON, in S5 mode. This is a reminder that you should shut down the system and unplug the power cable before removing or plugging in any motherboard component. The illustration below shows the location of the onboard LED.

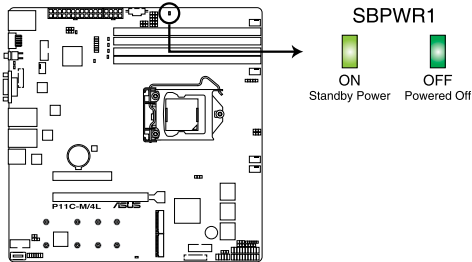

P11C-M/4L Standby Power LED

2. CATT ERR LED (CATTERR1)

The CATT ERR LED indicates that the system has experienced a fatal or catastrophic error and cannot continue to operate.

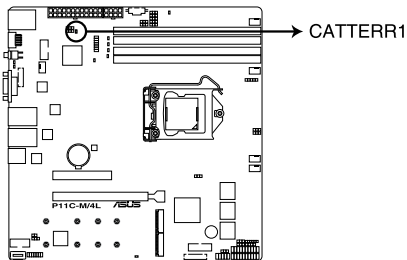

P11C-M/4L CATTERR1 LED

3. ME LED (MELED1)

The ME LED is an onboard LED that blinks when the the ME is operating properly.

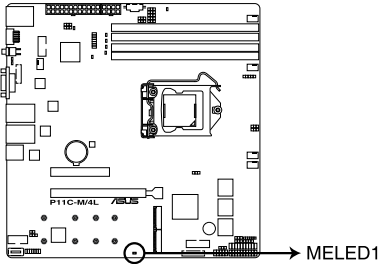

P11C-M/4L MELED1

4. BMC LED (BMCLED1)

The BMC LED blinks to indicate that the on-board BMC is functional.

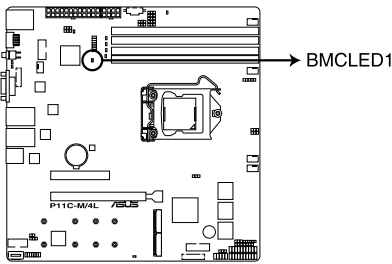

P11C-M/4L BMC LED

5. Message LED (MLED1)

This onboard LED lights up to indicate that there is a temperature warning or a BMC event log is generated.

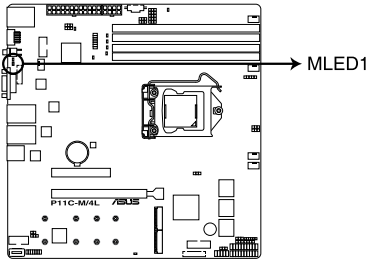

P11C-M/4L MLED1

4.4 Jumpers

1. Clear RTC RAM (3-pin CLRRTC1)

This jumper allows you to clear the CMOS memory system setup parameters by erasing the CMOS Real Time Clock (RTC) RAM data. The onboard button cell battery powers the RAM data in CMOS, which include system setup information such as system passwords.

To erase the RTC RAM:

1. Turn OFF the computer and unplug the power cord.
2. Move the jumper cap from pins 1–2 (default) to pins 2–3. Keep the cap on pins 2–3 for about 5–10 seconds, then move the cap back to pins 1–2.
3. Plug the power cord and turn ON the computer.
4. Hold down the key during the boot process and enter BIOS setup to reenter data.



Except when clearing the RTC RAM, never remove the cap on CLRRTC jumper default position. Removing the cap will cause system boot failure!



- If the steps above do not help, remove the onboard battery and short the two pins again to clear the CMOS RTC RAM data. After clearing the CMOS, reinstall the battery.
- Due to chipset behavior, AC power off is required to enable C.P.R. function. You must turn off and on the power supply or unplug and plug the power cord before rebooting the system.

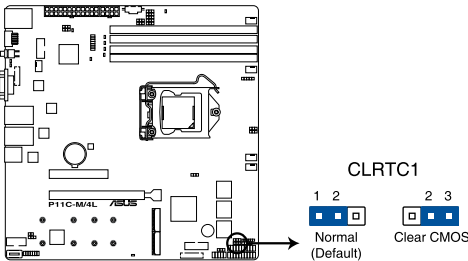

P11C-M/4L Clear RTC RAM

2. VGA controller setting (3-pin VGA_SW1)

This jumper allows you to enable or disable the onboard VGA controller. Set to pins 1–2 to activate the VGA feature.

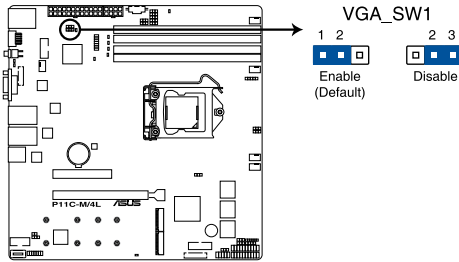

P11C-M/4L VGA setting

3. LAN controller setting (3-pin LAN_SW1-4)

These jumpers allow you to enable or disable the onboard Intel® I210 Gigabit LAN controllers. Set to pins 1-2 to activate the Gigabit LAN feature.

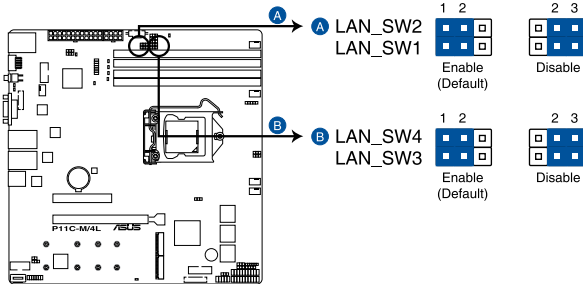

P11C-M/4L LAN setting

4. ME firmware force recovery setting (3-pin ME_RCVR1)

This jumper allows you to force Intel Management Engine (ME) boot from recovery mode when ME become corrupted.

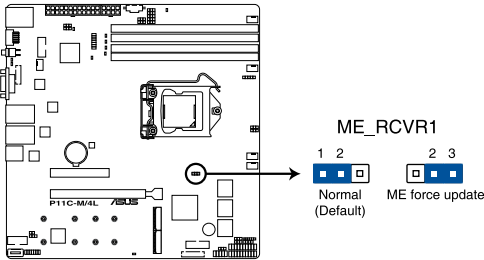

P11C-M/4L ME recovery setting

5. PCH_MFG1 setting (3-pin PCH_MFG1)

This jumper allows you to update the BIOS ME block.

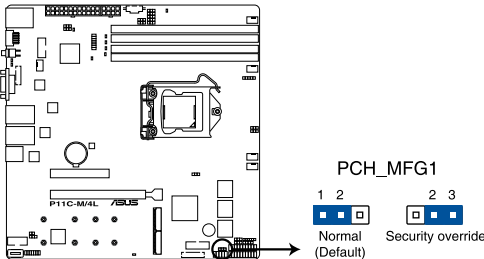

P11C-M/4L PCH_MFG1 setting

6. Smart Ride Through (SmaRT) setting (3-pin SMART_PSU1)

This jumper allows you to enable or disable the Smart Ride Through (SmaRT) function. This feature is disabled by default. Set to pins 1-2 to enable it. When enabled, SmaRT allows uninterrupted operation of the system during an AC loss event.

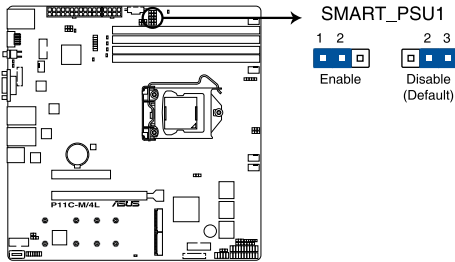

P11C-M/4L Smart Ride Through setting

7. DMLAN setting (3-pin DM_IP_SEL1)

This jumper allows you to select the DMLAN setting. Set to pins 2-3 to force the DMLAN IP to static mode (IP=10.10.10.10, submask=255.255.255.0).

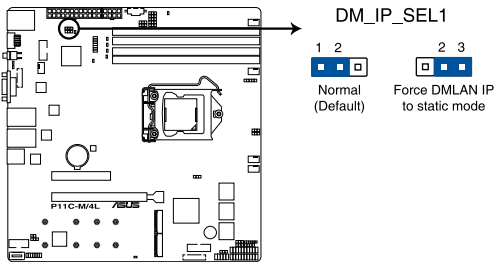

P11C-M/4L DM_IP_SEL1 setting

8. SATADOM power setting (3-pin DOM1_PWR1)

This jumper allows SATA4 to support SATADOM which do not need external power connections. Set to pins 2-3 to activate the SATA4 support feature.

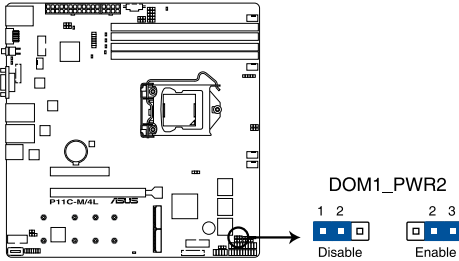

P11C-M/4L DOM PWR setting

9. CPU PCIE configuration setting (3-pin U2_CFG5-6)

These jumpers allow you to configure the speed at which PCIE6 will run at. Refer to the table below for the different jumper configurations.

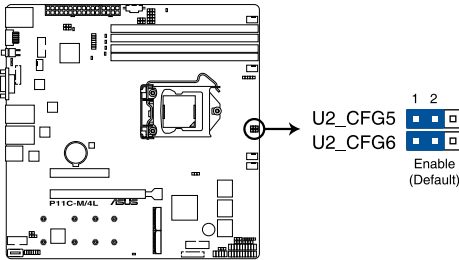

P11C-M/4L CPU PCIE CFG setting

Jumper Setting		
U2_CFG6	U2_CFG5	PCIE6 slot configuration
1 2 ■ ■ □	1 2 ■ ■ □	x16 (Default)
1 2 ■ ■ □	2 3 □ ■ ■	x8, x8
2 3 □ ■ ■	2 3 □ ■ ■	x8, x4, x4



This jumper will be disabled when PCIE7 slot is occupied.

4.5 Connectors

4.5.1 Rear panel connectors

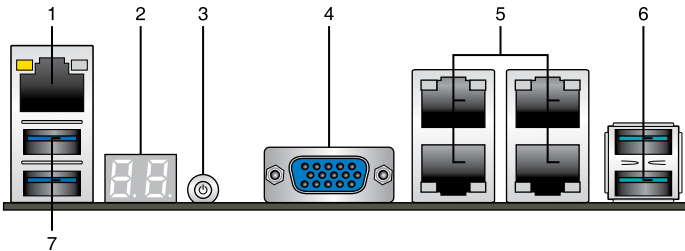

1. **RJ-45 port for iKVM.** This RJ-45 port functions only when you enable ASMB9 Management card.
2. **Q-Code LED:** The Q-Code LED provides a 2-digit display that shows the status of your system. Refer to the **Q-Code table** of this user guide for more information about the 2-digit codes.
3. **Power-on Button:** Press this button to turn on the system.
4. **Video Graphics Adapter port.** This port is for a VGA monitor or other VGA-compatible devices.
5. **RJ-45 ports for LAN 1-4.** These ports allows Gigabit connection to a Local Area Network (LAN) through a network hub. Refer to the table below for the LAN port LED indications.
6. **USB 3.1 Gen 2 ports 1 and 2.** These two 4-pin USB ports are available for connecting USB 3.1 Gen 2 devices.
7. **USB 3.1 Gen 1 ports 5 and 6.** These two 4-pin USB ports are available for connecting USB 3.1 Gen 1 devices.

LAN port LED indications

Activity/Link LED		Speed LED	
Status	Description	Status	Description
OFF	No link	OFF	10 Mbps connection
ORANGE	Linked	ORANGE	100 Mbps connection
BLINKING	Data activity	GREEN	1 Gbps connection

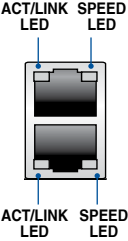

Dedicated Management LAN port (DM_LAN1) LED indications

Activity/Link LED		Speed LED	
Status	Description	Status	Description
OFF	No link	OFF	10 Mbps connection
ORANGE	Linked	ORANGE	100 Mbps connection
BLINKING	Data activity	GREEN	1 Gbps connection

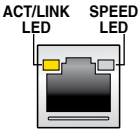

4.5.2 Q-Code table

Action	PHASE	POST CODE	TYPE	DESCRIPTION
Security Phase		1	Progress	First post code(POWER_ON_POST_CODE)
		2	Progress	Load BSP microcode(MICROCODE_POST_CODE)
		3	Progress	Perform early platform initialization
		4	Progress	Set cache as ram for PEI phase(CACHE_ENABLED_POST_CODE)
		5	Progress	Establish Stack
		6	Progress	CPU Early init.(CPU_EARLY_INIT_POST_CODE)
Normal boot	PEI(Pre-EFI initialization) phase	10	Progress	PEI Core Entry
		11	Progress	PEI cache as ram CPU initial
		15	Progress	NB initialize before installed memory
		19	Progress	SB initialize before installed memory
		0	MRC Progress	MRC_INITIALIZATION_START
		10	MRC Progress	MRC_CMD_PLOT_2D
		1B	MRC Progress	MRC_FAST_BOOT_PERMITTED
		1C	MRC Progress	MRC_RESTORE_NON_TRAINING
		1D	MRC Progress	MRC_PRINT_INPUT_PARAMS
		1E	MRC Progress	MRC_SET_OVERRIDES_PSPD
		20	MRC Progress	MRC_SPD_PROCESSING
		21	MRC Progress	MRC_SET_OVERRIDES
		22	MRC Progress	MRC_MC_CAPABILITY
		23	MRC Progress	MRC_MC_CONFIG
		24	MRC Progress	MRC_MC_MEMORY_MAP
		25	MRC Progress	MRC_JEDEC_INIT_LPDDR3
		26	MRC Progress	MRC_RESET_SEQUENCE
		27	MRC Progress	MRC_PRE_TRAINING
		28	MRC Progress	MRC_EARLY_COMMAND
		29	MRC Progress	MRC_SENSE_AMP_OFFSET
		2A	MRC Progress	MRC_READ_MPR
		2B	MRC Progress	MRC_RECEIVE_ENABLE
		2C	MRC Progress	MRC_JEDEC_WRITE_LEVELING
		2D	MRC Progress	MRC_LPDDR_LATENCY_SET_B
		2E	MRC Progress	MRC_WRITE_TIMING_1D
		2F	MRC Progress	MRC_READ_TIMING_1D
		30	MRC Progress	MRC_DIMM_ODT
		31	MRC Progress	MRC_EARLY_WRITE_TIMING_2D
		32	MRC Progress	MRC_WRITE_DS
		33	MRC Progress	MRC_WRITE_EQ
		34	MRC Progress	MRC_EARLY_READ_TIMING_2D
		35	MRC Progress	MRC_READ_ODT
		36	MRC Progress	MRC_READ_EQ
		37	MRC Progress	MRC_READ_AMP_POWER
		38	MRC Progress	MRC_WRITE_TIMING_2D
		39	MRC Progress	MRC_READ_TIMING_2D
		3A	MRC Progress	MRC_CMD_VREF
		3B	MRC Progress	MRC_WRITE_VREF_2D
		3C	MRC Progress	MRC_READ_VREF_2D
		3D	MRC Progress	MRC_POST_TRAINING
		3E	MRC Progress	MRC_LATE_COMMAND
		3F	MRC Progress	MRC_ROUND_TRIP_LAT
		40	MRC Progress	MRC_TURN_AROUND
		41	MRC Progress	MRC_CMP_OPT
		42	MRC Progress	MRC_SAVE_MC_VALUES
		43	MRC Progress	MRC_RESTORE_TRAINING
		44	MRC Progress	MRC_RMT_TOOL
		45	MRC Progress	MRC_WRITE_SR
		46	MRC Progress	MRC_DIMM_RON
		47	MRC Progress	MRC_RCVEN_TIMING_1D
48	MRC Progress	MRC_MR_FILL		
49	MRC Progress	MRC_PWR_MTR		
4A	MRC Progress	MRC_DDR4_MAPPING		
4B	MRC Progress	MRC_WRITE_VOLTAGE_1D		
4C	MRC Progress	MRC_EARLY_RDMPR_TIMING_2D		
4D	MRC Progress	MRC_FORCE_OLTM		
50	MRC Progress	MRC_MC_ACTIVATE		

(continued on the next page)

Action	PHASE	POST CODE	TYPE	DESCRIPTION
Normal boot	PEI(Pre-EFI initialization) phase	51	MRC Progress	MRC_RH_PREVENTION
		52	MRC Progress	MRC_GET_MRC_DATA
		58	MRC Progress	MRC_RETRAIN_CHECK
		5A	MRC Progress	MRC_SA_GV_SWITCH
		5B	MRC Progress	MRC_ALIAS_CHECK
		5C	MRC Progress	MRC_ECC_CLEAN_START
		5D	MRC Progress	MRC_DONE
		5F	MRC Progress	MRC_CPGC_MEMORY_TEST
		60	MRC Progress	MRC_TXT_ALIAS_CHECK
		61	MRC Progress	MRC_ENG_PERF_GAIN
		68	MRC Progress	MRC_MEMORY_TEST
		69	MRC Progress	MRC_FILL_RMT_STRUCTURE
		70	MRC Progress	MRC_SELF_REFRESH_EXIT
		71	MRC Progress	MRC_NORMAL_MODE
		7D	MRC Progress	MRC_SSA_PRE_STOP_POINT
		7E	MRC Progress	MRC_NO_MEMORY_DETECTED
		7F	MRC Progress	MRC_SSA_STOP_POINT
		55	MRC Progress	MRC_MEM_INIT_DONE
		32	Progress	CPU Init.
		34	Progress	CPU Init.
	36	Progress	CPU Init.	
	4F	Progress	DXE Initial Program Load(IPL)	
	DXE(Driver Execution Environment) phase	60	Progress	DXE Core Started
		61	Progress	DXE NVRAM Init.
		62	Progress	SB run-time init.
		63	Progress	DXE CPU Init
		68	Progress	NB Init.
		69	Progress	NB Init.
		6A	Progress	NB Init.
		70	Progress	SB Init.
		71	Progress	SB Init.
		72	Progress	SB Init.
	BDS(Boot Device Selection) phase	78	Progress	ACPI Init.
		79	Progress	CSM Init.
		90	Progress	BDS started
		91	Progress	Connect device event
		92	Progress	PCI Bus Enumeration.
		93	Progress	PCI Bus Enumeration.
		94	Progress	PCI Bus Enumeration.
		95	Progress	PCI Bus Enumeration.
		96	Progress	PCI Bus Enumeration.
		97	Progress	Console outout connect event
		98	Progress	Console input connect event
		99	Progress	AMI Super IO start
		9A	Progress	AMI USB Driver Init.
		9B	Progress	AMI USB Driver Init.
		9C	Progress	AMI USB Driver Init.
		9D	Progress	AMI USB Driver Init.
		b2	Progress	Legacy Option ROM Init.
		b3	Progress	Reset system
		b4	Progress	USB hotplug
		b6	Progress	NVRAM clean up
	b7	Progress	NVRAM configuration reset	
	A0	Progress	IDE, AHCI Init.	
	A1	Progress	IDE, AHCI Init.	
A2	Progress	IDE, AHCI Init.		
A3	Progress	IDE, AHCI Init.		
FF-00	Progress	Wait BMC ready(duration: 120 seconds).		
A8	Progress	BIOS Setup Utility password verify		
A9	Progress	BIOS Setup Utility start		
AB	Progress	BIOS Setup Utility input wait		
AD	Progress	Ready to boot event		
AE	Progress	Legacy boot event		
Operating system phase	AA	Progress	APIC mode	
	AC	Progress	PIC mode	

4.5.3 Internal connectors

1. Serial ATA 6.0 Gbp/s connectors (7-pin SATA 6Gbps_1-6)

Supported by the Intel® C242 chipset, these connectors are for the Serial ATA signal cables for Serial ATA hard disk drives that allows up to 6Gb/s of data transfer rate.

If you installed Serial ATA hard disk drives, you can create a RAID 0, RAID 1, RAID 10, or RAID 5 configuration.

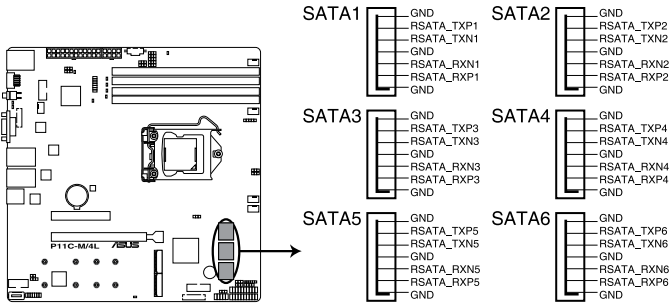

P11C-M/4L Intel® Serial ATA 6 Gb/s connectors



The actual data transfer rate depends on the speed of Serial ATA hard disks installed.

2. Hard disk activity LED connector (4-pin HDLED1)

This LED connector is for the storage add-on card cable connected to the SATA or SAS add-on card. The read or write activities of any device connected to the SATA or SAS add-on card causes the front panel LED to light up.

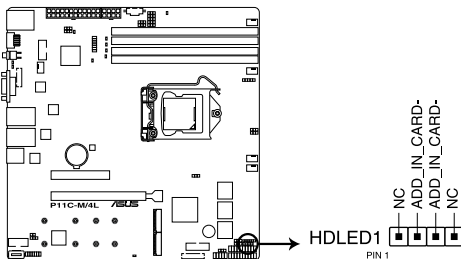

P11C-M/4L Storage device activity LED connector

3. USB 2.0 connectors (10-1 pin USB1112; 4-pin Type-A USB7)

The 10-1 pin connector allows you to connect a USB 2.0 module for additional USB 2.0 front or rear panel ports. The 4-pin USB (Universal Serial Bus) Type-A port is available for connecting USB 2.0 devices. These USB connectors comply with USB 2.0 specification that supports up to 480 Mbps connection speed.

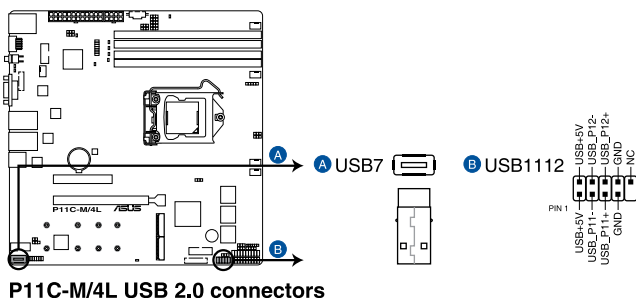

DO NOT connect a 1394 cable to the USB connectors. Doing so will damage the motherboard!

4. USB 3.1 Gen 1 connector (20-1 pin USB3_34)

This connector allows you to connect a USB 3.1 Gen 1 module for additional USB 3.1 Gen 1 front or rear panel ports. With an installed USB 3.1 Gen 1 module, you can enjoy all the benefits of USB 3.1 Gen 1 including faster data transfer speeds of up to 5 Gb/s, faster charging time for USB-chargeable devices, optimized power efficiency, and backward compatibility with USB 2.0.

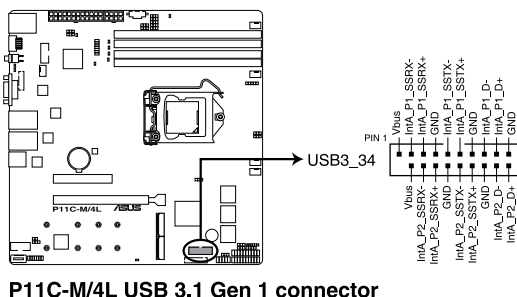

The USB 3.1 Gen 1 module is purchased separately.



The plugged USB 3.1 Gen 1 device may run on xHCI or EHCI mode depending on the operating system's setting.

5. Fan connectors (4-pin CPU_FAN1, FRNT_FAN1-3, REAR_FAN1)

The fan connectors support cooling fans. Connect the fan cables to the fan connectors on the motherboard, ensuring that the black wire of each cable matches the ground pin of the connector.



- DO NOT forget to connect the fan cables to the fan connectors. Insufficient air flow inside the system may damage the motherboard components.
- These are not jumpers! DO NOT place jumper caps on the fan connectors!
- All fans feature the ASUS Smart Fan technology.

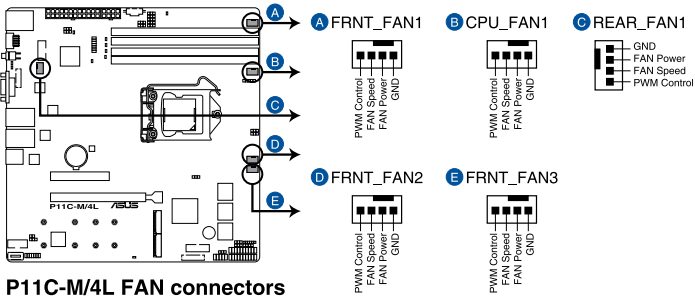

6. Serial General Purpose Input/Output connector (6-1 pin SGPIO1)

The SGPIO 1 connector is used for the Intel Rapid Storage Technology Enterprise SGPIO interface that controls the LED pattern generation, device information, and general purpose data.

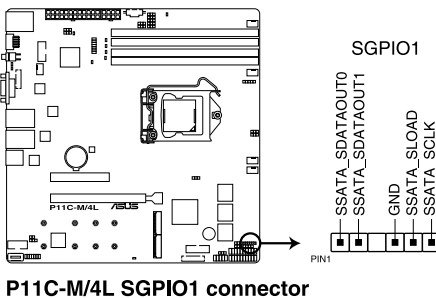

7. Trusted Platform Module connector (14-1 pin TPM1)

This connector supports a Trusted Platform Module (TPM) system, which can securely store keys, digital certificates, passwords, and data. A TPM system also helps enhance network security, protects digital identities, and ensures platform integrity.

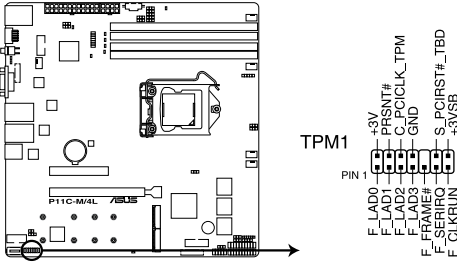

P11C-M/4L TPM connector

8. VGA connector (16-pin VGA_HDR1)

This connector supports the VGA High Dynamic-Range interface.

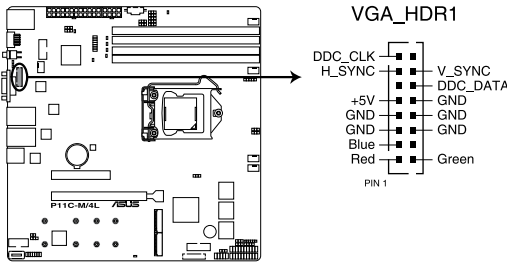

P11C-M/4L Internal VGA connector

9. Serial port connectors (10-1 pin COM1-2)

These connectors are for the serial (COM) ports. Connect the serial port module cable to the connector, then install the module to a slot opening at the back of the system chassis.

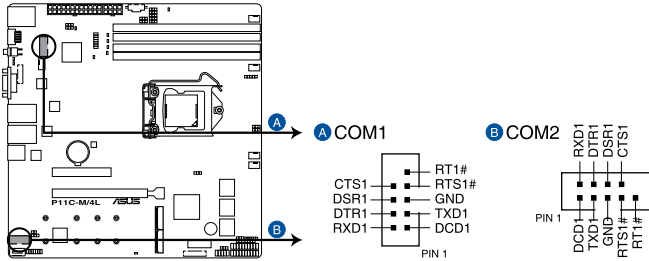

P11C-M/4L Serial port connectors

10. Power Supply SMBus connector (5-pin PSUSMB1)

This connector allows you to connect SMBus (System Management Bus) to the PSU (power supply unit) to read PSU information. Devices communicate with an SMBus host and/or other SMBus devices using the SMBus interface.

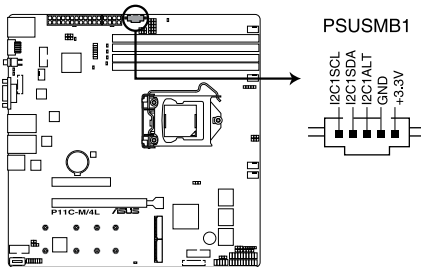

P11C-M/4L Power supply SMBus connector



This connector functions only when you enable the ASUS ASMB9.



Power supply is required to meet PMBus specification and customized BMC FW may be needed. Please contact ASUS if your need further support.

11. ATX power connectors (24-pin EATXPWR1, 8-pin EATX12V1)

These connectors are for the ATX power supply plugs. The power supply plugs are designed to fit these connectors in only one orientation. Find the proper orientation and push down firmly until the connectors completely fit.



- DO NOT forget to connect the 24-pin and the 8-pin power plugs; otherwise, the system will not boot up.
- Use of a power supply unit (PSU) with a higher power output is recommended when configuring a system with more power-consuming devices. The system may become unstable or may not boot up if the power is inadequate.
- This motherboard supports ATX2.0 PSU or later version.
- Ensure that your PSU can provide at least the minimum power required by your system.

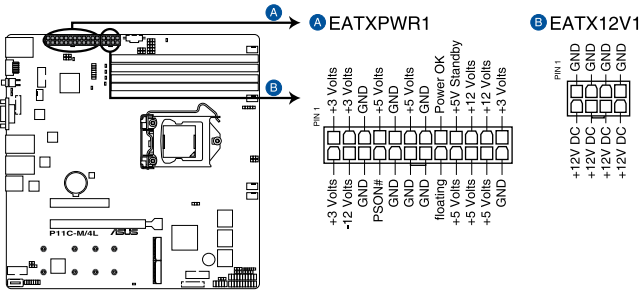

P11C-M/4L ATX power connectors

12. System panel connector (20-1 pin PANEL1)

This connector supports several chassis-mounted functions.

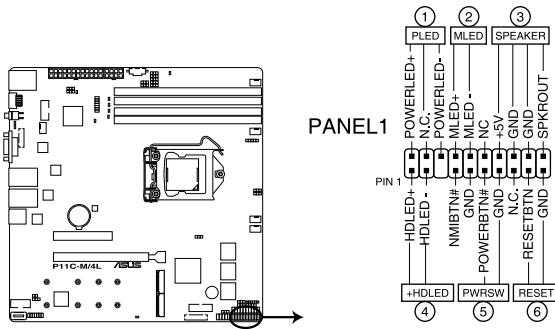

P11C-M/4L System panel connector

1. System power LED (3-pin PLED)

This 3-pin connector is for the system power LED. Connect the chassis power LED cable to this connector. The system power LED lights up when you turn on the system power, and blinks when the system is in sleep mode.

2. Message LED (2-pin MLED)

This 2-pin connector is for the message LED cable that connects to the front message LED. The message LED is controlled by Hardware monitor to indicate an abnormal event occurrence.

3. System warning speaker (4-pin SPEAKER)

This 4-pin connector is for the chassis-mounted system warning speaker. The speaker allows you to hear system beeps and warnings.

4. Hard disk drive activity LED (2-pin +HDLED)

This 2-pin connector is for the HDD Activity LED. Connect the HDD Activity LED cable to this connector. The IDE LED lights up or flashes when data is read from or written to the HDD.

5. Power button/soft-off button (2-pin PWRSW)

This connector is for the system power button. Pressing the power button turns the system on or puts the system in sleep or soft-off mode depending on the BIOS settings. Pressing the power switch for more than four (4) seconds while the system is ON turns the system OFF.

6. Reset button (2-pin RESET)

This 2-pin connector is for the chassis-mounted reset button for system reboot without turning off the system power.

13. Auxiliary panel connectors (20-2 pin AUX_PANEL1; 20-pin AUX_PANEL2)

These connectors are for additional front panel features including front panel SMB, locator LED and switch, chassis intrusion, and LAN LEDs.

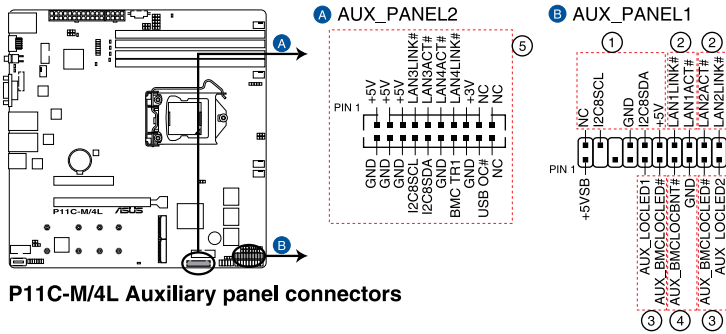

P11C-M/4L Auxiliary panel connectors

1. Front panel SMB (6-1 pin FPSMB)

This 6-1 pin connector is for the front panel SMBus cable.

2. LAN activity LED (2-pin LAN1_LED, LAN2_LED)

This 2-pin connector is for the Gigabit LAN activity LEDs on the front panel.

3. Locator LED (2-pin LOCATORLED1, 2-pin LOCATORLED2)

This 2-pin connector is for the locator LED1 and LED2 on the front panel. Connect the Locator LED cables to these 2-pin connector. The LEDs will light up when the Locator button is pressed.

4. Locator Button/Switch (2-pin LOCATORBTN)

This 2-pin connector is for the locator button on the front panel. This button queries the state of the system locator.

5. LAN activity LED and USB port (2-pin LAN3_LED, LAN4_LED, USB ports)

These leads are for the Gigabit LAN activity LEDs and USB ports on the front panel.

14. Chassis intrusion connector (2-pin INTRUSION1)

This connector is for a chassis-mounted intrusion detection sensor or switch. Connect one end of the chassis intrusion sensor or switch cable to this connector. The chassis intrusion sensor or switch sends a high-level signal to this connector when a chassis component is removed or replaced. The signal is then generated as a chassis intrusion event.

By default, the pin labeled “Chassis Signal” and “Ground” are shorted with a jumper cap. Remove the jumper caps only when you intend to use the chassis intrusion detection feature.

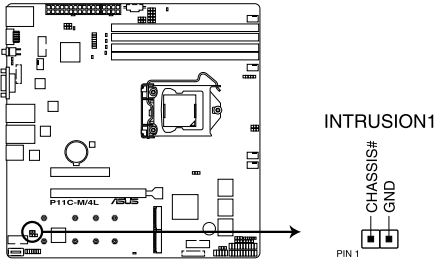

P11C-M/4L Chassis Intrusion connectors

15. System Management Bus (SMBUS) connector (5-1 pin SMBUS1)

This connector controls the system and power management-related tasks. This connector processes the messages to and from devices rather than tripping the individual control lines.

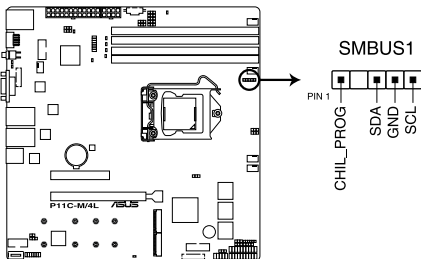

P11C-M/4L SMBUS connector

16. M.2 (NGFF) connectors (NGFF1-2)

These connectors allow you to install M.2 devices.

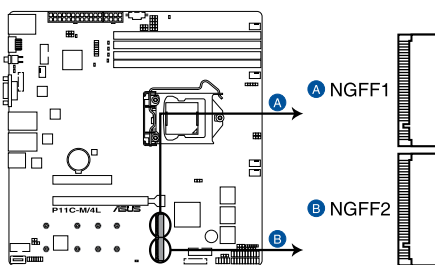

P11C-M/4L NGFF connectors



These connectors support type 2242 / 2260 / 2280 / 22110 devices on both PCIe x2 and SATA interface.



The M.2 (NGFF) device is purchased separately

17. Thermal sensor cable connector (3-pin TR1)

This connector allows you to connect a thermal sensor cable that is used for monitoring temperature. Connect the thermal sensor cable to the connector and place its probe to the device that you want to monitor.

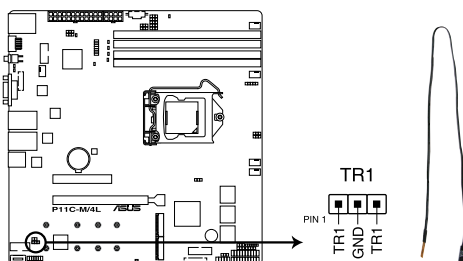

P11C-M/4L Thermal sensor cable connector

BIOS Setup

5

This chapter tells how to change the system settings through the BIOS Setup menus. Detailed descriptions of the BIOS parameters are also provided.

5.1 Managing and updating your BIOS

The following utilities allow you to manage and update the motherboard Basic Input/Output System (BIOS) setup:

1. **ASUS CrashFree BIOS 3**

To recover the BIOS using a bootable USB flash disk drive when the BIOS file fails or gets corrupted.

2. **ASUS EzFlash**

Updates the BIOS using a USB flash disk.

3. **BUPDATER**

Updates the BIOS in DOS mode using a bootable USB flash disk drive.

Refer to the corresponding sections for details on these utilities.



Save a copy of the original motherboard BIOS file to a bootable USB flash disk drive in case you need to restore the BIOS in the future. Copy the original motherboard BIOS using the BUPDATER utility.

5.1.1 **ASUS CrashFree BIOS 3 utility**

The ASUS CrashFree BIOS 3 is an auto recovery tool that allows you to restore the BIOS file when it fails or gets corrupted during the updating process. You can update a corrupted BIOS file using a USB flash drive that contains the updated BIOS file.



Prepare a USB flash drive containing the updated motherboard BIOS before using this utility.



When downloading or updating the BIOS file, rename it as **P11CM4L.CAP** for this motherboard.

Recovering the BIOS from a USB flash drive

To recover the BIOS from a USB flash drive:

1. Insert the USB flash drive with the original or updated BIOS file to one USB port on the system.
2. The utility will automatically recover the BIOS. It resets the system when the BIOS recovery finished.



DO NOT shut down or reset the system while recovering the BIOS! Doing so would cause system boot failure!



The recovered BIOS may not be the latest BIOS version for this motherboard. Visit the ASUS website at www.asus.com to download the latest BIOS file.

5.1.2 ASUS EzFlash Utility

The ASUS EzFlash Utility feature allows you to update the BIOS using a USB flash disk without having to use a DOS-based utility.



Download the latest BIOS from the ASUS website at www.asus.com before using this utility.



The succeeding BIOS screens are for reference only. The actual BIOS screen displays may not be the same as shown.

To update the BIOS using EzFlash Utility:

1. Insert the USB flash disk that contains the latest BIOS file to the USB port.
2. Enter the BIOS setup program. Go to the **Tool** menu to select **Start EzFlash** and press <Enter> to enable it.

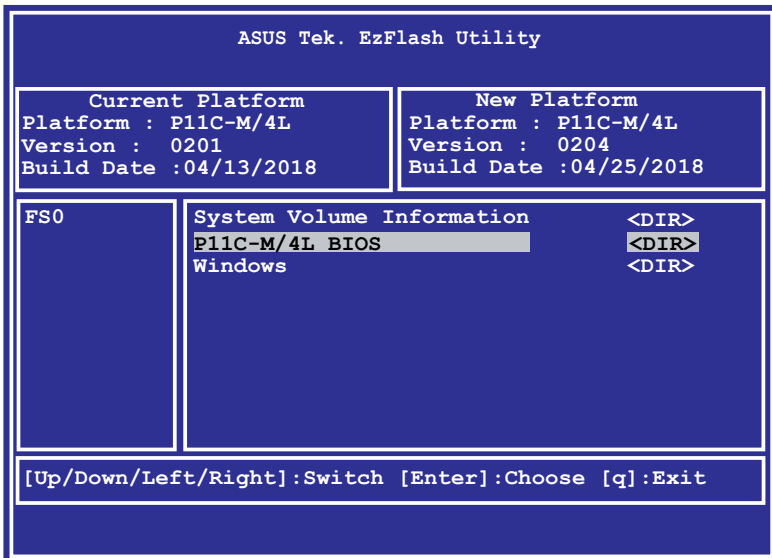

3. Press <Tab> to switch to the **Drive** field.
4. Press the Up/Down arrow keys to find the USB flash disk that contains the latest BIOS then press <Enter>.
5. Press <Tab> to switch to the **Folder Info** field.
6. Press the Up/Down arrow keys to find the BIOS file then press <Enter>.
7. Reboot the system when the update process is done.



-
- This function can support devices such as a USB flash disk with FAT 32/16 format and single partition only.
 - DO NOT shut down or reset the system while updating the BIOS to prevent system boot failure!
-



Ensure to load the BIOS default settings to ensure system compatibility and stability. Press <F5> and select **Yes** to load the BIOS default settings.

5.1.3 BUPDATER utility



The succeeding BIOS screens are for reference only. The actual BIOS screen displays may not be the same as shown.

The BUPDATER utility allows you to update the BIOS file in DOS environment using a bootable USB flash disk drive with the updated BIOS file.

Updating the BIOS file

To update the BIOS file using the BUPDATER utility:

1. Visit the ASUS website at www.asus.com and download the latest BIOS file for the motherboard. Save the BIOS file to a bootable USB flash disk drive.
2. Download the BUPDATER utility (BUPDATER.exe) from the ASUS support website at www.asus.com/support to the bootable USB flash disk drive you created earlier.
3. Boot the system in DOS mode, then at the prompt, type:

```
BUPDATER /i [filename] .CAP
```

where [filename] is the latest or the original BIOS file on the bootable USB flash disk drive, then press <Enter>.

```
A:\>BUPDATER /i[file name]CAP
```

5.2 BIOS setup program

This motherboard supports a programmable firmware chip that you can update using the provided utility described in section **5.1 Managing and updating your BIOS**.

Use the BIOS Setup program when you are installing a motherboard, reconfiguring your system, or prompted to “Run Setup.” This section explains how to configure your system using this utility.

Even if you are not prompted to use the Setup program, you can change the configuration of your computer in the future. For example, you can enable the security password feature or change the power management settings. This requires you to reconfigure your system using the BIOS Setup program so that the computer can recognize these changes and record them in the NVRAM of the firmware chip.

The firmware chip on the motherboard stores the Setup utility. When you start up the computer, the system provides you with the opportunity to run this program. Press during the Power-On Self-Test (POST) to enter the Setup utility; otherwise, POST continues with its test routines.

If you wish to enter Setup after POST, restart the system by pressing <Ctrl>+<Alt>+, or by pressing the reset button on the system chassis. You can also restart by turning the system off then back on. Do this last option only if the first two failed.

The Setup program is designed to make it as easy to use as possible. Being a menu-driven program, it lets you scroll through the various sub-menus and make your selections from the available options using the navigation keys.



-
- The default BIOS settings for this motherboard apply for most conditions to ensure optimum performance. If the system becomes unstable after changing any BIOS settings, load the default settings to ensure system compatibility and stability. Press <F5> and select **Yes** to load the BIOS default settings.
 - The BIOS setup screens shown in this section are for reference purposes only, and may not exactly match what you see on your screen.
 - Visit the ASUS website (www.asus.com) to download the latest BIOS file for this motherboard.
-

5.2.1 BIOS menu screen

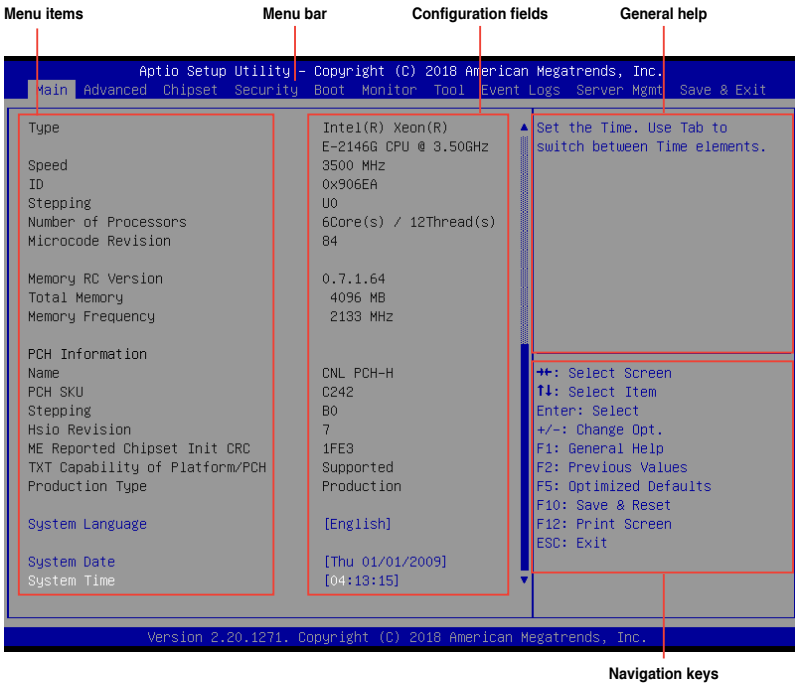

5.2.2 Menu bar

The menu bar on top of the screen has the following main items:

- Main** For changing the basic system configuration
- Advanced** For changing the advanced system settings
- Chipset** For changing the chipset settings
- Security** For changing the security settings
- Boot** For changing the system boot configuration
- Monitor** For displaying the system temperature, power status, and changing the fan settings
- Tool** For configuring options for special functions
- Event Logs** For changing the event log settings
- Server Mgmt** For changing the server mgmt settings
- Save & Exit** For selecting the save & exit options

To select an item on the menu bar, press the right or left arrow key on the keyboard until the desired item is highlighted.

5.2.3 Menu items

The highlighted item on the menu bar displays the specific items for that menu. For example, selecting Main shows the Main menu items.

The other items (Advanced, Chipset, Security, Boot,, Monitor, Tool, Event Logs, Server Mgmt, and Save & Exit) on the menu bar have their respective menu items.

5.2.4 Submenu items

A solid triangle before each item on any menu screen means that the item has a submenu. To display the submenu, select the item then press <Enter>.

5.2.5 Navigation keys

At the bottom right corner of a menu screen are the navigation keys for the BIOS setup program. Use the navigation keys to select items in the menu and change the settings.

5.2.6 General help

At the top right corner of the menu screen is a brief description of the selected item.

5.2.7 Configuration fields

These fields show the values for the menu items. If an item is user-configurable, you can change the value of the field opposite the item. You cannot select an item that is not user-configurable.

A configurable field is enclosed in brackets, and is highlighted when selected. To change the value of a field, select it and press <Enter> to display a list of options.

5.2.8 Pop-up window

Select a menu item and press <Enter> to display a pop-up window with the configuration options for that item.

5.2.9 Scroll bar

A scroll bar appears on the right side of a menu screen when there are items that do not fit on the screen. Press the Up/Down arrow keys or <Page Up> / <Page Down> keys to display the other items on the screen.

5.3 Main menu

When you enter the BIOS Setup program, the Main menu screen appears. The Main menu provides you an overview of the basic system information, and allows you to set the system date, time, and language.



Navigate to the second page of the screen to see the rest of items in this menu by pressing the Up or Down arrow keys.



To quickly go to the last item of the second page, press the **Page Down** button. Press the **Page Up** button to go back to the first item in the first page.

System Date [Day MM/DD/YYYY]

Allows you to set the system date.

System Time [HH:MM:SS]

Allows you to set the system time.

5.4 Advanced menu

The Advanced menu items allow you to change the settings for the CPU and other system devices.



Take caution when changing the settings of the Advanced menu items. Incorrect field values can cause the system to malfunction.

Aptio Setup Utility - Copyright (C) 2018 American Megatrends, Inc.

Main Advanced Chipset Security Boot Monitor Tool Event Logs Server Mgmt Save & Exit

- ▶ CPU Configuration
- ▶ Power & Performance
- ▶ Server ME Configuration
- ▶ Trusted Computing
- ▶ APM Configuration
- ▶ Runtime Error Logging Settings
- ▶ Onboard LAN Configuration
- ▶ Serial Port Console Redirection
- ▶ Intel TXT Information
- ▶ PCI Subsystem Settings
- ▶ USB Configuration
- ▶ Network Stack Configuration
- ▶ CSM Configuration
- ▶ NVMe Configuration
- ▶ WHEA Configuration
- ▶ Tls Auth Configuration
- ▶ iSCSI Configuration

CPU Configuration Parameters

++: Select Screen
F1: Select Item
Enter: Select
+/-: Change Opt.
F1: General Help
F2: Previous Values
F5: Optimized Defaults
F10: Save & Exit
F12: Print Screen
ESC: Exit

Version 2.19.1269. Copyright (C) 2018 American Megatrends, Inc.

5.4.1 CPU Configuration

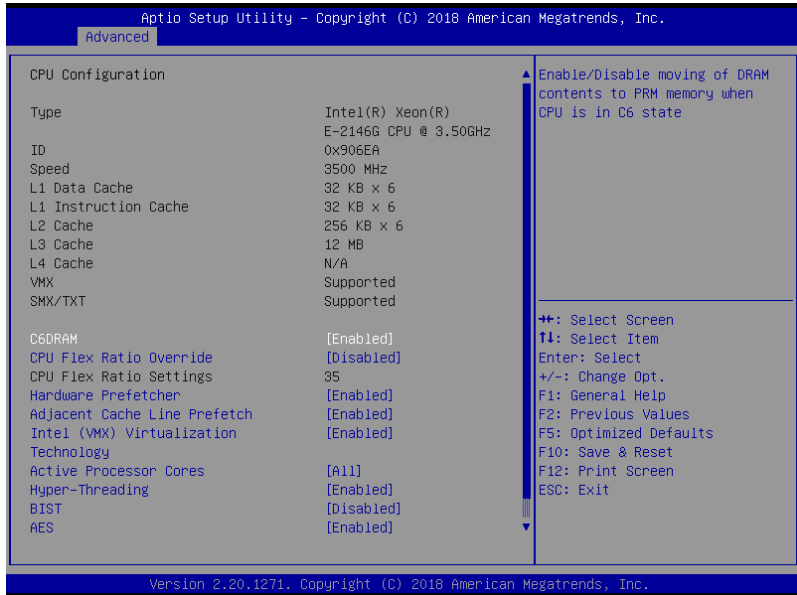

The screenshot shows the Aptio Setup Utility interface for CPU Configuration. The title bar reads "Aptio Setup Utility - Copyright (C) 2018 American Megatrends, Inc." and the current screen is "Advanced". The CPU Configuration section lists various hardware and software settings. On the right side, there is a help menu with navigation instructions.

Setting	Value
Type	Intel(R) Xeon(R) E-2146G CPU @ 3.50GHz
ID	0x906EA
Speed	3500 MHz
L1 Data Cache	32 KB x 6
L1 Instruction Cache	32 KB x 6
L2 Cache	256 KB x 6
L3 Cache	12 MB
L4 Cache	N/A
VMX	Supported
SMX/TXT	Supported
C6DRAM	[Enabled]
CPU Flex Ratio Override	[Disabled]
CPU Flex Ratio Settings	35
Hardware Prefetcher	[Enabled]
Adjacent Cache Line Prefetch	[Enabled]
Intel (VMX) Virtualization Technology	[Enabled]
Active Processor Cores	[All]
Hyper-Threading	[Enabled]
BIST	[Disabled]
AES	[Enabled]

Help Menu:

- +/: Select Screen
- F1: Select Item
- Enter: Select
- +/-: Change Opt.
- F1: General Help
- F2: Previous Values
- F5: Optimized Defaults
- F10: Save & Reset
- F12: Print Screen
- ESC: Exit

Version 2.20.1271. Copyright (C) 2018 American Megatrends, Inc.

C6DRAM [Enabled]

Allows you to enable or disable moving of DRAM contents to PRM memory when the CPU is in C6 state.

Configuration options: [Disabled] [Enabled]

Software Guard Extensions (SGX) [Software Controlled]

Allows you to select the behavior of Software Guard Extensions (SGX).

Configuration options: [Software Controlled] [Disabled] [Enabled]



The following items appear only when you set **Software Guard Extensions (SGX)** to **[Enabled]** or **[Software Controlled]**.

Select Owner EPOCH input type [No change in Owner EPOCHs]

Allows you to select the behavior of EPOCH input type.

Configuration options: [No change in Owner EPOCHs] [Change to New Random EPOCHs] [Manual User Defined Owner EPOCHs]

SGX Launch Control Policy [Unlocked]

Allows you to select the behavior of SGX Launch Control Policy.

Configuration options: [Intel Locked] [Unlocked] [Locked]



The following items appear only when you set **SGX Launch Control Policy** to **[Locked]**.

SGX LE Public Key Hash 0-3 [0]

Allows you to set the Bytes of the Software Guard Extensions (SGX) Launch Enclave Public Key Hash.



The following item appears only when you set **Software Guard Extensions (SGX)** to **[Enabled]**.

PRMRR Size [128MB]

Allows you to set the PRMRR Size.

Configuration options: [32MB] [64MB] [128MB]

CPU Flex Ratio Override [Disabled]

Allows you to enable or disable CPU Flex Ratio Override.

Configuration options: [Disabled] [Enabled]



The following item appears only when you set **CPU Flex Ratio Override** to **[Enabled]**.

CPU Flex Ratio Settings [35]

Allows you to set the CPU Flex Ratio.

This value must be between the Max Efficiency Ratio (LFM) and the Maximum non-turbo ratio set by the Hardware (HFW).

Hardware Prefetcher [Enabled]

This Item allows you to turn on/off the MLC streamer prefetcher.

Configuration options: [Disabled] [Enabled]

Adjacent Cache Prefetch [Enabled]

This Item allows you to turn on/off prefetching of adjacent cache lines.

Configuration options: [Disabled] [Enabled]

Intel (VMX) Virtualization Technology [Enabled]

Enable this item to allow a VMM to utilize the additional hardware capabilities provided by Vanderpool Technology.

Configuration options: [Disabled] [Enabled]

Active Processor Cores [All]

This item allows you to set the number of cores to enable in each processor package.

Configuration options: [All] [1] [2] [3] [4] [5]

Hyper-Threading [Enabled]

Enable this option of Windows XP and Linux (OS optimized for Hyper-Threading Technology).

Disable this item for other OS (OS not optimized for Hyper-Threading Technology).

Configuration options: [Disabled] [Enabled]

BIST [Disabled]

Allows you to enable or disable BIST (Built-In Self Test) on reset.

Configuration options: [Disabled] [Enabled]

AES [Enabled]

Allows you to enable or disable AES (Advanced Encryption Standard).

Configuration options: [Disabled] [Enabled]

Intel Trusted Execution Technology [Disabled]

Allows you to enable or disable utilization of additional hardware capabilities provided by Intel(R) Trusted Execution Technology. Changes require a full power cycle to take effect.

Configuration options: [Disabled] [Enabled]

5.4.2 Power & Performance

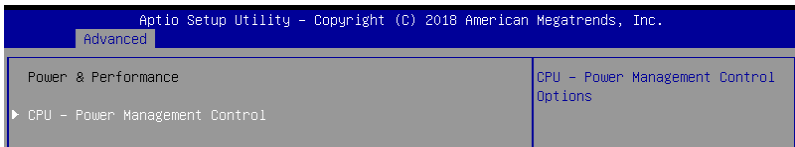

CPU - Power Management Control

Boot performance mode [Max Non-Turbo Performance]

This item allows you to select the performance state that the BIOS will set starting from reset vector.

Configuration options: [Max Battery] [Max Non-Turbo Performance] [Turbo Performance]

Intel(R) SpeedStep(tm) [Enabled]

Allows more than two frequency ranges to be supported.

Configuration options: [Disabled] [Enabled]

Race To Halt (RTH) [Enabled]

Allows you to enable or disable Race To Halt feature. RTH will dynamically increase CPU frequency in order to enter pkg C-State faster to reduce overall power. RTH is controlled through MSR 1FC bit 20.

Configuration options: [Disabled] [Enabled]

Intel(R) Speed Shift Technology [Disabled]

Allows you to enable or disable Intel(R) Speed Shift Technology support. Enabling will expose the CPPC v2 interface to allow for hardware controlled P-states.

Configuration options: [Disabled] [Enabled]

HDC Control [Enabled]

[Disabled] Disable HDC.

[Enabled] Can be enable by OS if OS native support available.

Turbo Mode [Enabled]

Allows you to enable or disable processor turbo mode if EMTTM is also enabled.

Configuration options: [Disabled] [Enabled]

C-States [Enabled]

Allows you to enable or disable CPU power management, this allows the CPU to enter C-state when not it is not 100 % utilized.

Configuration options: [Disabled] [Enabled]



The following items appears only when you set **C-States** to **[Enabled]**.

Enhanced C-States [Enabled]

Allows you to enable or disable C11E. Enable this item to allow the CPU to switch to minimum speed when all cores enter C-State.

Configuration options: [Disabled] [Enabled]

C-State Auto Demotion [C1 and C3]

This item allows you to configure the C-state auto demotion.

Configuration options: [Disabled] [C1] [C3] [C1 and C3]

C-State Un-demotion [C1 and C3]

This item allows you to configure the C-state Un-demotion.

Configuration options: [Disabled] [C1] [C3] [C1 and C3]

Package C-State Demotion [Disabled]

This item allows you to configure the Package C-State Demotion.

Configuration options: [Disabled] [Enabled]

Package C-State Un-demotion [Disabled]

This item allows you to configure the Package C-state Un-demotion.

Configuration options: [Disabled] [Enabled]

Package C-state Limit [Auto]

This item allows you to select the maximum package C-state limit setting.

Configuration options: [C0/C1] [C2] [C3] [C6] [C7] [C7S] [C8] [C9] [C10] [CPU Default] [Auto]

Thermal Monitor [Enabled]

Allows you to enable or disable Thermal Monitoring.

Configuration options: [Disabled] [Enabled]

5.4.3 Server ME Configuration

Aptio Setup Utility - Copyright (C) 2018 American Megatrends, Inc.		
Advanced		
Server ME Configuration		Selects TPM device: PTT or dTPM. PTT - Enables PTT in
Operational Firmware Version	10:5.0.3.48	SkuMgr dTPM 1.2 - Disables PTT
Backup Firmware Version	N/A	in SkuMgr Warning ! PTT/dTPM
Recovery Firmware Version	10:5.0.3.48	will be disabled and all data
ME Firmware Features	SiEn	saved on it will be lost.
	PECIProxy	
	ICC	
	MeStorageServices	
	BootGuard	
	PTT	
	PmBusProxy	
	HSIO	
	PCHDebug	
	PCHThermalSensorInit	←+: Select Screen
	DeepSx	↑↓: Select Item
	DirectMeUpdate	Enter: Select
	TelemetryHub	+/-: Change Opt.
ME Firmware Status #1	0x100F0255	F1: General Help
ME Firmware Status #2	0x8911E006	F2: Previous Values
Current State	Operational	F5: Optimized Defaults
Error Code	No Error	F10: Save & Reset
TPM Device Selection	[PTT]	F12: Print Screen
		ESC: Exit

TPM Device Selection [PTT]

Allows you to select the TPM device.

Configuration options: [PTT] [dTPM]

5.4.4 Trusted Computing

Aptio Setup Utility - Copyright (C) 2018 American Megatrends, Inc.		
Advanced		
TPM20 Device Found		Enables or Disables BIOS
Firmware Version:	402.2	support for security device.
Vendor:	INTC	O.S. will not show Security
Security Device Support	[Enable]	Device. TCG EFI protocol and
Active PCR banks	SHA-1,SHA256	INT1A interface will not be
Available PCR banks	SHA-1,SHA256	available.

Security Device Support [Enabled]

This item allows you to enable or disable Security Device Support.

Configuration options: [Disabled] [Enabled]

5.4.5 APM Configuration

Aptio Setup Utility - Copyright (C) 2018 American Megatrends, Inc.		
Advanced		
Restore AC Power Loss	[Last State]	Restore On AC Power Loss
Power On By PCI-E/PCI	[Disabled]	
Power On By RTC	[Disabled]	

Restore AC Power Loss [Last State]

When set to [Power Off], the system goes into off state after an AC power loss. When set to [Power On], the system will reboot after an AC power loss. When set to [Last State], the system goes into either off or on state, whatever the system state was before the AC power loss.

Configuration options: [Power Off] [Power On] [Last State]

Power On By PCIE/PCI [Disabled]

[Disabled] Disables the PCI or PCIE devices to generate a wake event.

[Enabled] Enables the PCI or PCIE devices to generate a wake event.

Power On By RTC [Disabled]

[Disabled] Disables RTC to generate a wake event.

[Enabled] When set to [Enabled], the items **RTC Alarm Date (Days)** and **Hour/Minute/Second** will become user-configurable with set values.

5.4.6 Runtime Error Logging Settings

Aptio Setup Utility - Copyright (C) 2018 American Megatrends, Inc.		
Advanced		
Runtime Error Logging Settings		Runtime Error Logging System Enable/Disable
Runtime Error Logging System	[Enabled]	
Enabling		

Runtime Error Logging System Enabling [Enabled]

This item allows you to enable or disable Runtime Error Logging System.

Configuration options: [Disabled] [Enabled]

5.4.7 Onboard LAN Configuration

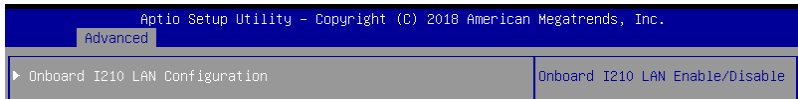

Onboard I210 LAN Configuration

Intel I210 LAN1

LAN Enable [Enabled]

Allows you to enable or disable the Intel LAN.

Configuration options: [Disabled] [Enabled]



The following item appears only when you set **LAN Enable** to [Enabled].

Intel LAN ROM Type [PXE]

Allows you to select the Intel LAN ROM type.

Configuration options: [Disabled] [PXE] [iSCSI]



Due to Intel® limitations, both Intel LAN ROM Type options should be the same when [PXE] or [iSCSI] is selected.

Intel I210 LAN2-4

LAN Enable [Enabled]

Allows you to enable or disable the Intel LAN.

Configuration options: [Disabled] [Enabled]



The following item appears only when you set Intel **LAN Enable** to [Enabled].

Intel LAN ROM Type [Disabled]

Allows you to select the Intel LAN ROM type.

Configuration options: [Disabled] [PXE] [iSCSI]



Due to Intel® limitations, both Intel LAN ROM Type options should be the same when [PXE] or [iSCSI] is selected.

5.4.8 Serial Port Console Redirection

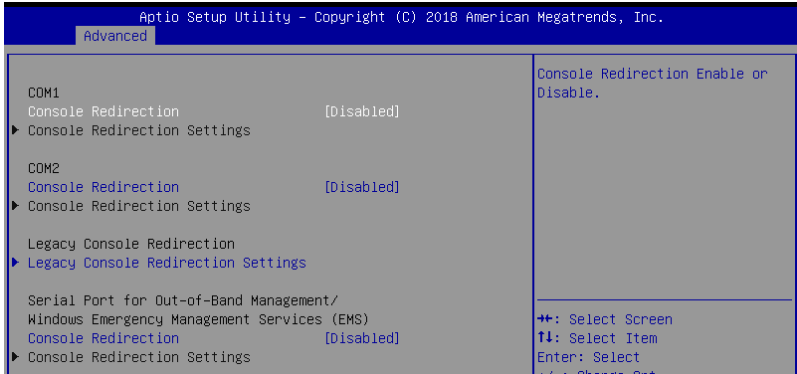

COM1/COM2

Console Redirection [Disabled]

Allows you to enable or disable the console redirection feature.

Configuration options: [Disabled] [Enabled]



The following item appears only when you set **Console Redirection** to **[Enabled]**.

Console Redirection Settings

These items become configurable only when you enable the **Console Redirection** item. The settings specify how the host computer and the remote computer (which the user is using) will exchange data. Both computers should have the same or compatible settings.

Terminal Type [VT-UTF8]

Allows you to set the terminal type.

[VT100] ASCII char set.

[VT100+] Extends VT100 to support color, function keys, etc.

[VT-UTF8] Uses UTF8 encoding to map Unicode chars onto 1 or more bytes.

[ANSI] Extended ASCII char set.

Bits per second [57600]

Selects serial port transmission speed. The speed must be matched on the other side. Long or noisy lines may require lower speeds.

Configuration options: [9600] [19200] [38400] [57600] [115200]

Data Bits [8]

Configuration options: [7] [8]

Parity [None]

A parity bit can be sent with the data bits to detect some transmission errors. [Mark] and [Space] parity do not allow for error detection.

[None]	None
[Even]	parity bit is 0 if the num of 1's in the data bits is even
[Odd]	parity bit is 0 if num of 1's in the data bits is odd
[Mark]	parity bit is always 1
[Space]	parity bit is always 0

Stop Bits [1]

Stop bits indicate the end of a serial data packet. (A start bit indicates the beginning.) The standard setting is 1 stop bit. Communication with slow devices may require more than 1 stop bit.

Configuration options: [1] [2]

Flow Control [Hardware RTS/CTS]

Flow control can prevent data loss from buffer overflow. When sending data, if the receiving buffers are full, a "stop" signal can be sent to stop the data flow. Once the buffers are empty, a "start" signal can be sent to re-start the flow. Hardware flow control uses two wires to send start/stop signals.

Configuration options: [None] [Hardware RTS/CTS]

VT -UTF8 Combo Key Support [Enabled]

This allows you to enable the VT -UTF8 Combination Key Support for ANSI/VT100 terminals.

Configuration options: [Disabled] [Enabled]

Recorder Mode [Disabled]

With this mode enabled only text will be sent. This is to capture Terminal data.

Configuration options: [Disabled] [Enabled]

Resolution 100x31 [Disabled]

This allows you to enable or disable extended terminal resolution.

Configuration options: [Disabled] [Enabled]

Putty Keypad [VT100]

This allows you to select the FunctionKey and Keypad on Putty.

Configuration options: [VT100] [LINUX] [XTERMR6] [SCO] [ESCN] [VT400]

Legacy Console Redirection Settings

Legacy Console Redirection Port [COM1]

Allows you to select a COM port to display redirection of Legacy OS and Legacy OPROM Messages.

Configuration options: [COM1] [COM2]

Resolution [80x24]

Allows you to select a the number of rows and columns in supported redirection.

Configuration options: [80x24] [80x25]

Redirect After POST [Always Enable]

Allows you to select the redirection after POST.

Configuration options: [Always Enable] [BootLoader]

Serial Port for Out-of-Band Management/Windows Emergency Management Services (EMS)

Console Redirection [Disabled]

Allows you to enable or disable the console redirection feature.
Configuration options: [Disabled] [Enabled]



The following item appears only when you set **Console Redirection** to **[Enabled]**.

Console Redirection Settings

Out-of-Band Mgmt Port [COM1]

Microsoft Windows Emergency Management Services (EMS) allow for remote management of a Windows Server OS through a serial port.
Configuration options: [COM1] [COM2]

Terminal Type [VT-UTF8]

Microsoft Windows Emergency Management Services (EMS) allow for remote management of a Windows Server OS through a serial port.
Configuration options: [VT100] [VT100+] [VT-UTF8] [ANSI]

Bits per second [115200]

Microsoft Windows Emergency Management Services (EMS) allow for remote management of a Windows Server OS through a serial port.
Configuration options: [9600] [19200] [57600] [115200]

Flow Control [None]

Microsoft Windows Emergency Management Services (EMS) allow for remote management of a Windows Server OS through a serial port.
Configuration options: [None] [Hardware RTS/CTS] [Software Xon/Xoff]

5.4.9 Intel TXT Information

You may view the Intel TXT information in this menu.

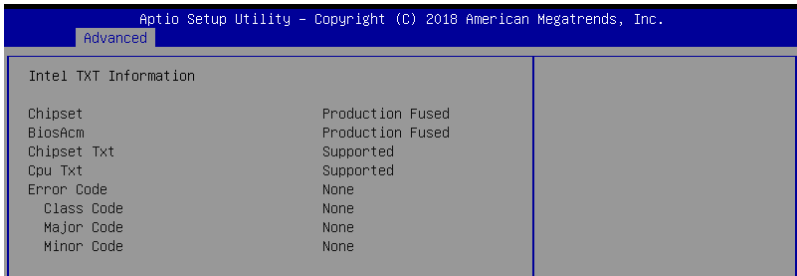

5.4.10 PCI Subsystem Settings

Allows you to configure PCI, PCI-X, and PCI Express Settings.

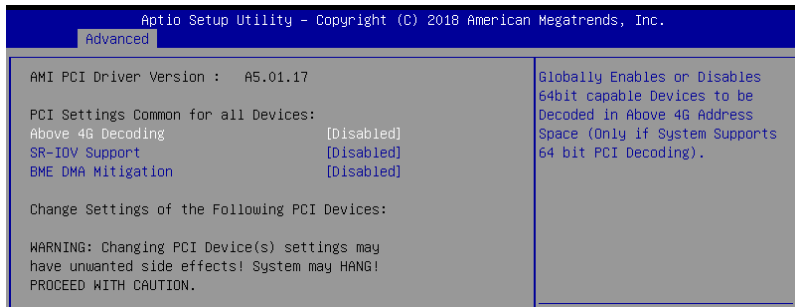

Above 4G Decoding [Disabled]

Allows you to enable or disable 64-bit capable devices to be decoded in above 4G address space. It only works if the system supports 64-bit PCI decoding.

Configuration options: [Disabled] [Enabled]

SR-IOV Support [Disabled]

This allows you to enable or disable Single Root IO Virtualization Support, if your system has SR-IOV capable PCIe Devices.

Configuration options: [Disabled] [Enabled]

BME DMA Mitigation [Disabled]

This allows you to enable or disable re-enabling Bus Master Attribute disabled during Pci enumeration for PCI Bridges after SMM locked.

Configuration options: [Disabled] [Enabled]

5.4.11 USB Configuration

Aptio Setup Utility - Copyright (C) 2018 American Megatrends, Inc.	
Advanced	
USB Configuration	Enables Legacy USB support. AUTO option disables legacy support if no USB devices are connected. DISABLE option will keep USB devices available only for EFI applications.
USB Module Version	20
USB Controllers:	
1 XHCI	
USB Devices:	
1 Drive, 1 Keyboard, 1 Mouse	
Legacy USB Support	[Enabled]
XHCI Hand-off	[Enabled]
USB Mass Storage Driver Support	[Enabled]
Port 60/64 Emulation	[Enabled]
USB hardware delays and time-outs:	
USB transfer time-out	[20 sec]
Device reset time-out	[20 sec]
Device power-up delay	[Auto]
Mass Storage Devices:	
JetFlashTranscend 4GB 8.07	[Auto]

++: Select Screen
T1: Select Item
Enter: Select
+/-: Change Opt.
F1: General Help
F2: Previous Values
F5: Optimized Defaults
F10: Save & Reset
F12: Print Screen

Legacy USB Support [Enabled]

[Disabled] The USB devices can be used only for the BIOS setup program. It cannot be recognized in boot devices list.

[Enabled] Enables the support for USB devices on legacy operating systems (OS).

[Auto] Allows the system to detect the presence of USB devices at startup. If detected, the USB controller legacy mode is enabled. If no USB device is detected, the legacy USB support is disabled.

XHCI Hand-off [Enabled]

Allows you to enable or disable workaround for OS(s) without XHCI hand-off support.
Configuration options: [Disabled] [Enabled]

USB Mass Storage Driver Support [Enabled]

Allows you to enable or disable USB Mass Storage driver support.
Configuration options: [Disabled] [Enabled]

Port 60/64 Emulation [Enabled]

Allows you to enable or disable Port 60/64 Emulation.
Configuration options: [Disabled] [Enabled]

USB hardware delays and time-outs

USB transfer time-out [20 sec]

Allows you to set the USB transfer time-out value.
Configuration options: [1 sec] [5 sec] [10 sec] [20 sec]

Device reset time-out [20 sec]

Allows you to set the device reset time-out value.
Configuration options: [10 sec] [20 sec] [30 sec] [40 sec]

Device power-up delay [Auto]

Allows you to set the maximum time the device takes before the device reports itself to the host controller properly.

Configuration options: [Auto] [Manual]



The following item appears only when you set **Device power-up delay** to **[Manual]**.

Device power-up delay in seconds [5]

Allows you to set the device power-up delay in seconds. Use the <+> or <-> to adjust the value. The values range from 1 to 40.

Mass Storage Devices

Allows you to select the mass storage device emulation type for devices connected.

Configuration options: [Auto] [Floppy] [Forced FDD] [Hard Disk] [CD-ROM]

5.4.12 Network Stack Configuration

Allows you to configure the network stack configuration.

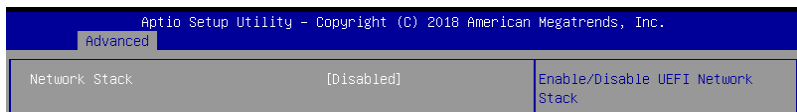

Network Stack [Disabled]

Allows you to enable or disable UEFI Network Stack.

Configuration options: [Disabled] [Enabled]



The following items appear only when you set **Network Stack** to **[Enabled]**.

Ipv4 PXE Support [Disabled]

Enables or disables the Ipv4 PXE Boot Support. If disabled, Ipv4 PXE boot option will not be created.

Configuration options: [Disabled] [Enabled]

Ipv4 HTTP Support [Disabled]

Enables or disables the Ipv4 HTTP Boot Support. If disabled, Ipv4 PXE boot option will not be created.

Configuration options: [Disabled] [Enabled]

Ipv6 PXE Support [Disabled]

Enables or disables the Ipv6 PXE Boot Support. If disabled, Ipv6 PXE boot option will not be created.

Configuration options: [Disabled] [Enabled]

Ipv6 HTTP Support [Disabled]

Enables or disables the Ipv6 HTTP Boot Support. If disabled, Ipv6 PXE boot option will not be created.

Configuration options: [Disabled] [Enabled]

IPSEC Certificate [Enabled]

Enables or disables support for IPSEC Certificate.
Configuration options: [Disabled] [Enabled]

PXE boot wait time [0]

Set the wait time to press ESC key to abort the PXE boot. Use the <+> or <-> to adjust the value. The values range from 0 to 5.

Media detect count [1]

Set the number of times presence of media will be checked. Use the <+> or <-> to adjust the value. The values range from 1 to 50.

5.4.13 CSM Configuration

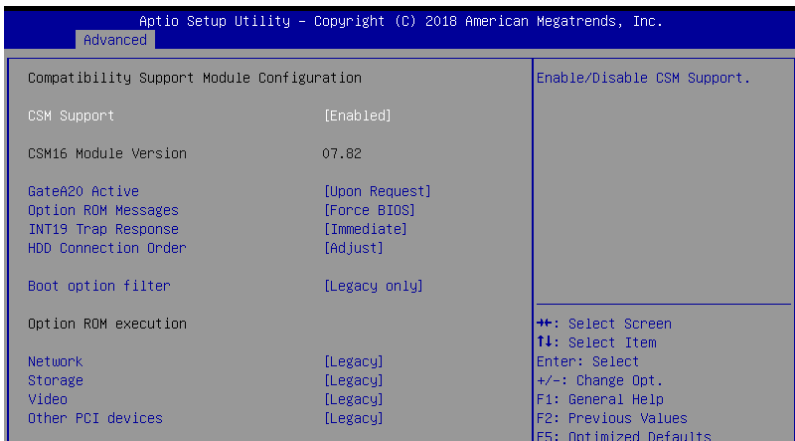

CSM Support [Enabled]

This option allows you to enable or disable CSM Support.
Configuration options: [Disabled] [Enabled]



The following items appear only when you set **CSM Support** to **[Enabled]**.

GateA20 Active [Upon Request]

This allows you to set the GA20 option.

[Upon Request] GA20 can be disabled using BIOS services.

[Always] Do not allow disabling GA20; this option is useful when any RT code is executed above 1MB.

Option ROM Messages [Force BIOS]

This allows you to set the display mode for option ROM.

Configuration options: [Force BIOS] [Keep Current]

INT19 Trap Response [Immediate]

This option allows you to control the BIOS reaction on INT19 trapping by Option ROM.

[Immediate] Execute the trap right away.
[Postponed] Execute the trap during legacy boot.

HDD Connection Order [Adjust]

This option allows you to select the HDD Connection Order. Some OS require HDD handles to be adjusted.

Configuration options: [Adjust] [Keep]

Boot Option filter [Legacy only]

This option allows you to control the Legacy/UEFI ROMs priority.

Configuration options: [UEFI and Legacy] [Legacy only] [UEFI only]

Network / Storage / Video [Legacy]

This option allows you to control the execution of UEFI and Legacy PXE/ Storage/ Video OpROM.

Configuration options: [UEFI] [Legacy]

Other PCI devices [Legacy]

This item determines the OpROM execution policy for devices other than Network, Storage, or Video.

Configuration options: [UEFI] [Legacy]

5.4.14 NVMe Configuration

You may view the NVMe controller and Drive information if an NVMe device is connected.

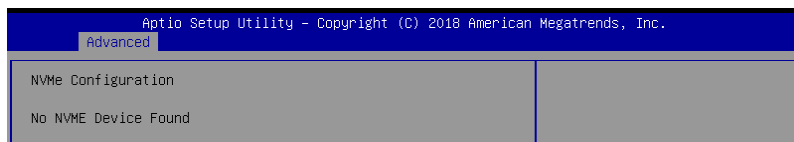

5.4.15 WHEA Configuration

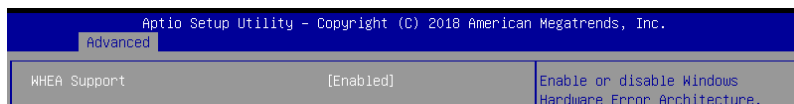

Whea Support [Enabled]

This item allows you to enable or disable the WHEA support.

Configuration options: [Disabled] [Enabled]

5.4.16 Tls Auth Configuration

Allows you to configure the Tls Auth.

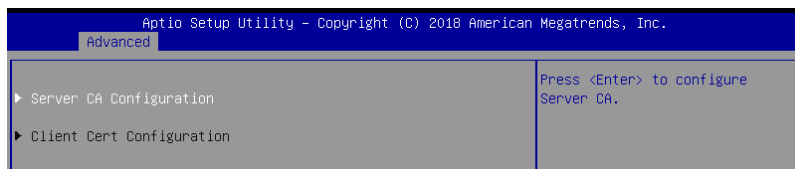

5.4.17 iSCSI Configuration

Allows you to configure the iSCSi parameters.

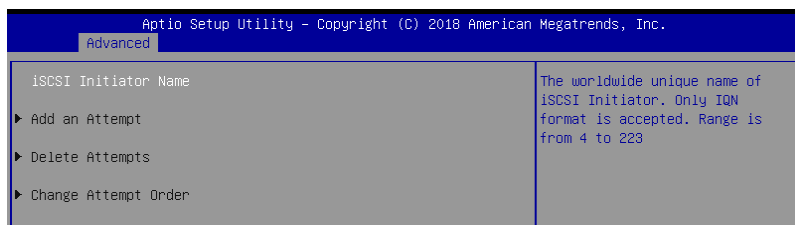

5.5 Chipset menu

The Chipset menu allows you to change the platform settings.

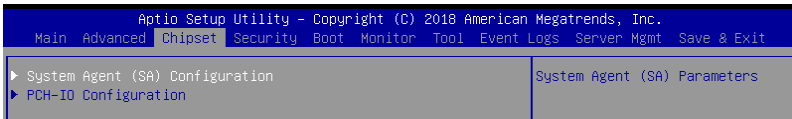

Take caution when changing the settings of the Chipset menu items. Incorrect field values can cause the system to malfunction.

5.5.1 System Agent (SA) Configuration

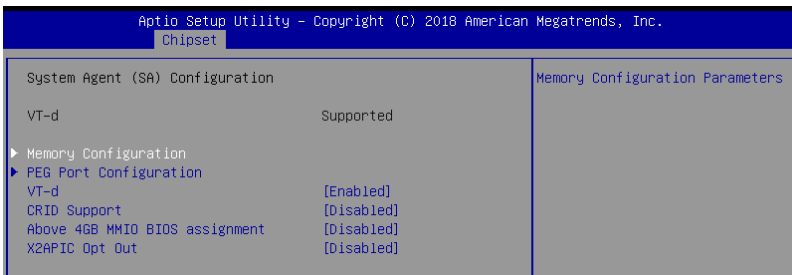

Memory Configuration

Memory Test on Warm Boot [Enabled]

Allows you to enable or disable the Base Memory Test Run on Warm Boot.
Configuration options: [Disabled] [Enabled]

Maximum Memory Frequency [Auto]

Allows you to select the maximum memory frequency setting.
Configuration options: [Auto] [2133] [2400] [2667]

ECC Support [Enabled]

Allows you to enable or disable the ECC support.
Configuration options: [Disabled] [Enabled]

Memory Scrambler [Enabled]

Allows you to enable or disable Memory Scrambler.
Configuration options: [Disabled] [Enabled]

Fast Boot [Disabled]

Allows you to enable or disable Fast Boot.
Configuration options: [Disabled] [Enabled]

PEG Port Configuration

PEG 0:1:0

Max Link Speed [Auto]

Allows you to set the Max Link Speed.
Configuration options: [Auto] [Gen1] [Gen2] [Gen3]

PEG0 Slot Power Limit Value [75]

Set the upper limit on power supplied by slot. Use the <+> or <-> to adjust the value.
The values range from 0 to 255.

PEG0 Slot Power Limit Scale [1.0x]

Allows you to select the scale for the Slot Power Limit Value.
Configuration options: [1.0x] [0.1x] [0.01x] [0.001x]

PEG0 Physical Slot Number [1]

Allows you to set the physical slot number attached to this Port. The number has to be globally unique within the chassis. Use the <+> or <-> to adjust the value. The values range from 0 to 8191.

PEG 0:1:1

Max Link Speed [Auto]

Allows you to set the Max Link Speed.
Configuration options: [Auto] [Gen1] [Gen2] [Gen3]

PEG1 Slot Power Limit Value [75]

Set the upper limit on power supplied by slot. Use the <+> or <-> to adjust the value.
The values range from 0 to 255.

PEG1 Slot Power Limit Scale [1.0x]

Allows you to select the scale for the Slot Power Limit Value.
Configuration options: [1.0x] [0.1x] [0.01x] [0.001x]

PEG1 Physical Slot Number [2]

Allows you to set the physical slot number attached to this Port. The number has to be globally unique within the chassis. Use the <+> or <-> to adjust the value. The values range from 0 to 8191.

PEG 0:1:2

Max Link Speed [Auto]

Allows you to set the Max Link Speed.
Configuration options: [Auto] [Gen1] [Gen2] [Gen3]

PEG2 Slot Power Limit Value [75]

Set the upper limit on power supplied by slot. Use the <+> or <-> to adjust the value.
The values range from 0 to 255.

PEG2 Slot Power Limit Scale [1.0x]

Allows you to select the scale for the Slot Power Limit Value.
Configuration options: [1.0x] [0.1x] [0.01x] [0.001x]

PEG2 Physical Slot Number [3]

Allows you to set the physical slot number attached to this Port. The number has to be globally unique within the chassis. Use the <+> or <-> to adjust the value. The values range from 0 to 8191.

PEG3 Slot Power Limit Value [75]

Set the upper limit on power supplied by slot. Use the <+> or <-> to adjust the value. The values range from 0 to 255.

PEG3 Slot Power Limit Scale [1.0x]

Allows you to select the scale for the Slot Power Limit Value.

Configuration options: [1.0x] [0.1x] [0.01x] [0.001x]

PEG3 Physical Slot Number [3]

Allows you to set the physical slot number attached to this Port. The number has to be globally unique within the chassis. Use the <+> or <-> to adjust the value. The values range from 0 to 8191.

VT-d [Enabled]

Allows you to enable or disable VT-d capability.

Configuration options: [Disabled] [Enabled]

CRID Support [Disabled]

Allows you to enable or disable CRID control for Intel SIPP.

Configuration options: [Disabled] [Enabled]

Above 4GB MMIO BIOS Assignment [Disabled]

Allows you to enable or disable above 4 GB memory mapped IO BIOS assignment. This is enabled automatically if the aperture size is set to 2048MB.

Configuration options: [Disabled] [Enabled]



The following item is configurable only when you set **VT-d** to **[Enabled]**.

X2APIC Opt Out [Disabled]

Allows you to enable or disable X2APIC Opt Out.

Configuration options: [Disabled] [Enabled]

5.5.2 PCH-IO Configuration



PCI Express Configuration

PCI Express Clock Gating [Enabled]

Allows you to enable or disable PCI Express clock gating for each root port.

Configuration options: [Disabled] [Enabled]

DMI Link ASPM Control [Auto]

Allows you to enable or disable control of active state power management of DMI link.
Configuration options: [Disabled] [L0s] [L1] [L0sL1] [Auto]

Port8xh Decode [Disabled]

Allows you to enable or PCI express port 8xh decode.
Configuration options: [Disabled] [Enabled]



The following item appears only when you set **Port8xh Decode** to [Enabled].

Port8xh Decode Port# [0]

Select PCI Express Port8xh Decode Root Port. User to ensure port availability.

Configuration options: [0] - [23]

SATA And RSTe Configuration

SATA Controller(s) [Enabled]

Allows you to enable or disable the SATA Controller.
Configuration options: [Disabled] [Enabled]



The following items appear only when you set **SATA Controller(s)** to [Enabled].

SATA Mode Selection [AHCI]

Allows you to select the SATA controllers operation.
Configuration options: [AHCI] [RAID]

Serial ATA Port 1-6

Port 1-6 [Enabled]

Allows you to enable or disable the SATA port.
Configuration options: [Disabled] [Enabled]

Hot Plug [Enabled]

Allows you to enable or disable this port as hot pluggable.
Configuration options: [Disabled] [Enabled]

Spin Up Device [Disabled]

Allows you to enable or disable Spin Up Device.
Configuration options: [Disabled] [Enabled]

SATA Device Type [Hard Disk Drive]

Allows you to identify the SATA port is connected to a solid state drive or a hard disk drive

Configuration options: [Hard Disk Drive] [Solid State Drive]

5.6 Security menu

This menu allows a new password to be created or a current password to be changed. The menu also enables or disables the Secure Boot state and lets the user configure the System Mode state.

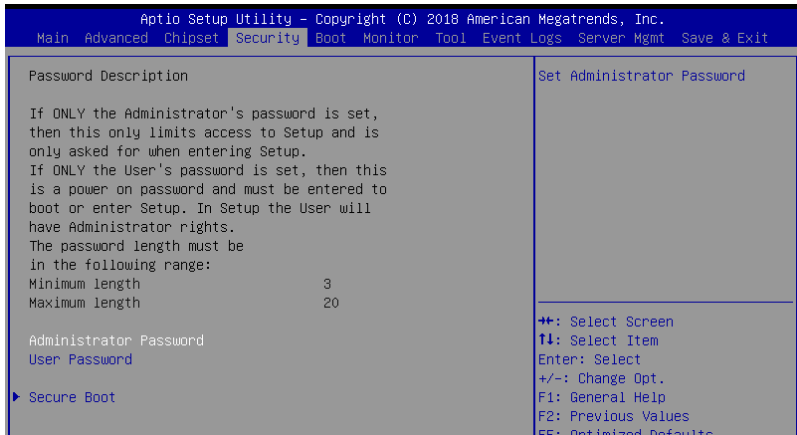

Administrator Password

To set an administrator password:

1. Select the Administrator Password item and press <Enter>.
2. From the Create New Password box, key in a password, then press <Enter>.
3. Confirm the password when prompted.

To change an administrator password:

1. Select the Administrator Password item and press <Enter>.
2. From the Enter Current Password box, key in the current password, then press <Enter>.
3. From the Create New Password box, key in a new password, then press <Enter>.
4. Confirm the password when prompted.



To clear the administrator password, follow the same steps as in changing an administrator password, but press <Enter> when prompted to create/confirm the password.

User Password

To set a user password:

1. Select the User Password item and press <Enter>.
2. From the Create New Password box, key in a password, then press <Enter>.
3. Confirm the password when prompted.

To change a user password:

1. Select the User Password item and press <Enter>.
2. From the Enter Current Password box, key in the current password, then press <Enter>.
3. From the Create New Password box, key in a new password, then press <Enter>.
4. Confirm the password when prompted.

To clear a user password:

1. Select the Clear User Password item and press <Enter>.
2. Select Yes from the Warning message window then press <Enter>.

Secure Boot

This item allows you to customize the Secure Boot settings.



Secure Boot [Disabled]

Secure Boot can be enabled if the system is running in User mode with enrolled platform Key (EPK) or if the CSM function is disabled.

Configuration options: [Disabled] [Enabled]

Secure Boot Mode [Custom]

Allows you to set the Secure Boot selector.

Configuration options: [Custom] [Standard]

Restore Factory Keys

This option will force the system to User Mode, and install factory default Secure Boot key databases.

Reset to Setup Mode

This option will delete all Secure Boot key databases from NVRAM.

Key Management

This item only appears when the item **Secure Boot Mode** is set to **[Custom]**. The Key Management item allows you to modify Secure Boot variables and set Key Management page.

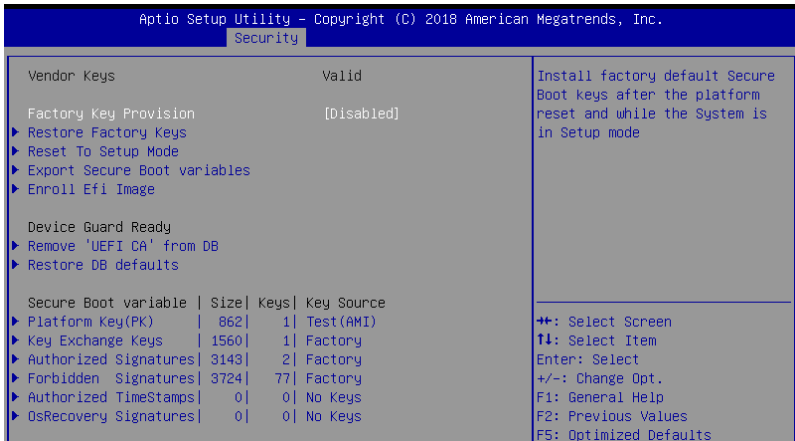

Factory Key Provision [Disabled]

Allows you to provision factory default Secure Boot keys when the system is in Setup Mode.

Configuration options: [Disabled] [Enabled]

Restore Factory keys

This item will install all Factory Default keys.

Reset to Setup Mode

This item appears only when you load the default Secure Boot keys. This item allows you to clear all default Secure Boot keys.

Export Secure Boot Variables

This item will ask you if you want to save all secure boot variables. Select Yes if you want to save all secure boot variables, otherwise select No.

Enroll Efi Image

This item will allow the image to run in Secure Boot mode.
Configuration options: [Set New] [Append]

Device Guard Ready

Remove 'UEFI CA' from DB

Remove Microsoft UEFI CA from Secure Boot DB.

Restore DB defaults

Restore DB variable to factory defaults.

Platform Key (PK)

Configuration options: [Details] [Export] [Update] [Delete]

Key Exchange Keys (KEK) / Authorized Signatures (DB) / Forbidden Signatures (DBX)

Configuration options: [Details] [Export] [Update] [Append] [Delete]

Authorized TimeStamps (DBT) / OsRecovery Signatures

Configuration options: [Update] [Append]

5.7 Boot menu

The Boot menu items allow you to change the system boot options.

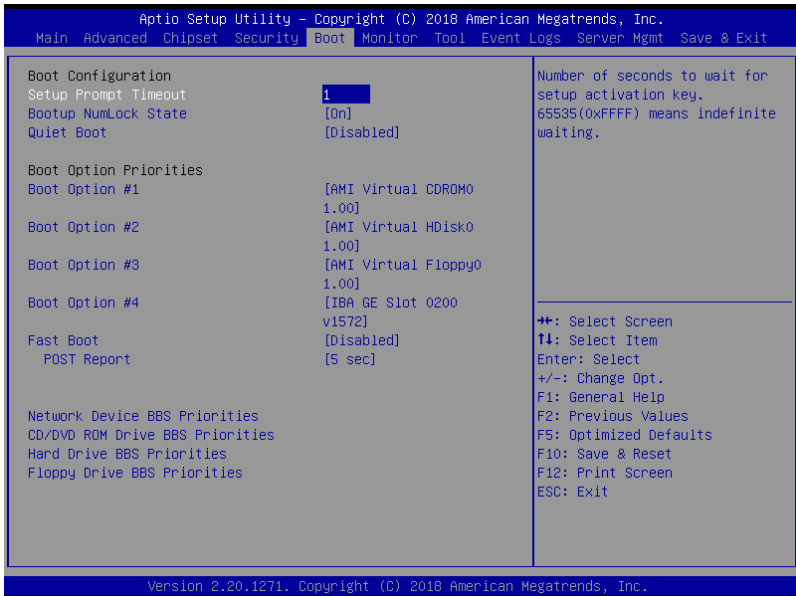

Setup Prompt Timeout [1]

Allows you to set the number of seconds that the firmware waits before initiating the original default boot selection. 65535(0xFFFF) means indefinite waiting. Use the <+> or <-> to adjust the value.

Bootup NumLock State [On]

Allows you to select the power-on state for the NumLock.

Configuration options: [Off] [On]

Quiet Boot [Disabled]

Allows you to enable or disable Quiet Boot option.

Configuration options: [Disabled] [Enabled]

Boot Option Priorities

These items specify the boot device priority sequence from the available devices. The number of device items that appears on the screen depends on the number of devices installed in the system.



- To select the boot device during system startup, press <F8> when ASUS Logo appears.
- To access Windows OS in Safe Mode, please press <F8> after POST.

Fast Boot [Disabled]

Allows you to enable or disable boot with initialization of a minimal set of devices required to launch active boot option. This has no effect for BBS boot options.

Configuration options: [Disabled] [Enabled]



The following item appears only when you set **Fast Boot** to **[Enabled]**.

Sata Support [All Sata Devices]

[Last Boot HDD Only] Only last booted HDD device will be available in POST.

[All Sata Devices] All SATA devices will be available in OS and POST.

VGA Support [EFI Driver]

[Auto] Only legacy OpRom with Legacy OS, and logo will NOT be shown during POST.

[EFI Driver] Efi driver will still be installed with EFI OS.

USB Support [Full Initial]

[Disabled] All USB devices will NOT be available until after OS boot.

[Partial Initial] USB Mass Storage and specific USB port/device will NOT be available before OS boot.

[Full Initial] All USB devices will be available in OS and POST.

PS2 Devices Support [Enabled]

If this option is disabled, PS2 devices will be skipped.

Configuration options: [Disabled] [Enabled]

Network Stack Driver Support [Disabled]

If this option is disabled, Network Stack Driver will be skipped.
Configuration options: [Disabled] [Enabled]

Redirection Support [Disabled]

If this option is disabled, Redirection function will be disabled.
Configuration options: [Disabled] [Enabled]



The following item appears only when you set **Quiet Boot** to [Disabled].

POST Report [5 sec]

Allows you to set the desired POST Report waiting time from 1 to 10 seconds.
Configuration options: [1 sec] - [10 sec] [Until Press ESC]

Network Device BBS Priorities / CD/DVD ROM Drive BBS Priorities / Hard Drive BBS Priorities / Floppy Drive BBS Priorities

These items allow you to set the booting order of the devices.

5.8 Monitor menu

This menu displays the system temperature, fan speed, and power status. You can also change the fan settings in this menu.

The screenshot shows the Aptio Setup Utility interface with the Monitor menu selected. The menu displays various system metrics and power status information. The 'FAN Speed Control' is currently set to '[Auto Mode]'. A legend on the right side of the screen provides instructions for navigating the menu.

Aptio Setup Utility - Copyright (C) 2018 American Megatrends, Inc.									
Main	Advanced	Chipset	Security	Boot	Monitor	Tool	Event Logs	Server Mgmt	Save & Exit
CPU1 Temperature	:	+83°C							Auto/Full/Manual Speed Mode
REAR_FAN1 Speed	:	N/A							
CPU_FAN1 Speed	:	2928 RPM							
FRNT_FAN1 Speed	:	N/A							
FRNT_FAN2 Speed	:	N/A							
FRNT_FAN3 Speed	:	N/A							
FRNT_FAN4 Speed	:	N/A							
+V CORE1	:	+1.128 V							
+12V	:	+12.096 V							
+5V	:	+5.120 V							
+VDDQ_AB	:	+1.224 V							
+VCCIO	:	+0.952 V							
+VCCSA	:	+1.056 V							
+5VSB	:	+5.080 V							++: Select Screen
+VCCST	:	+1.080 V							T1: Select Item
+3.3V	:	+3.280 V							Enter: Select
+3.3VSB	:	+3.328 V							+/-: Change Opt.
VBAT	:	+3.152 V							F1: General Help
									F2: Previous Values
									F5: Optimized Defaults
									F10: Save & Reset
FAN Speed Control	:	[Auto Mode]							

Fan Speed Control [Auto Mode]

Allows you to select the power-on state for the NumLock.
Configuration options: [Auto Mode] [Full Speed Mode] [Manual Speed Mode]



The following items appear only when you set **Fan Speed Control** to **[Manual Speed Mode]**.

REAR_FAN1 / CPU_FAN1 / FRNT_FAN1-3 Duty% [50]

Allows you to set the desired POST Report waiting time from 1 to 10 seconds. Use the <+> or <-> to adjust the value. The values range from 10 to 100.

5.9 Tool menu

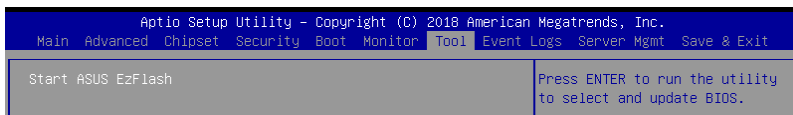

ASUS EZ Flash

Allows you to run ASUS EZ Flash BIOS ROM Utility when you press <Enter>. Refer to the ASUS EZ Flash Utility section for details.

5.10 Event Logs menu

The Event Logs menu items allow you to change the event log settings and view the system event logs.

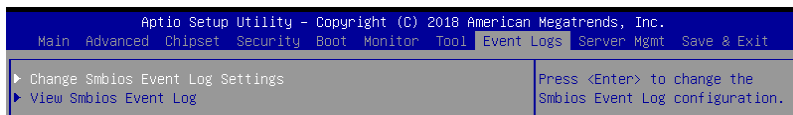

5.10.1 Change Smbios Event Log Settings

Press <Enter> to change the Smbios Event Log configuration.



All values changed here do not take effect until computer is restarted.

Enabling/Disabling Options

Smbios Event Log [Enabled]

Change this to enable or disable all features of Smbios Event Logging during boot. Configuration options: [Disabled] [Enabled]



The following items appear only when you set **Smbios Event Log** to **[Enabled]**.

Erasing Settings

Erase Event Log [No]

Choose options for erasing Smbios Event Log. Erasing is done prior to any logging activation during reset.

Configuration options: [No] [Yes, Next reset] [Yes, Every reset]

When Log is Full [Do Nothing]

Choose options for reacting to a full Smbios Event Log.
Configuration options: [Do Nothing] [Erase Immediately]

Smbios Event Log Standard Settings

Log System Boot Event [Enabled]

This option allows you to enable or disable logging System boot event.
Configuration options: [Disabled] [Enabled]

MECI [1]

This option allows you to set the number of occurrences of a duplicate event that must pass before the multiple-event counter of log entry is updated. Use the <+> or <-> to adjust the value. The values range from 1 to 255.

METW [60]

This option allows you to set the number of minutes which must pass between duplicate log entries which utilize a multiple-event counter. Use the <+> or <-> to adjust the value. The values range from 0 to 99.

Custom Options

Log EFI Status Code [Enabled]

This option allows you to enable or disable logging of the EFI Status Codes.
Configuration options: [Disabled] [Enabled]



The following item appears only when you set **Log EFI Status Code** to **[Enabled]**.

Convert EFI Status Codes to Standard Smbios Type [Disabled]

This option allows you to enable or disable converting of EFI Status Codes to Standard Smbios Type (Not all may be translated).
Configuration options: [Disabled] [Enabled]

5.10.2 View Smbios Event Log

Press <Enter> to view all smbios event logs.

5.11 Server Mgmt menu

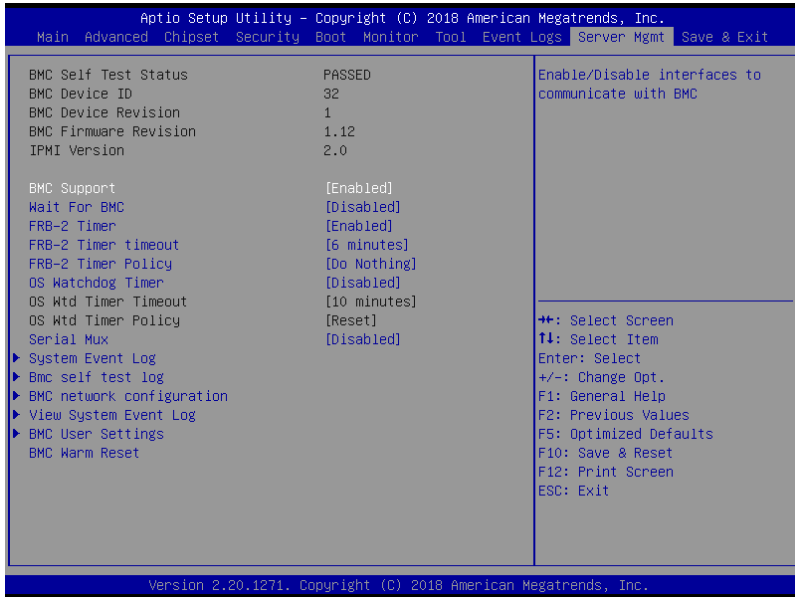

BMC Support [Enabled]

This item allows you to enable or disable interfaces to communicate with BMC.
Configuration options: [Disabled] [Enabled]



The following items appear only when **BMC Support** is set to **[Enabled]**.

Wait for BMC [Disabled]

Allows you to enable or disable wait for BMC response for specified time out.
Configuration options: [Disabled] [Enabled]

FRB-2 Timer [Enabled]

Allows you to enable or disable FRB-2 timer (POST timer).
Configuration options: [Disabled] [Enabled]

FRB-2 Timer timeout [6 minutes]

Allows you to select the FRB-2 Timer Expiration value.
Configuration options: [3 minutes] [4 minutes] [5 minutes] [6 minutes]

FRB-2 Timer Policy [Do Nothing]

Allows you to select the how the system should respond in FRB-2 Timer expires.
Configuration options: [Do Nothing] [Reset] [Power Down] [Power Cycle]

OS Watchdog Timer [Disabled]

This item allows you to start a BIOS timer which can only be shut off by Management Software after the OS loads.

Configuration options: [Disabled] [Enabled]



The following items are configurable only when **OS Watchdog Timer** is set to **[Enabled]**.

OS Wtd Timer Timeout [10 minutes]

Allows you to configure the length for the OS Boot Watchdog Timer.

Configuration options: [5 minutes] [10 minutes] [15 minutes] [20 minutes]

OS Wtd Timer Policy [Reset]

This item allows you to configure the how the system should respond if the OS Boot Watch Timer expires.

Configuration options: [Do Nothing] [Reset] [Power Down] [Power Cycle]

Serial Mux [Disabled]

Allows you to enable or disable Serial Mux configuration.

Configuration options: [Disabled] [Enabled]

BMC Warm Reset

This item allow you to perform a BMC warm reset.

5.11.1 System Event Log

Allows you to change the SEL event log configuration.

Aptio Setup Utility - Copyright (C) 2018 American Megatrends, Inc.		Server Mgmt
Enabling/Disabling Options		
SEL Components	[Enabled]	Change this to enable or disable event logging for error/progress codes during boot.
Erasing Settings		
Erase SEL	[No]	
When SEL is Full	[Do Nothing]	
Custom EFI Logging Options		
Log EFI Status Codes	[Error code]	
NOTE: All values changed here do not take effect until computer is restarted.		

Enabling/Disabling Options

SEL Components [Enabled]

Allows you to enable or disable event logging for error/progress codes during boot.

Configuration options: [No] [Yes, On next reset] [Yes, On every reset]



- The following items are configurable only when **SEL Components** is set to **[Enabled]**.
- All values changed here do not take effect until computer is restarted.

Erasing Settings

Erase SEL [No]

Allows you to choose options for erasing SEL.

Configuration options: [No] [Yes, On next reset] [Yes, On every reset]

When SEL is Full [Do Nothing]

Allows you to choose options for reactions to a full SEL.

Configuration options: [Do Nothing] [Erase Immediately]

Custom EFI Logging Options

Log EFI Status Codes [Error code]

Allows you to select which codes to log.

Configuration options: [Disabled] [Both] [Error code] [Progress code]

5.11.2 Bmc self test log

Allows you to change the SEL event log configuration.

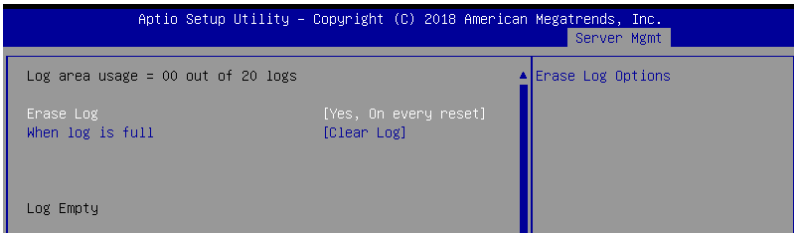

Erase Log [Yes, On every reset]

Choose options for erasing Smbios Event Log. Erasing is done prior to any logging activation during reset.

Configuration options: [No] [Yes, On every reset]

When Log is Full [Clear Log]

Allows you to choose options for reactions to a full Smbios Event Log.

Configuration options: [Clear Log] [Do not log any more]

5.11.3 BMC network configuration

The sub-items in this configuration allow you to configure the BMC network parameters.



Navigate to the second page of the screen to see the rest of items in this menu by pressing the Up or Down arrow keys.



To quickly go to the last item of the second page, press the **Page Down** button. Press the **Page Up** button to go back to the first item in the first page.

IPV4

DM_LAN1 / Shared LAN

Configuration Address source [Unspecified]

This item allows you to configure LAN channel parameters statistically or dynamically (by BIOS or BMC). Unspecified option will not modify any BMC network parameters during BIOS phase.

Configuration options: [Unspecified] [Static] [DynamicBmcDhcp] [DynamicBmcNonDhcp]

IPV6

DM_LAN1

IPV6 Support [Enabled]

Allows you to enable or disable LAN1 IPV6 Support.

Configuration options: [Disabled] [Enabled]



The following items appear only when **IPV6 Support** is set to **[Enabled]**.

Configuration Address source [Unspecified]

This item allows you to configure LAN channel parameters statistically or dynamically (by BIOS or BMC). Unspecified option will not modify any BMC network parameters during BIOS phase.

Configuration options: [Unspecified] [Static] [DynamicBmcDhcp]

Shared LAN

IPV6 Support [Enabled]

Allows you to enable or disable LAN2 IPV6 Support.

Configuration options: [Disabled] [Enabled]



The following items appear only when **IPV6 Support** is set to **[Enabled]**.

Configuration Address source [Unspecified]

This item allows you to configure LAN channel parameters statistically or dynamically (by BIOS or BMC). Unspecified option will not modify any BMC network parameters during BIOS phase.

Configuration options: [Unspecified] [Static] [DynamicBmcDhcp]

5.11.4 View System Event Log

This item allows you to view the system event log records.

5.11.5 BMC User Settings

The sub-items in this configuration allow you to add, delete, or change BMC user settings.

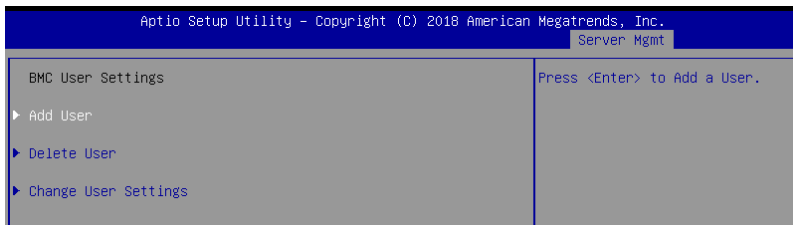

5.12 Save & Exit menu

The Exit menu items allow you to save or discard your changes to the BIOS items.

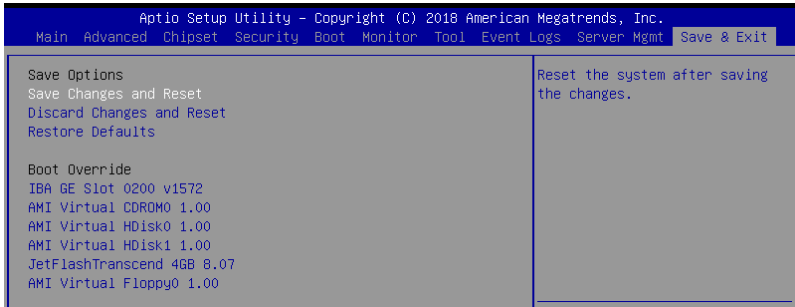

Pressing <Esc> does not immediately exit this menu. Select one of the options from this menu or <F10> from the legend bar to exit.

Save Changes and Reset

Exit System setup after saving the changes.

Discard Changes and Reset

Exit System setup without saving any changes.

Restore Defaults

Restore/load default values for all the setup options.

Boot Override

These items displays the available devices. The device items that appears on the screen depends on the number of devices installed in the system. Click an item to start booting from the selected device.

RAID Configuration

6

This chapter provides instructions for setting up, creating, and configuring RAID sets using the available utilities.

6.1 Setting up RAID

The motherboard comes with the Intel® C232 controller that supports Intel® Rapid Storage Technology enterprise Option ROM Utility with RAID 0, RAID 1, RAID 10, and RAID 5 support (for both Windows® OS and Linux).

6.1.1 RAID definitions

RAID 0 (Data striping) optimizes two identical hard disk drives to read and write data in parallel, interleaved stacks. Two hard disks perform the same work as a single drive but at a sustained data transfer rate, double that of a single disk alone, thus improving data access and storage. Use of two new identical hard disk drives is required for this setup.

RAID 1 (Data mirroring) copies and maintains an identical image of data from one drive to a second drive. If one drive fails, the disk array management software directs all applications to the surviving drive as it contains a complete copy of the data in the other drive. This RAID configuration provides data protection and increases fault tolerance to the entire system. Use two new drives or use an existing drive and a new drive for this setup. The new drive must be of the same size or larger than the existing drive.

RAID 10 is data striping and data mirroring combined without parity (redundancy data) having to be calculated and written. With the RAID 10 configuration you get all the benefits of both RAID 0 and RAID 1 configurations. Use four new hard disk drives or use an existing drive and three new drives for this setup.

RAID 5 stripes both data and parity information across three or more hard disk drives. Among the advantages of RAID 5 configuration include better HDD performance, fault tolerance, and higher storage capacity. The RAID 5 configuration is best suited for transaction processing, relational database applications, enterprise resource planning, and other business systems. Use a minimum of three identical hard disk drives for this setup.



If you want to boot the system from a hard disk drive included in a created RAID set, copy first the RAID driver from the support DVD to a floppy disk before you install an operating system to the selected hard disk drive.

6.1.2 Installing hard disk drives

The motherboard supports Serial ATA for RAID set configuration. For optimal performance, install identical drives of the same model and capacity when creating a disk array.

To install the SATA hard disks for RAID configuration:

1. Install the SATA hard disks into the drive bays following the instructions in the system user guide.
2. Connect a SATA signal cable to the signal connector at the back of each drive and to the SATA connector on the motherboard.
3. Connect a SATA power cable to the power connector on each drive.

6.1.3 Setting the RAID mode in BIOS

You must set the RAID mode in the BIOS Setup to be able to launch the RAID utilities before you can create a RAID set from the SATA hard disk drives attached to the SATA connectors supported by Intel® C232 chipset.

To do this:

1. Enter the BIOS Setup during POST.
2. Go to the **Advanced Menu > SATA Configuration**, then press <Enter>.
3. Set **SATA Mode** to [RAID].
4. Press <F10> to save your changes and exit the BIOS Setup.



Refer to **Chapter 5** for details on entering and navigating through the BIOS Setup.

6.1.4 RAID configuration utilities

Depending on the RAID connectors that you use, you can create a RAID set using the utilities embedded in each RAID controller. For example, use the **Intel® Rapid Storage Technology enterprise SATA Option ROM Utility** if you installed Serial ATA hard disk drives on the Serial ATA connectors supported by the Intel® C232 chipset.

6.2 Intel® Rapid Storage Technology enterprise SATA Option ROM Utility

The Intel® Rapid Storage Technology enterprise SATA Option ROM utility allows you to create RAID 0, RAID 1, RAID 10 (RAID 1+0), and RAID 5 set from Serial ATA hard disk drives that are connected to the Serial ATA connectors supported by the Southbridge.



Before you proceed, ensure that you have installed the Serial ATA hard disk drives, and have set the correct SATA mode in the BIOS setup. You can refer to sections **6.1.2 Installing hard disk drives** and **6.1.3 Setting the RAID mode in BIOS** for more information.

To launch the Intel® Rapid Storage Technology enterprise SATA Option ROM utility:

1. Turn on the system.
2. During POST, press <Ctrl>+<I> to display the utility main menu.

```
Intel(R) Rapid Storage Technology enterprise - SATA Option ROM - 3.6.0.1023
Copyright(C) 2003-12 Intel Corporation. All Rights Reserved.

[ MAIN MENU ]
1. Create RAID Volume
2. Delete RAID Volume
3. Reset Disks to Non-RAID
4. Exit

[ DISK/VOLUME INFORMATION ]

RAID Volumes:
None defined.

Physical Disks:
ID Drive Model Serial # Size Type/Status(Vol ID)
0 ST3300656SS HWAS0000991753TR 279.3GB Non-RAID Disk
1 ST3300656SS 37VN00009846RAJ1 279.3GB Non-RAID Disk
2 ST3300656SS 397600009846UEDY 279.3GB Non-RAID Disk
3 ST3300656SS GWC50000991756G6 279.3GB Non-RAID Disk

[{}]-Select [ESC]-Exit [ENTER]-Select Menu
```

The navigation keys at the bottom of the screen allow you to move through the menus and select the menu options.



The RAID BIOS setup screens shown in this section are for reference only and may not exactly match the items on your screen.

6.2.1 Creating a RAID set

To create a RAID set:

1. From the utility main menu, select **1. Create RAID Volume** and press <Enter>.
2. Key in a name for the RAID set and press <Enter>.

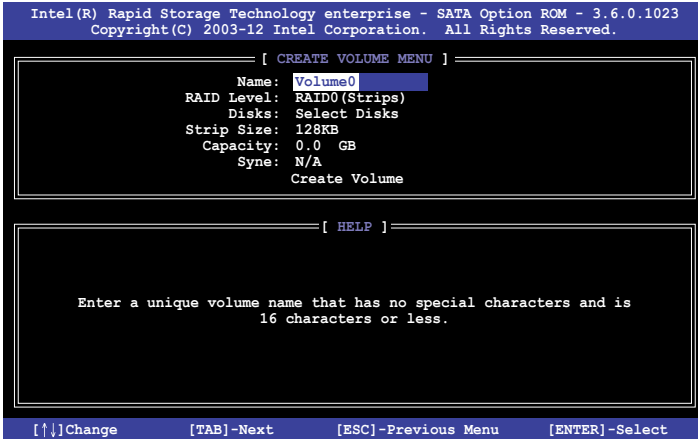

3. Press the up/down arrow keys to select a RAID Level that you wish to create then press <Enter>.
4. From the **Disks** item field, press <Enter> to select the hard disk drives that you want to include in the RAID set.

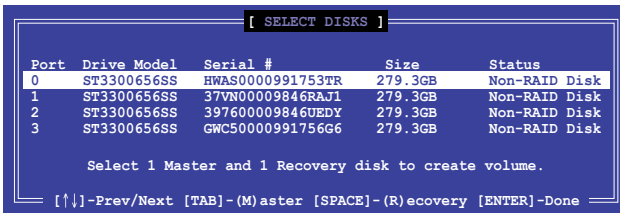

5. Use the up/down arrow keys to move the selection bar then press <Space> to select a disk. A small triangle before the Port number marks the selected drive. Press <Enter> when you are done.

6. Use the up/down arrow keys to select the stripe size for the RAID array (for RAID 0, 10 and 5 only) then press <Enter>. The available stripe size values range from 4 KB to 128 KB. The following are typical values:
RAID 0: 128KB
RAID 10: 64KB
RAID 5: 64KB



We recommend a lower stripe size for server systems, and a higher stripe size for multimedia computer systems used mainly for audio and video editing.

7. In the **Capacity** field item, key in the RAID volume capacity that you want to use and press <Enter>. The default value field indicates the maximum allowed capacity.
8. Press <Enter> to start creating the RAID volume.
9. From the following warning message, press <Y> to create the RAID volume and return to the main menu, or press <N> to go back to the **CREATE VOLUME** menu.



6.2.2 Deleting a RAID set



Take caution when deleting a RAID set. You will lose all data on the hard disk drives when you delete a RAID set.

To delete a RAID set:

1. From the utility main menu, select **2. Delete RAID Volume** and press <Enter>.
2. From the Delete Volume Menu, press the up/down arrow keys to select the RAID set you want to delete then press .

```
Intel(R) Rapid Storage Technology enterprise - SATA Option ROM - 3.6.0.1023
Copyright(C) 2003-12 Intel Corporation. All Rights Reserved.

[ DELETE VOLUME MENU ]

Name      Level      Drives  Capacity  Status  Bootable
Volume0   RAID0 (Stripe)  2       298.0GB  Normal  Yes

[ HELP ]

Deleting a volume will reset the disks to non-RAID
WARNING: ALL DISK DATA WILL BE DELETED.
(This does not apply to Recovery volumes)

[↑↓]-Select      [ESC]-Previous Menu      [DEL]-Delete Volume
```

3. Press <Y> to confirm deletion of the selected RAID set and return to the utility main menu, or press <N> to return to the **DELETE VOLUME** menu.

```
[ DELETE VOLUME VERIFICATION ]

ALL DATA IN THE VOLUME WILL BE LOST!
(This does not apply to Recovery volumes)

Are you sure you want to delete volume "Volume0"? (Y/N):
```

6.2.3 Resetting disks to Non-RAID



Take caution before you reset a RAID volume hard disk drive to non-RAID. Resetting a RAID volume hard disk drive deletes all internal RAID structure on the drive.

To reset a RAID set:

1. From the utility main menu, select **3. Reset Disks to Non-RAID** and press <Enter>.
2. Press the up/down arrow keys to select the drive(s) or disks of the RAID set you want to reset, then press <Space>. A small triangle before the Port number marks the selected drive. Press <Enter> when you are done.

```
[ RESET RAID DATA ]
Resetting RAID disk will remove its RAID structures
and revert it to a non-RAID disk.

WARNING: Resetting a disk causes all data on the disk to be lost.
(This does not apply to Recovery volumes)

Port  Drive Model  Serial #      Size      Status
0     ST3300656SS   HWAS0000991753TR  279.3GB  Member Disk
1     ST3300656SS   37VN00009846RAJL  279.3GB  Member Disk

Select the disks that should be reset.

[↑↓]-Previous/Next [SPACE]-Selects [ENTER]-Selection Complete
```

3. Press <Y> in the confirmation window to reset the drive(s) or press <N> to return to the utility main menu.

6.2.4 Exiting the Intel® Rapid Storage Technology enterprise SATA Option ROM utility

To exit the utility:

1. From the utility main menu, select **4. Exit** then press <Enter>.
2. Press <Y> to exit or press <N> to return to the utility main menu.



6.2.5 Rebuilding the RAID



This option is only for the RAID 1 set.

Rebuilding the RAID with other non-RAID disk

If any of the SATA hard disk drives included in the RAID 1 array failed, the system displays the status of the RAID volume as **"Degraded"** during POST. You can rebuild the RAID array with other installed non-RAID disks.

To rebuild the RAID with other non-RAID disk:

1. During POST, press <Ctrl>+<I> at the prompt to enter the Intel Rapid Storage Technology option ROM utility.
2. If there is a non-RAID SATA Hard Disk available, the utility will prompt you to rebuild the RAID. Press the up/down arrow keys to select the destination disk then press <Enter> to start the rebuilding process, or press <ESC> to exit.

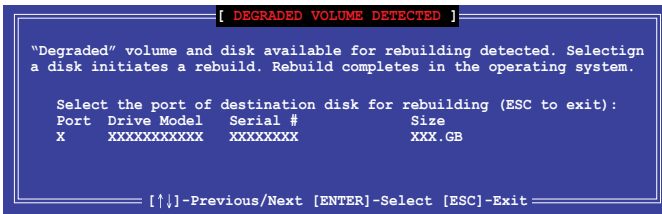

Select a destination disk with the same size as the original hard disk.

- The utility immediately starts rebuilding after the disk is selected. When done, the status of the degraded RAID volume is changed to **“Rebuild”**.

```

Intel(R) Rapid Storage Technology enterprise - SATA Option ROM - 3.6.0.1023
Copyright(C) 2003-12 Intel Corporation. All Rights Reserved.

[ MAIN MENU ]
1. Create RAID Volume
2. Delete RAID Volume
3. Reset Disks to Non-RAID
4. Exit

[ DISK/VOLUME INFORMATION ]

RAID Volumes:
ID Name Level Strip Size *Data is Encrypted
1 Volume0 RAID1(Mirror) N/A 149.0GB Rebuild Yes

Physical Devices:
Port Drive Model Serial # Size Type/Status (Vol ID)
1 ST3160812AS 9LS0F4HL 149.0GB Member Disk(0)
2 ST3160812AS 3LS0JYL8 149.0GB Member Disk(0)

Volumes with "Rebuild" status will be rebuilt within the operating system.

[↑↓]-Select [ESC]-Exit [ENTER]-Select Menu

```

- Press <Esc> to exit Intel Rapid Storage Technology and reboot the system.
- Select **Start > Programs > Intel Rapid Storage > Intel Rapid Storage Console** or click the **Intel Rapid Storage Technology** tray icon to load the Intel Rapid Storage Manager utility.
- From the **View** menu, select **Advanced Mode** to display the details of the Intel Rapid Storage Console.
- From the **Volumes view** option, select **RAID volume** to view the rebuilding status. When finished, the status is changed to **“Normal”**.

Rebuilding the RAID with a new hard disk

If any of the SATA hard disk drives included in the RAID array failed, the system displays the status of the RAID volume as **“Degraded”** during POST. You may replace the disk drive and rebuild the RAID array.

To rebuild the RAID with a new hard disk:

- Remove the failed SATA hard disk and install a new SATA hard disk of the same specification into the same SATA Port.



Select a destination disk with the same size as the original hard disk.

- Reboot the system then follow the steps in section **Rebuilding the RAID with other non-RAID disk**.

6.2.6 Setting the Boot array in the BIOS Setup Utility

You can set the boot priority sequence in the BIOS for your RAID arrays when creating multi-RAID using the Intel® Rapid Storage Technology enterprise SATA Option ROM utility.

To set the boot array in the BIOS:



Set at least one of the arrays bootable to boot from the hard disk.

1. Reboot the system and press to enter the BIOS setup utility during POST.
2. Go to the **Boot** menu and select the boot option priority.
3. Use up/down arrow keys to select the boot priority and press <Enter>. See the **Boot menu** section of Chapter 5 for more details.
4. From the **Exit** menu, select **Save Changes & Exit**, then press <Enter>.
5. When the confirmation window appears, select **Yes**, then press <Enter>.

6.3 Intel® Rapid Storage Technology enterprise (Windows)

The Intel® Rapid Storage Technology enterprise allows you to create RAID 0, RAID 1, RAID 10 (RAID 1+0), and RAID 5 set(s) from Serial ATA hard disk drives that are connected to the Serial ATA connectors supported by the Southbridge.



You need to manually install the Intel® Rapid Storage Technology enterprise utility on a Windows® operating system. Please refer to the installation instructions in **Chapter 6**.

To enter the Intel® Rapid Storage Technology enterprise utility under Windows operating system:

1. Turn on the system to windows desktop.
2. Click the **Intel® Rapid Storage Technology enterprise** icon to display the main menu.

Your storage system is configured for data protection, increased performance and optimal data storage capacity. You can create additional volumes to further optimize your storage system.

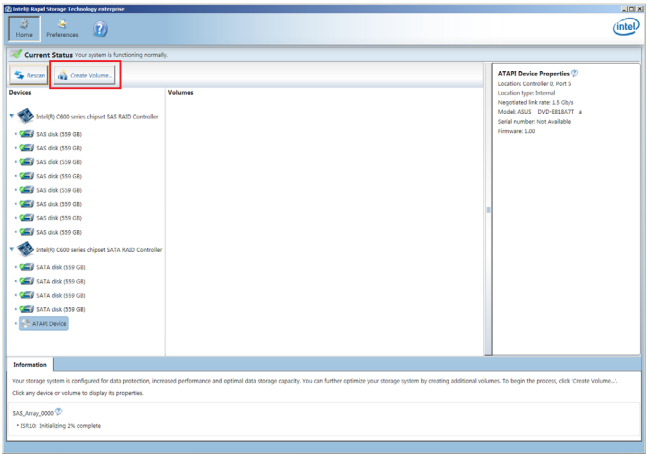

You can click **Rescan** to re-scan any attached hard disks.

6.3.1 Creating a RAID set

To create a RAID set:

1. From the utility main menu, select **Create Volume** then select volume type and click **Next**.

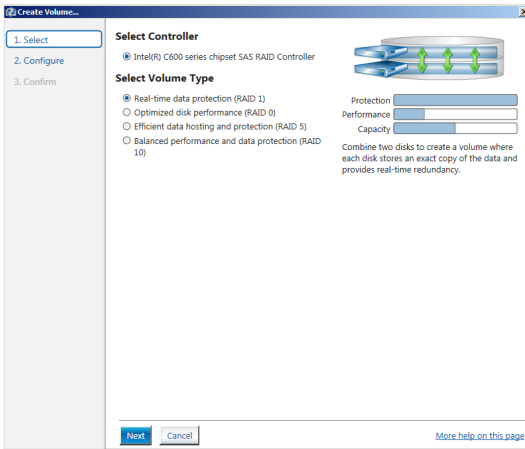

2. Key in a name for the RAID set, then select the array disks.
3. Select the **Volume Size** tab then drag the bar to set the volume size.
4. Click **Next**.

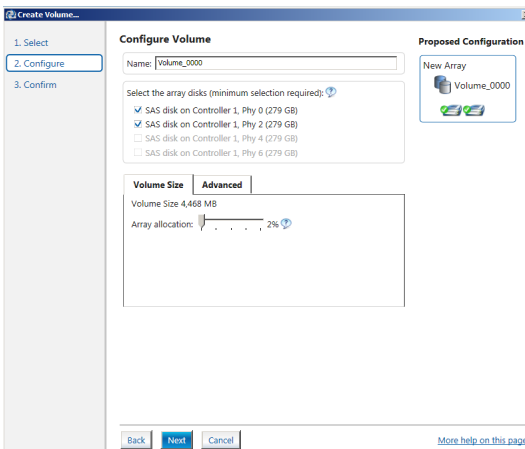

- If you do not want to keep the data on one of the selected disks, select **NO** when prompted.
- If you want to **Enable volume write-back cache** or **Initialize volume**, click **Advanced**.

5. Confirm the volume creation, then click **Create Volume** to continue.



This process could take a while depending on the number and size of the disks. You can continue using other applications during this time.

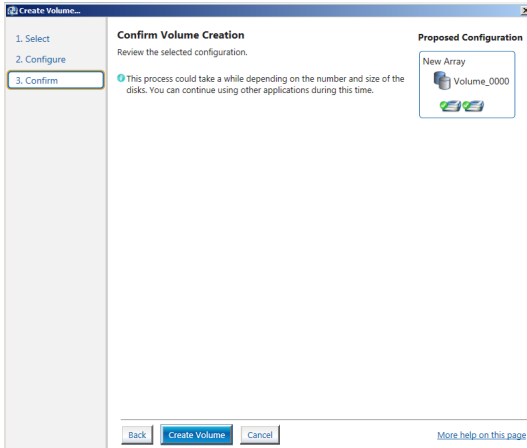

6. Wait until the process is completed, then click **OK** when prompted.

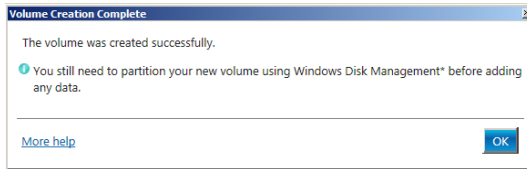

You still need to partition your new volume using Windows Disk Management before adding any data.

The created RAID set is displayed in the **Volumes** list. If you wish to change the settings, go to **Volume Properties**.

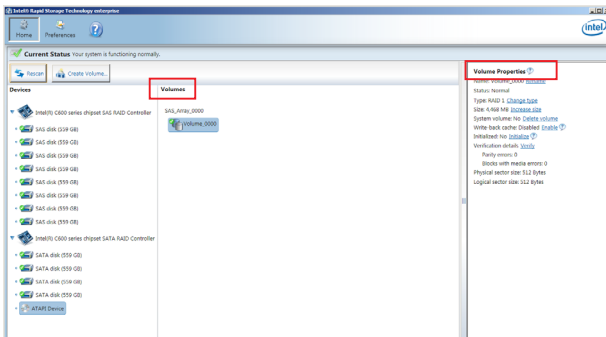

6.3.2 Changing a Volume Type

To change the volume type in **Volume Properties**:

1. Click the SATA array items you want to change in **Volumes** field.
2. From the **Volume Properties** field, select **Type: RAID 1 Change type**.

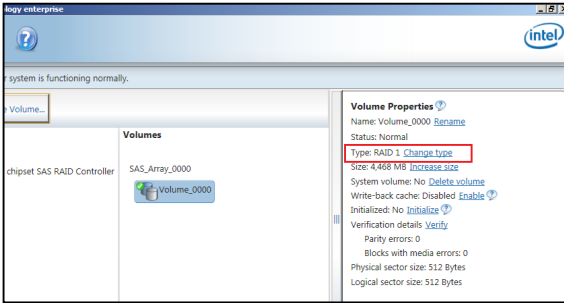

3. You can also change the **Name**, **Select the new volume type**, and **Select additional disks to include in the new volume** if needed.
4. Select the **Data stripe size** for the RAID array (for RAID 0, 10 and 5 only) and click **OK**. The available stripe size values range from 4 KB to 128 KB. The following are typical values:
RAID 0: 128KB
RAID 10: 64KB
RAID 5: 64KB

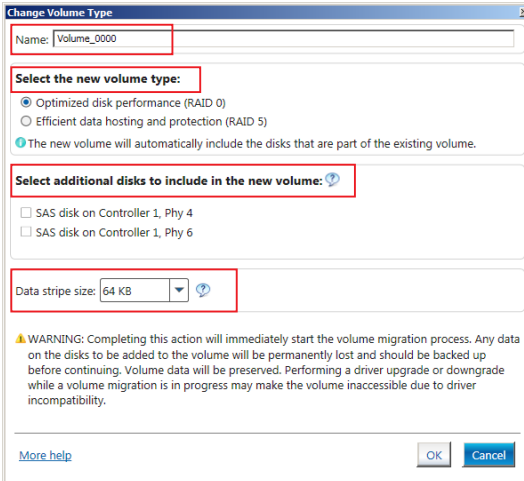

We recommend a lower stripe size for server systems, and a higher stripe size for multimedia computer systems used mainly for audio and video editing.

6.3.3 Deleting a volume



Be cautious when deleting a volume. You will lose all data on the hard disk drives. Before you proceed, ensure that you back up all your important data from your hard drives.

To delete a volume:

1. From the **Volumes** field in the utility main menu, select the volume that you want to delete.

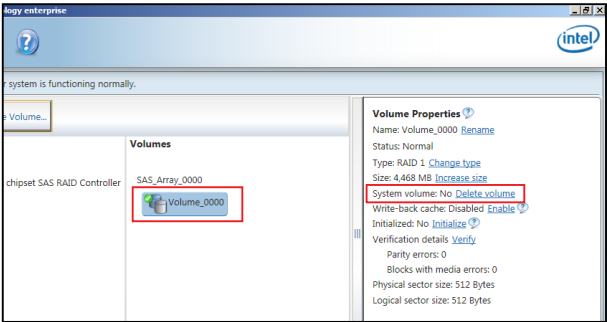

2. From the **Volume Properties** field, select **Delete volume**.
3. Click **Yes** to delete the volume and return to the utility main menu, or click **No** to return to the main menu.

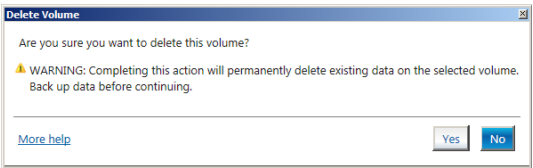

6.3.4 Preferences

System Preferences

Allow you to set to show the notification area icon and show system information, warning, or errors here.

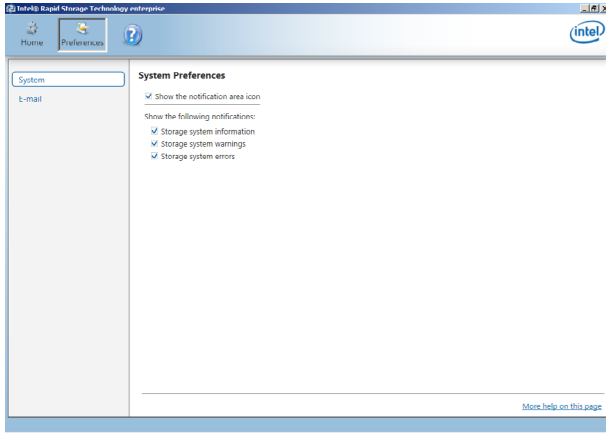

E-Mail Preferences

Allow you to set to sent e-mail of the following events:

- Storage system information
- Storage system warnings
- Storage system errors

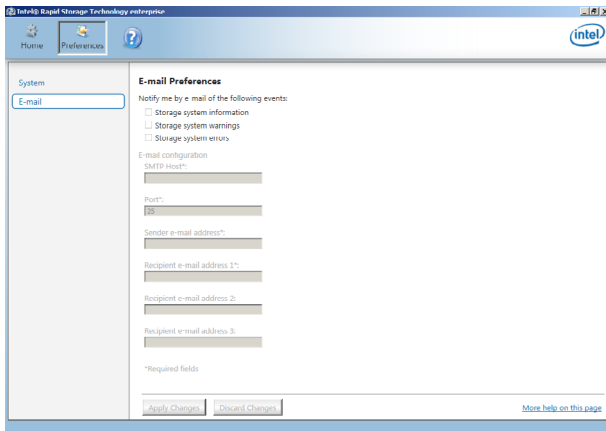

Driver Installation

7

This chapter provides the instructions for installing the necessary drivers for different system components in both Linux® and Windows® Operating Systems.

7.1 RAID driver installation

After creating the RAID sets for your server system, you are now ready to install an operating system to the independent hard disk drive or bootable array. This part provides the instructions on how to install the RAID controller drivers during OS installation.

7.1.1 Creating a USB flash drive with RAID drive

When installing Windows® Server OS, you can load the RAID driver from a USB flash drive. You can create a USB flash drive with RAID driver in Windows by copying the files from the support DVD to the USB flash drive.

To copy the RAID driver to a USB flash drive in Windows environment:

1. Place the motherboard support DVD in the optical drive.
2. Connect a USB flash drive to your system.
3. Click on the optical drive to browse the contents of the support DVD.
4. Click **Drivers > C24x INTEL RAID > Driver > Windows** and then copy the RAID driver folder to the USB flash drive.

7.1.2 Installing the RAID controller driver

During Windows® Server 2016 OS installation

To install the RAID controller driver when installing Windows® Server OS:

1. Boot the computer using the Windows® Server installation disc. Follow the onscreen instructions to start installing Windows® Server.
2. When prompted to choose a type of installation, click **Custom: Install Windows only (advanced)**.

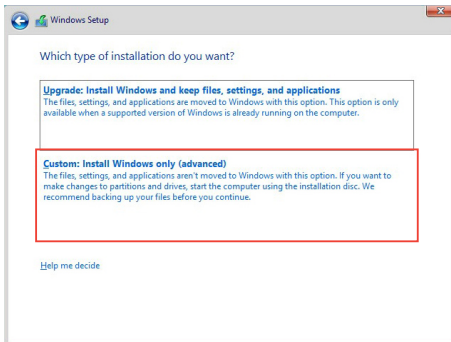

3. Click **Load Driver**.

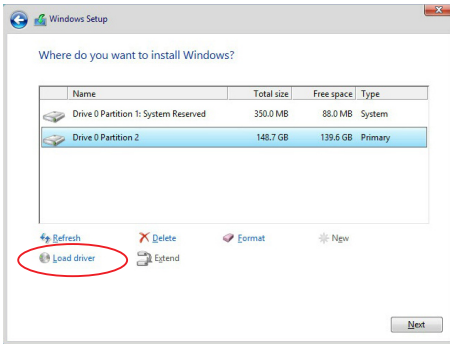

4. A message appears reminding you to insert the installation media containing the driver of the RAID controller driver (the installation media can be a CD, DVD, or USB flash drive).
- If you have only one optical drive installed in your system, eject the Windows OS installation disc and replace with the motherboard Support DVD into the optical drive.
 - Or you may connect a USB flash drive containing the RAID controller driver.

Click **Browse** to continue.

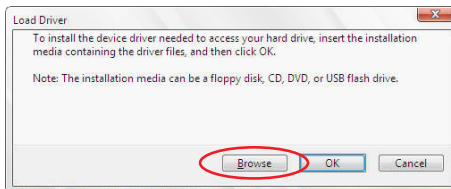

5. Locate the driver in the corresponding folder of the Support DVD or USB flash drive and then click **OK** to continue.
6. Select the RAID controller driver you need from the list and click **Next**.

7. When the system finishes loading the RAID driver,
 - Replace the motherboard Support DVD with the Windows Server installation disc.
 - Remove the USB flash drive.

Select the drive to install Windows and click **Next**.

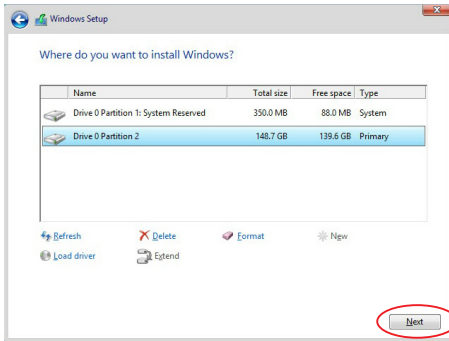

8. Setup then proceeds with the OS installation. Follow the onscreen instructions to continue.

7.2 Management applications and utilities installation

The support DVD that is bundled with your motherboard contains drivers, management applications, and utilities that you can install to maximize the features of your motherboard.



- The contents of the support DVD are subject to change at any time without notice. Visit the ASUS website (www.asus.com) for the latest updates on software and utilities.
- The support DVD is supported on Windows® Server 2016.

7.3 Running the Support DVD

When you place the support DVD into the optical drive, the DVD automatically displays the main screen if Autorun is enabled in your computer. By default, the Drivers tab is displayed.



If Autorun is NOT enabled in your computer, browse the contents of the support DVD to locate the file **Setup.exe**. Double-click the **Setup.exe** to run the support DVD.

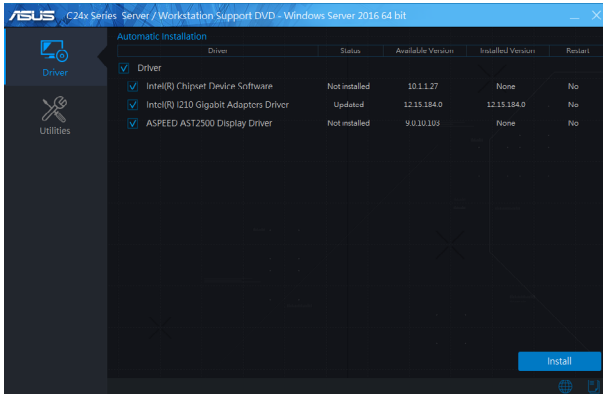

Onscreen display and content vary depending on the motherboard and chipset. The screenshots are provided for reference only.

7.4 Installing the system drivers

This section provides the instructions on how to install the system drivers. You will need to manually install the system drivers on a Windows® operating system.

To install the system drivers:

1. Restart the computer, and then log on with **Administrator** privileges.
2. Insert the support DVD into the optical drive. The support DVD automatically displays the **Driver** menu if Autorun is enabled in your computer.



If Autorun is NOT enabled in your computer, browse the contents of the support DVD to locate the file **Setup.exe**. Double-click the **Setup.exe** to run the support DVD.

3. Check the drivers that you would like to install, then select **Install**.

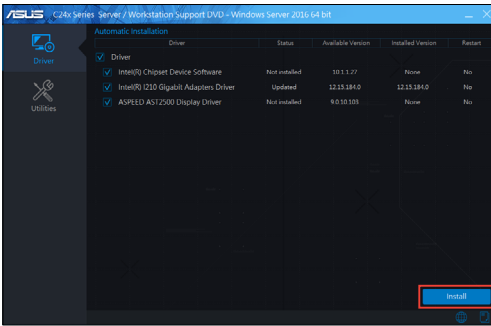

4. The installation window appears.

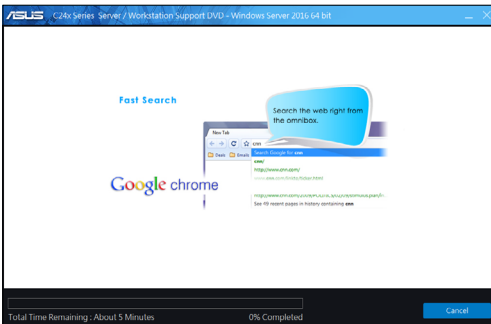

5. Follow the onscreen instructions to complete the installation.

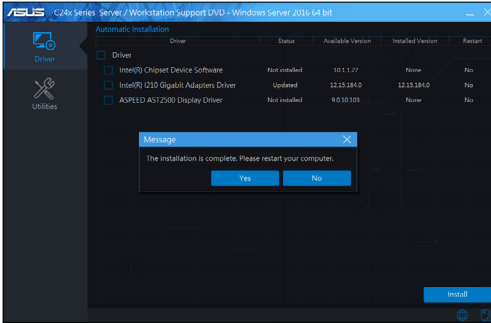

Appendix

A

P11C-M/4L block diagram

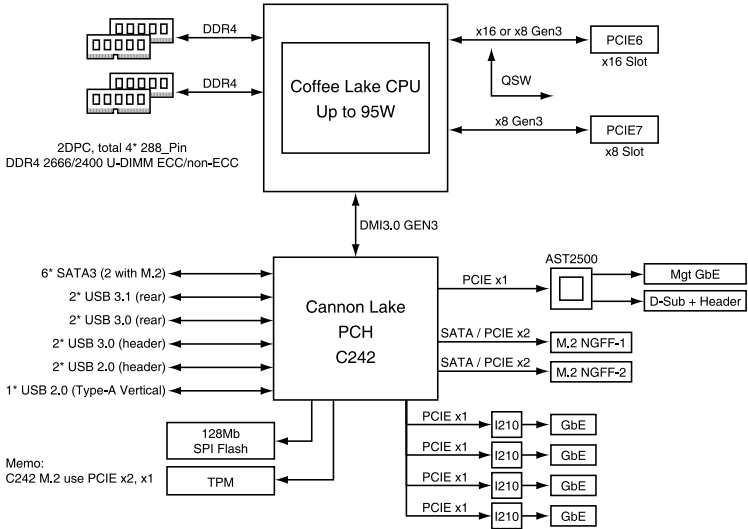

Notices

Federal Communications Commission Statement

This device complies with Part 15 of the FCC Rules. Operation is subject to the following two conditions:

- This device may not cause harmful interference.
- This device must accept any interference received including interference that may cause undesired operation.

This equipment has been tested and found to comply with the limits for a Class B digital device, pursuant to Part 15 of the FCC Rules. These limits are designed to provide reasonable protection against harmful interference in a residential installation. This equipment generates, uses and can radiate radio frequency energy and, if not installed and used in accordance with the instructions, may cause harmful interference to radio communications. However, there is no guarantee that interference will not occur in a particular installation. If this equipment does cause harmful interference to radio or television reception, which can be determined by turning the equipment off and on, the user is encouraged to try to correct the interference by one or more of the following measures:

- Reorient or relocate the receiving antenna.
- Increase the separation between the equipment and receiver.
- Connect the equipment to an outlet on a circuit different from that to which the receiver is connected.
- Consult the dealer or an experienced radio/TV technician for help.



The use of shielded cables for connection of the monitor to the graphics card is required to assure compliance with FCC regulations. Changes or modifications to this unit not expressly approved by the party responsible for compliance could void the user's authority to operate this equipment.

Compliance Statement of Innovation, Science and Economic Development Canada (ISED)

This device complies with Innovation, Science and Economic Development Canada licence exempt RSS standard(s). Operation is subject to the following two conditions: (1) this device may not cause interference, and (2) this device must accept any interference, including interference that may cause undesired operation of the device.

CAN ICES-3(B)/NMB-3(B)

Déclaration de conformité de Innovation, Sciences et Développement économique Canada (ISED)

Le présent appareil est conforme aux CNR d'Innovation, Sciences et Développement économique Canada applicables aux appareils radio exempts de licence. L'exploitation est autorisée aux deux conditions suivantes: (1) l'appareil ne doit pas produire de brouillage, et (2) l'utilisateur de l'appareil doit accepter tout brouillage radioélectrique subi, même si le brouillage est susceptible d'en compromettre le fonctionnement.

CAN ICES-3(B)/NMB-3(B)

REACH

Complying with the REACH (Registration, Evaluation, Authorisation, and Restriction of Chemicals) regulatory framework, we published the chemical substances in our products at ASUS REACH website at <http://csr.asus.com/english/REACH.htm>.



DO NOT throw the motherboard in municipal waste. This product has been designed to enable proper reuse of parts and recycling. This symbol of the crossed out wheeled bin indicates that the product (electrical and electronic equipment) should not be placed in municipal waste. Check local regulations for disposal of electronic products.



DO NOT throw the mercury-containing button cell battery in municipal waste. This symbol of the crossed out wheeled bin indicates that the battery should not be placed in municipal waste.

ASUS Recycling/Takeback Services

ASUS recycling and takeback programs come from our commitment to the highest standards for protecting our environment. We believe in providing solutions for you to be able to responsibly recycle our products, batteries, other components as well as the packaging materials. Please go to <http://csr.asus.com/english/Takeback.htm> for detailed recycling information in different regions.

Australia statement notice

From 1 January 2012 updated warranties apply to all ASUS products, consistent with the Australian Consumer Law. For the latest product warranty details please visit <https://www.asus.com/support/>. Our goods come with guarantees that cannot be excluded under the Australian Consumer Law. You are entitled to a replacement or refund for a major failure and compensation for any other reasonably foreseeable loss or damage. You are also entitled to have the goods repaired or replaced if the goods fail to be of acceptable quality and the failure does not amount to a major failure.

If you require assistance please call ASUS Customer Service 1300 2787 88 or visit us at <https://www.asus.com/support/>.

ASUS contact information

ASUSTeK COMPUTER INC.

Address 4F, No. 150, Li-Te Rd., Peitou, Taipei 112, Taiwan
Telephone +886-2-2894-3447
Fax +886-2-2890-7798
Web site <https://www.asus.com>

Technical Support

Telephone +86-21-38429911
Fax +86-21-58668722 ext: 9101
Online Support <https://www.asus.com/support/Product/ContactUs/Services/questionform/?lang=en>

ASUSTeK COMPUTER INC. (Taiwan)

Address 4F, No. 150, Li-Te Rd., Peitou, Taipei 112, Taiwan
Telephone +886-2-2894-3447
Fax +886-2-2890-7798
Web site <https://www.asus.com/tw/>

Technical Support

Telephone +886-2-2894-3447 (0800-093-456)
Online Support <https://www.asus.com/support/Product/ContactUs/Services/questionform/?lang=zh-tw>

ASUSTeK COMPUTER INC. (China)

Address No. 5077, Jindu Road, Minhang District, Shanghai, China
Telephone +86-21-5442-1616
Fax +86-21-5442-0099
Web site <https://www.asus.com.cn>

Technical Support

Telephone +86-20-2804-7506 (400-620-6655)
Online Support <https://www.asus.com/support/Product/ContactUs/Services/questionform/?lang=zh-cn>

ASUS contact information

ASUS COMPUTER INTERNATIONAL (America)

Address 48720 Kato Rd., Fremont, CA 94538, USA
Fax +1-510-608-4555
Web site <https://www.asus.com/us/>

Technical Support

Support fax +1-812-284-0883
General support +1-812-282-2787
Online support <https://www.asus.com/support/Product/ContactUs/Services/questionform/?lang=en-us>

ASUS COMPUTER GmbH (Germany and Austria)

Address Harkort Str. 21-23, 40880 Ratingen, Germany
Fax +49-2102-959911
Web site <https://www.asus.com/de/>

Technical Support

Telephone +49-1805-010923
Support Fax +49-2102-959911
Online support <https://www.asus.com/support/Product/ContactUs/Services/questionform/?lang=de-de>

ASUS Czech Service s.r.o. (Europe)

Address Na Rovince 887, 720 00 Ostrava – Hrabová,
Czech Republic
Telephone +420-596766888
Web site <https://www.asus.com/cz/>

Technical Support

Telephone +420-596-766-891
Fax +420-596-766-329
E-mail advance.rma.eu@asus.com
Online Support <https://www.asus.com/support/Product/ContactUs/Services/questionform/?lang=cs-cz>

ASUS contact information

ASUS Holland BV (The Netherlands)

Address Marconistraat 2, 7825GD EMMEN, The Netherlands
Web site <https://www.asus.com/nl/>

Technical Support

Telephone +31-(0)591-5-70292
Fax +31-(0)591-666853
E-mail advance.rma.eu@asus.com
Online Support <https://www.asus.com/support/Product/ContactUs/Services/questionform/?lang=nl-nl>

ASUS Polska Sp. z o.o. (Poland)

Address Ul. Postępu 6, 02-676 Warszawa, Poland
Web site <https://www.asus.com/pl/>

Technical Support

Telephone +48-225718033
Online Support <https://www.asus.com/support/Product/ContactUs/Services/questionform/?lang=pl-pl>

ASK-Service (Russia and CIS)

Address г.Москва, ул. Орджоникидзе, д.10, Россия
Telephone (495) 640-32-75
Web site <https://www.asus.com/ru/>

Technical Support

Telephone 008-800-100-ASUS (008-800-100-2787)
Online Support <https://www.asus.com/support/Product/ContactUs/Services/questionform/?lang=ru-ru>

