

INSTRUCTION SHEET

DWR SERIES

SECTIONAL WALL MOUNT RACK

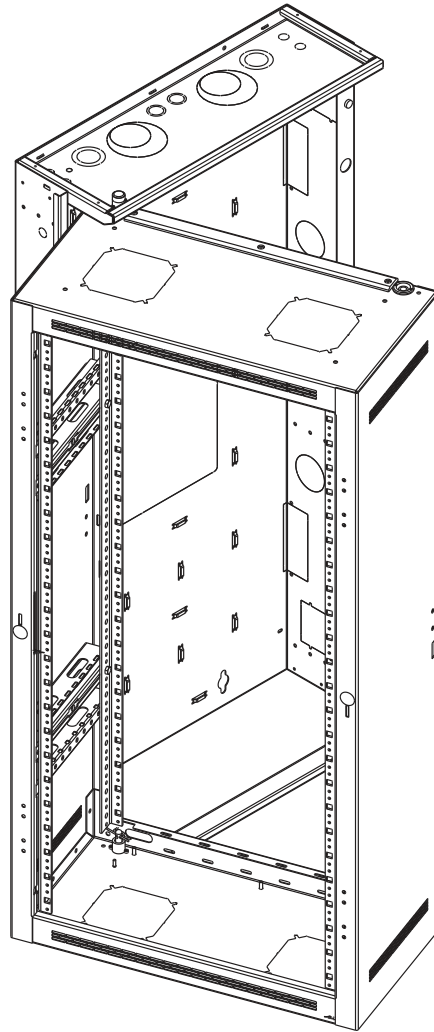

THANK YOU

Thank you for purchasing the DWR Series Sectional Wall Rack. Please read these instructions thoroughly before installing and assembling this product.

PRODUCT FEATURES

- Lever Lock™ compatible in center section and backpan for small device mounting and cable management.
- Forward compatible for 5x faster tool-free system integration.
- Tool-free quick-mount system for easy mounting of the center section to the backpan.
- Pivots 90° off the wall for access to rear connections.
- Zero clearance latch (optional) allows side-by-side mounting or interior corner mounting.



**MIDDLE
ATLANTIC**

A brand of **legrand**

100-00030

Rev D



©2026 | Legrand AV Inc. All rights reserved.

Information in this document is subject to change without notice. The AV equipment described in this document is furnished under a license agreement or nondisclosure agreement. The equipment may be used or copied only in accordance with the terms of those agreements. No part of this publication may be reproduced, stored in a retrieval system, or transmitted in any form or any means electronic or mechanical, including photocopying and recording for any purpose other than the purchaser's personal use without the written permission of Legrand AV Inc.

Middle Atlantic is a brand of Legrand AV Inc.

www.legrandav.com | Phone: (866) 977-3901 | Fax: (877) 894-6918 | Email: av.middleatlantic.techsupport@legrand.com

Visit us at www.legrandav.com for firmware updates, specifications, drawings, manuals, technical support information, and more.

Middle Atlantic is a registered trademark of Legrand AV Inc.

Legrand AV Inc is an ISO 9001 and ISO 14001 Registered Company.

All patents are protected under existing designations. Other patents pending. For more information, refer to the Patents page on the website at <https://www.legrandav.com/resources/patents>.

All other brand names or marks are used for identification purposes and are trademarks of their respective owners.

Legrand AV Inc Brands: Connectrac | C2G | Chief | Da-Lite | Luxul | Middle Atlantic | Nuvo | On-Q | Sanus | Vaddio | Vantage | Wiremold

IMPORTANT SAFETY INSTRUCTIONS - EN

- Read these instructions.
- Heed all warnings.
- Clean only with dry cloth.
- Keep these instructions.
- Follow all instructions.
- Only use attachments/accessories specified by the manufacturer.

 **DANGER HAZARDOUS VOLTAGE:** The lightning flash with the arrowhead symbol, within an equilateral triangle is intended to alert the user to the presence of uninsulated dangerous voltage within the product's enclosure that may be of sufficient magnitude to constitute a risk of electric shock to persons.

 **WARNING:** A warning alerts you to a situation that could result in serious personal injury or death.

 **CAUTION:** A caution alerts you to a situation that may result in minor personal injury or damage to the product and/or property.

 **NOTE:** A note is used to highlight procedures pertaining to the installation, operation, or maintenance of the product.

 **CAUTION:** To avoid an unstable condition, place heavier components at the bottom of the enclosure. When more than one component is placed in the enclosure, begin at the bottom of the enclosure and place equipment at the lowest available point, evenly distribute weight (horizontally) within the enclosure.

Component weight should be distributed as follows:

- 1/2 of the total component weight (at a minimum) placed in the bottom third of the cabinet.
- 1/4 of the total component weight (at a maximum) placed in the middle third of the cabinet.
- 1/4 of the total component weight (at a maximum) placed in the top third of the cabinet.

 **CAUTION:** All installation and assembly steps must be performed by qualified personnel.

 **CAUTION:** Ensure that the floor has a structural load capacity that will support the weight of the cabinet fully loaded with equipment.

 **CAUTION:** Power cord, for fans or other accessories, need to be secured to ensure that they are routed away from pinch points and moving parts.

 **CAUTION:** Do not attempt to unload or move the enclosures alone. Make sure to have sufficient amount of personnel and equipment to safely move this product.

 **CAUTION:** The following parts are not effectively bonded to the protective earth terminal: Rack rails, lace bars, Lever Lock™, shelves, baffle, blanking panels, and cable management. If any part needs to be bonded to the protective earth terminal it shall be done in accordance with current local code and regulations.

 **SEISMIC COMPLIANCE:** An engineered system is vital to achieve seismic rating requirements. A licensed professional engineer must approve the type of fasteners for the wall where the rack will be mounted. Braced according to specifications set forth by licensed architects and engineers, the Middle Atlantic Products rack/enclosure you purchased is capable of sustaining a phenomenal lateral load. Refer to the seismic data published on seismic letter on the Middle Atlantic Product website.

 **CAUTION:** Individual components mounted inside of the wall mount rack must have their own fire enclosure.

INSTRUCTIONS IMPORTANTES SUR LA SÉCURITÉ - FR

- Lire ces instructions.
- Respectez tous les avertissements.
- Nettoyer uniquement avec un chiffon sec.
- Conservez ces instructions.
- Suivez toutes les instructions.
- N'utilisez que des accessoires spécifiés par le fabricant.

 **DANGER TENSION DANGEREUSE:** Le symbole de la pointe de flèche, dans un triangle équilatéral, est destiné à alerter l'utilisateur sur la présence de tension dangereuse non isolée dans l'enceinte du produit qui peut être d'une ampleur suffisante pour constituer un risque d'électrocution.

 **AVERTISSEMENT:** Un avertissement vous avertit d'une situation pouvant entraîner des blessures graves ou la mort.

 **ATTENTION:** Une attention vous avertit d'une situation pouvant entraîner des blessures mineures ou des dommages au produit et/ou à la

REMARQUE: Une remarque est utilisée pour mettre en évidence les procédures relatives à l'installation, au fonctionnement ou à l'entretien du produit.

INSTRUCTIONS IMPORTANTES SUR LA SÉCURITÉ (A CONTINUÉ) - FR

 **ATTENTION:** Pour éviter un état instable, placez composants les plus lourds au fond de l'enceinte. Lorsque plus d'un composant est placé dans la enceinte, commencer par le bas de l'enceinte et placer l'équipement à la point le plus bas disponible, de distribuer uniformément le poids (horizontalement) dans le enceinte.

Le poids des composants devrait être réparti comme suit:

- 1/2 du poids total de la composante (au minimum) placé dans le tiers inférieur de l'armoire.
- 1/4 du poids total de la composante (au maximum) placé dans le tiers médian de l'armoire.
- 1/4 du poids total de la composante (au maximum) placé dans le tiers supérieur de l'armoire.

 **ATTENTION:** Toutes installation et de montage étapes doivent être effectuées par du personnel qualifié.

 **ATTENTION:** Veiller à ce que le sol a une capacité de charge structurelle qui supporter le poids de le cabinet entièrement chargé avec l'équipement.

 **ATTENTION:** Le cordon d'alimentation, pour les fans ou autres accessoires, doivent être fixé à veiller à ce que ils sont acheminés loin des points de pincement et des pièces mobiles.

 **ATTENTION:** Ne essayez pas de décharger ou déplacer les enceintes seul. Assurez-vous d'avoir quantité suffisante de personnel et de matériel pour déplacer ce produit en toute sécurité.

 **ATTENTION:** Les pièces suivantes ne sont pas reliées efficacement à la borne de terre de protection : rails de rack, barres de fixation, Lever Lock™, étagères, déflecteur, panneaux d'obturation et gestion des câbles. Si une pièce doit être reliée à la borne de terre de protection, cela doit être fait conformément aux codes et réglementations locaux en vigueur.

 **RESPECT SISMIQUE:** Un système d'ingénierie est essentiel pour répondre aux exigences d'évaluation sismique. Un ingénieur professionnel agréé doit approuver le type de fixations utilisées pour le montage du rack. Contreventé conformément aux spécifications établies par des architectes et ingénieurs agréés, le rack/boîtier Middle Atlantic Products que vous avez acheté est capable de supporter une charge latérale phénoménale. Reportez-vous aux données sismiques publiées sur la lettre sismique sur le site Web du produit Middle Atlantic.

 **ATTENTION:** Les composants individuels montés à l'intérieur de montage mural doivent avoir leur propre armoire à incendie.

WEIGHT RATING

Model Number	# of Mtng. Holes	Weight Rating
DWR-10-17/22	4	200 lbs. (90.7 kg) Maximum Total Rated Load
DWR-12-17/22/26/32	4	200 lbs. (90.7 kg) Maximum Total Rated Load
DWR-16-17/22	4	200 lbs. (90.7 kg) Maximum Total Rated Load
DWR-18-17/22/26/32	4	250 lbs. (113.3 kg) Maximum Total Rated Load
DWR-21-17/22	5	250 lbs. (113.3 kg) Maximum Total Rated Load
DWR-24-17/22/26/32	5	300 lbs. (136 kg) Maximum Total Rated Load
DWR-35-17/22/26	6	300 lbs. (136 kg) Maximum Total Rated Load

 **WARNING:** This product is intended for use only with the products and maximum weights indicated. Use with other products or products heavier than the maximum weights indicated may result in instability causing possible injury. Total equipment weight must not exceed the amounts listed.

 **AVERTISSEMENT:** Cette produit est conçu pour être utilisé uniquement avec les produits et les poids maximum indiqué. uniquement avec les produits et les poids maximaux indiqués. En cas d'utilisation avec d'autres produits ou des produits plus lourds que le poids maximal indiqué, le chariot peut devenir instable et causer des blessures. Le poids total de l'équipement ne doit pas dépasser les quantités indiquées.

SPEICIFICATIONS

Width: 23.4" (594 mm)

Height: 10 RU - 35 RU

Depth: 17" (432 mm), 22" (559 mm), 26" (660 mm)*, and 32" (813 mm)*

* Available for certain heights only

SUPPLIED COMPONENTS AND HARDWARE

If any pieces are missing or damaged, please report it immediately to Technical Support at av.support@legrand.com or (866) 977-3901.

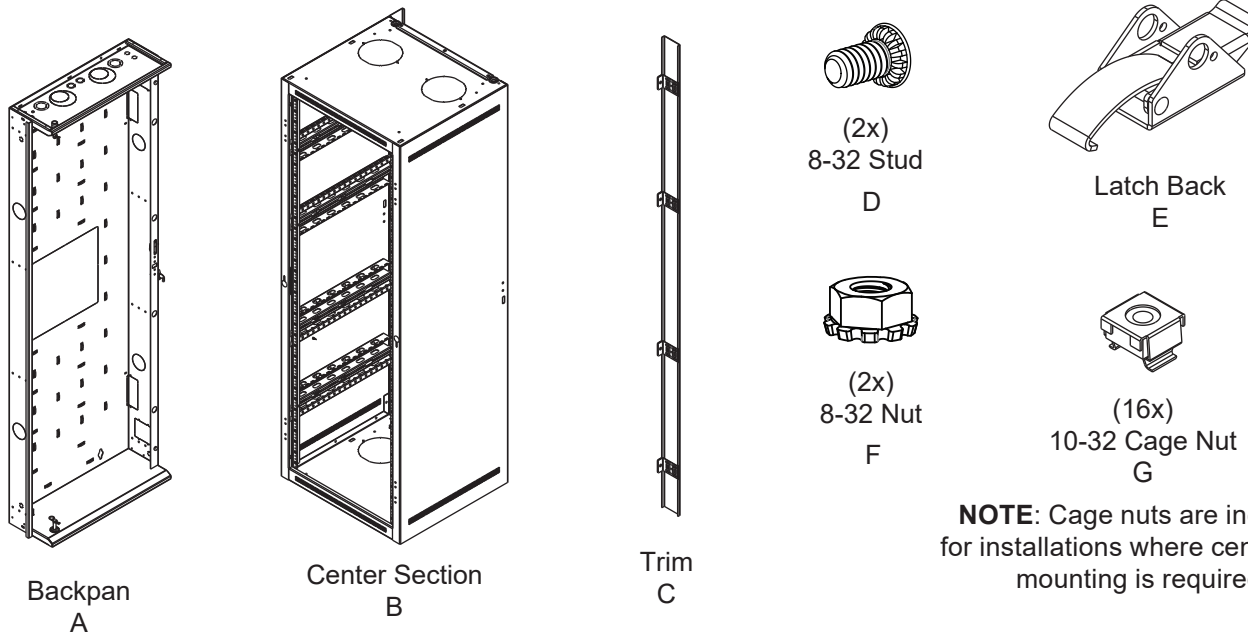

NOTE:

- To order more hardware, contact support at av.support@legrand.com or (866) 977-3901.
- Additional hardware is included that may not be required for your installation.

REQUIRED TOOLS

- Protective Eyewear
- Electric Drill
- 9/16" Socket
- 7/16" Socket
- 3/8" Socket
- Slip Joint Pliers
- #2 Flat Head Screwdriver
- #2 Phillips Screwdriver



WARNING: Use tools with caution and follow all necessary safety protocols.

AVERTISSEMENT: Utiliser des outils avec prudence et suivre tous les protocoles de sécurité nécessaires.

INSTALLING BACKPAN TO WALL



CAUTION: The backpan must be installed plumb and level for proper operation.

ATTENTION: La plaque profilée doit être aplomb et de niveau pour un fonctionnement.

NOTE: A left or right rack swing direction is contingent upon the location of the pivot bushings.

TIP: Determine the desired swing direction of the rack before mounting the backpan onto the wall.

NOTE: The backpan (A) of all DWR enclosures must be screwed to studs using the first step of this topic, except for DWRs up to 26" (660 mm) overall depth, which may be mounted to studs or a concrete wall using appropriate fasteners (not provided).

1. Use electric drill, socket, and 3/8" diameter 2" (51 mm) minimum length lag bolts, standard flat washers (lag bolts and washers not provided) to mount your backpan (A) to the wall as shown. **(FIGURE A)**

NOTE:

- Your backpan must have a minimum of 4" (102 mm) clearance on the top (to ceiling) and bottom (to floor).
- Standard flat washers must be installed directly under the lag bolt heads.
- For the number of mounting holes required, see the "Weight Rating" table on page 4. All of the mounting holes specified for your enclosure model must be used.
- Verify your electric drill torque is on the lightest setting and only increase as necessary.

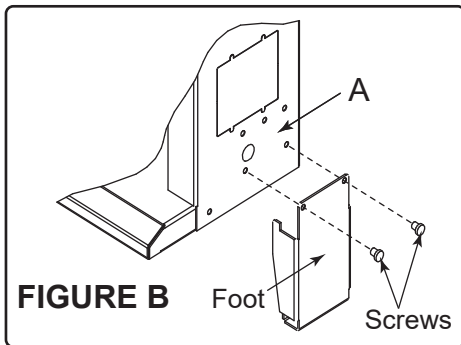
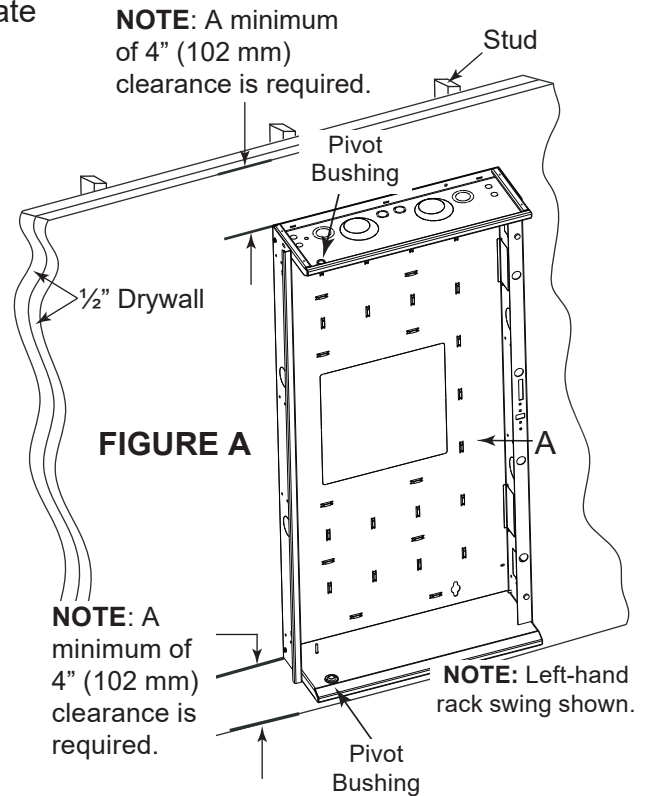

FOR 24 and 35 RU DWRs ONLY: Feet are provided and should be used when mounting in close proximity to the floor; approx. 4" (102 mm) from the floor. By doing so, the feet assist in reducing the weight of the enclosure from the mounting hardware, especially when the rack is heavily loaded.

2. Use electric drill and a #2 Phillips bit to remove the screws on both sides of the backpan bottom as shown. **(FIGURE B)**
3. With the feet in position, reattach the screws.
4. Use drill, 11/32" socket, (2x) 8-32 studs (D), and (2x) 8-32 nuts (F) to attach the latch back (E) to the backpan (A) as shown. **(FIGURE C)**

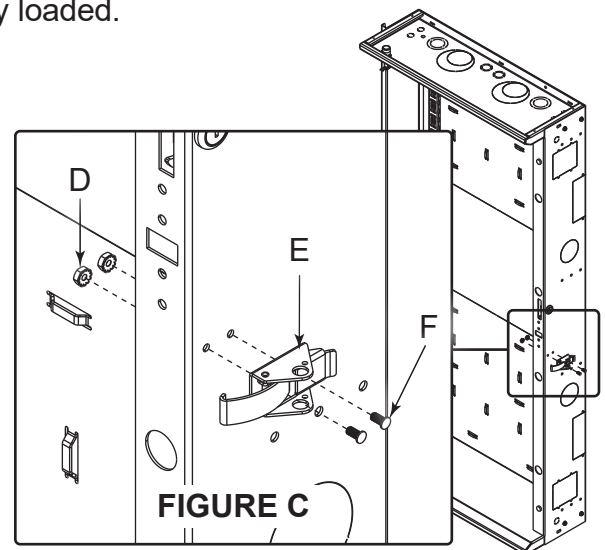

INSTALLING BACKPAN TO WALL (CONTINUED)

4. Remove security clips holding pivot pins in place in the top and bottom of the backpan (A). (**FIGURE D**)

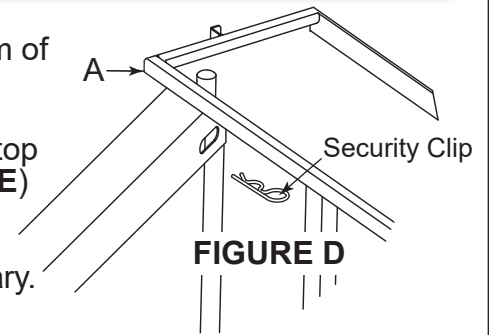

5. Use hand to loosen and remove top and bottom pivot pins. (**FIGURE E**)

NOTE: Use slip joint pliers to carefully remove the pins, if necessary.

6. Lift the center section (B) and place the bottom glide strip on the edge of the backpan (A). Position the center section to engage the lower pivot bushing on the backpan. (**FIGURE F**)

7. Pivot top of center section into backpan and align with upper pivot bushing. (**FIGURE F**)

8. Use hand to insert and fully tighten pivot pin into upper bushing, and then back out one turn. Repeat for lower bushing with second pivot pin. (**FIGURE E**)

9. Re-install the security clips to prevent unintentional pivot pin removal. (**FIGURE D**)

NOTE: Side view shown.

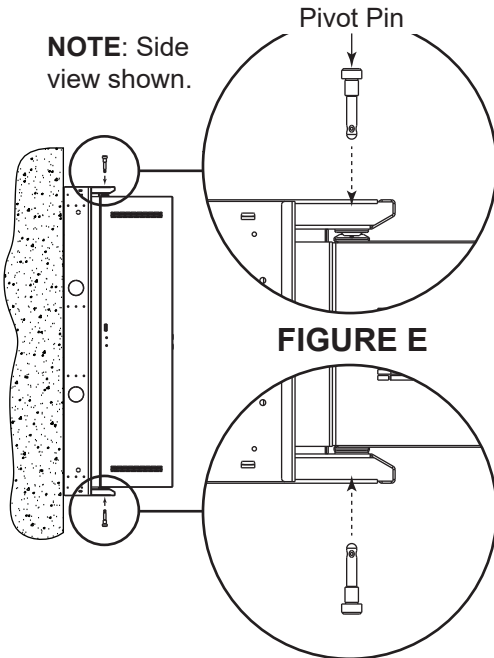

NOTE: When installing front door, the factory rackrail setback will be 1½" (38 mm) to the inside of the door. The lock and handle located at the center of the door has an additional setback of ½" (13 mm).

Please adjust your rackrail accordingly before installing equipment.

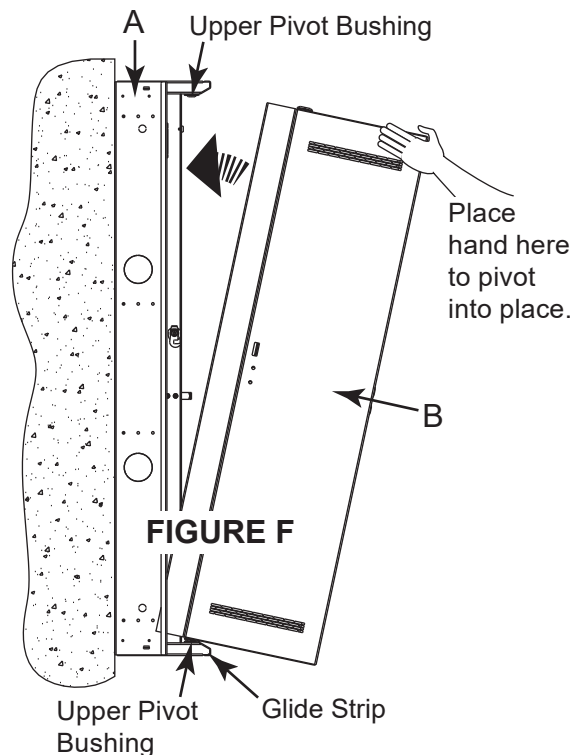

10. Use electric drill, 5/16" socket, and the screws pre-installed on the back of the center section (B) to install trim (C) on the pivot side of the center section as shown. (**FIGURE G**)

NOTE:

- If using electric drill, verify the torque is on the lightest setting and only increase as necessary.
- Thread cutting screws are provided on both sides of the center section for convenience. Leave unused thread cutting screws in place on opposite side.

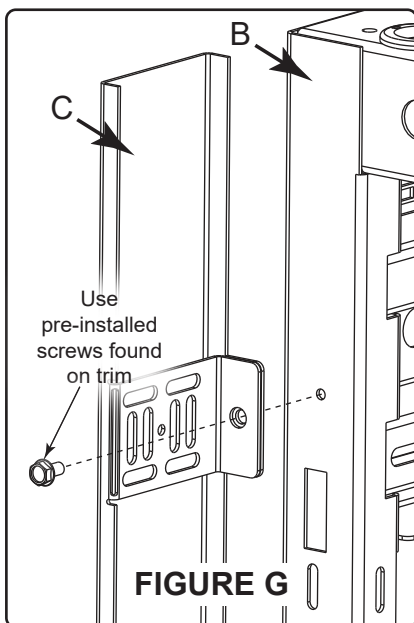

GROUNDING AND BONDING

Protective Earth Terminals (PET) are located in backpan of the wall rack. These terminals are marked with the symbol . Wall rack parts, center section and door, contain or are provided with bonding points for connection to the backpan / PET. Protective earth and bonding connections shall be in accordance with Article 250 of the National Electric Code.

PROTECTIVE EARTH TERMINAL KIT (MODEL NO. PET-K-D/EWR, OPTIONAL)



12 Gauge Backpan Bonding Wire
14" (356 mm) Length
(#10 to 1/4" ring terminals)



1/4-20
Flange
Nut



10-32
Locking
Nut

PROTECTIVE EARTH TERMINAL KIT (MODEL NO. PET-K-D/EWRD, OPTIONAL)

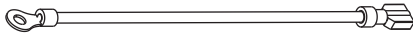

12 Gauge Door Bonding Wire
6" (152 mm) Length
(#10 ring terminal to male disconnect)

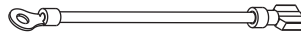

12 Gauge Door Bonding Wire
4" (102 mm) Length
(#10 ring terminal to female disconnect)



M4 x 0.7
Thread Forming
Screw



10-32
Locking
Nut

1. Use 7/16" wrench and 1/4"-20 flange nut to attach the larger ring terminal on the backpan bonding wire to the protective earth terminal (PET) in your backpan (A). (**FIGURE H**)
 2. Use 3/8" wrench and 10-32 nut to attach the other end of the backpan bonding wire to the nearest 10-32 center section (B) bonding stud.
- NOTE:**
- The main protective earth ground needs to be the first terminal placed on the PET and this terminal needs to be secured on its own with a nut. The bonding wire for the center section can be added to the PET after securing the nut for the main ground.
 - Use the remaining steps to attach the optional door, if applicable.
3. Use #2 Phillips screwdriver and the M4 x 0.7 thread forming screw to attach the ring terminal end of a door bonding wire to one of the door bonding point holes. (**FIGURE H**)
 4. Use 3/8" wrench and 10-32 nut to attach the ring terminal end of the other door bonding wire to one of the center section bonding studs.
 5. Attach the disconnect ends of your door bonding wires together.

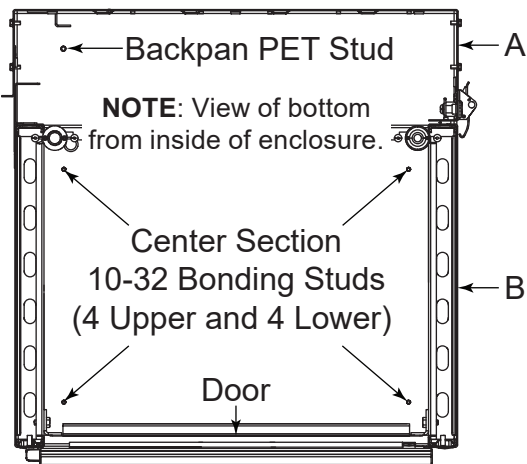
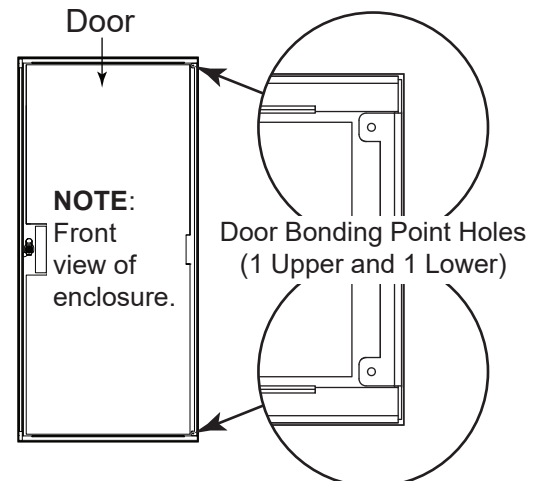
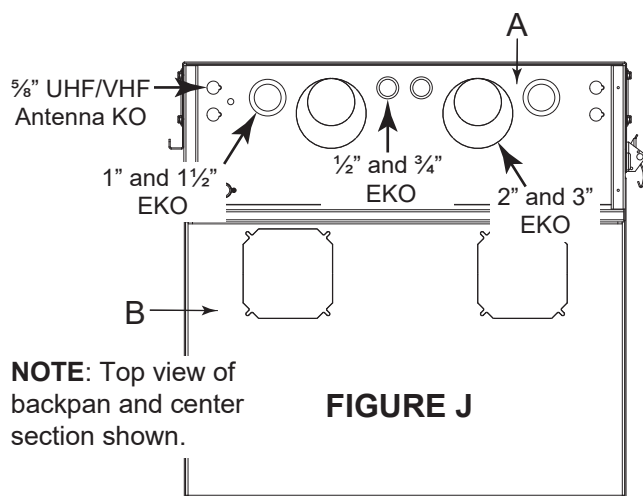

FIGURE H



CABLE MANAGEMENT

- Use hook and loop slots and/or cable ties provided on top, bottom, and sides of center section (B) for cable management. **(FIGURE I)**
- Use hook and loop slots and/or cable ties in Z-bracket for cable management.
- Use hook and loop slots and/or cable ties in bridge lances on backpan (A) for cable management.



NOTE: Top view of backpan and center section shown.

FIGURE J

NOTE: Top view of backpan (A) and center section (B) shown.

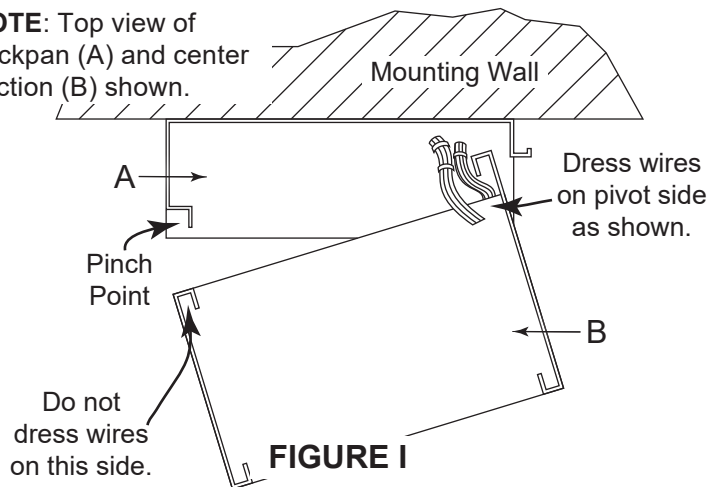

- Laser knockouts are located in the center of the backpan for large electrical boxes. **(FIGURE J)**
- Knockouts provided in top/bottom of backpan for electrical fittings, UHF/VHF antenna, and cable entry.

NOTE: Use a hammer to carefully clear any knockouts you wish to use.

NOTE:

- Optional grommets (Model No. GR-30) are available to protect wiring when using knockouts.
- The side of your backpan also includes knockouts for a variety of uses as shown. **(FIGURE K)**
- Use a hammer to carefully clear any knockouts you wish to use.

Middle Atlantic User Control Panel (UCP) Modules

UCP knockouts accommodate Middle Atlantic Products UCP modules, which provide interfaces for most input and output control panel connections.

Some of our UCP modules (Model Number: UNIV4 and XLR) provide the following control panel connections:

- UNIV4 fits Neutrik FP, MP, MDL and other connectors.
- XLR fits Neutrik MPL, LNEMP and other connectors.

For more information about UCP modules, refer to www.legrandav.com or contact support at 1-800-266-7225.

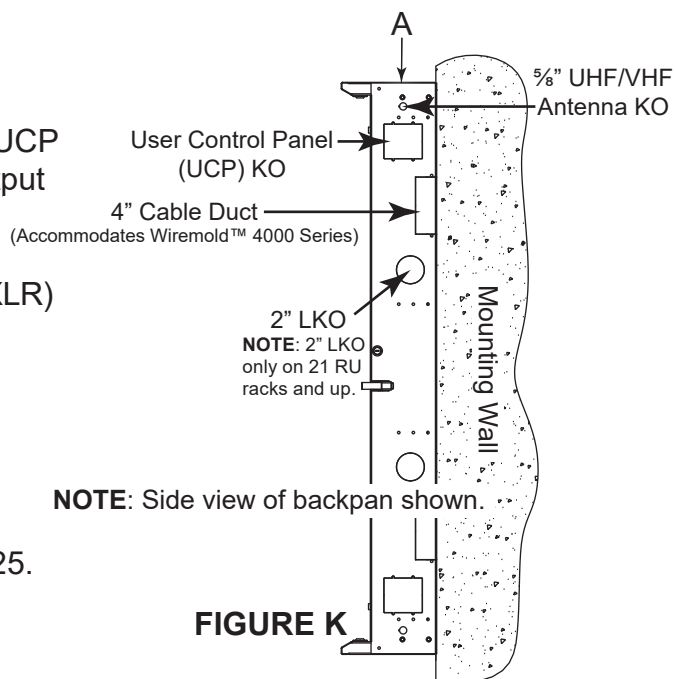

NOTE: Side view of backpan shown.

FIGURE K

INSTALLING POWER STRIPS

Compatible Middle Atlantic power strip options can be mounted inside the trim (C) with the included hardware. This simplifies cable management by requiring no additional accessories.

NOTE: Reference which power strip models are compatible with your specific size enclosure at www.legrandav.com.

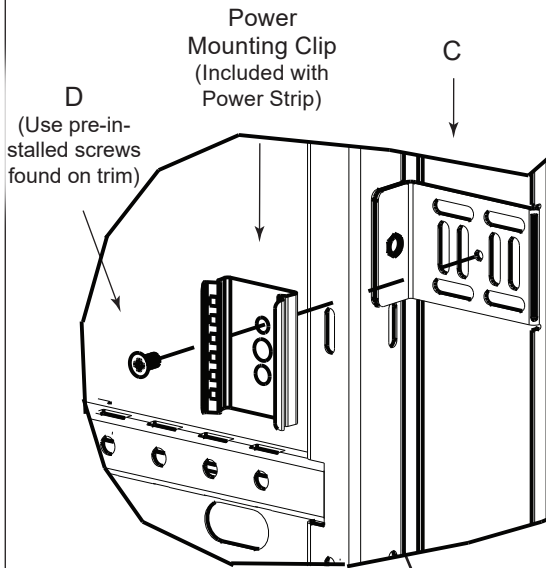
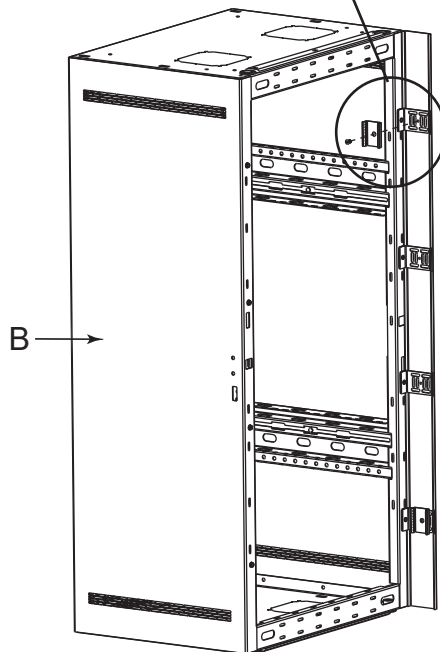

FIGURE L



1. Use electric drill and #2 Phillips bit to remove pre-installed flat head screw. (**FIGURE L**)
2. Use drill, Phillips bit and the flat head screw to secure each power mounting clip to the trim.

NOTE:

- Power strip sold separately. Power mounting clip(s) provided with strip.
- Reference the compatible power strip models for your specific size enclosure at www.legrandav.com to determine whether yours requires the use of 1 or 2 power mounting clips.
- Verify your electric drill torque is on the lightest setting and only increase as necessary.

2. Use a rubber mallet and gently tap your power strip into the power mounting clip(s), if needed.

TIP: To remove your power strip from the mounting clip(s), carefully wedge a #2 flat head screwdriver between the side of your power strip and mounting clip, and gently pry the strip from the clip(s) as shown. (**FIGURE M**)

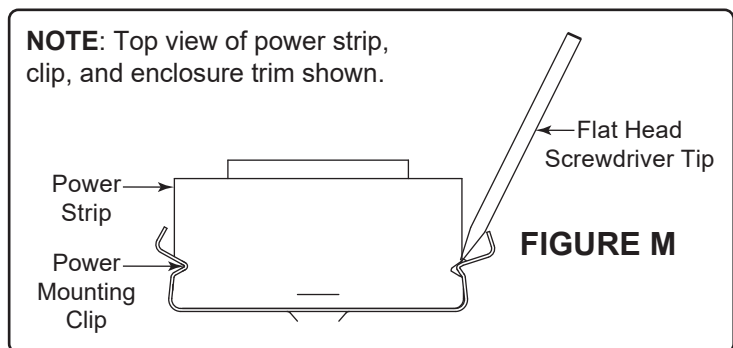

THERMAL KNOCKOUTS BASED ON ENCLOSURE DEPTHS

Thermal knockout sizes vary based on the following enclosure depths:

- Enclosures 17" (432 mm) and 22" (559 mm) deep accept (2x) 4" fans. (**FIGURE L**)
- Enclosures 26" (660 mm) and 32" (813 mm) deep accept (2x) 6" fans. (**FIGURE M**)

NOTE: Use a hammer to carefully clear any knockouts you wish to use.

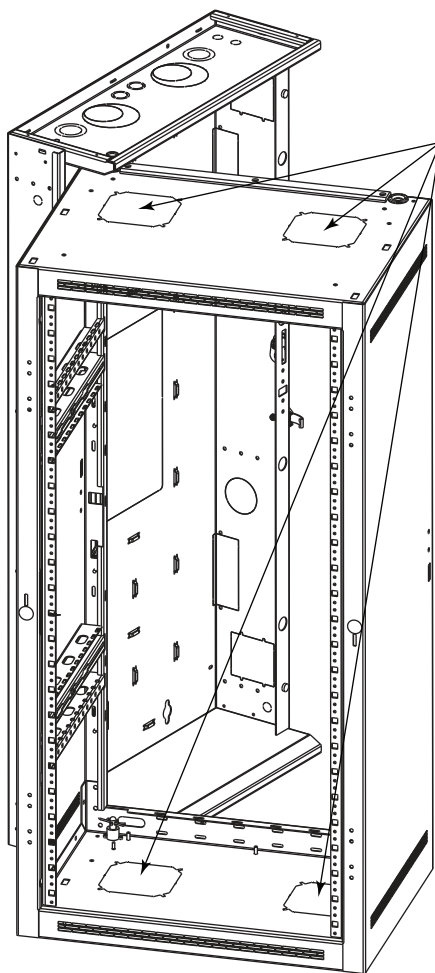

Knockouts
For 4" Fans

FIGURE L

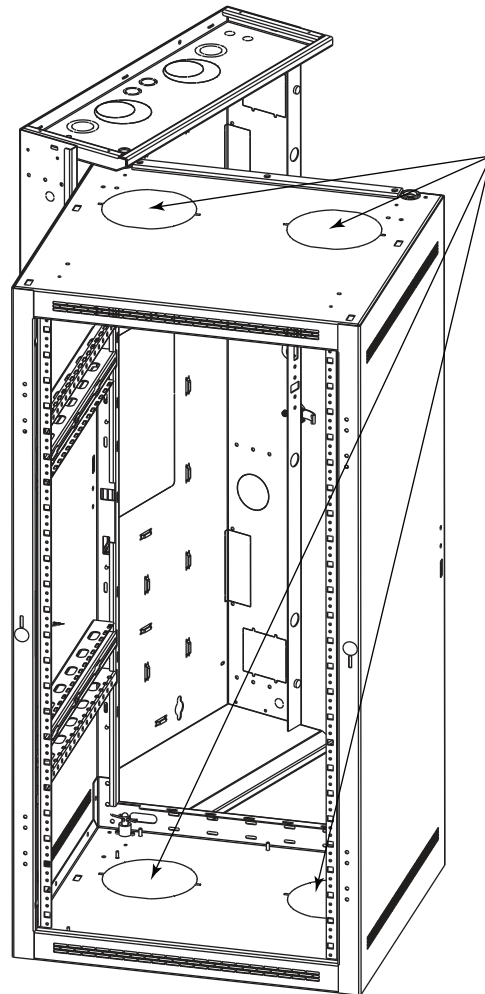

Knockouts
For 6" Fans

FIGURE M

WARRANTY

For warranty information, refer to www.legrandav.com/policies/warranty_information.

Contacting Corporate Headquarters

P: (866) 977-3901 | F: (877) 894-6918 | www.legrandav.com | av.support@legrand.com

Contacting Middle Atlantic Canada

P: (888) 766-9770 | F: (888) 599-5009 | www.legrand.ca/middle-atlantic-products | av.canada.customerservice@legrand.com

Contacting Middle Atlantic Europe, Middle East, and Africa (EMEA) Technical Support

P: +31 495-726-003 | av.emea.middleatlantic.support@legrand.com

United States (US)

Legrand | AV Headquarters
10900 Red Circle Drive
Minnetonka, MN, 55343, USA

European Union (EU)

Legrand AV Netherlands
B.V. Franklinstraat 14 6003
DK, Weert, Netherlands

United Kingdom (UK)

Starline Holding Technology Ltd.
(Authorized Representative)
Unit C, Island Rd.
Reading RG2, 0RP- UK

At Legrand AV Inc we are always listening. Your comments are welcome.

Legrand AV is an ISO 9001 and ISO 14001 Registered Company.

MIDDLE ATLANTIC®

A brand of  legrand®