



B-TECH AV MOUNTS™

B-TECH AV MOUNTS

IDEAL FOR
 PROJECTION
 MAPPING

BT898

ENHANCED PITCH STACKABLE HEAVY DUTY PROJECTOR FLOOR MOUNT WITH PULL-OUT SERVICE TRAY



Designed to floor mount projectors up to 75kg, this heavy duty mount can be stacked to create a column of XL projectors. Similar to the BT897 projector mount, the BT898 features enhanced pitch of 30° for a greater angle of adjustment (accommodated by a taller cage to protect the projector at the enhanced angle). The projector fixes to a slide out tray which allows for quick and easy servicing without needing to disassemble any part of the installation. Pitch, yaw and roll micro-adjustment allows easy alignment of projected images. Cable management is included for a neat and tidy installation. This projector can be used independently or in conjunction with the BT897 heavy duty stackable projector mount.

SPECIFICATION

Max Load	75kg per unit
Max Projector Size	up to W: 800 x D: 1000 x H: 350mm
Tilt (Pitch)	+30° (+4.5° with micro-adjustment)
Yaw	2.5° (with micro-adjustment)
Roll	+4.5° (with micro-adjustment)

Projector mount must be bolted to the floor

FEATURES

- Ideal for projection mapping
- Modular design allows mounts to be stacked (to a max height of 2.6m)
- Projector tray slides out to allow access to the projector for servicing & adjustment*
- Projector can be quickly connected or disconnected for off-site servicing if required
- Tool-less micro adjustment
- Tilt, pitch and yaw positions are maintained while projector is disconnected, eliminating the need to re-calibrate micro-adjustments after servicing
- Quick and easy assembly
- Integrated cable management
- Open design gives suitable ventilation for projectors
- Designed for indoor or outdoor use when protected in a sheltered environment

**Only one projector can be in the service position at one time*



Slide out tray allows quick and easy servicing without any disassembly

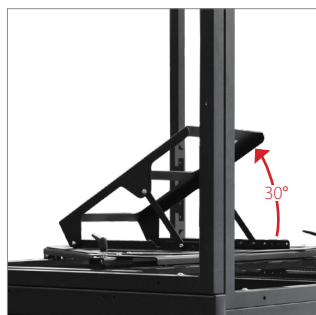

Features enhanced pitch of 30° in 5° increments



Micro-adjustment for perfectly framed projection



Can be used in conjunction with the BT897 Stackable Projector Mount (middle/ bottom tiers)



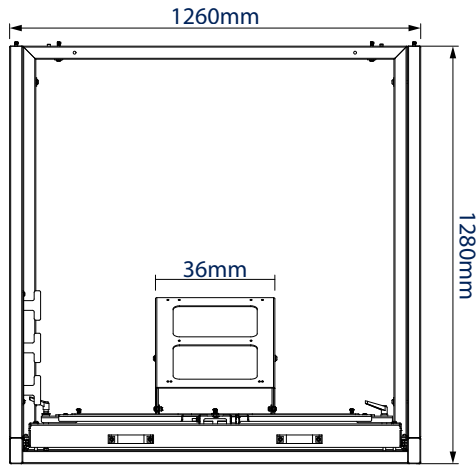

FRONT VIEW

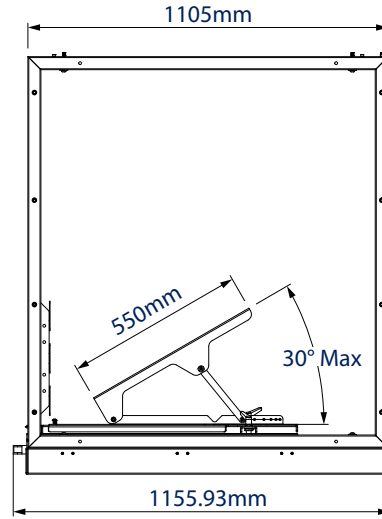

SIDE VIEW

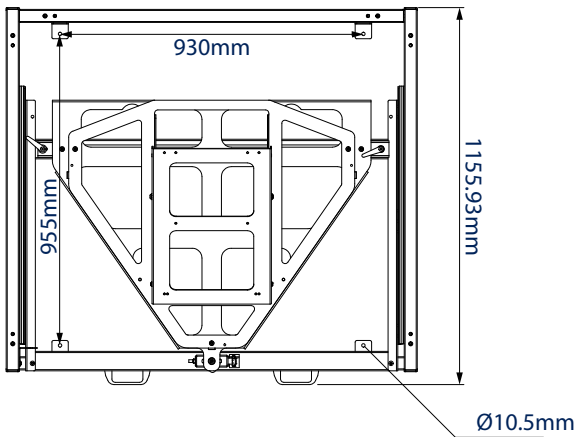

TOP VIEW

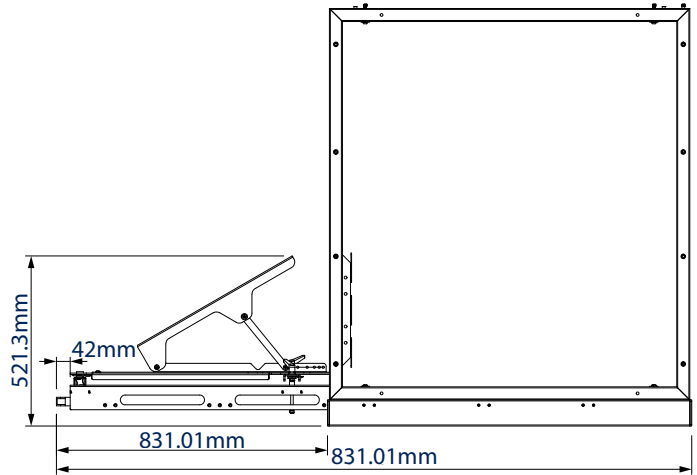

SIDE VIEW TRAY EXTENDED

PACKING INFORMATION

COLOUR:	ORDER REF:	EAN CODE:	MASTER CARTON QTY:	INNER CARTON QTY:	MASTER CARTON WEIGHT:	MASTER CARTON CUBE:
Black	BT898/B	5019318081200	N/A	N/A	N/A	N/A

ORIGINAL DESIGNS BY B-TECH AV MOUNTS - REGISTERED DESIGNS & PATENTS APPLY

ACCESSORIES AND RELATED PRODUCTS

<p>BT897</p> <p>Stackable Heavy Duty Projector Mount designed for projectors up to 75kg</p>	<p>BT893</p> <p>Heavy Duty Projector Ceiling Mount for projectors up to 70kg</p>	<p>BT893-AD</p> <p>Adjustable Drop Heavy Duty projector Ceiling Mount for projectors up to 70kg</p>	<p>BT893-FD</p> <p>Fixed Drop Heavy Duty projector Ceiling mount for projectors up to 70kg</p>
---	--	---	--

© 2018 B-Tech Av Mounts. All rights reserved.
 The information in this document is subject to change without notice. B-Tech Av Mounts and B-Tech logo are registered trademarks of B-Tech International Design & Manufacturing Ltd.
 B-Tech Av Mounts is not liable for loss or damage caused by improper or negligent installation, use, or modification of any part of this product.
 B-Tech Av Mounts is not responsible for any loss or damage caused by improper or negligent installation, use, or modification of any part of this product.
 SS-BT898-V1-070318