

Easy UPS 3M

60-200 kVA

Operation

09/2019

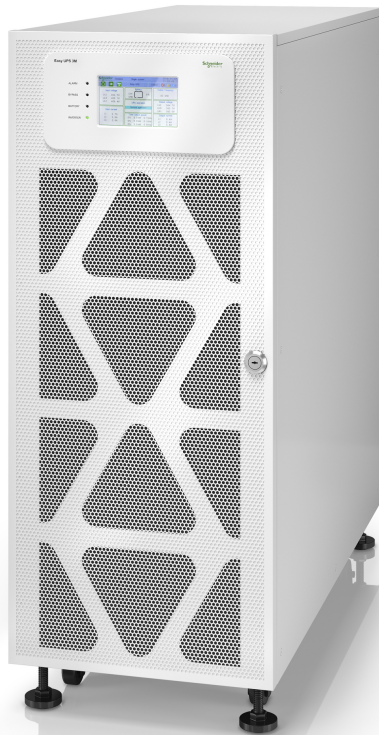

Legal Information

The Schneider Electric brand and any trademarks of Schneider Electric SE and its subsidiaries referred to in this guide are the property of Schneider Electric SE or its subsidiaries. All other brands may be trademarks of their respective owners.

This guide and its content are protected under applicable copyright laws and furnished for informational use only. No part of this guide may be reproduced or transmitted in any form or by any means (electronic, mechanical, photocopying, recording, or otherwise), for any purpose, without the prior written permission of Schneider Electric.

Schneider Electric does not grant any right or license for commercial use of the guide or its content, except for a non-exclusive and personal license to consult it on an "as is" basis. Schneider Electric products and equipment should be installed, operated, serviced, and maintained only by qualified personnel.

As standards, specifications, and designs change from time to time, information contained in this guide may be subject to change without notice.

To the extent permitted by applicable law, no responsibility or liability is assumed by Schneider Electric and its subsidiaries for any errors or omissions in the informational content of this material or consequences arising out of or resulting from the use of the information contained herein.



Go to <http://www.productinfo.schneider-electric.com/portals/ui/easyups3m/> for translations.

Rendez-vous sur <http://www.productinfo.schneider-electric.com/portals/ui/easyups3m/> pour accéder aux traductions.

Vaya a <http://www.productinfo.schneider-electric.com/portals/ui/easyups3m/> para obtener las traducciones.

Gehe zu <http://www.productinfo.schneider-electric.com/portals/ui/easyups3m/> für Übersetzungen.

Vai a <http://www.productinfo.schneider-electric.com/portals/ui/easyups3m/> per le traduzioni.

Vá para <http://www.productinfo.schneider-electric.com/portals/ui/easyups3m/> para obter as traduções.

Перейдите по ссылке <http://www.productinfo.schneider-electric.com/portals/ui/easyups3m/> для просмотра переводов.

前往 <http://www.productinfo.schneider-electric.com/portals/ui/easyups3m/> 查看译文。

前往 <http://www.productinfo.schneider-electric.com/portals/ui/easyups3m/> 查看譯文。

Table of Contents

Important Safety Instructions — SAVE THESE	
INSTRUCTIONS	5
Electromagnetic Compatibility	6
Safety Precautions	6
Overview	7
User Interface	7
Status LEDs	7
EPO	7
Display Menu Tree.....	8
Location of Breakers	9
Overview of Single UPS	10
Overview of 1+1 Redundant Parallel System with Common Battery	
Bank.....	11
Overview of Parallel System	11
Operation Modes	14
Operation Procedures	18
View System Status Information	18
Start Up a Single UPS in Normal Mode	18
Transfer a Single UPS from Normal Mode to Static Bypass Mode.....	19
Transfer a Single UPS from Static Bypass Mode to Normal Mode.....	19
Transfer a Single UPS from Normal Mode to Maintenance Bypass	
Mode	20
Transfer a Single UPS from Maintenance Bypass Mode to Normal	
Mode	20
Transfer a Parallel System from Normal Mode to Maintenance Bypass	
Mode	21
Transfer a Parallel System from Maintenance Bypass Mode to Normal	
Mode	22
Isolate a Single UPS from the Parallel System	22
Start Up and Add a UPS to a Running Parallel System	23
Configuration	25
Default Settings	25
Set the Display Language	26
Configure the Display Settings	27
Configure the Network Settings	27
Change the Display Password	28
Set the Date and Time	28
Configure the UPS Settings	29
Configure the Output Settings.....	29
Configure the Battery Settings	30
Configure the Input Contacts and Output Relays.....	31
Configure Life Cycle Monitoring	33
Enable/Disable Buzzer.....	34
Maintenance	35
Parts Replacement	35
Determine if you need a Replacement Part	35
Replace the Air Filter	35

Replace a Battery String	36
Troubleshooting	39
View the Active Alarms.....	39
Clear Alarm.....	39
View the Log	39
Calibrate the Display.....	40

Important Safety Instructions — SAVE THESE INSTRUCTIONS

Read these instructions carefully and look at the equipment to become familiar with it before trying to install, operate, service or maintain it. The following safety messages may appear throughout this manual or on the equipment to warn of potential hazards or to call attention to information that clarifies or simplifies a procedure.



The addition of this symbol to a “Danger” or “Warning” safety message indicates that an electrical hazard exists which will result in personal injury if the instructions are not followed.



This is the safety alert symbol. It is used to alert you to potential personal injury hazards. Obey all safety messages with this symbol to avoid possible injury or death.

DANGER

DANGER indicates a hazardous situation which, if not avoided, **will result in death or serious injury.**

Failure to follow these instructions will result in death or serious injury.

WARNING

WARNING indicates a hazardous situation which, if not avoided, **could result in death or serious injury.**

Failure to follow these instructions can result in death, serious injury, or equipment damage.

CAUTION

CAUTION indicates a hazardous situation which, if not avoided, **could result in minor or moderate injury.**

Failure to follow these instructions can result in injury or equipment damage.

NOTICE

NOTICE is used to address practices not related to physical injury. The safety alert symbol shall not be used with this type of safety message.

Failure to follow these instructions can result in equipment damage.

Please Note

Electrical equipment should only be installed, operated, serviced, and maintained by qualified personnel. No responsibility is assumed by Schneider Electric for any consequences arising out of the use of this material.

A qualified person is one who has skills and knowledge related to the construction, installation, and operation of electrical equipment and has received safety training to recognize and avoid the hazards involved.

Electromagnetic Compatibility

NOTICE

RISK OF ELECTROMAGNETIC DISTURBANCE

This is a product Category C3 according to IEC 62040-2. This is a product for commercial and industrial applications in the second environment - installation restrictions or additional measures may be needed to prevent disturbances. The second environment includes all commercial, light industry, and industrial locations other than residential, commercial, and light industrial premises directly connected without intermediate transformer to a public low-voltage mains supply. The installation and cabling must follow the electromagnetic compatibility rules, e.g.:

- the segregation of cables,
- the use of shielded or special cables when relevant,
- the use of grounded metallic cable tray and supports.

Failure to follow these instructions can result in equipment damage.

Safety Precautions

DANGER

HAZARD OF ELECTRICAL SHOCK, EXPLOSION OR ARC FLASH

All safety instructions in this document must be read, understood and followed.

Failure to follow these instructions will result in death or serious injury.

DANGER

HAZARD OF ELECTRICAL SHOCK, EXPLOSION OR ARC FLASH

After the UPS system has been electrically wired, do not start up the system. Start-up must only be performed by Schneider Electric.

Failure to follow these instructions will result in death or serious injury.

Overview

User Interface

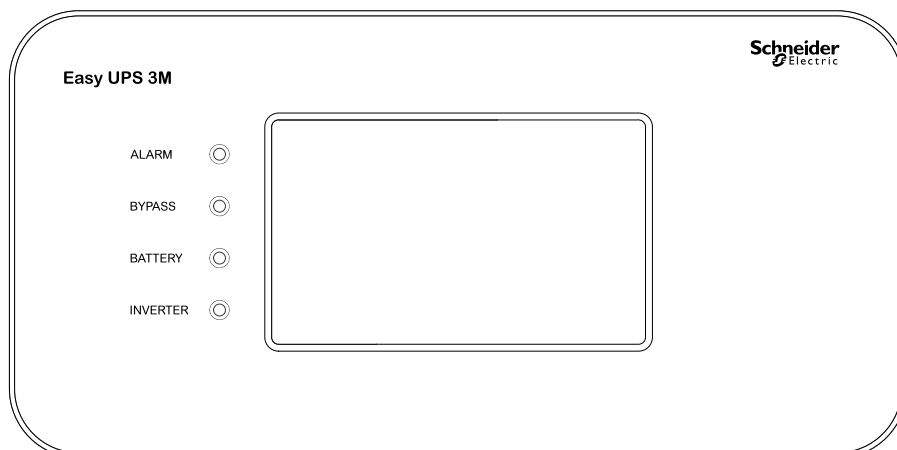

Status LEDs

LED	State	Description
ALARM	Steady red	Critical alarm
	Flashing red	Warning alarm
	Off	No alarm condition
BYPASS	Steady yellow	The load is supplied by the bypass source
	Flashing yellow	There is an alarm condition on the bypass source
	Off	The load is not supplied by the bypass source
BATTERY	Steady yellow	The load is supplied by the battery source
	Flashing yellow	The battery source is unavailable
	Off	The load is not supplied by the battery source
INVERTER	Steady green	Inverter on
	Off	Inverter off

EPO

Only use the EPO button in case of emergency.

It can be configured whether, when the EPO button is pressed, the UPS should:

- turn off the rectifier, inverter, charger, and static bypass and stop supplying the load immediately, or
- transfer to static bypass mode and keep supplying the load.

⚠ DANGER

HAZARD OF ELECTRIC SHOCK, EXPLOSION, OR ARC FLASH

The UPS control circuit will remain active after the EPO has been pushed if mains is available.

Failure to follow these instructions will result in death or serious injury.

Display Menu Tree

- **Status**
 - Input
 - Output
 - Battery
 - Bypass
 - Status information
- **Alarms**
 - Active alarms
 - Enable buzzer/Disable buzzer
 - Log
- **Settings**
 - **General settings**
 - Language settings
 - Display settings
 - Network
 - Password settings
 - Date and time
 - UPS information
 - **Advanced settings**
 - System settings
 - Output settings
 - Bypass settings
 - Parallel settings
 - Battery settings
 - Contacts and relays
- **Service**
 - Battery self-test
 - Export data to USB
 - Display calibration
 - LCM settings
- **Control**
 - Inverter ON/OFF
 - Clear alarm(s)
 - Self-test
- **About**

Location of Breakers

60-100 kVA UPS for External Batteries

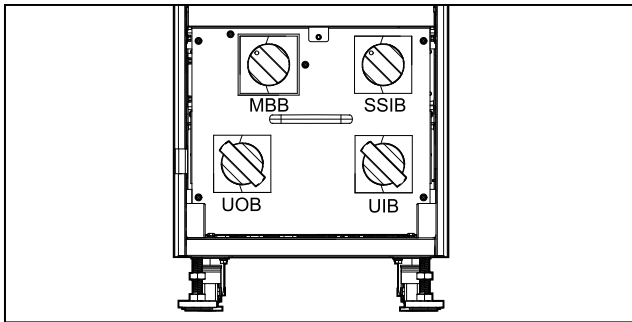

120-160 kVA UPS for External Batteries

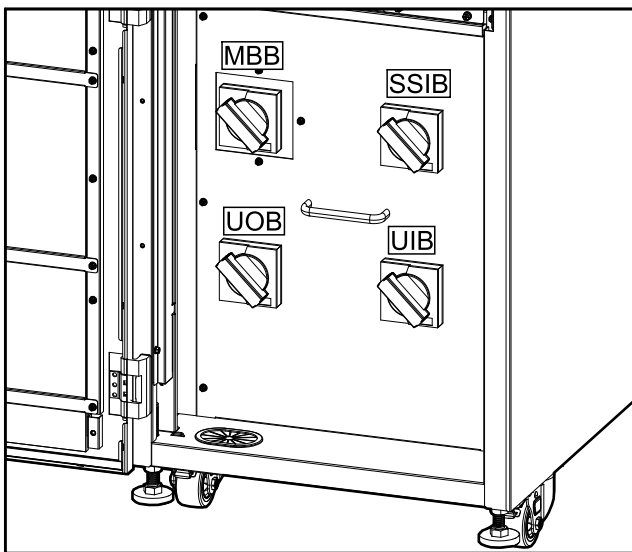

200 kVA UPS for External Batteries

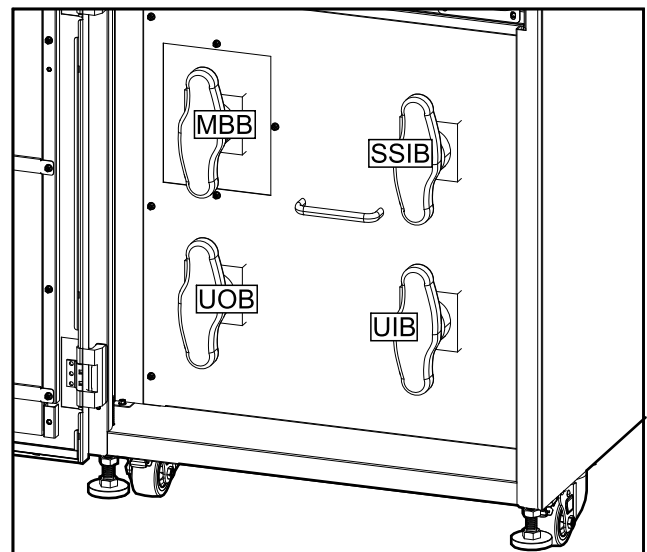

Front View of the 60 kVA UPS for Internal Batteries

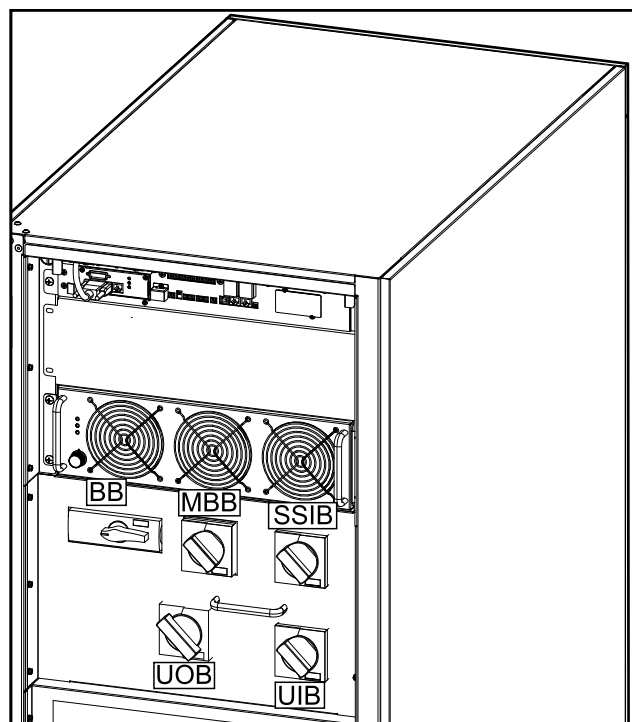

Front View of the 80 kVA UPS for Internal Batteries

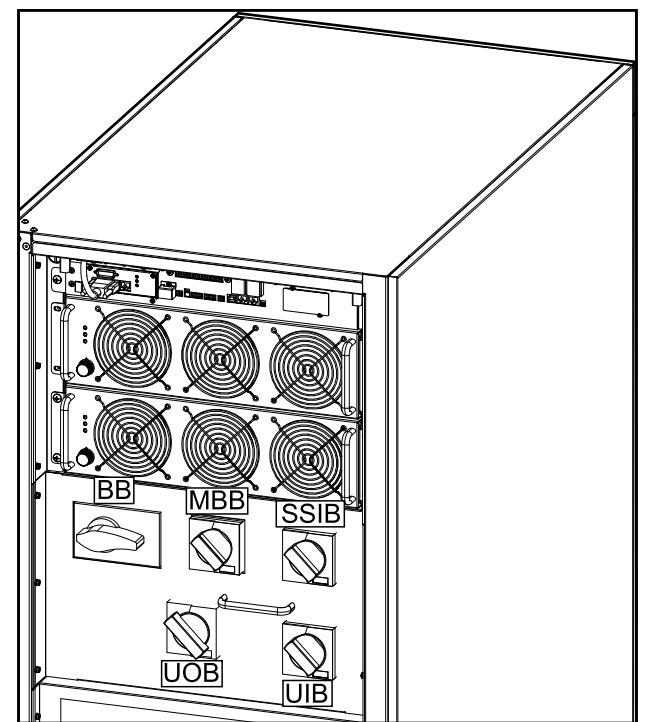

Overview of Single UPS

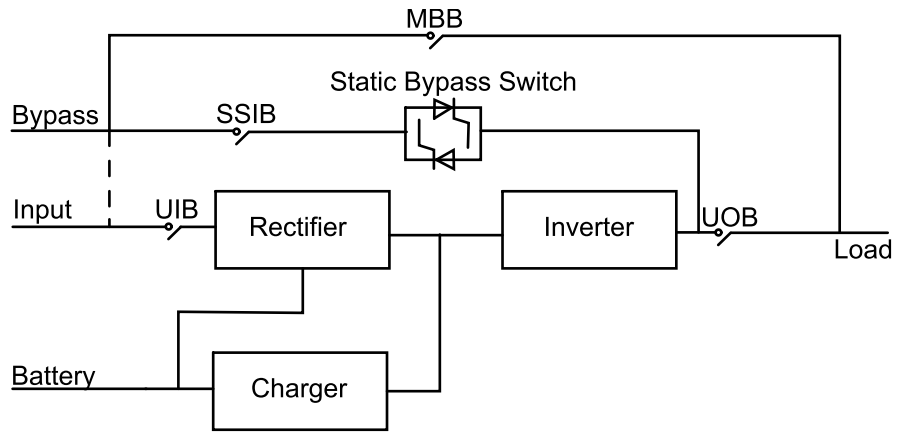

UIB	Unit input breaker
SSIB	Static switch input breaker
UOB	Unit output breaker
MBB	Maintenance bypass breaker

Overview of 1+1 Redundant Parallel System with Common Battery Bank

NOTE: Common battery banks are not supported in systems with internal batteries.

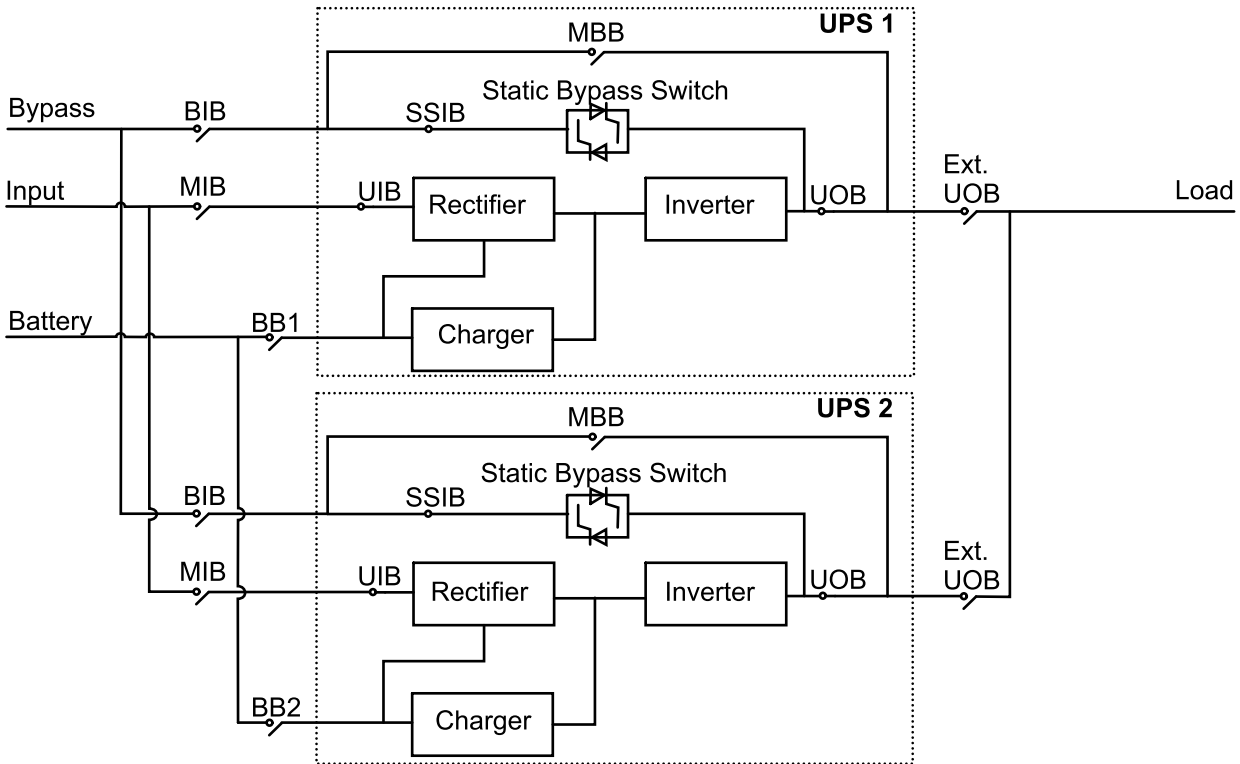

MIB	Mains input breaker
BIB	Bypass input breaker
UIB	Unit input breaker
SSIB	Static switch input breaker
UOB	Unit output breaker
Ext. UOB	External unit output breaker
MBB	Maintenance bypass breaker
Ext. MBB	External maintenance bypass breaker
BB1	Battery breaker 1
BB2	Battery breaker 2

Overview of Parallel System

NOTE: In parallel systems with an external maintenance bypass breaker Ext. MBB, the maintenance bypass breakers MBB must be padlocked in the open position.

UPSs for External Batteries

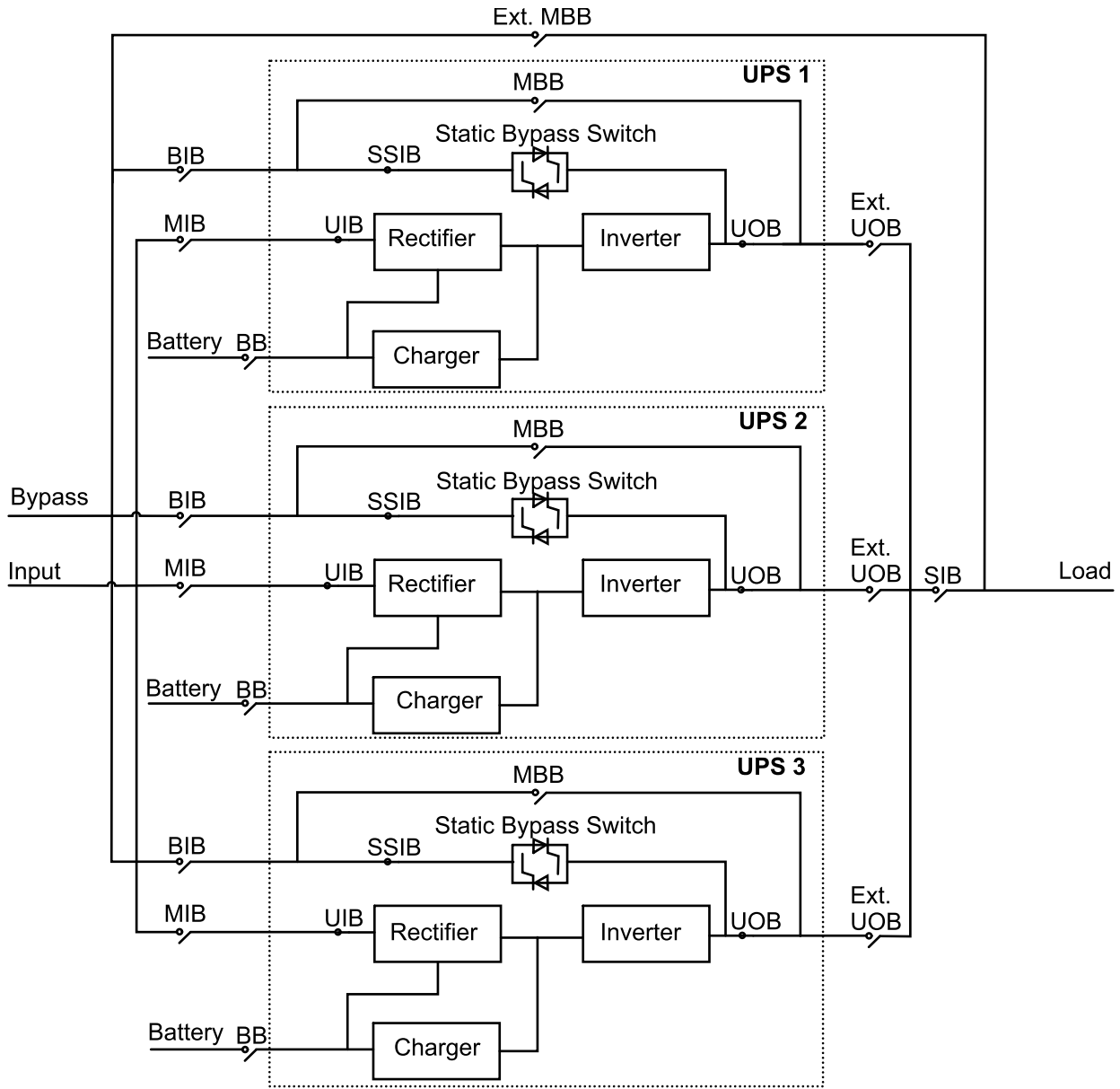

UPSs for Internal Batteries

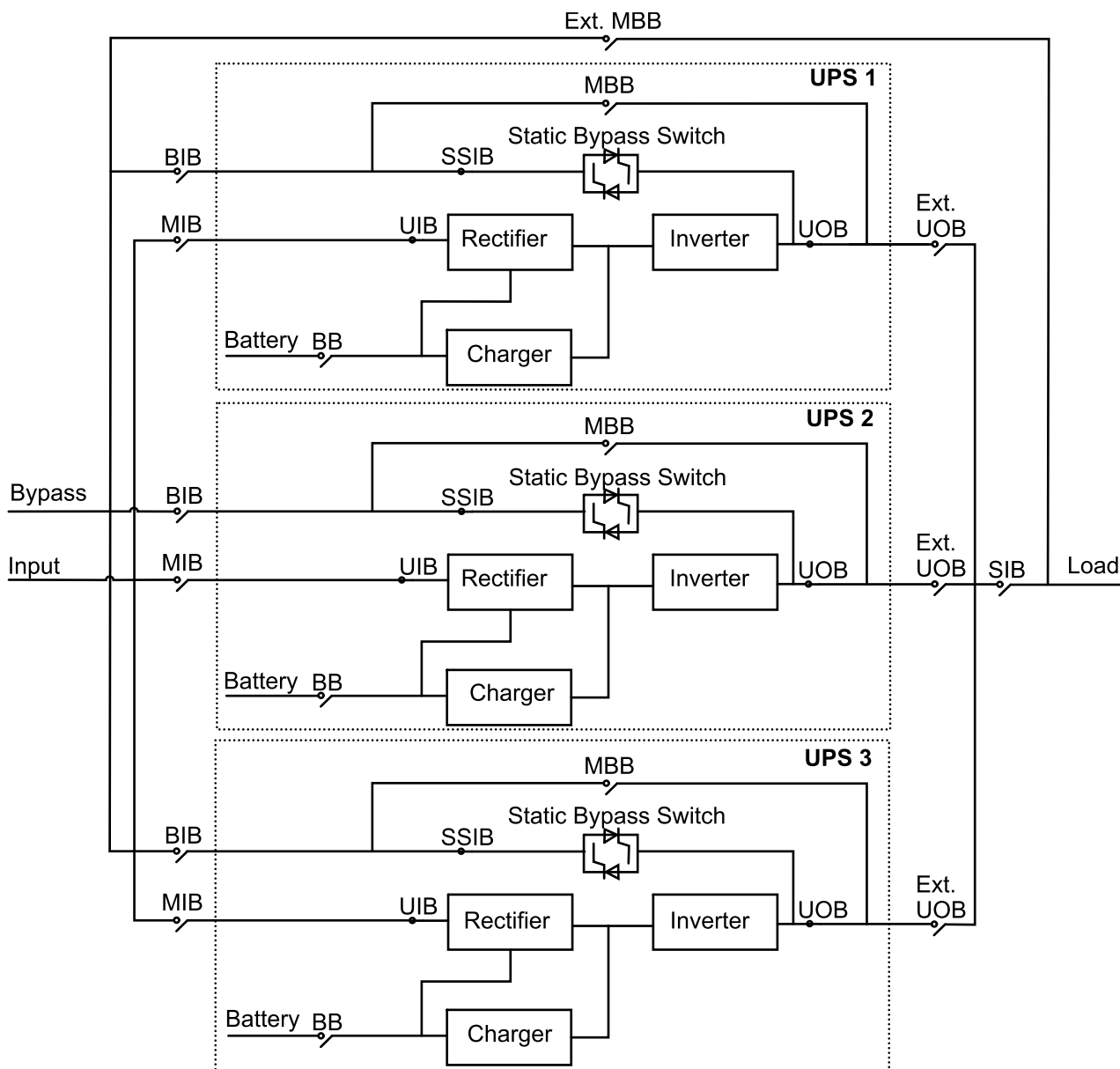

MIB	Mains input breaker
BIB	Bypass input breaker
UIB	Unit input breaker
SSIB	Static switch input breaker
UOB	Unit output breaker
Ext. UOB	External unit output breaker
MBB	Maintenance bypass breaker
Ext. MBB	External maintenance bypass breaker
SIB	System isolation breaker
BB	Battery breaker

Operation Modes

Normal Mode

The UPS provides power to the connected load from mains. The UPS converts mains to conditioned power for the connected load while recharging the batteries (float or boost charge).

LED Status

- ALARM
- BYPASS
- BATTERY
- INVERTER

Power Flow

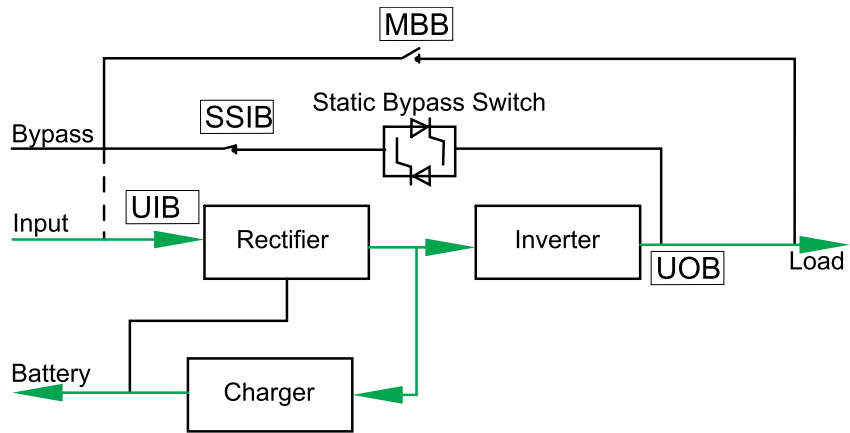

Battery Mode

The UPS transfers to battery mode if the mains supply fails. The UPS provides power to the connected load from the connected batteries for a finite period. When the mains supply returns, the UPS transfers back to normal mode.

LED Status

- ALARM
- BYPASS
- BATTERY
- INVERTER

Power Flow

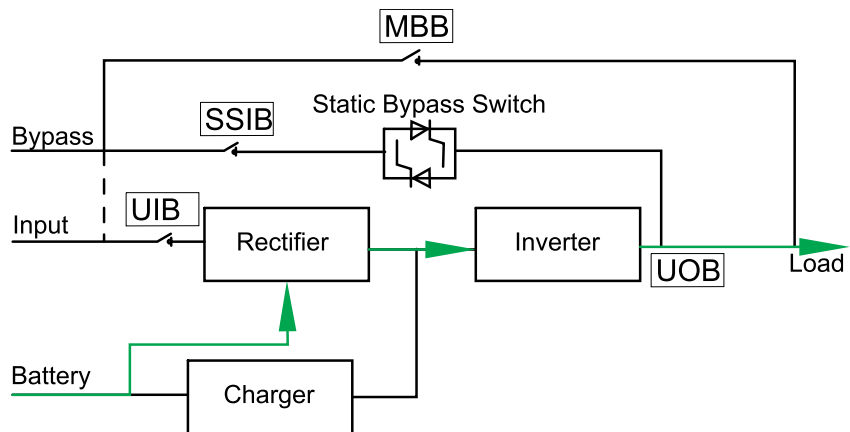

Static Bypass Mode

The UPS supplies the load with power from the bypass source. If the conditions for normal or battery mode are not met, the load will be transferred from the inverter to the bypass source with no interruption in power to the load.

LED Status

- ALARM
- BYPASS
- BATTERY
- INVERTER

Power Flow

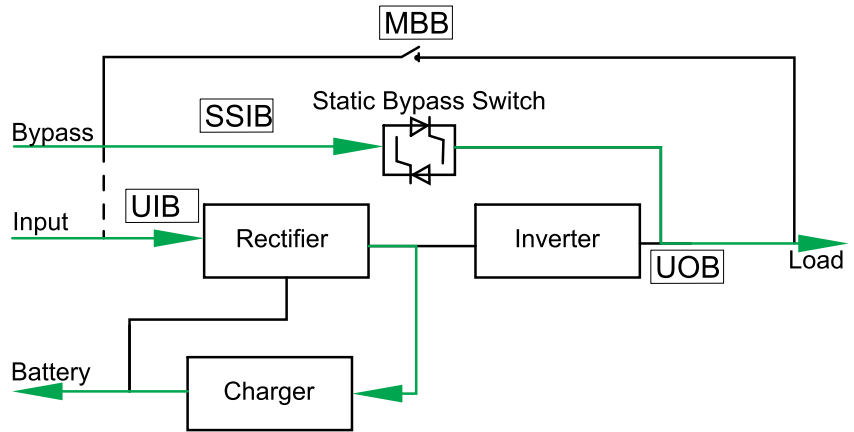

Maintenance Bypass Mode

In maintenance bypass mode, the mains is sent via the (external) maintenance bypass breaker (MBB) to the load. Battery backup is not available in maintenance bypass mode.

LED Status

- ALARM
- BYPASS
- BATTERY
- INVERTER

Power Flow

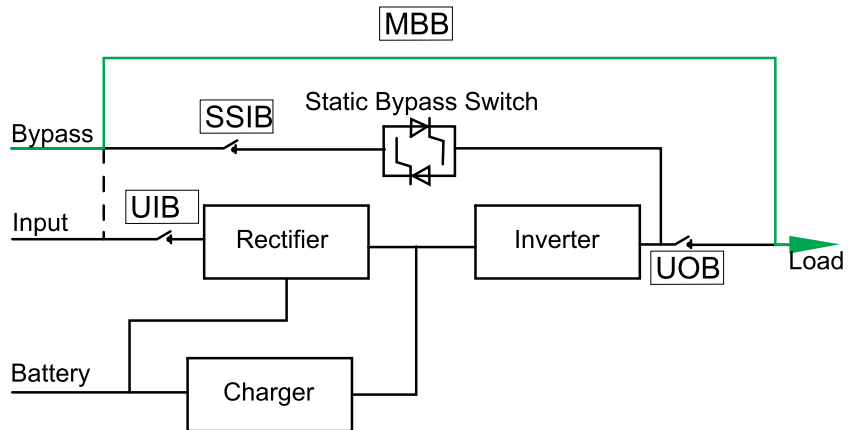

ECO Mode

In ECO mode the UPS is configured to use static bypass mode as the preferred operation mode under predefined circumstances. The inverter is in standby in ECO mode and in case of interruption to the mains, the UPS transfers to battery mode and the load is supplied from the inverter.

LED Status

- ALARM
- BYPASS
- BATTERY
- INVERTER

Power Flow

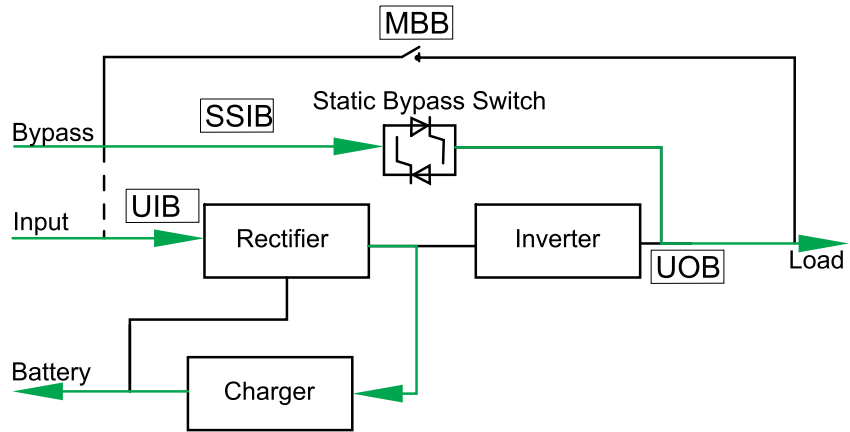

Autostart Mode

When autostart is enabled, the UPS automatically restarts the inverter and bypass when the mains returns. By default autostart is enabled.

NOTE: If autostart is disabled, the inverter and bypass will not restart automatically when the mains return.

Frequency Converter Mode

In frequency converter mode, the UPS presents a stable output frequency (at 50 or 60 Hz) and the static bypass switch is not available.

NOTICE

RISK OF EQUIPMENT DAMAGE OR LOAD DROP

In frequency converter mode the UPS cannot run in static bypass or maintenance bypass mode. Before turning the UPS into frequency converter mode, you must contact a Schneider Electric-certified partner to make sure

- the static switch input breaker SSIB and the maintenance bypass breaker MBB are in the OFF (opened) position (Schneider Electric strongly recommends to lock these with a padlock available from Schneider Electric)
- no cables are connected to the bypass terminals

Failure to follow these instructions can result in equipment damage.

NOTICE

RISK OF LOAD DROP

When the unit output breaker UOB is opened while the UPS is in frequency converter mode, the load will not be transferred, but will be dropped.

Failure to follow these instructions can result in equipment damage.

LED Status

ALARM

BYPASS

BATTERY

INVERTER

Power Flow

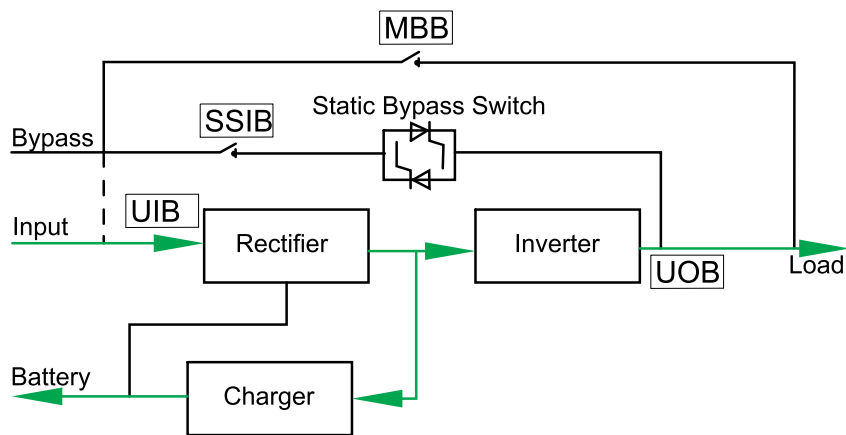

Operation Procedures

View System Status Information

1. From the home screen of the display select **Status**.
2. You can now select to view status information for:
 - **Input**
 - **Output**
 - **Battery**
 - **Bypass**
 - **Status information**

Start Up a Single UPS in Normal Mode

NOTE: When the UPS starts up, any stored settings will be used.

1. Check that all breakers are in the OFF (open) position.
2. Turn the static switch input breaker SSIB to the ON (closed) position.
The display turns on and the Home screen is shown.
3. Turn the unit output breaker UOB to the ON (closed) position.
Wait approximately 30 seconds until the bypass LED turns steady yellow. The UPS starts up in static bypass mode.
4. Turn the unit input breaker UIB to the ON (closed) position.
The rectifier ramps up. When the rectifier is ready, the inverter starts up and synchronizes with bypass.

The LEDs on the user interface show as follows:

ALARM 

BYPASS 

BATTERY 

INVERTER 

5. Wait approximately 20 seconds until inverter LED turns steady green, the UPS transfers automatically from static bypass mode to normal mode.

The LEDs on the user interface show as follows:

ALARM 

BYPASS 

BATTERY 

INVERTER 

Transfer a Single UPS from Normal Mode to Static Bypass Mode

1. From the home screen on the display select **Control > Inverter OFF**.

The UPS transfers from normal to static bypass mode without an interruption to the load.

The LEDs on the user interface show as follows:

ALARM 

BYPASS 

BATTERY 

INVERTER 

Transfer a Single UPS from Static Bypass Mode to Normal Mode

NOTE: The UPS will normally transfer automatically from static bypass to normal mode. This procedure can be used to manually transfer to normal mode if the bypass frequency or voltage is above the specified limits.

1. From the home screen of the display select **Control > Inverter ON**.

The LEDs on the user interface show as follows:

ALARM 

BYPASS 

BATTERY 

INVERTER 

Transfer a Single UPS from Normal Mode to Maintenance Bypass Mode

1. From the home screen on the display select **Control > Inverter OFF**.
2. Turn the maintenance bypass breaker MBB to the ON (closed) position.
The load is now supplied via the maintenance bypass breaker.
3. Turn the battery breaker(s) BB to the OFF (open) position.
4. Turn the unit input breaker UIB to the OFF (open) position.
5. Turn the static switch input breaker SSIB to the OFF (open) position.
6. Turn the unit output breaker UOB to the OFF (open) position.

DANGER

HAZARD OF ELECTRIC SHOCK, EXPLOSION, OR ARC FLASH

- Wait at least 5 minutes before removing the cover of the UPS after the display has turned off to allow for the capacitors to fully discharge.
- Always measure for hazardous voltages on all terminals before working on the UPS.

Failure to follow these instructions will result in death or serious injury.

Transfer a Single UPS from Maintenance Bypass Mode to Normal Mode

1. Check that all breakers except maintenance bypass breaker MBB are in the OFF (open) position.
2. Turn the static switch input breaker SSIB to the ON (closed) position.
The display turns on and the Home screen is shown.
3. Turn the unit output breaker UOB to the ON (closed) position.
The UPS starts up in static bypass mode.
4. Turn the unit input breaker UIB to the ON (closed) position.
The rectifier ramps up.
5. Turn the battery breaker(s) BB to the ON (closed) position.

- Turn the maintenance bypass breaker MBB to the OFF (open) position.
The UPS automatically transfers to normal mode.

ALARM

BYPASS

BATTERY

INVERTER

Transfer a Parallel System from Normal Mode to Maintenance Bypass Mode

⚠️⚠️ DANGER

HAZARD OF ELECTRIC SHOCK, EXPLOSION, OR ARC FLASH

To completely isolate the UPSs, all upstream breakers (mains input breakers MIB, bypass input breakers BIB, and system isolation breaker SIB) must be in the OFF (open) position.

Failure to follow these instructions will result in death or serious injury.

- From the home screen on the display select **Control > Inverter OFF > Parallel OFF**.
All UPSs will turn to static bypass mode.
- Turn the external maintenance bypass breaker Ext. MBB to the ON (closed) position.
The load is now supplied via the external maintenance bypass breaker.
- Turn the battery breakers BB of all UPSs to the OFF (open) position.
- Turn the mains input breakers MIB and the bypass input breakers BIB of all UPSs to the OFF (open) position if available.
- Turn the unit input breakers UIB and the static switch input breakers SSIB of all UPSs to the OFF (open) position.
- Turn the unit output breakers UOB of all UPSs and the system isolation breaker SIB to OFF (open) position.

⚠️⚠️ DANGER

HAZARD OF ELECTRIC SHOCK, EXPLOSION, OR ARC FLASH

- Wait at least 5 minutes before removing the cover of the UPS after the display has turned off to allow for the capacitors to fully discharge.
- Always measure for hazardous voltages on all terminals before working on the UPS.

Failure to follow these instructions will result in death or serious injury.

Transfer a Parallel System from Maintenance Bypass Mode to Normal Mode

1. Check that:
 - a. All upstream breakers (mains input breakers MIB, bypass input breakers BIB, and system isolation breaker SIB) are in the OFF (open) position.
 - b. All UPS breakers (unit input breakers UIB, static switch input breakers SSIB, and unit output breakers UOB) and the external unit output breakers Ext. UOB are in the ON (closed) position.
 - c. The battery breakers BB are in the OFF (open) position.
2. Turn the system isolation breaker SIB and the unit output breakers UOB of all UPSs to ON (closed) position.
3. Turn the bypass input breakers BIB and the static switch input breakers of all UPSs to the ON (closed) position.
Wait approximately 20 seconds until the bypass LEDs turn yellow.
4. Turn the external maintenance bypass breaker Ext. MBB to the OFF (open) position.
5. Turn the mains input breakers MIB and the unit input breakers UIB of all UPSs to the ON (closed) position.
When the inverter LED turns steady green, the parallel system automatically transfers from static bypass to normal mode.
6. Turn the battery breakers of all UPSs to the ON (closed) position.
The LEDs on the user interfaces show as follows:

ALARM 

BYPASS 

BATTERY 

INVERTER 

The parallel system is now in normal mode.

Isolate a Single UPS from the Parallel System

Use this procedure to shut down one UPS in a running parallel system.

NOTE: Before initiating this procedure, ensure that the remaining UPS units can supply the load.

1. Turn the static switch input breaker SSIB of the UPS to the OFF (open) position.
2. From the home screen on the display select **Control > Inverter OFF > Single OFF**.
3. Turn the battery breaker(s) BB of the UPS to the OFF (open) position.
4. Turn the mains input breaker MIB of the UPS to the OFF (open) position.
5. Turn the bypass input breaker BIB of the UPS to the OFF (open) position.

6. Turn the external unit output breaker Ext. UOB of the UPS to the OFF (open) position.

⚠️⚠️ DANGER

HAZARD OF ELECTRIC SHOCK, EXPLOSION, OR ARC FLASH

- Wait at least 5 minutes before removing the cover of the UPS after the display has turned off to allow for the capacitors to fully discharge.
- Always measure for hazardous voltages on all terminals before working on the UPS.

Failure to follow these instructions will result in death or serious injury.

Start Up and Add a UPS to a Running Parallel System

Use this procedure to start up a UPS and add it to a running parallel system.

IMPORTANT: Before a UPS can be added to a parallel system, the parallel system must be configured by Schneider Electric.

⚠️⚠️ DANGER

HAZARD OF ELECTRIC SHOCK, EXPLOSION, OR ARC FLASH

Ensure that the external unit output breaker Ext. UOB, the mains input breaker MIB, and the bypass input breaker BIB for the UPS are in the OFF (open) position before connecting power cables to the UPS.

Failure to follow these instructions will result in death or serious injury.

1. On the new UPS check that:
 - a. All UPS breakers (unit input breaker UIB, static switch input breaker SSIB, and unit output breaker UOB) and the external unit output breaker Ext. UOB are in the OFF (open) position.
 - b. The battery breaker(s) BB are in the OFF (open) position.
2. Turn the external unit output breaker Ext. UOB of the UPS to the ON (closed) position.
3. Turn the mains input breaker MIB and the bypass input breaker BIB of the UPS to the ON (closed) position.
4. Turn the unit input breaker UIB, the static switch input breaker SSIB, and the unit output breaker UOB of the UPS to the ON (closed) position.

When the inverter LED turns steady green, the UPS has joined the running parallel system.

The LEDs on the user interface show as follows:

ALARM 

BYPASS 

BATTERY 

INVERTER 

5. Turn the battery breaker(s) BB of the UPS to the ON (closed) position.
6. Verify correct load sharing between the parallel UPS units.

Configuration

Default Settings

Setting	Default Value		Available Settings
	UPS for External Batteries	UPSs for Internal Batteries	
Display brightness	63	63	1-63
Backlight timeout (sec)	60	60	10-255
Device ID	1	1	1-255
Baud rate	9600	9600	2400, 4800, 9600, 14400, 19200
Password timeout (minutes)	3	3	0-120
Date	2015-01-01	2015-01-01	
Time	00:00:00	00:00:00	
Operation mode	Single mode	Single mode	Single mode, ECO mode, Parallel mode, Parallel ECO mode
Autostart	Enable	Enable	Enable, Disable
Self-aging load rate (%)	60	60	18-100
Frequency converter mode	Disable	Disable	Disable, Enable
LBS operation	LBS disabled	LBS disabled	LBS disabled, LBS master, LBS slave
Transfer delay (sec)	1	1	0- 20
Par. transfer delay (sec)	10	10	0 -200
EPO transfers to bypass	Disable	Disable	Disable, Enable
Output frequency (Hz)	50	50	50, 60
Output voltage (V)	400	400	380, 400, 415
Output volt. compensation (%)	0.0	0.0	-5.0, -4.5, -4.0, -3.5, -3.0, -2.5, -2.0, -1.5, -1.0, -0.5, 0.0, 0.5, 1.0, 1.5, 2.0, 2.5, 3.0, 3.5, 4.0, 4.5, 5.0
Min. bypass RMS voltage (V)	-10	-10	-10, -15, -20, -30
Max. bypass RMS voltage (V)	10	10	10, 15, 20, 25
Bypass frequency range (%)	10	10	1, 2, 4, 5, 10
Output slew rate (Hz/sec)	0.5	0.5	0.5-2.0
Use bypass ON with overheated SCR	Disable	Disable	Disable, Enable
Allowed transfers to bypass	10	10	3-10
Parallel ID	1	1	1-6
Number of parallel UPSs	2	2	2-6
Number of par. redundant UPSs	0	0	0, 1, 2,3, 4, 5
Number of battery strings	1	3	1-8
Battery blocks per string	32	40	32, 34, 36, 38, 40, 42, 44, 46, 48, 50
Battery block capacity (Ah)	7	7	7-2000
Periodic boost charge (M)	0	0	0-24
Maximum charge current	0.1	0.1	0.05-0.15

Setting	Default Value		Available Settings
	UPS for External Batteries	UPSs for Internal Batteries	
Float voltage (V)	2.25	2.25	2.20-2.29
Boost voltage (V)	2.30	2.30	2.30-2.40
Boost charge duration (minutes)	240	240	0-999
Float temp. compensation	0.000	0.000	0.000-0.007
Boost charge	Disable	Disable	Enable, Disable
Alarm for no battery connected	Enable	Enable	Enable, Disable
Common battery bank	No	No	Yes, No
External batt. breaker status	Enable	Enable	Disable, Enable
Battery breaker trip	Enable	Enable	Disable, Enable
Backfeed on bypass	Enable	Enable	Disable, Enable
External MBB status	Disable	Disable	Disable, Enable
OUT 01	Disable	Disable	Disable, Common alarm, In normal operation, On battery, Static bypass, Maintenance bypass, Output overload, Fan inoperable, Battery inoperable, Battery disconnected, Battery voltage low, Input out of tol., Bypass out of tol., EPO active
OUT 02	Disable	Disable	
OUT 03	Disable	Disable	
OUT 04	Disable	Disable	
IN 01	Disable	Disable	Disable, INV ON, INV OFF, Battery inoperable, Genset on, Custom alarm 3, Custom alarm 4, Disable ECO, Force INV OFF
IN 02	Disable	Disable	
IN 03	Disable	Disable	
IN 04	Disable	Disable	
Self-test settings	Disable auto self-test	Disable auto self-test	Disable auto self-test, self-test every month, self-test every day
Self-test every	0 Day 0 hour 0 minute	0 Day 0 hour 0 minute	
Self-test type	Customize	Customize	10 seconds, 10 minutes, EOD, -10%, Customize
Air filter check (months)	3	3	0, 3, 4, 5, 12
Air filter counter (days)	0	0	

Set the Display Language

1. From the home screen of the display select **Settings > General settings > Language settings**.
2. Select your preferred language.
3. Tap **Save settings**.

Configure the Display Settings

1. From the home screen of the display select **Settings > General settings > Display settings**.

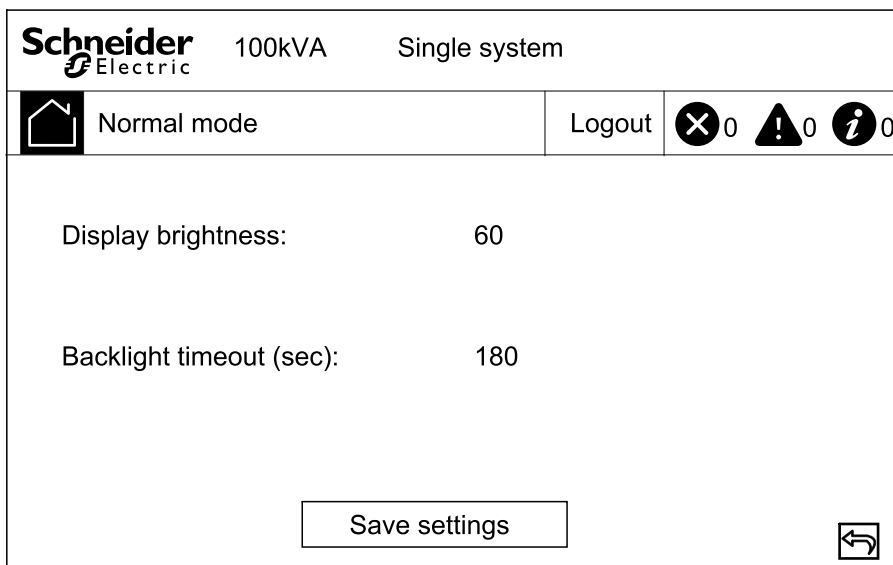

2. Set the **Display brightness** by choosing a value between 1 and 63.
3. Set the **Backlight timeout (sec)** by choosing a value between 10 and 255.
4. Tap **Save settings**.

Configure the Network Settings

1. From the home screen of the display select **Settings > General settings > Network**.

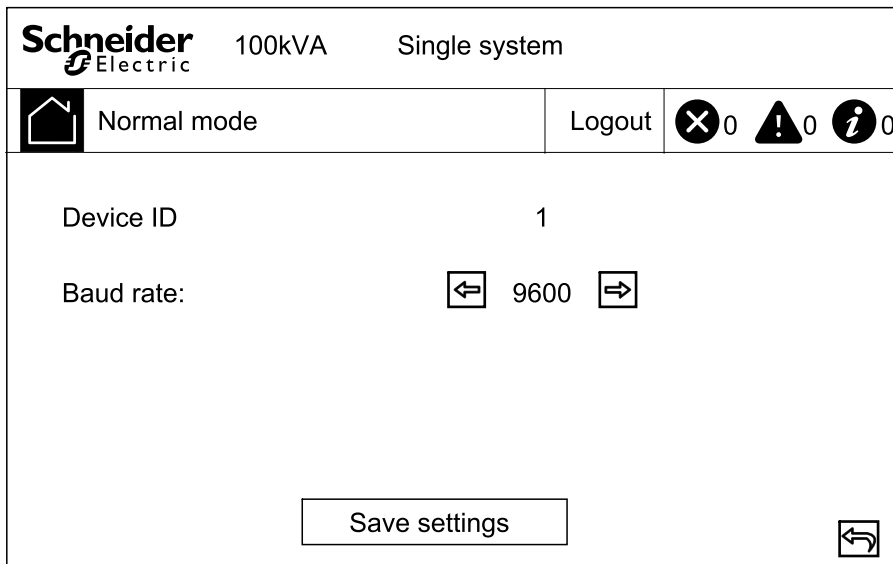

2. Set the **Baud rate** for communication using the left and right arrows. Choose between 2400, 4800, 9600, 14400, and 19200.
3. Tap **Save settings**.

Change the Display Password

1. From the home screen of the display select **Settings > General settings > Password settings**.

The screenshot shows the 'Password settings' screen. At the top, it displays the Schneider Electric logo, '100kVA', and 'Single system'. Below this is a navigation bar with a home icon, 'Normal mode', a 'Logout' button, and three status icons: a crossed-out circle with '0', a warning triangle with '0', and an information circle with '0'. The main area contains four input fields: 'Old password:', 'New password:', 'Repeat new password:', and 'Password timeout (minutes)' with the value '0'. A 'Save settings' button is located at the bottom center, and a back arrow icon is at the bottom right.

2. Type in **Old password**.
3. Type in **New password** and **Confirm new password**.
4. Set the time in minutes for automatic log out of the display after inactivity. Choose a value between 0 and 120.
5. Tap **Save settings**.

Set the Date and Time

1. From the home screen of the display select **Settings > General settings > Date and time**.

The screenshot shows the 'Date and time' settings screen. At the top, it displays the Schneider Electric logo, '100kVA', and 'Single system'. Below this is a navigation bar with a home icon, 'Normal mode', a 'Logout' button, and three status icons: a crossed-out circle with '0', a warning triangle with '0', and an information circle with '0'. The main area contains two input fields: 'Date:' with the placeholder 'XXXX-XX-XX' and 'Time:' with the placeholder 'XX:XX:XX'. A 'Save settings' button is located at the bottom center, and a back arrow icon is at the bottom right.

2. Set the **Date** using the keypad.
3. Set the **Time** using the keypad.
4. Tap **Save settings**.

Configure the UPS Settings

NOTICE
<p>RISK OF EQUIPMENT DAMAGE</p> <p>Only trained personnel following the required training must make modifications to the UPS system parameters.</p> <p>Failure to follow these instructions can result in equipment damage.</p>

- From the home screen of the display select **Settings > Advanced settings > System settings**.

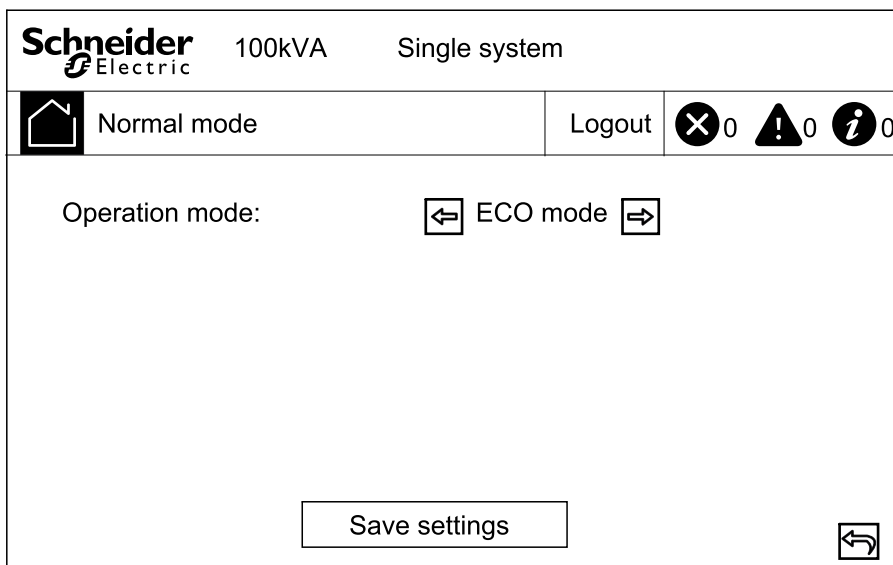











- Set the System mode. Choose between:
 - Choose **ECO mode** to use static bypass mode as the preferred operation mode.
 - Choose **Single mode** for a single UPS.
- Tap **Save settings**.

Configure the Output Settings

NOTICE
<p>RISK OF EQUIPMENT DAMAGE</p> <p>Only trained personnel following the required training must make modifications to the UPS system parameters.</p> <p>Failure to follow these instructions can result in equipment damage.</p>









- From the home screen of the display select **Settings > Advanced settings > Output settings**.

Schneider Electric		100kVA	Single system
 Normal mode	Logout	 0	 0
Output frequency (Hz):		50	
Output voltage (V):		400	
Output volt. compensation (%):		0.0	
<input type="button" value="Save settings"/>			

- Set the **Output frequency (Hz)**. Choose between 50 and 60 Hz.
- Set the **Output voltage (V)**. Choose between 380, 400, and 415 V.
- Set the output voltage compensation (%). Choose a value between –5 and 5.
- Tap **Save settings**.

Configure the Battery Settings

- From the home screen of the display select **Settings > Advanced settings > Battery settings** and configure the following settings.

Schneider Electric		100kVA	Single system
 Normal mode	Logout	 0	 0
Number of battery strings:		X	
Battery blocks per string:		XX	
Battery block capacity (Ah):		XX	
Periodic boost charge (M):		X	
<input type="button" value="Save settings"/>			

- Number of battery strings:** Set the number of battery strings in the battery solution.
- Battery blocks per string:** Set the number of battery blocks in one battery string.
- Battery block capacity (Ah):** Set the rated capacity of the battery block.
- Periodic boost charge (M):** Set the interval in months for changing from float charge to boost charge.

2. Tap arrow down and complete the following settings:

100kVA Single system	
Normal mode	Logout 0 0 0
Maximum charge current:	<input type="text" value="0.10"/> <input type="button" value="←"/> <input type="button" value="→"/> <input type="button" value="↑"/>
Float voltage (V):	<input type="text" value="2.25"/> <input type="button" value="←"/> <input type="button" value="→"/>
Boost voltage (V):	<input type="text" value="2.30"/> <input type="button" value="←"/> <input type="button" value="→"/> <input type="button" value="↓"/>
Boost charge duration (minutes):	<input type="text" value="240"/>
<input type="button" value="Save settings"/>	

- a. **Maximum charge current:** Choose a value between 0.05 and 0.15 C.
- b. **Float voltage (V):** Choose a value between 2.20 and 2.29
- c. **Boost voltage (V):** Set the upper limit for the boost charge voltage of a battery cell. Choose a value between 2.30 and 2.40.
- d. **Boost charge duration (minutes):** Set the duration of the boost charge. Choose a value between 0 and 999 minutes.

3. Tap arrow down and complete the following setting:

100kVA Single system	
Normal mode	Logout 0 0 0
Float temp. compensation:	<input type="text" value="0.003"/> <input type="button" value="←"/> <input type="button" value="→"/> <input type="button" value="↑"/>
<input type="button" value="Save settings"/>	

- a. **Float temp. compensation:** Choose a value between 0.000 and 0.007 V/°C per cell.

4. Tap **Save settings**.

Configure the Input Contacts and Output Relays

1. From the home screen of the display select **Settings > Advanced settings > Contacts and relays**.

2. Enable or Disable the following features:

- **External batt. breaker status**
- **Battery breaker trip**
- **Backfeed on bypass**
- **External MBB status**

100kVA
Single system

Normal mode

Logout
 0
 0
 0

External batt. breaker status:		Disable		
Battery breaker trip:		Disable		
Backfeed on bypass:		Disable		
External MBB status:		Disable		

Save settings

3. Tap arrow down and set the function for each of the configurable output relays. Choose between:

- | | |
|---|---|
| <ul style="list-style-type: none"> • Disable • Common alarm • In normal operation • On battery • Static bypass • Maintenance bypass • Output overload | <ul style="list-style-type: none"> • Fan inoperable • Battery inoperable • Battery disconnected • Battery voltage low • Input out of tol. • Bypass out of tol. • EPO active |
|---|---|

100kVA
Single system

Normal mode

Logout
 0
 0
 0

Out 01:		Disable		
Out 02:		Disable		
Out 03:		Disable		
Out 04:		Disable		

Save settings

4. Tap arrow down and set the function for each of the configurable input contacts. Choose between:

- **Disable**
- **INV ON**
- **INV OFF**
- **Battery inoperable**
- **Genset on**
- **Custom alarm 3**
- **Custom alarm 4**
- **Disable ECO**
- **Force INV OFF**

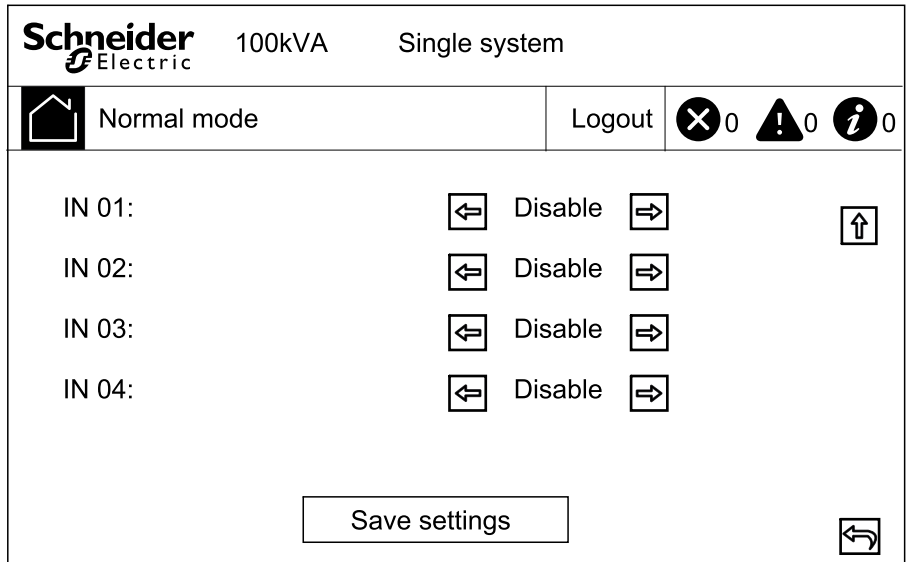

5. Tap **Save settings**.

Configure Life Cycle Monitoring

1. From the home screen of the display select **Service > LCM settings**.

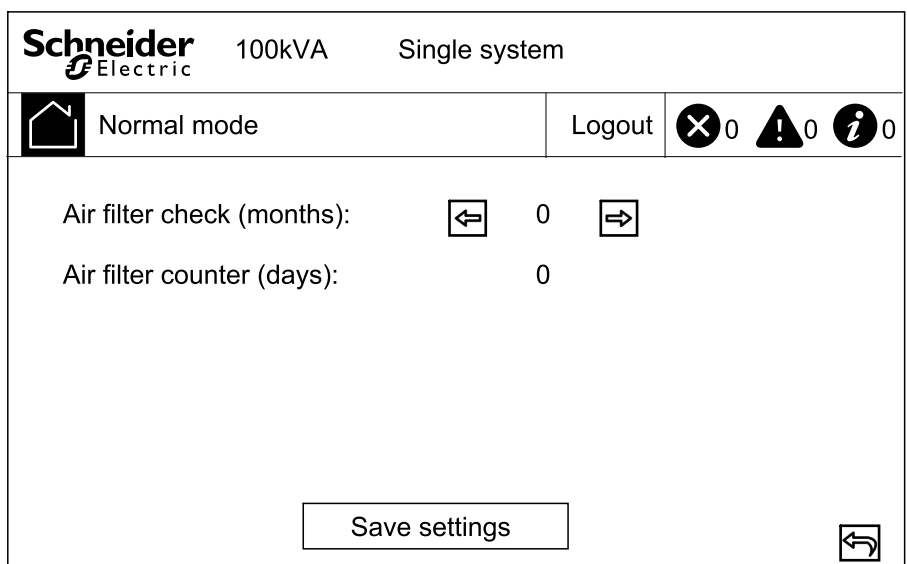

2. Set the time in months between air filter checks. The system will generate a **Check air filter** message when it is time to check the air filters.

3. Tap **Save settings**.

Enable/Disable Buzzer

1. From the home screen of the display select **Alarm(s)** and then select to either **Enable buzzer** or **Disable buzzer**.
2. Confirm your selection.

Maintenance

Parts Replacement

Determine if you need a Replacement Part

To determine if you need a replacement part, contact Schneider Electric and follow the procedure below so that the representative can assist you promptly:

1. In the event of an alarm condition, scroll through the alarm lists, record the information, and provide it to the representative.
2. Write down the serial number of the unit so that you will have it easily accessible when you contact Schneider Electric.
3. If possible, call Schneider Electric from a telephone that is within reach of the display so that you can gather and report additional information to the representative.
4. Be prepared to provide a detailed description of the problem. A representative will help you solve the problem over the telephone, if possible, or will assign a return material authorization (RMA) number to you. If a module is returned to Schneider Electric, this RMA number must be clearly printed on the outside of the package.
5. If the unit is within the warranty period and has been started up by Schneider Electric, repairs or replacements will be performed free of charge. If it is not within the warranty period, there will be a charge.
6. If the unit is covered by a Schneider Electric service contract, have the contract available to provide information to the representative.

Replace the Air Filter

1. Open the front door of the UPS.
2. Loosen the screws and remove the metal brackets.

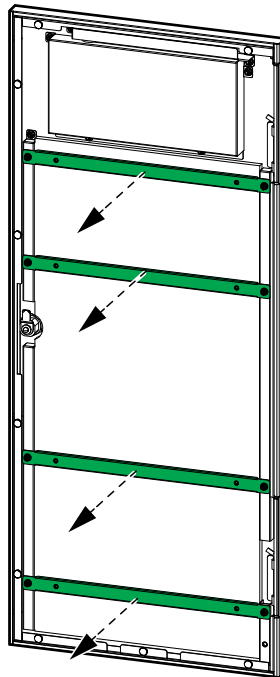

3. Replace the dust filter.

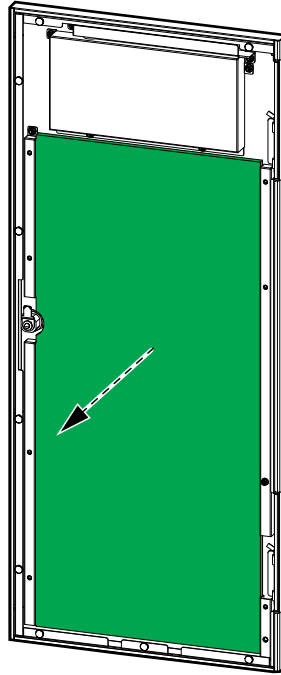

4. Reinstall the metal brackets and fasten with the screws.
5. Close the front door.
6. Reset the air filter counter in the display.

Replace a Battery String

⚡⚠ DANGER

HAZARD OF ELECTRIC SHOCK, EXPLOSION, OR ARC FLASH

Batteries can present a risk of electric shock and high short-circuit current. The following precautions must be observed when working on batteries

- Remove watches, rings, or other metal objects.
- Use tools with insulated handles.
- Wear protective glasses, gloves and boots.
- Do not lay tools or metal parts on top of batteries.
- Set the battery breaker BB to the open (OFF) position before starting this procedure.

Failure to follow these instructions will result in death or serious injury.

⚡⚠ DANGER

HAZARD OF ELECTRIC SHOCK, EXPLOSION, OR ARC FLASH

- Servicing of batteries must only be performed or supervised by qualified personnel knowledgeable of batteries and the required precautions. Keep unqualified personnel away from batteries.
- Do not dispose of batteries in a fire as they can explode.
- Do not open, alter, or mutilate batteries. Released electrolyte is harmful to the skin and eyes. It may be toxic.

Failure to follow these instructions will result in death or serious injury.

▲ WARNING**RISK OF EQUIPMENT DAMAGE**

- When replacing battery modules, always replace with the same battery module and always replace the entire battery string (four battery modules).
- Batteries must not be stored more than six months due to the requirement of recharging.

Failure to follow these instructions can result in death, serious injury, or equipment damage.

1. Set the battery breaker BB to the open (OFF) position.
2. Remove the plate in front of the battery modules.

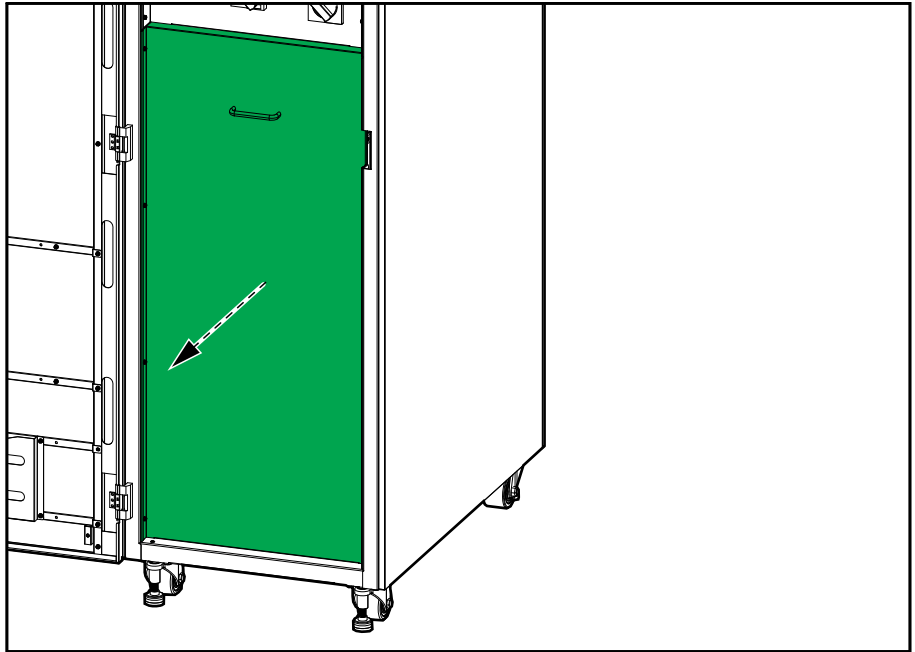

3. Disconnect the power terminal from the front of the battery module.

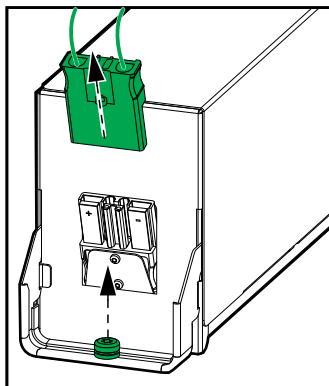

4. Remove the screw from the battery module handle and lift the handle upwards.

5. Pull the battery module carefully out of the slot.

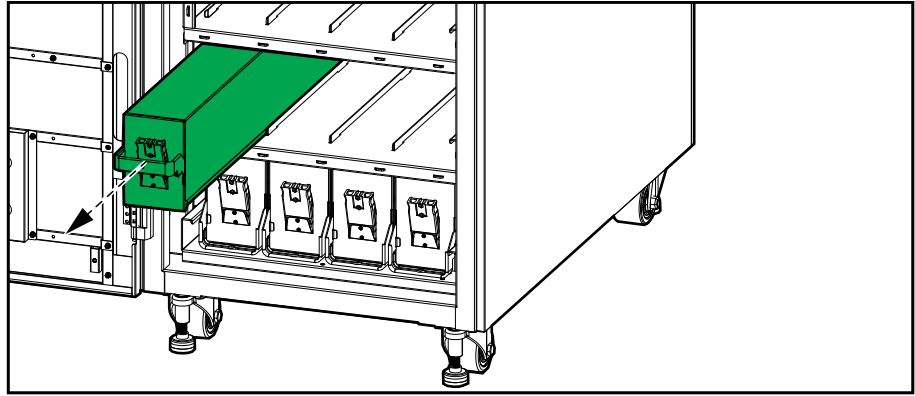

6. Repeat for all battery modules in the battery string. One row is one battery string.
7. Push the replacement battery modules into the UPS.
8. Lower the handles on the battery modules and fasten to the shelf with the screws.
9. Connect the power terminals to the front of the battery modules.
10. Reinstall the plate in front of the battery modules.
11. Set the battery breaker BB to the closed (ON) position.

Troubleshooting

View the Active Alarms

1. From the home screen of the display select **Alarm(s) > Active alarm(s)**.

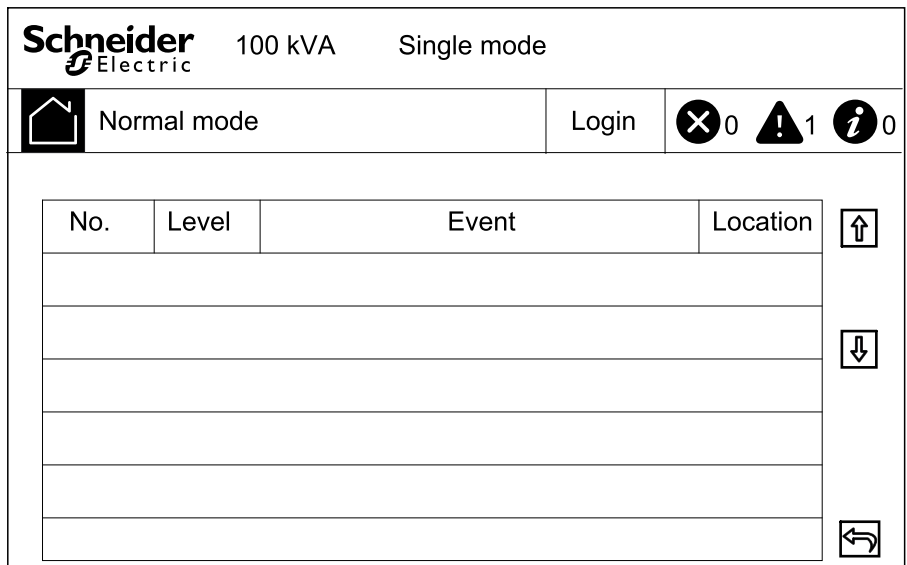

2. You can browse through the list of active alarms using the arrows.

Clear Alarm

1. Select **Control > Clear Alarm(s)** to clear the alarm list.

View the Log

1. From the home screen of the display select **Alarm(s) > Log**.

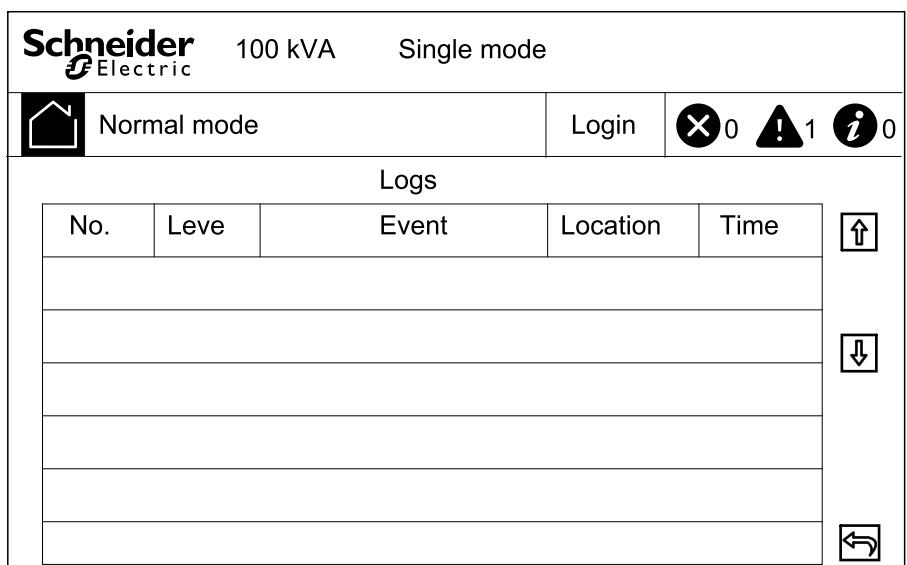

2. You can browse through the list of events using the arrows.

Calibrate the Display

1. Select **Service > Display calibration**.
2. Tap the crosses on the display to complete the calibration.

Schneider Electric
35 rue Joseph Monier
92500 Rueil Malmaison
France

+ 33 (0) 1 41 29 70 00



* 9 9 0 - 5 9 9 5 B - 0 0 1 *

As standards, specifications, and design change from time to time,
please ask for confirmation of the information given in this publication.

© 2019 – 2019 Schneider Electric. All rights reserved.

990-5995B-001