

Tefal®

OptiGrill Elite

FR
NL
DE
EN
IT
ES
PT
EL



Mode d'emploi - Instructies voor gebruik -
Bedienungsanleitung - Instructions for use - Istruzioni d'uso -
Instrucciones de uso - Manual de instruções - Οδηγίες χρήσης

SAFETY INSTRUCTIONS

IMPORTANT SAFEGUARDS

Use, maintenance and product installation guidelines: for your own safety, please read through all paragraphs of the instruction manual including the associated pictograms.

This appliance is intended for indoor, domestic household use only. It is not intended to be used in the following applications, and the guarantee will not apply for:

- staff kitchen areas in shops, offices and other working environments;
- farm houses;
- by clients in hotels, motels and other residential type environments;
- bed and breakfast type environments.

Before first use remove all packaging materials, stickers and accessories from the inside and the outside of the appliance.

This appliance is not intended for use by persons (including children) with reduced physical, sensory or mental capabilities, or lack of experience and knowledge, unless they have been given supervision or instruction concerning use of the appliance by an adult responsible for their safety. Children should be supervised to ensure that they do not play with the appliance, and do not use as a toy.

This appliance can be used by children aged from 8 years and above and persons with reduced physical, sensory or mental capabilities or lack of experience and knowledge if they have been given supervision or instruction concerning use of the appliance in a safe way and understand the hazards involved. Cleaning and user maintenance shall not be made by children unless they are older than 8 and supervised.

Keep the appliance and its cord out of reach of children less than 8 years.

Never leave the appliance unattended when in use.

 Accessible surface temperatures can be high when the appliance is operating. Never touch the hot surfaces of the appliance.

This appliance is not intended to be operated by means of an external timer

or separate remote-control system.

Fully unwind the power cord before plugging in the appliance.

If the power supply cord is damaged, it must be replaced by the manufacturer or its after sales service in order to avoid any danger.

Do not use an extension lead. If you accept liability for doing so, only use an extension lead which is in good condition, has a plug with an earth connection and is suited to the power rating of the appliance. Take all necessary precautions to prevent anyone tripping over an extension cord.

Always plug the appliance into an earthed socket.

Make sure that the electric power supply is compatible with the power rating and voltage indicated on the bottom of the appliance.

Use a sponge, hot water and washing up liquid to clean the cooking plates.

Never immerse the appliance, its power cord or plug in water or any other liquid.

WARNING: Do not heat or pre-heat without the 2 cooking plates inside the grill.

Do

- Read the instructions carefully, common to different models depending on the accessories your appliance with supplied with. Keep the instructions within reach.
- If an accident occurs, rinse the burn immediately with cold water and call a doctor if necessary.
- Before first use, wash the plates (see paragraph 5), pour a little cooking oil onto the plates and wipe with a soft cloth or paper kitchen towel.
- Position the power cord carefully, whether an extension is used or not, so that guests can move freely around the table without tripping over it.
- Cooking fumes may be dangerous for animals which have a particularly sensitive respiratory system, such as birds. We advise bird owners to keep them away from the cooking area.
- Always keep the appliance out of the reach of children.
- Check that both faces of the plate are clean before use.
- To prevent damage to the plates, only use them on the appliance for which they were designed (e.g., do not place in an oven, on the gas ring or electric hot-plate, etc.).
- Ensure that the plates are stable, well positioned and correctly clipped to the appliance. Only use the plates provided with the appliance or bought from an Approved Service Centre.
- Always use a wooden or plastic spatula to avoid damaging the cooking plates.
- Only use parts or accessories provided with the appliance or bought from an Approved Service Centre. Do not use them for other appliances or intention.

Do not

- Do not use the appliance outside.
- Never leave the appliance unattended when plugged in or in use.
- To prevent the appliance from overheating, do not place it in a corner or below a wall cupboard.
- Never place the appliance directly on a fragile surface (glass table, tablecloth, varnished furniture, etc.) or on a soft surface such as a tea-towel.

- Never place the appliance under a cupboard attached to a wall or a shelf or next to inflammable materials such as blinds, curtains or wall hangings.
- Never place the appliance on or near hot or slippery surfaces; the power cord must never be close to or in contact with hot parts of the appliance, close to a source of heat or resting on sharp edges.
- Do not place cooking utensils on the cooking surfaces of the appliance.
- Never cut food directly on the plates,
- Do not use metal scouring pads, abrasive wire wool or harsh scouring powder as this may damage the nonstick coating.
- Do not move the appliance when in use.
- Do not carry the appliance by the handle or metallic wires.
- Never run the appliance empty.
- Do not use aluminium foil or other objects between the plate and the food being cooked.
- Do not remove the grease collection tray while cooking. If the grease collection tray becomes full when cooking: let the appliance cool down before emptying.
- Do not place the hot plate on a fragile surface or under water.
- To preserve the non-stick properties of the coating, avoid excessive pre-heating with the appliance empty.
- The plates should never be handled when hot.
- Do not cook food in aluminium foil.
- To avoid spoiling your appliance, do not use flambé recipes in connection with it at any time.
- Do not place a sheet of aluminum or any other object between the plates and the heating element.
- Never heat or cook whilst the grill is open.
- Never heat up the appliance without the cooking plates.

Tips/information

- Thank you for buying this appliance, which is intended for domestic use only.
- For your safety, this appliance complies with the applicable standards and regulations - Low voltage directive - Electromagnetic compatibility - The environment - Materials in contact with food.
- On first use, there may be a slight odour and a little smoke during the first few minutes.
- Our company has an ongoing policy of research and development and may modify these products without prior notice.
- Do not consume foodstuff that comes into contact with the parts marked with logo .
- If the food is too thick, the safety system will stop the appliance from working.
- The instrument panel is fragile: clean, wipe and dry with a dry, soft cloth only. Do not clean it with a wet sponge as this may damage its functions.

Environment



Environment protection first!

- ① Your appliance contains valuable materials which can be recovered or recycled.
- ➡ Leave it at a local civic waste collection point.

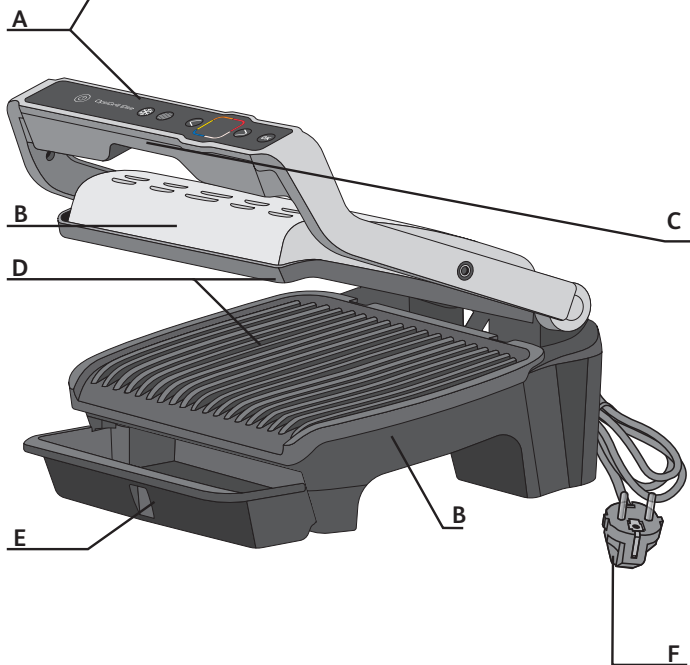
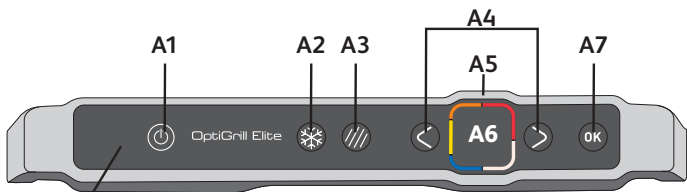

Description

A Control panel

A1 On/Off button

A2 Frozen food function

A3 Searing function

A4 Adjustment and navigation buttons

A5 Preheating indicator and cooking level

A6 Display screen

A7 **OK** button

B Appliance body

C Handle

D Cooking plates

E Drip tray

F Power cord

12 automatic cooking programs

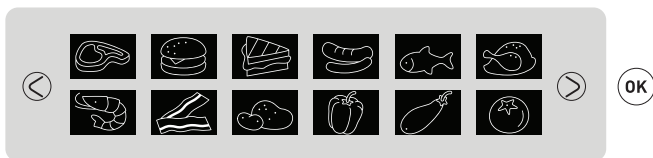

Two additional cooking options in automatic mode



Frozen food function



Searing function

Note: The Frozen food function and Searing function can be used independently or both at the same time.

Manual mode

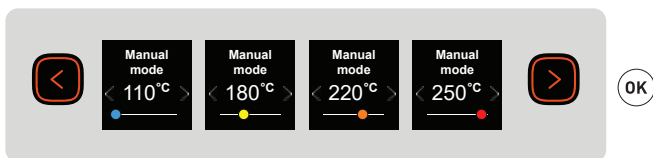

1 Before first use

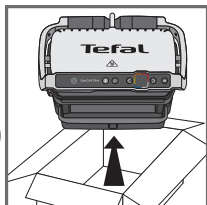
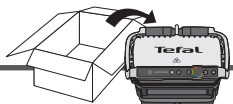

1

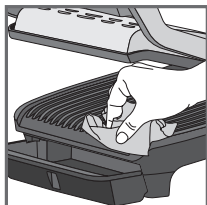

2

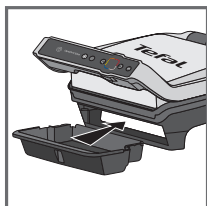

3

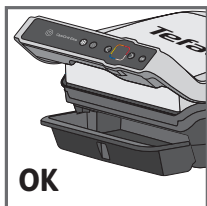

OK

4

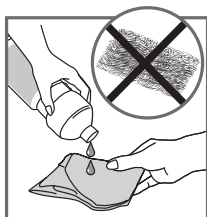

5

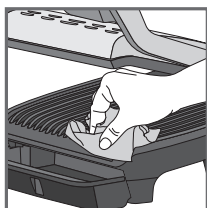

6

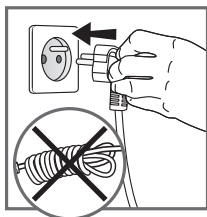

7

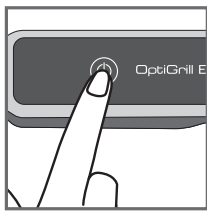

8

1 Remove all packaging, stickers and various accessories from both the inside and outside of the appliance.

2 Prior to first use, thoroughly clean the cooking plates using some hot water and some washing-up liquid, carefully rinse and dry.

3-4 Install the removable drip tray at the front of the machine.

5 If you wish, for best results and to improve the effectiveness of the non-stick surface, you can wipe the cooking plates with a paper towel dipped in a little cooking oil.

6 Remove any excess oil with a clean paper towel.

7 Make sure the top and bottom plates are correctly positioned in the appliance. Do not start preheating without the plates. Connect the appliance to the mains supply. (the cable must be completely unwound).

8 Press the On/Off button.

Caution: Ensure that there is no food between the plates.

2 Using for the first time

- 9 Select your language using the arrows then press ok.



9

3 On/Off button

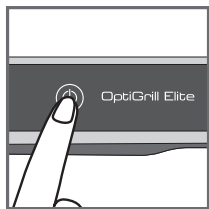

10

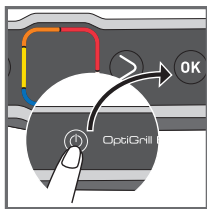

11

- 10 Switch on fig. 10.

- 11 To switch off the grill press once on the On/Off button and once on the OK button to switch off the appliance.

4 Frozen food function in automatic mode only

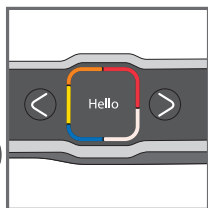

12

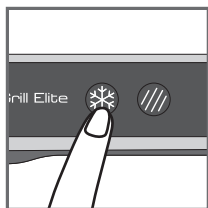

13

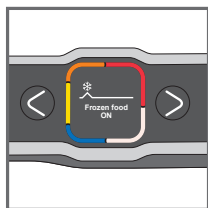

14

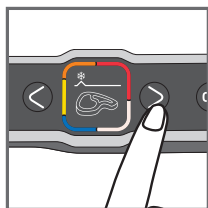

15

13-15 Frozen food function must be activated before starting preheating, if the food to be cooked is frozen/deep frozen.

If you forget to activate the option, turn off the appliance and repeat the steps.

This function is only available in automatic mode, not in manual mode.

5 Searing function in automatic only

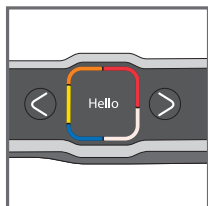

16



17

17-19 Searing function must be activated before starting preheating, if you want significant searing on the food to be cooked.

If you forget to activate the option, turn off the appliance and repeat the steps.

This function is only available in automatic mode, not in manual mode.

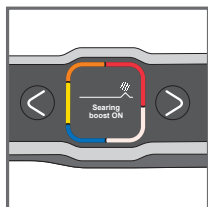

18

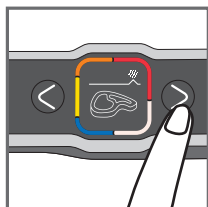

19

6 Cooking in automatic mode

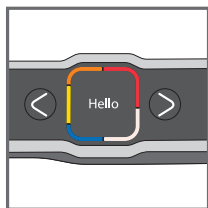

20

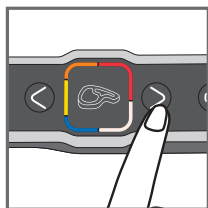

21

- 21** Select the appropriate cooking mode according to the type of food to be cooked.

Note about meat: the cooking results of the pre-defined programs may vary depending on the origin, the cut and the quality of the food to be cooked; the programs having been developed and tested with food of good quality.

Similarly, the thickness of the meat must be taken into account during cooking; you must not cook foods over 4 cm thick.

If you are unsure of which cooking mode to use, please refer to the Cooking Guide, page 89.

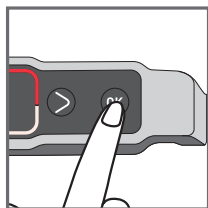

22



23

- 22** Press the **OK** button: the appliance starts to preheat.

Note: if you select the wrong program, switch off the grill and go back to step 8.

- 23** Wait 4 to 7 minutes.

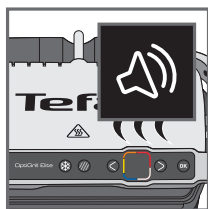

24

- 24** A beep sounds to signal that preheating is finished.

Caution: if the appliance remains closed for too long after preheating is finished, the safety system will turn off the appliance.

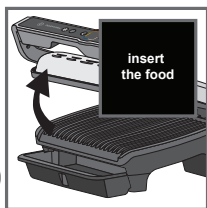

25

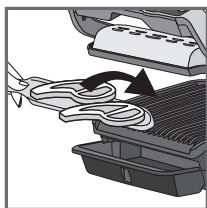

26



27

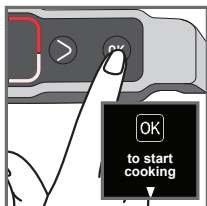

28



29



30



31



32

25-26

Once preheating has finished, you can insert your ingredients. Fully lift the grill lid and place the food on the grill.

Caution: if the appliance remains open for too long, the safety system will turn off the appliance.

27-29

The appliance automatically calculates the cooking cycle (time and temperature) according to the quantity and thickness of the food.

Close the appliance so that the cooking cycle can start.

Note for very thin foods, such as bacon: The "OK" button is on. Then press "OK" again to make sure that the appliance recognises the food and that the cooking cycle starts.

The arrow moves along the cooking level indicator and when it reaches a cooking level, the level is displayed and a beep sounds.

Note: the cooking levels are pre-programmed for each automatic mode.

During cooking, a beep will alert the user each time a cooking level is reached (e.g. rare/yellow).

Depending on the degree of cooking, the indicator changes colour and the cooking progress arrow moves on the screen.

Note, especially for meat, that it is normal for the cooking results to vary according to the type, quality and origin of the food.

31-32 At any time, you can find out the time remaining to reach the different levels of cooking. Press the right arrow if you want to see in how long before the next cooking level is reached. Note that this does not select the cooking levels. The grill continues to cook to the last cooking level and a beep sounds at each level.

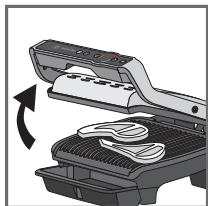

33

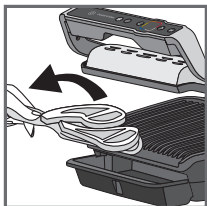

34

33-34 When the cooking level of your choice is reached and the beep sounds, open the appliance and remove your food.

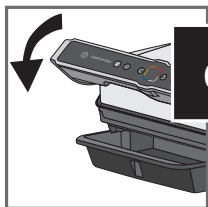

35



36

35-36 Close the lid. The screen asks for your confirmation to stop cooking. Confirm with OK if all foods have been removed, otherwise allow it to continue cooking.

If you wish to cook more food, refer to section 7, page 82.

Note: the safety system will turn off the power automatically if no program is selected after a certain time.

ZE

7 How to cook a second batch

Second batch of the same type of food

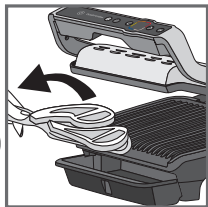

37



38

37-38 At the end of the first cook, an "any refill" screen appears. If you want to grill the same type of food, press OK.

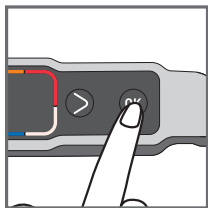

39

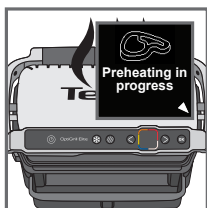

40

39 The appliance starts preheating.
40 Wait until preheating has finished.

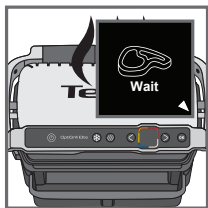

41

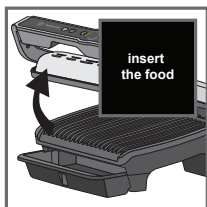

42

41 Put the food on the grill.
42 Then follow steps 26 to 36.

Second cooking with a different type of food

Once cooking your first ingredient has finished:

1. Ensure that the appliance is closed and that there is no food inside.
2. Select the appropriate cooking program or mode.
3. Press the **OK** button to start preheating. During preheating, the preheating indicator is displayed on the screen.
4. Once preheating has finished, a beep sounds and the preheating information is shown on the screen.
5. The appliance is ready to use once preheating has finished. Lift the grill lid and place the food inside the grill. Then follow steps 26-36.

Important:

- Preheating is essential to cooking.

Reminder: before starting preheating, ensure that the appliance is closed and that there is no food inside.

- Wait until preheating is finished before opening the grill and putting food inside.

Note: if the new preheating cycle is started immediately after the end of the previous cycle, the preheating time will be shorter.

8 Cooking in manual mode



43

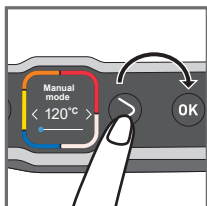

44

- 43 Select manual mode and press OK to confirm.

- 44 Select the desired temperature using the adjustment buttons. Please refer to manual cooking guide page 90.

Press OK to confirm the selected temperature.

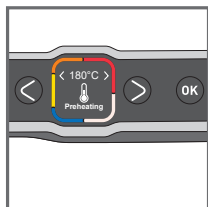

45

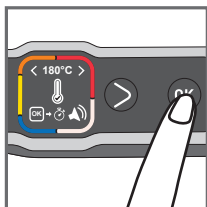

46

- 45 Wait until preheating has finished.

- 46 Once preheating has finished, press OK to start the timer.

Note: the cooking time can also be set from the start of preheating.

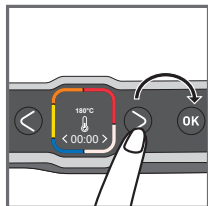

47

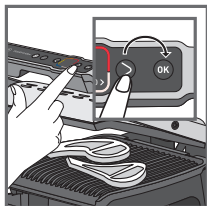

48

- 47 Press the adjustment buttons to select the desired cooking time.

- 48 Insert your food and press OK to start cooking.

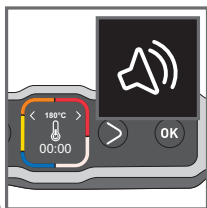

49



50

49-50 A beep sounds to indicate when the cooking time has finished. Remove your food.

Press OK to stop cooking and remove your food.

9 Comments

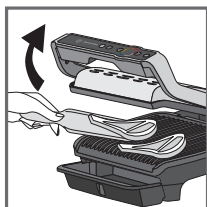

51

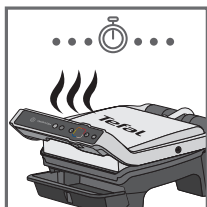

52

51-53

Depending on your personal preferences, open the grill and remove foods that have reached the desired cooking level, then close the grill to continue cooking other foods. The program will continue the cooking cycle until the last cooking level of the selected mode.

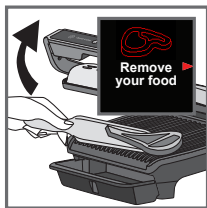

53



54

54 Note: the safety system will turn off the power automatically after a certain time.

10 End of use



55

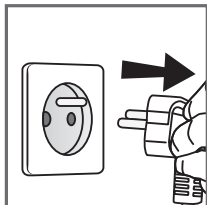

56

55 Press the On/Off button and confirm by pressing the OK button.

56 Unplug the appliance.

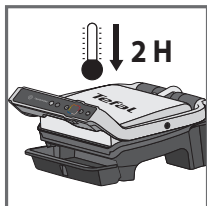

57

57 Let it cool for at least 2 hours.

To prevent accidental burns, allow the grill to cool completely before cleaning.

11 Cleaning

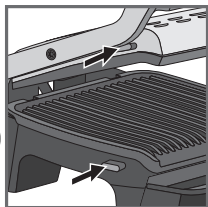

58

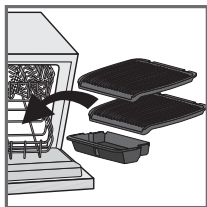

59

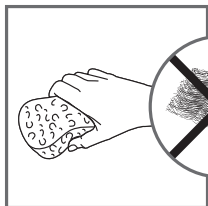

60

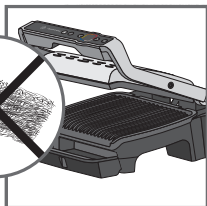

61



62

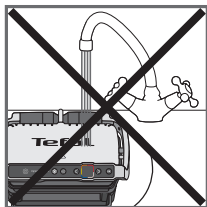

63

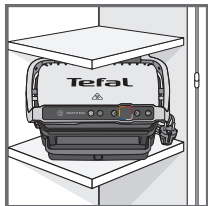

64

58 To unlock the plates, press the release tabs on the left hand side of the appliance. Before cleaning, unlock and remove the plates to prevent damage to the cooking plates.

59 The drip tray and cooking plates are dishwasher safe. The appliance and its power cord must never be put in the dishwasher. If you wash the plates in a dishwasher, always wipe the plates over with a little cooking oil on next use in order to condition the coating and ensure the best performance from the non-stick. The heating elements should never be cleaned after the plates have been removed. If they are very dirty, wait until the appliance has cooled down completely and clean them with a dry cloth.

60-61

If you do not wish to put the plates in the dishwasher, use some hot water and some washing-up liquid to wash them, then rinse thoroughly to remove all residue. Dry them gently with a paper towel.

Do not use metal scouring pads, steel wool or abrasive cleaners to clean any part of the grill or cooking plates, use only nylon or non-metallic cleaning pads suitable for non-stick surfaces.

Empty the drip tray and wash it in warm, slightly soapy water, then wipe it thoroughly with a paper towel.

62 To clean the grill lid, wipe with a sponge moistened with warm water and dry with a soft, dry cloth. To clean the control panel, use only a soft, dry cloth.

63 The appliance must not be submerged in water or in any other liquid.



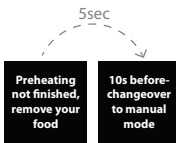

64 Always ensure that the appliance is clean, cold and dry prior to storage. All repairs must be done by an authorised service centre.

Troubleshooting Guide

















OPTIGRILL ELITE TROUBLESHOOTING GUIDE

Problem	Cause	Solution
A change of language		Switch on the grill, press ON, then immediately on the Frozen button (while the screen displays "Hello")
 <p>5sec</p> <p>Preheating not finished, remove your food</p> <p>10s before changeover to manual mode</p>	<p>The preheating time was not completely finished. The grill was opened and the food placed on the plate before the end of preheating.</p>	<p>It is possible to cook the food, but you have to check the cooking progress because the grill is in manual mode.</p> <p>The temperature can be adjusted.</p> <p>Or</p> <p>Open the grill, remove the food, close the grill properly and wait until the end of preheating.</p>
My appliance does not switch off	Missing a second press or too long a time between the 2 presses.	<p>Press the On/Off button twice.</p> <p>Or</p> <p>Press the On/Off button once then press OK</p>
Err 1 to Err 8	<p>The unit has been stored or used in a room that is too cold.</p> <p>Appliance overheating.</p>	<p>Unplug the appliance and wait a few minutes.</p> <p>Plug the grill in again and switch it on.</p> <p>If the problem persists, contact customer services.</p>
Err 9 to Err 13	Appliance failure.	Unplug the appliance and contact customer services.
The appliance shuts down itself during the preheating or cooking cycle.	<p>The appliance remained open for too long during cooking.</p> <p>The unit has been idle for too long after preheating or preheating has finished.</p>	Unplug the appliance and wait a few minutes. Then plug in your appliance again and turn it on.

OPTIGRILL ELITE TROUBLESHOOTING GUIDE

Problem	Cause	Solution
	End of cooking confirmation request	2 solutions: Press OK if all of the food has been removed Or Do not press OK and leave the food to cook a little longer
	Food not detected because it is too thin, for example bacon	Press OK to start cooking
	Food too thick, over 4 cm	2 solutions: Press OK to continue cooking in manual mode Or Remove the food and cut thinner to reduce the thickness, to allow cooking in automatic mode
I cannot set a time in manual mode	The screen is stuck on temperature setting	Press OK once to go to the time setting and then adjust it using the arrows. Press OK to confirm. 

Cooking levels for each automatic program



12 AUTOMATIC PROGRAMS					
AUTOMATIC PROGRAMS		COOKING LEVEL INDICATOR			
MENUS		 Blue	 Rare	 Medium	 Well-done
	Beef	Very rare (Blue)	Rare	Medium	Well done
	Chicken breast*	-	-	-	Well done
	Sausage	-	-	-	Well done
	Bacon**	-	-	Medium	Crispy
	Beef Burger***	-	-	-	Well done
	Panini	-	Lightly cooked	Toasted	Crispy
	Fish	-	Medium	Medium to well-done	Well done
	Seafood	-	Medium	Medium to well-done	Well done
	Potato	-	-	-	Soft
	Pepper	-	-	Crunchy	Soft
	Aubergine	-	-	-	Grilled
	Tomato	-	-	Crunchy	Soft

* For the UK only: do not cook chicken breast from frozen. Always thaw completely first.

** As bacon is a thin food, after closing the lid, press the "OK" button to make sure the appliance recognise the food and the cooking cycle starts.

*** For the UK only: For food safety reasons the Food Standards Agency do not advise serving rare or medium burgers. Only serve well done burgers.

COOKING ADVICE FOR OTHER FOODS

PRODUCTS	COOKING PROGRAM	COOKING TIP
Pork tenderloin (boneless), pork belly		Well done*
Bratwurst (pre-cooked pork)		220°C / 8 min 30 sec
Rindswurst (pre-cooked beef)		220°C / 8 min 30 sec
Nürnberger Wurst (pre-cooked pork)		220°C / 4 min 30 sec

MANUAL MODE

FRUIT OR VEGETABLES

From 180°C to 195°C	From 220°C to 235°C	From 225°C to 270°C
-	-	Courgette (slices)
-	-	Asparagus (whole)
-	-	Mushroom
-	Onion	-
Broccoli florets	-	-
Baby carrot	-	-
-	Fennel	-
Sweet potato (slices)	-	-
-	Apple (slices)	-
-	Banana	-
-	Peach (Stoned and sliced)	-

OPTIGRILL ELITE PREPARATION ADVICE

For more significant searing, it is best to return the grilled food to the grill before serving it to your guests.

PRODUCTS	PREPARATION ADVICE
POTATO	<ul style="list-style-type: none">• Cut lengthways• Coat or brush the potato slices with oil for the best cooking results.
PEPPER	<ul style="list-style-type: none">• Cut in half lengthway and remove seeds
AUBERGINE	<ul style="list-style-type: none">• Cut lengthways• Coat or brush the aubergine slices with oil for the best cooking results.
TOMATO	<ul style="list-style-type: none">• Use round tomatoes• Use tomatoes that are not too ripe• Cut in half widthways• For optimal cooking, place the rounded side of the halved tomato on the bottom plate of the grill.
PORK	* Use the searing function if the thickness is more than 20 mm.

FR	2-24
NL	25-47
DE	48-70
EN	71-91
IT	92-114
ES	115-137
PT	138-160
EL	161-183