

DETAIL A
IEC 309 16A,
200-240VAC,
L+N+PE PLUG
ENLARGED VIEW

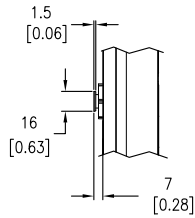

DETAIL B
PEG TOOL LESS MOUNTING
ENLARGED VIEW

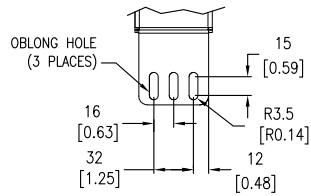

DETAIL C
UNIVERSAL MOUNTING BRACKET
ENLARGED VIEW

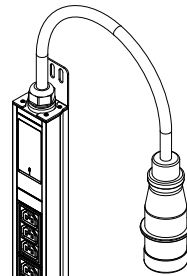

ISOMETRIC VIEW

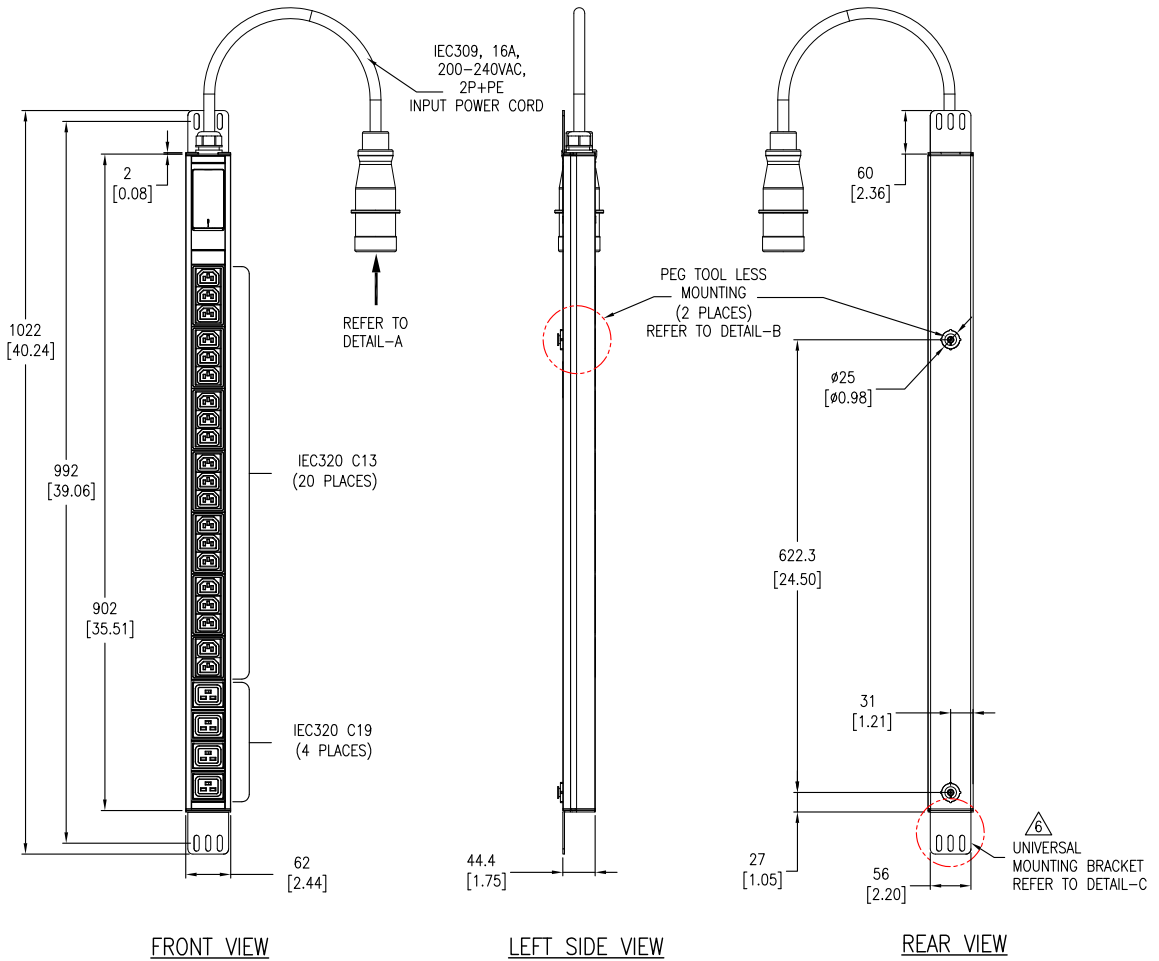

FRONT VIEW

LEFT SIDE VIEW

REAR VIEW

NOTES:

1. INSTALLATION SHALL COMPLY WITH ALL APPLICABLE NATIONAL, STATE AND LOCAL ELECTRICAL CODES.
2. REFER TO PRODUCT DOCUMENTATION FOR ADDITIONAL DETAILS PRIOR TO INSTALLATION AND PREPARATION WORK.
3. UNLESS OTHERWISE SPECIFIED, ALL DIMENSIONS ARE IN MILLIMETERS [INCHES].
4. NET WEIGHT OF UNIT IS 2.2kg [4.85 lb].
5. LENGTH OF THE CORD IS 3000mm [118 Inches].
- △ 6. UNIVERSAL MOUNTING BRACKET IS AN ALTERNATIVE MOUNTING METHOD TO THE TOOL LESS MOUNT FOR 3RD PARTY ENCLOSURES. BRACKET IS PROVIDED WITH THE UNIT.
7. REFER TO WARNING LABEL ON REAR OF UNIT FOR SCREW MOUNTING.

THIS DRAWING AND SPECIFICATIONS HEREIN ARE THE PROPERTY OF SCHNEIDER ELECTRIC AND SHALL NOT BE COPIED, REPRODUCED OR USED IN WHOLE OR IN PART, AS THE BASIS FOR THE MANUFACTURE OR SALE OF ITEMS WITHOUT WRITTEN PERMISSION FROM SCHNEIDER ELECTRIC. THIS DRAWING IS BASED UPON LATEST AVAILABLE INFORMATION AND IS SUBJECT TO CHANGE WITHOUT NOTICE.



TITLE: Easy PDU, Basic
ZERO U, 16A, 230V
INPUT: IEC309, L+N+PE
OUTPUT: (20) IEC320 C13 & (4) IEC320 C19
GENERAL ARRANGEMENT

DWG NO: EPDU1116B REV. 0

DRAWN: JAYAPRAKASH	04-NOV-19	FIRST ANGLE PROJECTION
ENGINEER: Troy LIU	05-NOV-19	
APPROVED: Tong XU	05-NOV-19	

PROJECT: SUBMITTAL DRAWING SHEET 1 OF 2

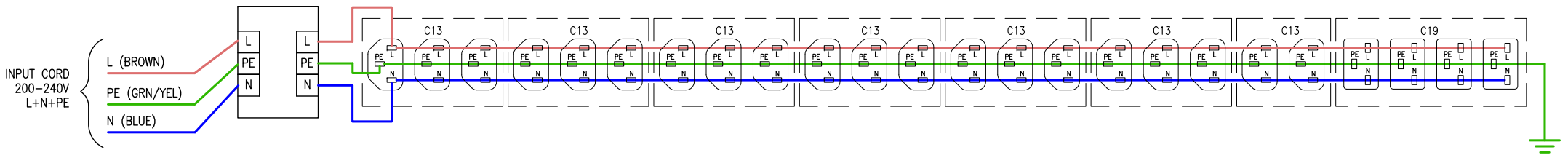

NOTES:

1. INSTALLATION SHALL COMPLY WITH ALL APPLICABLE NATIONAL, STATE AND LOCAL ELECTRICAL CODES.
2. REFER TO PRODUCT DOCUMENTATION FOR ADDITIONAL DETAILS PRIOR TO INSTALLATION AND PREPARATION WORK.
3. THIS DRAWING DEPICTS THE POWER SYSTEM CONNECTIONS AND IS NOT REPRESENTATIVE OF THE PHYSICAL LAYOUT. PLEASE REFER TO MECHANICAL DRAWINGS FOR PHYSICAL LAYOUT.

THIS DRAWING AND SPECIFICATIONS HEREIN ARE THE PROPERTY OF SCHNEIDER ELECTRIC AND SHALL NOT BE COPIED, REPRODUCED OR USED IN WHOLE OR IN PART, AS THE BASIS FOR THE MANUFACTURE OR SALE OF ITEMS WITHOUT WRITTEN PERMISSION FROM SCHNEIDER ELECTRIC. THIS DRAWING IS BASED UPON LATEST AVAILABLE INFORMATION AND IS SUBJECT TO CHANGE WITHOUT NOTICE.



TITLE: Easy PDU, Basic
ZERO U, 16A, 230V
INPUT: IEC309, L+N+PE
OUTPUT: (20) IEC320 C13 & (4) IEC320 C19
SCHEMATIC DIAGRAM

PROJECT: SUBMITTAL DRAWING SHEET 2 OF 2

DWG NO:	EPDU1116B	REV:	0
DRAWN:	JAYAPRAKASH	04-NOV-19	FIRST ANGLE PROJECTION
ENGINEER:	Troy LIU	05-NOV-19	
APPROVED:	Tong XU	05-NOV-19	