

GB

IE

MT

DETAILED INSTRUCTIONS FOR USE OF A GAS FREE STANDING COOKER

gorenje

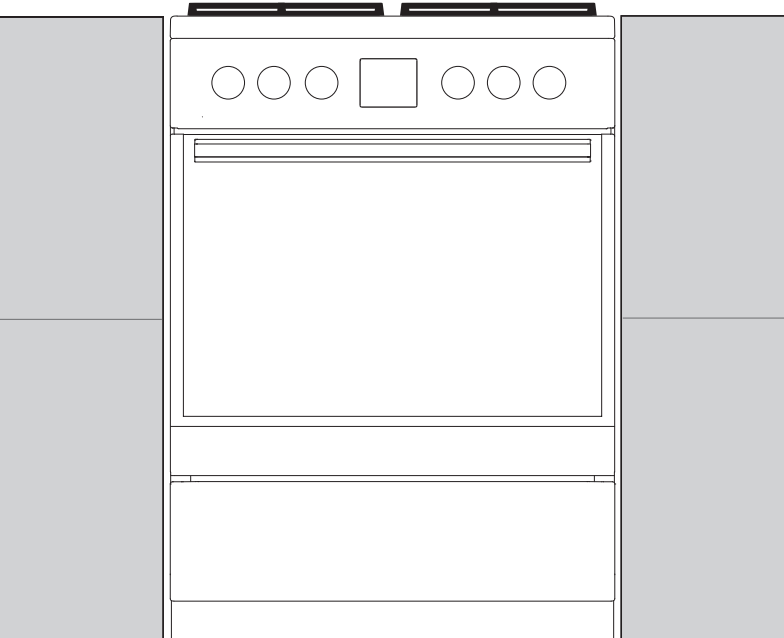

FG6A...

We thank you for your trust and the purchase of our appliance.

This detailed instruction manual is supplied to make the use of this product easier. The instructions should allow you to learn about your new appliance as quickly as possible.

Make sure you have received an undamaged appliance. If you do find transport damage, please contact the seller from which you purchased the appliance, or the regional warehouse from which it was supplied. The telephone number can be found on the invoice or on the delivery note.

These instructions are only valid if the country symbol is printed on the appliance. If there is NO country symbol on the appliance, please consult the technical instructions for adjusting the appliance according to the requirements for use in the relevant country.

The appliance has to be connected in compliance with the effective regulations, and it may only be used in well ventilated areas. Read the instructions before connecting or using the appliance.

Instructions for use are also available at our website:

<http://www.gorenje.com>



Important information



Tip, note

CONTENTS

4 IMPORTANT SAFETY INSTRUCTIONS 8 Before connecting the appliance	INTRODUCTION
9 GAS FREE STANDING COOKER 13 Control unit 14 Appliance data - data plate	
15 USING THE APPLIANCE 15 Before using the appliance for the first time 15 Cooking hob (depending on the model) 16 Electronic program timer 21 Oven 23 Descriptions of cooking systems and cooking table	USING THE APPLIANCE
30 MAINTENANCE & CLEANING 31 Conventional oven cleaning 32 Gas burner 33 Using the aqua clean function to clean the oven 34 Cleaning the insert bottom panel 35 Removing and cleaning wire and telescopic extendible guides 36 Removing and inserting the oven oor 39 Removing and inserting the oven inner door glass (depending on the model) 41 Replacing the bulb	MAINTENANCE & CLEANING
42 SPECIAL WARNINGS AND FAULT REPORTING	TROUBLE-SHOOTING
44 INSTALLATION AND CONNECTION INSTRUCTIONS	INSTALLATION INSTRUCTIONS
50 NOZZLE TABLE	OTHER
52 DISPOSAL	

IMPORTANT SAFETY INSTRUCTIONS



CAREFULLY READ THE INSTRUCTIONS AND SAVE THEM FOR FUTURE REFERENCE

This appliance can be used by children aged from 8 years and above and persons with reduced physical, sensory or mental capabilities or lack of experience and knowledge if they have been given supervision or instruction concerning use of the appliance in a safe way and understand the hazards involved. Children shall not play with the appliance. Cleaning and user maintenance shall not be made by children without supervision.

WARNING: The appliance and its accessible parts become hot during use. Care should be taken to avoid touching heating elements. Children younger than 8 years of age shall be kept away unless continuously supervised.

WARNING: The accessible parts of the appliance may become hot during use. Young children should be kept away from the oven.

The appliance becomes very hot during use. Be careful not to touch the oven heaters.

WARNING: Danger of fire: do not store items on the cooking surfaces.

WARNING: Unattended cooking on a hob with fat or oil can be dangerous and may result in fire. NEVER try to extinguish a fire with water, but switch off the appliance and then cover flame e.g. with a lid or a fire proof blanket.

CAUTION: The cooking process has to be supervised. A short term cooking process has to be supervised continuously.

WARNING: Before replacing the light bulb, make sure the appliance has been disconnected from the mains power, in order to prevent the hazard of an electric shock.

CAUTION: This appliance is for cooking purposes only. It must not be used for other purposes, for example room heating.

The appliance is not intended to be controlled by external timers or separate remote control system.

WARNING: Use only hob guards designed by the manufacturer of the cooking appliance or indicated by the manufacturer of the appliance in the instructions for use as suitable or hob guards incorporated in the appliance. The use of inappropriate guards can cause accidents.

WARNING: If the surface is cracked, switch off the appliance to avoid the possibility of electric shock.

For appliance connection use a 5 x 1,5 mm² cord with mark H05VV-F5G1,5 or better. Cord must be installed by service agent or similar qualified person.

The appliance is intended to be placed directly on the floor, without any supports or plinths.

Do not use harsh abrasive cleaners or sharp metal scrapers to clean the oven door glass or the glass of hinged lids of the hob (where appropriate), since they can scratch the surface, which may result in shattering of the glass.

The appliance must not be installed behind a decorative door in order to avoid overheating.

Do not use steam cleaners or high-pressure cleaners to clean the appliance, as this may result in an electric shock.

If the supply cord is damaged, it must be replaced by the manufacturer, its service agent or similarly qualified persons in order to avoid a hazard.



- CAUTION: possibility of tilting.



- WARNING: In order to prevent tipping of the appliance, stabilising means must be installed. Refer to the instructions for installation.

Only use the temperature probe recommended for this oven.

Make sure the lid is clean and that there is no liquid spilt on it before raising it. The lid may be lacquer-coated or glass. It may only be closed when the cooking zones have completely cooled down.

Appliance must be connected to fixed wiring which is in accordance with the wiring rules.

Appliance must be connected to fixed wiring which has incorporated means of disconnection. Fixed wiring must be made in accordance with the wiring rules.

The appliance is intended for household

use. Do not use it for any other purpose, such as room heating, drying of pets or other animals, paper, fabrics, herbs etc. As this may lead to injury or fire hazard.

The appliance may only be connected by an expert authorized by the gas distribution company or an authorized service center. All relevant legislation and local gas distributor's technical conditions for connection to the gas mains should be complied with.

Unauthorized service and repair can result in risk of explosion, electric shock, or short circuit and consequently personal injury and damage to the appliance.

Such tasks may only be carried out by an authorized expert.

Before installing and connecting the appliance, make sure the local connection conditions and characteristics (gas type and pressure) are compatible with the appliance set-up.

The set-up of the appliance is specified on the rating plate.

This appliance is not connected to a combustion products evacuation device.

It shall be installed and connected in accordance with current installation regulations. Particular attention shall be given to the relevant requirements regarding ventilation.

This is a class 2/1 appliance. The appliance may touch the adjacent cabinets on both sides when placed in a row. On one side, a tall cabinet – taller than the appliance – may be placed at a distance of at least 10 cm from the appliance. On the other side, only a cabinet of the same height may be placed.

Pay attention to correct placement of the burner parts.

Do not install the appliance near powerful sources of heat, such as solid fuel stoves, because high temperature near them can damage the appliance.

Close the main inlet valve if you do not intend to use the burners for a longer period of time (e.g. before going on vacation).

Appliance operation is safe with and without tray guides.

If the **power cord** is damaged, it should be replaced by the manufacturer or an authorized service technician, in order to avoid hazard.

If you observe any faults on the gas installation or smell gas in the room:

- immediately shut off the gas supply or close the gas cylinder;
- put out any open fire and extinguish any tobacco product;
- do not switch on any electrical appliances (including lights);
- thoroughly ventilate the room – open the windows;
- immediately inform the service centre or an authorized natural gas distributor.

Do not line the oven walls with aluminium foil and do not place baking trays or other cookware on the oven bottom. Aluminium foil would prevent air circulation in the oven, hinder the cooking process, and ruin the enamel coating.

Oven door become very hot **during operation**. A third glass is installed for extra protection, reducing the temperature of the outside surface (only with some models).

Oven door hinges may be damaged when under excessive load. Do not place heavy pans on open oven door and do not lean against open oven door when cleaning the oven cavity.

Never stand on the open oven door and do not let children sit on it.

Make sure the vents are never covered or obstructed in any other way.

CAUTION: The use of a gas cooking appliance results in the production of heat, moisture and products of combustion in the room in which it is installed. Ensure that the kitchen is well ventilated especially when the appliance is in use: keep natural ventilation holes open or install a mechanical ventilation device (mechanical extractor hood).

Prolonged intensive use of the appliance may call for additional ventilation, for example opening of a window, or more effective ventilation, for example increasing the level of mechanical ventilation where present.

The appliance is heavy. For carrying the appliance at least 2 persons are needed.

BEFORE CONNECTING THE APPLIANCE



Carefully read the instructions for use before connecting the appliance. Repair or any warranty claim resulting from incorrect connection or use of the appliance shall not be covered by the warranty.

GAS FREE STANDING COOKER

DESCRIPTION OF THE APPLIANCE AND EQUIPMENT

(depending on the model)

Since the appliances for which these instructions were drawn up may have different equipment, some functions or equipment may be described in the manual that may not be present in your appliances.

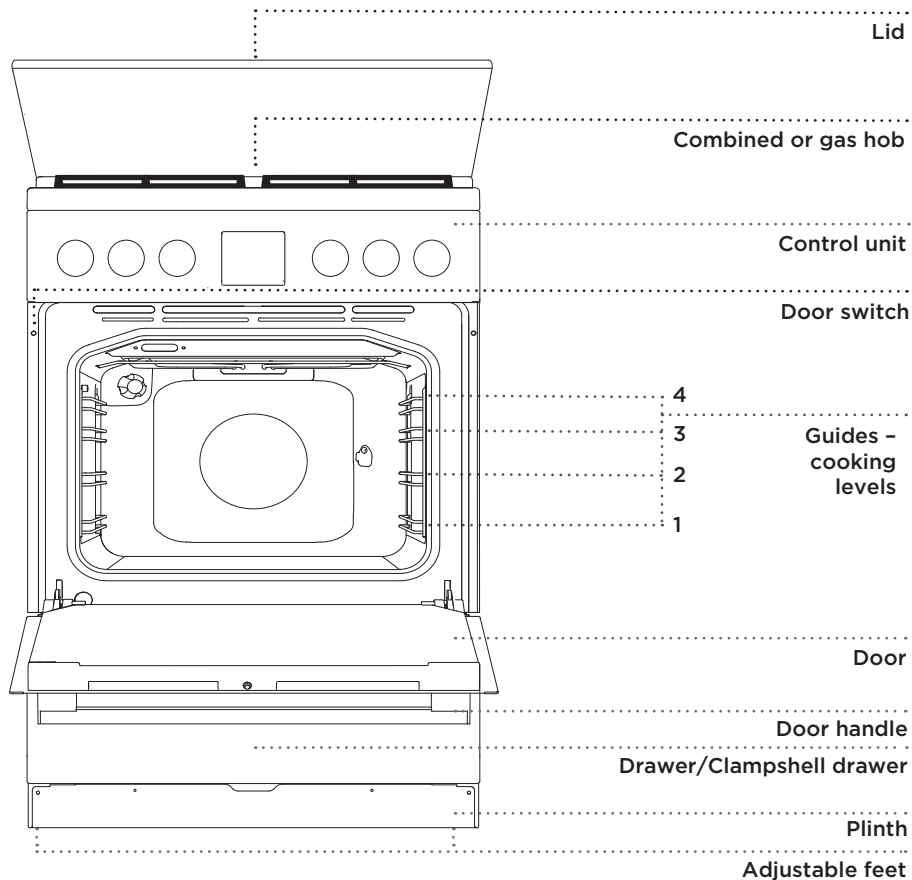

APPLIANCE LID

Make sure the lid is clean and that there is no liquid spilt on it before raising it. The lid may be lacquer-coated or glass. It may only be closed when the cooking zones have completely cooled down.



The symbol on the product or its packaging indicates that glass lids may shatter when heated. Turn off all the burners before shutting the lid.

APPLIANCE DRAWER



Do not store combustible, explosive, volatile or temperature-sensitive items (such as paper, dish cloths, plastic bags, cleaners or detergents and spray cans) in the oven's storage drawer, as they can ignite during excessive operation and cause a fire.

CONTROL LIGHT

The **red light** is on when the oven heaters are activated. When the selected temperature is reached, the red light is switched off.

Oven lighting will be switched on automatically when the cooking system is selected.

WIRE GUIDES

The wire guides allow preparation of the food on four levels.

TELESCOPIC PULL-OUT GUIDES

Telescopic pull-out guides may be fitted for the 2nd, 3rd, and 4th level.

Pull-out guides can be partly or fully extendible.

EMBOSSSED GUIDES

The oven has stamped side grooves in three levels for inserting of the grid.

OVEN DOOR SWITCH

The switch deactivates oven heating and the fan when the oven door is opened during the cooking process. When the door is closed, the switch turns the heaters back on.

COOLING FAN

The appliance is fitted with a cooling fan that cools the housing and the appliance control panel.

After the oven is switched off, the cooling fan continues to operate for a short while in order to cool the oven.

OVEN EQUIPMENT AND ACCESSORIES

(depending on the model)

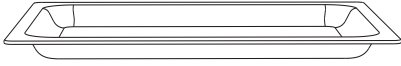

GLASS BAKING DISH is used for cooking with all oven systems. It can also be used as a serving tray.



The **GRID** is used for grilling or as support for a pan, baking tray or baking dish with the food.



There is a safety latch on the grid. Therefore, lift the grid slightly at the front when pulling it out from the oven.

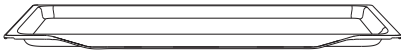

The **SHALLOW BAKING SHEET** is used for baking pastry and cakes.

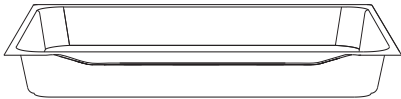

Use the **BAKING TRAY** for cooking of all types of meat, fish and vegetables, as well as for catching the drippings when cooking on the wire rack.



Never place the deep baking tray in the first guide during the cooking process, except when grilling food or using the roasting spit and you are only using the deep tray as a drip tray.



As baking accessories heat up, their form may change. This does not affect their functionality and their original form will be restored when they cool down.

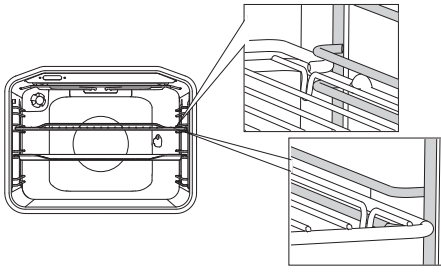

The grid or the tray should always be inserted into the groove between the two wire profiles.

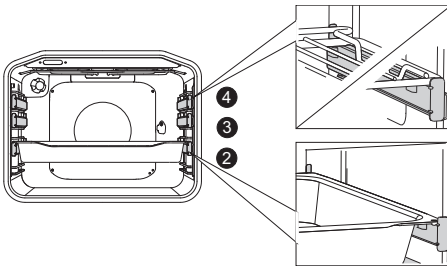

With telescopic extendible guides, first pull out the guides of one level and place the grid or the baking tray onto them. Then, push them in with your hand as far as they will go.

 Close the oven door when the telescopic guides are retracted all the way into the oven.



The **TURNSPIT** (meat skewer) is used for roasting meat. The set consists of a skewer support, skewer with screws, and a removable handle.



The appliance and some of the accessible parts tend to heat up during cooking. Use oven mitts.

CONTROL UNIT

(depending on the model)

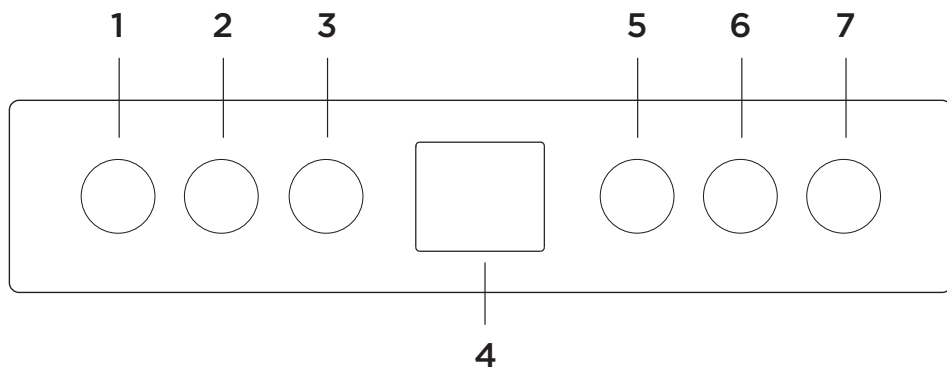

- 1 COOKING ZONE KNOB, FRONT LEFT
- 2 COOKING ZONE KNOB, REAR LEFT
- 3 CONTROL LIGHT
- 4 TIMER
- 5 COOKING SYSTEM SELECTOR KNOB
- 6 COOKING ZONE KNOB, REAR RIGHT
- 7 COOKING ZONE KNOB, FRONT RIGHT

NOTE:

Symbols of cooking systems may be located on the knob or on the front panel (depending on the appliance model).

The keys will respond better if you touch them with a larger area of your fingertip. Each time you press a key, a short acoustic signal will be sounded.

APPLIANCE DATA - DATA PLATE

(depending on the model)

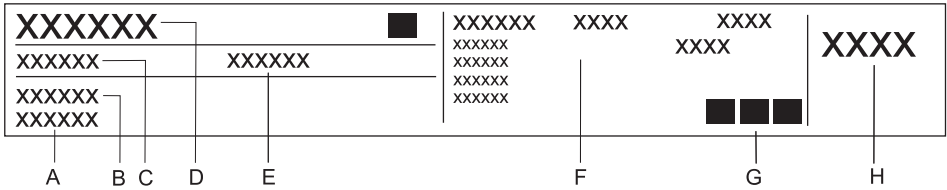

- A Serial number
- B Model
- C Type
- D Trademark
- E Code
- F Technical information
- G Compliance indications / symbols
- H Factory settings for gas type

The rating plate, indicating the basic information about the appliance, is located on the edge of the oven and it is visible when the oven door is opened.

USING THE APPLIANCE

BEFORE USING THE APPLIANCE FOR THE FIRST TIME

Upon receiving the appliance, remove all parts, including any transport equipment, from the oven.

Clean all accessories and utensils with warm water and regular detergent. Do not use any abrasive cleaners.

When the oven heats up for the first time, the characteristic smell of a new appliance will be emitted. Ventilate the room thoroughly during the first operation.

After you receive your appliance, please wipe the entire cooking hob, including the cooking zones, with a damp cloth



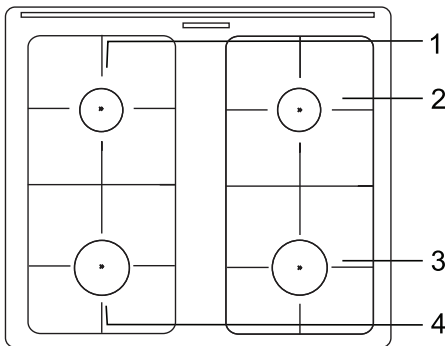

COOKING HOB (depending on the model)

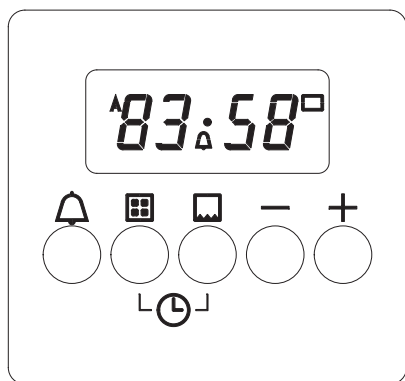

1. Cooking zone rear left
2. Cooking zone rear right
3. Cooking zone front right
4. Cooking zone front left

ELECTRONIC PROGRAM TIMER



-  Minute minder
-  Selecting the right cooking zone gas burner
-  Selecting the oven gas burner
-  Minus
-  Plus

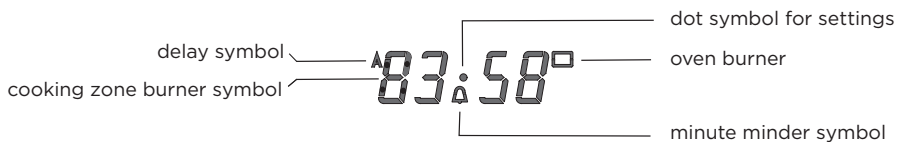

SWITCHING ON AND SETTINGS

After connecting your appliance to the mains power or after an extended power outage, "0.00" will appear on the display.

Setting the time





Touch the  and  keys. Then, use the  and  keys to set the time. The dot symbol will stop flashing and the clock will start running.



 If you press and hold the value adjustment key, the speed at which the set value is being changed will increase.

TIMER FUNCTIONS

Setting the duration of cooking zone burner operation.

With this function, you can simultaneously set different duration of all four gas burners.



Touch the  key to select the burner. The  symbol and the selected burner symbol will flash. Use the  and  key to set the time. (After a few seconds, other burner symbols will go off, and only the  symbol and the selected burner symbol will stay lit.) The time of day will appear. Cooking time (or burner operation time) countdown will start.

 Touch the  key again to set the time for the next burner, change the already active timer setting, or check the remaining time.



When the time expires, the burner is switched off and gas supply to the burner is shut down. A short beep will be heard.

Cancelling a timer setting







Use the  key to select the burner. Then, use the  key to set the time to "0.00". In this case, the burner will continue to operate without any timer setting.

Setting the oven gas burner timer

Use this function to set the duration of cooking only for the lower oven burner.



No timer setting is possible for the infrared burner.

Touch the  key. "0.00" will appear on the display, and the  and  symbols will flash. Use the  and  key to set the time. A few seconds after the time is set, the  and  symbols are lit. Cooking time (or burner operation time) countdown will start.





Touch the  key again to adjust the time or check the remaining time.





When the time expires, the burner is switched off and gas supply to the burner is shut down. A short beep will be heard.

Cancelling a timer setting

Use the  key to select the oven burner. Then, use the  key to set the time to "0.00". In this case, the burner will continue to operate without any timer setting.





Maximum duration that can be set for gas burners and the oven burner is 3 hours.

The  burner symbol indicates that a timer setting is active for at least one of the burners. To check, press the  key.

If the  symbol is lit, then the timer is set for the oven burner (in this case, the symbol  is lit as well).

Setting the minute minder

The minute minder can be used independently from the oven operation. Press the  key. "0.00" appears on the display and the symbol flashes. Use the **—** and **+** key to set the time. After a few seconds the symbol will stop flashing and the timer countdown will start. During the last minute, the minute minder is displayed in seconds. Clock will appear on the display. Press the  key, check the remaining time and adjust it using the **—** and **+** keys. When the time expires, a short acoustic signal is sounded and the symbol turns off.

SELECTING ADDITIONAL FUNCTIONS/EXTRAS

Acoustic signal volume



Set the signal volume when no timer function is activated.

Choose between three different acoustic signal settings. Touch and hold the **—** key. The acoustic signal is sounded at the first level. When the key is released and pressed again, the following volume level is played. The most recently heard acoustic signal volume will be saved.

Safety shut-off function

This function restricts appliance operation time to 3 hours. This time starts counting down after the most recent press of the electric ignition knob or key for any gas burner. Every time the electric ignition is activated, a brief acoustic signal is sounded on the timer.

Using the timer in combination with oven or burners

When using the timer in combination with the oven, first turn the oven "ON" and set the desired cooking system and temperature. Then, set the timer functions. When the food is done, turn off the oven and the cooking zones.

GAS BURNERS

- To sear the food, set the burner to maximum power first, and then continue to cook at minimum power.
- Always place the burner cap accurately on the burner crown. Make sure the slots in the burner crown are never blocked.

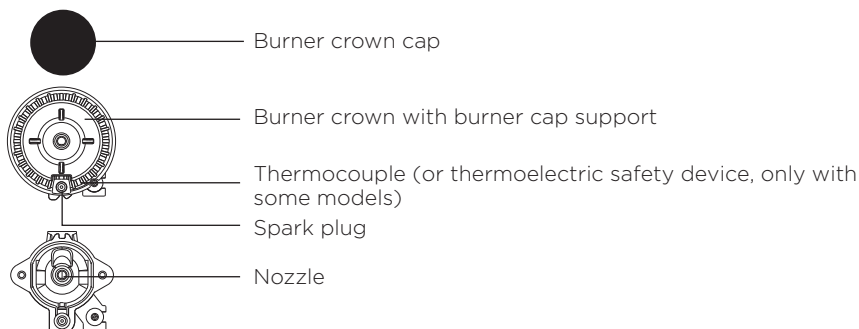

TIPS REGARDING YOUR COOKWARE

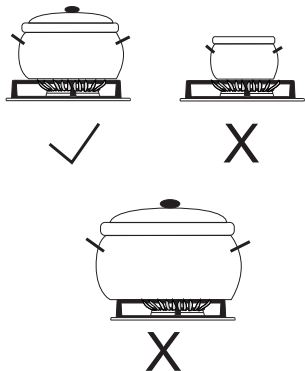

- Correct choice of cookware allows optimum cooking time and gas consumption. Cookware diameter is the most important in this respect.
- If a pot or a pan is too small, the flames reaching over the edge of its bottom will damage it. Moreover, gas consumption will be higher.
- Combustion of gas also requires air. If the pot or pan is too large, there is not enough air and the burning efficiency is decreased.

Gas hob reducer (only with some models) Use the gas hob reducer when cooking in a container of smaller diameter. Place it on the grid over the auxiliary burner.



Burner type	Container diameter
Large (3.0 kW)	220–260 mm
Normal (1.9 kW)	160–220 mm
Auxiliary (1.9 kW)	120–140 mm
Multi-ring burner (3,5kw)	220–260 mm



BURNER IGNITION AND OPERATION

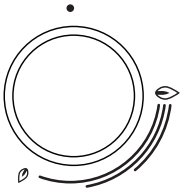

Always press the knob before rotating it.



Cooking power levels are indicated on the knobs with a large and a small flame symbol. Rotate the knob over **the large flame** position  to **the small flame** position  and back. Operating range is between the two flame symbols.

Settings between  and  are not recommended. In this range, the flame is unstable and may be extinguished.



Place the pot or pan on the grid above the burner before igniting it (applies to three-ring, double-ring, and mini-wok burner). To turn off a burner, rotate the knob to the right to position .

Single-handed ignition



To ignite a gas burner, press the corresponding knob and rotate it to the maximum power position. Electric spark from the spark plug will be activated and the gas will ignite.

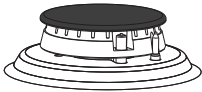

Two-handed ignition

To ignite a gas burner, press the corresponding knob and rotate it to the maximum power position. **Press the spark plug button.** Electric spark from the spark plug will be activated and the gas will ignite.



Electric ignition will only work if the power cord is connected to the mains power. If electric ignition does not work due to a power supply failure or damp spark plugs, the gas can still be ignited with a match or a lighter. After ignition, keep the knob depressed for approximately 10 more seconds until the flame is stabilized.



If the burner does not ignite in 15 seconds, close it and wait for at least 1 minute. Then repeat the ignition process.

If the flame on a burner is extinguished (regardless of the reason), close the burner and wait for 1 minute before trying to ignite it again.

OVEN

CHOOSING THE COOKING SYSTEM

(depending on the model)

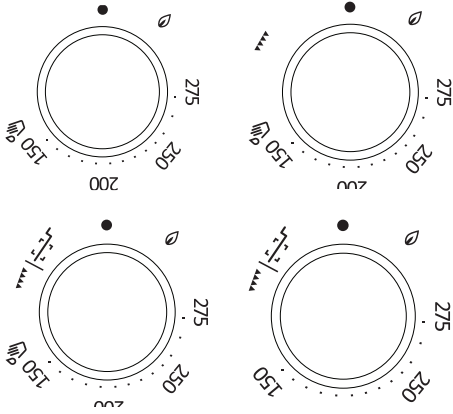

Rotate the knob (left and right) to select the cooking system (see program table).

 Settings can also be changed during operation.

CONVENTIONAL OVEN HEATING WITH GAS

Press the knob and rotate it to the left to position . At the same time, press the ignition device knob or hold a lit match to the oven burner ignition opening until the gas is ignited. When the flame settles, set the desired heating power between 150 and 275 °C.

 After ignition, keep the knob depressed for 10 more seconds until the flame is stabilized.

 Oven temperature is regulated by a thermostat. Immediately after ignition, the burner operates with maximum power until the set temperature is reached. Then, the thermostat automatically reduces the burner power to the level required to maintain the set temperature. Temperature regulation will only work correctly if the oven door is closed.

▼▼▼ HEATING THE OVEN WITH THE INFRARED HEATER

The heat is radiated by the infrared (grill) heater installed in the oven ceiling. It is used for grilling.

- Gas oven

Press the knob and rotate it to the right to position ▼▼▼. At the same time, press the ignition device knob or hold a lit match to the oven burner ignition opening until the gas is ignited.



After ignition, keep the knob depressed for 10 more seconds until the flame is stabilized.



The grill works always on at its nominal heat input.



Infrared heater operation is not controlled by the thermostat, therefore, it operates with full power.

- Electric oven

Press and rotate the knob. Grilling temperature is around 240 °C. When this temperature is reached, the heater is switched off and it is activated again when the temperature drops to below 240°C.



During the ignition of the infrared burner keep the oven door open. After two minutes, close the oven door. Continue cooking with the infrared burner with the oven door closed. When using the infrared heater, keep the oven door closed.

STARTING THE COOKING PROCESS

Set the cooking system; then, switch it on.

SWITCHING OFF THE OVEN

Turn the COOKING SYSTEM SELECTOR KNOB to position ●.

DESCRIPTIONS OF COOKING SYSTEMS AND COOKING TABLE

If your desired food cannot be found in the cooking table, find information for similar food. The information displayed applies to cooking on a single level.

An interval of suggested temperature is indicated. Start with a lower temperature setting and increase it if you find the food is not browned sufficiently.

Only preheat the oven if required by the recipe in the tables in this instruction manual. Heating an empty oven consumes a lot of energy. Hence, baking several types of pastry or several pizzas successively will save a lot of energy, as the oven will already be preheated.

Use dark, black silicon-layered or enamel-coated baking sheets and trays as they conduct the heat very well.

When using parchment paper, make sure it is resistant to high temperatures.

When cooking larger chunks of meat or pastry, a lot of steam will be generated inside the oven, which in turn may condense on the oven door. This is a normal phenomenon which will not affect the operation of the appliance. After the cooking process, wipe the door and the door glass dry.

Switch off the oven approximately 10 minutes before the end of the cooking process to save energy by making use of the accumulated heat.

Do not cool the food in a closed oven to prevent condensation (dew).

Standard doneness levels and recommended final core temperature for different types of meat

Type of food	Food core temperature (°C)	Meat colour on cross-section, and colour of juices
BEEF		
Rare	40-45	meaty red, like raw meat, little juice
Medium rare	55-60	light red, a lot of light red juice
Medium	65-70	pink, small amount of pale pink juice
Well done	75-80	evenly greyish brown, little colourless juice
VEAL		
Well done	75-85	red-brown
PORK		
Medium	65-70	light pink
Well done	75-85	yellow-brown
LAMB		
Well done	79	grey, pinkish juice
MUTTON		
Rare	45	meaty red
Medium rare	55-60	light red
Medium	65-70	pink in the middle
Well done	80	grey
GOAT MEAT		
Medium	70	pale pink, pink juices
Well done	82	grey, juices only slightly pink
POULTRY		
Well done	82	light grey
FISH		
Well done	65-70	white to grey-brown



BOTTOM HEATER

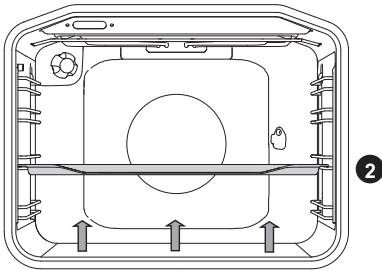

Only the bottom heater will operate.

Baking pastry:

Only use one level and light-coloured baking sheets or trays. Dark baking sheets or trays absorb too much of the heat from the oven burner.

Always place the baking trays on the grid. If you are using the supplied baking sheet, remove the grid. Cooking time will be shorter if the oven is preheated.

Type of food	Guide (from the bottom)	Temperature (°C)	Cooking time (min)
PASTRY IN MOULDS, TINS OR PANS			
Sponge cake *	2	190-200	30-40
Sponge roll*	2	210-220	15-20
Cake / sweet bread (yeast dough)	2	180-190	60-75
Cake (sponge)	2	190-200	20-30
Marble cake	2	180-190	50-60
Jelly-filled rolls (Buchtel)	2	190-200	25-35
Apple pie	2	180-190	40-50
Cheesecake	2	180-190	70-80
Apple and cottage cheese strudel	2	190-200	60-70
SMALL PASTRIES			
Pressed cookies*	2	170-190	20-35
Shortcrust biscuits	2	190-200	15-30
Small cupcakes	2	190-200	30-45
Small pastries, leavened dough	2	200-210	30-40
Phyllo pastry	2	190-200	25-35
Cream-filled pastry	2	200-220	25-45

Type of food	Guide (from the bottom)	Temperature (°C)	Cooking time (min)
BREAD			
Bread *	2	190-200	40-50
Bread rolls (Semmel)*	2	190-200	30-40
Pizza *	2	200-220	30-45

The symbol * means that the oven should be preheated using the selected cooking system.

Roasting meat:

Use enamel coated, tempered glass, clay, or cast iron pan or tray. Stainless steel trays are not suitable as they strongly reflect the heat.

Provide enough liquid during the cooking process to prevent the meat from burning. Turn the meat during cooking. The roast will remain juicier if you cover it.

Type of food	Weight (g)	Guide (from the bottom)	Temperature (°C)	Cooking time (min)
Beef roast	1500	2	190-210	110-140
Pork roast	1500	2	200-210	110-130
Pork roulade	1500	2	200-210	120-140
Meat loaf	1500	2	210-220	50-70
Veal roast	1700	2	180-200	110-130
Lamb sirloin	1500	2	190-200	50-70
Game roast	1500	2	190-200	100-120
Chicken	1500	2	210-220	80-100
Duck	1700	2	180-200	120-140
Goose	3000	2	160-180	180-200
Turkey	4000	2	150-160	180-240



Do not insert the deep baking tray into the first guide.

Soufflés, gratins, and vegetable dishes

Type of food	Guide (from the bottom)	Temperature (°C)	Cooking time (min)
Baked potatoes, chunks	2	200-210	50-70
Vegetables au gratin	2	200-210	50-60
Lasagne	2	200-210	60-70
Moussaka	2	190-200	50-60
Sweet soufflé	2	200-210	40-50
Fish soufflé	2	180-200	46-65

Frozen food

Type of food	Guide (from the bottom)	Temperature (°C)	Cooking time (min)
French fries	2	200-220	20-35
Potato croquettes	2	200-220	20-35
Pizza	2	200-220	20-30
Apple and cottage cheese strudel	2	190-200	60-75
French croissants	2	190-200	20-30



GRILL (INFRARED) HEATER

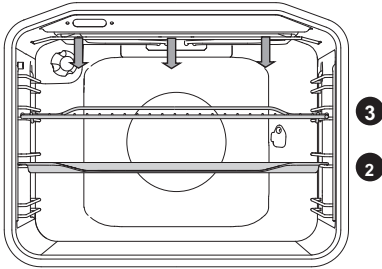

Grill (infrared) heater located at the top of the oven cavity will operate.

Grilling

Type of food	Weight	Guide (from the bottom)	Cooking time (min)
MEAT AND FISH			
Beef steak	180 g/piece	3	25-35
Pork fillets	150 g/piece	3	25-35
Grill sausages	70 g/piece	3	18-23
Meat patties	120 g/piece	3	25-30
Chicken thighs	150 g /piece	3	35-45
Whole fish	200 g/piece	3	18-23
Fish fillets	100 g/piece	3	15-20
Salmon steaks/fillets	200 g/piece	3	20-30
1 chicken, halved	1500 g	2	60-80
TOASTED BREAD			
Toast		3	2-4
Open sandwiches		3	3-5

Preheat the infrared (grill) heater for five minutes.

Supervise the cooking process at all times. The meat may burn quickly due to high temperature.

Roasting with the grill heater is appropriate for crispy and low-fat cooking of bratwurst, cuts of meat and fish (steaks, escalopes, salmon steaks or fillets etc.) or toasted bread. When grilling directly on the grid, smear it with oil to prevent the meat from sticking onto it and insert it into the 3rd guide. Insert the drip tray in to the 1st or 2nd guide.

When grilling in a baking tray, make sure there is enough liquid in the tray to prevent burning. Turn the meat during cooking.

After grilling, clean the oven, the accessories, and the utensils.

Cooking with the turnspit (depending on the model)



Maximum temperature when using the rotisserie is 230°C.

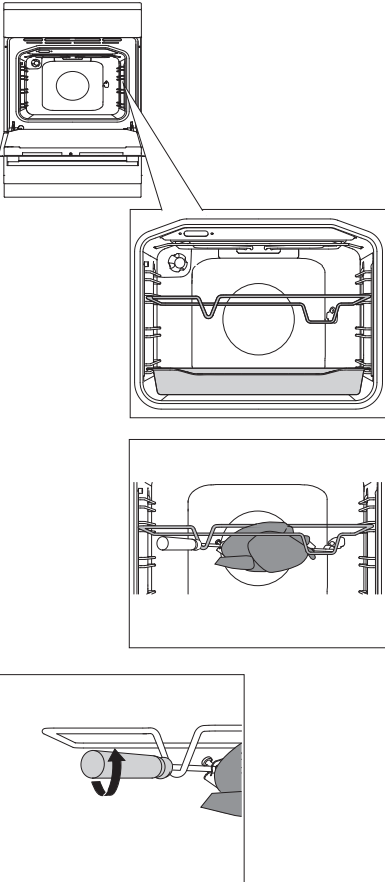

1 Insert the skewer support into the 3rd guide from the bottom and place the deep tray into the bottom (1st) guide to serve as a drip tray.

2 Impale the meat on the skewer and tighten the screws.

Place the skewer handle on the front skewer support and insert the tip into the opening in the right hand side of the rear oven cavity wall (the opening is protected with a rotating cover).

3 Undo the skewer handle and close the oven door.

Switch the oven "ON" and select the system grill heater and spit roast (rotisserie)



Do not use the grill on position 4.

MAINTENANCE & CLEANING



Be sure to unplug the appliance from the power supply and wait for the appliance to cool down.

Children should not clean the appliance or perform maintenance tasks without proper supervision.

Aluminium finish

Clean the aluminium finish with non-abrasive liquid cleaners intended for such surfaces. Apply the cleaner onto a wet cloth and clean the surface. Then, rinse the surface with water. Do not apply the cleaner directly onto the aluminium finish.

Do not use abrasive cleaners or sponges.

Note: The surface should not come into contact with oven cleaning sprays as this may result in visible and permanent damage.

Stainless steel sheet front side of the housing

(depending on the model)

Clean this surface only with a mild detergent (soapsuds) and a soft sponge that will not scratch the finish. Do not use abrasive cleaners or cleaners containing solvents as they may damage the housing finish.

Lacquer-coated surfaces and plastic parts

(depending on the model)

Do not clean the knobs and buttons, door handles, stickers, and rating/type plates with abrasive cleaners or abrasive cleaning materials, alcohol-based cleaners, or with alcohol. Immediately remove any stains with a soft non-abrasive cloth and some water, in order to avoid damaging the surface.

You may also use cleaners and cleaning materials intended for such surfaces as instructed by their respective manufacturers.



The aluminium-coated surfaces should not come into contact with oven cleaning sprays as this may result in visible and permanent damage.

CONVENTIONAL OVEN CLEANING

You may use the standard cleaning procedure to clean stubborn dirt in the oven (using cleaners or an oven spray). After such cleaning, rinse the cleaner residues thoroughly.

Clean the oven and the accessories after each use to prevent the dirt from burning into the surface. The easiest way to remove fat is by using warm soapsuds while the oven is still warm.

With stubborn dirt and grime, use conventional oven cleaners. Rinse the oven thoroughly with clean water to remove all cleaner residue.

Never use aggressive cleaners, abrasive cleaners, abrasive sponges, stain and rust removers etc.

Clean the accessories (baking sheets and trays, grids etc.) with hot water and detergent.

The oven, the oven cavity and the baking trays are lined with a special enamel coating for a smooth and resistant surface. This special coating makes cleaning at room temperature easier.

GAS BURNER

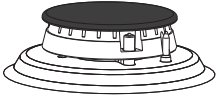

The grid, cooking surface, and burner parts may be cleaned in hot water with some washing up detergent. Do not clean them in a dishwasher.

Clean the thermocouple and the spark plug with a soft brush.

These parts have to be spotlessly clean to function correctly.

Clean the burner crown and cap. Make sure the slots on the burner crown are not clogged or otherwise blocked. After cleaning, thoroughly dry all the parts and reassemble them correctly. Any part placed askew will make burner ignition harder.

 Burner caps are finished in black enamel. Due to high temperatures, discoloration cannot be avoided. However, it does not affect burner operation.

USING THE AQUA CLEAN FUNCTION TO CLEAN THE OVEN

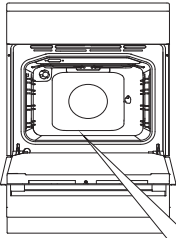

1 Ignite the gas in the oven and rotate the system selector knob to the AQUA CLEAN position .

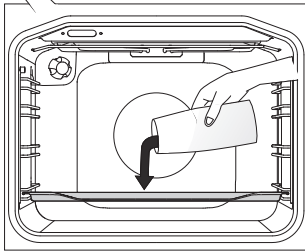

2 Pour 0.6 l water into a baking tray and place it in the lower guide.

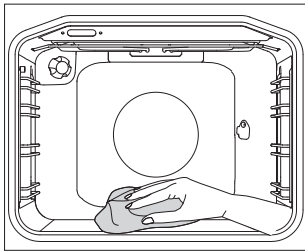

3 After 30 minutes, food residues on the oven enamel walls will have softened and they will be easy to clean with a damp cloth.



Use the Aqua Clean system when the oven has fully cooled down..

CLEANING THE INSERT BOTTOM PANEL

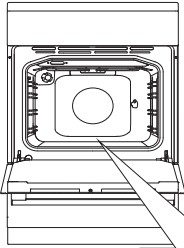

Allow the bottom insert to cool down completely.

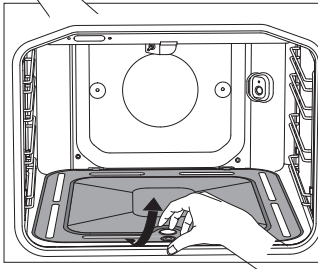

1 Slightly lift the bottom insert in the middle of the front edge and pull it out of the oven.

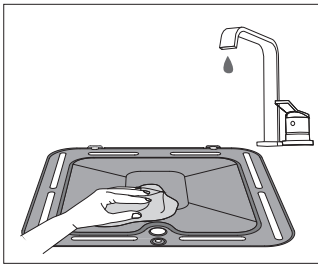

2  Clean it with non-abrasive cleaners and degreasers. However, make sure it is rinsed well under running water so that there are no residues of detergent on the surface. Then, wipe it dry.

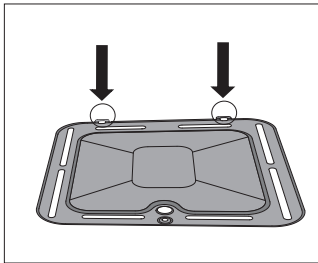

3 Insert it into the holes left and right at the back and fixed at the front to prevent it from moving when the oven is used the next time.



If the bottom insert is not correctly placed and fixed, it could affect the quality of the cooking process.

REMOVING AND CLEANING WIRE AND TELESCOPIC EXTENDIBLE GUIDES

Only use conventional cleaners to clean the guides.

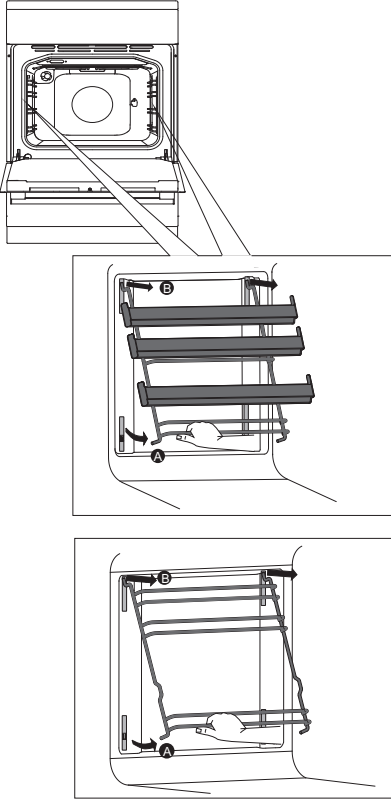

A Hold the guides at the bottom side and pull them towards the center of the oven cavity.

B Remove them from the openings at the top.

To replace the guides, observe the reverse order.

WARNING:

Do not remove the clamps inserted in the oven.



Do not clean the extendible guides in the dishwasher.

REMOVING AND INSERTING THE OVEN DOOR

(depending on the model)

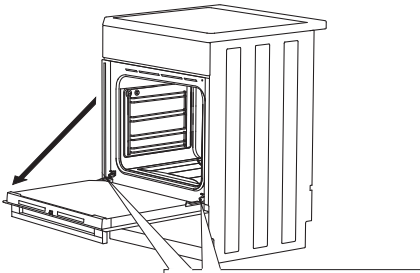

1 First, fully open the door (as far as it will go).

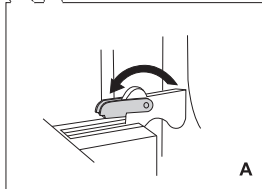

2 A Rotate the stoppers all the way back (in case of conventional closing).

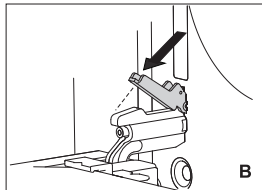

B With soft closing system, rotate the stoppers back by 90°.

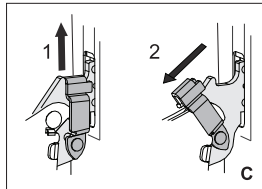

C If the appliance is fitted with the GentleClose system, slightly lift the door latches and pull them towards you.

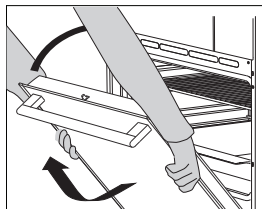

3 Slowly close the door until the latches are aligned with the slots. Slightly lift the door and pull it out from both hinge slots on the appliance.

To replace the door, follow the reverse order. If the door does not open or close properly, make sure the notches on the hinges are aligned with the hinge beds.



When replacing the door, always make sure the hinge retainers are correctly placed in the hinge beds to prevent sudden closing of the main hinge which is connected to a strong main spring. If the main spring is engaged, there is a risk of injury.

DOOR LOCK (depending on the model)

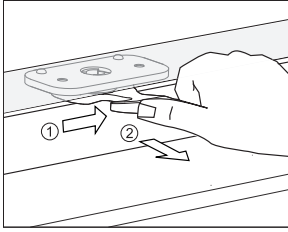

To open it, gently push it to the right with your thumb and pull the door outwards at the same time.

 **When the oven door is closed, the door lock automatically returns to the initial position.**

DEACTIVATING AND ACTIVATING THE DOOR LOCK

 **The oven should be cooled down completely.**

First, open the oven door.

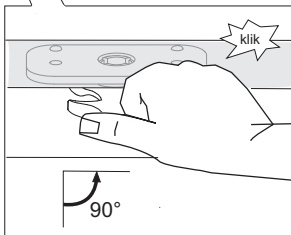
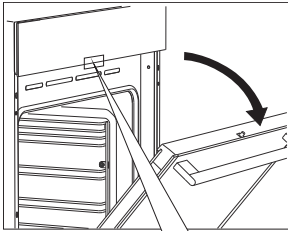

Push the door lock to the right by 90° with your thumb until you feel a click. The door lock is not deactivated.

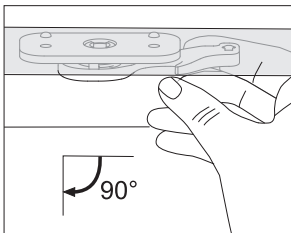

To reactivate the door lock, open the oven door and use your right-hand index finger to pull the lever towards you.

SOFT DOOR CLOSING (depending on the model)

Oven door is fitted with a system that dampens the door closing force, starting at the 75-degree angle. It allows simple, quiet, and smooth closing of the door. A gentle push (to a 15-degree angle relative to the closed door position) is enough for the door to close automatically and softly.



If the force applied to close the door is too strong, the effect of the system is reduced or the system will be bypassed for safety.

REMOVING AND INSERTING THE OVEN INNER DOOR GLASS

(depending on the model)

Oven door glass pane can be cleaned from the inside, but it has to be removed first. Remove the oven door (see chapter "Removing and replacing the oven door").

Depending on appliance model, the glass in the door is removed either as described in METHOD 1 or METHOD 2.

METHOD 1 (depending on the model)

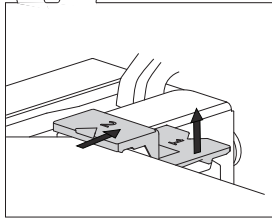
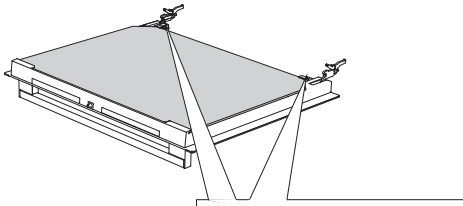

1 Slightly lift the supports on the left and right side of the door (marking 1 on the support) and pull them away from the glass pane (marking 2 on the support).

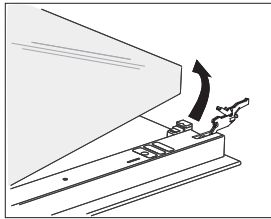

2 Hold the door glass pane by the lower edge, slightly lift it so that it is no longer attached to the support and remove it.

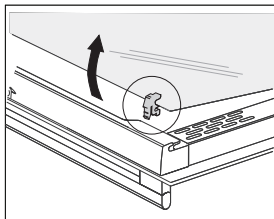

3 To remove the third glass pane (only with some models), lift and remove it. Also remove the rubber seals on the glass pane.



To replace the glass pane, follow the reverse order. The markings (semicircle) on the door and the glass pane should overlap.

METHOD 2 (depending on the model)

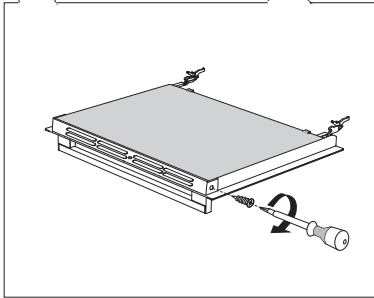
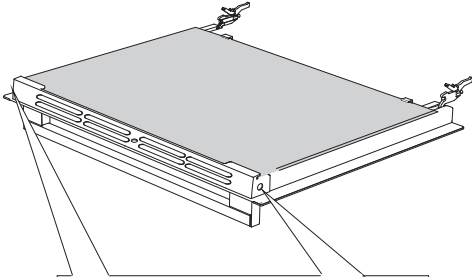

1 Undo the holder screws on both sides of the door.

.....

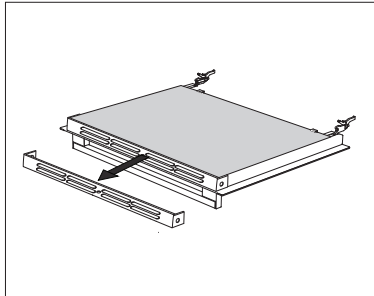

2 Remove the holder.

.....

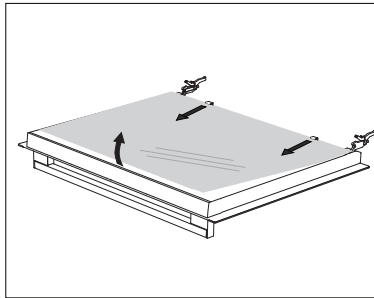

3 Slightly lift the door glass and remove it from the clips on the bottom side of the door.

To replace the door glass, observe the reverse order.

REPLACING THE BULB

The bulb is a consumable and therefore not covered by warranty. Before changing the bulb, remove the trays, the grid, and the guides.

(Halogen lamp: G9, 230 V, 25 W; regular bulb E14, 25 W, 230 V)

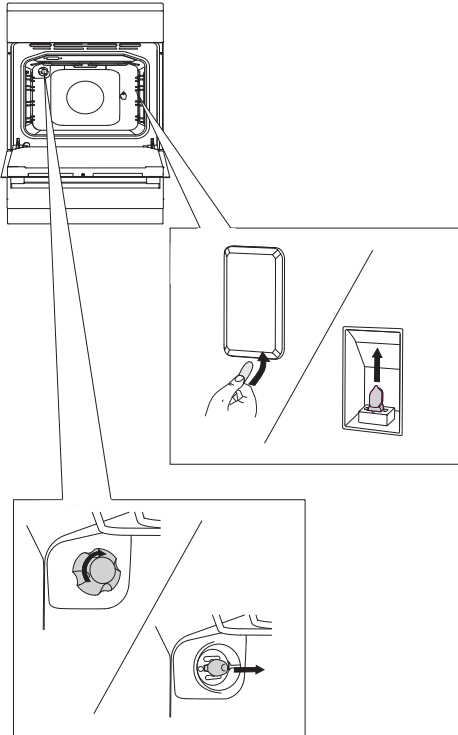

Use a flat screwdriver to release the bulb cover and remove it. Remove the bulb.

💡 Be careful not to damage the enamel.

.....

Release the bulb cover and remove.

💡 Use protection to avoid burns.

SPECIAL WARNINGS AND FAULT REPORTING

During the warranty period, any repairs may only be carried out by a service technician authorized by the manufacturer.

Before starting any repairs, disconnect the appliance from the power mains by removing or tripping the fuse or by disconnecting the plug from the wall outlet.

Any unauthorized repairs of the cooker may result in electric shock and short circuit hazard; therefore, do not conduct them. Leave such work to an expert or the service unit.

In case of minor problems with appliance operation, check this manual to see if you can fix the problem yourself.

Important

A visit by a service technician during the warranty period is not free of charge if the fault occurred because appliance was not operated correctly.

Keep this instruction manual handy. If you pass the appliance on to a new owner, pass on the instruction manual as well.

Following are some troubleshooting tips.

Problem/error	Cause
The main fuse in your home trips often.	Call a service technician.
The oven lighting does not work.	The process of changing the light bulb is described in the chapter Maintenance&Cleaning.
The pastry is underdone.	Did you choose the right temperature and heating system? Is the oven door closed?
The burners do not burn evenly.	Have an expert check the gas settings.
Burner flame suddenly changes, the knob has to be depressed longer to ignite the burner.	Make sure the burner is assembled correctly.
The flame is extinguished after ignition.	Hold the knob depressed for a longer period of time. Before releasing the knob, press it harder.
There is discolouration on the grid in the burner area.	This is a normal phenomenon resulting from high temperature. Clean the grid with a metal cleaner.

Problem/error	Cause
Electric burner ignition no longer works.	Carefully clean the opening between the spark plug and the burner. Clean the burner caps with a metal cleaner. Place the burner cover correctly.

If the problems persist despite observing the advice above, call an authorized service technician. Repairs or any warranty claims resulting from incorrect connection or use of the appliance shall not be covered by the warranty. In such cases, the costs of repair shall be charged to the user.

INSTALLATION AND CONNECTION INSTRUCTIONS

APPLIANCE PLACEMENT

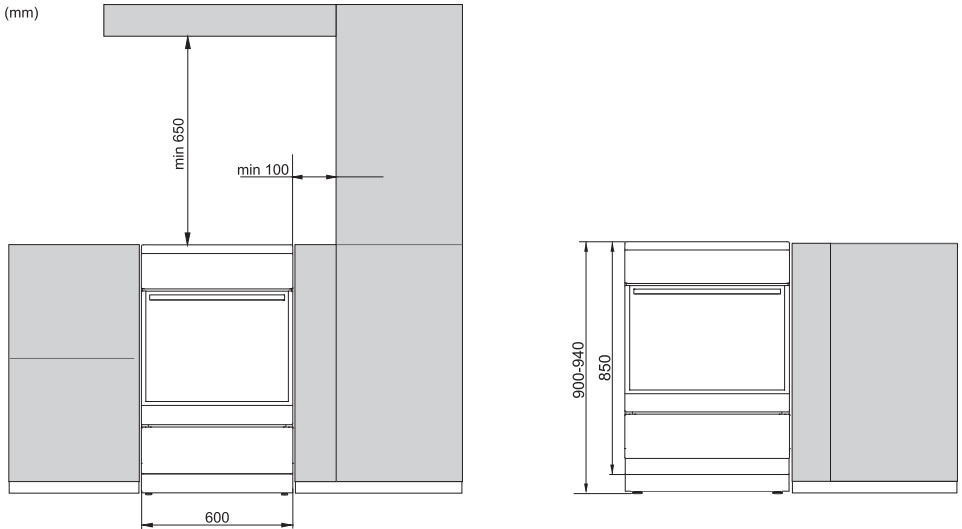

The walls or furniture adjacent to the appliance (floor, rear kitchen wall, side walls) have to be temperature-resistant to at least 90 °C.

LEVELLING THE APPLIANCE AND ADDITIONAL SUPPORT

A)

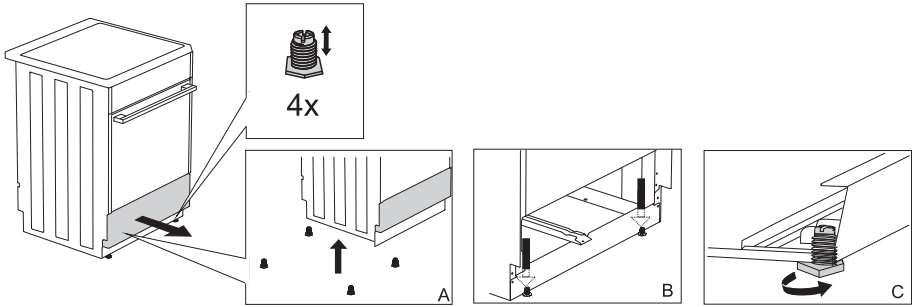

B)

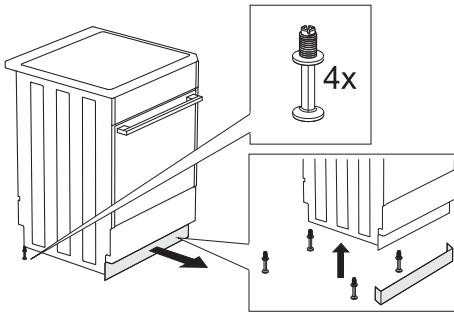

C)

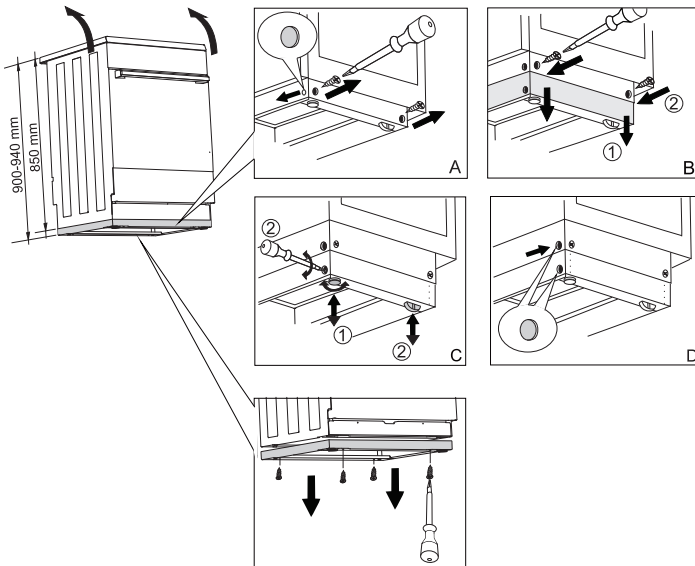

PREVENTION FROM TIPPING OVER

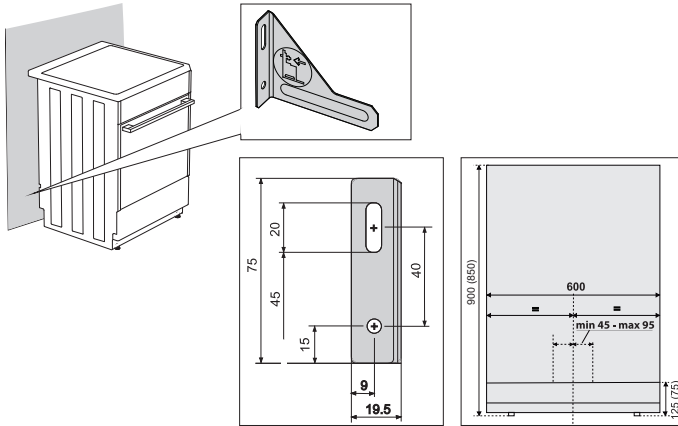

 Dimensions in the parenthesis represent built-in measures of the support bracket without the additional support. If the supplied element protecting the appliance from tipping over cannot be firmly secured to your wall with the screws and the wall plugs supplied, use other fittings to secure the bracket in such way that it cannot be pulled out from the wall.

CONNECTING TO THE POWER MAINS

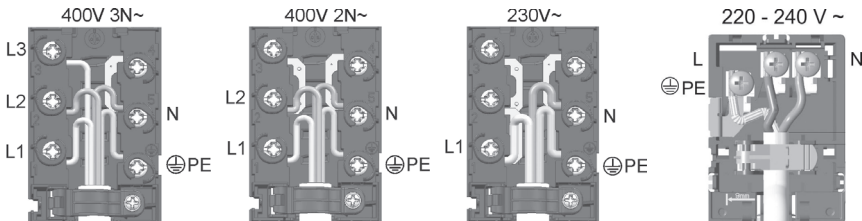
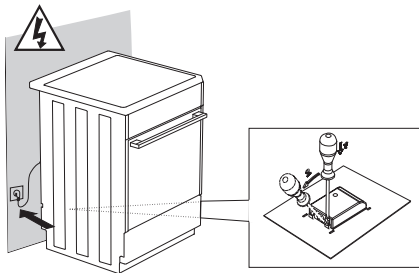

The supplied cap must be placed over the connecting clip!

GAS CONNECTIONS

FACTORY DEFAULT SETTINGS

- Gas appliances are tested and fitted with the CE sign.
- Gas appliances are supplied sealed with burners adjusted to natural gas type H or E (20 mbar), or to liquefied natural gas (50 or 30 mbar).
The information is provided on the appliance rating plate found on the interior of the oven. It is visible when the oven door is opened.
- Before connecting the appliance, make sure the local requirements for connection (gas type and pressure) are compatible with the appliance settings.
If the gas you are using is not compatible with the current settings on your appliance, call a service technician or the distributor.
- Modifying the hob to operate with a different type of gas requires replacement of the nozzles (see section NOZZLE TABLE).
- In case of repairs or if the seal is damaged, the functional parts have to be tested and re-sealed in compliance with the installation instructions. The functional parts include the following: fixed nozzle for large flame and adjustable regulation screw for small flame.

CONNECTING TO GAS SUPPLY

- Appliance has to be connected to the mains gas or the gas cylinder according to the instructions of your local gas distribution company.
- There is a gas connection plug on the right-hand side of the appliance, with external thread EN ISO 228-1 which can be converted to EN ISO 10226-1 / -2 with additional adapter and gasket (depending on the connection regulations in the specific country).
- A liquefied natural gas connection and a non-metal gasket are also supplied (depending on the model).
- When connecting the appliance to the gas supply, the part has to be held to prevent it from rotating.
- Use approved non-metal gaskets and approved sealants for sealing the connection joints. Use each gasket only once. The thickness of flat non-metal gaskets may be deformed up to 25%.
- Connect the appliance to the gas supply using a certified flexible hose. The hose should not touch the lower appliance wall, the back wall or the oven ceiling.

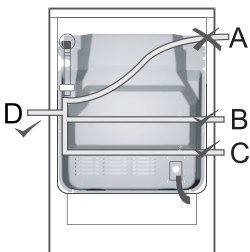

Connection with a flexible hose

If the appliance is connected with a flexible hose, the path of the hose indicated with "A" is not acceptable.

If a metal pipe is used, option A is permissible as well.

Gas connection plug

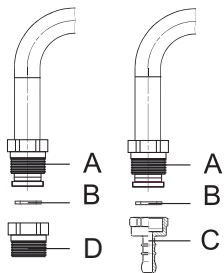

- A** Connection EN ISO 228-1
- B** Non-metal gasket, thickness 2 mm
- C** Hose plug for gas (depending on the connection regulations in the specific country)
- D** Hose plug EN ISO 10226-1/-2 (depending on the connection regulations in the specific country) (supplied, depending on the model)

After connection, check the operation of the burners. The flames have to burn with clearly visible blue and green core. If the flame is unstable, increase the minimum power as necessary. Explain to the user how the burners operate and review the instruction manual together.



After connecting the appliance, check the seal on all joints.

MODIFYING THE BURNERS FOR USE WITH A DIFFERENT TYPE OF GAS

- Modifying the burners for use with a different type of gas does not require removing the hob from the countertop.
- Before making the modifications, unplug the appliance from the mains power and shut off the gas supply valve.
- Replace the existing nozzle for the nominal heat load with suitable nozzles for the new type of gas (see table).
- When modifying the appliance for use with liquefied natural gas, tighten the minimum heat load regulation screw all the way to reach the minimum heat load.
- When modifying the appliance for use with natural gas, undo the minimum heat load regulation screw to reach the minimum heat load, but by no more than 1.5 turns.

After modifying the appliance for use with a different type of gas, replace the old sticker with gas type information (on the rating plate) with the relevant new sticker and test the functionality and sealing of the appliance.

Make sure the electric conductors, thermostat capillary and thermo elements do not protrude into the gas flow area.

Adjustment elements

- Adjustment elements for minimum heat load of the burners are accessible through the openings on the control panel.
- Remove the support grid, burner caps and burner crowns.
- Remove the control knobs.

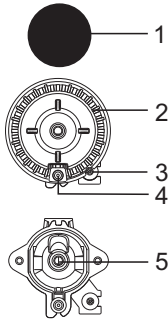

Cooking burner

- 1. Burner crown cap
- 2. Burner crown with burner cap support
- 3. Thermo element (only with some models)
- 4. Spark plug
- 5. Nozzle

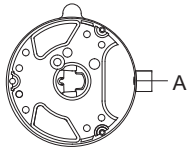

Triple (three-ring) burner

- A Nozzle

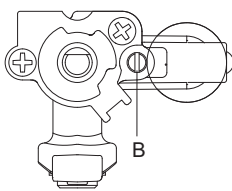

Gas valve with a safety device

- B Minimum heat load regulation screw

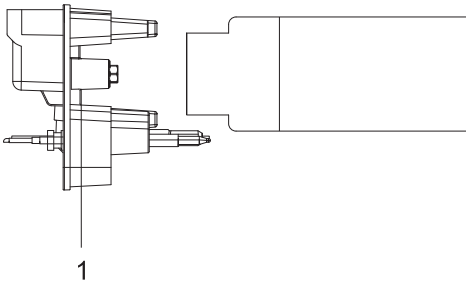

Oven burner controls

To access the parts required to adjust the oven burner to another type of gas, the control panel, bottom insert and oven burner have to be disassembled (undo the screws in the front part of the heater, remove the ignition plug and the flame control device (thermo element) and pull out the heater). To access the oven nozzle, disassemble the shutter.

- 1 Nozzle

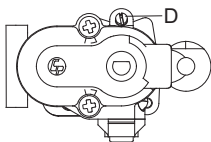

Temperature-controlled gas tap

- D Minimum heat load regulation screw

NOZZLE TABLE

Gas type, pressure		Auxiliary burner		Normal burner	
		max	min	max	min
Natural gas H $W_o=45,7\div 54,7 \text{ MJ/ m}^3$, Natural gas E, Natural gas E+ $W_o=40,9\div 54,7 \text{ MJ/ m}^3$ G20, p=20mbar	Nominal heat load (kW)	1	0,48	1,9	0,48
	Consumption (l/h)	95	46	181	46
	Nozzle type (1/100 mm)	72 X	26	103 Z	26
	Nozzle ID	690771		568169	
Liquefied gas 3+, B/P $W_o=72,9\div 87,3 \text{ MJ/ m}^3$ G30 p=30 mbar	Nominal heat load (kW)	1	0,48	1,9	0,48
	Consumption (g/h)	73	35	138	35
	Nozzle type (1/100 mm)	50	26	68	26
	Nozzle ID	690780		568175	

Gas type, pressure		Large burner		Multi-ring burner	
		max	min	max	min
Natural gas H $W_o=45,7\div 54,7 \text{ MJ/ m}^3$, Natural gas E, Natural gas E+ $W_o=40,9\div 54,7 \text{ MJ/ m}^3$ G20, p=20mbar	Nominal heat load (kW)	3	0,76	3,6	1,56
	Consumption (l/h)	286	72	343	149
	Nozzle type (1/100 mm)	130 H3	33	145 H3	57
	Nozzle ID	574285		568170	
Liquefied gas 3+, B/P $W_o=72,9\div 87,3 \text{ MJ/ m}^3$ G30 p=30 mbar	Nominal heat load (kW)	3	0,76	3,5	1,56
	Consumption (g/h)	218	55	255	114
	Nozzle type (1/100 mm)	86	33	94	57
	Nozzle ID	574286		568176	

Gas type, pressure		Oven burner		Infra burner
		max	min	
Natural gas H $W_o=45,7\div 54,7$ MJ/ m ³ , Natural gas E, Natural gas E+ $W_o=40,9\div 54,7$ MJ/m ³ G20, p=20mbar	Nominal heat load (kW)	3	0,8	2,2
	Consumption (l/h)	286	76	210
	Nozzle type (1/100 mm)	117	33	108
	Nozzle ID	568171		568173
Liquefied gas 3+, B/P $W_o=72,9\div 87,3$ MJ/m ³ G30 p=30 mbar	Nominal heat load (kW)	3	0,8	2,2
	Consumption (g/h)	218	58	160
	Nozzle type (1/100 mm)	82	33	75
	Nozzle ID	568177		568178

- Regulation screws for liquefied gas are installed and set in factory to the gas type for which the factory default settings apply.
- When modifying the appliance for use with a different type of gas, the regulation screw has to be tightened or undone to set the required gas flow (do not undo the regulation screw by more than 1.5 turns).

Burner power is indicated by observing the upper Hs caloric value.



Connection to gas supply and adjustment to a different type of gas may only be carried out by an expert authorized by the gas distributor or an authorized service technician!

DISPOSAL



Packaging is made of environmentally friendly materials that can be recycled, disposed of, or destroyed without any hazard to the environment. To this end, packaging materials are labelled appropriately.

The symbol on the product or its packaging indicates that the product should not be treated as normal household waste. The product should be taken to an authorized collection center for electric waste and electronic equipment processing.

Correct disposal of the product will help prevent any negative effects on the environment and health of people which could occur in case of incorrect product removal. For detailed information on removal and processing of the product, please contact the relevant municipal body in charge of waste management, your waste disposal service, or the store where you bought the product.

We reserve the right to any changes and errors in the instructions for use.

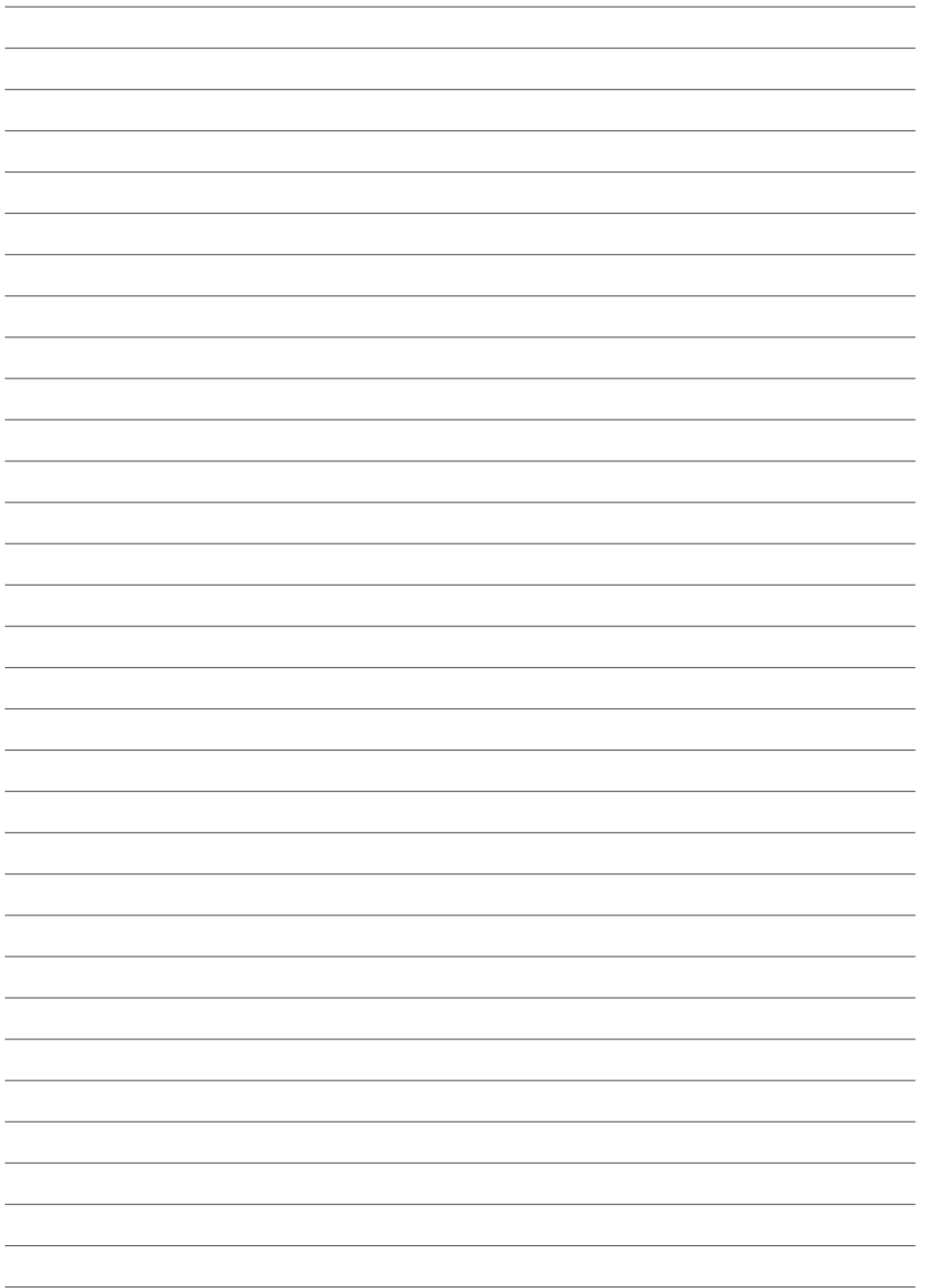

FG6A EGT



en (09-20)