

X1-3D

Monitorarm mit Gasfeder

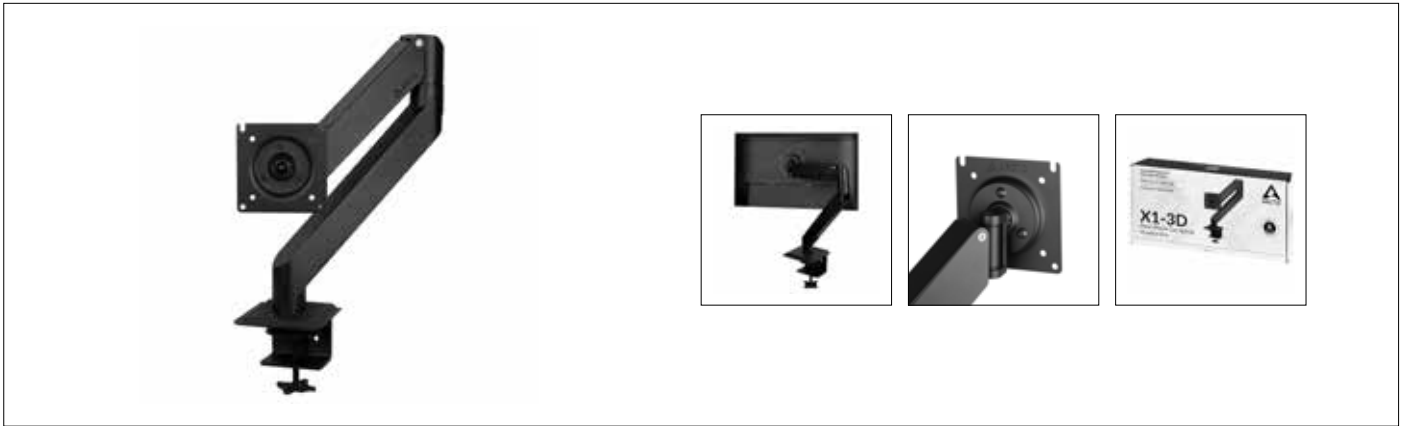

Allgemeine Spezifikationen

Monitorgröße	≤ 40"/≤ 43" Ultrawide Monitor
VESA Standard	VESA 75 (75x75) ; VESA 100 (100x100)
Maximales Monitorgewicht	10 kg/22 lbs
Rotation	360°
Drehgelenk	180°
Neigung	+/-15°
Lift	207-525 mm
Stärke des Tisches	20-55 mm
Material	Stahl, Aluminiumlegierung ADC 12, Zinklegierung
Gewicht	3,5 kg
Farbe	Mattschwarz

Versandinformationen

Box Abmessungen	445 (L) x 228 (B) x 124 (H) mm
Brutto Gewicht	3,925 kg
SKU	AEMNT00062A
EAN	4895213703598
UPC	840033401401

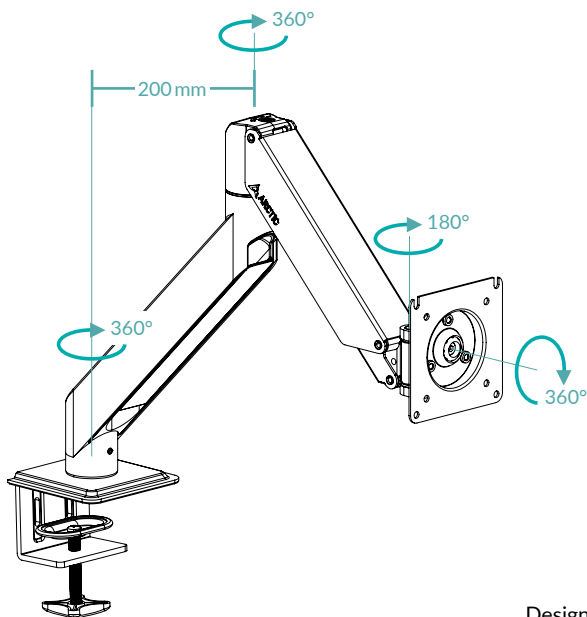
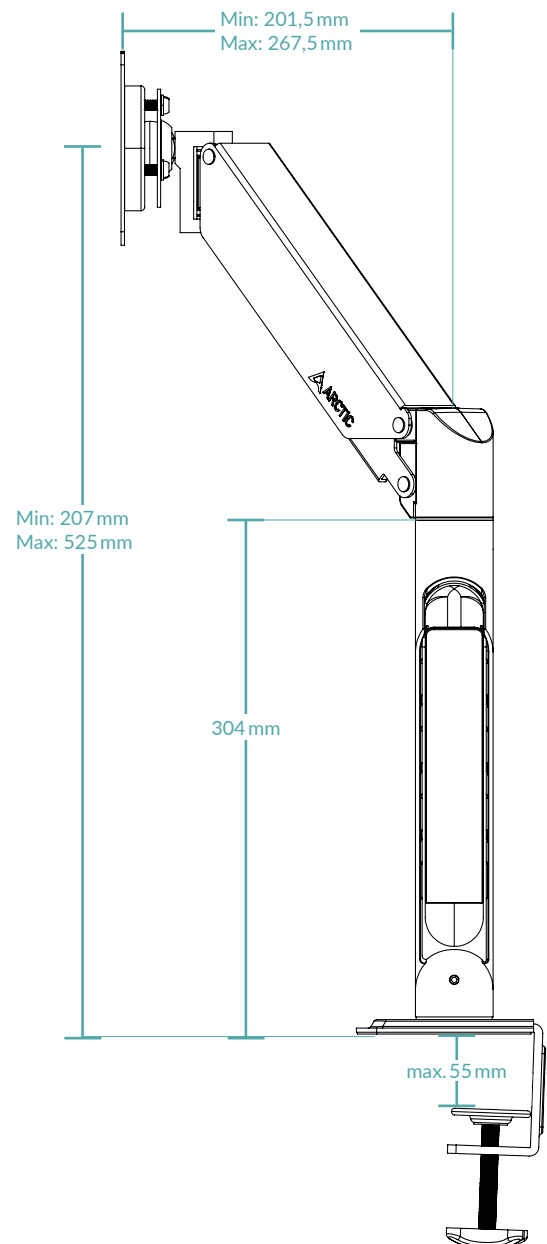

Designed by ARCTIC

Alle Materialien sind mit den RoHS-Anforderungen kompatibel



Produktinformation



Manual