

|C|D|A|

# EVX90SS

Ceiling extractor

Use and maintenance

# Contents

- 3 Important information
- 5 Using your extractor
- 6 Care and maintenance
- 7 Installation instructions for standard fitting
- 15 Installation instructions for mounting the motor externally
- 15 Ducting
- 16 Recirculation
- 17 Mains electrical connection
- 18 Guarantee
- 19 Troubleshooting
- 20 Energy efficiency information

## Important information

The CDA Group Ltd cannot be held responsible for injuries or losses caused by incorrect use or installation of this product. Please note that CDA reserve the right to invalidate the guarantee supplied with this product following incorrect installation or misuse of the appliance or use in a commercial environment. This appliance is not designed to be used by people (including children) with reduced physical, sensorial or mental capacity, or who lack experience or knowledge about it, unless they have had supervision or instructions on how to use the appliance by someone who is responsible for their safety. Under no circumstances should any external covers be removed for servicing or maintenance except by suitably qualified personnel.

### **Appliance Information:**

Please enter the details on the appliance rating plate below for reference, to assist CDA Customer Care in the event of a fault with your appliance and to register your appliance for guarantee purposes.

Appliance model	
-----------------	--

Serial number	
---------------	--

### **EU Declarations of Conformity:**

This appliance has been manufactured to the highest standards and complies with all applicable legislation, including Gas safety, Electrical safety (LVD) and Electromagnetic interference compatibility (EMC).

## **IMPORTANT INFORMATION FOR CORRECT DISPOSAL OF THE PRODUCT IN ACCORDANCE WITH EC DIRECTIVE 2012/19/EU.**

At the end of its working life, the product must be taken to a special local authority waste collection centre or to a dealer providing appliance recycling services. Disposing of a household appliance separately avoids possible negative consequences for the environment and health. It also enables the constituent materials to be recovered, saving both energy and resources. As a reminder of the need to dispose of household appliances separately, the product is marked with a crossed-out wheeled dustbin. 

### **Please note:**

- Under no circumstances should the extractor be connected to any gas ventilation system, flue system or hot air ducting system
- Do not vent the extractor into an attic or loft space
- Only house the extractor in rooms with adequate ventilation. Remember that the extractor is powerful and extracted air needs to be replaced
- Do not use silicone sealant to secure the hood to the ceiling
- You must be able to isolate the extractor from the mains electrical supply after installation
- Steam cleaners must not be used when cleaning this appliance
- The performance of your extractor will vary depending on a number of factors. These include: type of extraction, length of ducting, room volume, ventilation available and cleanliness of the filters

# Using your extractor

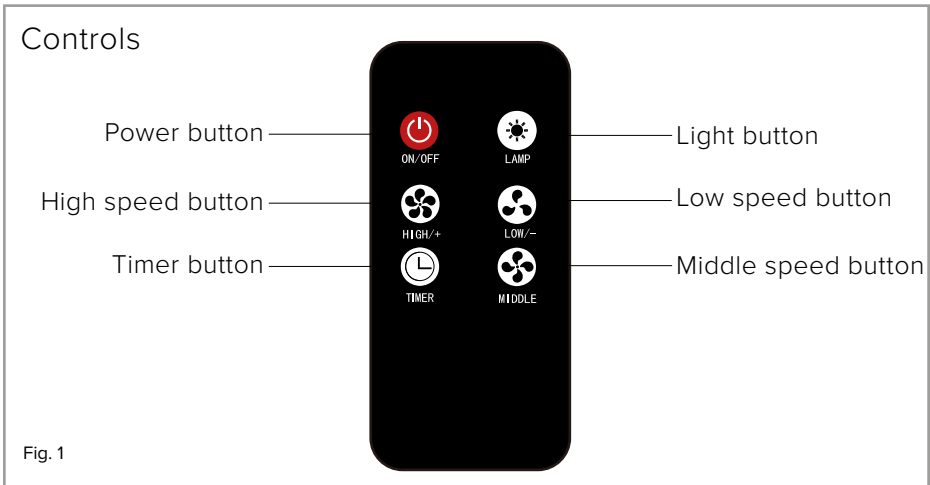

## Power button

Pressing once will start the extractor at the lowest speed setting, pressing again will turn the extractor off

## Light button

Turn the lights of the extractor on or off

## High speed button

Press to activate the highest speed setting, the display will show the number 3. Holding this button down for 3 seconds activates the booster function for 5 minutes and the display will show the letter B

## Middle speed button

Press to activate the middle speed setting, the display will show the number 2

## Low speed button

Press to activate the lowest speed setting, the display will show the number 1

## Timer button

Pressing this button will activate the timer function and cause the display number to flash. The extractor will automatically turn off after 15 minutes. Changing the speed setting will not cancel this function. To cancel this function simply press the timer button again

# Care and Maintenance

## Cleaning

You should use a non-abrasive cleaner. Any abrasive cleaner (including Cif) will scratch the surface and leave marks on the extractor. You can clean your extractor effectively by simply using a dilute solution of water and mild detergent and drying to a shine with a clean cloth.

## Removing and cleaning the grease filters

To remove the grease filter push in on the button on the handle and pull it down, when the catch is released at the front it can be removed completely. The grease filters should be kept clean to minimise the risk of fire, you should remove and clean the grease filters with hot soapy water. You can also wash the grease filters in a dishwasher, ensuring that you place them in an upright position to prevent damage from other items in the dishwasher. After rinsing and drying, replace the grease filter by reversing the removal process. **Please note:** Cleaning the grease filters in the dishwasher may lead to discolouration. This is normal and does not constitute a fault with the appliance.

## Changing the charcoal filters (if fitted)

To ensure best performance of your extractor, you should replace the charcoal filter every four to six months, depending on use. To attach a new charcoal filter, first remove the grease filters as described above. Offer up the charcoal filter so that the magnetic pins are facing upwards, one to the rear and one to either side. The filter will be held in place by magnetic force. Finally, replace the grease filters

# Installation instructions for standard fitting

## Please note:

All installation measurements given are in millimeters

Make a cutout in the ceiling with the measurements below

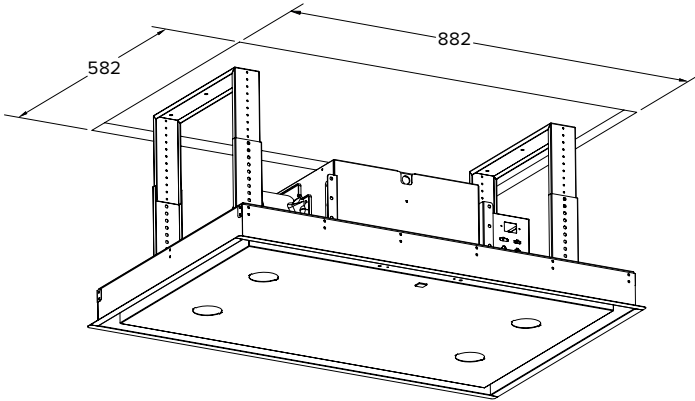

Fig. 2

Dimensions for installation reference

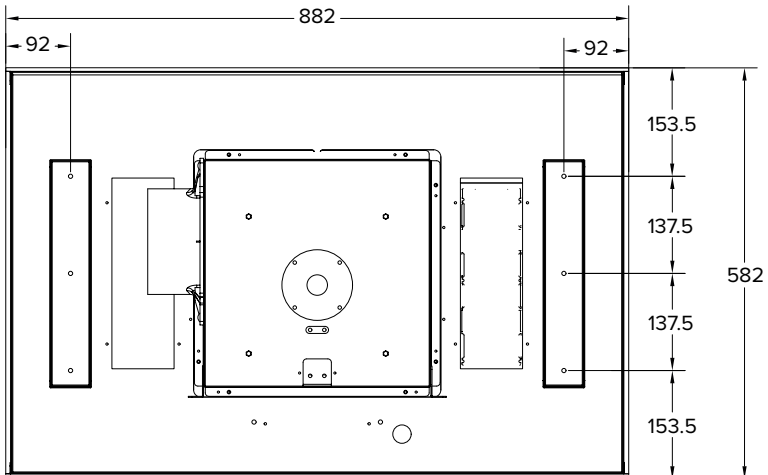

Fig. 3

Fix the upper bracket to the support structure

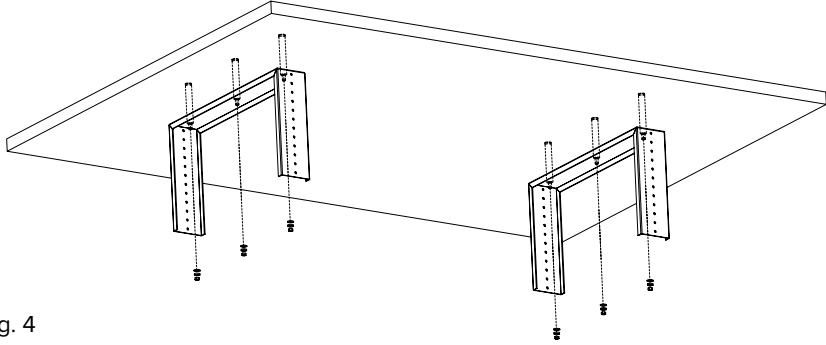

Fig. 4

Fasten the lower bracket to the upper bracket with the 8 screws supplied. We recommend having an 85 - 100mm gap between the opening in the ceiling and the lowest point of the lower bracket

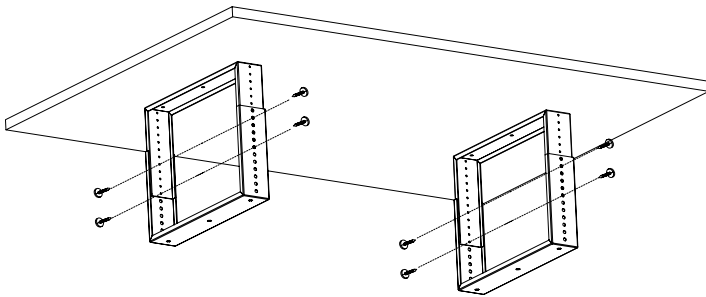

Fig. 5

Fix the duct outlet to the extractor with the 4 screws supplied

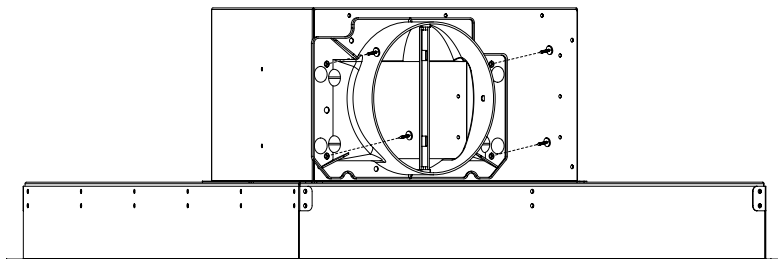

Fig. 6



Locate the extractor in the ceiling opening, make sure to connect your ducting and mains electrical connection before proceeding to the next step

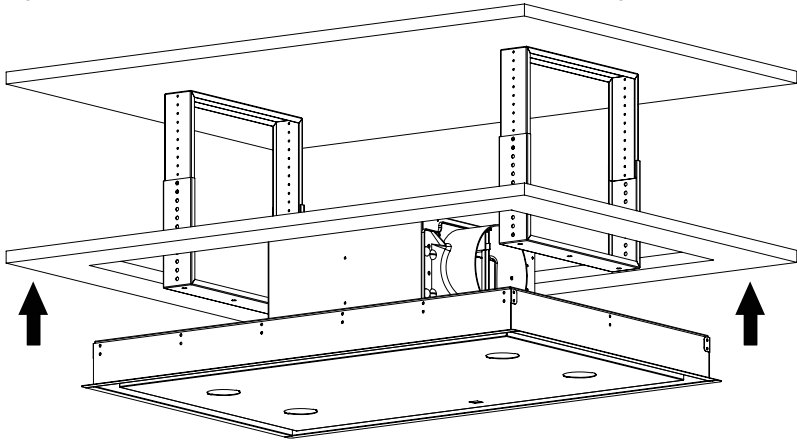

Fig. 7

Fix the extractor to the bracket with the 6 screws and washers provided. Tighten evenly on both sides until secure, be careful to not overtighten

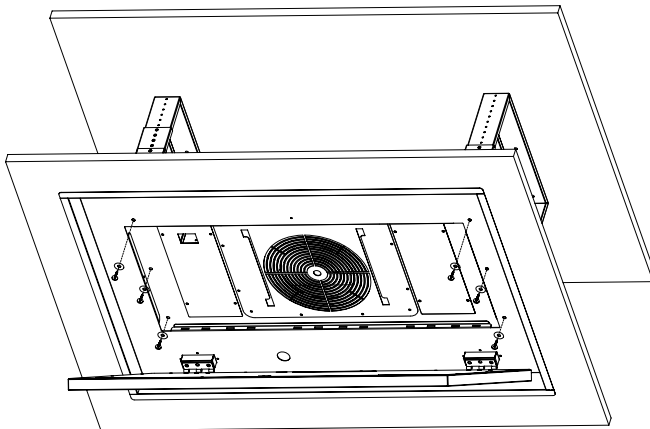

Fig. 8

# Installation instructions for mounting the motor externally

Remove the 8 screws fixing the motor housing on the extractor and detach it from the casing

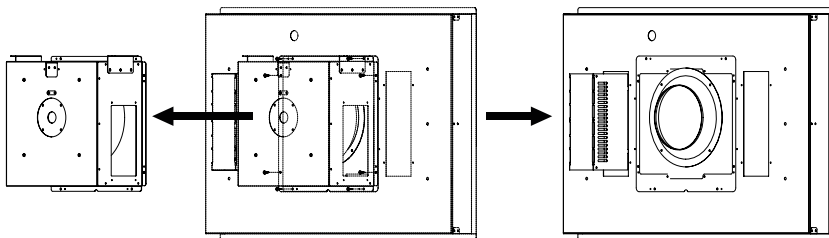

Fig. 9

Remove the four screws that fix the airguide to the housing and remove it

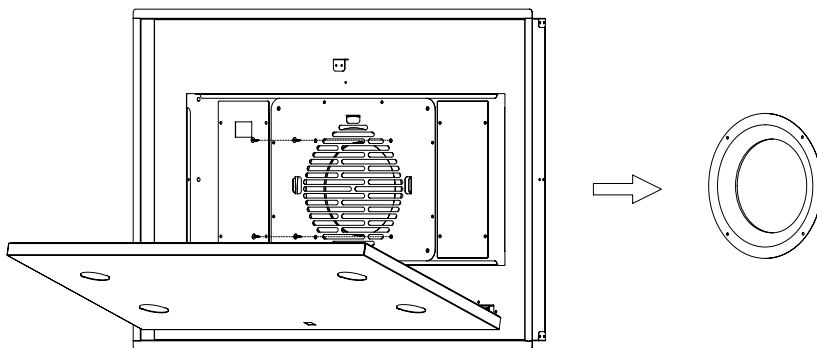

Fig. 10

Connect the two duct adaptors on both of the panels

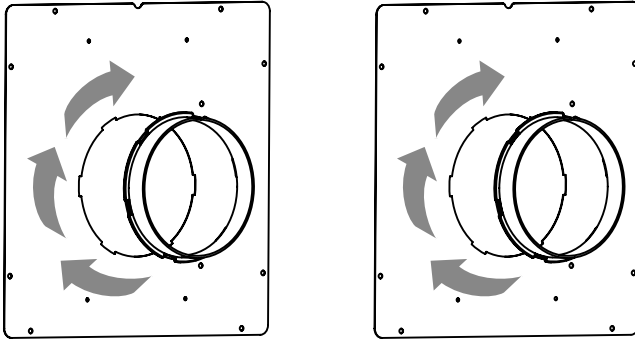

Fig. 11

Fix the airguide to the panel using the four screws removed in Fig. 10; note that the air guide is fixed to the opposite side of the duct adaptor

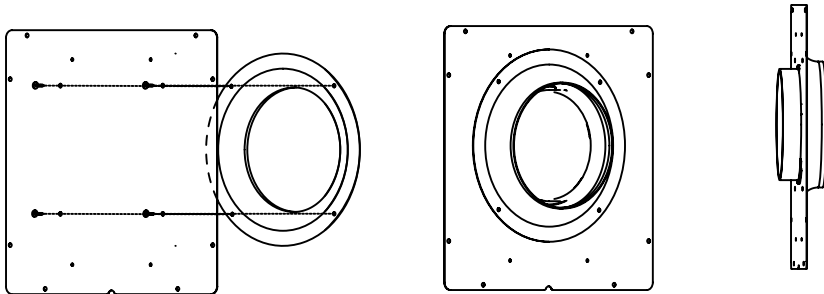

Fig. 12

Fix the panel with the airguide to the motor housing with the 8 screws supplied; note that the airguide is facing the motor

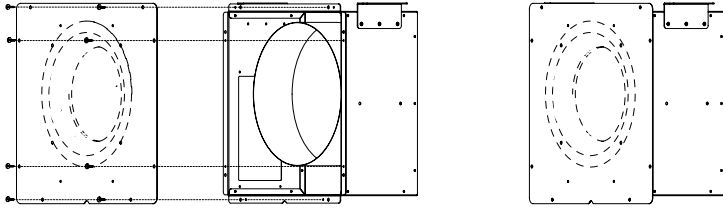

Fig. 13

Secure the second panel to the rear of the extractor with the 8 screws supplied

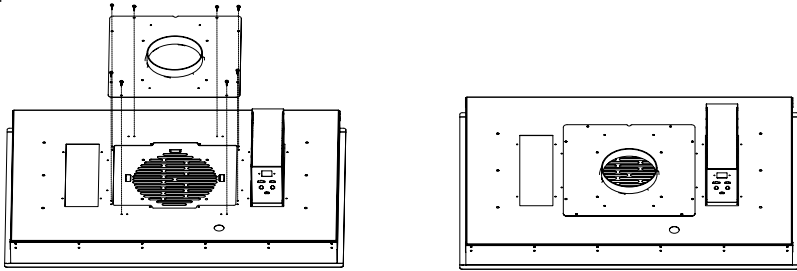

Fig. 14

Locate the extractor in the ceiling opening, making sure to connect your ducting and mains electrical connection before proceeding to the next step

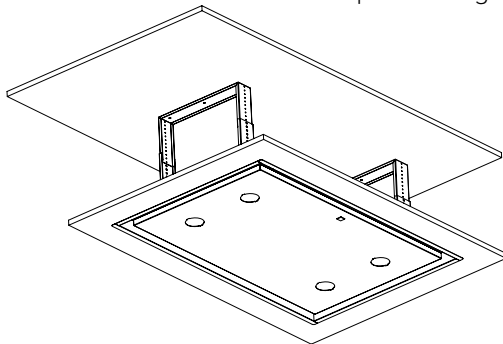

Fig. 15

Secure the motor housing to the support structure using appropriate fixings

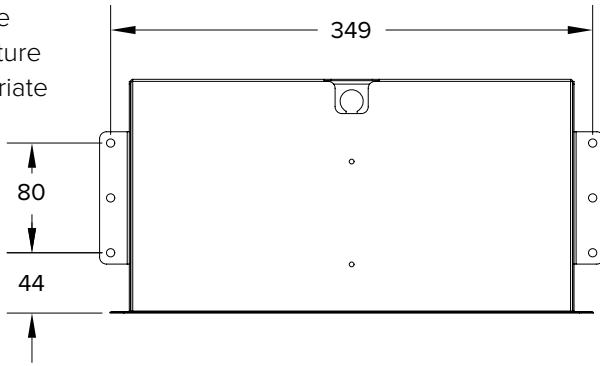

Fig. 16

Suggested mounting example

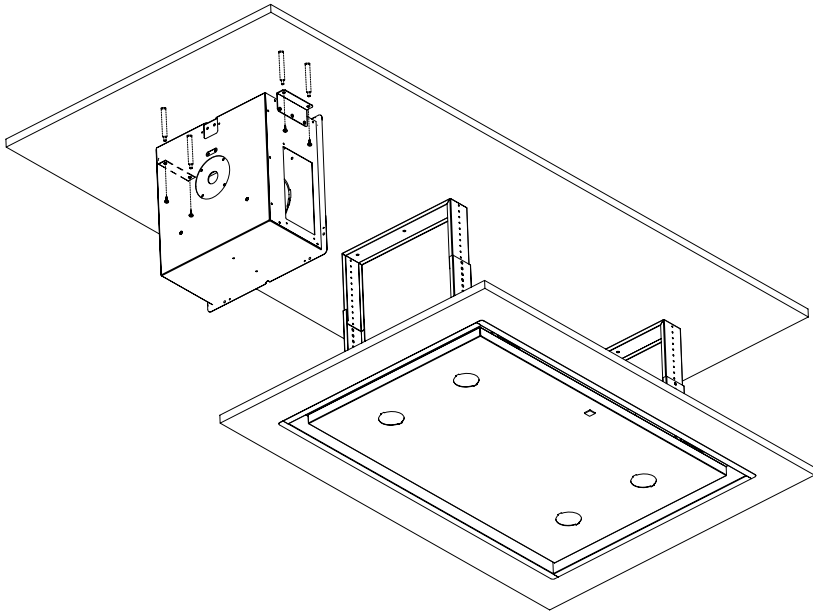

Fig. 17

Fix the duct adaptor to the motor housing using the 4 screws provided

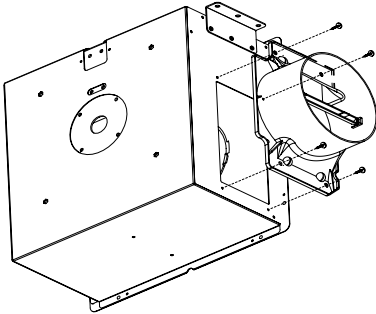

Fig. 18

Connect the motor and extractor body using a 150mm diameter ducting hose

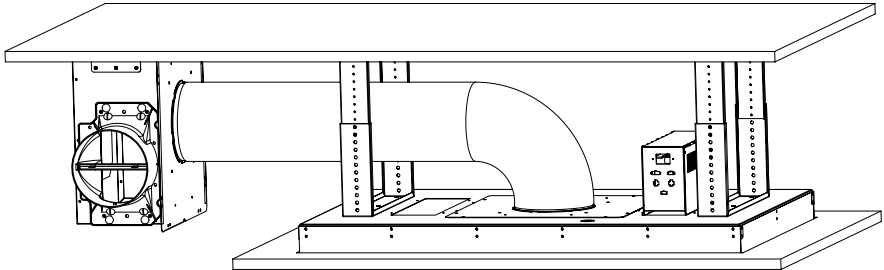

Fig. 19

# Ducting

The extractor can be used as a recirculation device or as an extraction device, depending on your installation.

The hood is more effective when used in extraction mode (ducted to the outside). When the extractor is ducted to the outside, charcoal filters are not required. The ducting used must be 150mm (6 inches), we recommend rigid circular pipe and must be manufactured from fire retardant material, produced to BS476 or DIN102-B1.

Wherever possible utilise rigid circular pipe which has a smooth interior, rather than the expanding concertina type ducting. The maximum length of ducting without performance being affected is as follows:

- 4 metres with 1 x 90° bend
- 3 metres with 2 x 90° bends
- 2 metres with 3 x 90° bends

Longer ducting can be used but the performance of the extractor will be reduced.

## **Please note:**

Ducting components and ducting kits are optional accessories and have to be ordered, they are not automatically supplied with the extractor. Use of ducting less than 150mm in diameter will affect the performance and increase the noise produced by the extractor

## Recirculation

An internal air vent is required, as shown below. This ensures that the air is placed back in the kitchen after it has been filtered. The internal air vent must be a minimum of 2 metres away from the extractor

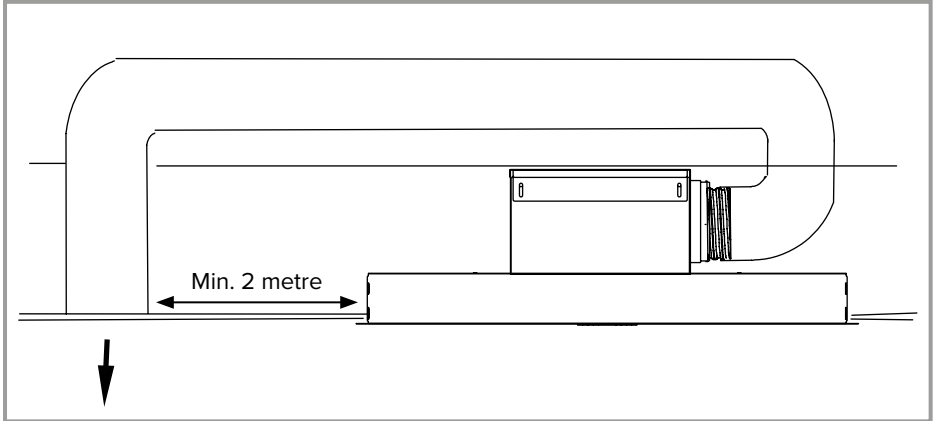

## Extraction

The extractor is provided with a non-return butterfly valve which should be fitted over the vent outlet before the ducting is fitted. This prevents cold air being blown into the room from outside.

## Securing the duct to the outlet

Note that the duct pipe should be secured and sealed to the vent outlet pipe/valve using appropriate ducting tape or a securing clamp.



# Mains electrical connection

## **Warning! This appliance must be earthed.**

This appliance must be connected by a competent person, using fixed wiring via a double pole switched fused spur outlet, protected by a 3A fuse.

We recommend that the appliance is connected by a qualified electrician, who is a member of the N.I.C.E.I.C. and who will comply with the I.E.T. and local regulations. The wires in the mains lead are coloured in accordance with the following code:

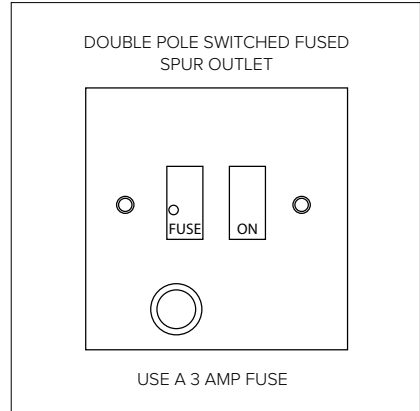

**GREEN AND YELLOW = EARTH**

**BLUE = NEUTRAL**

**BROWN = LIVE**

As the colours of the wires in the mains lead for the appliance may not correspond with the coloured markings identifying the terminals in your spur box, proceed as follows:

1. The wire which is coloured green and yellow must be connected to the terminal marked E (Earth) or coloured green
2. The wire which is coloured blue must be connected to the terminal marked N (Neutral) or coloured black
3. The wire which is coloured brown must be connected to the terminal marked L (Live) or coloured red

# Guarantee

Your new product is guaranteed against defect in materials and/or workmanship. Any parts found to be defective will be repaired or replaced at our discretion. All repairs must be carried out by an authorised repair agent. Your appliance comes with a 5 year parts and 2 year labour guarantee if registered within 30 days of purchase.

## This guarantee is valid providing that:

- The appliance has been installed by a suitably qualified person
- Installation has been carried out in accordance with instructions and current legislations
- Proof of purchase can be produced
- The appliance has been used for domestic purposes only
- The appliance has not been tampered with or repair attempted or modified by any unauthorised person

## This guarantee does not cover:

- Damage by misuse, neglect or transit
- Use of parts not used or recommended by CDA
- Routine maintenance, general wear, tear and installation faults
- Rubber seals, removable glass and/ or plastic parts, fuses or light bulbs which all need replacing periodically
- Second hand or reconditioned appliances
- Appliances used for commercial or professional purposes

# Troubleshooting

In the event of your appliance requiring technical assistance and/or spare parts, please contact CDA Customer Care.

In this case it is necessary to state all the appliance data on the rating plate, such as model, serial number etc. This information can be found behind the grease filters

## CDA Customer Care

**Phone:** 01949 862 012

**Email:** [customer.care@cda.eu](mailto:customer.care@cda.eu)

Problem	Reason	Solution
The appliance does not work	No power/ power outage	Check the fuse, replace if blown
	Wires have disconnected	
		Ensure the power supply is securely connected
Output of appliance is low	Setting is too low for amount of fumes present	Try a higher speed setting
	Inadequate ventilation in the kitchen	Ensure the kitchen has sufficient air intake
	Charcoal filter (if fitted) is blocked	Replace the charcoal filter
	Ducting is obstructed	Remove any obstructions from the ducting
	Exit flaps on the motor housing are restricted	Ensure any obstructions are removed so the flaps can move freely
Extractor stops mid operation	There is a power outage	Check the power supply
	The circuit breaker or fuse has tripped	Check the circuit breaker or fuse

## Energy Efficiency Information

Attribute	Symbol	Value	Units
Model Identification		EVX90SS	
Annual Energy Consumption	$AEC_{Hood}$	68.8	kWh
Time increase factor	f	1.0	
Fluid Dynamic Efficiency	$FDE_{Hood}$	27.1	
Energy Efficiency Index	$EEl_{Hood}$	62.6	
Measured airflow at Best Efficiency Point	$Q_{BEP}$	378.8	m <sup>3</sup> /h
Measured Pressure at Best Efficiency Point	$P_{BEP}$	423	Pa
Maximum airflow	$Q_{Max}$	675	m <sup>3</sup> /h
Measured electric power at Best Efficiency Point	$W_{BEP}$	164.5	W
Nominal lighting power	WL	7.3	W
Average illumination of the lighting system on the cooking surface	$E_{Middle}$	677	Lux
Measured power consumption in standby	$P_S$	/	W
Measured power consumption in off mode	$P_O$	0.46	W
Sound power level	$L_{WA}$	69	dBA
Grease filter efficiency	$GFE_{Hood}$	46.6(F)	%
Lamp efficiency	$LE_{Hood}$	92.7(A)	%

# Notes

# Notes

# Notes

**The CDA Group**

Harby Road

Langar

Nottinghamshire

NG13 9HY

**Sales Department**

**Phone:** 01949 862010

**Email:** [sales@cda.eu](mailto:sales@cda.eu)

**CDA Customer Care**

**Phone:** 01949 862012

**Email:** [customer.care@cda.eu](mailto:customer.care@cda.eu)

