



Vertiv™ Geist™ Rack Transfer Switch

Ultimate Reliability in
Mission-Critical Power



Vertiv™ Geist™ Rack Transfer Switch

Safeguard Your Critical IT Infrastructure in the Event of a Power Failure.

The Vertiv™ Geist™ Rack Transfer Switch delivers redundant power to single corded devices. Two independent power inputs enables users to connect to a primary and secondary power source. The Geist™ Rack Transfer Switch automatically detects the loss of power and switches the power load to the alternative power source in less than 4-8 milliseconds without the need for human intervention. This ensures equipment remains powered until the primary power source returns providing ultimate mission-critical power reliability.

The Rack Transfer Switch is an open transition switch utilizing a break-before-make process for transferring between the primary and secondary power source. This method of switching does not require phase synchronization between the two power feeds making it suitable for use in both data center and edge locations. It also includes enhanced redundant switches and fail-safe fused thermistors to mitigate current surge during transfers ensuring critical equipment is protected during fail-over.



Front view



Rear view

The Vertiv Geist Rack Transfer Switch provides the widest range of configuration options to support redundancy strategies in most data center and edge applications.

Upgradeable Technology

The Rack Transfer Switch utilizes the evolutionary upgradeable technology used in the Vertiv™ rack PDUs. It provides users with the flexibility to install the intelligence they require today, with the option to upgrade technology as needs evolve. From basic power to power monitoring, the Geist™ Upgradeable product line adapts to your business well into the future.

Enhanced Intelligence

Intelligent models provide a comprehensive view of critical IT equipment power usage at the rack or via remote access. Set user-defined thresholds to receive notifications when power and environmental conditions fall outside the desired range. Outlet level monitored units provide a granular view of equipment power usage, and Switched models enable users to turn-on, turn-off, or reboot individual outlets.

Available in a variety of single phase electrical and receptacle configurations with different intelligence options.

At A Glance

Intelligence Type

- Basic Upgradable
- Unit Level Monitored
- Outlet Level Monitored
- Switched Unit Level Monitored
- Switched Outlet Level Monitored

Rack Mount Configuration

- 1U and 2U Horizontal

Global Compliance

- UL Listed and CE Marked

Voltage Range

- 100-240V

Amperage Range

- 10A, 15A, 16A, 20A, 30A, and 32A

Receptacle Type

- Combination C13/C19, U-Lock C13, NEMA 5-15R and NEMA 5-20R
- L6-30C and IEC 2P+E IP44

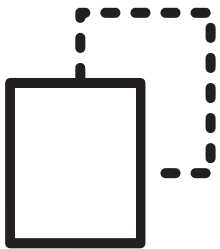

Easy to Use Front Panel Interface

The front panel interface provides visual identification of the active power source and allows users to do a manual transfer to the secondary power source remotely or with the touch of a button to perform equipment maintenance.



<4-8ms Transfer Speed

When power is lost on the primary source, the Geist Rack Transfer Switch transfers to the backup or secondary source in under 4-8 milliseconds to ensure critical IT equipment continues to receive power during a power outage.

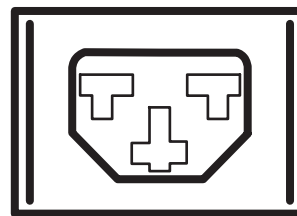

Combination Outlet C13/C19

Select models come equipped with the Combination Outlet C13/C19 accommodating either a C14 or C20 power cable in the same outlet without the need for an adapter. The 2-in-1 outlet simplifies the buying process and offers greater flexibility to accommodate ever-changing rack power requirements.

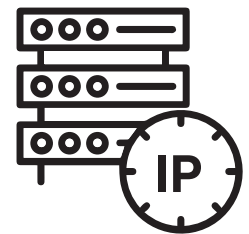

Vertiv Intelligence Director

Streamline deployment with IP aggregation of up to 50 supported Vertiv devices on a single IP address with self-configuration of downstream devices.

Vertiv™ Geist™ Rack Transfer Switch

Typical Configuration Diagrams

The Rack Transfer Switch offers ultimate deployment flexibility. Here are three common rack configurations to incorporate the Rack Transfer Switch into critical infrastructure.

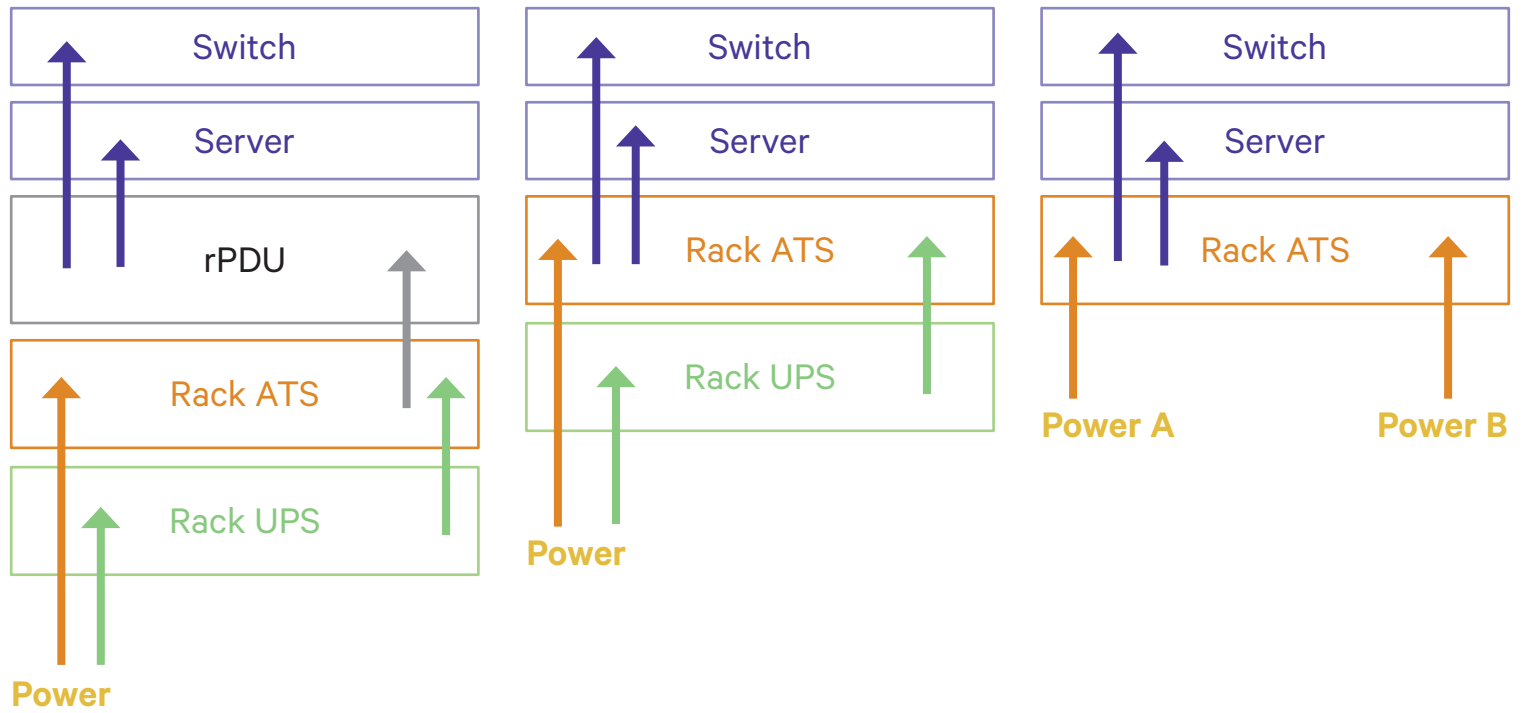

Stocked Rack Transfer Switch Models

Stocking Location	Model	Category	Sub Category	Form Factor	Volts	Amps	Max kW	Plug Type	Receptacle Qty / Type	Max Operating Temp*	VI Director
AMER	VA4U1100	Rack Transfer Switch	Monitored Unit Level	1U	100-240V	10A or 15A	1.4kW (120V), 2.4kW (208V), 2.3kW (230V)	(2) C14 Inlet	(10) U-Lock C13	60°C	YES
AMER	VA4N1100	Rack Transfer Switch	Monitored Unit Level	1U	100-120V	15A	1.4kW (120V)	(2) NEMA 5-15P	(10) NEMA 5-15R	60°C	YES
AMER	VA4N2100	Rack Transfer Switch	Monitored Unit Level	1U	100-120V	20A	1.9kW (120V)	(2) NEMA 5-20P	(10) NEMA 5-20R	60°C	YES
AMER	VA4N3100	Rack Transfer Switch	Monitored Unit Level	1U	200-240V	30A	4.9kW (208V)	(2) NEMA L6-30P	(1) NEMA L6-30C (Corded Output)	60°C	YES
EMEA	VA7U2100	Rack Transfer Switch	Switched Outlet Level Monitoring	1U	100-240V	16A or 20A	1.9kW (120V), 3.3kW (208V), 3.6kW (230V)	(2) C20 Inlet	(6) Combination Outlet C13 / C19	60°C	YES
EMEA	VA4U2100	Rack Transfer Switch	Monitored Unit Level	1U	100-240V	16A or 20A	1.9kW (120V), 3.3kW (208V), 3.6kW (230V)	(2) C20 Inlet	(12) Combination Outlet C13 / C19	60°C	YES
EMEA	VA7G9201	Rack Transfer Switch	Switched Outlet Level Monitoring	2U	200-240V	32A	7.3kW (230V)	(2) 1P+N+E	(12) Combination Outlet C13 / C19	60°C	YES
EMEA	VA4G9100	Rack Transfer Switch	Monitored Unit Level	1U	200-240V	32A	7.3kW (230V)	(2) 1P+N+E	(12) Combination Outlet C13 / C19	60°C	YES



Vertiv.com | Vertiv Headquarters, 1050 Dearborn Drive, Columbus, OH, 43085, USA

© 2022 Vertiv Group Corp. All rights reserved. Vertiv™ and the Vertiv logo are trademarks or registered trademarks of Vertiv Group Corp. All other names and logos referred to are trade names, trademarks or registered trademarks of their respective owners. While every precaution has been taken to ensure accuracy and completeness here, Vertiv Group Corp. assumes no responsibility, and disclaims all liability, for damages resulting from use of this information or for any errors or omissions. Specifications, rebates and other promotional offers are subject to change at Vertiv's sole discretion upon notice.