

# Classic Battery Cabinet for IEC

For Galaxy VS/VL and Easy UPS 3-Phase Modular

## Installation

GVSCBC7C, GVSCBC7D, GVSCBC7E, GVSCBC10A2, GVSCBC10B2

Latest updates are available on the Schneider Electric website  
1/2024



# Legal Information

The information provided in this document contains general descriptions, technical characteristics and/or recommendations related to products/solutions.

This document is not intended as a substitute for a detailed study or operational and site-specific development or schematic plan. It is not to be used for determining suitability or reliability of the products/solutions for specific user applications. It is the duty of any such user to perform or have any professional expert of its choice (integrator, specifier or the like) perform the appropriate and comprehensive risk analysis, evaluation and testing of the products/solutions with respect to the relevant specific application or use thereof.

The Schneider Electric brand and any trademarks of Schneider Electric SE and its subsidiaries referred to in this document are the property of Schneider Electric SE or its subsidiaries. All other brands may be trademarks of their respective owner.

This document and its content are protected under applicable copyright laws and provided for informative use only. No part of this document may be reproduced or transmitted in any form or by any means (electronic, mechanical, photocopying, recording, or otherwise), for any purpose, without the prior written permission of Schneider Electric.

Schneider Electric does not grant any right or license for commercial use of the document or its content, except for a non-exclusive and personal license to consult it on an "as is" basis.

Schneider Electric reserves the right to make changes or updates with respect to or in the content of this document or the format thereof, at any time without notice.

**To the extent permitted by applicable law, no responsibility or liability is assumed by Schneider Electric and its subsidiaries for any errors or omissions in the informational content of this document, as well as any non-intended use or misuse of the content thereof.**

# Table of Contents

Important Safety Instructions — SAVE THESE	
INSTRUCTIONS .....	5
Safety Precautions .....	6
Electrical Safety .....	8
Battery Safety .....	9
Specifications .....	11
Classic Battery Cabinet Specifications .....	11
Trip Settings .....	12
Recommended Cable Sizes .....	14
Torque Specifications .....	16
Clearance .....	16
Classic Battery Cabinet Shipping Weights and Dimensions .....	17
Classic Battery Cabinet Weights and Dimensions .....	17
Environment .....	17
Compliance .....	17
Installation Procedure .....	18
Prepare for Cables .....	19
Connect the Signal Cables to the Galaxy VS UPS .....	20
Connect the Signal Cables to the Galaxy VL UPS .....	23
Connect the Signal Cables to the Easy UPS 3-Phase Modular .....	27
Connect the Power Cables .....	30
Add Translated Safety Labels to Your Product .....	32
Final Installation .....	33
Decommission or Move the Classic Battery Cabinet to a New Location .....	35



# Important Safety Instructions — SAVE THESE INSTRUCTIONS

Read these instructions carefully and look at the equipment to become familiar with it before trying to install, operate, service or maintain it. The following safety messages may appear throughout this manual or on the equipment to warn of potential hazards or to call attention to information that clarifies or simplifies a procedure.



The addition of this symbol to a “Danger” or “Warning” safety message indicates that an electrical hazard exists which will result in personal injury if the instructions are not followed.



This is the safety alert symbol. It is used to alert you to potential personal injury hazards. Obey all safety messages with this symbol to avoid possible injury or death.

## DANGER

**DANGER** indicates a hazardous situation which, if not avoided, **will result in death or serious injury.**

**Failure to follow these instructions will result in death or serious injury.**

## WARNING

**WARNING** indicates a hazardous situation which, if not avoided, **could result in death or serious injury.**

**Failure to follow these instructions can result in death, serious injury, or equipment damage.**

## CAUTION

**CAUTION** indicates a hazardous situation which, if not avoided, **could result in minor or moderate injury.**

**Failure to follow these instructions can result in injury or equipment damage.**

## NOTICE

**NOTICE** is used to address practices not related to physical injury. The safety alert symbol shall not be used with this type of safety message.

**Failure to follow these instructions can result in equipment damage.**

## Please Note

Electrical equipment should only be installed, operated, serviced, and maintained by qualified personnel. No responsibility is assumed by Schneider Electric for any consequences arising out of the use of this material.

A qualified person is one who has skills and knowledge related to the construction, installation, and operation of electrical equipment and has received safety training to recognize and avoid the hazards involved.

Per IEC 62040-1: "Uninterruptible power systems (UPS) -- Part 1: Safety Requirements," this equipment, including battery access, must be inspected, installed and maintained by a skilled person.

The skilled person is a person with relevant education and experience to enable him or her to perceive risks and to avoid hazards which the equipment can create (reference IEC 62040-1, section 3.102).

## Safety Precautions

### DANGER

#### HAZARD OF ELECTRIC SHOCK, EXPLOSION, OR ARC FLASH

Read all instructions in the installation manual before installing or working on this product.

**Failure to follow these instructions will result in death or serious injury.**

### DANGER

#### HAZARD OF ELECTRIC SHOCK, EXPLOSION, OR ARC FLASH

Do not install the product until all construction work has been completed and the installation room has been cleaned.

**Failure to follow these instructions will result in death or serious injury.**

### DANGER

#### HAZARD OF ELECTRIC SHOCK, EXPLOSION, OR ARC FLASH

The product must be installed according to the specifications and requirements as defined by Schneider Electric. It concerns in particular the external and internal protections (upstream breakers, battery breakers, cabling, etc.) and environmental requirements. No responsibility is assumed by Schneider Electric if these requirements are not respected.

**Failure to follow these instructions will result in death or serious injury.**

### DANGER

#### HAZARD OF ELECTRIC SHOCK, EXPLOSION, OR ARC FLASH

The UPS system must be installed according to local and national regulations. Install the UPS system according to:

- IEC 60364 (including 60364-4-41- protection against electric shock, 60364-4-42 - protection against thermal effect, and 60364-4-43 - protection against overcurrent), **or**
- NEC NFPA 70, **or**
- Canadian Electrical Code (C22.1, Part 1)

depending on which one of the standards apply in your local area.

**Failure to follow these instructions will result in death or serious injury.**

**⚠ ⚠ DANGER**

**HAZARD OF ELECTRIC SHOCK, EXPLOSION, OR ARC FLASH**

- Install the product in a temperature controlled indoor environment free of conductive contaminants and humidity.
- Install the product on a non-flammable, level and solid surface (e.g. concrete) that can support the weight of the system.

**Failure to follow these instructions will result in death or serious injury.**

**⚠ ⚠ DANGER**

**HAZARD OF ELECTRIC SHOCK, EXPLOSION, OR ARC FLASH**

The product is not designed for and must therefore not be installed in the following unusual operating environments:

- Damaging fumes
- Explosive mixtures of dust or gases, corrosive gases, or conductive or radiant heat from other sources
- Moisture, abrasive dust, steam or in an excessively damp environment
- Fungus, insects, vermin
- Salt-laden air or contaminated cooling refrigerant
- Pollution degree higher than 2 according to IEC 60664-1
- Exposure to abnormal vibrations, shocks, and tilting
- Exposure to direct sunlight, heat sources, or strong electromagnetic fields

**Failure to follow these instructions will result in death or serious injury.**

**⚠ ⚠ DANGER**

**HAZARD OF ELECTRIC SHOCK, EXPLOSION, OR ARC FLASH**

Do not drill or cut holes for cables or conduits with the gland plates installed and do not drill or cut holes in close proximity to the UPS system.

**Failure to follow these instructions will result in death or serious injury.**

**⚠ ⚠ WARNING**

**HAZARD OF ARC FLASH**

Do not make mechanical changes to the product (including removal of cabinet parts or drilling/cutting of holes) that are not described in the installation manual.

**Failure to follow these instructions can result in death, serious injury, or equipment damage.**

**NOTICE**

**RISK OF OVERHEATING**

Respect the space requirements around the product and do not cover the ventilation openings when the product is in operation.

**Failure to follow these instructions can result in equipment damage.**

## Electrical Safety

### **DANGER**

#### **HAZARD OF ELECTRIC SHOCK, EXPLOSION, OR ARC FLASH**

- Electrical equipment must be installed, operated, serviced, and maintained only by qualified personnel.
- Apply appropriate personal protective equipment (PPE) and follow safe electrical work practices.
- Turn off all power supplying the UPS system before working on or inside the equipment.
- Before working on the UPS system, check for hazardous voltage between all terminals including the protective earth.
- The UPS contains an internal energy source. Hazardous voltage can be present even when disconnected from the mains supply. Before installing or servicing the UPS system, ensure that the units are OFF and that mains and batteries are disconnected. Wait five minutes before opening the UPS to allow the capacitors to discharge.
- The UPS must be properly earthed/grounded and due to a high leakage current, the earthing/grounding conductor must be connected first.

**Failure to follow these instructions will result in death or serious injury.**

### **DANGER**

#### **HAZARD OF ELECTRIC SHOCK, EXPLOSION, OR ARC FLASH**

In systems where backfeed protection is not part of the standard design, an automatic isolation device (backfeed protection option or other device meeting the requirements of IEC/EN 62040–1 or UL1778 5th Edition – depending on which of the two standards apply to your local area) must be installed to prevent hazardous voltage or energy at the input terminals of the isolation device. The device must open within 15 seconds after the upstream power supply fails and must be rated according to the specifications.

**Failure to follow these instructions will result in death or serious injury.**

When the UPS input is connected through external isolators that, when opened, isolate the neutral or when the automatic backfeed isolation is provided external to the equipment or is connected to an IT power distribution system, a label must be fitted at the UPS input terminals, and on all primary power isolators installed remote from the UPS area and on external access points between such isolators and the UPS, by the user, displaying the following text (or equivalent in a language which is acceptable in the country in which the UPS system is installed):

### **DANGER**

#### **HAZARD OF ELECTRIC SHOCK, EXPLOSION, OR ARC FLASH**

Risk of Voltage Backfeed. Before working on this circuit: Isolate the UPS and check for hazardous voltage between all terminals including the protective earth.

**Failure to follow these instructions will result in death or serious injury.**



## Battery Safety

### **DANGER**

#### **HAZARD OF ELECTRIC SHOCK, EXPLOSION OR ARC FLASH**

- Battery circuit breakers must be installed according to the specifications and requirements as defined by Schneider Electric.
- Servicing of batteries must only be performed or supervised by qualified personnel knowledgeable of batteries and the required precautions. Keep unqualified personnel away from batteries.
- Disconnect charging source prior to connecting or disconnecting battery terminals.
- Do not dispose of batteries in a fire as they can explode.
- Failed batteries can reach temperatures that exceed the burn thresholds for touchable surfaces.
- Do not open, alter, or mutilate batteries. Released electrolyte is harmful to the skin and eyes. It may be toxic.

**Failure to follow these instructions will result in death or serious injury.**

### **DANGER**

#### **HAZARD OF ELECTRIC SHOCK, EXPLOSION, OR ARC FLASH**

Batteries can present a risk of electric shock and high short-circuit current. The following precautions must be observed when working on batteries:

- Remove watches, rings, or other metal objects.
- Use tools with insulated handles.
- Wear protective glasses, gloves, and boots.
- Do not lay tools or metal parts on top of batteries.
- Disconnect the charging source prior to connecting or disconnecting battery terminals.
- Determine if the battery is inadvertently grounded. If inadvertently grounded, remove source from ground. Contact with any part of a grounded battery can result in electric shock and burns by high short-circuit current. The likelihood of such shock can be reduced if such grounds are removed during installation and maintenance by a skilled person (applicable to equipment and remote battery supplies not having a grounded supply circuit).

**Failure to follow these instructions will result in death or serious injury.**

### **DANGER**

#### **HAZARD OF ELECTRIC SHOCK, EXPLOSION, OR ARC FLASH**

When replacing batteries, always replace with the same type and number of batteries or battery packs. Refer to the label in the classic battery cabinet for information on batteries in your system.

**Failure to follow these instructions will result in death or serious injury.**

**▲ CAUTION****RISK OF EQUIPMENT DAMAGE**

- Mount the batteries in the UPS system, but do not connect the batteries until the UPS system is ready to be powered up. The time duration from battery connection until the UPS system is powered up must not exceed 72 hours or 3 days.
- Batteries must not be stored more than six months due to the requirement of recharging. If the UPS system remains de-energized for a long period, we recommend that you energize the UPS system for a period of 24 hours at least once every month. This charges the batteries, thus avoiding irreversible damage.

**Failure to follow these instructions can result in injury or equipment damage.**

# Specifications

<b>NOTICE</b>
<b>HAZARD OF EQUIPMENT DAMAGE</b>
Refer to the UPS installation manual for detailed specifications for the UPS system.
<b>Failure to follow these instructions can result in equipment damage.</b>

## Classic Battery Cabinet Specifications

<b>⚠️ DANGER</b>
<b>HAZARD OF ELECTRIC SHOCK, EXPLOSION OR ARC FLASH</b>
The classic battery cabinet must only be used with the Galaxy VS UPS, the Galaxy VL UPS, or the Easy UPS 3-Phase Modular.
<b>Failure to follow these instructions will result in death or serious injury.</b>

**NOTE:** Up to two classic battery cabinets (GVSCBC7C, GVSCBC7D, GVSCBC7E, GVSCBC10A2, or GVSCBC10B2) can be connected to the Galaxy VS UPS.

**NOTE:** Minimum two classic battery cabinets and up to four classic battery cabinets (GVSCBC10A2 or GVSCBC10B2) can be connected to the Galaxy VL UPS.

**NOTE:** Up to four classic battery cabinets (GVSCBC7C, GVSCBC7D, GVSCBC7E, GVSCBC10A2, or GVSCBC10B2) can be connected to the Easy UPS 3-Phase Modular.

Commercial reference	Battery type	Number of battery blocks
GVSCBC7C	XP12V1800 <sup>1</sup> or XP12-240	36
GVSCBC7D	XP12-150	40
GVSCBC7E	XP12-150	46
GVSCBC10A2	XP12-240	48
GVSCBC10B2	XP12-350	40

1. No longer standard. Can be ordered as Make to Order with specified lead time.

## Trip Settings

Trip settings must be controlled during installation. Set the trip settings according to the relevant table below.

### GVSCBC7C

UPS rating	20-50 kW			60 kW			80 kW			100 kW			
Power factor	0.8	0.9	1	0.8	0.9	1	0.8	0.9	1	0.8	0.9	1	
Breaker type	C25S3D + C253MG250D										NA		
Ir setting	175			200			250			250			
Im setting	1250												

### GVSCBC7D

UPS rating	20 kW			30 kW			40-50 kW			60 kW			
Power factor	0.8	0.9	1	0.8	0.9	1	0.8	0.9	1	0.8	0.9	1	
Breaker type	C10S3D + C103MG080												
Ir setting	56			72			80			80		NA	
Im setting	400												

### GVSCBC7E

UPS rating	20-50 kW			60 kW			80 kW		
Power factor	0.8	0.9	1	0.8	0.9	1	0.8	0.9	1
Breaker type	C25S3D + C253MG200D								
Ir setting	140			160			200		
Im setting	1000								

### GVSCBC10A2

UPS rating	20-60 kW			80 kW			100 kW			120 kW			150 kW		
Power factor	0.8	0.9	1	0.8	0.9	1	0.8	0.9	1	0.8	0.9	1	0.8	0.9	1
Breaker type	C25S3D + C253MG250D														NA
Ir setting	175			175	175	200	200	225	225	225	250	250	250		
Im setting	1250														

UPS rating	200 kW	250 kW	300 kW	350 kW	400 kW	450 kW	500 kW
Power factor	1						
Breaker type	C25S3D + C253MG250D						
Number of classic battery cabinets	2 x GVSCBC10-A2	2 x GVSCBC10-A2	3 x GVSCBC10-A2	3 x GVSCBC10-A2	4 x GVSCBC10-A2	4 x GVSCBC10-A2	4 x GVSCBC10-A2

<b>UPS rating</b>	<b>200 kW</b>	<b>250 kW</b>	<b>300 kW</b>	<b>350 kW</b>	<b>400 kW</b>	<b>450 kW</b>	<b>500 kW</b>
<b>Power factor</b>	<b>1</b>						
<b>Ir setting</b>	225	250	225	250	225	250	250
<b>Im setting</b>	1250						

## GVSCBC10B2

<b>UPS rating</b>	<b>20-80 kW</b>			<b>100 kW</b>			<b>120 kW</b>			<b>150 kW</b>			
<b>Power factor</b>	<b>0.8</b>	<b>0.9</b>	<b>1</b>	<b>0.8</b>	<b>0.9</b>	<b>1</b>	<b>0.8</b>	<b>0.9</b>	<b>1</b>	<b>0.8</b>	<b>0.9</b>	<b>1</b>	
<b>Breaker type</b>	C40S3TM320D												
<b>Ir setting</b>	224			224	256	288	288	320			320		
<b>Im setting</b>	1500												

<b>UPS rating</b>	<b>200 kW</b>	<b>250 kW</b>	<b>300 kW</b>	<b>350 kW</b>	<b>400 kW</b>	<b>450 kW</b>	<b>500 kW</b>
<b>Power factor</b>	<b>1</b>						
<b>Breaker type</b>	C40S3TM320D						
<b>Number of classic battery cabinets</b>	2 x GVSCBC10-B2	2 x GVSCBC10-B2	3 x GVSCBC10-B2	3 x GVSCBC10-B2	4 x GVSCBC10-B2	4 x GVSCBC10-B2	4 x GVSCBC10-B2
<b>Ir setting</b>	288	320	288	320	288	320	320
<b>Im setting</b>	1500						

## Recommended Cable Sizes

**⚡⚠ DANGER**

**HAZARD OF ELECTRIC SHOCK, EXPLOSION, OR ARC FLASH**

All wiring must comply with all applicable national and/or electrical codes. The maximum allowable cable size is 95 mm<sup>2</sup>.

**Failure to follow these instructions will result in death or serious injury.**

Cable sizes in this manual are based on table B.52.3 (52-C2) of IEC 60364-5-52 with the following assertions:

- 90 °C conductors
- An ambient temperature of 30 °C
- Use of copper conductors
- Installation method C

Protective Earth (PE) cables are sized in accordance with table 54.3 of IEC 60364-4-54, Article 543.

If the ambient temperature is greater than 30 °C, larger conductors are to be selected in accordance with the correction factors of the IEC.

### GVSCBC7C

UPS rating	20-60 kW			80 kW			100 kW		
Power factor	0.8	0.9	1	0.8	0.9	1	0.8	0.9	1
DC+/DC- (mm <sup>2</sup> )	50			70			70	NA	
DC PE (mm <sup>2</sup> )	25			35			35		

### GVSCBC7D

UPS rating	20-30 kW			40-50 kW			60 kW		
Power factor	0.8	0.9	1	0.8	0.9	1	0.8	0.9	1
DC+/DC- (mm <sup>2</sup> )	16			35			35		
DC PE (mm <sup>2</sup> )	10			16			16		

### GVSCBC7E

UPS rating	20-60 kW			80 kW		
Power factor	0.8	0.9	1	0.8	0.9	1
DC+/DC- (mm <sup>2</sup> )	35			50		
DC PE (mm <sup>2</sup> )	16			25		

## GVSCBC10A2

UPS rating	20-80 kW			100-120 kW			150 kW		
Power factor	0.8	0.9	1	0.8	0.9	1	0.8	0.9	1
DC+/DC- (mm <sup>2</sup> )	50			70			70		NA
DC PE (mm <sup>2</sup> )	25			35			35		

UPS rating	200 kW	250 kW	300 kW	350 kW	400 kW	450 kW	500 kW
Power factor	1						
Number of classic battery cabinets	2 x GVSCBC10-A2	2 x GVSCBC10-A2	3 x GVSCBC10-A2	3 x GVSCBC10-A2	4 x GVSCBC10-A2	4 x GVSCBC10-A2	4 x GVSCBC10-A2
DC+/DC- (mm <sup>2</sup> )	70						
DC PE (mm <sup>2</sup> )	35						

## GVSCBC10B2

UPS rating	20-60 kW			80-100 kW			120-150 kW		
Power factor	0.8	0.9	1	0.8	0.9	1	0.8	0.9	1
DC+/DC- (mm <sup>2</sup> )	50			70			95		
DC PE (mm <sup>2</sup> )	25			35			50		

UPS rating	200 kW	250 kW	300 kW	350 kW	400 kW	450 kW	500 kW
Power factor	1						
Number of classic battery cabinets	2 x GVSCBC10-B2	2 x GVSCBC10-B2	3 x GVSCBC10-B2	3 x GVSCBC10-B2	4 x GVSCBC10-B2	4 x GVSCBC10-B2	4 x GVSCBC10-B2
DC+/DC- (mm <sup>2</sup> )	70	95					
DC PE (mm <sup>2</sup> )	35	50					

## Torque Specifications

Bolt size	Torque
M4	1.7 Nm
M5	2.2 Nm
M6	5 Nm
M8	17.5 Nm
M10	30 Nm
M12	50 Nm

## Clearance

**NOTE:** Clearance dimensions are published for airflow and service access only. Consult with the local safety codes and standards for additional requirements in your local area.

**NOTE:** The room should be ventilated to prevent the concentration of the dihydrogen generated by the battery cabinet. Recommended minimum airflow: 2.41 m<sup>3</sup>/h.

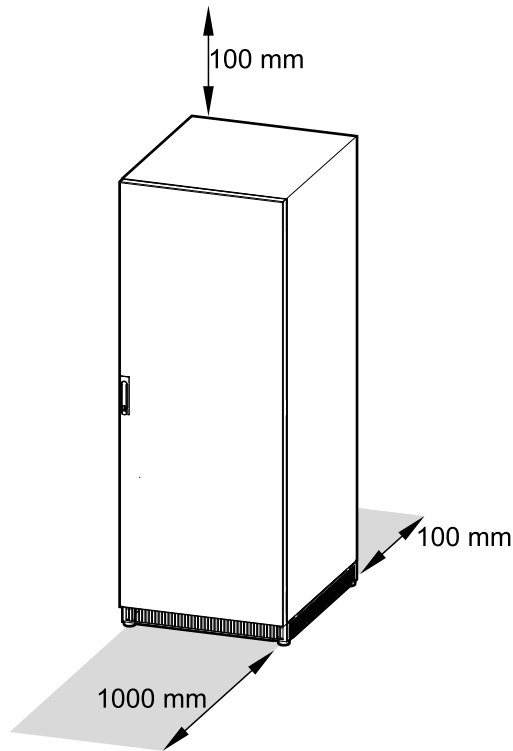



## Classic Battery Cabinet Shipping Weights and Dimensions

Commercial reference	Weight kg	Height mm	Width mm	Depth mm
GVSCBC7C	920	1980	815	970
GVSCBC7D	589	1980	815	970
GVSCBC7E	810	1980	815	970
GVSCBC10A2	1300	1980	1130	970
GVSCBC10B2	1532	1980	1130	970

## Classic Battery Cabinet Weights and Dimensions

Commercial reference	Weight kg	Height mm	Width mm	Depth mm
GVSCBC7C	900	1900	710	845
GVSCBC7D	569	1900	710	845
GVSCBC7E	790	1900	710	845
GVSCBC10A2	1102	1900	1010	845
GVSCBC10B2	1368	1900	1010	845

## Environment

	Operating	Storage
Temperature	0 °C to 40 °C	-15 °C to 40 °C
Relative humidity	0-95% non-condensing	10-80% non-condensing
Elevation	0-1000 m	
Protection class	IP20	
Color	RAL 9003, gloss level 85%	

## Compliance

Safety	IEC 62040-1: 2017, Edition 2.0, Uninterruptible Power Systems (UPS) - Part 1: Safety requirements
Performance	IEC 62040-3: 2011-03, 2nd edition Uninterruptible Power Systems (UPS) - Part 3: Method of specifying the performance and test requirements
Environmental	IEC 62040-4: 2013-04, 1st edition Uninterruptible Power Systems (UPS) - Part 4: Environmental aspects – Requirements and reporting
Markings	CE
Earthing system	TN-C, TN-S, TT
Overvoltage category	OVCIII
Protective class	I
Pollution degree	2

# Installation Procedure

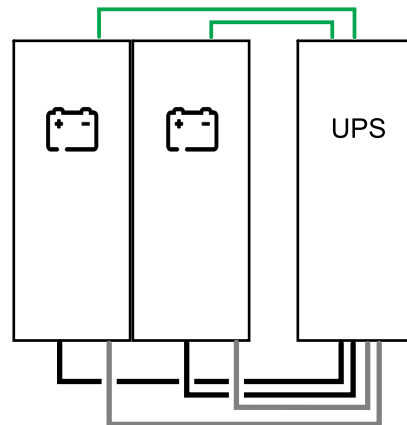

- Signal cable
- Power cable
- PE cable

**NOTE:** The distance between the battery bank and the UPS must not exceed 200 m. Contact Schneider Electric for installations with a longer distance.

1. Prepare for Cables, page 19.
2. Perform one of the following:
  - Connect the Signal Cables to the Galaxy VS UPS, page 20, or
  - Connect the Signal Cables to the Galaxy VL UPS, page 23, or
  - Connect the Signal Cables to the Easy UPS 3-Phase Modular, page 27.
3. Connect the Power Cables, page 30.
4. Add Translated Safety Labels to Your Product, page 32.
5. Final Installation, page 33.

**Post-requisite:** For moving or decommissioning the classic battery cabinet after installation has been completed, please see [Decommission or Move the Classic Battery Cabinet to a New Location](#), page 35.

## Prepare for Cables

1. Open the door(s). On GVSCBC10A2 and GVSCBC10B2, remove two screws to open the left door.
2. Lockout/Tagout the battery breaker in the OFF (open) position.
3. Remove the breaker protection plates.

**GVSCBC7C, GVSCBC7D, GVSCBC7E**

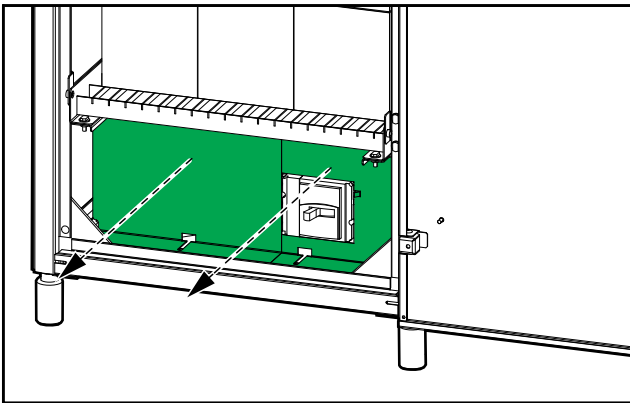

**GVSCBC10A2, GVSCBC10B2**

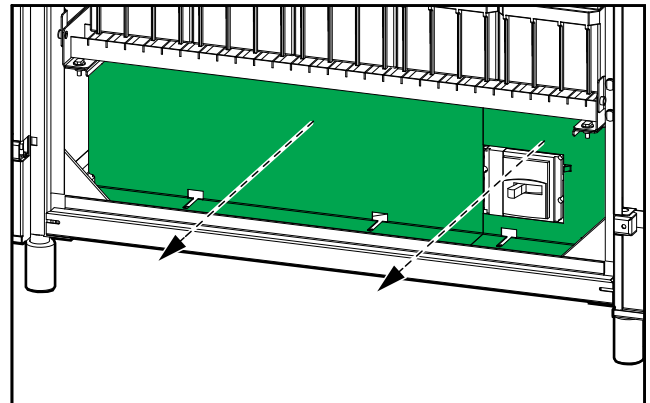

4. Remove the kit with copper bars/cables from the classic battery cabinet. Save for interconnection of the batteries – see [Connect the Power Cables](#), page 30.

# Connect the Signal Cables to the Galaxy VS UPS

**NOTE:** Route the signal cables separately from the power cables to ensure sufficient isolation.

**NOTE:** Use double isolated signal cables. The signal cables must have a minimum rating of 600 V.

1. Install the temperature sensor provided with the UPS in the top of the classic battery cabinet.

## **⚠️ ⚠️ WARNING**

### **HAZARD OF FIRE**

Position the temperature sensor as described to ensure correct temperature measurements.

**Failure to follow these instructions can result in death, serious injury, or equipment damage.**

GVSCBC7C, GVSCBC7D, GVSCBC7E

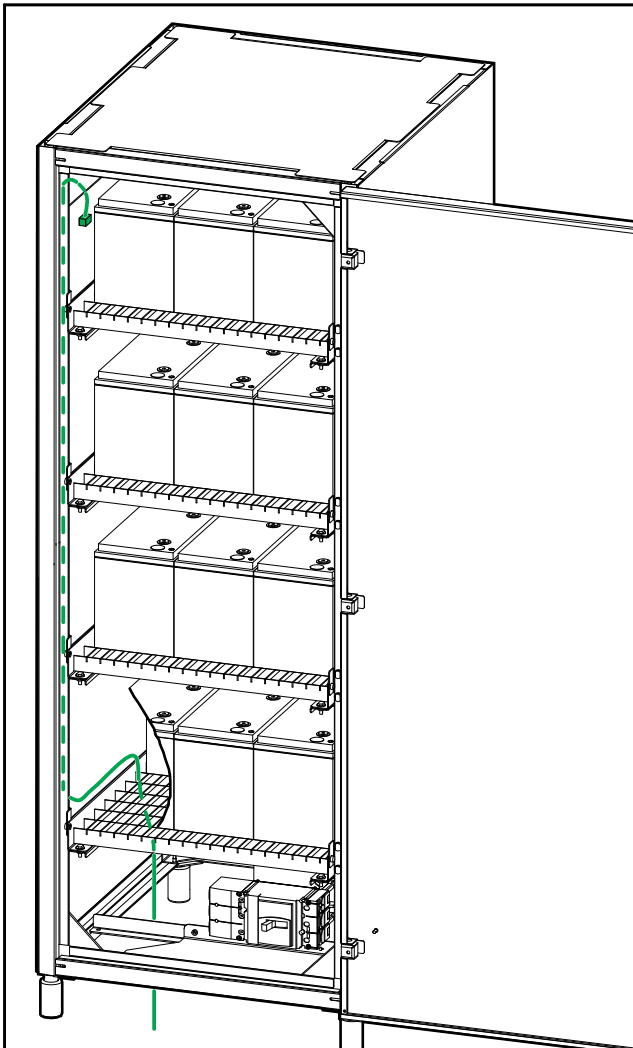

GVSCBC10A2, GVSCBC10B2

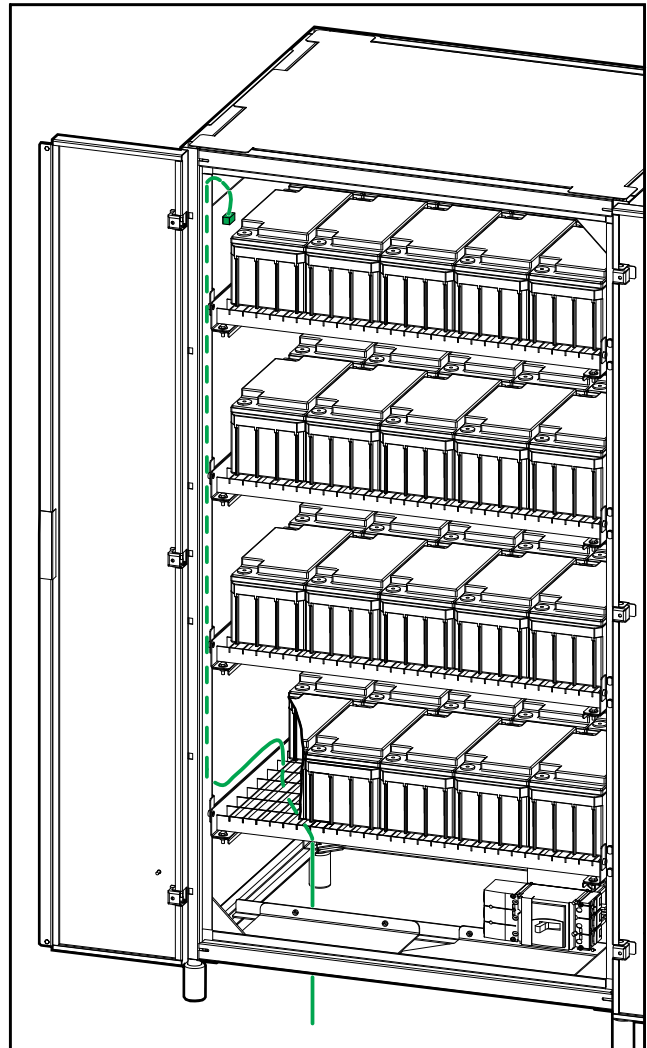

2. Route the battery temperature sensor cables through the bottom of the classic battery cabinet to the UPS and connect as shown.

**NOTE:** One temperature sensor is provided with the UPS. Contact Schneider Electric if you want to buy an additional temperature sensor (0J-0M-1160).

**NOTE:** The battery temperature sensor cables are considered Class 2 and SELV. Class 2 and SELV circuits must be double isolated from the primary circuitry.

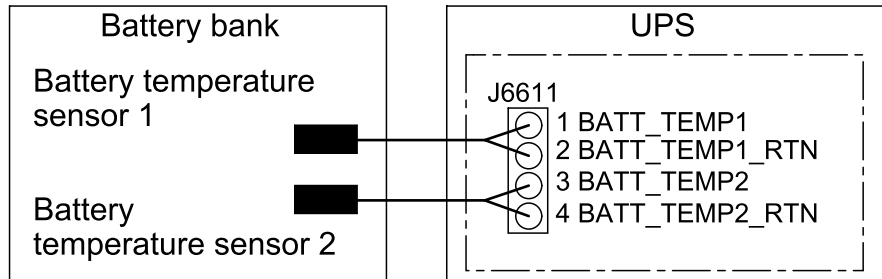

3. Remove the cover on the battery breaker.
4. Connect the signal cables to the battery breaker:
  - a. Connect the signal cables to the AUX switch.
  - b. Connect the signal cables to the undervoltage trip coil.
  - c. Route the signal cables out through the lower opening of the battery breaker.

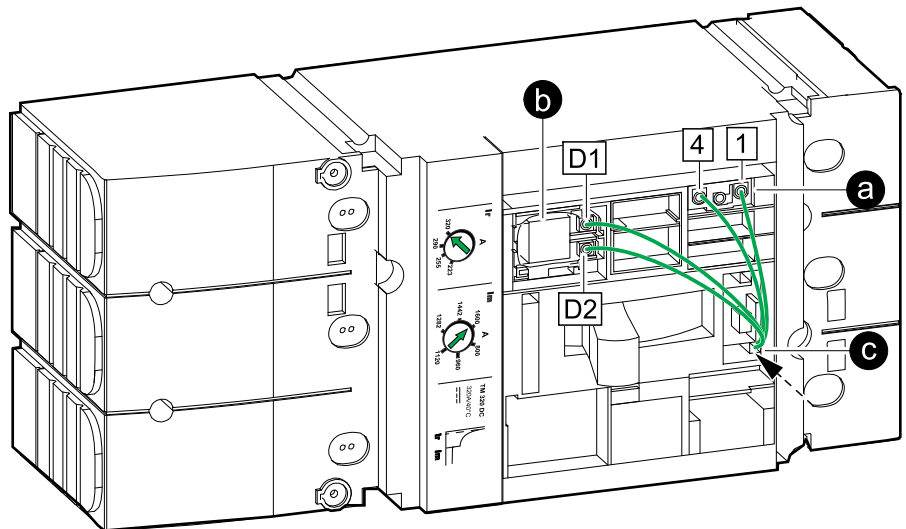

- Route the signal cables from behind the battery breaker and out through the bottom of the classic battery cabinet.

**Rear View of the Battery Breaker**

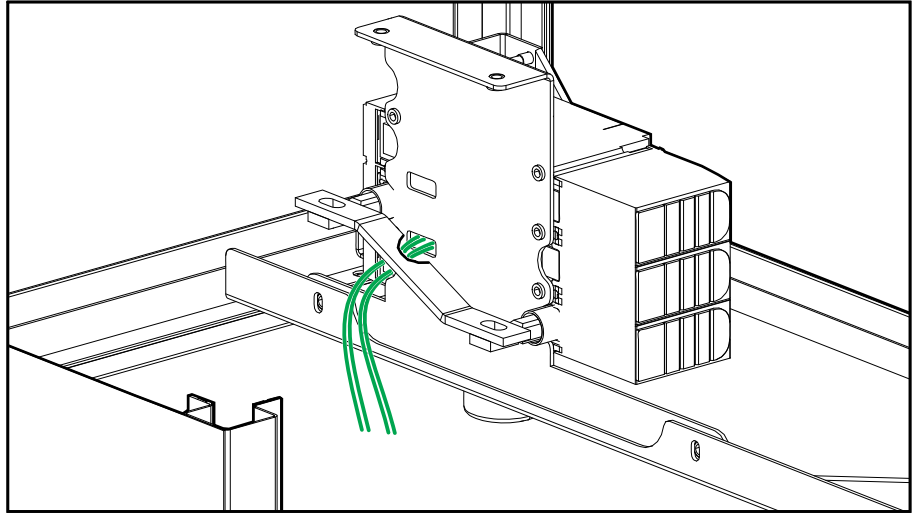

- Reinstall the cover on the battery breaker.
- Connect the signal cables in the UPS as shown.

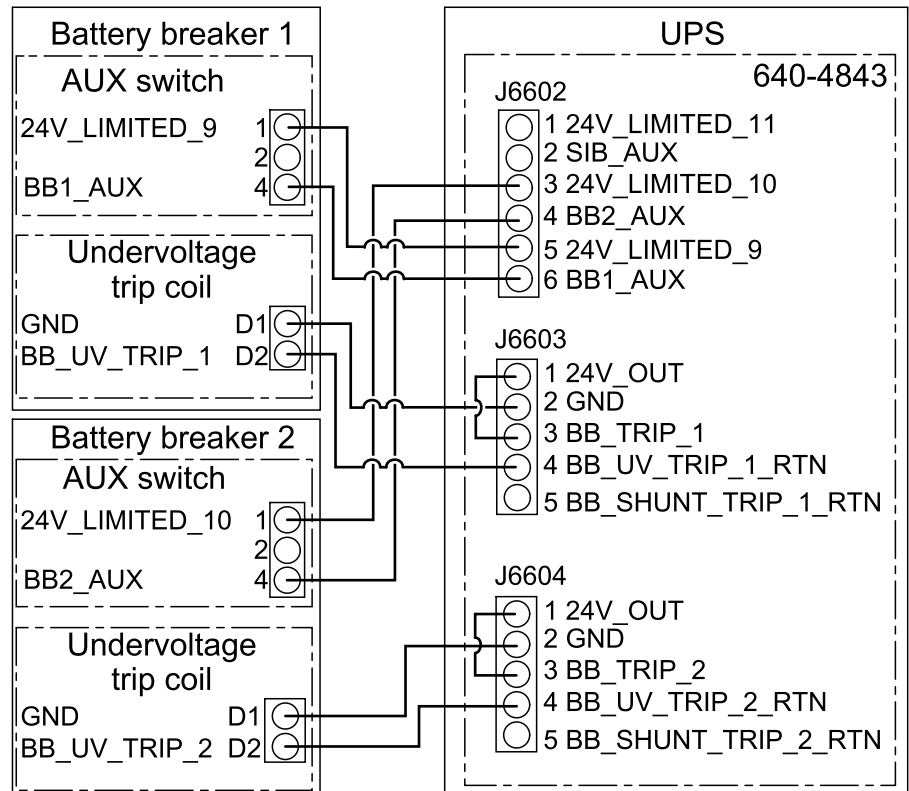

# Connect the Signal Cables to the Galaxy VL UPS

**NOTE:** Route the signal cables separately from the power cables to ensure sufficient isolation.

**NOTE:** Use double isolated signal cables. The signal cables must have a minimum rating of 600 V.

1. Install the temperature sensor(s) 0M-1160 provided with the UPS in the top of the classic battery cabinet(s).

## ⚠️ ⚠️ WARNING

### HAZARD OF FIRE

Position the temperature sensor as described to ensure correct temperature measurements.

**Failure to follow these instructions can result in death, serious injury, or equipment damage.**

### GVSCBC10A2, GVSCBC10B2

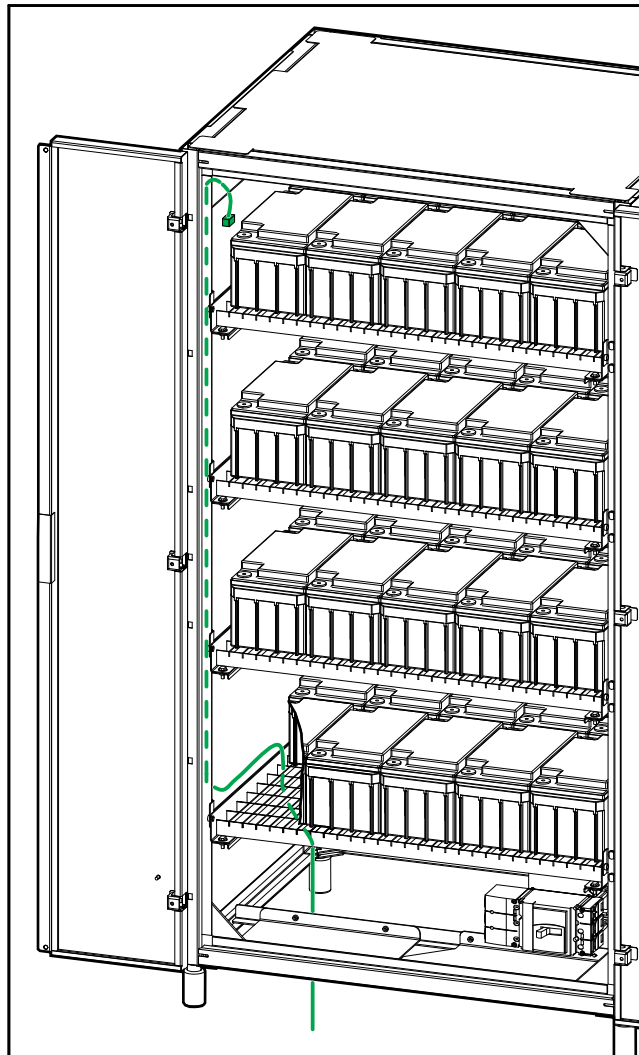

2. Route the battery temperature sensor cables through the bottom of the classic battery cabinet to the UPS and connect as shown.

**NOTE:** Two temperature sensors are provided with the UPS.

**NOTE:** The battery temperature sensor cables are considered Class 2 and SELV. Class 2 and SELV circuits must be double isolated from the primary circuitry.

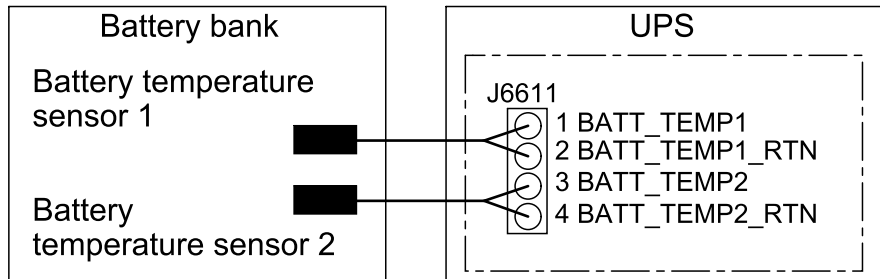

3. Remove the cover on the battery breaker.
4. Connect the signal cables to the battery breaker:
  - a. Connect the signal cables to the AUX switch.
  - b. Connect the signal cables to the undervoltage trip coil.
  - c. Route the signal cables out through the lower opening of the battery breaker.

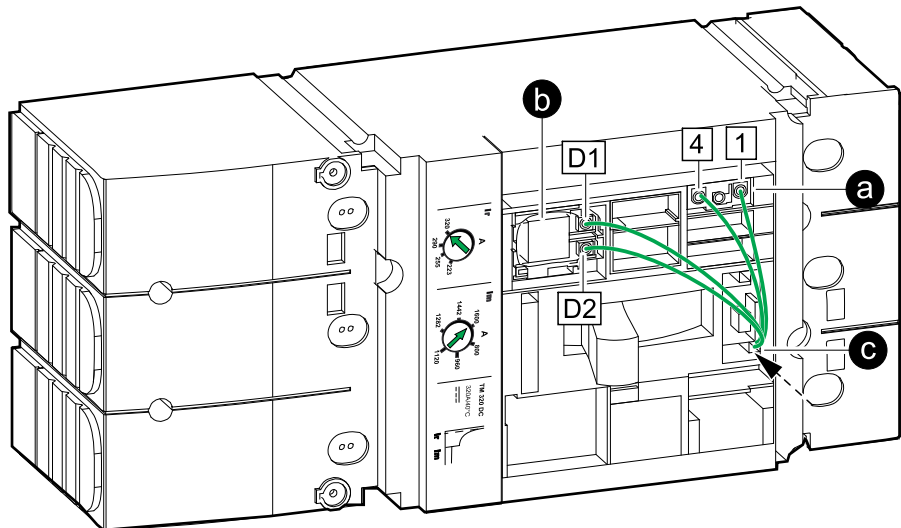



5. Route the signal cables from behind the battery breaker and out through the bottom of the classic battery cabinet.

#### Rear View of the Battery Breaker

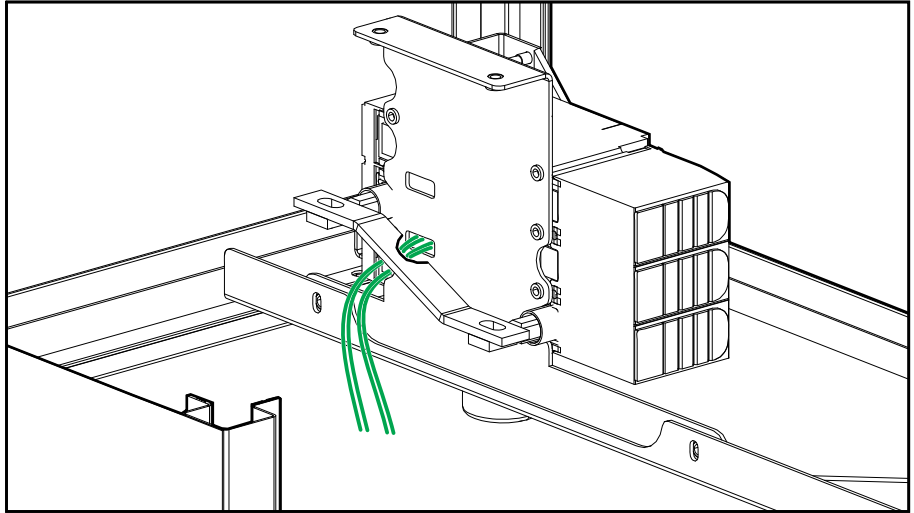

6. Reinstall the cover on the battery breaker.

7. Connect the signal cables in the UPS as shown.

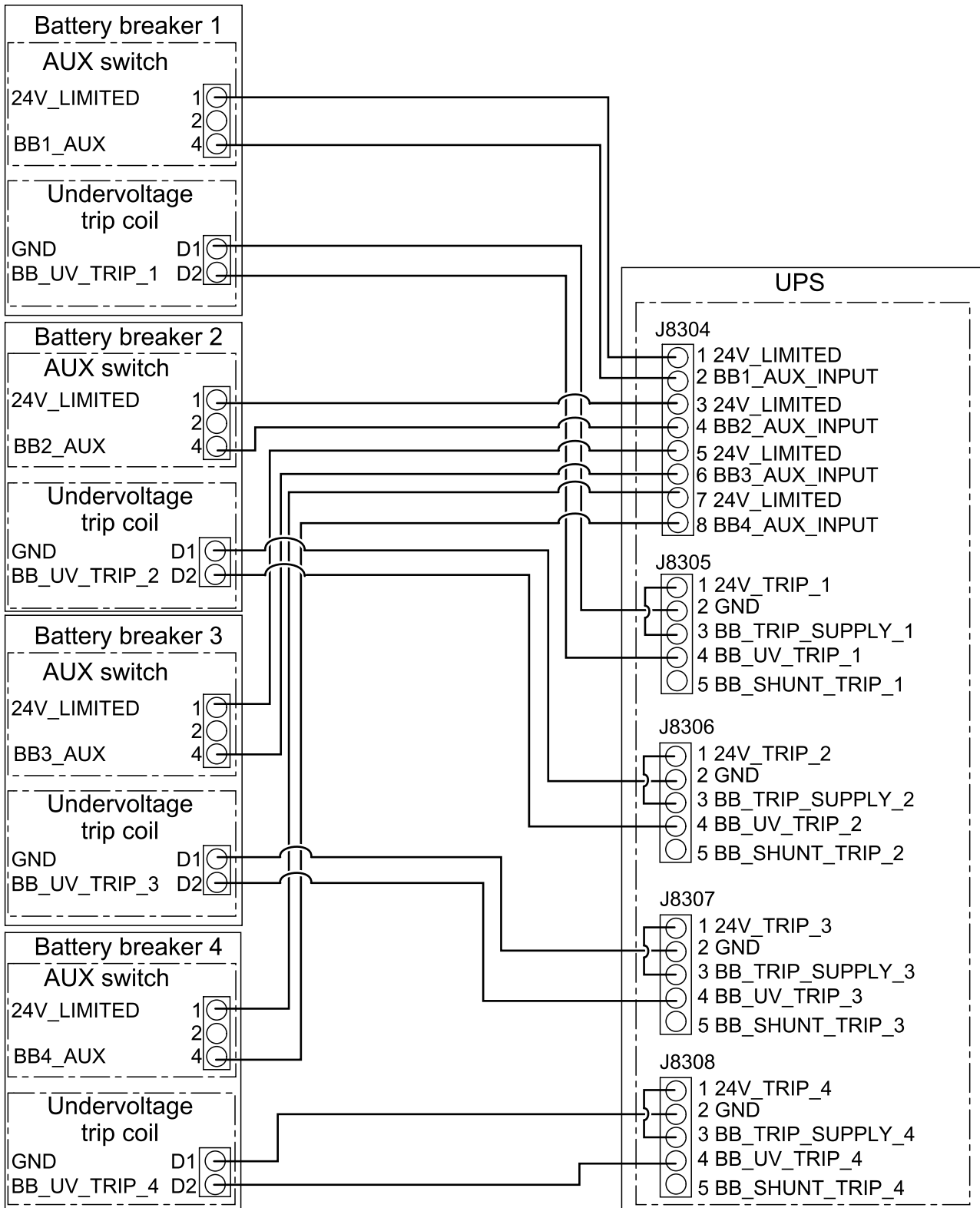

# Connect the Signal Cables to the Easy UPS 3-Phase Modular

**NOTE:** Route the signal cables separately from the power cables to ensure sufficient isolation.

**NOTE:** Use double isolated signal cables. The signal cables must have a minimum rating of 600 V.

1. Install the battery temperature sensor(s) (not provided).

**NOTE:** Temperature sensors (SP3OPT006) are available as an optional kit.

## **⚠️ ⚠️ WARNING**

### **HAZARD OF FIRE**

Position the temperature sensor as described to ensure correct temperature measurements.

**Failure to follow these instructions can result in death, serious injury, or equipment damage.**

GVSCBC7C, GVSCBC7D, GVSCBC7E

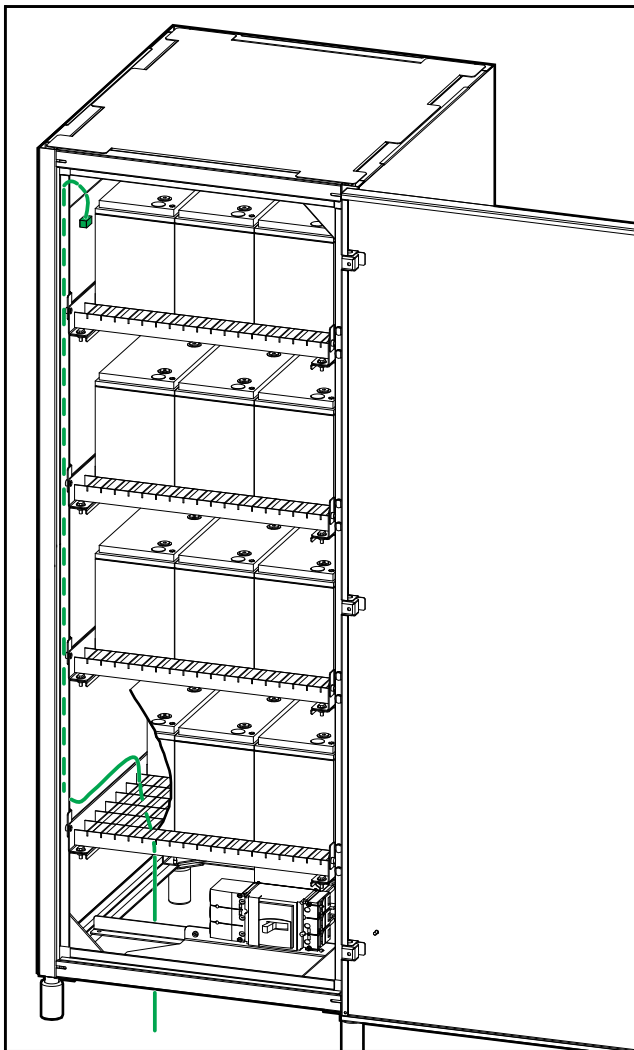

GVSCBC10A2, GVSCBC10B2

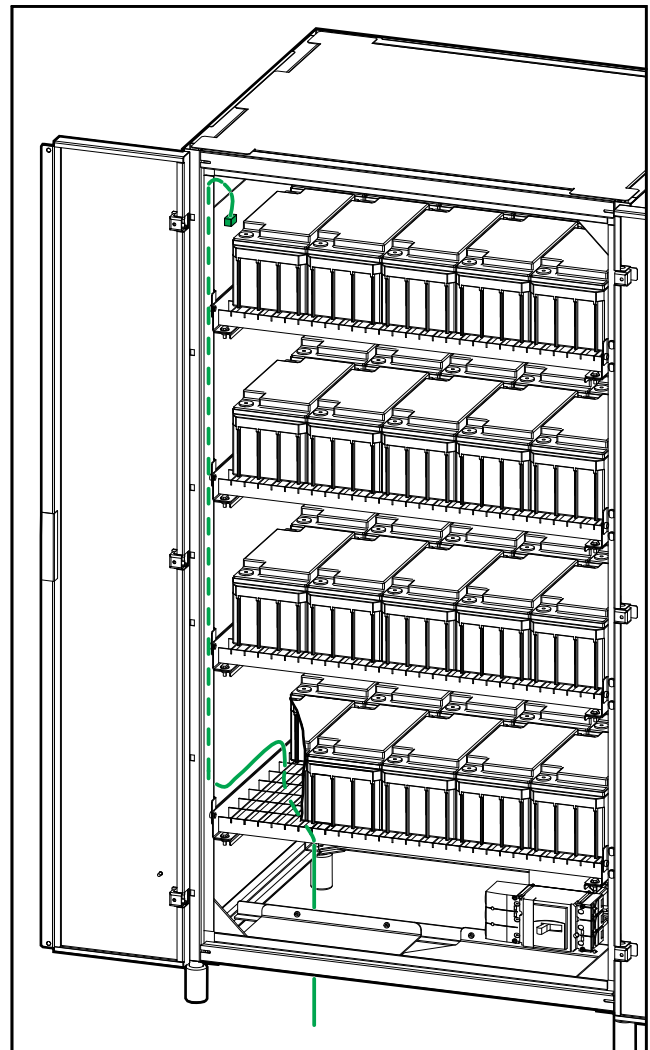

2. Route the battery temperature sensor cables through the bottom of the classic battery cabinet to the UPS and connect as shown.

**NOTE:** The battery temperature sensor cables are considered Class 2 and SELV. Class 2 and SELV circuits must be double isolated from the primary circuitry.

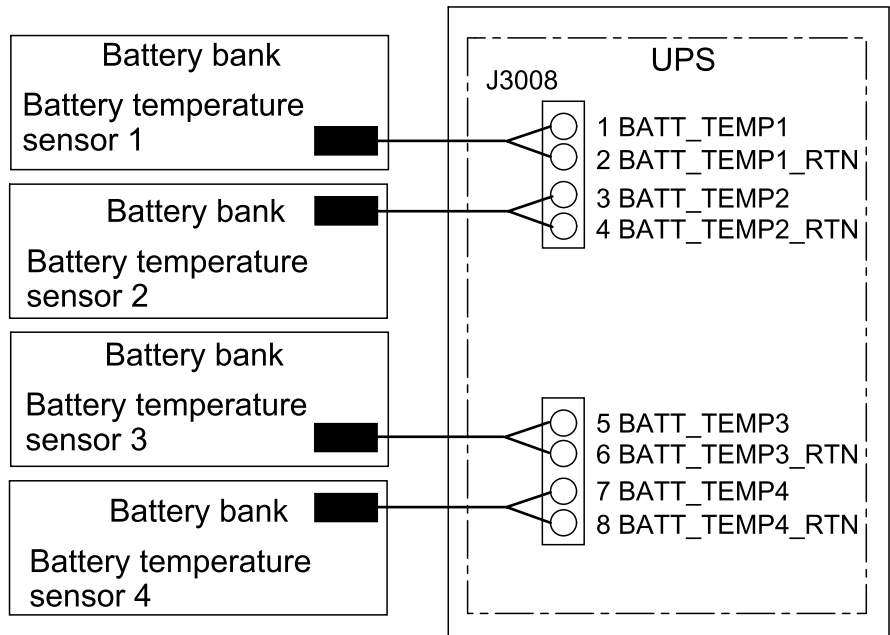

3. Remove the cover on the battery breaker.
4. Connect the signal cables to the battery breaker:
  - a. Connect the signal cables to the AUX switch.
  - b. Connect the signal cables to the undervoltage trip coil.
  - c. Route the signal cables out through the lower opening of the battery breaker.

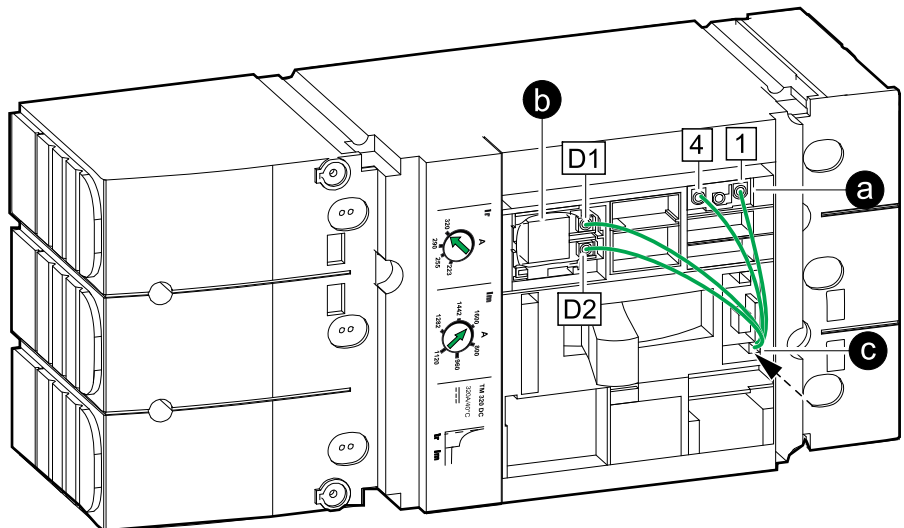



# Connect the Power Cables

## ⚡⚠ DANGER

### HAZARD OF ELECTRIC SHOCK, EXPLOSION, OR ARC FLASH

Perform a total power off of the UPS before connecting the DC cables and battery cables to the classic battery cabinet.

**Failure to follow these instructions will result in death or serious injury.**

1. Remove the terminal cover from the left side of the battery breaker.

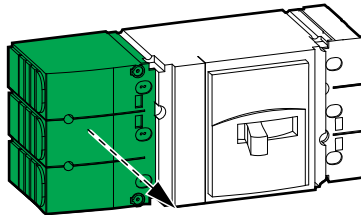

2. Route the PE cable through the bottom of the classic battery cabinet and connect the PE cable.

GVSCBC7C, GVSCBC7D, GVSCBC7E

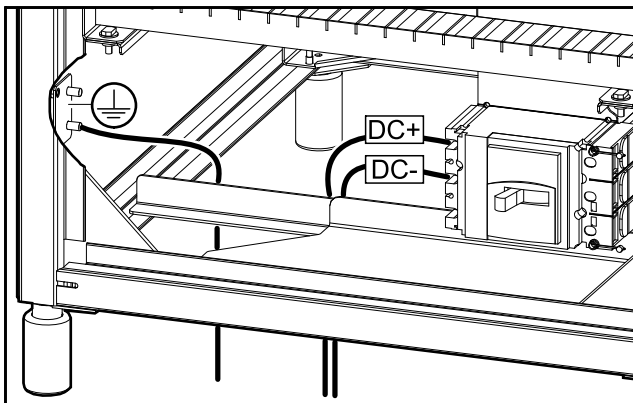

GVSCBC10A2, GVSCBC10B2

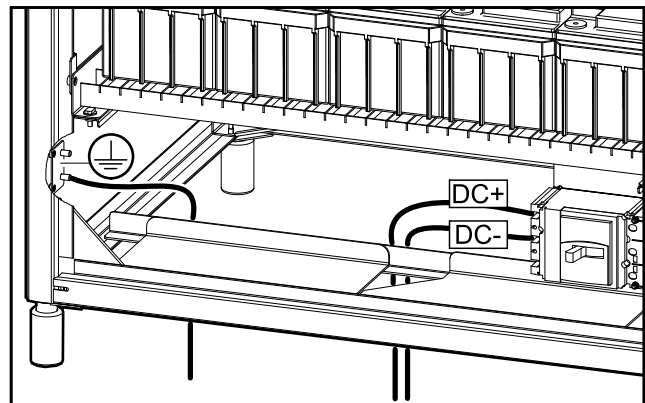

3. Route the DC cables through the bottom of the classic battery cabinet and connect the DC cables (DC+, DC-). Use lock washers (not provided) when connecting the DC cables.
4. Reinstall the terminal cover on the left side of the battery breaker.

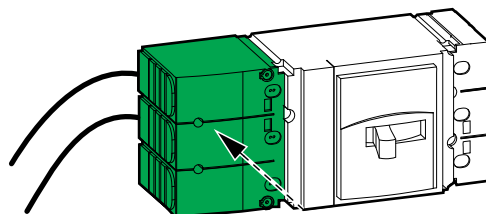

5. Reinstall the breaker protection plates.

6. Interconnect the batteries on each shelf in the classic battery cabinet(s) with the provided copper bars or cables and connect to the right side of the battery breaker. Refer to the connection diagram on the inside of the front door of the classic battery cabinet.

 **DANGER****HAZARD OF ELECTRIC SHOCK, EXPLOSION, OR ARC FLASH**

Batteries can present a risk of electric shock and high short-circuit current. The following precautions must be observed when working on batteries:

- Remove watches, rings, or other metal objects.
- Use tools with insulated handles.
- Wear protective glasses, gloves, and boots.
- Do not lay tools or metal parts on top of batteries.
- Disconnect the charging source prior to connecting or disconnecting battery terminals.
- Determine if the battery is inadvertently grounded. If inadvertently grounded, remove source from ground. Contact with any part of a grounded battery can result in electric shock and burns by high short-circuit current. The likelihood of such shock can be reduced if such grounds are removed during installation and maintenance by a skilled person (applicable to equipment and remote battery supplies not having a grounded supply circuit).

**Failure to follow these instructions will result in death or serious injury.**

## Add Translated Safety Labels to Your Product

The safety labels on your product are in English and French. Sheets with translated safety labels are provided with your product.

1. Find the sheets with translated safety labels provided with your product.
2. Check which 885-XXX numbers are on the sheet with translated safety labels.
3. Locate the safety labels on your product that match the translated safety labels on the sheet – look for the 885-XXX numbers.
4. Add the replacement safety label in your preferred language to your product on top of the existing French safety label.



## Final Installation

1. Install the provided kick plates on the front, rear, and sides of the classic battery cabinet.

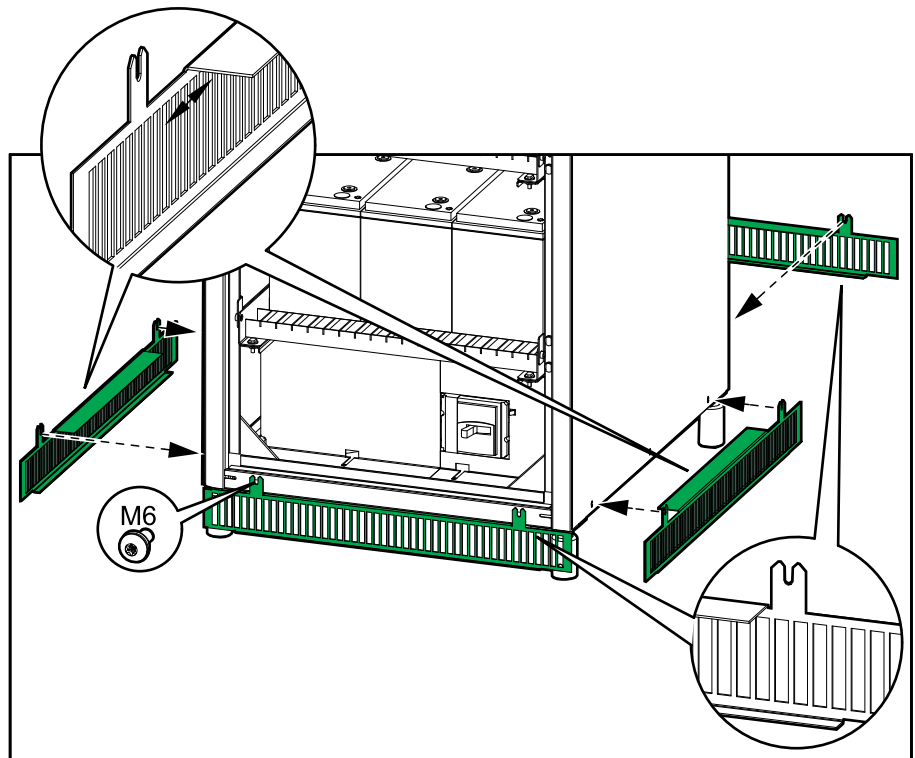

**NOTE:** Only remove the kick plates when following the procedure for decommissioning or moving the classic battery cabinet. See [Decommission or Move the Classic Battery Cabinet to a New Location](#), page 35 for details.

2. Close the door(s). On GVSCBC10A2 and GVSCBC10B2, install two screws to close the left door.

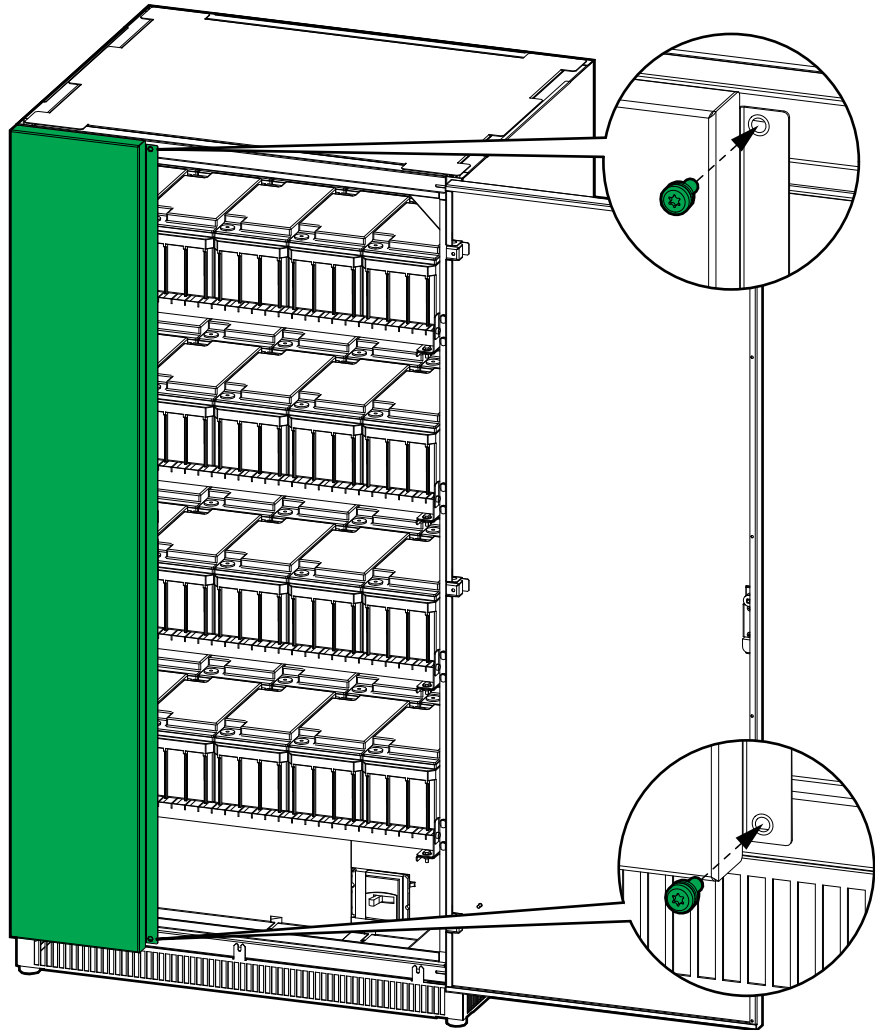
**GVSCBC10A2, GVSCBC10B2**

# Decommission or Move the Classic Battery Cabinet to a New Location

1. Open the door(s). On GVSCBC10A2 and GVSCBC10B2, remove two screws to open the left door.
2. Lockout/Tagout the battery breaker in the OFF (open) position.
3. Remove the breaker protection plates.

**GVSCBC7C, GVSCBC7D, GVSCBC7E**

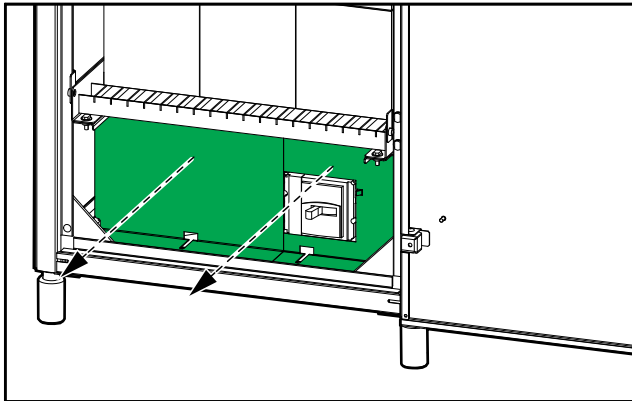

**GVSCBC10A2, GVSCBC10B2**

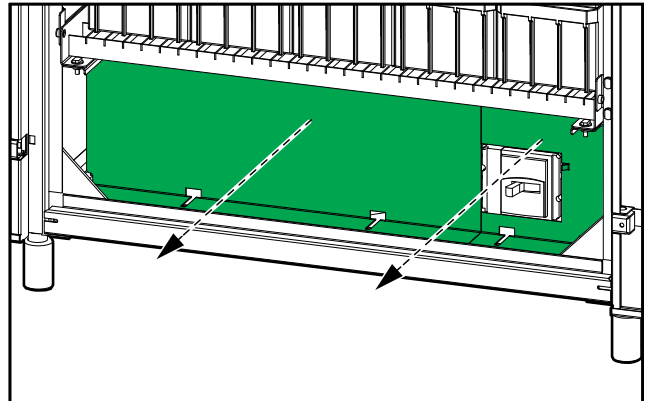

4. Remove the terminal cover from the left side of the battery breaker.

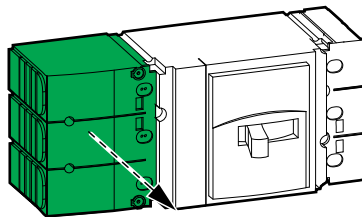

5. Disconnect and remove the DC cables and PE cable from the battery breaker.

**GVSCBC7C, GVSCBC7D, GVSCBC7E**

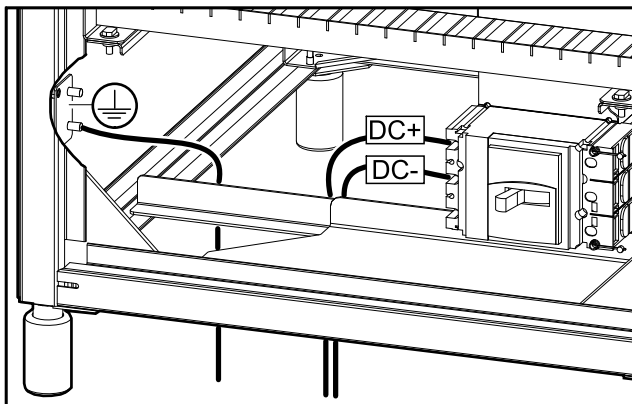

**GVSCBC10A2, GVSCBC10B2**

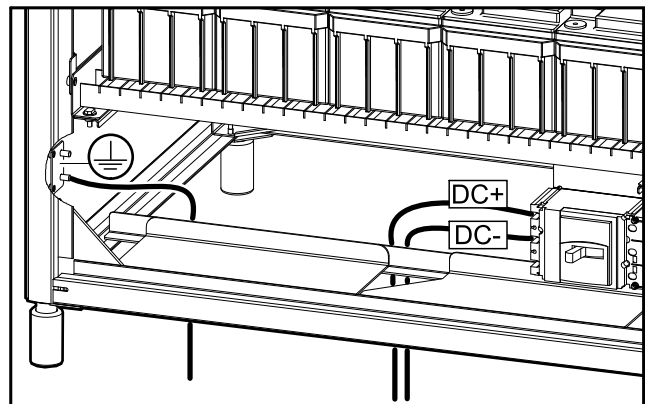

6. Disconnect and remove the interconnection copper bars or interconnection cables between the batteries on each shelf. Disconnect and remove the battery cables from the right side of the battery breaker. Refer to the connection diagram on the inside of the front door of the classic battery cabinet.

**⚠️⚠️ DANGER**

**HAZARD OF ELECTRIC SHOCK, EXPLOSION, OR ARC FLASH**

Batteries can present a risk of electric shock and high short-circuit current. The following precautions must be observed when working on batteries:

- Remove watches, rings, or other metal objects.
- Use tools with insulated handles.
- Wear protective glasses, gloves, and boots.
- Do not lay tools or metal parts on top of batteries.
- Disconnect the charging source prior to connecting or disconnecting battery terminals.
- Determine if the battery is inadvertently grounded. If inadvertently grounded, remove source from ground. Contact with any part of a grounded battery can result in electric shock and burns by high short-circuit current. The likelihood of such shock can be reduced if such grounds are removed during installation and maintenance by a skilled person (applicable to equipment and remote battery supplies not having a grounded supply circuit).

**Failure to follow these instructions will result in death or serious injury.**

7. Remove the batteries from the shelves. Recycle or reuse the batteries as appropriate.

**⚠️⚠️ DANGER**

**HAZARD OF ELECTRIC SHOCK, EXPLOSION, OR ARC FLASH**

Servicing of batteries must only be performed or supervised by qualified personnel knowledgeable of batteries and the required precautions. Keep unqualified personnel away from batteries.

- Recycle lead-acid batteries correctly. Batteries contain lead and dilute sulfuric acid.
- Dispose of the batteries in accordance with country and local regulations.

**Failure to follow these instructions will result in death or serious injury.**

8. Reinstall the terminal cover on the left side of the battery breaker.

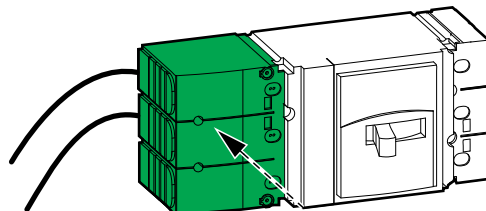

9. Disconnect and remove any signal cables from the classic battery cabinet.

10. Reinstall the breaker protection plates.

**GVSCBC7C, GVSCBC7D, GVSCBC7E**

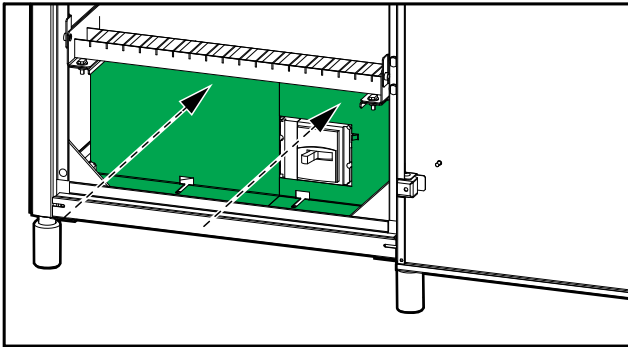

**GVSCBC10A2, GVSCBC10B2**

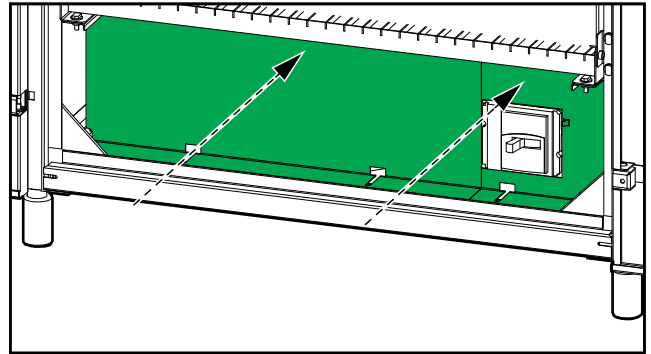

11. Close the door(s). On GVSCBC10A2 and GVSCBC10B2, install two screws to close the left door.

**GVSCBC10A2, GVSCBC10B2**

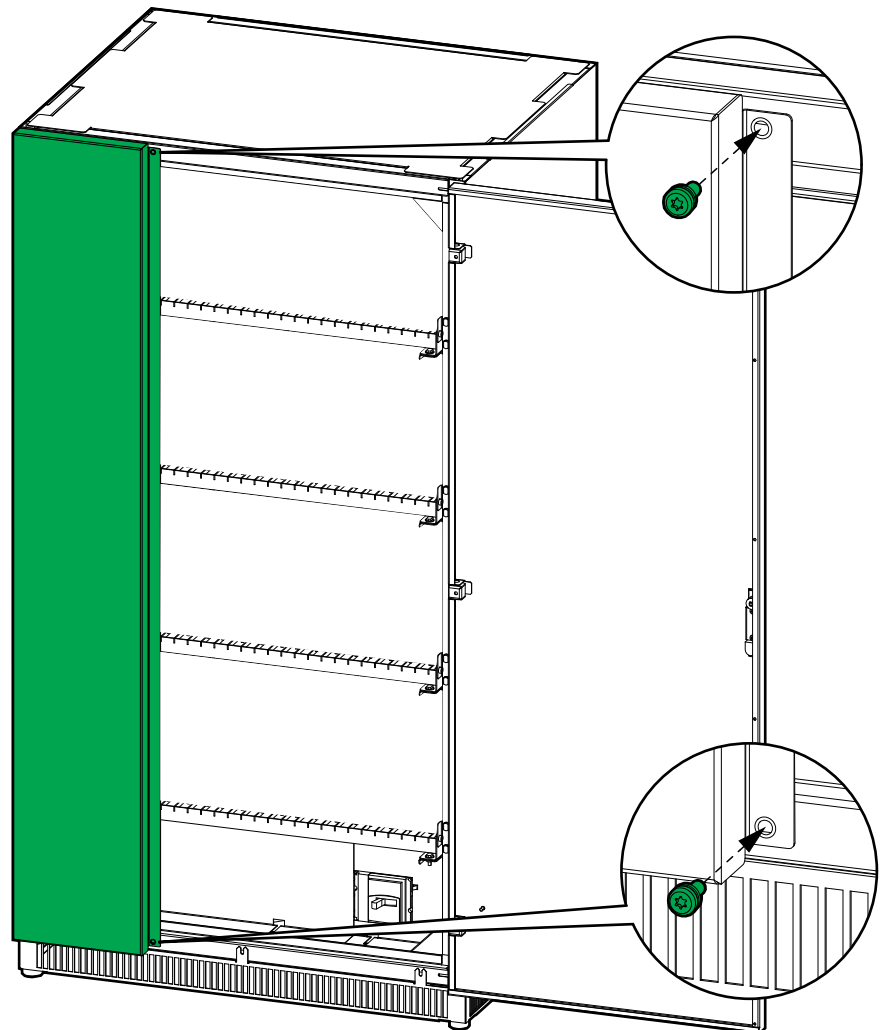

12. Remove the kick plates from the front, rear, and sides of the classic battery cabinet.

13. Lift the classic battery cabinet from the left or right side with a pallet truck.

<b>⚠ WARNING</b>	
<b>TIPPING HAZARD</b>	
<ul style="list-style-type: none"><li>• Do not lift the cabinet with a forklift. Use a pallet truck</li><li>• Do not lift the cabinet from the front or from the rear. Lift from the left or right side.</li></ul>	
<b>Failure to follow these instructions can result in death, serious injury, or equipment damage.</b>	

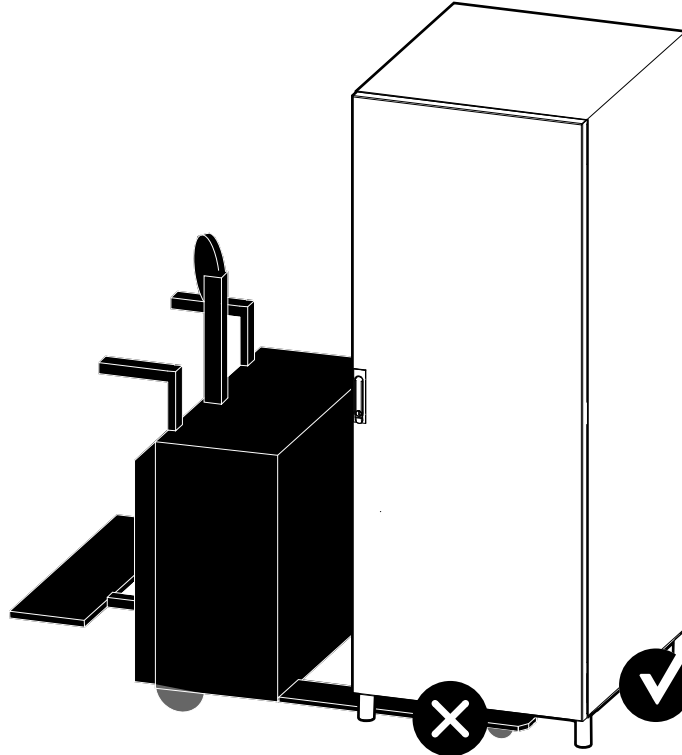

14. Perform one of the following:
- Decommission the classic battery cabinet, OR
  - Move the classic battery cabinet to a new location to install it.
15. **Only for installing the classic battery cabinet in new a location:** Reinstall the batteries in the classic battery cabinet after moving it to the new location. Follow the installation manual to install battery interconnections, signal cables, power cables, etc. See *Installation Procedure*, page 18 for installation overview.



Schneider Electric  
35 rue Joseph Monier  
92500 Rueil Malmaison  
France

+ 33 (0) 1 41 29 70 00



\* 9 9 0 - 5 9 1 3 E - 0 0 1 \*

As standards, specifications, and design change from time to time,  
please ask for confirmation of the information given in this publication.

© 2018 – 2024 Schneider Electric. All rights reserved.

990-5913E-001